

(12) UK Patent Application (19) GB (11) 2 334 890 (13) A

(43) Date of A Publication 08.09.1999

(21) Application No 9904881.1
(22) Date of Filing 03.03.1999
(30) Priority Data
(31) 09040504 (32) 07.03.1998 (33) US
(31) 09165475 (32) 02.10.1998
(31) 09191928 (32) 13.11.1998

(51) INT CL⁶
A61F 2/40
(52) UK CL (Edition Q)
A5R RAD
(56) Documents Cited
EP 0679375 A1 EP 0617934 A1 EP 0339530 A2
WO 98/46172 A1 WO 96/17553 A1 US 4919670 A

(71) Applicant(s)
Randall J Huebner
18650 S W Hart Road, Aloha, Oregon 97007,
United States of America
(72) Inventor(s)
Randall J Huebner
(74) Agent and/or Address for Service
Potts, Kerr & Co
15 Hamilton Square, BIRKENHEAD, Merseyside,
CH41 6BR, United Kingdom

(58) Field of Search
ONLINE: EPODOC, WPI, JAPIO

(54) Abstract Title
SHOULDER PROSTHESIS

(57) A shoulder prosthesis having a head (212) and an elongate stem portion (218) including a proximal end connected to the head, a distal section for insertion into a medullary canal of a humeral bone. The head (212) and stem (218) are connected via a conical taper lock including male and female portions (222, 226) disposed on the stem and head respectively. The portion of the taper lock situated on the stem is offset to provide adjustment for a left or right shoulder prosthesis. An alignment section (not shown) may be disposed between the proximal end and distal section, which includes a plurality of reference marks positioned to facilitate placement of the prosthesis in the bone at a previously determined position.

In an alternative embodiment, the taper lock may comprise a tapered wedge (Fig 1; not shown). A shoulder prosthesis kit is also claimed.

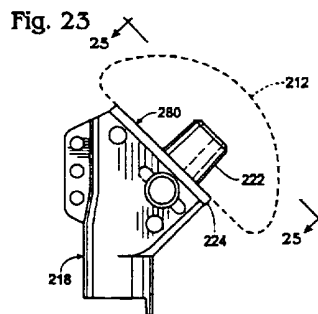
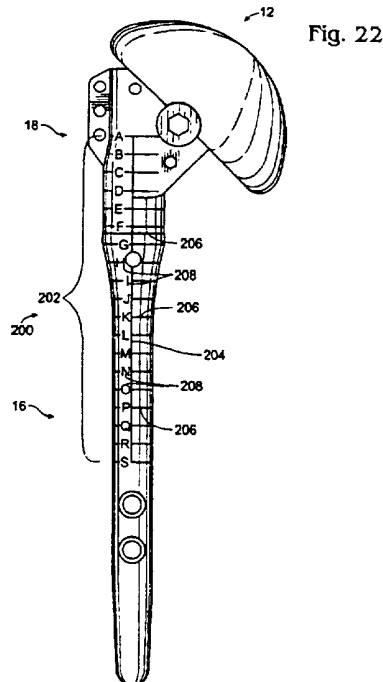

GB 2 334 890 A

Fig. 1

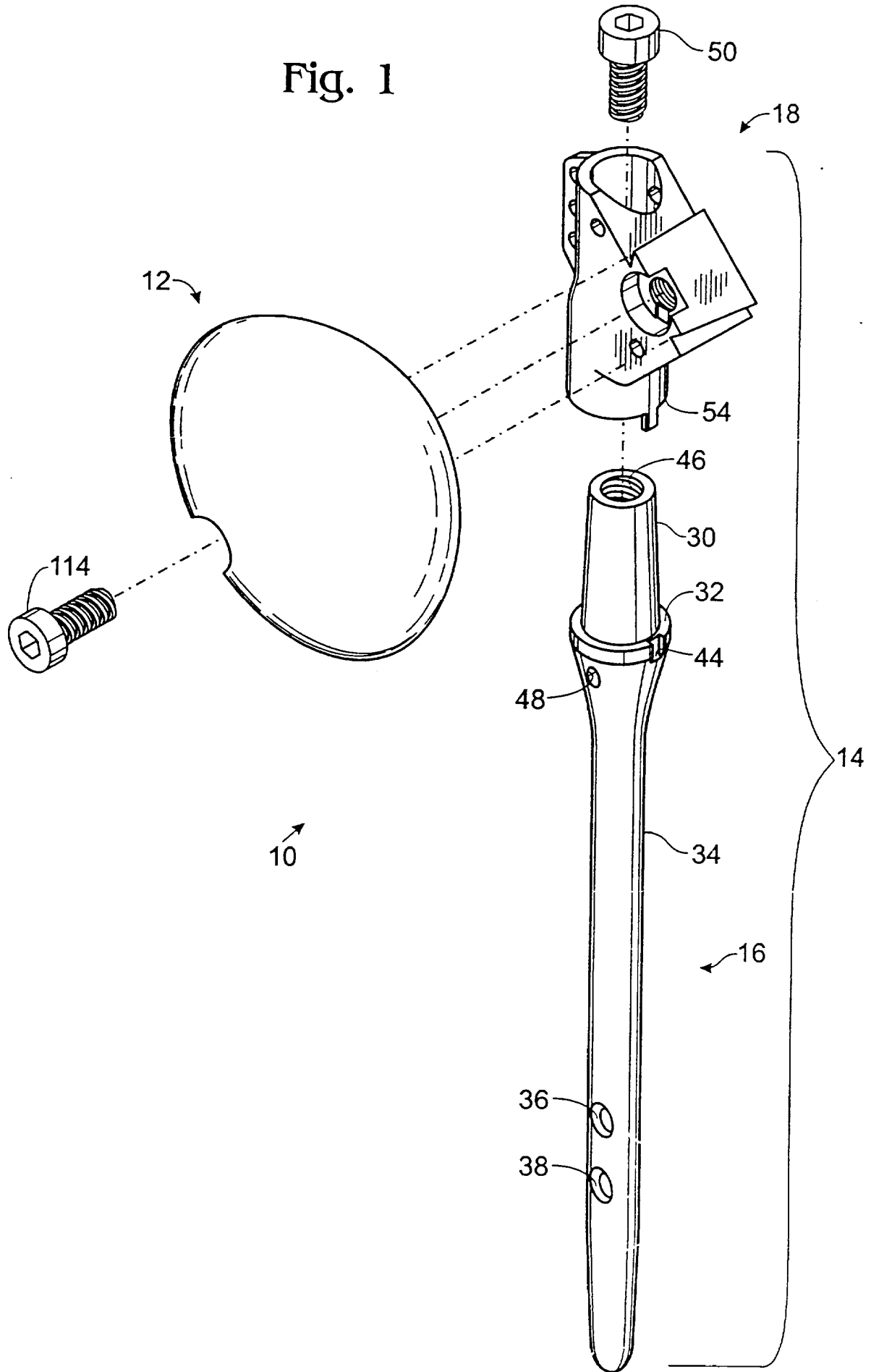

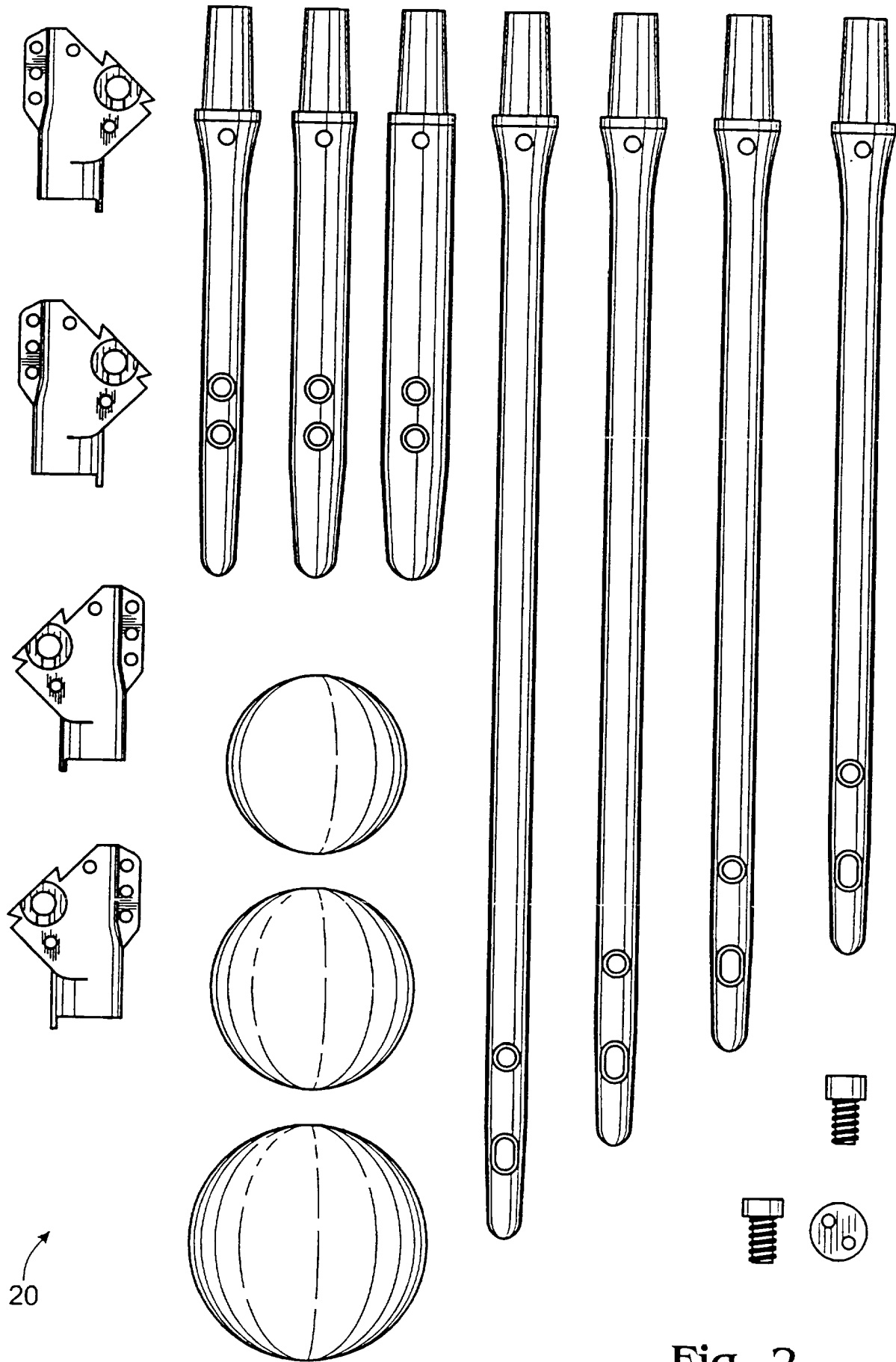

Fig. 2

Fig. 16

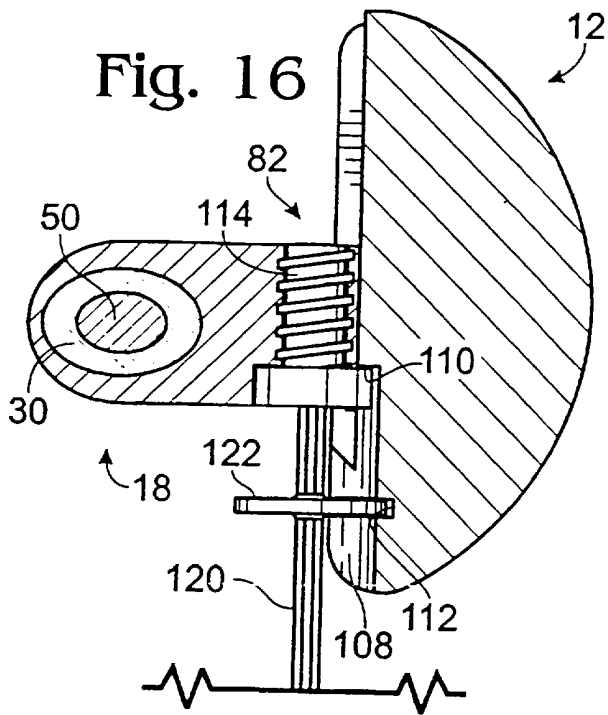

Fig. 3

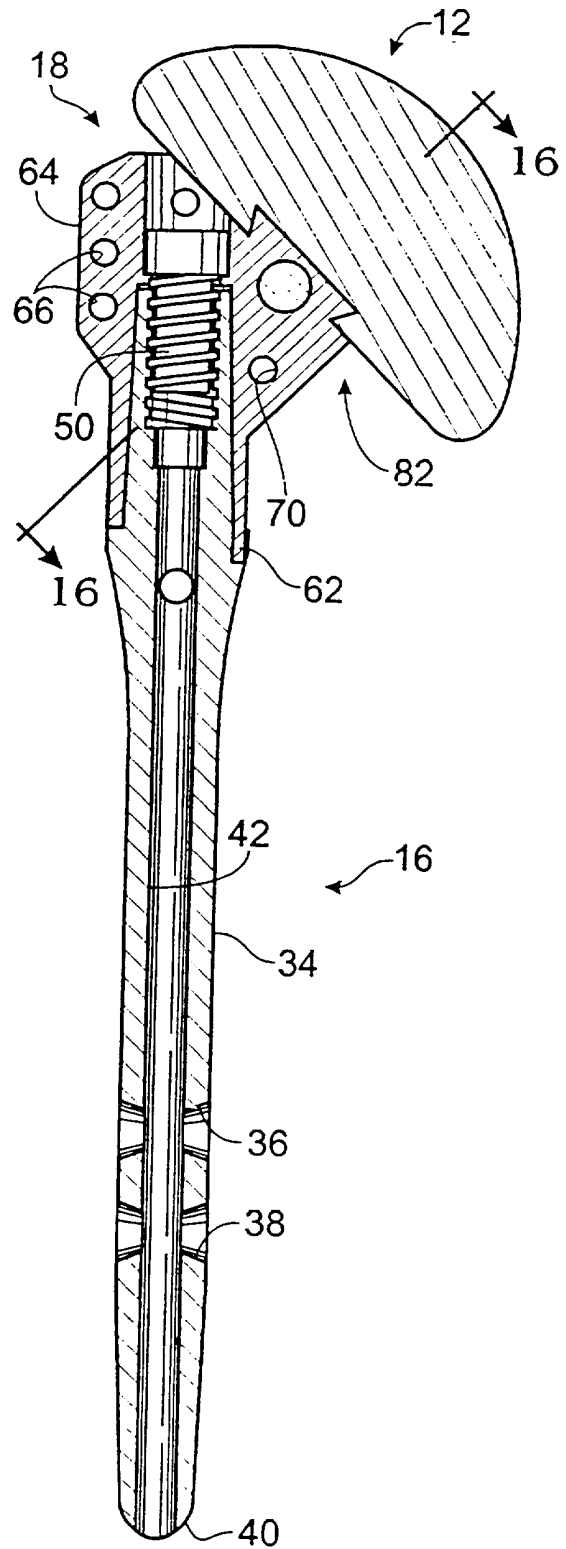

Fig. 15

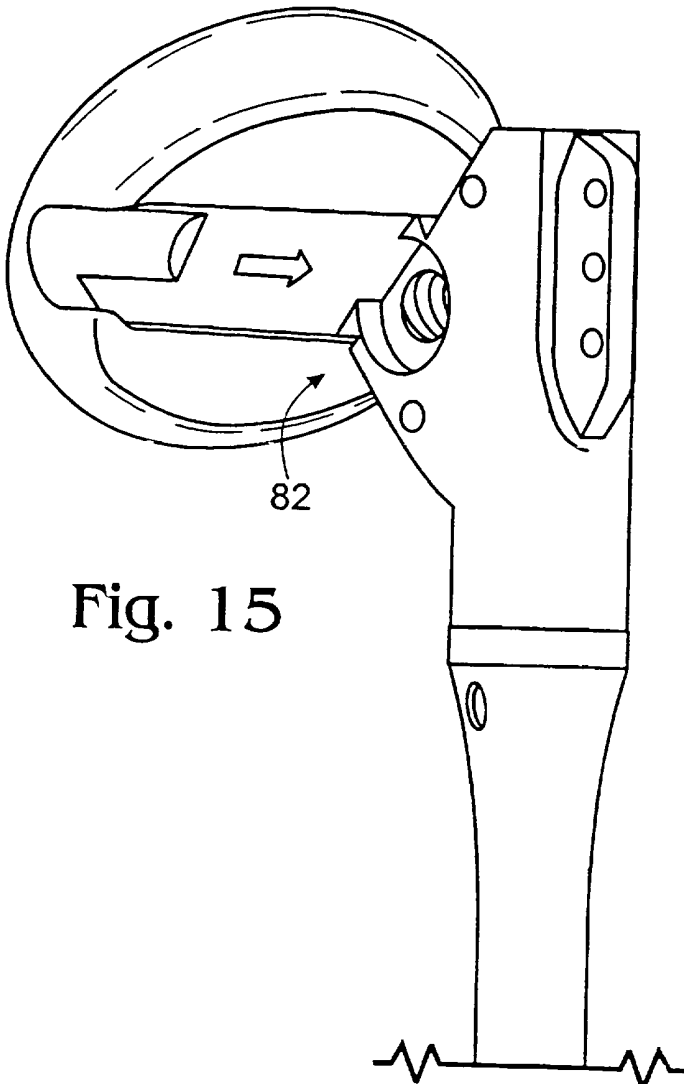

Fig. 4

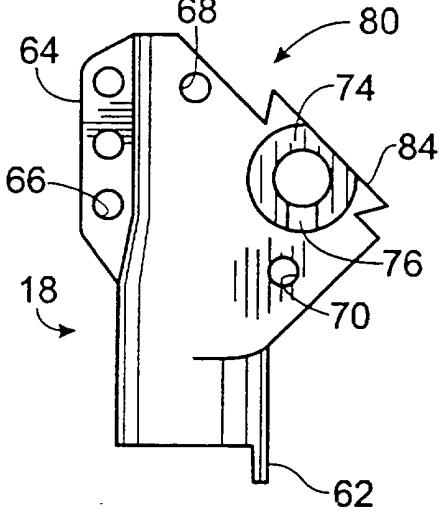

Fig. 5

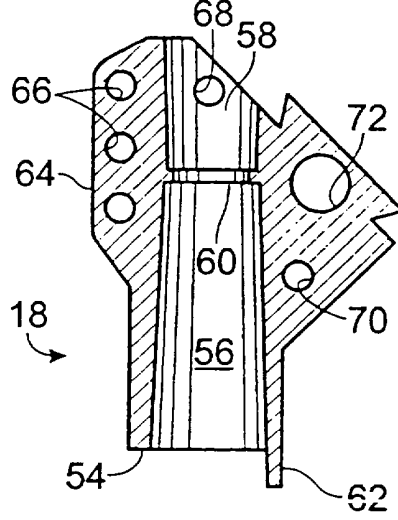

Fig. 6

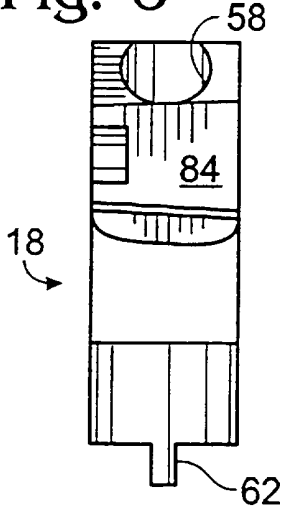

Fig. 7

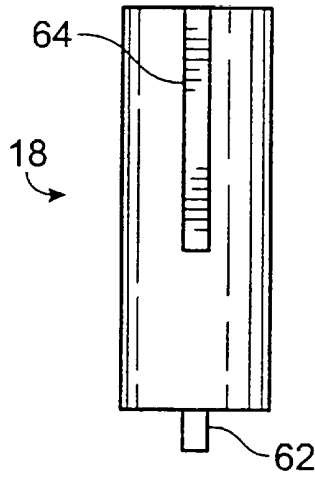

Fig. 8

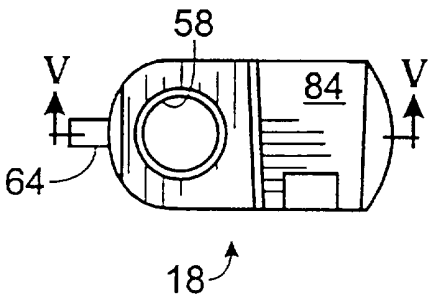

Fig. 9

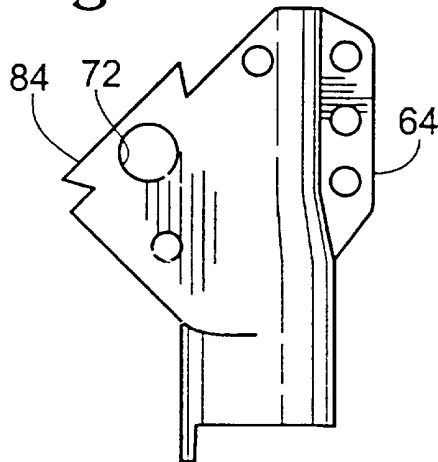

Fig. 10

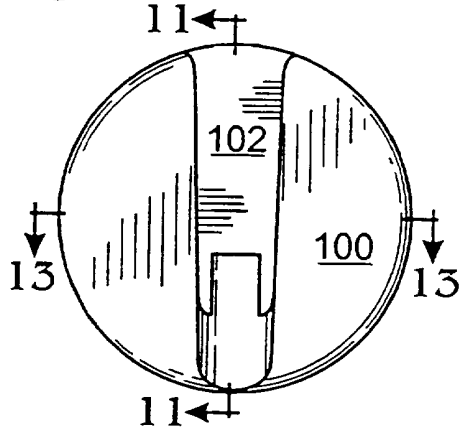

Fig. 11

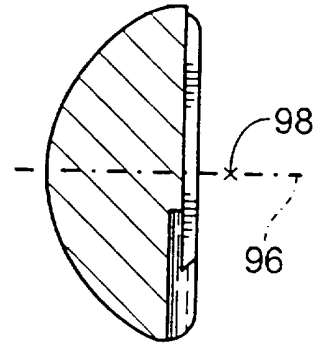

Fig. 12

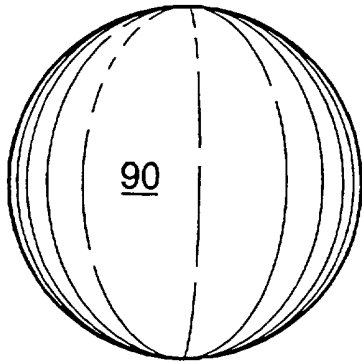

Fig. 13

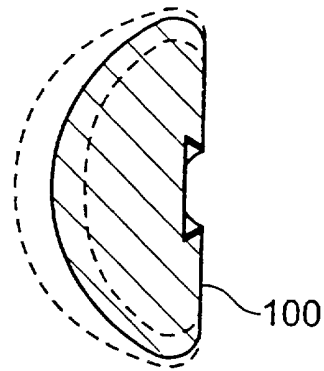

Fig. 14

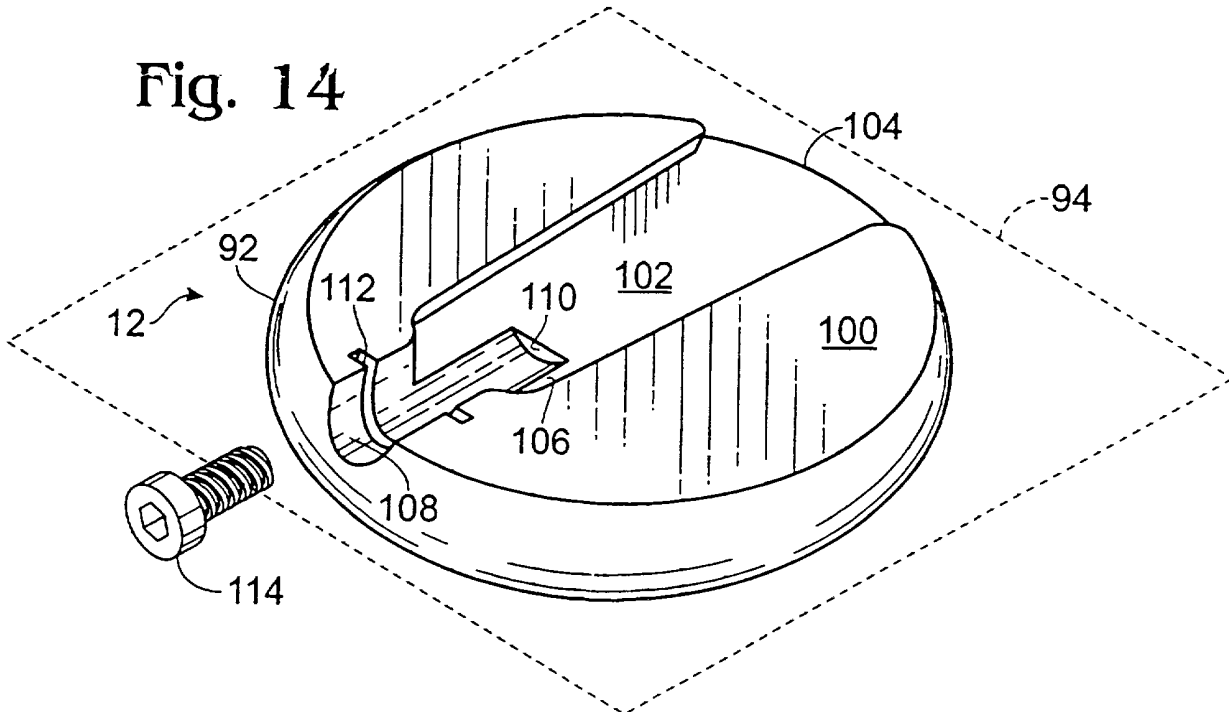

Fig. 18

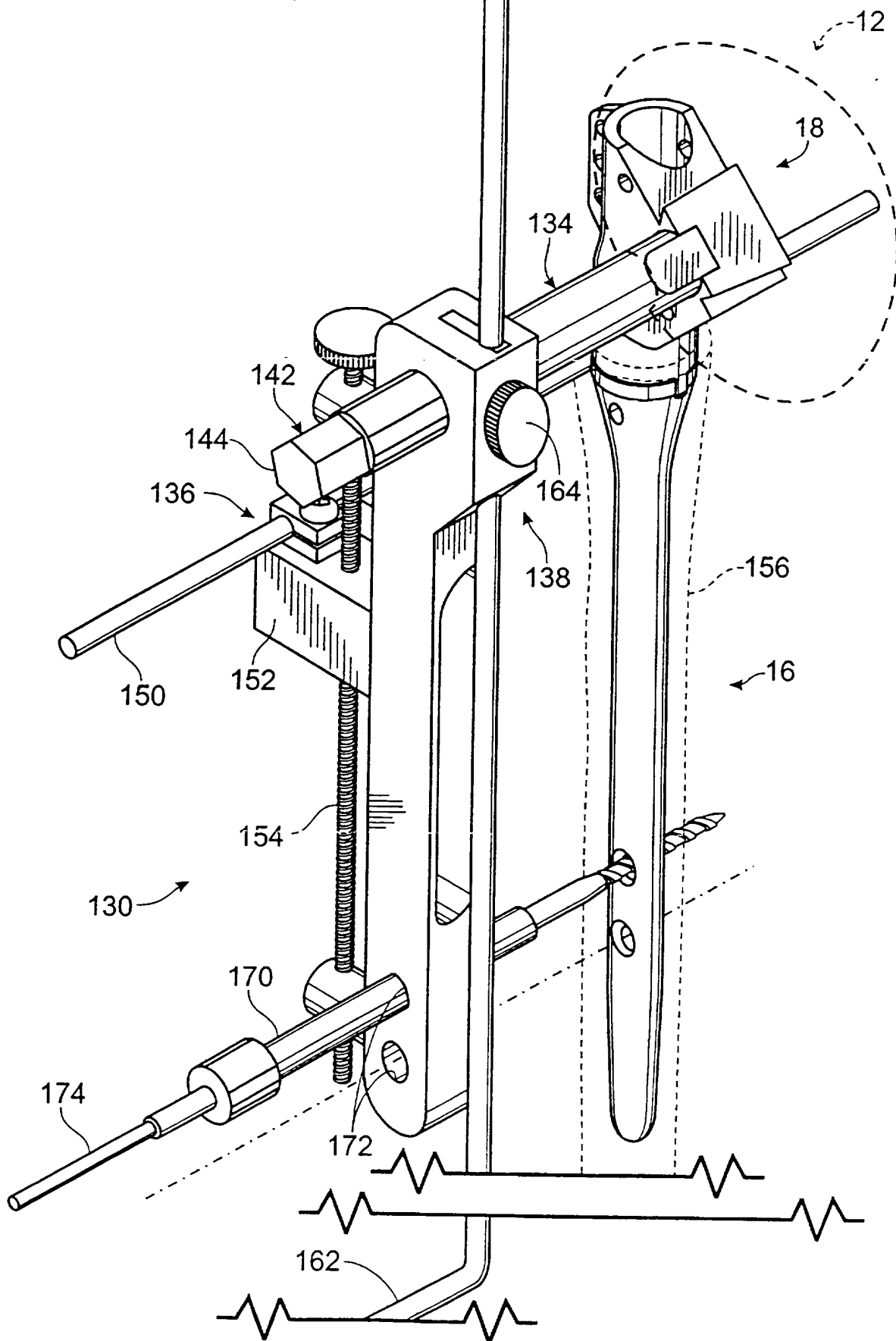

Fig. 19

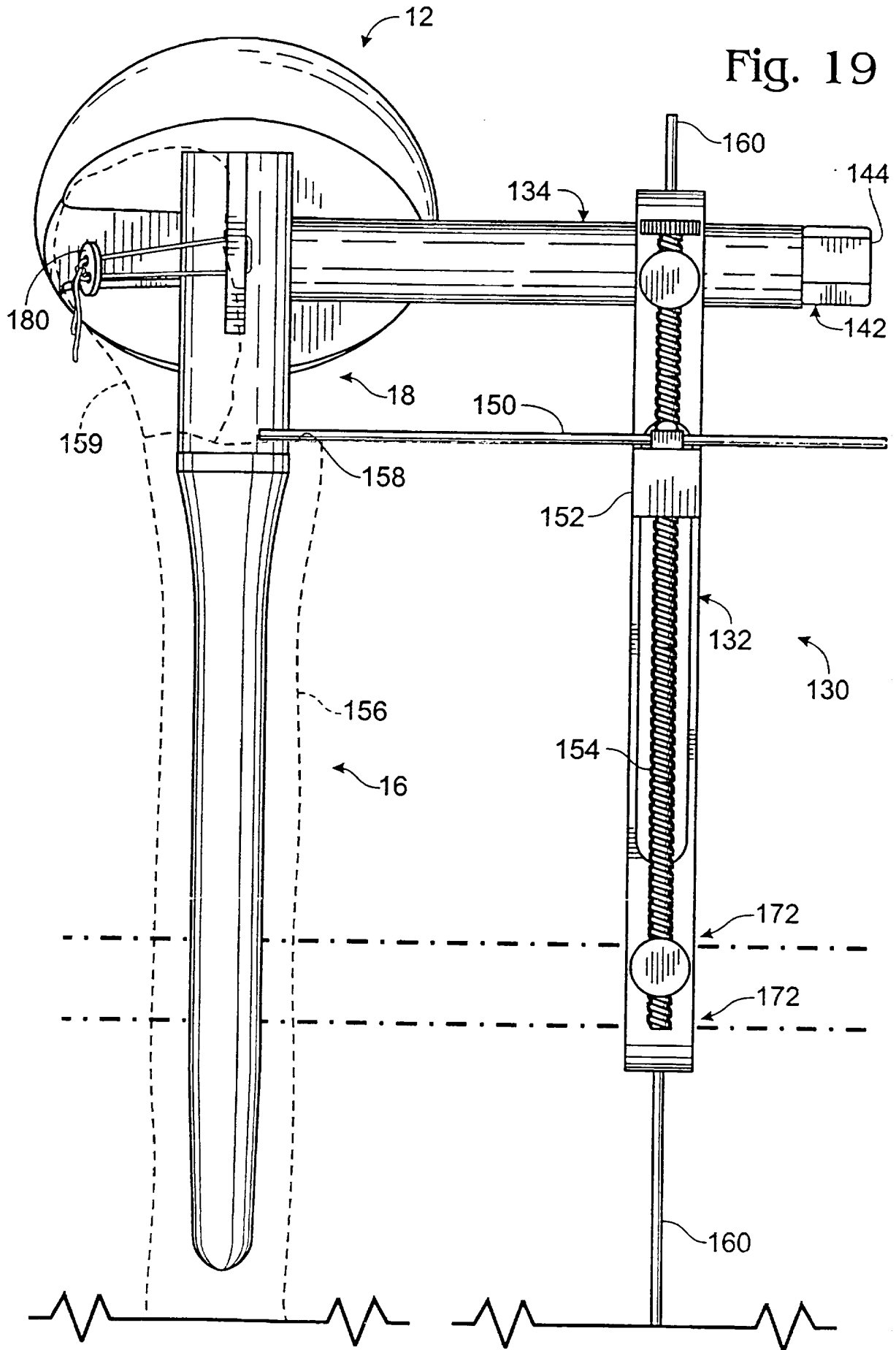

Fig. 20

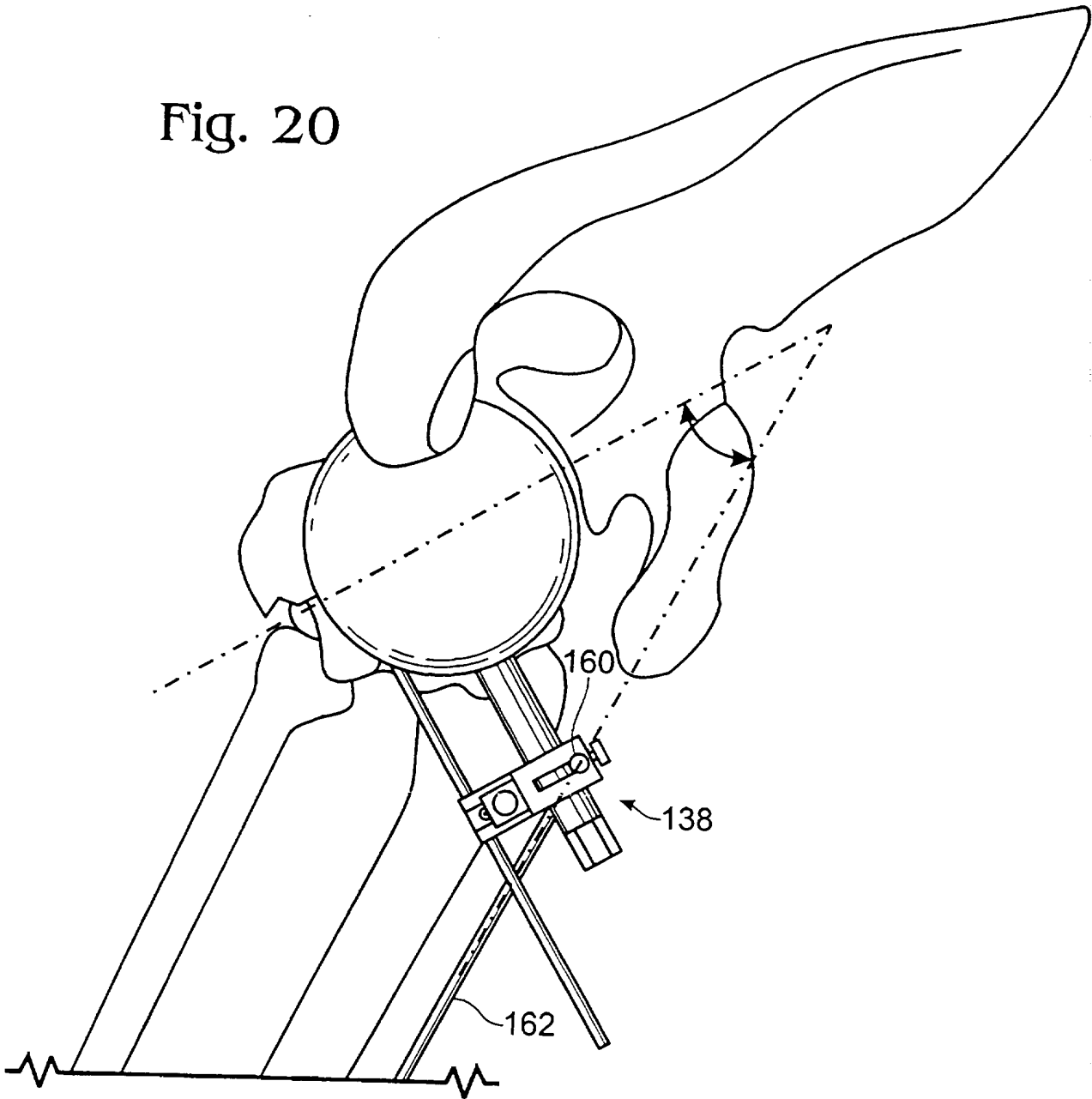

Fig. 21

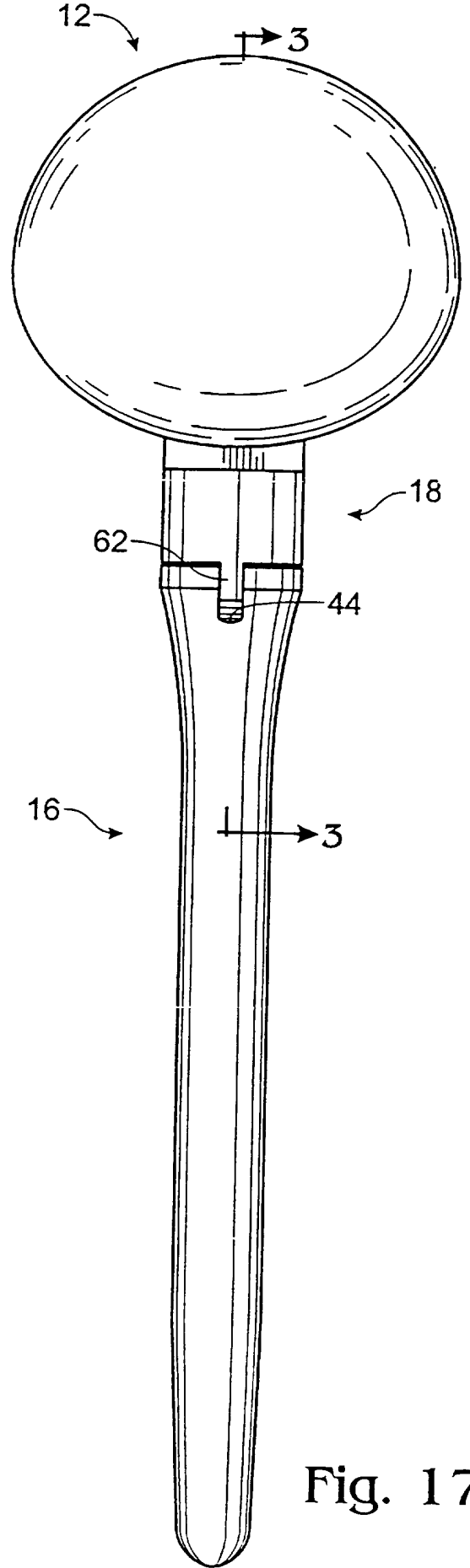
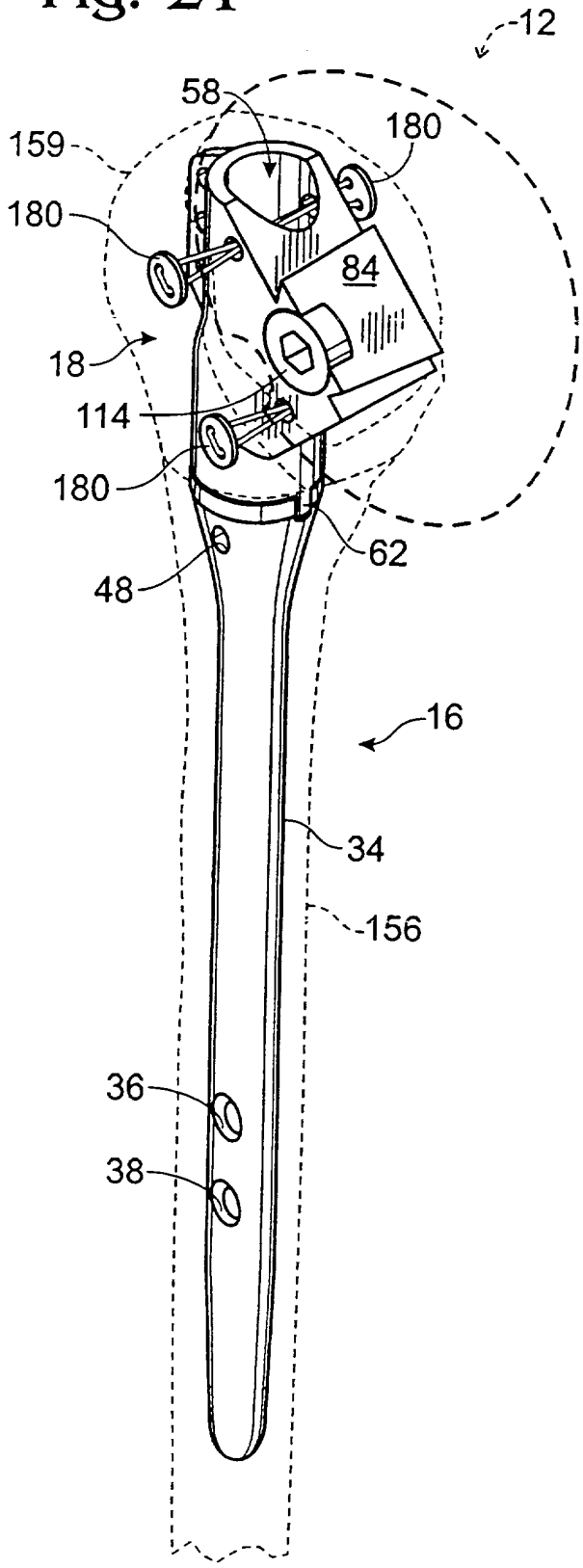

Fig. 17

Fig. 22

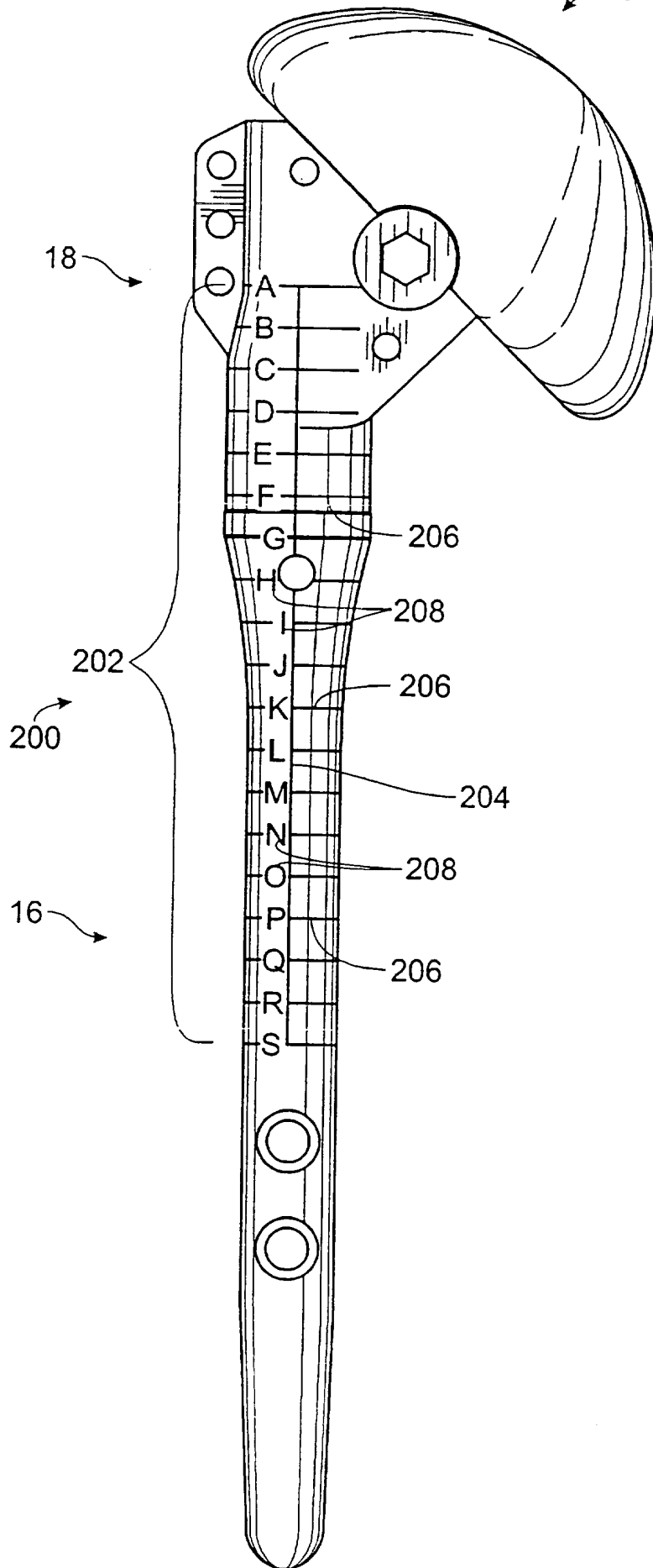

Fig. 23

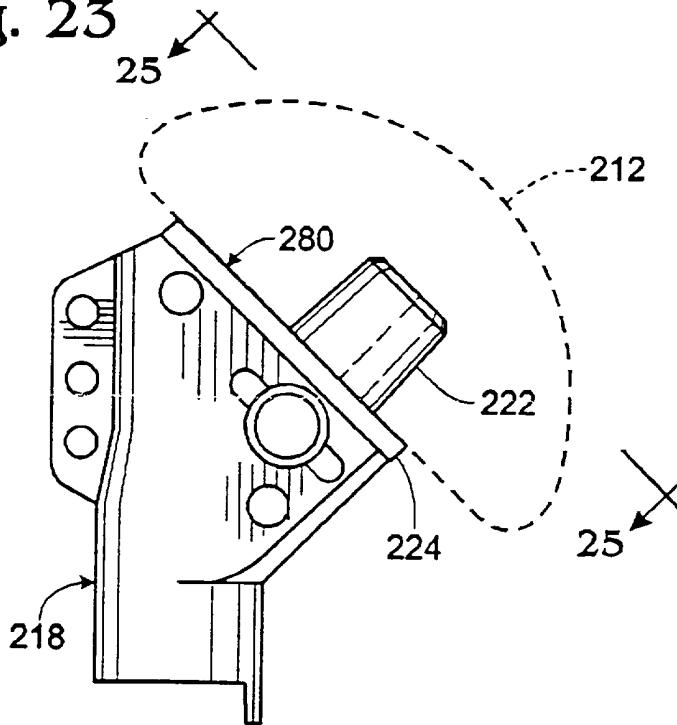

Fig. 24

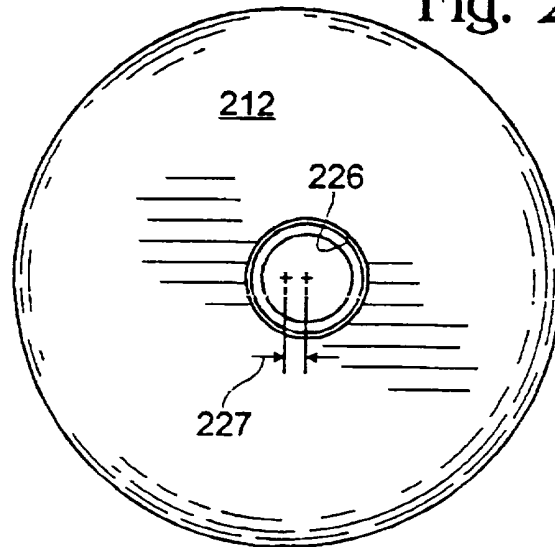
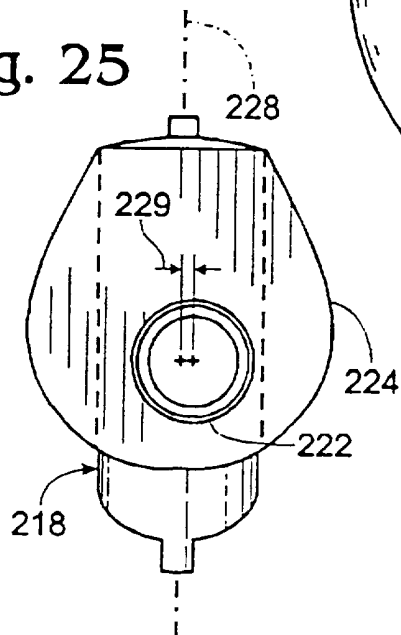

Fig. 25



SHOULDER PROSTHESIS

This invention relates generally to bone prostheses and more particularly to a shoulder prosthesis.

Cross-Reference to Related Applications

5 This application is a continuation-in-part of U.S. Patent Application Serial No. 09/040,504, filed March 17, 1998 and U.S. Patent Application Serial No. 09/165,475, filed October 2, 1998.

Background of the Invention

When a joint, such as the hip or shoulder, becomes impaired due to
10 arthritis, disease or trauma, it is sometimes necessary to replace all or part of the joint with a prosthesis to restore function. For instance, hip replacement, where a prosthesis is provided to replace the femoral head and in some cases all or part of the acetabulum, has become a common procedure to treat femoral head fractures and arthritis in elderly patients. As a result of anatomical constraints and challenges in the shoulder, shoulder
15 implants have historically been much less successful and less common than hip replacements. Recently, however, shoulder arthroplasty has emerged as an accepted treatment for severe arthritis and humeral head fractures.

As a consequence of the increasing acceptance of shoulder prostheses, many different devices have been developed to address various problems that have arisen
20 and to offer additional benefits and features. In the simplest form, a shoulder prosthesis is formed as a single piece with a head to articulate with the glenoid cavity, and a stem to

extend down the medullary canal of the humerus and support the head. While simple to construct, unitary implants do not offer any adjustability to accommodate the natural variations in size and geometry that occur among joints of different patients. To accommodate these variations, a large stock of devices must be manufactured and maintained to insure that an adequate match can be achieved during an operation. Stocking the large number of devices is a significant expense with one-piece designs, and in some cases a surgeon may not be provided with sufficient flexibility to achieve an ideal fit to the patient.

To avoid the expense of maintaining a large stock of single-piece prosthetics and to provide increased flexibility to surgeons, many shoulder implant makers have gone to a modular design that is assembled during the operation from two or three pieces. These pieces include a head to articulate with the glenoid and a stem structure on which the head is mounted and secured to the bone. In some cases, the stem includes a separate body portion disposed between the head and an intermedullary portion of the stem that extends down the medullary canal. By utilizing a modular design, a wide variety of devices can be assembled from only a few pieces, thus providing increased flexibility to accommodate anatomical variation and eliminating much of the cost associated with maintaining a large selection of one-piece devices.

Existing modular shoulder designs most commonly rely on a taper lock mechanism to secure the head to the rest of the implant. In at least some devices the portion of the taper lock on the head is offset to compensate for anatomical posterior

offset of the humeral head. For instance, the taper lock portion on the head may be offset by 2-4 millimeters. By rotating the head, any offset between plus and minus the 2-4 millimeters can be achieved. Unfortunately, rotating an offset head can introduce a medial/lateral and/or superior/inferior offset at the same time the anterior/posterior positioning is adjusted. Furthermore, the offset between the center of the taper lock and the geometrical center of the head creates a torque which tends to rotate the head relative to the remainder of the implant, thereby increasing the chance of loosening of the head. As the offset increases, the resultant torque increases as well, making this a greater problem for larger offsets. Although such problems are incumbent in existing offset head designs, a posterior offset is generally desirable to better match the natural anatomy.

In addition to the specific drawbacks associated with various existing implant designs, there are a number of general problems inherent in shoulder replacements. In particular, it is generally difficult to establish the proper position and orientation for the implant in the humerus. One of the more important variables is the rotational position, or retroversion, of the head on the humerus. Anatomically, the average retroversion between a plane defined by the perimeter of the anatomical head and the axis of the flexed forearm is approximately 30-degrees. Unfortunately, with existing implants and techniques for their installation, it has been very difficult to reliably reproduce desired retroversion. Establishing correct retroversion is important because incorrect retroversion can lead to problems with subsequent dislocation.

In addition to the retroversion of the implant, it is necessary to establish the correct height of the implant on the humeral shaft. With existing designs, the surgeon slips the stem into the medullary canal and makes an educated guess at the proper height. Excess height may create too much tension in the deltoid, while inserting the implant too far down the humerus can result in deltoid lag. Similarly, the offset of the face of the head relative to the stem must be established correctly or excess or insufficient tension in the rotator cuff may be created. Unfortunately, with existing designs there is no way to evaluate implant height or head offset prior to final installation, after which correction is difficult.

10

Summary of the Invention

The present invention is a shoulder prosthesis having a head and an elongate stem portion including a proximal end connected to the head, a distal section for insertion into a medullary canal of a humeral bone and an alignment section disposed between the proximal end and distal section. The alignment section includes a plurality of reference marks positioned to facilitate placement of the prosthesis in the bone at a previously determined position.

15

Brief Description of the Figures

Fig. 1 is an exploded isometric view of a modular shoulder implant constructed according to the present invention.

20

Fig. 2 shows a modular shoulder implant kit constructed according to the present invention.

Fig. 3 is a cross-sectional view of a shaft of the implant of Fig. 1.

Figs. 4-9 are various views of a body portion of the implant of Fig. 1.

Figs. 10-13 are various views of a head portion of the implant of Fig. 1.

Fig. 14 is an isometric view of the backside of the head of Figs. 10-13.

5 Fig. 15 is an isometric view of the head partially installed on the body.

Fig. 16 is a cross-sectional view of the implant along line 8-8 of Fig. 3.

Fig. 17 is a medial elevational view of the implant of Fig. 1.

Fig. 18 is an isometric view of a targeting/installation instrument according to the present invention.

10 Fig. 19 is a lateral elevational view of the targeting/installation instrument of Fig. 10.

Fig. 20 is an elevational view from above of the targeting installation instrument of Fig. 18.

Fig. 21 is an isometric view of the implant of Fig. 1 in an assembled
15 configuration.

Fig. 22 is a side elevational view of an implant showing reference marks.

Fig. 23 is a side elevational view of a body constructed according to the present invention.

Fig. 24 is an elevational view of the rear surface of a head constructed
20 according to the present invention.

Fig. 25 is an elevational view along line 25-25 in Fig. 23.

Detailed Description

A shoulder implant constructed according to the present invention is shown generally at 10 in Fig. 1. Implant 10 includes a head 12 and a stem 14. The stem preferably includes a distal shaft 16 and a body 18. The components making up implant 10 are preferably chosen from a kit 20 of interchangeable shafts, bodies and heads, as shown in Fig. 2. By selecting an appropriate shaft, body and head from kit 20, a surgeon is able to create an implant that is sized properly for almost any patient. It should be noted that positional references such as anterior/posterior, medial/lateral and proximal/distal used herein are made with reference to an implant as it would be positioned in a patient.

Shaft 16 is shown in greater detail in Fig. 3 and includes a proximal tapered end 30 extending distally to a shoulder 32 which tapers smoothly into a cylindrical medial region 34 with distal locking holes 36, 38. As can be seen in Fig. 2, the shaft can have a medial region of varying diameter and/or varying length. Generally speaking, the longer shafts are used where there is a mid-shaft fracture in addition to the proximal trauma. The varying diameter short shafts are used to accommodate size variations in the proximal end of the humerus. Either or both of holes 36, 38 may be elongated to allow for movement of the medial region over the locking screws. This is normally desirable when the implant is used to treat a combined mid-shaft fracture.

A rounded and tapered distal tip 40 is formed on the end of medial region 34. Shaft 16 preferably includes a central canulation 42 which can be used to guide the

implant into the humerus with the aid of a guide wire. As best shown in Fig. 1, an alignment notch 44 is formed in shoulder 32 to aid in establishing the correct orientation of the body on the shaft, as will be described below. A threaded hole 46 is formed in tapered end 30 to receive a screw 50 which is used to draw the body firmly onto the tapered end. A wiring hole 48 is provided just distal of shoulder 32 to allow tension band wiring to be secured through the implant. In addition, when the implant is to be cemented in place, a K-wire can be driven through humerus and hole 48 to fix the position of the implant while the cement cures.

As indicated in Fig. 1, body 18 mounts to the top of shaft 16. Referring to Figs. 4-9, body 18 has a distal end 54 with a cylindrical tapering socket 56 extending upwardly therefrom into the body. Socket 56 is sized to receive tapered end 30 of shaft 16 and taper-lock thereto to allow the body to be securely mounted to the shaft. A proximal bore 58 extends from the socket to the top of the body to the previously discussed screw to engage the top of the shaft to draw it into the socket. A small rib 60 is provided in the bore to engage against the head of the screw.

A small finger 62 projects down from the distal end of body 18 adjacent the socket to engage alignment notch 44 as the body is installed on the shaft. See Figs. 1 and 17. This ensures the proper rotational positioning of the body on the shaft so that the various holes in the shaft are oriented correctly. Body 18 further includes a lateral rib 64 with three suture holes 66 which aid in securing the fracture fragments to the implant. Upper and lower medial suture holes 68, 70 are also provided in body 18 to offer

additional options in securing the fragments. A medially-positioned, anteriorly-oriented threaded hole 72 is formed in body 18 to receive a screw for securing the head to the body. Hole 72 also serves as a mounting point for a targeting/installation instrument used with the implant. A recess 74 is located at the top of the hole and includes a keying notch 5 76 for orienting the targeting/installation instrument. See Figs. 1 and 4. The recess allows the screw head to install substantially flush with the surface of the body to minimize the amount of bone removal required to insert the stem into the humerus.

Body 18 includes a medially-facing inclined mounting surface 80 at the proximal end onto which head 12 is mounted. Head 12 is secured to body 18 by coupling 10 structure 82 which includes a fitting in the form of a pedestal or dovetail 84 located on mounting surface 80. As shown in Figs. 6 and 8, dovetail 84 is tapered from anterior to posterior to establish a taperlock with the head, as will be described below. Because the dovetail is tapered, the body has a left or right orientation depending on which shoulder is to be replaced. Thus, as shown in Fig. 2, the kit will preferably include two or more 15 bodies. Additional bodies, over and above one left and one right, may be provided to accommodate different stem diameters or head angles, etc.

Head 12, which is preferably formed as a unitary member, as opposed to being assembled from two or more components, includes a generally semi-spherical articulation surface 90 which is adapted to engage the glenoid cavity in the shoulder. See 20 Figs. 10-13. Because the glenoid cavity does not define a close fitting socket, such as

found in the acetabulum in the hip joint, the articulation surface only needs to be sufficiently spherical to allow smooth articulation in the glenoid cavity.

As best shown in Fig. 14, articulation surface 90 is bounded by an articular margin 92 which defines an articular plane 94 generally normal to a head axis 96. In the preferred embodiment, where the head is substantially spherical, the head axis represents a central axis of rotational symmetry for the articulation surface and a center of curvature 98 lies on the head axis. See Fig. 11. As shown by the dotted lines in Fig. 13, the various heads are preferably formed with the same radius, but simply represent larger portions of a sphere. It is believed that this best reflects the actual anatomical characteristics.

In the most commonly occurring fracture pattern, the anatomic head fractures generally through the articular margin and plane. The articular plane defines generally the distal extent of head 12. This is important when it is necessary to remove the head as part of a revision procedure, because the present invention allows the head to be removed from an anterior direction without dislocation of the joint and the associated trauma. This is not the case with existing implant heads, which cannot be separated from the body for removal without first dislocating the joint. It is desirable, although not required, that the head not project substantially beyond the articular plane in the present invention so that it is possible to slide the head out of the joint in an anterior direction without disruption of the surrounding bone. Because the remainder of the humerus is distal to the articulation plane, the head may be slid out in that plane without disruption of the surrounding bone as long as the head does not project substantially beyond the

articular plane. Thus, the coupling structure is adapted to allow the head to be installed on and removed from the stem without dislocating the shoulder after the implant has been installed in the shoulder.

Head 12 includes a mounting surface or backside 100 disposed opposite the articulation surface and separated from the articulation surface by the articular margin. Backside 100 includes a portion of coupling structure 82 in the form of a transverse track or undercut channel 102. Channel 102 is cut to match the cross-sectional shape and taper of dovetail 84 and includes an open end 104 and an inner end 106. A cylindrical recess 108 extends from the perimeter of the head past the inner end of the channel and to a stop 110. A groove 112 is formed in recess 108 near the edge of the head.

The channel is sized so that the head is guided onto the body and the dovetail taperlocks in the channel when the head is properly positioned. See Fig. 10. The taperlock connection is important because it rigidly secures the components and prevents them from fretting against each other and generating debris over time. The coupling structure of the present invention may also be described as a transversely acting taper lock, with a portion of the taper lock being disposed on the head and a portion disposed on the body. The taper lock of the present invention is transverse acting in that it does not rely on motion along the axis of the head to lock, contrary to existing designs. In fact, it can be seen that, when the head is engaged on the stem, the coupling structure mechanically interlocks the head against motion transverse to the articular plane. This is

in contrast to existing designs, which simply rely on a frictional interconnection in the direction transverse to the articular plane.

A locking member in the form of a screw 114 is provided to draw the head firmly onto the body to properly seat the taperlock. In particular, after head 12 is initially positioned on the body, as shown in Fig. 15, it is slid generally into position and screw 114 is installed into hole 72 with the head of the screw fitting closely into cylindrical recess 108. See Fig. 16. As the screw is driven in, the head of the screw engages stop 110 to pull head 12 firmly onto body 18. Screw 114 also serves as a backup interlock to insure that the head does not become dislodged. It should be noted that the head of the screw will not seat completely against the body because some space must be left to accommodate machining tolerances in the coupling structure so that the taper lock may be drawn tight in all cases.

When it is necessary to remove the head, as in a revision, a tool 120 with a flange 122 secured near the tip of the tool is utilized. See Fig. 16. The tip of the tool is initially installed in the screw head from a slight angle away from the head and then the tool is rotated toward the head to engage the flange with taper breaking surface in the form of a groove 112 formed in recess 108. As the screw is backed out, the flange pulls against the head to dislodge the taperlock. Thus, the head can be removed with application of external force to the implant, as has been required with prior designs. This reduces the chance that the entire implant will be loosened when only the head needs to be removed.

Installation of the implant of the present invention is facilitated by a targeting/installation instrument, shown generally at 130 in Fig. 18. Instrument 130 includes a template member 132 to which are mounted a mounting bar 134, a height adjusting mechanism 136 and a retroversion guide 138. Mounting bar 134 serves to join
5 template member 132 to implant 10. In particular, bar 134 is hollow and includes a tab 140 (not shown) at the free end. The bar receives a bolt 142 with a head 144 and a threaded end 146. To attach the instrument to the implant, the free end of the bar is placed in recess 74 and aligned so that tab 140 fits into keying notch 76. This establishes the correct alignment between the template and the implant. The threaded end of the bolt
10 is then screwed into hole 72 to secure the instrument to the implant. The bar includes a flat 148 to allow the bar to reach body 18 without engaging head 12. In addition, it should be noted that the screw which secures the head to the body is not installed until after the instrument is removed.

Once the instrument is mounted to the implant, the stem is inserted into the
15 shaft of the humerus. In the typical fracture pattern, the head and greater and lesser tubercles are separated from the remainder of the humerus, leaving a pipe-like upper shaft. As a result, there is no remaining reference for the correct height of the implant head relative to the top of the humeral shaft. It is important to position the head at the correct height relative to the humeral shaft to avoid excess tension on the deltoid muscle
20 by having the head too high or deltoid lag where the head is too low and the deltoid must undergo some contraction prior to starting to move the arm.

The height adjusting mechanism allows the surgeon to temporarily set the height of the head and then evaluate the deltoid tension. In particular, as shown in Figs. 18 and 19, height adjusting mechanism 136 includes a guide bar 150 which is moveably mounted to a carriage 152, which is driven up and down along a threaded rod 154. With the implant in a humeral shaft 156, the guide bar is positioned to sit on top 158 of the humeral shaft. The surgeon can then adjust the implant up or down by turning the threaded rod. The guide bar establishes a predetermined height, which can be maintained while retroversion is set and even if the implant is removed and reinserted, as when bone cement is used.

After establishing the correct height the surgeon can use the retroversion guide to set correct retroversion, as shown in Fig. 20. The retroversion guide includes an L-shaped rod 160 with a lower sighting arm 162. Rod 160 is pivotally and slidably mounted to template 132 to allow the height and angular orientation of the sighting arm to be adjusted. A set screw 164 allows the position of the rod to be fixed once it is in the desired orientation. In use, the sighting arm is set for a predetermined retroversion angle relative to the head axis, for instance 30-degrees. This can be accomplished before attachment to the implant using a protractor jig (not shown). With the sighting arm set to the correct orientation, the patient's forearm is flexed to approximately 90-degrees to the humerus. The surgeon then rotates the implant to align the sight arm with the axis of the forearm, thereby easily and accurately establishing the desired retroversion.

Once the correct height and retroversion is established, a cannulated drill guide 170 is inserted through guide holes 172 provided in the distal end of the template member. See Fig. 18. Guide holes 172 are oriented to target locking holes 36 in the end of the stem. A drill 174 is inserted through the drill guide to bore through the bone over the locking holes. One or two screws are installed through the humerus and locking holes to secure the implant in place.

As shown by the dotted lines in Fig. 19, it is possible to attach the greater tubercle 159 to the implant prior to final securing of the head. This allows the surgeon to evaluate the tension in the rotator cuff and make corrections, if necessary, by moving to a smaller or larger head. One other feature of the present invention is the provision of suture supports 180, shown in Fig. 21, which serve to distribute the force of the suture over the bone. Particularly in trauma cases, the bone is very soft and without supports 180, the sutures will sometimes pull through the bone. By utilizing the supports, the surgeon can obtain the desired suture tension without risk of the suture pulling through the surface of the bone.

It should be noted that the targeting/installation instrument is provided in left and right versions, although it would also be possible to make mounting bar 134 reversible or symmetric to accommodate left and right bodies. In addition, a longer template member would be used with the longer shafts used to treat mid-shaft fractures.

Installation and alignment of the implant can also be facilitated by placing indications or reference marks on the implant as shown at 200 in Fig. 22. Reference

marks 200 are placed in an alignment section 202 of the stem, generally in the area of the stem which will lie adjacent the top of the humeral shaft when installed. Preferably, the reference marks include one or more angular marks such as angular indication 204 and multiple vertically-spaced gradations 206, allowing both height and angular orientation to be monitored. A plurality of indicia such as letters 208 are applied to the vertically-spaced gradations marks at intervals to make identifying a particular gradation easier. The marks can be laser marked on the surface of the implant, etched into the implant or applied via any other standard marking process. It should be noted that the marks and indicia would normally be viewed from the anterior direction and are therefore preferably placed on that side. In the case of implants that can be placed on either the left or right side, the marks and indicia would preferably be formed on both sides of the implant so that they were visible in either case.

In use, the surgeon first installs one or more trial prostheses to obtain proper fit and positioning in the fashion described above. The trial prostheses are typically identical to the actual prosthesis, but are assembled from a kit of components that are reused from operation to operation. The trial prostheses are equipped with reference marks at the same locations as the actual prosthesis. Once the correct fit and positioning are established, the surgeon notes which gradation is positioned adjacent to the top of the humeral shaft. The surgeon then marks the bone with a methylene blue dye marker at the top of the shaft in line with the angular indication. The surgeon can then take the actual implant and place it in the bone and replicate the trial position, which

)
includes an angular orientation and a depth component, by aligning the previously-noted marks on the actual implant with the previously-determined location on the bone.

It should be understood that the alignment marks could be implemented on a modular or unitary implant and could be used alone or in conjunction with the above-described targeting instrument. Moreover, such marks are beneficial, even when used
5 without a trial device, to verify that an implant has not moved after the desired position has been established.

Another embodiment of a body for use with a shoulder implant according to the present invention is shown at 218 in Fig. 23. Body 218 is similar in construction to
10 body 18, but includes a tapered stud 222 formed on an upper mounting surface 280. A head 212 is adapted to be mounted to body 218 by mounting on stud 222. More specifically, the head includes a tapered bore 226 which fits over stud 222 and is sized to form a taper lock therewith, thus securing the head to the body. A collar 224 forms the lower boundary of mounting surface 280. See Fig. 24. The collar serves to prevent the
15 body from subsiding down into the humerus and creating an outward pressure on the head tending to loosen the taper lock.

As best seen in Fig 25, the axis of the tapered stud is offset from an anterior/posterior plane 228 of the body and stem. In the disclosed embodiment, the offset, indicated at 229, is approximately two millimeters in the posterior direction, as
20 implanted. Generally, suitable offset could be between approximately 1 and 5

millimeters. As a result of the offset, the bodies are provided in left and right versions which are mirror images of each other.

In the disclosed embodiment, the tapered bore is positioned approximately 1 millimeter offset from the center of the head as depicted at 227 in Fig. 24. This offset allows the surgeon to rotate the head to achieve any desired offset between 1 and 3 millimeters. By offsetting the tapered stud from the anterior/posterior plane, the surgeon is able to achieve a range of posterior offsets without introducing excessive superior/inferior offsets. Although the head is shown with an offset, it is possible that the head might not have any offset, thus eliminating any superior/inferior offset. One of the benefits of eliminating head offset is that it is possible to introduce the desired anterior/posterior offset via the body without introducing other perturbations into the positioning of the head. It is generally desirable to keep the head offset to a minimum to reduce the torque created by the offset.

In addition to providing the body in left and right versions, it may be desirable to provide multiple left and right bodies with various offsets. Because heads are substantially more costly to produce than bodies, providing multiple bodies offers a more economical approach to achieving a wide variety of anatomical offsets. The body can be manufactured by machining from bar stock or may be cast. Another benefit of providing side-specific bodies is that the size of the body can be kept to a minimum in comparison to adjustable bodies. Minimizing the size of the body reduces the amount of bone that must be removed to install the implant.

It should be noted that the anterior/posterior offset described in the context of a cylindrical taper lock could also be implemented on the dovetail taper lock previously described by simply offsetting the taper lock in the head or on the body or both.

5 While the invention has been disclosed in its preferred form, the specific embodiments thereof as disclosed and illustrated herein are not to be considered in a limiting sense as numerous variations are possible. Applicant regards the subject matter of his invention to include all novel and non-obvious combinations and subcombinations of the various elements, features, functions and/or properties disclosed herein. No single
10 feature, function, element or property of the disclosed embodiments is essential. The following claims define certain combinations and subcombinations which are regarded as novel and non-obvious. Other combinations and subcombinations of features, functions, elements and/or properties may be claimed through amendment of the present claims or presentation of new claims in this or a related application. Such claims, whether they are
15 broader, narrower or equal in scope to the original claims, are also regarded as included within the subject matter of applicant's invention.

CLAIMS

1. A shoulder prosthesis comprising:
 - a head having a rear surface;
 - an elongate stem portion including a proximal end for connection to the head and a distal section for insertion into a medullary canal of a humeral bone; and
 - a conical taper lock structure for joining the head to the stem portion whereby the head can be joined to the stem portion without regard for the angular orientation of the head about an axis perpendicular to the rear surface, the taper lock structure including male and female portions, one portion disposed on the rear surface of the head and the other portion being disposed on the proximal end of the stem portion, with the portion of the taper lock structure on the stem portion having a predetermined offset from an anterior/posterior plane of the stem portion.

2. The prosthesis of claim 1, further comprising an alignment section disposed between the proximal end and distal section, wherein the alignment section includes a plurality of reference marks positioned to facilitate placement of the prosthesis in the bone at a previously-determined position.

3. The prosthesis of claim 2, wherein the reference marks include an angular indication extending along the stem portion through at least part of the alignment section.

4. The prosthesis of claim 2, wherein the reference marks include a plurality of vertically-spaced gradations disposed at intervals along an axis of the stem portion over at least part of the alignment section.

5. The prosthesis of claim 1, wherein the stem portion further includes a body portion forming the proximal end of the stem portion.

6. The prosthesis of claim 1, wherein the male portion is disposed on the proximal end of the stem portion.

7. The prosthesis of claim 1, wherein the anterior/posterior offset of the portion of the taper lock structure on the stem portion is more than 1 millimeter.

8. The prosthesis of claim 1, wherein the rear surface of the head is substantially circular in profile and the portion of the taper lock structure on the head is offset from the center of the circular rear surface.

9. The prosthesis of claim 8, wherein the offset from the center of the rear surface is at least approximately 1 millimeter.

10. The prosthesis of claim 8, wherein the offset from the center of the rear surface is less than approximately 3 millimeters.

11. The prosthesis of claim 1, wherein the stem portion further includes a collar at the proximal end to prevent the stem portion from subsiding into the humerus.

12. A shoulder prosthesis comprising:

a head having a semi-spherical articulation surface bounded by a generally planar articular margin bounding a rear surface disposed generally normal to a head axis, the head further having a tapered cylindrical socket extending inward from the rear surface; and

a stem portion including a proximal end and a distal shaft for insertion into the medullary canal of a humerus, the distal shaft being configured to lie in an anterior/posterior plane when installed in the humerus, the proximal end including a tapered cylindrical stud having an axis which is oriented parallel to and offset from the anterior/posterior plane when the stem portion is installed in the humerus.

13. The prosthesis of claim 12, wherein the stud axis is offset from the anterior/posterior plane by at least 1 millimeter.

14. The prosthesis of claim 12, wherein the rear surface is generally circular in planform and the tapered cylindrical socket is offset relative to the center of the rear surface.

15. The prosthesis of claim 14, wherein the offset of the tapered cylindrical socket is at least 1 millimeter.

16. The prosthesis of claim 12, wherein the stem portion further includes a collar projecting transverse to a cylindrical axis of the stud generally parallel to the rear surface of the head when the head is mounted to the stem portion.

17. A shoulder prosthesis kit comprising:
at least one head adapted to replace the head of a humerus;
at least one distal shaft adapted to be inserted into the medullary canal of a humerus; and
left and right body portions adapted to couple the head to the distal shaft at different positions relative to each other.

18. The kit of claim 17, wherein the left and right body portions are mirror images of each other.

19. The kit of claim 17, wherein the left and right body portions are mirror images of each other about an anterior/posterior plane.

20. The kit of claim 17, wherein the left and right body portions position the head with a posterior offset in left and right humeri, respectively.

21. The kit of claim 17, further including a taper lock structure with male and female portions, one portion being disposed on the head and a mating portion being disposed on each of the bodies.

22. The kit of claim 21, wherein the male portion of the taper lock structure is a tapered cylinder.

23. The kit of claim 22, wherein portions mounted to each of the bodies are male portions.

24. The kit of claim 21, wherein the male portion of the taper lock structure is a tapered dovetail.



Application No: GB 9904881.1
Claims searched: 1-24

Examiner: Mrs Susan Chalmers
Date of search: 13 May 1999

Patents Act 1977
Search Report under Section 17

Databases searched:

UK Patent Office collections, including GB, EP, WO & US patent specifications, in:

UK CI (Ed.Q): -

Int CI (Ed.6): -

Other: ONLINE: EPODOC, WPI, JAPIO

Documents considered to be relevant:

Category	Identity of document and relevant passage	Relevant to claims
P,X	WO 98/46172 A1 (MINNESOTA MINING) see especially part 24 in Figures 5, 7, 11 and 13, page 4 lines 17-19 and page 9 lines 26-32	1,5,6,11,12,16
Y	WO 96/17553 A1 (WRIGHT) see especially indicia means 45,47, Figures 1 and 5 and page 10 lines 15-26	2
X Y	EP 0679375 A1 (EUROS) see Figures 4 and 5 and column 4 line 58 to page 5 line 16	1,11,12,16 2
A	EP 0617934 A1 (LANDANGER-LANDOS) see Figures 6-10	
X Y	EP 0339530 A2 (S+G IMPLANTS) see Figures 1 and 2	1,6-16 2
A	US 4919670 (INTERMEDICS) see eg Figures 1 and 2	

X Document indicating lack of novelty or inventive step
Y Document indicating lack of inventive step if combined with one or more other documents of same category.

& Member of the same patent family

A Document indicating technological background and/or state of the art.
P Document published on or after the declared priority date but before the filing date of this invention.

E Patent document published on or after, but with priority date earlier than, the filing date of this application.