



US00D764975S

(12) **United States Design Patent** (10) **Patent No.:** **US D764,975 S**  
**Aengenheyster** (45) **Date of Patent:** **\*\* Aug. 30, 2016**

(54) **MOTOR CAR**  
(71) Applicant: **GM Global Technology Operations LLC, Detroit, MI (US)**  
(72) Inventor: **Carsten Aengenheyster, Bickenbach (DE)**  
(73) Assignee: **GM Global Technology Operations LLC, Detroit, MI (US)**  
(\*\*) Term: **14 Years**

D605,977 S 12/2009 Zipfel et al.  
D605,978 S 12/2009 Wolff et al.  
D608,249 S 1/2010 Peters  
D608,690 S 1/2010 Folden et al.  
D608,691 S 1/2010 Zak, Jr. et al.  
D609,608 S 2/2010 Boniface et al.  
D611,387 S 3/2010 Thompson et al.  
D611,879 S 3/2010 Kim et al.  
D612,297 S 3/2010 Peters et al.  
D613,645 S 4/2010 Song et al.  
D615,458 S 5/2010 Thompson et al.  
D618,595 S 6/2010 Ware et al.  
D623,090 S 9/2010 Cox et al.  
D627,262 S 11/2010 Ikeda et al.  
D635,488 S 4/2011 Phipps

(21) Appl. No.: **29/518,143**

(22) Filed: **Feb. 20, 2015**

(30) **Foreign Application Priority Data**

Aug. 21, 2014 (EM) ..... 002 522 698

(51) **LOC (10) CL.** ..... **12-08**

(52) **U.S. CL.**  
USPC ..... **D12/91**

(58) **Field of Classification Search**  
USPC ..... D12/86, 90-92; D21/421, 433, 434;  
296/181.1, 181.5  
CPC ..... B62D 35/00; B62D 25/00; B62D 25/06;  
B62D 25/08; B62D 33/00  
See application file for complete search history.

(56) **References Cited**

**U.S. PATENT DOCUMENTS**

D570,742 S 6/2008 Takagi et al.  
D592,105 S 5/2009 Dean et al.  
D597,447 S 8/2009 Folden  
D600,595 S 9/2009 Nakamura et al.  
D601,925 S 10/2009 O'Donnell  
D603,755 S 11/2009 Peters  
D604,203 S 11/2009 O'Donnell  
D605,082 S 12/2009 Munson  
D605,083 S 12/2009 Manoogian, II et al.

(Continued)

**OTHER PUBLICATIONS**

Design U.S. Appl. No. 29/439,307, filed Dec. 10, 2012; First Named Inventor: Brendon C. Mackay; Title: Vehicle Body Exterior.

(Continued)

*Primary Examiner* — Melody N Brown  
(74) *Attorney, Agent, or Firm* — Reising Ethington P.C.

(57) **CLAIM**

The ornamental design for a motor car, as shown and described.

**DESCRIPTION**

FIG. 1 is a front and left side perspective view of the motor car;  
FIG. 2 is a rear and right side perspective view thereof;  
FIG. 3 is a left side elevation view thereof;  
FIG. 4 is a right side elevation view thereof;  
FIG. 5 is a front elevation view thereof;  
FIG. 6 is a rear elevation view thereof; and,  
FIG. 7 is a top plan view thereof.  
The broken lines shown in the drawings depict portions of the motor car that form no part of the claimed design.

**1 Claim, 6 Drawing Sheets**

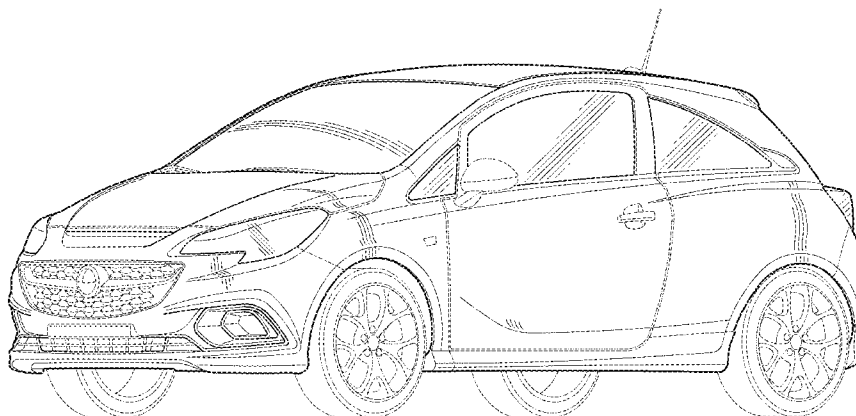

(56)

References Cited

OTHER PUBLICATIONS

U.S. PATENT DOCUMENTS

D644,147 S 8/2011 Suh et al.  
 D644,567 S 9/2011 Kozub  
 D657,718 S 4/2012 Zipfel et al.  
 D659,052 S 5/2012 Ware et al.  
 D659,053 S 5/2012 Ware et al.  
 D668,182 S 10/2012 Franco  
 D668,183 S 10/2012 Smart  
 D678,820 S 3/2013 Son et al.  
 D678,821 S 3/2013 Ikeda et al.  
 D680,909 S 4/2013 Munson et al.  
 D680,910 S 4/2013 David  
 D684,899 S 6/2013 Baker  
 D686,536 S 7/2013 McCabe et al.  
 D692,798 S 11/2013 Thurber  
 D692,799 S 11/2013 Smith et al.  
 D696,157 S 12/2013 Loeb  
 D699,629 S 2/2014 Ikeda et al.  
 D700,871 S 3/2014 O'Donnell et al.  
 D703,103 S 4/2014 Lee  
 D704,103 S 5/2014 Mack et al.  
 D705,132 S 5/2014 Ware et al.  
 D705,699 S 5/2014 Ware et al.  
 D713,298 S 9/2014 Dyson  
 D713,764 S 9/2014 Ferlazzo  
 D716,696 S 11/2014 Thole et al.  
 D717,696 S 11/2014 Thole et al.  
 D718,189 S 11/2014 Krieg et al.  
 D722,282 S 2/2015 Loeb  
 D722,533 S 2/2015 Thole et al.  
 D722,534 S 2/2015 Munson et al.  
 D732,432 S \* 6/2015 Aengenheyster ..... D12/91  
 D732,433 S \* 6/2015 Aengenheyster ..... D12/91

Design U.S. Appl. No. 29/475,782, filed Dec. 6, 2013; First Named Inventor: Niels Loeb; Title: Motor Car.  
 Design U.S. Appl. No. 29/478,287, filed Jan. 3, 2014; First Named Inventor: Boris Jacob; Title: Motor Car.  
 Design U.S. Appl. No. 29/478,501, filed Jan. 6, 2014; First Named Inventor: Robert B. McMahan; Title: Vehicle Body Exterior.  
 Design U.S. Appl. No. 29/487,899, filed Apr. 14, 2014; First Named Inventor: Carsten Aengenheyster; Title: Motor Car.  
 Design U.S. Appl. No. 29/491,286, filed May 20, 2014; First Named Inventor: Robert B. McMahan; Title: Vehicle Body Exterior.  
 Design U.S. Appl. No. 29/492,639, filed Jun. 2, 2014; First Named Inventor: Jeasoo Kim; Title: Vehicle Body Exterior.  
 Design U.S. Appl. No. 29/498,301, filed Aug. 1, 2014; First Named Inventor: Niki J. Smart Title: Vehicle Body Exterior.  
 Design U.S. Appl. No. 29/499,464, filed Aug. 15, 2014; First Named Inventor: Niels Loeb; Title: Motor Car.  
 Design U.S. Appl. No. 29/499,467, filed Aug. 15, 2014; First Named Inventor: Niels Loeb; Title: Motor Car.  
 Design U.S. Appl. No. 29/499,475, filed Aug. 15, 2014; First Named Inventor: Niels Loeb; Title: Motor Car.  
 Design U.S. Appl. No. 29/499,479, filed Aug. 15, 2014; First Named Inventor: Carsten Aengenheyster; Title: Motor Car.  
 Design U.S. Appl. No. 29/499,480, filed Aug. 15, 2014; First Named Inventor: Carsten Aengenheyster; Title: Motor Car.  
 Design U.S. Appl. No. 29/499,824, filed Aug. 19, 2014; First Named Inventor: Niels Loeb; Title: Motor Car.  
 Design U.S. Appl. No. 29/499,829, filed Aug. 19, 2014; First Named Inventor: Niels Loeb; Title: Motor Car.  
 Design U.S. Appl. No. 29/506,337, filed Oct. 15, 2014; First Named Inventor: Timothy P. Kozub; Title: Vehicle Body Exterior.

\* cited by examiner

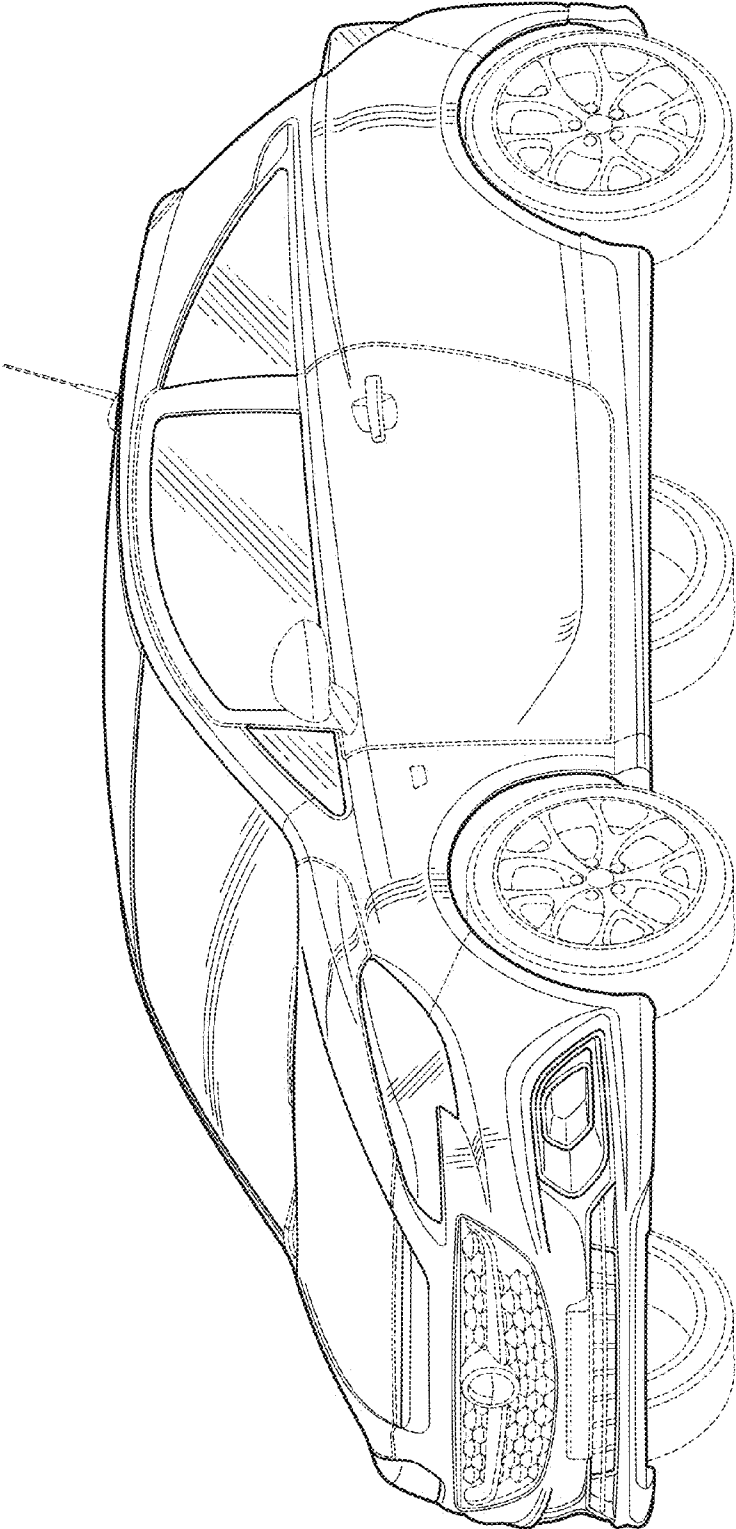

FIG. 1

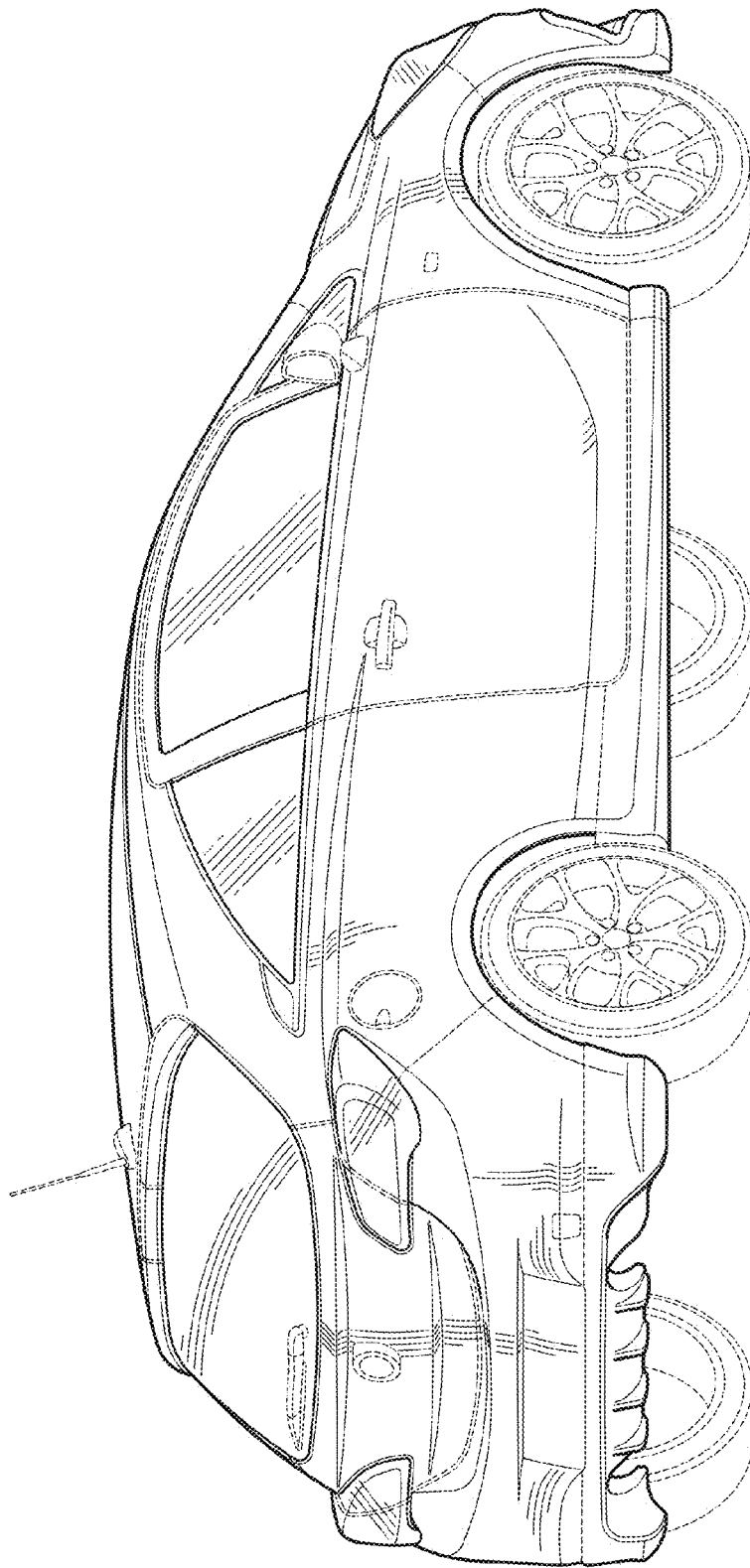

FIG. 2

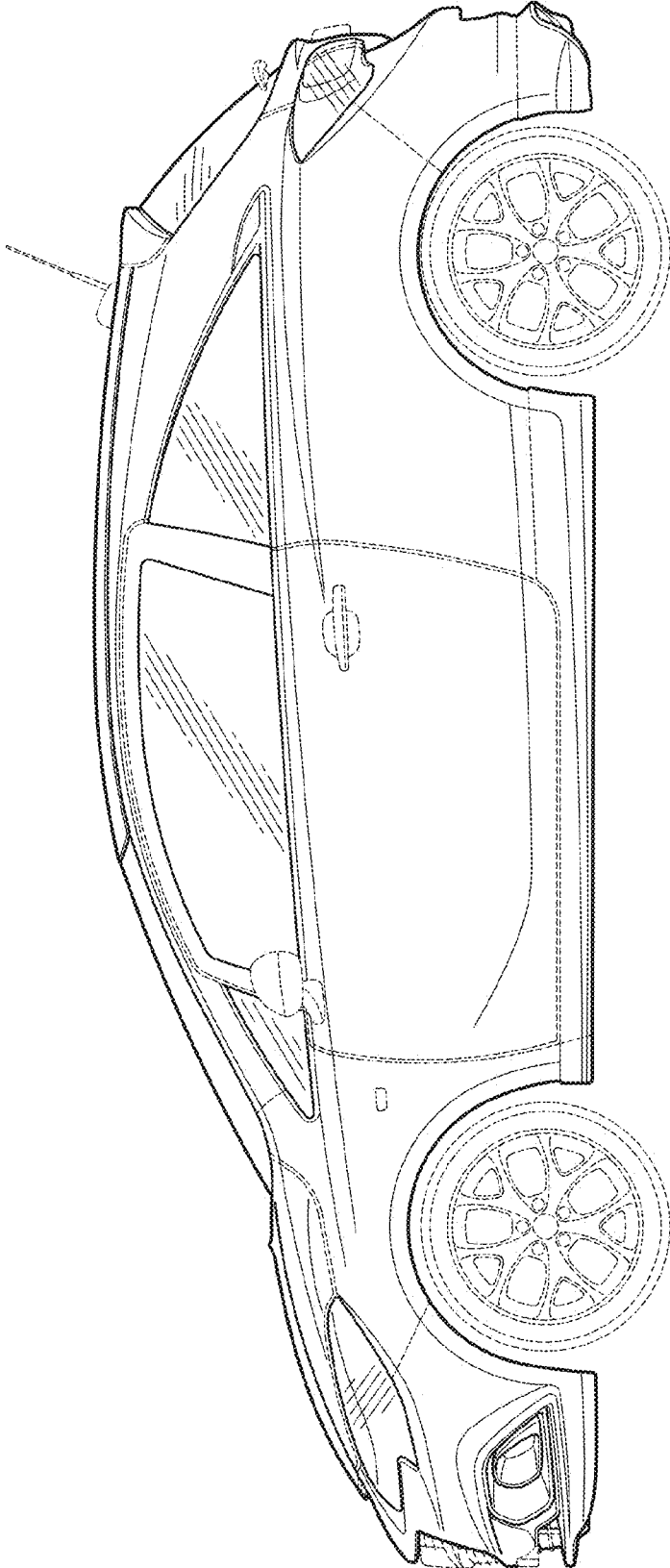

FIG. 3

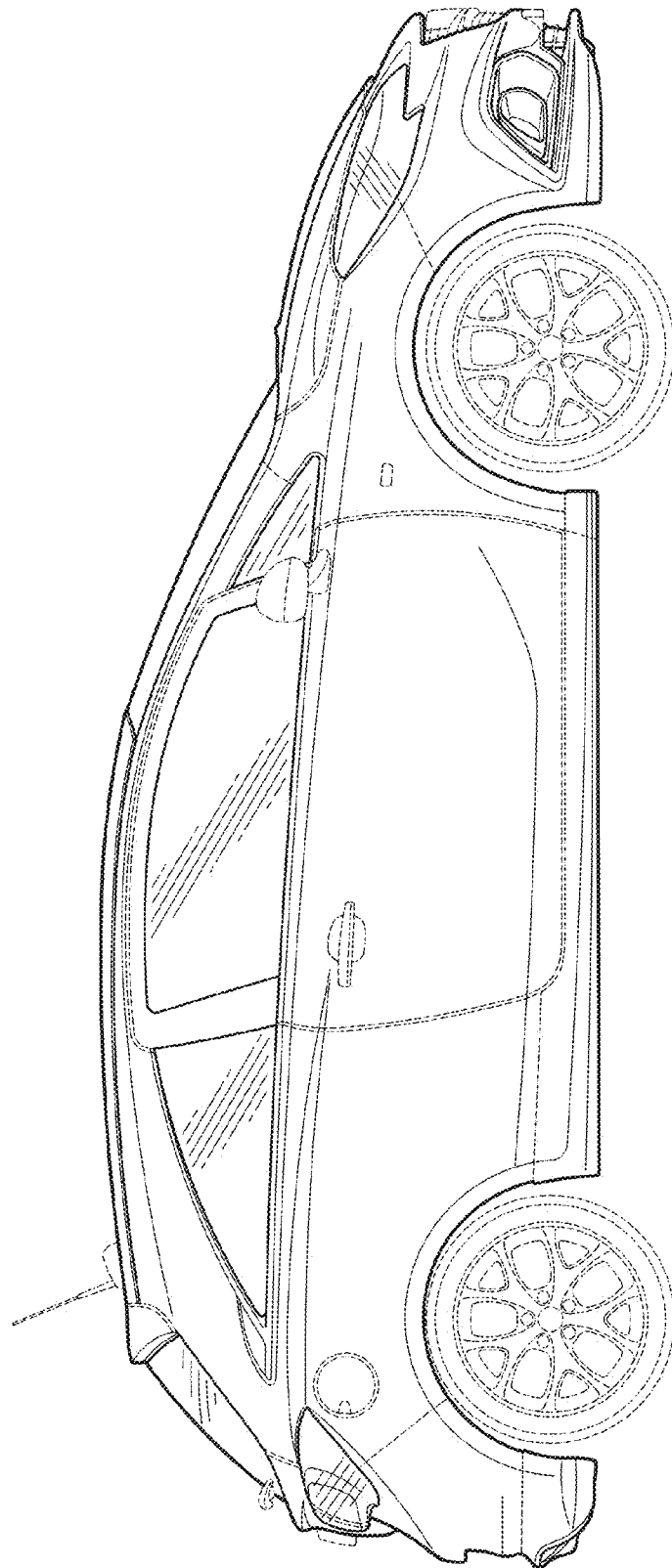

FIG. 4

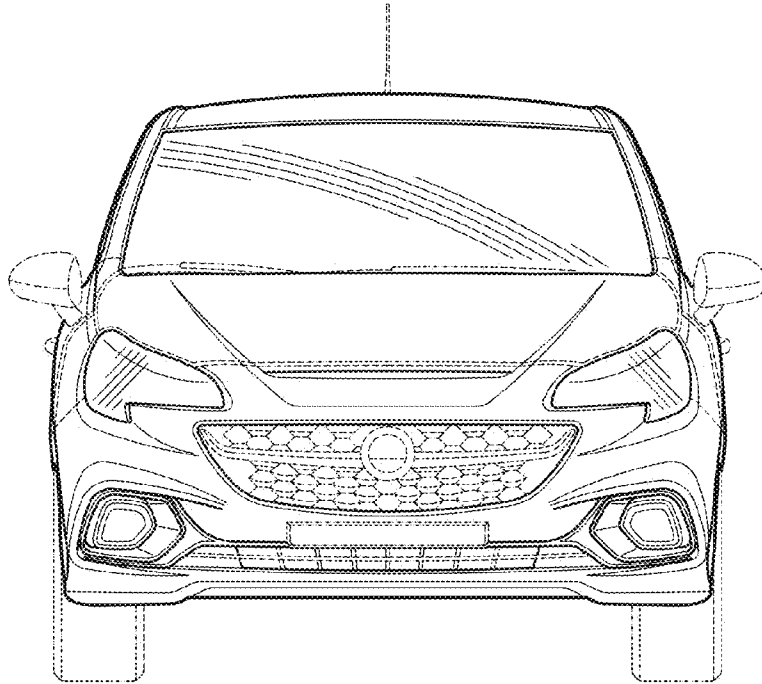

FIG. 5

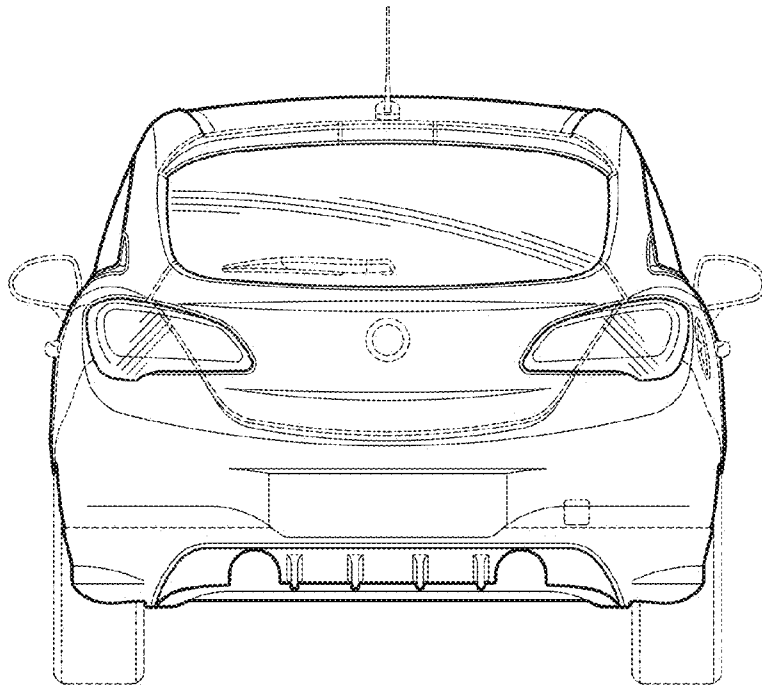

FIG. 6

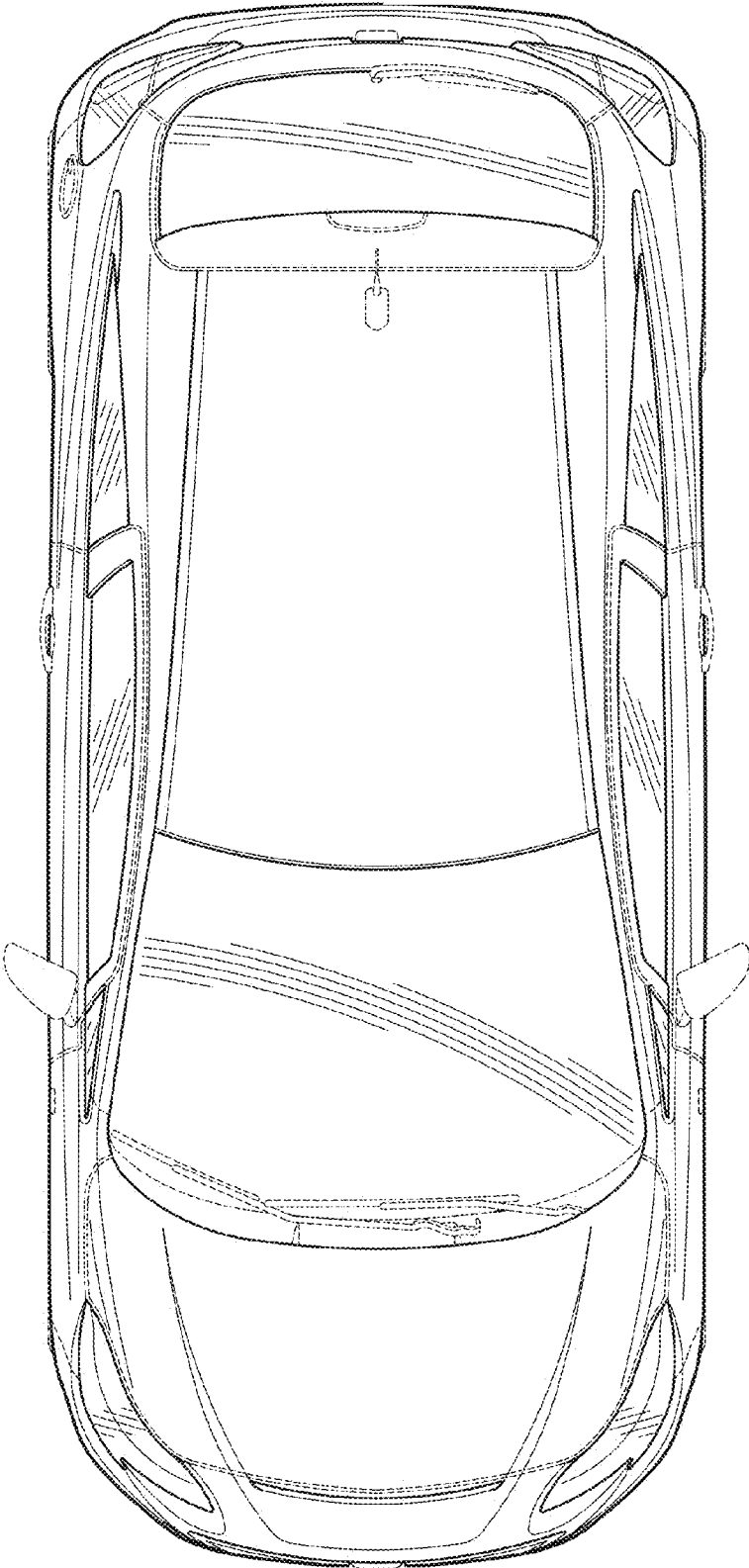

FIG. 7