



US 20050027362A1

(19) **United States**

(12) **Patent Application Publication**
Williams et al.

(10) **Pub. No.: US 2005/0027362 A1**

(43) **Pub. Date: Feb. 3, 2005**

(54) **METHOD AND APPARATUS FOR INTERVERTEBRAL IMPLANT ANCHORAGE**

continuation of application No. 09/259,503, filed on Feb. 26, 1999, now Pat. No. 6,113,638.

(76) Inventors: **Lytton A. Williams**, Rolling Hills Estates, CA (US); **Robert G. Watkins**, South Pasadena, CA (US)

Publication Classification

(51) **Int. Cl.⁷** **A61F 2/44**
(52) **U.S. Cl.** **623/17.11**

Correspondence Address:
STRADLING YOCCA CARLSON & RAUTH
SUITE 1600
660 NEWPORT CENTER DRIVE
P.O. BOX 7680
NEWPORT BEACH, CA 92660 (US)

(57) **ABSTRACT**

Methods and devices are provided for intervertebral implant anchorage. An implantable device for insertion into an intradiscal section between adjacent vertebrae is provided. The implantable device includes at least one anchor plate which comprises a plate member sized to be positioned within an intradiscal section between adjacent vertebrae and a plurality of anchoring elements extending from a surface of the plate member, each anchoring element including a distal portion capable of being introduced into the vertebra through the vertebral end plate; and an intradiscal component coupled to the anchor plate.

(21) Appl. No.: **10/894,914**

(22) Filed: **Jul. 19, 2004**

Related U.S. Application Data

(63) Continuation of application No. 09/644,026, filed on Aug. 22, 2000, now Pat. No. 6,800,092, which is a

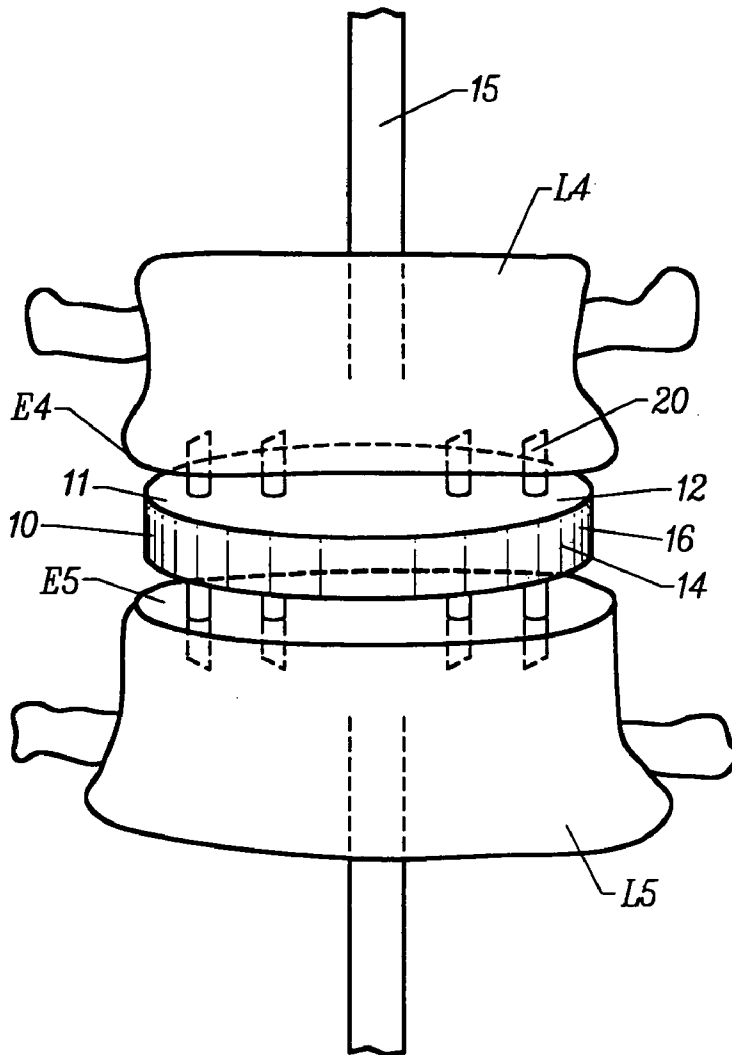

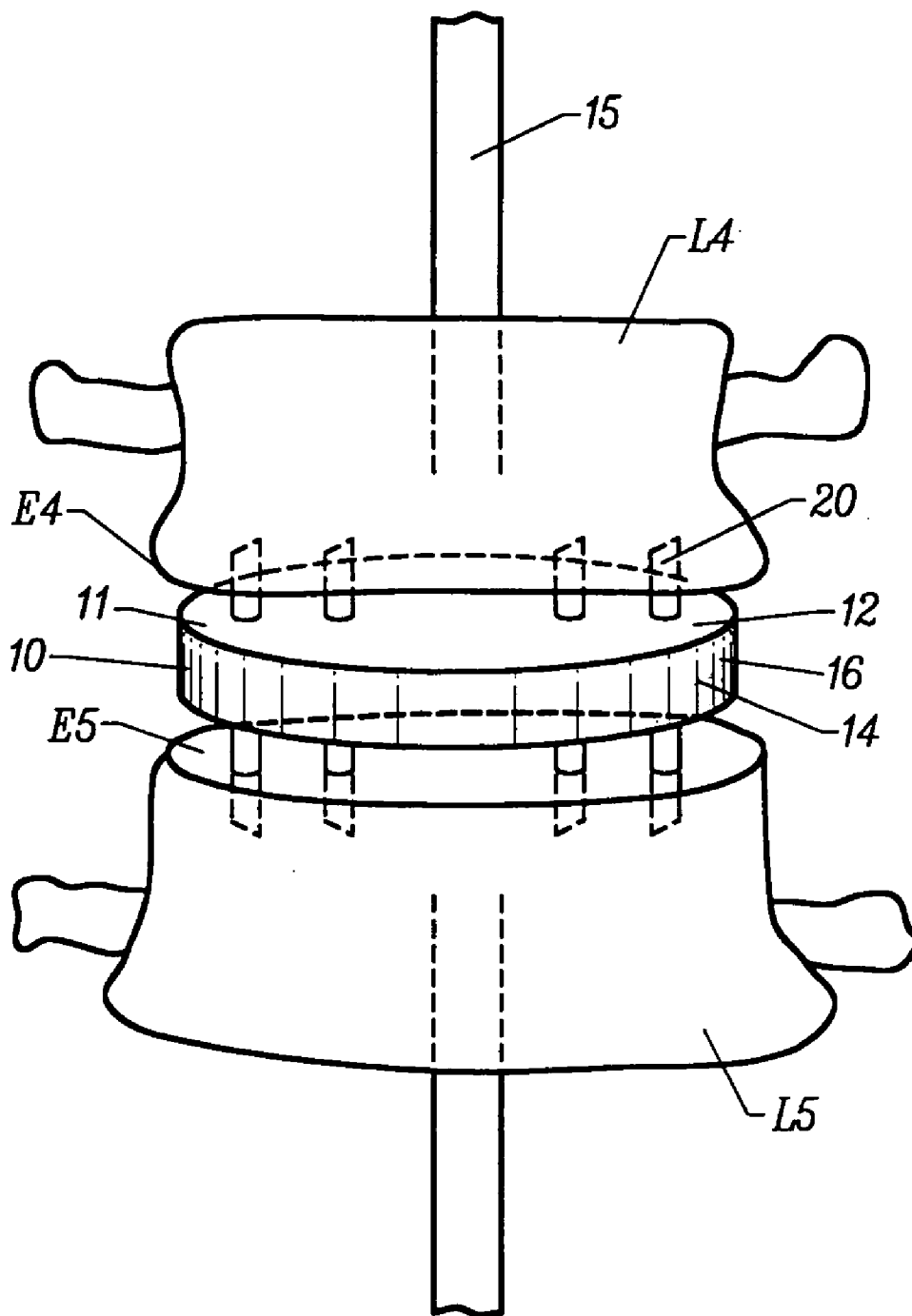

FIG. 1

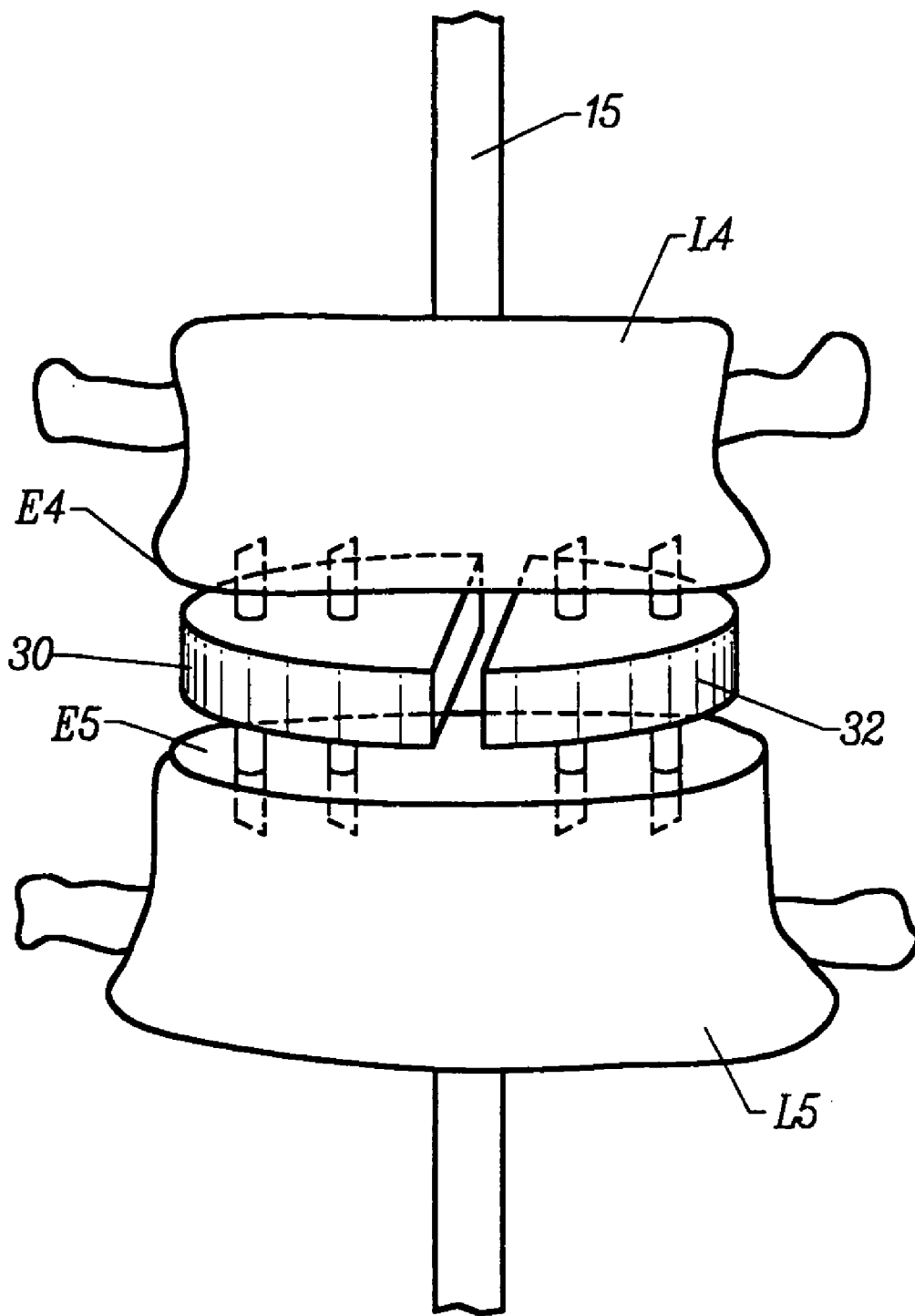

FIG. 2

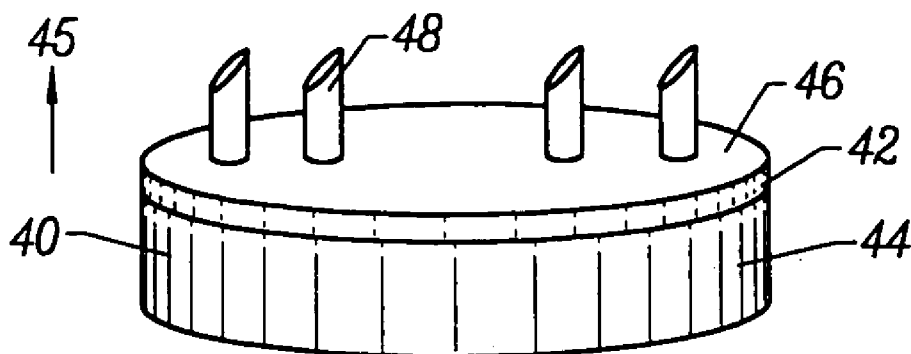

FIG. 3A

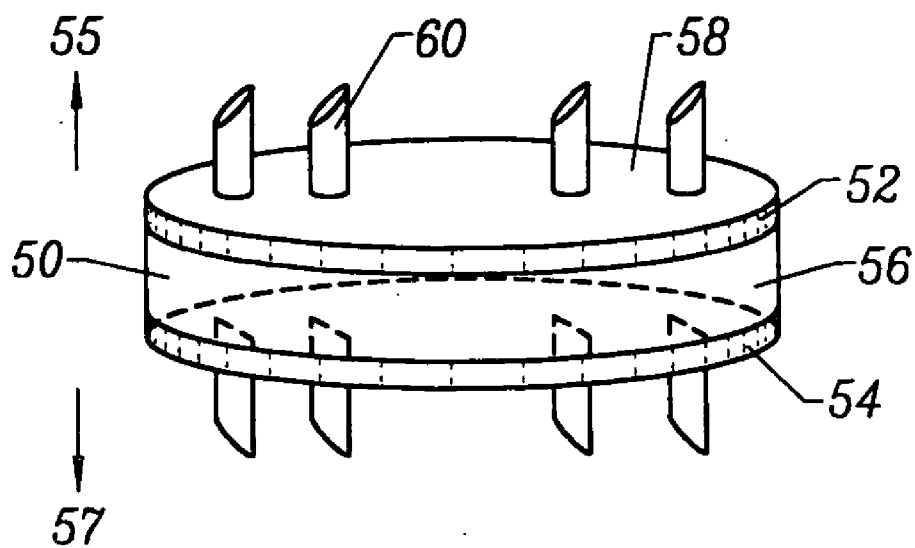

FIG. 3B

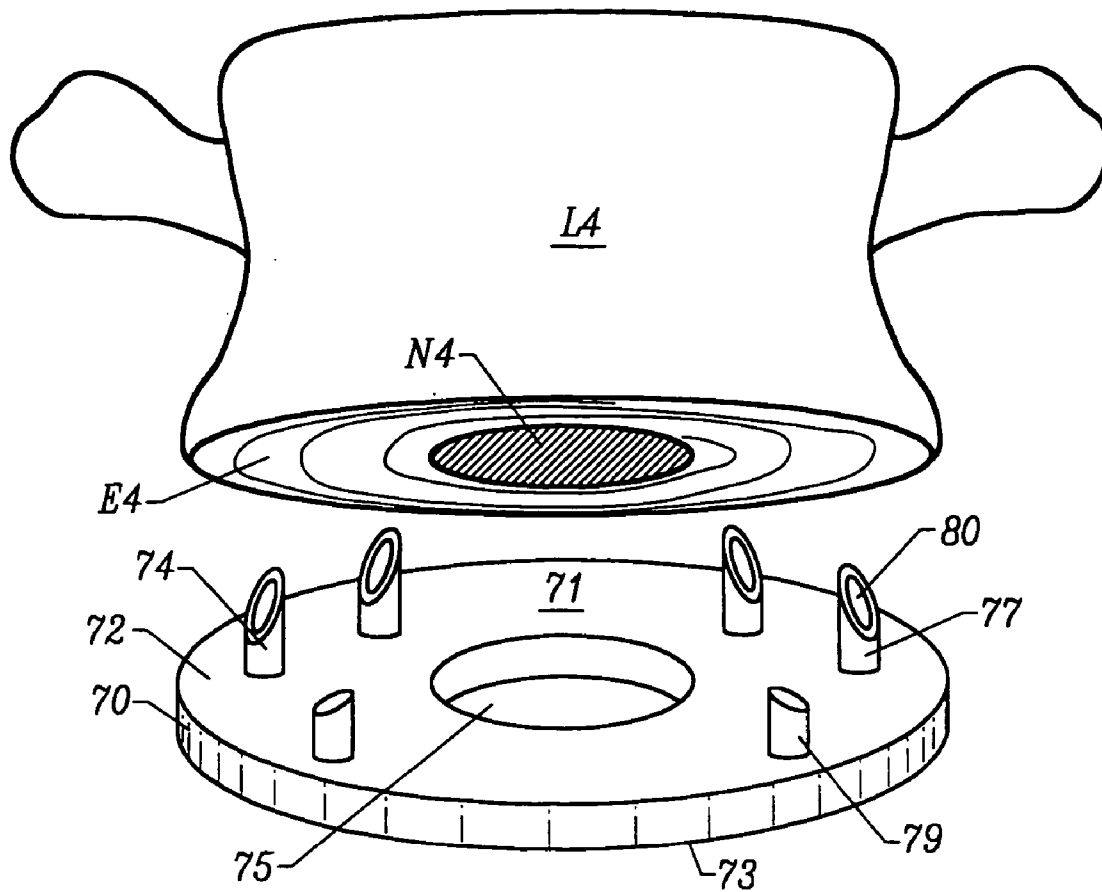

FIG. 4

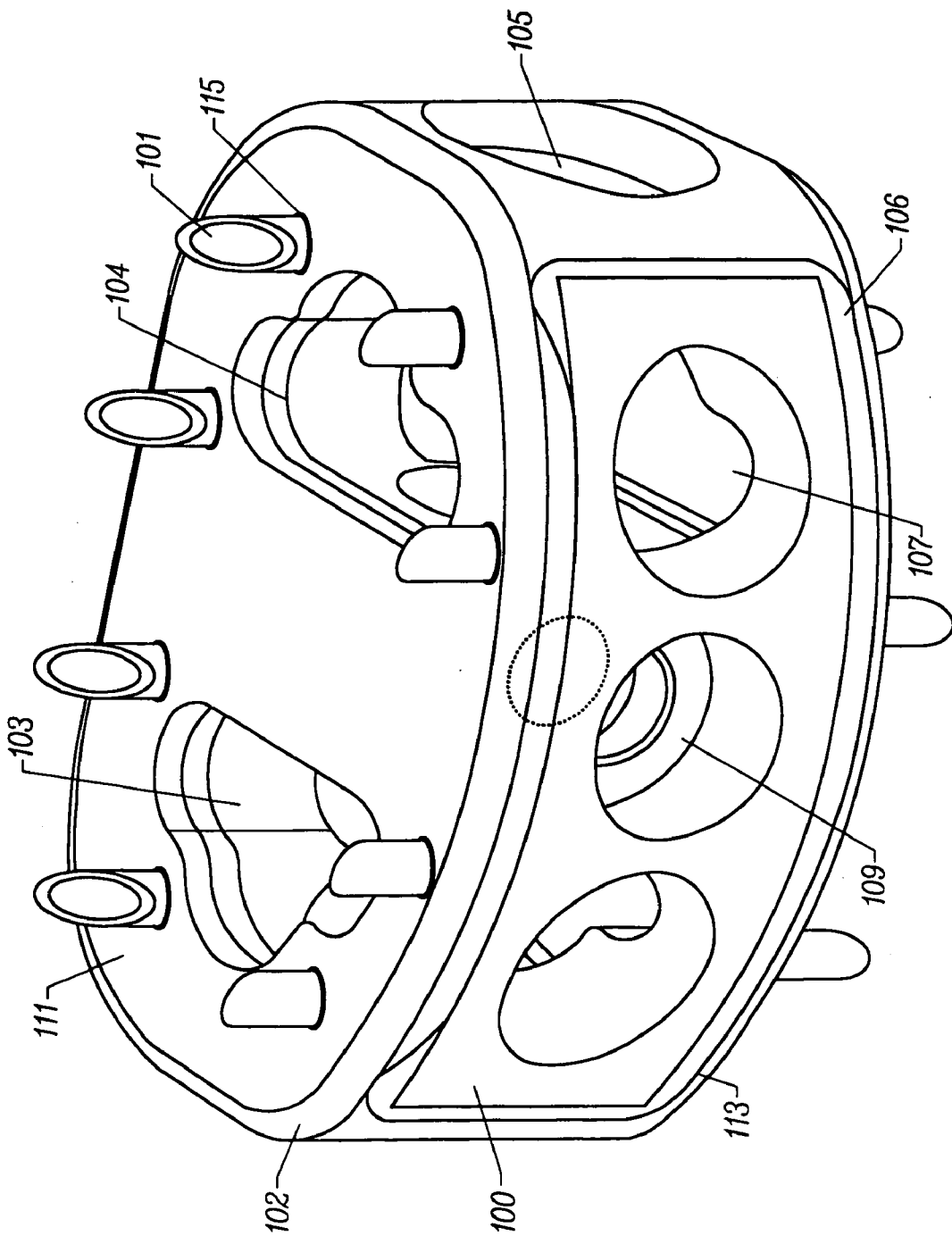

FIG. 5A

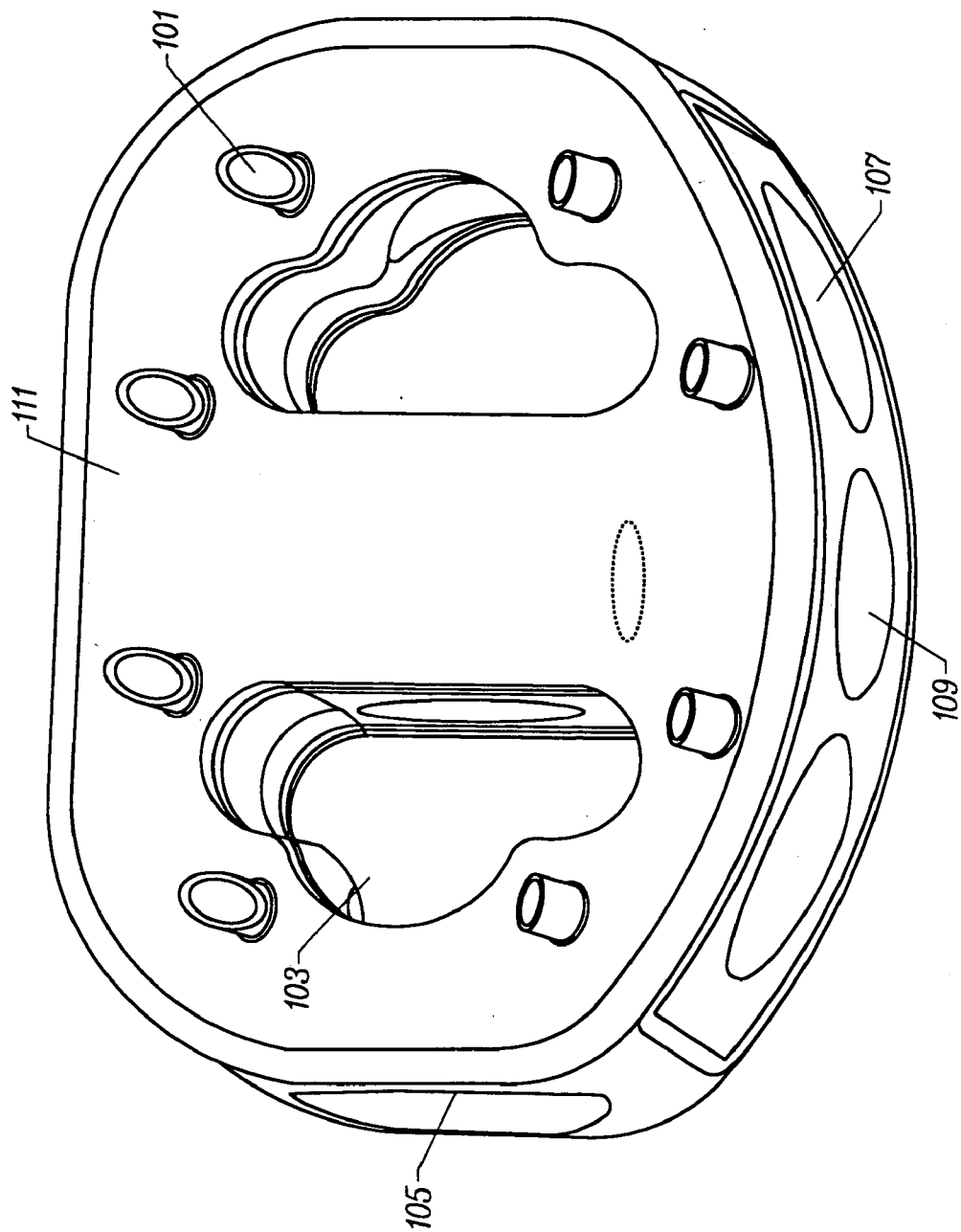

FIG. 5B

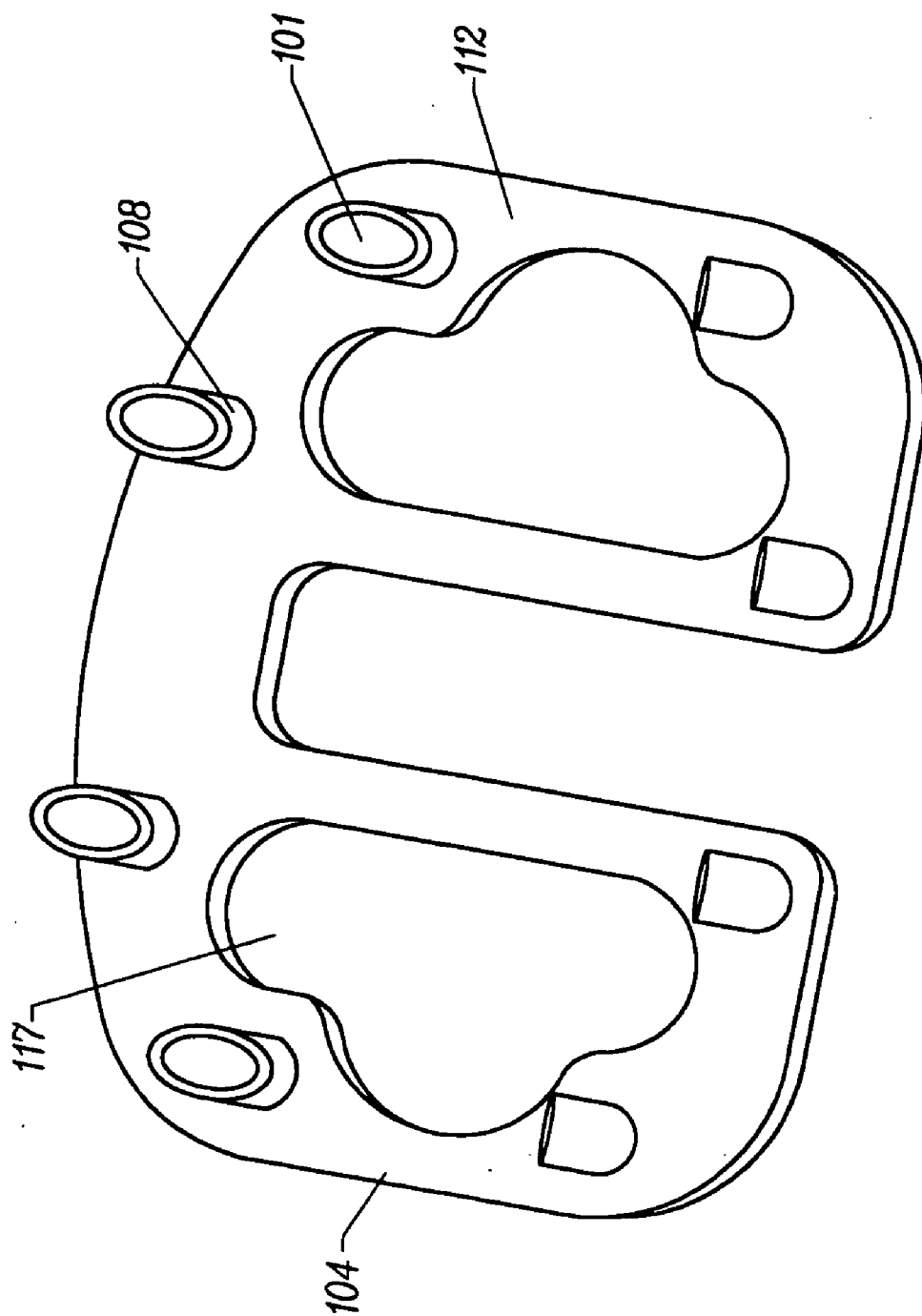

FIG. 5C

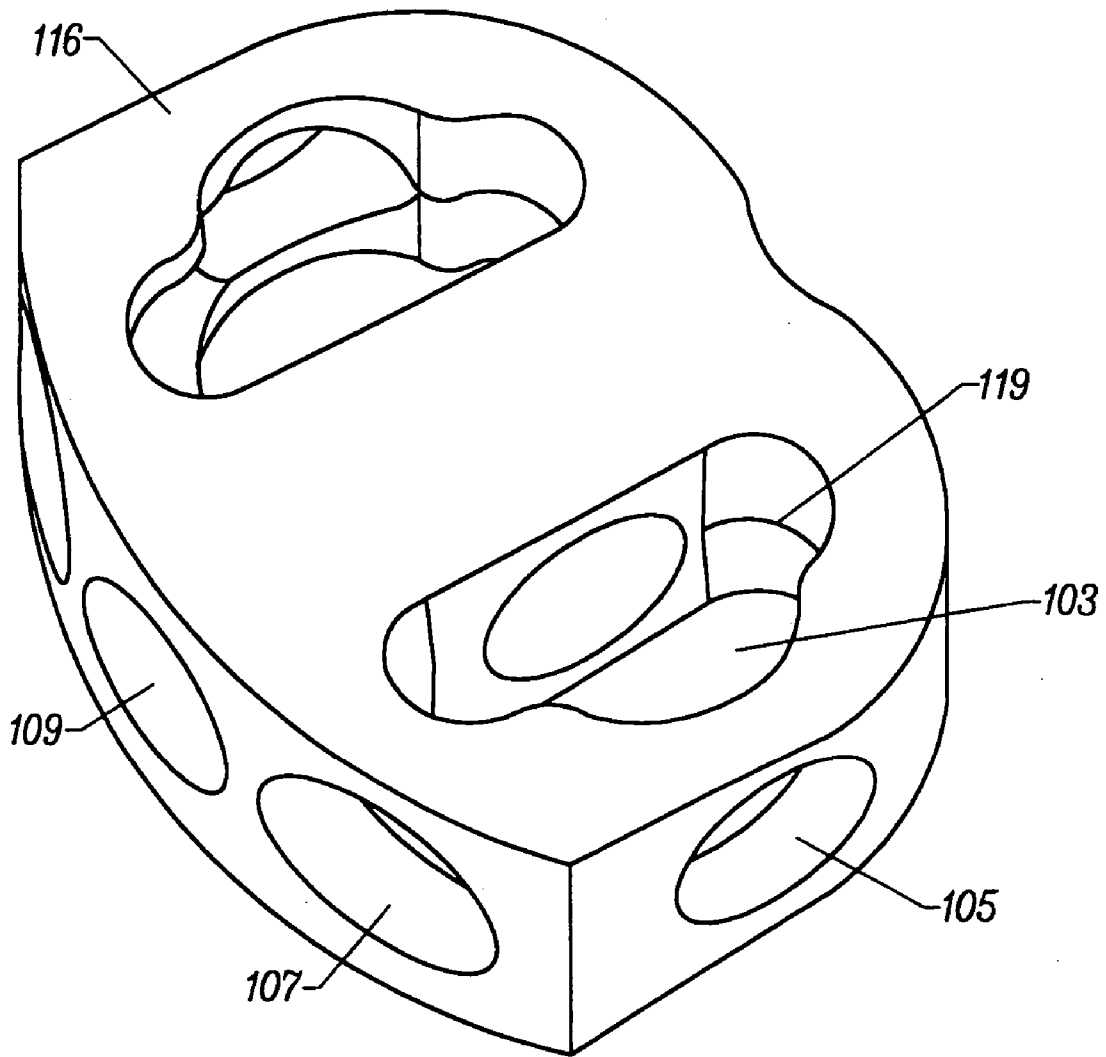

FIG. 5D

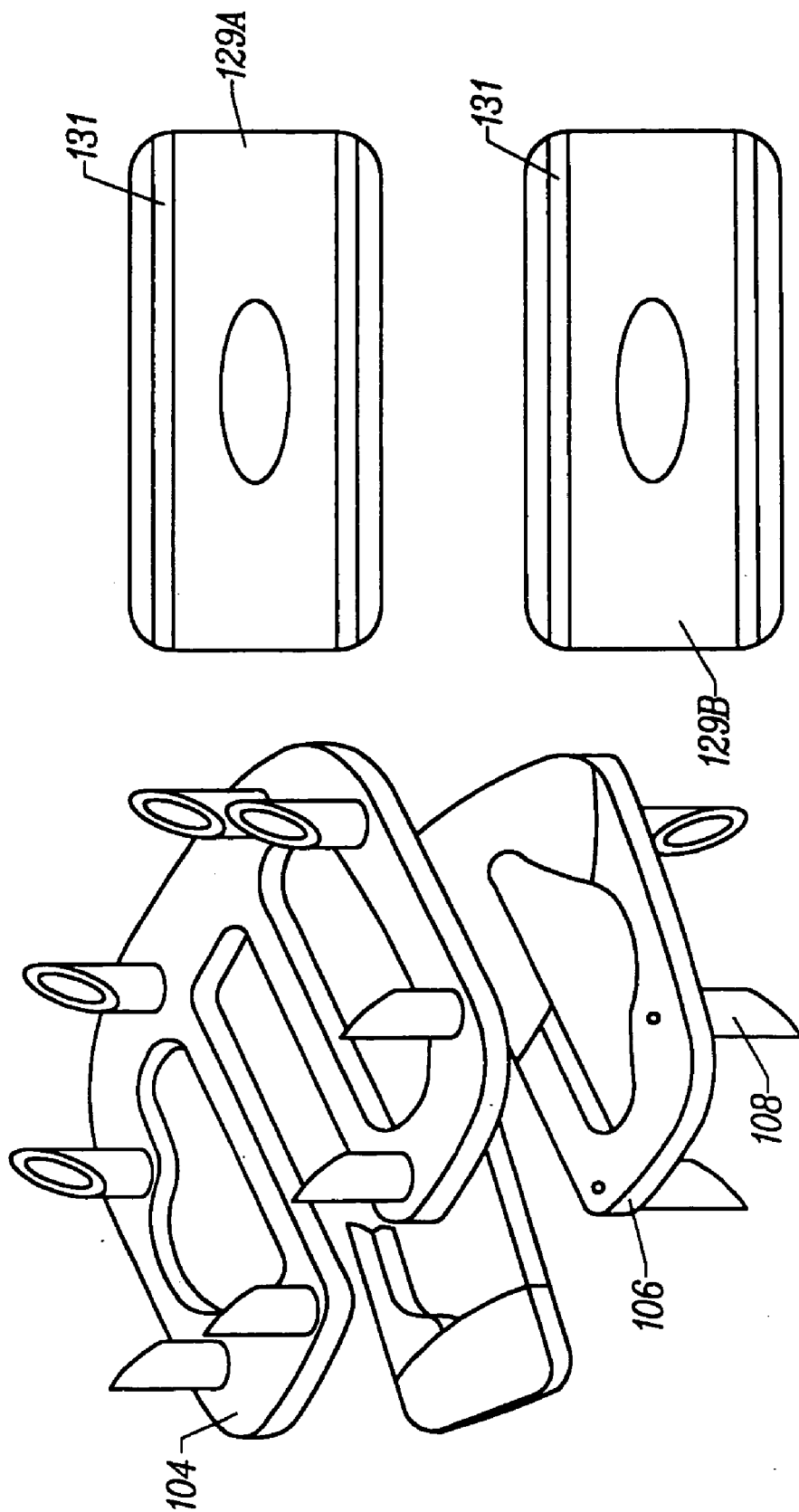

FIG. 5E

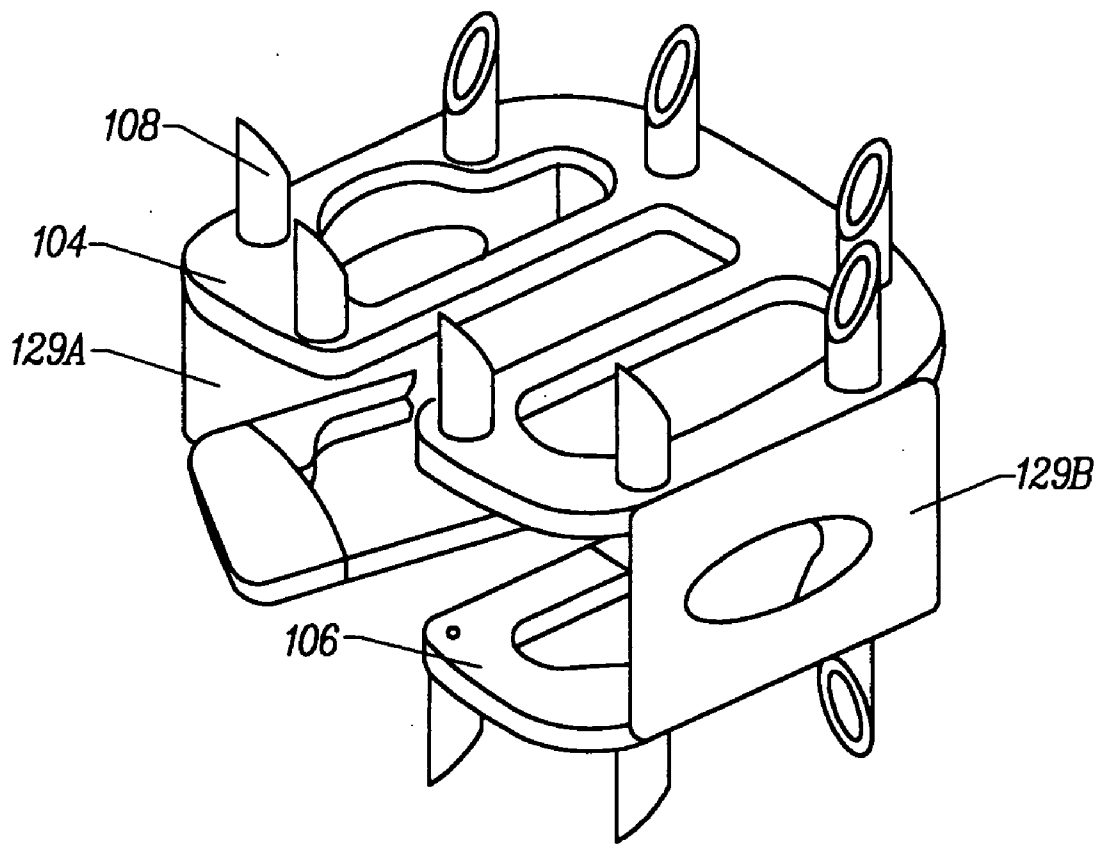

FIG. 5F

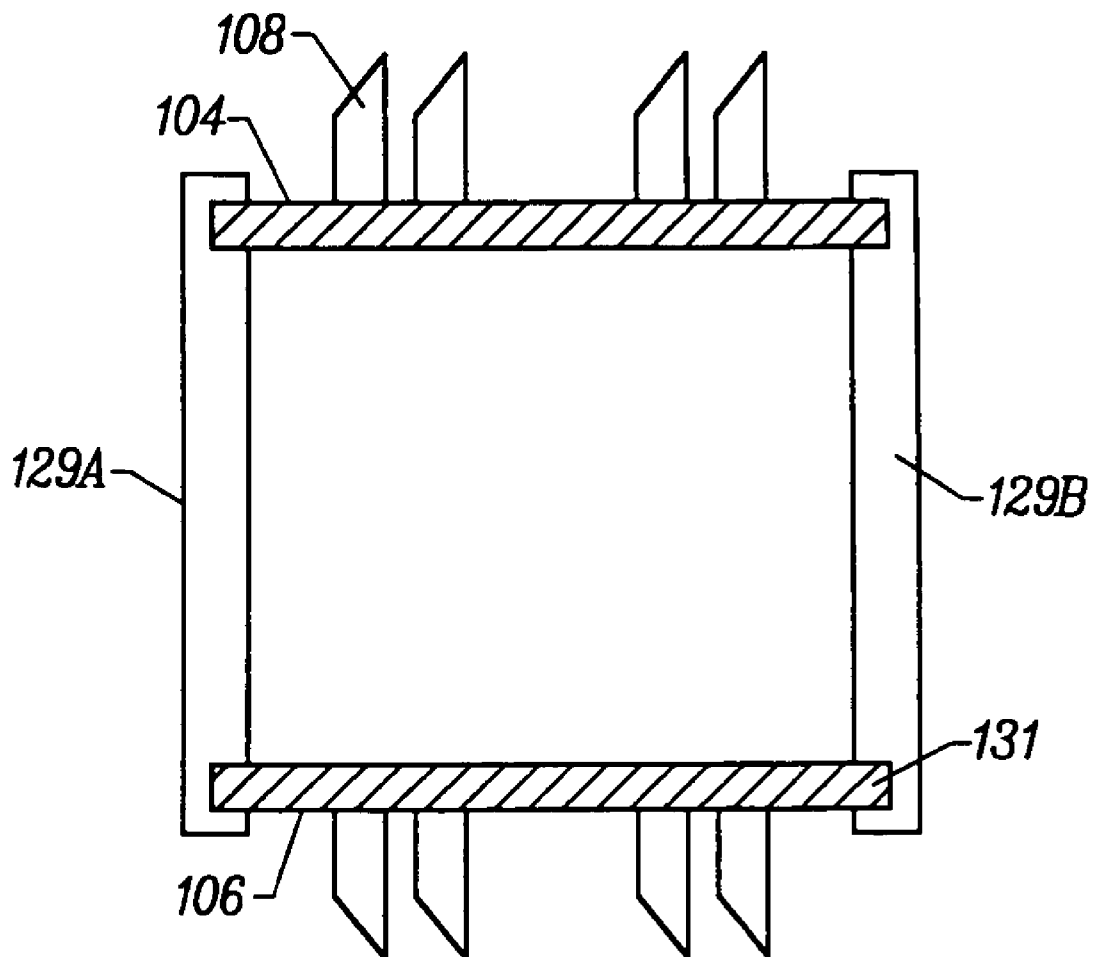

FIG. 5G

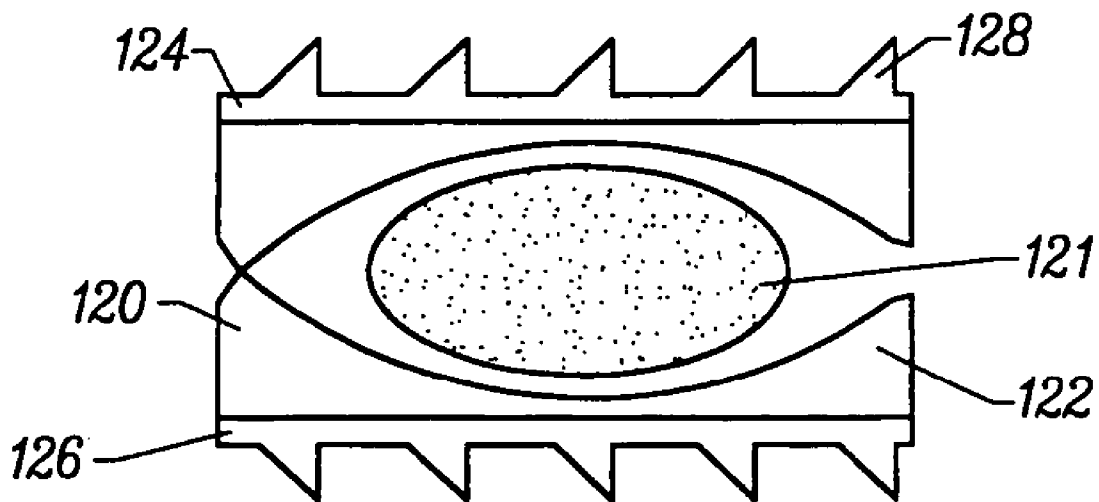

FIG. 6

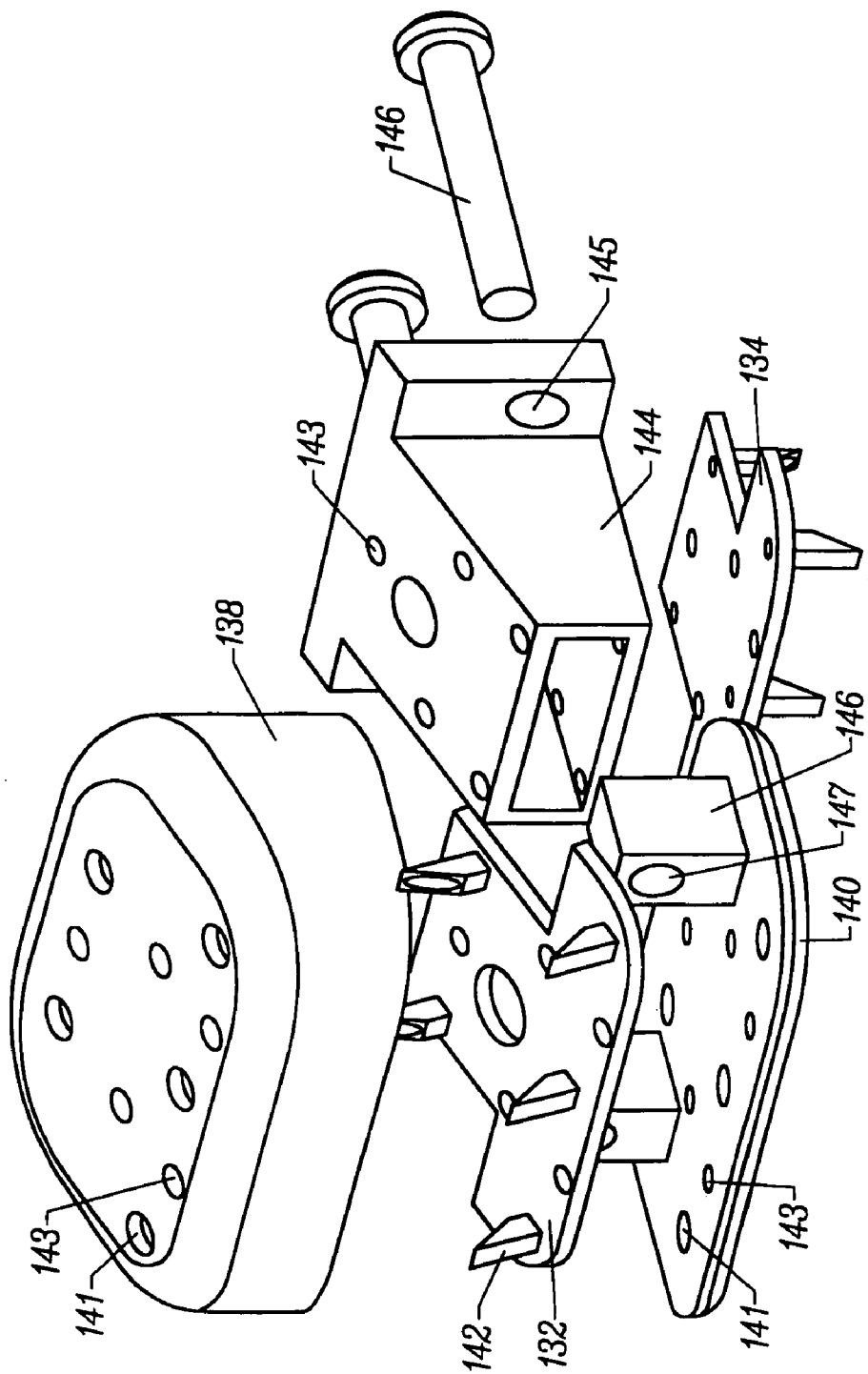

FIG. 7A

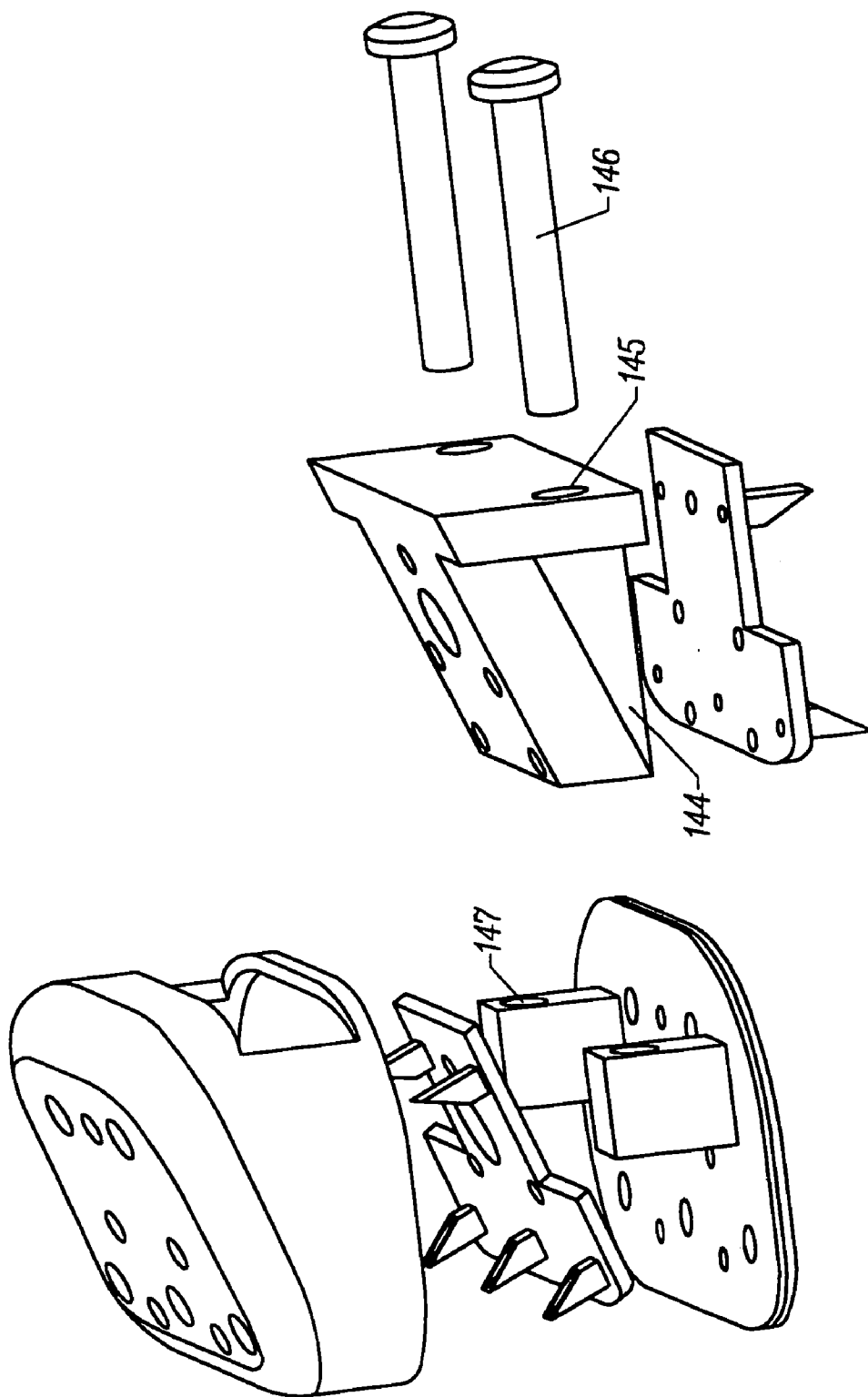

FIG. 7B

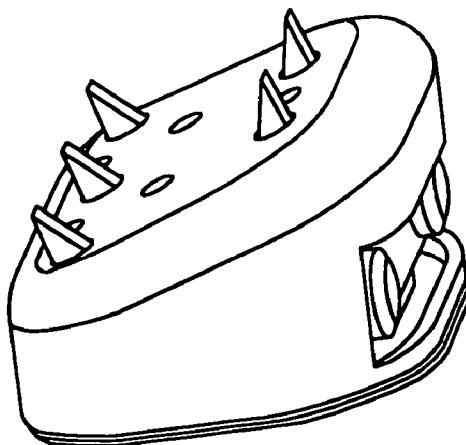

FIG. 7C

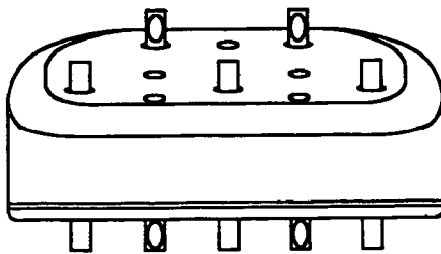

FIG. 7D

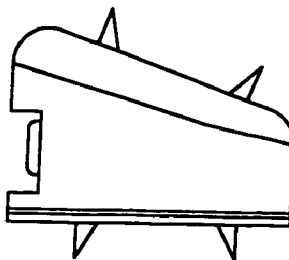

FIG. 7E

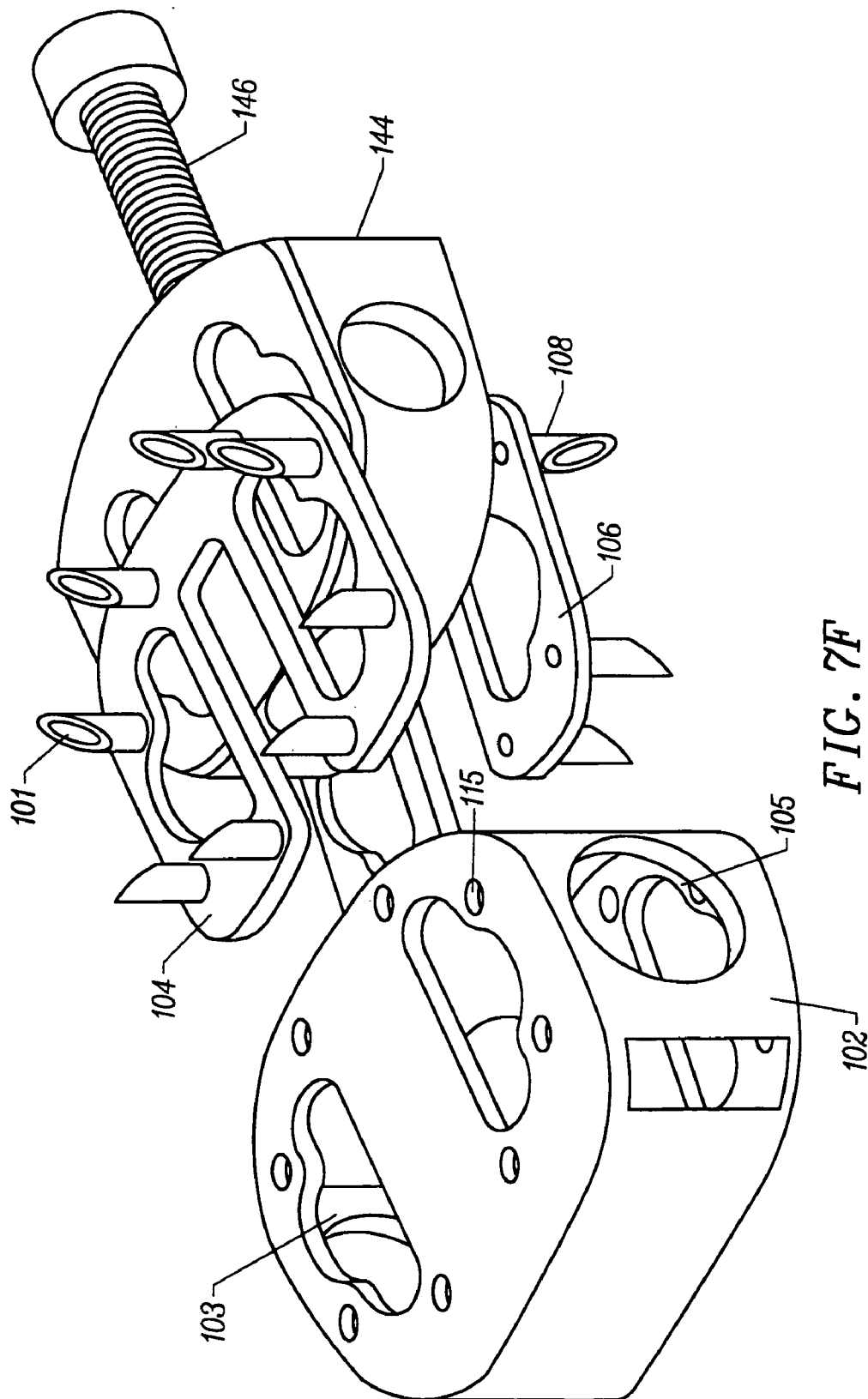

FIG. 7F

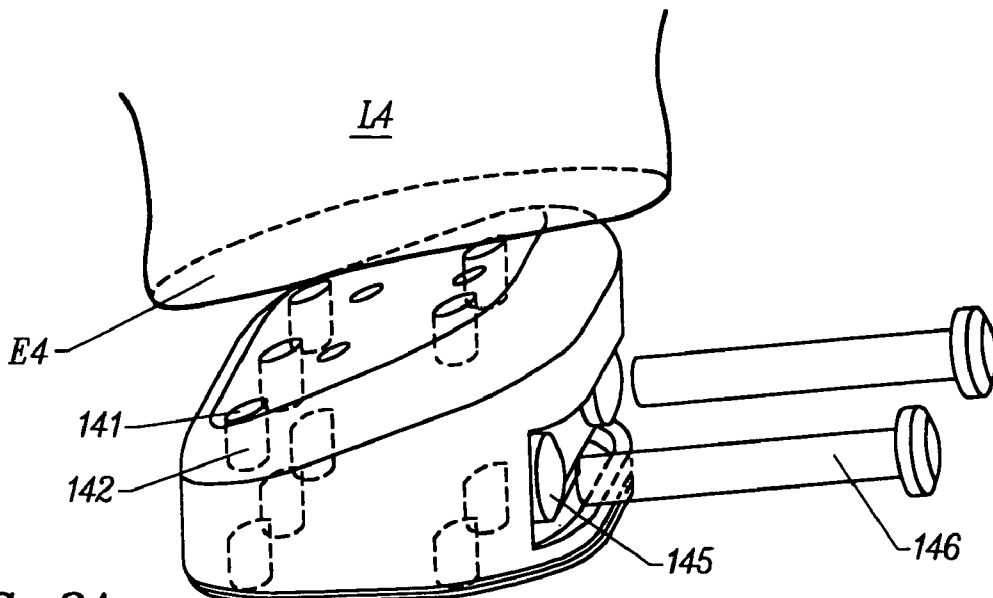

FIG. 8A

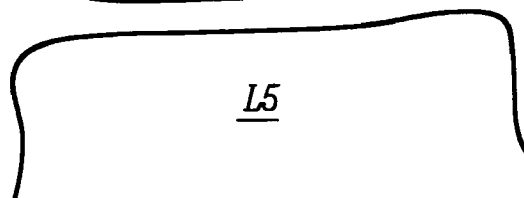
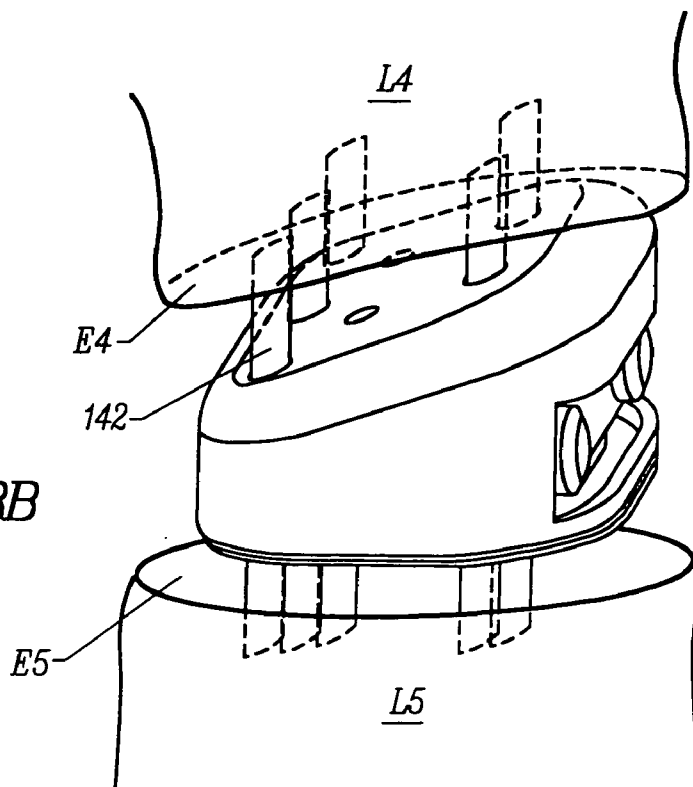

FIG. 8B



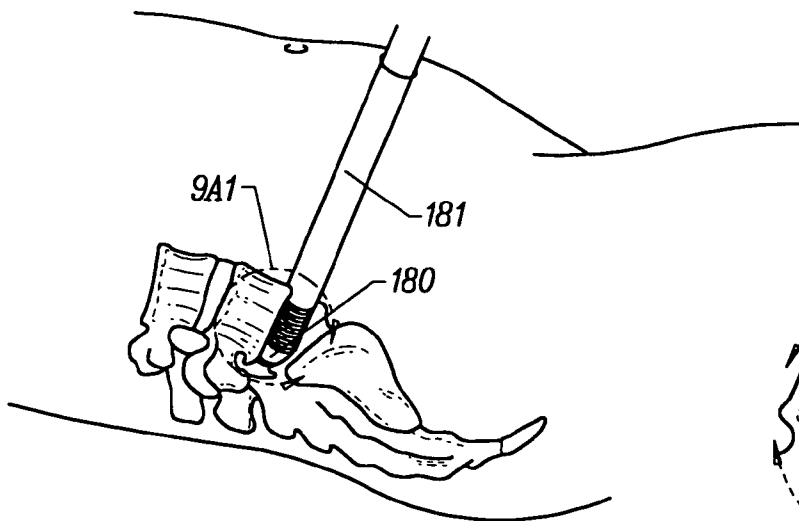

FIG. 9A

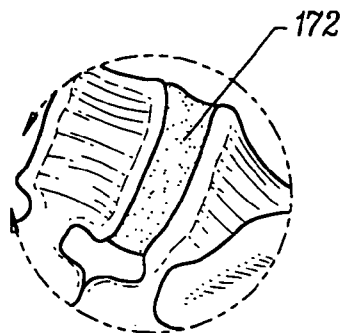

FIG. 9A1

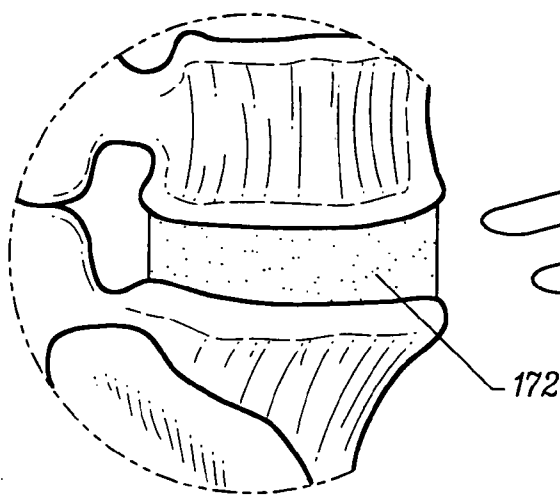

FIG. 9B

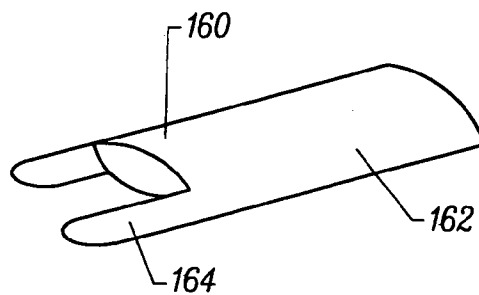

Figure 9C

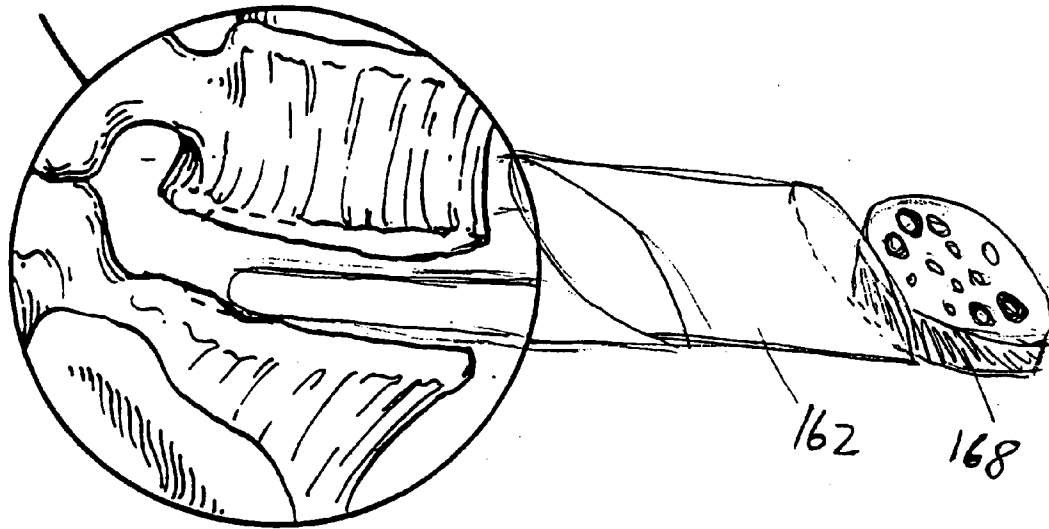
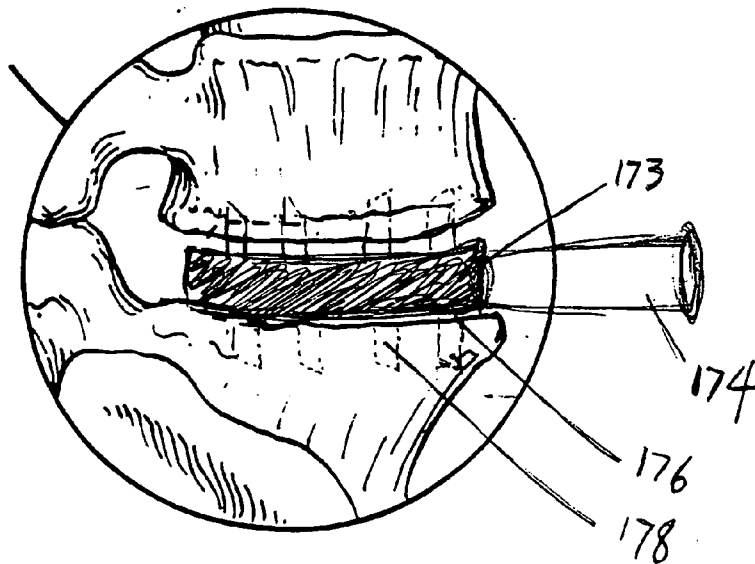

Figure 9D



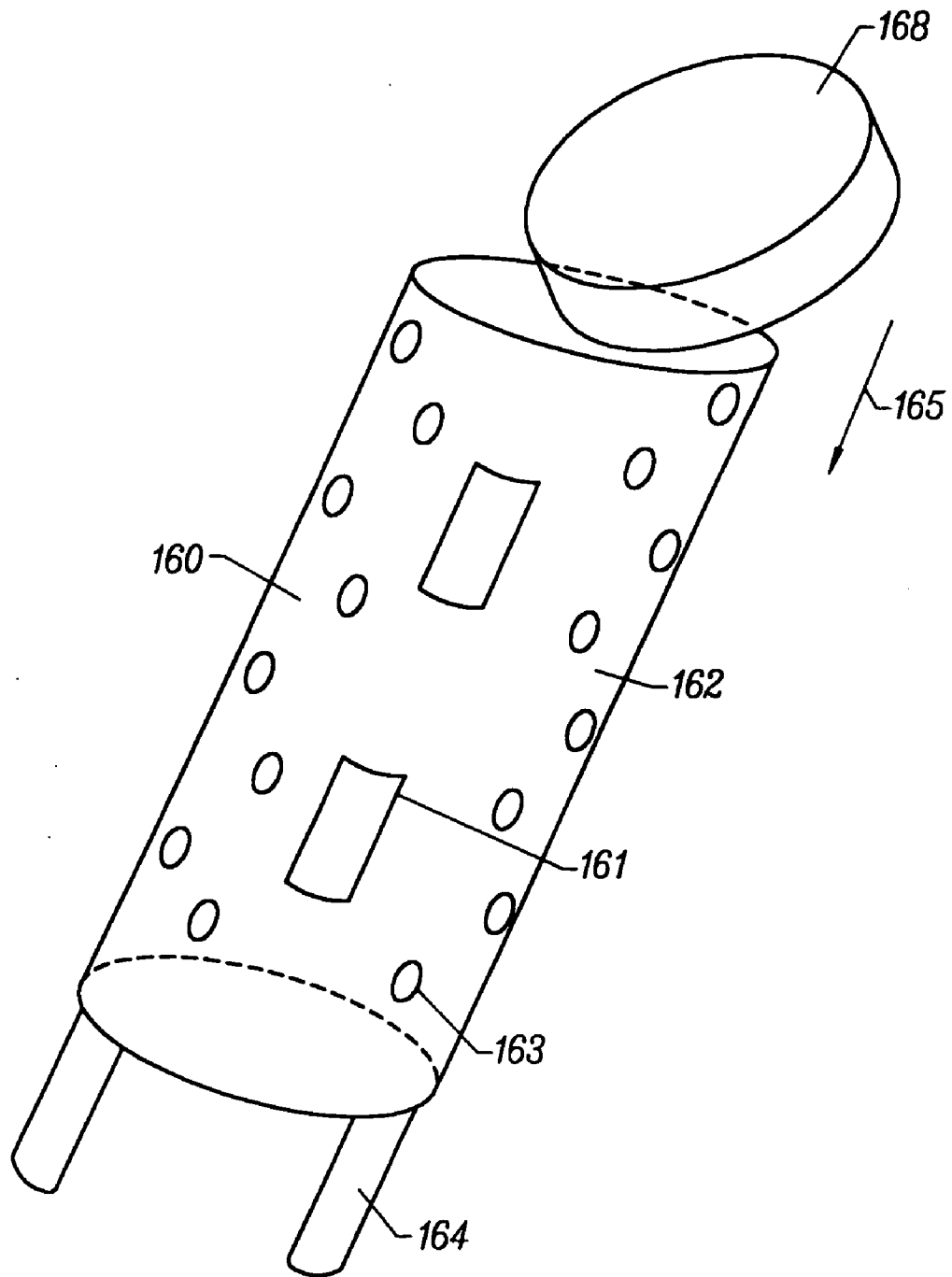

FIG. 10

METHOD AND APPARATUS FOR INTERVERTEBRAL IMPLANT ANCHORAGE

FIELD OF THE INVENTION

[0001] The present invention relates to methods and devices for treating intervertebral disc diseases and more particularly to intervertebral prostheses for positioning in an intervertebral space to treat intervertebral disorders.

BACKGROUND OF THE INVENTION

[0002] Back pain remains a major public health problem, especially among aged people. Persistent and severe back pain often causes debility and disability, and such a pain is closely associated with intervertebral disc abnormalities of the spine.

[0003] The human spine is a flexible structure comprised of thirty-three vertebrae. Intervertebral discs separate and cushion adjacent vertebrae, and act as shock absorbers and allow bending between the vertebrae. An intervertebral disc comprises two major components: the nucleus pulposus and the annulus fibrosis. The nucleus pulposus is centrally located in the disc and occupies 25-40% of the disc's total cross-sectional area. The annulus fibrosis surrounds the nucleus pulposus and resist torsional and bending force applied to the disc. Vertebral end-plates separate the disc from the vertebra on either side of the disc.

[0004] Because of exertion, injury, illness, accident or abuse, one or more of the vertebrae and/or one or more discs may become damaged and malfunctioning. Specifically, disorders of the vertebrae and discs include but are not limited to 1) disruption of the disc annulus such as annular fissures; 2) chronic inflammation of the disc; 3) localized disc herniations with contained or escaped extrusions; and 4) relative instability of the vertebrae surrounding the disc.

[0005] Various approaches have been developed to treat back pain. Minor back pain can be treated with medication and other non-invasive therapy. However, it is often necessary to remove at least a portion of the damaged and/or malfunctioning back component. For example, when a disc becomes ruptured, the ruptured disc may be surgically removed and the two vertebrae between the removed disc fuse together. In one approach, the end plates of two adjacent vertebra are fused posterior-laterally by screws. However, such posterior fusion with rigid end-plate fusion can be associated with pseudoarthrosis.

[0006] To promote fusion or arthrodesis across the intradiscal space, intervertebral implants are used to support and fuse together adjacent vertebrae by posterior-fusion or anterior grafting. For example, surgical—prosthetic implant for vertebrae described in U.S. Pat. No. 5,827,328 include rigid annular plugs that have ridged faces to engage adjacent vertebrae to resist displacement and allow ingrowth of blood capillaries and packing of bone graft. These annular implants are usually made of biocompatible carbon fiber reinforced polymers, or traditional orthopaedic implant materials such as nickel, chromium, cobalt, stainless steel or titanium. The individual implants are internally grooved and are stacked against each other to form a unit between the two adjacent vertebrae. One of the disadvantages of these interlocked implants is that, the implants may not be stable enough to withstand rotation and may lead to implant loosening and failure of the prosthesis.

[0007] Another intervertebral fusion device described by Kozak, et al. (U.S. Pat. No. 5,397,364) includes an assembly of two lateral spacers and two central spacers, which defines a channel in the center of the fusion device for insertion of the bone graft material. The spacers are maintained in their configuration within the intradiscal space by screws threaded into a vertebra from the outside of the disc. A disadvantage of this device is a tendency for the anchoring screws to become dislodged.

SUMMARY OF THE INVENTION

[0008] An anchoring plate is provided for anchoring an intradiscal device to an end plate of a vertebra. The anchoring plate includes a plate member sized to be positioned within an intradiscal section between adjacent vertebrae and a plurality of anchoring elements extending from a surface of the plate member, each anchoring element including a distal portion capable of being introduced into the vertebra through the vertebral end plate. In one embodiment, at least one of the anchoring elements includes a lumen. The lumen allows ingrowth of the bone graft material through the lumen to the end-plate of the vertebra. The lumen preferably has a diameter between about 0.5 mm-9 mm.

[0009] An implantable device for insertion into an intradiscal section between adjacent vertebrae is also provided which includes an anchor plate comprising of a plate member sized to be positioned within an intradiscal section between adjacent vertebrae and a plurality of anchoring elements extending from a surface of the plate member, each anchoring element including a distal portion capable of being introduced into an end plate of one of the adjacent vertebrae; and an intradiscal component coupled to the anchor plate. In one embodiment, the intradiscal component includes a spacer separating the anchor plate from the end plate of the other adjacent vertebra. In another embodiment, the intradiscal component includes a cage having a first side for positioning adjacent a first vertebra and a second side for positioning adjacent a second vertebra, the first side including a plurality of holes through which the anchoring elements on the anchor plate can be positioned, and the second side including at least one hollow bore for ingrowth of bone material. In yet another embodiment, the intradiscal component includes an artificial disc.

[0010] Another implantable device for insertion into an intradiscal section between adjacent vertebrae is provided which includes a first anchor plate comprising a plate member sized to be positioned within an intradiscal section adjacent a first vertebrae and a plurality of anchoring elements extending from a surface of the plate member, each anchoring element including a distal portion capable of being introduced into an end plate of the first vertebra; a second anchor plate comprising a plate member sized to be positioned within an intradiscal section adjacent a second vertebrae and a plurality of anchoring elements extending from a surface of the plate member, each anchoring element including a distal portion capable of being introduced into an end plate of the second vertebra; and an intradiscal component coupled to the first and second anchor plates. In one embodiment, the intradiscal component includes a spacer separating the first anchor plate from the second anchor plate. In another embodiment, the intradiscal component includes a cage having a first side for positioning adjacent the first vertebra and a second side for positioning adjacent

the second vertebra, the first and second sides each including a plurality of holes through which the anchoring elements on the first and second anchor plates can be positioned. In yet another embodiment, the intradiscal component includes an artificial disc.

[0011] A method is also provided for anchoring an implantable device within an intradiscal section between adjacent vertebrae which includes:

[0012] creating a space between adjacent vertebrae;

[0013] inserting into the space created an intradiscal device comprising an anchor plate comprising a plate member sized to be positioned within the space and a plurality of anchoring elements extending from a surface of the plate member, each anchoring element including a distal portion capable of being introduced into an end plate of one of the adjacent vertebrae; and

[0014] causing the anchoring elements on the anchor plate to be introduced into the vertebrae through the vertebral end plate.

[0015] In one embodiment according to the method, the anchoring elements are introduced into the vertebrae by applying a force to the anchor plate, anchor plate having a vector positioned entirely within the intradiscal space. In one variation, the force is applied to the anchor plate approximately perpendicular to a plane of the end plate,

[0016] In another embodiment, the anchoring elements are introduced into the vertebrae without rotating the anchor elements.

[0017] In yet another embodiment, the anchoring elements are introduced into the vertebrae without first creating one or more holes in the vertebrae for the anchoring elements.

[0018] In yet another embodiment, the implantable device includes an intradiscal component. Examples of intradiscal components include an—intradiscal spacer, a cage, and an artificial disc.

[0019] In yet another embodiment, the implantable device includes first and second anchor plates, inserting including positioning the first anchor plate adjacent a first of the adjacent vertebra and positioning the second anchor plate adjacent a second of the adjacent vertebra, and causing including causing anchoring elements on the first anchor plate to be introduced into the first vertebra and causing anchoring elements on the second anchor plate to be introduced into the second vertebra.

[0020] In the apparatuses and methods of the present invention, the plate member preferably has a non-smooth surface so as to promote ingrowth of bone material on the surface. The plate member also preferably has at least one hollow bore through the plate to allow ingrowth of bone material through the plate to the end plate of the vertebra.

[0021] The anchoring elements can have a plurality of shapes including cone, cylinder, triangle, square, rectangle and other irregular shapes so long as the anchoring elements are capable of being introduced into an end plate of a vertebra. The anchoring elements can extend from the plate member substantially vertically, angularly or curved. The anchoring elements are preferably shaped so as to minimize

the risk of splintering the vertebra by introducing the anchoring elements into the vertebra.

[0022] The apparatuses and methods of the present invention may be used for a variety of medical procedures in spine surgery. For example, the anchor plate may be used to secure an implant inserted between adjacent vertebrae, the implant including bone grafts, artificial annular plugs, compressible fusion material, artificial intravertebral disc or other prosthetic devices. The implantable device may be used to replace the damaged and/or malfunctioning intravertebral disc with an artificial disc attached to the anchor plate on the device, or to replace the whole vertebral body with an artificial vertebra which is biomechanically compatible to the spine. The implantable device can be customized to the individuals being treated. In one embodiment, the anchor plate has substantially the shape of a naturally-occurring intervertebral disc and the size of the patient's disc.

[0023] Additional advantages of the present invention are set forth in the description which follows.

BRIEF DESCRIPTION OF THE DRAWINGS

[0024] FIG. 1 illustrates an implantable device according to the present invention.

[0025] FIG. 2 illustrates two hemi-implantable devices.

[0026] FIG. 3A illustrates an implantable device having anchoring elements extending from one side of the device.

[0027] FIG. 3B illustrates an implantable device having anchoring elements extending from opposing sides of the device.

[0028] FIG. 4 illustrates an embodiment of an anchor plate

[0029] FIGS. 5A-D illustrate an implantable device having a cage.

[0030] FIG. 5A is a side view of the implantable device

[0031] FIG. 5B is a sagittal view the implantable device.

[0032] FIG. 5C is a sagittal view of an anchor plate of the implantable device.

[0033] FIG. 5D is a sagittal view of a spacer inside of the implantable device.

[0034] FIG. 5E illustrates a disassembled implantable device with opposing anchor plates and sidewalls for maintaining a separation between the anchor plates.

[0035] FIG. 5F illustrates side view of an assembled implantable device with opposing anchor plates and sidewalls for maintaining a separation between the anchor plates.

[0036] FIG. 5G illustrates another side view of an assembled implantable device with opposing anchor plates and sidewalls for maintaining a separation between the anchor plates.

[0037] FIG. 6 illustrates an implantable device containing an artificial intervertebral disc.

[0038] FIGS. 7 A-E illustrate assembly of an implantable device.

[0039] FIG. 7A is a frontal view of the assembly of an implantable device.

[0040] FIG. 7B is a side view of the assembly of an implantable device.

[0041] FIG. 7C illustrates the assembled implantable device.

[0042] FIG. 7D is a rear view of the assembled implantable device.

[0043] FIG. 7E is a side view of the assembled implantable device.

[0044] FIG. 7F illustrates assembly of the implantable device illustrated in FIGS. 5A-D.

[0045] FIG. 8A illustrates an implantable device of FIG. 7A-E inserted in an intradiscal space prior to extension of anchoring elements.

[0046] FIG. 8B illustrates the implantable device of FIG. 7A-E where the anchoring elements have been extended into the end plates of adjacent vertebrae.

[0047] FIGS. 9A-D illustrate a method for implanting an implantable device according to the present invention.

[0048] FIG. 9A illustrates inserting a spacer between two adjacent vertebrae.

[0049] FIG. 9B illustrates putting a guide over the spacer.

[0050] FIG. 9C illustrates inserting an implantable device into the guide.

[0051] FIG. 9D illustrates using a wedge spreader to introduce anchoring elements into the end plate of the vertebra.

[0052] FIG. 10 illustrates an example of a guide used in the method described in FIGS. 9A-D.

DETAILED DESCRIPTION OF THE PREFERRED EMBODIMENT

[0053] The present invention relates to devices which may be anchored to vertebrae of the spine by introducing anchoring elements through an end plate of the vertebrae. In particular, an anchoring plate, which comprises a plurality of anchoring elements such as spikes or prongs extending from the plate, is provided for anchoring an intradiscal device to an end plate of a vertebra. By securing the anchor plate to an end plate of the vertebra, a surgeon operating on a patient's spine can attach a variety of intradiscal components to the anchor plates. The secured anchorage and support provided by the apparatus of the present invention prevents loosening of the apparatus and enhances the fusion of the adjacent vertebrae.

[0054] A variety of intradiscal components can be incorporated into the apparatus of the present invention. In one embodiment, the intradiscal component includes a cage within which the anchor plate is contained. Bone graft material can be filled into the cage which is attached to and stabilized by the anchor plate on an end plate of a vertebra, thereby promoting bone ingrowth through the holes on the cage. Alternatively, an artificial intravertebral disc can be included in the apparatus.

[0055] It should be noted that other intervertebral fusion devices may also be attached to the anchor plate for restoring or maintaining the normal geometry of the intradiscal space, such as disc height and sagittal angle. Moreover, an artificial vertebral body which is biomechanically compatible with the spine may be attached to the anchor plate to replace a damaged vertebra and restore normal functions to the spine.

[0056] One embodiment of the invention is illustrated in FIG. 1, showing a frontal view of an implantable device 10 inserted between two adjacent vertebrae L4 and L5. In this embodiment, the implantable device 10 includes a first anchor plate 12, a second anchor plate 14 and an intradiscal component 16. Each of the first and second anchor plates includes a plate member 18 and a plurality of anchoring elements 20 extending from a surface 11 of the plate member 18. The anchoring elements 20 on each of the anchor plates 12 and 14 are introduced into vertebrae L4 and L5 through end plates E4 and E5 of vertebrae L4 and L5, respectively. This embodiment of the implantable device has a size approximating the intradiscal space between adjacent vertebrae. This device is particularly suitable for positioning via an anterior approach. Because intervertebral discs are located in front of the spine and anterior to the spinal cord 15, prosthetic operations such as disc replacement through an anterior approach eliminates the need to remove or retract nerve, thus reducing the risk of nerve injury.

[0057] Alternatively, the implantable device according to the present invention may also be sized to a hemicycle or hemioval. As illustrated in FIG. 2, two hemioval implantable devices 30 and 32 can be used to approximate the intradiscal space and conform with the general outline perimeter of the vertebrae. Such an implantable device with a hemioval size allows better access to the posterior portion of the spine when the devices are implanted through a posterior approach. For example, the first hemi-device 30 can be inserted into and fill in half of the intradiscal space without colliding with the spinal core 15, then followed by placing the second hemi-implantable device 32 to fill in the other half of the intradiscal space. Similar to the implantable device 10 illustrated in FIG. 1, the anchoring elements on the hemi-implantable device are introduced into the end plate E4 and E5 of the vertebrae L4 and L5, respectively. Bone graft material or artificial disc can be put into the device for posterior-lateral fusion or rigid posterior instrumentation. Positioning the bone graft material between first and second anchor plates 12, 14 to attain fusion and prevent the anchor plates from being dislodged from the vertebrae.

[0058] In another embodiment, as illustrated in FIG. 3A, the implantable device 40 includes an anchor plate 42 and an intradiscal component 44. The anchor plate 42 includes a plate member 46 and a plurality of anchoring elements 48 extending from the plate member 46. The anchoring elements 48 can be introduced into an end plate of a vertebra by applying a force in a direction 45 approximately perpendicular to the end plate, thereby securing the device 40 within an intradiscal space. In this regard, the force applied to the anchoring elements may have a vector positioned entirely within the intradiscal space.

[0059] In yet another embodiment, as illustrated in FIG. 3B, an implantable device 50 includes a first anchor plate 52, a second anchor plate 54 and an intradiscal component 56. Each of the first and second anchor plates 52 and 54 includes

a plate member **58** and a plurality of anchoring elements **60** extending from the plate member **58**. The anchoring elements **60** on anchor plate **52** can be introduced into an end plate of a vertebra in directions **55**, **57** approximately perpendicular to the end plates, thereby securing the device **50** within an intradiscal space between the two adjacent vertebrae.

[**0060**] An illustration of an embodiment of an anchor plate is illustrated in **FIG. 4**. In this embodiment, the anchor plate **70** includes a plate member **72** and a plurality of anchoring elements **74** extending from a surface **71** of the plate member **72**. It is preferred that a plate member **72** has at least one hollow bore or hole **75** through surface **71** and **73** of the plate member **72** to allow bone ingrowth through the hole **75** to the end plate **E4** of vertebra **L4**, thereby enhancing fusion of adjacent vertebrae. The hole **75** may be positioned such that the hole is adjacent-nucleus pulposus **N4** of the operative intravertebral disc when the device is positioned intervertebrally. The hole is preferably smaller than and optionally as large as the nucleus pulposus **N4**. This positioning and sizing of the hole **75** allows fusion of bone graft material with a weaker portion of the vertebra known to be highly vascular and biological active.

[**0061**] The anchor plate **70** includes at least two anchoring elements **74** distributed on the surface **71** of the plate member **72**. The anchor plate may have any regular shape: round, square, rectangle, elliptical, or an irregular shape. The anchor plate is preferred to have a surface area between about 5 mm²-40 mm²; and a thickness preferably between about 1 mm-10 mm, more preferably about 5 mm.

[**0062**] The anchoring elements **74** are preferred to be sharp spikes having a cone, cylinder, square or rectangle shape. The height and width of the anchoring elements are preferably between about 0.5 mm-15 mm, 0.3 mm-15 mm, respectively.

[**0063**] In a preferred embodiment, the anchoring element **74** includes a lumen **80**. The lumen preferably has a diameter between about 0.5 mm-9 mm. The lumen allows ingrowth of the bone graft material through the lumen to the end-plate of the vertebra. The lumen also facilitates entry of the anchoring element into the end plate without splintering the vertebra. The surface of the lumen is preferably rough.

[**0064**] The distal portion **77** of the anchoring element **74** may be straight or curved. The surface **79** of the anchoring element **74** is preferred to have a smooth outer surface to facilitate penetration of the element **74** into the end plate **E4**. In particular, the surface **79** of the anchoring element **74** is preferred not to have a thread for screwing the element **74** into the end plate **E4**.

[**0065**] The anchoring elements **74** may extend from the plate member **11** substantially vertically, angularly or curved. The direction of the force used to cause the anchoring elements to enter the vertebra will depend—on the shape and angular positioning of the anchoring elements.

[**0066**] The materials used to construct the anchor plate and the implantable device are preferred to be able to endure the stresses and environment to which a vertebra implant is subjected. In addition, such materials should be biocompatible, and substantially chemically inert so as not to cause any detrimental effect to the patient in whom the device is implanted. The anchor plate and implantable device may be made of radiolucent material such as carbon fiber reinforced polymers known commercially as “Peek[∞] (polyetherether

ketone) or “Ultrapak” (polyether ketone, ether ketone, ketone), polycarbonate, polypropylene, polyethylene and polysulfone plastics material filled with glass or carbon fibers, or traditional orthopaedic implant material such as nickel stainless steel, titanium alloy, heavy plastic polymer, ceramic, etc. One of ordinary skill in the art will recognize other suitable materials, for example, a cobalt-chromium alloy or a titanium alloy having 4% vanadium and % aluminum, ceramic material such as aluminium oxide and zirconium oxide. The surface **71** of the anchor plate **70** is preferred to be rough to potentiate bone ingrowth on the side of the plate contacting the end plate **E4** of the vertebra **L4**, thereby strengthening the anchorage to the end plate. The surface **73** of the anchor plate **70** may be porous coated or coated with hydroxyapatite or bioactive proteins (e.g. bone morphogenic protein) to promote bone ingrowth.

[**0067**] **FIGS. 5A-D** illustrate a preferred embodiment of an implantable device. As illustrated in **FIG. 5A**, the implantable device **100** includes an intradiscal component - - a cage **102**, a first anchor plate **104** and a second anchor plate **106** contained within the cage **102**. A plurality of anchoring elements **108** on each of the anchor plates **104** and **106** extend from the anchor plates and through holes **115** on the surfaces **111** and **113**, respectively of the cage **102**. The cage **102** includes intervertebral lateral channels **105** and frontal channels **107** which are adapted to receive bone graft material therein. In addition, channel **109** is configured to receive a screw therethrough for causing the anchoring elements **108** to be pushed into the end plates of adjacent vertebrae.

[**0068**] **FIG. 5B** is a sagittal view of the implantable device **100**. The surface **111** of cage **102** contacts an end plate of a vertebra and is preferred to be porous and coated with hydroxyapatite or bone morphogenic protein to promote bone ingrowth. As illustrated, anchoring elements **108** with lumen **101** extend through holes **115** in the cage **102**.

[**0069**] **FIG. 5C** illustrates the first anchor plate **104** included in the implantable device **100**. A plurality of anchoring elements **108** extend substantially vertically from a plate member **112**. The anchor plate **104** have hollow bores **117** to form part of channel **103** and recessed portion configured to be accommodated within the cage **102** and to receive force applied to introduce the anchoring elements **108** into the end plates of adjacent vertebrae.

[**0070**] **FIG. 5D** illustrates a spacer **116** included in the cage of the implantable device **100**. The hollow bores **119** form part of the channels **103**, **105**, **107** and **109**.

[**0071**] **FIGS. 5E-G** illustrate an alternate embodiment of an implantable device with opposing anchor plates and sidewalls for maintaining a separation between the anchor plates. **FIG. 5E** illustrates the device disassembled with two opposing anchor plates **104**, **106** and two sidewall support members **129A** and **129B**. The sidewall support members each include recessed grooves **131** for attaching the sidewall support members to the anchor plates.

[**0072**] **FIGS. 5F and 5G** illustrate side views of the device illustrated in **FIG. 5E** once assembled. Assembly is achieved by attaching each sidewall support member to a side of the anchor plates. The device illustrated in **FIGS. 5E-G** have an advantage of being smaller than the devices illustrated in **FIGS. 5A-5D** since the sidewall spacers remove—the need for the cage.

[**0073**] **FIG. 6** illustrates an embodiment of an artificial disc **120**. As illustrated in **FIG. 6**, oval-shaped nucleus **121**

made of ceramic or stainless steel is housed inside of the cage 122. Anchoring elements 128 extend from the anchor plates 124 and 126 and can be introduced into the end plates of adjacent vertebrae, thereby replacing the damaged and/or malfunctioning disc with an artificial one.

[0074] Details of the assembly of an embodiment of an implantable device are illustrated in FIGS. 7A-C. According to this embodiment, the implantable device 130 includes a first anchor plate 132, a second anchor plate 134, and a cage comprising an upper cover 138 and a bottom plate 140 (FIG. 7A). The first and second anchor plates 132 and 134 are adapted to fit into the cage with a portion of the plates flanked by two supporting members 146. The anchoring elements 142 on the anchor plate are positioned through the hole 141 on the upper cover 138 and bottom plate 140. As illustrated in FIG. 7B showing a side view of the assembly, a wedge 144 is inserted between the upper cover 138 and bottom plate 140 of the cage 136. Through a channel formed by holes 145 and 147, a fixation screw 146 can be used to drive the wedge 144 which pushes the anchor plates 132 and 134 toward end plates of adjacent vertebrae, thereby introducing the anchoring elements 142 into the end plates and securing the device 130 intradiscally. Further, as illustrated in FIG. 7C showing the assembled implantable device 130, there are also a plurality of holes 143 throughout the anchor plates, the upper cover 138 and the bottom plate 140 to allow bone ingrowth through the device 130 to enhance intervertebral fusion.

[0075] FIG. 7F illustrates assembly of the implantable device illustrated in FIGS. 5A-D.

[0076] A method is also provided for anchoring an implantable device within an intradiscal section between adjacent vertebrae which includes:

[0077] creating a space between adjacent vertebrae;

[0078] inserting into the space created an implantable device comprising an anchor plate comprising of a plate member sized to be positioned within the space and a plurality of anchoring elements extending from a surface of the plate member, each anchoring element including a distal portion capable of being introduced into an end plate of one of the adjacent vertebrae; and

[0079] causing the anchoring elements on the anchor plate to be introduced into the vertebrae through the vertebral end plate.

[0080] Another method is provided for anchoring an implantable device within an intradiscal section between adjacent vertebrae which includes:

[0081] creating a space between adjacent vertebrae;

[0082] inserting into the space created an implantable device comprising

[0083] a first anchor plate comprising of a plate member sized to be positioned within the space and a plurality of anchoring elements extending from a surface of the plate member, each anchoring element including a distal portion capable of being introduced into an end plate of one of the adjacent vertebrae;

[0084] a second anchor plate comprising of a plate member sized to be positioned within the space and a plurality of anchoring elements extending from a surface of the plate member, each anchoring element

including a distal portion capable of being introduced into an end plate of one of the adjacent vertebrae; and

[0085] causing the anchoring elements on the first and second anchor plates to be introduced into the vertebrae through the vertebral end plate.

[0086] As illustrated in FIG. 8A, the anchoring elements 142 of first (132) and second (134) anchor plates of an implantable device 130 illustrated in FIGS. 7A-E are introduced into the vertebrae by applying a force with fixation screws 146 to the anchor plates approximately perpendicular to a plane of the end plate such as E4 and E5 of vertebrae L4 and L5, respectively. FIG. 8B shows that the implantable device 130 is anchored between the adjacent vertebrae L4 and L5 by the anchoring elements 142 penetrating vertebral end plates E4 and E5.

[0087] As also illustrated in FIGS. 8A and 8B, the anchoring elements 142 are introduced into the vertebrae L4 and L5 without rotating the anchor elements 142. Screwing an element into a vertebra can cause the vertebra to splinter.

[0088] As also illustrated in FIGS. 8A and 8B, the anchoring elements are introduced into the vertebrae without first creating one or more holes in the vertebrae for the anchoring elements.

[0089] In yet another embodiment according to the method, the implantable device includes an intradiscal component. Examples of intradiscal components include an intradiscal spacer, a cage, and an artificial disc.

[0090] In yet another embodiment according to the method, the implantable device includes first and second anchor plates, inserting including positioning the first anchor plate adjacent a first of the adjacent vertebra and positioning the second anchor plate adjacent a second of the adjacent vertebra, and causing including causing anchoring elements on the first anchor plate to be introduced into the first vertebra and causing anchoring elements on the second anchor plate to be introduced into the second vertebra.

[0091] FIGS. 9A-9C illustrate a method for introducing a device according to the present invention by an anterior approach. FIG. 10 illustrates a guide employed in the method.

[0092] As illustrated in FIG. 10, a guide 160 includes a sleeve 162 and at least two lips 164 that can be inserted intradiscally to maintain the height of the disc space. The sleeve 162 is preferably cylindrical with an elliptical cross section 167, and has multiple vents 161 and 163 for proper circulation of air. A replacement disc 168 can be introduced into the intradiscal space through the sleeve 162 in a direction 165 approximately along a longitudinal axis of the sleeve.

[0093] FIGS. 9A-D illustrate a method for implanting a device via anterior approach. As illustrated in FIG. 9A, an intervertebral disc 180 to be replaced is accessed through a laparoscopic anterior approach. The disc 180 is exposed anteriorly, i.e. beneath the chest and abdomen of the patient. After the disc 180 to be removed has been identified, the disc is surgically removed. To prepare the adjacent vertebrae to receive the disc replacement 168, cartilage on the end plates of the adjacent vertebrae is removed by an instrument 181 following known procedures. Care should be taken not to violate the end plates. One or two spacers 172 are then inserted into the intradiscal space, with the adjacent vertebrae being separately distracted by a wedge so as to allow

proper location of the spacer **172**. The spacer **172** also serves as a measurement of the height of the disc space.

[0094] As illustrated in **FIG. 9B**, a guide **160** (described in regard to **FIG. 10**) is put over the spacers **172** with the lips **164** of the sleeve **162** replacing the spacers **172**. The spacers **172** are then removed from the disc space. As illustrated in **FIG. 9C**, once the disc replacement guide sleeve **160** is properly positioned, an implantable device such as a replacement disc **168**, is inserted through the sleeve **162** into the interdiscal space. As illustrated in **FIG. 9D**, a wedge spreader **174** is then inserted into a channel **173** defined by the implantable device to distract the anchor plates **176** and introduce anchoring elements **178** on the anchor plates **176** into the end plates of the adjacent vertebrae.

[0095] While the present invention is disclosed by reference to the various embodiments and examples detailed above, it should be understood that these examples are intended in an illustrative rather than limiting sense, as it is contemplated that modifications will readily occur to those skilled in the art which are intended to fall within the scope of the present invention.

1-40. (Canceled)

41. A method of implanting an intervertebral device, comprising:

accessing an implantation site:

attaching a first anchor plate to an end plate of a first vertebrae:

attaching a second anchor plate to an end plate of a second vertebrae; and

detachably securing an intervertebral device to the implanted first and second anchor plates.

42. The method of claim 41 further comprising accessing the implantation site via an anterior approach.

43. A method claim 42 further comprising:

anteriorly exposing the implantation site:

identifying a vertebrae to be removed from the implantation site:

surgically removing the vertebrae to be removed: and

preparing the end plates of the first and second vertebrae to receive the intervertebral device.

44. A method of implanting an intervertebral device, comprising:

accessing an implantation site:

removing a dysfunctional vertebrae:

attaching a first anchor plate to an end plate of a first vertebrae:

attaching a second anchor plate to an end plate of a second vertebrae, and

detachably securing an intervertebral device to the implanted first and second anchor plates.

45. The method of claim 44 further comprising anteriorly accessing the implantation site.

* * * * *