



(51) International Patent Classification:

A41B 9/14 (2006.01) A61F 13/70 (2006.01)
A61F 5/457 (2006.01) A61F 13/505 (2006.01)

(21) International Application Number:

PCT/SE201 1/051495

(22) International Filing Date:

9 December 2011 (09.12.201 1)

(25) Filing Language:

English

(26) Publication Language:

English

(71) Applicant (for all designated States except US): SCA HYGIENE PRODUCTS AB [SE/SE]; S-405 03 Goteborg (SE).

(72) Inventors; and

(75) Inventors/Applicants (for US only): HANSSON, Roy [SE/SE]; Prytzgatan 39, S-431 31 Molndal (SE). SVENSSON, Niclas [SE/SE]; St Jorgens Alle 3, S-422 49 Goteborg (SE).

(74) Agent: ALBIHNS.ZACCO AB; Box 142, S-401 22 Goteborg (SE).

(81) Designated States (unless otherwise indicated, for every kind of national protection available): AE, AG, AL, AM, AO, AT, AU, AZ, BA, BB, BG, BH, BR, BW, BY, BZ, CA, CH, CL, CN, CO, CR, CU, CZ, DE, DK, DM, DO, DZ, EC, EE, EG, ES, FI, GB, GD, GE, GH, GM, GT, HN, HR, HU, ID, IL, IN, IS, JP, KE, KG, KM, KN, KP, KR, KZ, LA, LC, LK, LR, LS, LT, LU, LY, MA, MD, ME, MG, MK, MN, MW, MX, MY, MZ, NA, NG, NI, NO, NZ, OM, PE, PG, PH, PL, PT, QA, RO, RS, RU, RW, SC, SD, SE, SG, SK, SL, SM, ST, SV, SY, TH, TJ, TM, TN, TR, TT, TZ, UA, UG, US, UZ, VC, VN, ZA, ZM, ZW.

(84) Designated States (unless otherwise indicated, for every kind of regional protection available): ARIPO (BW, GH, GM, KE, LR, LS, MW, MZ, NA, RW, SD, SL, SZ, TZ, UG, ZM, ZW), Eurasian (AM, AZ, BY, KG, KZ, MD, RU, TJ, TM), European (AL, AT, BE, BG, CH, CY, CZ, DE, DK, EE, ES, FI, FR, GB, GR, HR, HU, IE, IS, IT, LT, LU, LV, MC, MK, MT, NL, NO, PL, PT, RO, RS, SE, SI, SK,

[Continued on nextpage]

(54) Title: GARMENT COMPRISING CHASSIS AND BELT

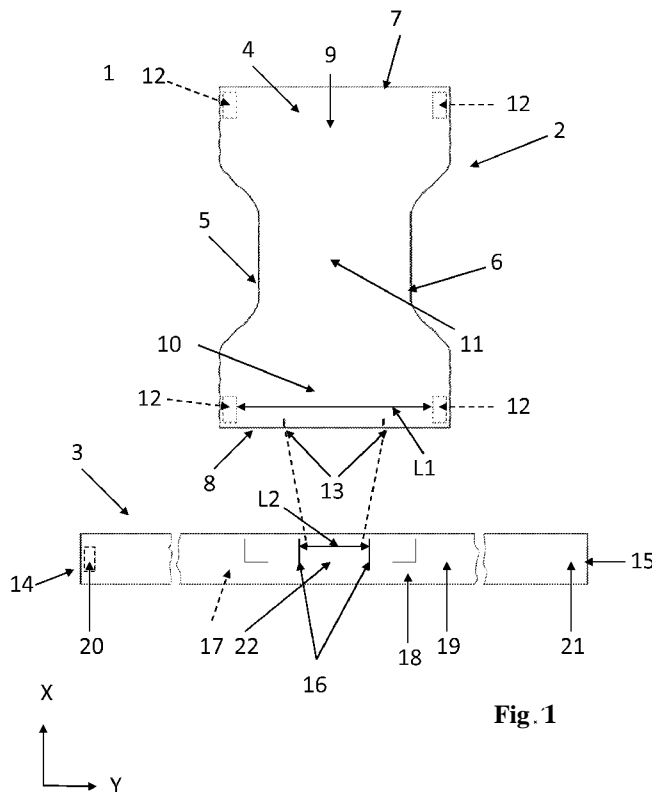
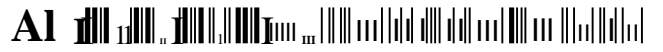

Fig. 1

(57) Abstract: The present invention relates to an article (1) comprising a chassis (2) and a belt (3). The belt (3) is separable from the chassis (2) and is arranged to be placed around the waist of a wearer. The belt (3) comprises first elastic means (22) for allowing stretching of the belt (3) during use in a lateral direction. The chassis (2) comprises at least a first layer (4) of a conformable material for the user. The chassis (2) comprises longitudinal sides (5, 6) and lateral sides (7, 8) and is divided into a front portion (9), a rear portion (10) and a crotch portion (11) located between the front portion (9) and the rear portion (10) in a longitudinal direction. The front portion (9) and/or the rear portion (10) of the chassis (2) comprises a pair of first fastening means (12) being separate with a first distance (L1). The chassis (2) is arranged to be detachably attached to the outer surface (18) of the belt (3) by means of said first fastening means (12). Said outer surface (18) comprises second fastening means (19) arranged to be detachably attached to the first fastening means (12). The chassis (2) comprises a pair of first stretch markings (13) being related to the first distance (L1). The belt (3) comprises a pair of second stretch markings (16) marking out a second distance (L2) when the belt (3) is in a relaxed state and a predetermined third distance (L3) when the belt (3) is in a stretched state. The first stretch markings (13) are intended, in the relaxed state, to be positioned in conjunction with the second stretch markings (16) or within the second distance (L2) for allowing the chassis (2) to be attached to the belt (3) in the relaxed state via the first fastening means (12) and allowing the belt (3) to be stretched into the third distance (L3) without jeopardizing the fastening of the first fastening means (12).

WO2013/085445 A1

w o 2013/085445



SM, TR), OAPI (BF, BJ, CF, CG, CI, CM, GA, GN, GQ, GW, ML, MR, NE, SN, TD, TG). **Published:**

— *with international search report (Art. 21(3))*

Garment comprising chassis and belt

Technical Field

5 The invention relates to an article comprising a chassis and a belt. The belt can be separated from the chassis and arranged to be placed around the waist of a wearer. The belt comprises an inner surface facing the user during use and an outer surface facing away from the user during use. The belt comprises first elastic means for allowing stretching of the belt during use in a lateral direction. The chassis comprises at least a first layer of a conformable
10 material for the user. The chassis comprises longitudinal sides and lateral sides and is divided into a front portion, a rear portion and a crotch portion located between the front portion and the rear portion in a longitudinal direction. The front portion and/or the rear portion of the chassis comprises a pair of first fastening means being separated by a first distance. The chassis is arranged to be detachably attached to the outer surface of the belt
15 by means of said first fastening means. The outer surface comprises second fastening means arranged to be detachably attached to the first fastening means.

Background Art

Articles in the shape of pants are known from many examples in the art. Some of these
20 articles are provided with a belt arranged to be placed around the waist of a wearer in order to facilitate putting the article on or off. Some articles have a belt that is integrated with a chassis, where the belt is discarded together with the chassis. Alternatively the belt may form a separate part detachably attached to the chassis. See US 5971970 and US 5906604 for prior art articles.

25

In the case of a detachable belt the belt is provided with attaching elements, which are attached to each other when the belt is placed around the waist of the wearer in use. To put the chassis on the wearer attaches one of the ends of the chassis to the belt. The free end of the chassis is then passed through between the legs of the wearer and attached to the
30 belt.

A problem with existing articles is that there is a risk that the chassis will detach from the belt if the belt is elongated more than the maximum possible elongation of the material between the attachment elements of the chassis. By attaching the chassis to the belt and thereafter
35 stretching the belt there is a possibility that the elongation of the elastics in the chassis will reach a maximum limit before the elastics of the belt reaches its maximum elongation. The result may then be that the attaching elements may separate from the belt is elongated

further due to stress from the elongation of the belt. This may result in the article becoming misplaced on the user thereby resulting in reduced functionality of the article or that the chassis simply falls off. In the case where the article is an absorbent article this may lead to unwanted soiling of garments and similar.

5

Summary of Invention

In view of prior art there is a need for an improved article that remedies the above mentioned problems.

10 The object of the present invention is to provide an article that overcomes the issue of a chassis that involuntarily detaches from a belt. This object is achieved by the characterizing portion of claim 1.

The present invention relates to an article comprising a chassis and a belt. The belt is
15 separate from the chassis and is arranged to be placed around the waist of a wearer. The belt comprises an inner surface facing the user during use and an outer surface facing away from the user during use. The belt comprises first elastic means for allowing stretching of the belt during use in a lateral direction. The chassis comprises at least a first layer of a conformable material for the user. The chassis comprises longitudinal sides and lateral sides
20 and is divided into a front portion, a rear portion and a crotch portion located between the front portion and the rear portion in a longitudinal direction. The front portion or the rear portion of the chassis comprises a pair of first fastening means being separate with a first distance. The chassis is arranged to be detachably attached to the outer surface of the belt by means of said first fastening means. Said outer surface comprises second fastening
25 means arranged to be detachably attached to the first fastening means. The chassis comprises a pair of first stretch markings being related to the first distance. The belt comprises a pair of second stretch markings marking out a second distance when the belt is in a relaxed state and a predetermined third distance when the belt is in a stretched state. The first stretch markings are intended, in the relaxed state, to be positioned in conjunction
30 with the second stretch markings or within the second distance for allowing the chassis to be attached to the belt in the relaxed state via the first fastening means and allowing the belt to be stretched into the third distance without jeopardizing the fastening of the first fastening means.

35 By having first stretch markings on the chassis and second stretch markings on the belt marking out when the belt is in a relaxed or a stretched state the problem of attaching the

chassis to the belt and being able to stretch the belt farther than the elastic of the chassis allows is avoided.

When attaching the chassis, which normally has none or a lower degree of elongation capacity than the belt, the user attaches the chassis so that its stretch markings are aligned with the second stretch markings or within the second distance. In the relaxed state, that part of the chassis being attached to the belt will "hang loose" in the first fastening means. Here "hang loose" means that the portion between the first fastening means is unstretched and can be folded, crumpled, hang in a curvature, or the like. The first distance is measured along the curvature or path of the chassis which means that when the belt is stretched to its maximum, corresponding to the third distance, the chassis lies flush against the belt, but in the relaxed state the distance between the first fastening means measured along the belt is less than the distance between the first fastening means when measured along the chassis.. This ensures that when the belt is stretched/elasticated partly or fully to the predetermined third distance, the loose chassis portion becomes less loose than in the relaxed state, but never so extended (non-elastic chassis) or stretched (elastic chassis) that the predetermined distance between the first fastening means is exceeded. Hence, the risk of the belt being separated from the chassis is removed or at least radically reduced.

Furthermore, this also allows for the chassis to be safely attached to the belt either when the belt is already positioned on the user, i.e. in an elongated state, or when the chassis is attached to the belt before the article is put on a user.

The first stretch markings may be positioned in conjunction with the first fastening means. However, the stretch markings may be placed anywhere on the chassis provided there is a separation between them and that they are arranged on the front and/or rear portion of the chassis and that the relationship between the stretch markings are considered for the first distance. The relationship should be such that the maximum allowable distance between the first fastening means are considered in view of the predetermined maximum stretch of the belt according to the above. During positioning of the first stretch markings onto the belt, focus may be put on the fastening means in order to ensure that they are attached properly. An advantage of having the stretch markings placed in conjunction with the first fastening means is to reduce the area of focus for the person putting the chassis into place. There is no need for the person to first ensure that the first stretch markings are in the correct place before switching to attach the first fastening means to the belt. The positioning and fastening may be done in one fluent motion.

The distance between the first stretch markings may be greater than the second distance in the relaxed state. The distance between the first stretch markings may essentially be equal to or greater than the third distance in the stretched state. A distance between the first stretch markings greater than the second distance of the belt in the relaxed state allows the caretaker or user to pre-stretch the belt up to a distance equal to the difference of the distance between the first stretch markings and the second distance prior to putting on the chassis without jeopardizing the fastening of the first fastening means. Further, having the distance between the first stretch markings equal to or greater than the third distance in the stretched state allows for an even safer way of pre-stretching the belt prior to putting on the chassis without jeopardizing the fastening of the first fastening means.

The second distance may be dependent on the stretchability of the first elastic means. Having different elastics in the belt makes it possible to vary the stretchability of the first elastic means. Having different degrees of stretchability in the belt allows the belt to be stretched to different degrees of elongation. Varying the second distance simplifies the putting on of the article in that the second distance is adapted for a pre-determined stretchability.

The chassis may comprise second elastic means, wherein the first stretch markings marks out a fourth distance when the chassis is in a predetermined maximum stretched state, wherein the fourth distance is essentially equal to or greater than the third distance in the stretched state. The chassis may comprise elastic means in order to allow the chassis to elongate as well as the belt. By having second elastic means in the chassis the chassis may more easily conform to the stretching of the belt thereby further insuring that the first fastening means stay in place. By having elastic means in the chassis the comfort of the article may also be increased as the fit of the chassis may improve.

The third distance may relate to a predetermined maximum stretch value of the belt in the stretched state.

The belt may comprise a stretch zone, wherein the distance between the outer boundaries of the stretch zone when elongated to its maximum is less than or equal to the distance between the first stretch markings in said chassis when the chassis is stretched out to its maximum.

The belt may be completely elastic or only partly elastic. The stretchability of the elastic may be such that the belt, between its second stretch markings, can be elongated less than the

chassis, between its first stretch markings, when both the belt and the chassis are maximally elongated. This would further reduce the risk of jeopardizing the fastening of the first fastening means.

- 5 The distance between the outer boundaries of the stretch zone on the belt when elongated to its maximum is less than or equal to the distance between the first stretch markings on the said chassis when the chassis is stretched out to 90 % of its maximum, preferably to 80 % of its maximum.
- 10 By allowing the second distance to never exceed more than 80-90 % of the maximum chassis elongation the chassis elastic may never reach their maximum elongation as the belt is elongated. This eliminates the risk of the chassis to be elongated beyond its maximum whereupon the first fastening means would risk de-attachment from the belt.
- 15 The stretch zone of the belt may comprise an elastic means sandwiched between two essentially non-elastic members. This is one way of constructing the belt. The belt may of course comprise more than one stretch zone.

The stretch zone on the belt comprises a coloured region. The advantage of this is to further
20 simplify the attachment of the chassis by visualising the zone where belt is elongated.

The stretch zone on the belt comprises ink added to the surface of the material which is placed away from the user's body.

- 25 The chassis is made from a washable material. This enables the reuse of the chassis thereby providing a more economical and environmentally friendly article. The belt may of course also be washable in order for the complete article to be reusable.

The chassis may comprise a top sheet, a back sheet and an absorbent core placed in-
30 between the top sheet and the back sheet.

The article may be used as an absorbent article. An absorbent package comprising an absorbent core placed between a top sheet and a back sheet may be incorporated with the chassis or may be placed as insert in the chassis. The article may also be used for other
35 purposes using other kinds of insert or be used as a kind of garment.

The first fastening means may comprise hook material and the second fastening means may comprise loop material, or vice versa.

The entire belt may be elasticated.

5

The first stretch marking on the chassis may comprise two transversal extending marks separated from each other. Other kinds of marks are of course conceivable, the chassis may also comprise a coloured region between the first stretch markings or have other kinds of marks in the shape of geometrical figures or other motifs.

10

It should be noted that the predetermined maximum stretch of the material, could refer to when the material is stretched until it is dumb.

Brief Description of Drawings

15 Figure 1 schematically shows an article comprising chassis and belt according to a first aspect of the invention,

Figure 2 schematically shows an article comprising chassis and belt according to a second aspect of the invention,

20

Figure 3 schematically shows an article comprising chassis and belt according to a third aspect of the invention,

Figure 4 schematically shows an article comprising chassis and belt according to a fourth aspect of the invention,

25

Figure 5 schematically shows a chassis according to a fifth aspect of the invention;

Figure 6 schematically shows a belt according to a sixth aspect of the invention,

30

Figure 7 schematically shows an article comprising a chassis and a belt prior to attachment of the chassis to the belt.

Detailed Description of Drawings

35 Figure 1 schematically shows an article 1 comprising a chassis 2 and a belt 3 according to a first aspect of the invention. The chassis 1 in figure 1 is seen from the side facing away from a wearer. The chassis 2 comprises at least a first layer 4, the first layer 4 preferably being a

conformable material for the user. Examples of liquid permeable materials are non-woven, perforated plastic films, plastic or textile web and water permeable foam materials. It is also known to use water permeable materials that constituted by thin continuous fibres that has an elongation essentially in the longitudinal or lateral direction of the article. It is also known
5 laminate comprising two or more of the abovementioned materials. It is also known combinations of different materials in different regions of the article. . The chassis may be constructed to support a separate absorbent core (not shown in figure 1) or to have an absorbent core placed between a top sheet and a back sheet. In case of a separate core, the core is placed into the chassis 2 either directly on top of a surface facing the user or in a
10 pocket designed to hold an absorbent core. A chassis having an absorbent core placed between a top sheet and a back sheet will be described in more detail below.

Both designs of a chassis 2 being constructed to support a separate absorbent core or having an absorbent core placed between a liquid pervious top sheet and a liquid impervious
15 back sheet are well known in the art. The chassis 2 may also comprise a laminate of two or more layers. The material or materials making up the chassis 2 are preferably washable in order for the chassis 2 to be used more than once.

The chassis 2 extends along its longitudinal direction X and lateral direction Y. The chassis 2
20 further comprises a first longitudinal side 5, a second longitudinal side 6, a first lateral side 7 and second lateral side 8. The chassis 2 is divided into a front portion 9 and a rear portion 10 with a crotch portion 11 located between the front portion 9 and the rear portion 10 in a longitudinal direction. In figure 1 the rear portion 10 comprises first fastening means 12 in order for the chassis to be detachably attached to the belt. Figure 1 shows that the rear
25 portion 10 comprises the first fastening means 12. The first fastening means 12 are separated by a first distance L_1 . The chassis 2 may be longitudinally symmetrical and laterally symmetrical such that the chassis 2 can be attached to the belt 3 at the front portion 9 and/or the rear portion 10.

30 The chassis 2 comprises first stretch markings 13. In figure 1 a pair of stretch markings are used. More than two stretch markings can be used as first stretch markings 13. The first stretch markings 13 are positioned along the first lateral side 7 and/or the second lateral side 8 of the chassis 2 in a lateral direction. The first stretch markings 13 are placed in relation to the first distance L_1 . This means that the first stretch markings 13 are always placed at a
35 specific distance from the first fastening means 12. This specific distance may be dependent on various parameters, for example the flexibility of the chassis, but the main purpose is to either directly or indirectly mark the position of the first fastening means 12. If the specific

distance is zero, then the first stretch markings 13 are positioned at the same position as the first fastening means 12 and thereby directly marks the position of the first fastening means 12. When the specific distance is zero, the distance between the first stretch markings 13 are equal to the first distance L_1 . This is illustrated in figures 2 and 3. The first fastening means 12 may constitute the first stretch markings 13. The first fastening means 12 and the first stretch markings 13 may be coloured in different colours. The first stretch markings may comprise at least two longitudinally extending marks separated from each other or at least two laterally extending marks separated from each other or two diagonally extending marks. Other shapes of stretch markings are possible such as arrows, triangles, circles, curvatures or other suitable geometric or pictorial shapes.

The belt 3 in figure 1 is shown in parts illustrating that the belt may be made in different lengths and the length of the belt 3 does not have to be related to the size of the lateral sides 7, 8 of the chassis 2. The belt 3 comprises a first end 14 and a second end 15. The belt 3 comprises second stretch markings 16 marking out a second distance L_2 when the belt is in the relaxed state. Figure 1 shows two broken lines marking that the first stretch markings 13 on the chassis should be placed inside the second distance L_2 , but may be positioned in conjunction with or on the second stretch markings, The invention is based on that the first distance L_1 is taken along the chassis and that the first distance L_1 gives enough slack for the chassis, when being attached to the belt when being in a non-stretched state, such that the belt can be stretched such that the slack is reduced but not to the extent that the stretched length of the belt is greater than the first distance L_1 . This means that the correlation between the first stretch markings 13 and the first attachment means 12 gives the possibility to arrange the second stretch markings 16 on the belt dependent on the features of the belt 3, i.e. e.g. stretchability, in such a way that the first stretch markings 13 can be positioned on the second stretch markings 16 or within the second distance L_2 and then attaching the first fastening means 12 to the belt 3 without jeopardizing that the first fastening means 12 becomes un-attached when the belt is stretched.

The belt 3 further comprises an inner surface 17 facing the user during use and an outer surface 18 facing away from the user during use. The outer surface 18 of the belt comprises second fastening means 19 arranged to cooperate with the first fastening means 12 in order for the chassis to be detachably attached to the belt. The first fastening means 12 of the chassis 2 and the second fastening means 19 of the belt will be explained, by way of example, based on the hook & loop connection between the chassis 2 and the belt 3 by means of hook elements and loop elements. It should be understood that the hook & loop connection is just for illustration, not limitation to the present invention. In fact, the hook elements may be replaced by adhesive strips while the corresponding loop elements may be

replaced by landing surfaces which are attachable to the adhesive strips. It is possible to position the hook element on the chassis 2 and the loop element on the belt 3 or vice versa.

Preferably, but not necessarily, the hook material is of the type "Moulded Hook Faster" from Velcro (see http://www.fasteningsystems.com/ultra_mate_hth_hook.html). The hooks have "palm tree shape" (see <http://www.velcro.com/index.php?page=business-products-all-ultra-mate>). The hook density is 140 ± 14 hooks/cm². Supplier is Velcro and the article code is "ULTRA-MATE HTH847®". The belt material (loop material) may be a laminate comprising a loop layer and a support layer. The loop layer, the important layer from hook & loop connection point of view, comprises the outer surface 18 of the belt 3. The loop layer is a 30 g/m² carded nonwoven, 2.2 dtex, 100% PP fibres. The carded loop layer is bonded with a Trie Trac pattern. Oriented toward the wearer is the support layer made of spun bond, 100% PP fibres, with a surface weight of 50 g/m². The support layer comprises the inner surface 17. The two layers constituting the laminate is ultrasonic point bonded together, with approximate 4mm between points. Supplier of the laminate is Fiberweb Tenotex. As an alternative to the above description, the belt 3 may be formed by nonwoven materials as a loop material, so as to use the belt itself as loop elements.

The belt 3 further comprises third fastening means 20 arranged at the first end 14 of the belt and fourth fastening means 21 arranged at the second end 15 of the belt 3. The third and fourth fastening means 20, 21 are intended to secure the belt 3 around the waist of a wearer. The third and fourth fastening means 20, 21 may be of the same kind as described for the first and second fastening means 12, 19 or the third and fourth fastening means 20, 21 may be different from the first and second fastening means 12, 19. The entire outer surface of the belt 3 may be covered with loop material, wherein the second fastening means 19 and the fourth fastening 21 means may be made from the same loop material.

The belt 3 comprises first elastic means 22 for allowing stretching of the belt during use in a lateral direction. As stated above, the belt 3 may be a laminate formed by at least two layers. The wearer facing layer of the belt 3, also referred to as "support layer", should be soft, non-irritating and comfortable against the skin. The garment facing layer of the belt, i.e., outermost layer, is of non-woven materials. The outermost layer itself may be used as a unitary loop element and is bonded to the supporting layer by any means known in the art such as ultrasonic welding, thermal welding, adhesive bonding etc. Both the layer facing the wearer and the layer facing the garment may be made of a nonwoven material. The first elastic mean may be sandwiched in between the two layers in the laminate. The belt may also be constructed such that the belt comprises just a single layer of material. In this case

the first elastic means 22 are attached to the outer surface 18 of the belt 3. The first elastic means may be elastic threads, elastic foam, elastic laminate or web. In figure 1 the belt 3 is elasticated along the entire length of the belt. It is possible to only elasticate part of the belt 3 as described below.

5

It should be noted that the front portion 9 is also equipped with fastening means 12 and that the first stretch markings 13 could be positioned in the front portion and in connection to the fastening means 12 in a corresponding manner to what has been described in connection to the back portion 10. Furthermore, both the front and back portion could be equipped with the

10

Figure 2 schematically shows an article 1 comprising a chassis 2 and a belt 3 according to a second aspect of the invention. The difference between the chassis described in figure 1 and the chassis described in figure 2 is that the first stretch markings 13 are placed essentially in

15

conjunction with the first fastening means 12. Figure 2 also shows the belt in stretched state and the second stretch markings 16 now marks out a third distance L3 between themselves. Regardless of the position of the first stretch markings 13, the first stretch markings 13 are positioned on or inside the second stretch markings 16 when the belt 3 is in a relaxed or

20

25

stretched state. Furthermore, in the relaxed state the distance between the first stretch markings 13 are greater than the second distance L2 and in the maximum stretched state the distance between the first stretch markings 13 are equal to or greater than the third distance L3. This causes the belt 3, when it contracts back to its relaxed state, to slightly crumple the front portion 9 and/or rear portion 10 of the chassis 2 that is attached to the belt 3. When the

35

belt 3 is stretched to a stretched state the front portion 9 and/or rear portion 10 of the chassis 2 that is attached to the belt 3 will then return to an essentially plane state. Figure 3 schematically shows an article 1 comprising a chassis 2 and a belt 3 according to a

30

third aspect of the invention. In figure 3, the first stretch markings 13 are positioned in the same position as the first fastening means 12 in the same way as depicted in figure 2. However, the example described in connection to figure 3 could also refer to a chassis having the first stretch markings 13 positioned according to according to figure 1. In figure 3 the belt 3 is stretched out to its maximum elongation. This means that the distance L3 has reached its predetermined maximum length.

and/or rear portion 10, in other words described as waist elastic. The second elastic means 23 may be elastic wire, cord, strip, thread, etc, interposed between a top sheet and a back sheet of the chassis by sewing, gluing, thermal welding, etc, so that the top sheet and back sheet are pleated when the waist elastic is relaxed. Alternatively, the second elastic means 5 23 may also be non-elastic nonwoven materials which is stretched or necked elasticized, or may be elastic laminate formed by laminating an elastic layer and a non-elastic layer. Although the second elastic means 23 is described above as an integral part of the chassis 2 between a top sheet and a back sheet, it may also be an elongate waist elastic produced separately and then attached to the chassis at one or both lateral sides 7, 8 thereof by known 10 means in the art, such as sewing, thermal welding, etc. with two attaching elements provided in the two ends of the separated waist elastic.

In figure 3 the second elastic means 23 of the chassis 2 is stretched out. This results in that the distance L_1 is increased and that the distance between the first stretch markings 13 is 15 increased accordingly. When the second elastic means 23 are stretched to its maximum the distance between the first stretch markings mark out a fourth distance L_4 . The fourth distance L_4 is essentially equal to or greater than the third distance L_3 of the belt 3 in its maximum stretched state. In figure 3 the distance between the first fastening means 12 are indicated as stretched out to their maximum distance L_4 .

20

In figure 3 the first stretch markings 13 are placed on or inside the second stretch markings 16 indicating that the maximum elongation of the belt 3 coincides with a predetermined elongation of the chassis 2. The first stretch markings 13 and the second stretch markings may also be arranged such that they are in line when both the chassis 2 and the belt 3 are 25 stretched out to their respective maximum elongation.

The second elastics 23 described in figure 3 could be used on the chassis described in connection to figure 1 and 2.

30 Figure 4 schematically shows an article 1 comprising a chassis 2 and a belt 3 according to a fourth aspect of the invention. The difference between the chassis 2 described in connection to figure 4 and the chassis described in figures 1-3 is that in figure 4 the first stretch markings 13 are placed outside the first fastening means 12. The same relationship between the first stretch markings 13 and the second stretch markings 16 as described in conjunction with the 35 previous aspects apply. In figure 4 the first fastening means 12 located along the second lateral edge 8 are separated by a different distance L_1 than the first fastening means 12 located along the first lateral edge 7. The distance between the first fastening means 12

located along the first and second lateral edge may be the same, or as shown in figure 4, different.

5 Figure 4 does not show second elastic means on the chassis as described in connection to figure 3, but the chassis 2 in figure 4 could be equipped with such second elastic means in the way described in connection to figure 3.

10 Figure 5 schematically shows a chassis 2 according to a fifth aspect of the invention. In this aspect the chassis 2 comprises an absorbent core 24 placed between a top sheet 25 and a back sheet 26. The top sheet 25 is the layer which lies in contact with the wearer's body when the core is in use. As such, it should be soft, non-irritating and comfortable against the skin, and bodily fluid should be able to pass through it without hindrance. The top sheet 25 can consist of a nonwoven material, e.g. spunbond, meltblown, carded, hydroentangled, wetlaid etc. Suitable nonwoven materials can be composed of natural fibres, such as wood
15 pulp or cotton fibres, manmade fibres, such as polyester, polyethylene, polypropylene, viscose etc or from a mixture of natural and manmade fibres. The top sheet 25 may further be composed of tow fibres, which may be bonded to each other in a bonding pattern. Further examples of materials suitable for top sheets are porous foams, apertured plastic films etc.

20 The back sheet 26 of the chassis 2 in this configuration is the layer which lies farthest from the wearer's body when the chassis 2 is in use. To protect the wearer's garments from soiling, it should be liquid-impermeable, but desirably gas-permeable (i.e. breathable) to allow air and vapour to pass in and out of the core so that the warm, damp conditions which can arise in the core are reduced. Typically, the back sheet 26 is of a liquid impervious
25 material, such as a thin plastic film, e.g. a polyethylene or polypropylene film, a nonwoven material coated with a liquid impervious material, a hydrophobic nonwoven material, which resists liquid penetration or a laminate comprising plastic films and nonwoven materials. Examples of breathable back sheet materials are porous polymeric films, nonwoven laminates from spunbond and meltblown layers, laminates from porous polymeric films and
30 nonwovens.

The absorbent core 24 of the chassis 2 in this configuration acts to receive and contain liquid and other bodily exudates and can be of any conventional kind. As such, it typically comprises absorbent material. Examples of commonly-occurring absorbent materials are
35 cellulosic fluff pulp, tissue layers, highly-absorbent polymers (so called superabsorbents), absorbent foam materials, absorbent nonwoven materials or the like. It is common to combine cellulosic fluff pulp with superabsorbents in an absorbent body. It is also common to

have absorbent cores comprising layers of different material with different properties with respect to liquid receiving capacity, liquid distribution capacity and storage capacity. The thin absorbent cores, which are common in for example baby diapers and incontinence guards, often comprise a compressed mixed or layered structure of cellulosic fluff pulp and superabsorbent. The absorbent core 24 may comprise one or more layers which are designed to improve the handling of bodily waste. Such layers are designed to receive a large amount of liquid in a short space of time and distribute it. They may include so-called transfer, distribution, surge or acquisition layers, and are usually located between the top sheet 25 and the absorbent core 24. The top sheet 25 and back sheet 26 generally have a similar extension in the plane of the chassis, while the absorbent core 24 has an extension which is somewhat smaller. The top sheet 25 and back sheet 26 are joined to one another around the periphery of the absorbent core 24, so that the core is enclosed within the envelope formed by the top sheet 25 and the back sheet 26. The absorbent core 24 is at least located in the crotch portion 11 of the chassis, and may also extend somewhat into the front portion 9 and rear portion 10. The top sheet 25 and back sheet 26 may be joined to one another by any means common in the art, e.g., ultrasonic welding, thermal welding or gluing.

The chassis 2 may or may not comprise leg elastics. In figure 5 leg elastics 27 are schematically illustrated. The leg elastics 27 may be any suitable elastics known in the art.

20

The chassis 2 described in figure 3 could be used in any of the examples described in connection to figures 1-4. The first stretch markings 13 could then be positioned accordingly and the chassis 2 could be equipped with second elastic means 23 as described in figure 3.

Figure 6 schematically shows a belt 3 according to a sixth aspect of the invention. In figure 6 the belt 3 comprises a first stretch zone 28 indicated by the shaded area. In figure 6 the belt 3 is elastic only in the first stretch zone 28. The remaining part of the belt 3 is essentially non-elastic. The first stretch zone 28 is thus sandwiched between two parts of essentially non-elastic members 29. It may of course be possible for a belt according to the invention to have more than one stretch zone 28. The belt will then have discrete zones where the belt is elastic, where each zone is sandwiched between two essentially non-elastic members. The first stretch zone 28 may comprise a coloured region 30. The coloured region 30 may comprise ink added to the outer surface 18 of the belt 3 which faces away from the user's body. The belt 3 shown in figure 6 may be used together with any of the configurations of chassis 2 described in conjunction with figures 1-5 above. The outer boundaries of the first stretch zone 28 then functions in the same way as the second stretch markings 16 of the belt 3 in figures 1-4. In case the first stretch zone 28 does not comprise a coloured region the

35

outer boundaries of the first stretch zone 28 may be indicated by a marking of a sort similar to the second stretch markings in figures 1-4.

5 Figure 7 schematically shows a chassis 2 and belt 3 prior to attachment of the chassis 2 to the belt 3. In figure 7 the belt 3 is curved to schematically indicate a suitable shape to put around the waist of a wearer. During use the belt 3 is of course closed using the third and fourth fastening means 20, 21. The belt 3 comprises a coloured region 30 on the outer surface 18 of the belt 3 that faces away from the wearer. The coloured region 30 marks out the stretch zone 28 described in figure 6. In figure 7 the belt 3 is in a stretched state as it is prepared to be put around the waist of a wearer. The position of the chassis 2 relative to the belt 3 is shown with the chassis 2 being placed at a distance from the belt 3 in figure 6 for simplicity. In reality the chassis 2 would be placed on the belt 3. As can be seen the first stretch markings 13 are placed outside of the coloured region 30 in order to achieve the purpose of the invention.

15

In all examples described in connection to figures 1-7 it is described only one pair of first stretch markings 13. However, in all examples it could be possible to have a chassis comprising a number of pairs of first stretch markings with different distance between each pair. For example, one first pair of first stretch markings could be spaced with a first length and a second pair of first stretch markings could be spaced with a second length being greater than the first length. The first pair of first stretch markings could then be used together with the second stretch markings for a thinner user and the second pair for a larger user, since the belt stretches less for the thin user and more for the larger user. In a further example, the belt may comprise one first pair of second stretch markings spaced with a first length and a second pair of second stretch markings spaced with a second length being greater than the first length. The first pair of second stretch markings could then be used together with the first stretch markings for a thinner user and the second pair for a larger user, since the belt stretches less for the thin user and more for the larger user. In yet another example both the chassis and the belt may comprise several pairs of stretch markings that could be matched to each other dependent on, for example, size of user, size of chassis and type of chassis.

20
25
30

Reference signs mentioned in the claims should not be seen as limiting the extent of the matter protected by the claims, and their sole function is to make claims easier to understand.

35

As will be realised, the invention is capable of modification in various obvious respects, all without departing from the scope of the appended claims. Accordingly, the drawings and the description thereto are to be regarded as illustrative in nature, and not restrictive. For instance the first stretch markings can be placed anywhere along either or both of the front
5 portion and rear portion of the chassis. The second stretch markings of the belt can be adjusted to suit different sizes of waists of users.

CLAIMS

1. An article (1) comprising a chassis (2) and a belt (3), the belt (3) being separate from the chassis (2) and arranged to be placed around the waist of a wearer; the belt (3) comprising
5 an inner surface (17) facing the user during use and an outer surface (18) facing away from the user during use; the belt (3) comprising first elastic means (22) for allowing stretching of the belt (3) during use in a lateral direction; the chassis (2) comprising at least a first layer (4) of a conformable material for the user; the chassis (2) comprising longitudinal sides (5, 6) and lateral sides (7, 8) and being divided into a front portion (9), a rear portion (10) and a
10 crotch portion (11) located between the front portion (9) and the rear portion (10) in a longitudinal direction; the front portion (9) and/or the rear portion (10) of the chassis (2) comprising a pair of first fastening means (12) arranged adjacent the longitudinal sides (5, 6) and being separated by a first distance (L1); the chassis (2) being arranged to be detachably attached to the outer surface (18) of the belt (3) by means of said first fastening means (12),
15 said outer surface (18) comprising second fastening means (19) arranged to be detachably attached to the first fastening means (12), **characterized in that** the chassis (2) comprises a pair of first stretch markings (13) being related to the first distance (L1) and that the belt (3) comprises a pair of second stretch markings (16) marking out a second distance (L2) when the belt (3) is in a relaxed state and a predetermined third distance (L3) when the belt (3) is
20 in a stretched state, wherein the first stretch markings (13) are intended to, be positioned in conjunction with the second stretch markings (16) or within the second distance (L2) for allowing the chassis (2) to be attached to the belt (3) via the first fastening means (12) and allowing the belt (3) to be stretched into the third distance (L3) without jeopardizing the fastening of the first fastening means (12).
- 25
2. An article (1) according to claim 1, wherein the first stretch markings (13) are positioned in conjunction with the first fastening means (12).
3. An article (1) according to claim 1 or 2, wherein the distance between the first stretch
30 markings (13) is greater than the second distance (L2) in the relaxed state and wherein the distance between the first stretch markings (13) is essentially equal to or greater than the third distance (L3) in the stretched state.
4. An article (1) according to any one of the preceding claims, wherein the second distance
35 (L2) is dependent on the stretchability of the first elastic means (22).

5. An article (1) according to any one of the preceding claims, wherein the chassis (2) comprises second elastic means (23), wherein the first stretch markings (13) marks out a fourth distance (L4) when the chassis (2) is in a predetermined maximum stretched state, wherein the fourth distance (L4) is essentially equal to or greater than the third distance (L3) in the stretched state.
6. An article (1) according to any one of the preceding claims, wherein the third distance (L3) relates to a predetermined maximum stretch value of the belt (3) in the stretched state.
7. An article (1) according to any one of the preceding claims, wherein the belt (3) comprises a first stretch zone (28), wherein the distance between the outer boundaries of the first stretch zone (28) when elongated to its maximum is less than or equal to the distance between the first stretch markings (13) in said chassis (2) when the chassis (2) is stretched out to its maximum.
8. An article (1) according to claims 7, wherein the distance between the outer boundaries of the first stretch zone (28) on the belt (3) when elongated to its maximum is less than or equal to the distance between the first stretch markings (13) on the said chassis (2) when the chassis (2) is stretched out to 90 % of its maximum, preferably to 80 % of its maximum.
9. An article (1) according to any of the claims 7-8, wherein that the first stretch zone (28) of the belt (3) comprises an elastic means sandwiched between two essentially non-elastic members.
10. An article (1) according to any one of claims 7-9, wherein the first stretch zone (28) on the belt (3) comprises a coloured region (30).
11. An article (1) according to any one of claims 7-10, wherein the first stretch zone (28) on the belt (3) comprises ink added to the outer surface of the material which is placed away from the user's body.
12. An article (1) according to any one of the preceding claims, wherein the chassis (2) and/or the belt (3) is made from a washable material.
13. An article (1) according to any one of the preceding claims, wherein chassis (2) comprises a top sheet (25), a back sheet (26) and an absorbent core (24) placed in-between the top sheet (25) and the back sheet (26).

14. An article (1) according to any one of the preceding claims, wherein the first fastening means (12) comprises loop material and the second fastening means (19) comprises hook material, or vice versa.

5

15. An article (1) according to any of the preceding claims, wherein the entire belt (3) is elasticated.

10

16. An article (1) according to any of the preceding claims, wherein the first stretch markings (13) on the chassis (2) comprises two transversal extending marks separated from each other.

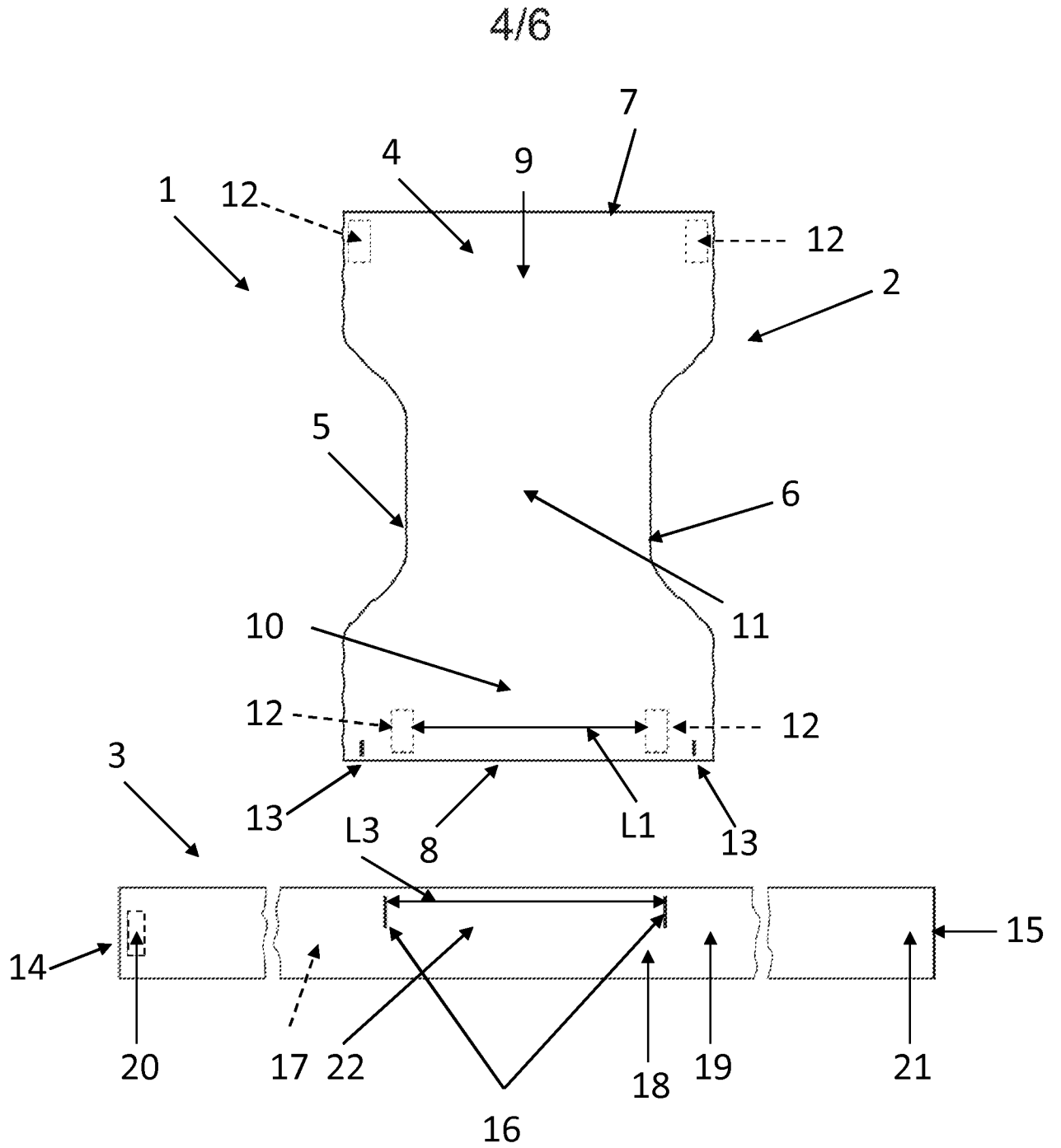

Fig.4

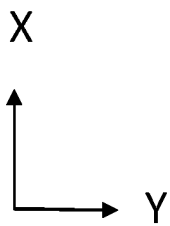
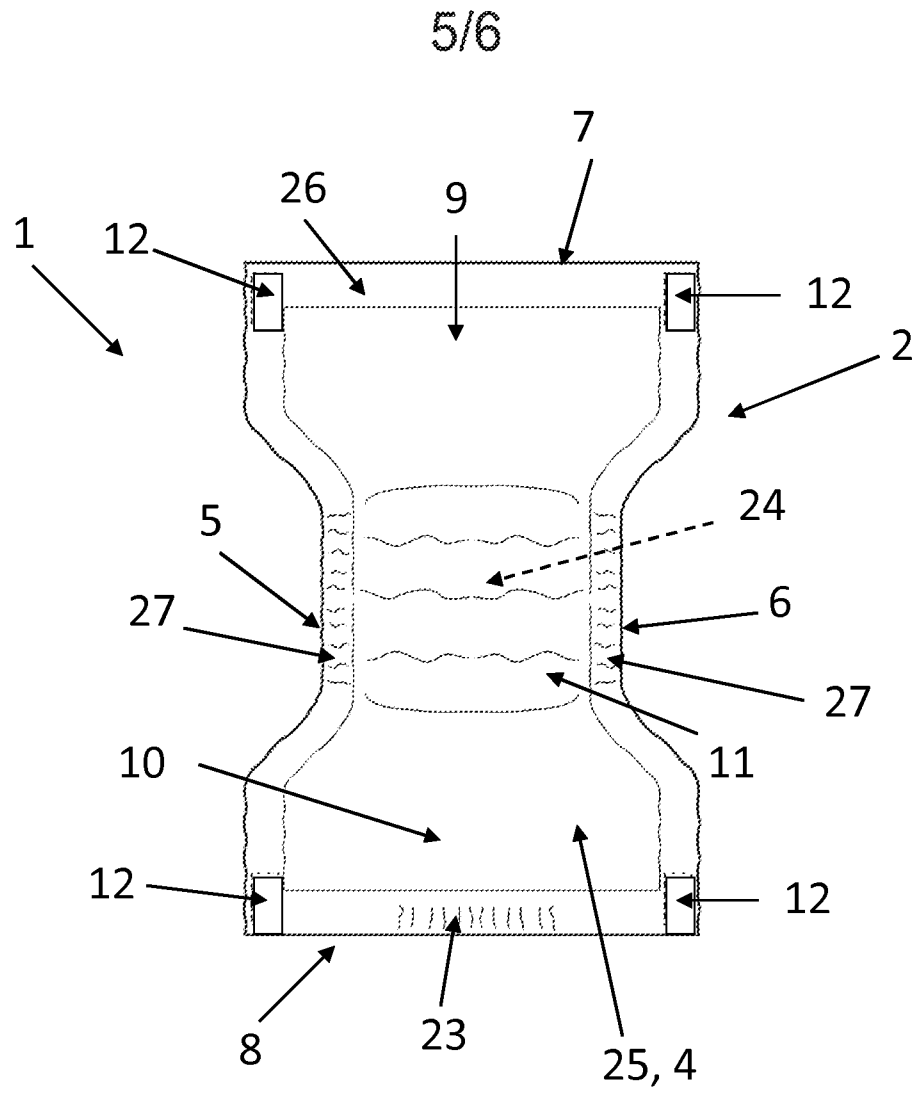

Fig.5

6/6

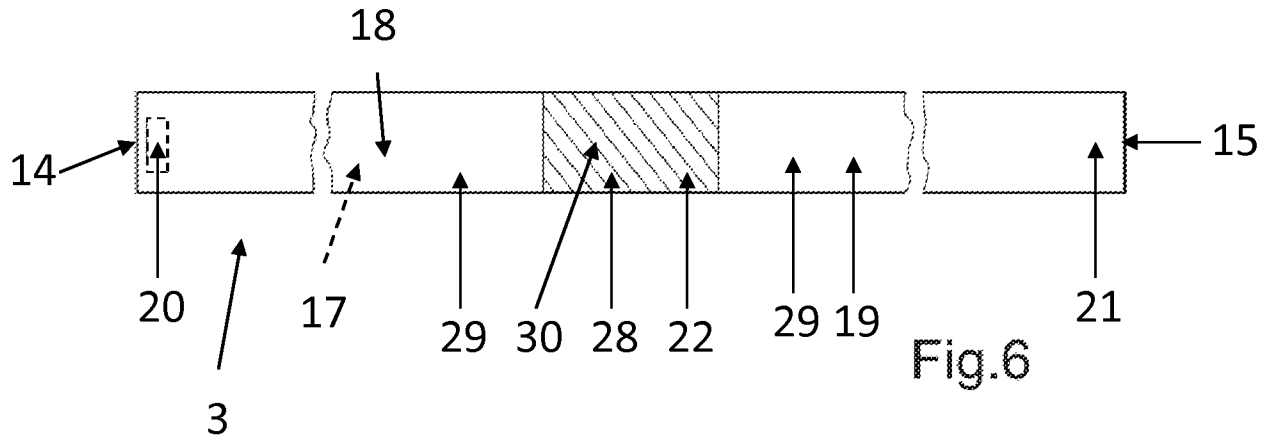

Fig.6

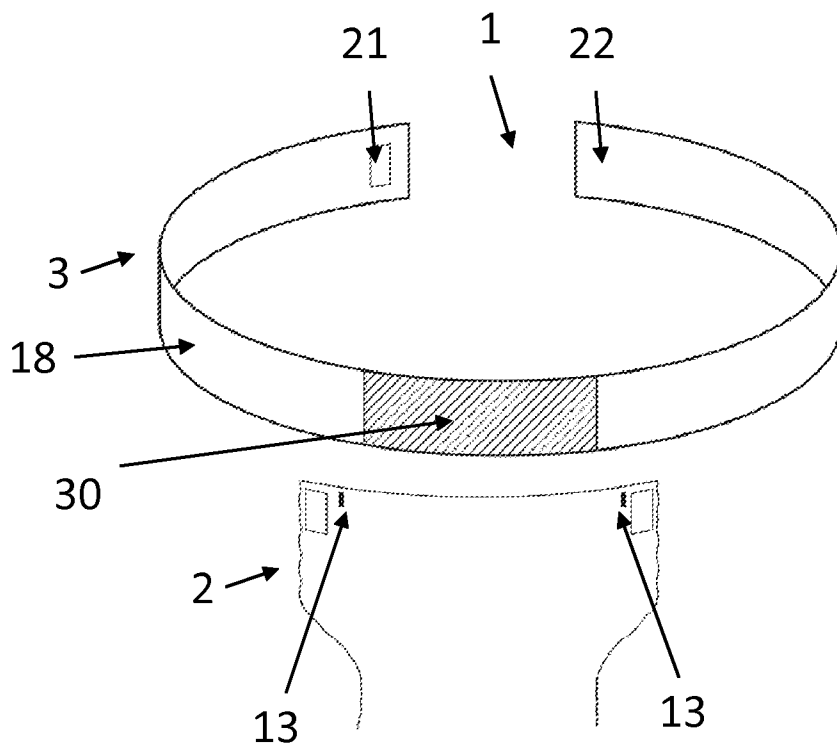

Fig.7

INTERNATIONAL SEARCH REPORT

International application No.
PCT/SE201 1/051495

A. CLASSIFICATION OF SUBJECT MATTER IPC: see extra sheet According to International Patent Classification (IPC) or to both national classification and IPC		
B. FIELDS SEARCHED Minimum documentation searched (classification system followed by classification symbols) IPC: A41 B, A61 F Documentation searched other than minimum documentation to the extent that such documents are included in the fields searched SE, DK, FI, NO classes as above Electronic data base consulted during the international search (name of data base and, where practicable, search terms used) EPO-Internal, PAJ, WPI data		
C. DOCUMENTS CONSIDERED TO BE RELEVANT		
Category*	Citation of document, with indication, where appropriate, of the relevant passages	Relevant to claim No.
X	EP 0409307 A2 (PROCTER & GAMBLE), 23 January 1991 (1991-01-23); abstract; column 3, line 9 - line 16; column 5, line 51 - column 6, line 24; figures 1-3 --	1-16
A	US 200901 82298 A 1 (KUMASAKA YOSHINORI), 16 July 2009 (2009-07-16); abstract; figures 1-2; [0013]-[0014] --	1-16
A	WO 990731 9 A 1 (KIMBERLY CLARK CO), 18 February 1999 (1999-02-18); abstract; figures 1-4; page 20 second paragraph, page 21 first and fourth paragraphs --	1-16
<input checked="" type="checkbox"/> Further documents are listed in the continuation of Box C. <input checked="" type="checkbox"/> See patent family annex.		
* Special categories of cited documents: "A" document defining the general state of the art which is not considered to be of particular relevance "E" earlier application or patent but published on or after the international filing date "L" document which may throw doubts on priority claim(s) or which is cited to establish the publication date of another citation or other special reason (as specified) "O" document referring to an oral disclosure, use, exhibition or other means "P" document published prior to the international filing date but later than the priority date claimed "T" later document published after the international filing date or priority date and not in conflict with the application but cited to understand the principle or theory underlying the invention "X" document of particular relevance; the claimed invention cannot be considered novel or cannot be considered to involve an inventive step when the document is taken alone "Y" document of particular relevance; the claimed invention cannot be considered to involve an inventive step when the document is combined with one or more other such documents, such combination being obvious to a person skilled in the art "&" document member of the same patent family		
Date of the actual completion of the international search 10-08-2012	Date of mailing of the international search report 13-08-2012	
Name and mailing address of the ISA/SE Patent- och registreringsverket Box 5055 S-102 42 STOCKHOLM Facsimile No. +46 8 666 02 86	Authorized officer Monika Bohlin Telephone No. +46 8 782 25 00	

INTERNATIONAL SEARCH REPORT

International application No.
PCT/SE201 1/051495

C (Continuation). DOCUMENTS CONSIDERED TO BE RELEVANT		
Category*	Citation of document, with indication, where appropriate, of the relevant passages	Relevant to claim No.
A	US 5 135522 A (FAHRENKRUG ANNE M ET AL), 4 August 1992 (1992-08-04); abstract; figures 1,5 --	1-16
A	JP 201 00821 39 A (OJI NEPIA CO LTD ET AL), 15 April 201 0 (201 0-04-1 5); (abstract) retrieved from: PAJ database; (abstract) retrieved from WPI database; Original document: Figures 1-12 --	1-16
A	US 5549593 A (YGGE BIRGITTA ET AL), 27 August 1996 (1996-08-27); abstract; column 2, line 65 - column 3, line 44; figures 1-7 --	1-16
A	EP 0648482 A2 (UNI CHARM CORP), 19 April 1995 (1995-04-19); abstract; figure 1 --	1-16
A	WO 20090431 01 A1 (KUEVER DESIGNS PTY LTD ET AL), 9 April 2009 (2009-04-09) ; abstract; page 11, line 4 - line 14; figures 1-2 --	1-16
A	WO 961481 5 A1 (PROCTER & GAMBLE), 23 May 1996 (1996-05-23); abstract; figures 10a-b; page 25 first and second paragraphs -- -----	1-16

Continuation of: second sheet

International Patent Classification (IPC)

A41B 9/14 (2006.01)

A61F 5/457 (2006.01)

A61F 13/70 (2006.01)

A61F 13/505 (2006.01)

Download your patent documents at www.prv.se

The cited patent documents can be downloaded:

- From "Cited documents" found under our online services at www.prv.se
(English version)
- From "Anforda dokument" found under "e-tjanster" at www.prv.se
(Swedish version)

Use the application number as username. The password is **NCGTYZIGMQ**.

Paper copies can be ordered at a cost of 50 SEK per copy from PRV InterPat (telephone number 08-782 28 85).

Cited literature, if any, will be enclosed in paper form.

INTERNATIONAL SEARCH REPORT

Information on patent family members

International application No.

PCT/SE201 1/051495

EP	0409307	A2	23/01/1991	AT	142472	T	15/09/1996
				AU	655735	B2	05/01/1995
				AU	647743	B2	31/03/1994
				AU	5905490	A	24/01/1991
				AU	5515094	A	05/05/1994
				BR	9003479	A	27/08/1991
				CA	2019880	A 1	18/01/1991
				CN	1028602	C	31/05/1995
				CN	1048798	A	30/01/1991
				DE	69028459	T2	06/02/1997
				EG	18823	A	28/02/1994
				ES	2091 786	T3	16/1 1/1996
				FI	100378	B	28/1 1/1997
				GR	3021462	T3	31/01/1997
				IE	902604	A 1	27/02/1991
				IE	741 90	B 1	16/07/1997
				JP	20031 11795	A	15/04/2003
				JP	3483873	B2	06/01/2004
				JP	3 136652	A	11/06/1991
				KR	0 18001 1	B 1	01/04/1999
				MA	2 1908	A 1	01/04/1991
				NZ	234548	A	27/09/1993
				PT	9471 6	B	31/1 0/1997
				TR	27286	A	26/1 2/1994
				US	5445628	A	29/08/1995
US	200901 82298	A 1	16/07/2009	AU	4083900	A	21/1 2/2000
				AU	774765	B2	08/07/2004
				CA	231 1469	C	29/03/2005
				CN	10 1172075	A	07/05/2008
				CN	127701 2	A	20/1 2/2000
				DE	6001 8509	T2	26/01/2006
				EP	1060721	A3	20/06/2001
				ID	26389	A	21/1 2/2000
				JP	2000354606	A	26/1 2/2000
				JP	3492242	B2	03/02/2004
				KR	100661 885	B 1	28/1 2/2006
				KR	2001 0007365	A	26/01/2001
				US	82121 02	B2	03/07/201 2

INTERNATIONAL SEARCH REPORT

Information on patent family members

International application No.

PCT/SE201 1/051495

WO	9907319	A1	18/02/1999	AR	016794	A1	01/08/2001
				AU	8602298	A	01/03/1999
				AU	731 193	B2	29/03/2001
				BR	9815533	A	12/06/2001
				CA	2289029	A1	18/02/1999
				CO	5060486	A1	30/07/2001
				DE	698281 70	T2	22/1 2/2005
				EP	1001 726	B1	15/1 2/2004
				JP	4267200	B2	27/05/2009
				JP	2001 513364	A	04/09/2001
				US	6402731	B1	11/06/2002
US	5 135522	A	04/08/1992	BR	9 10 13 11	A	26/1 1/1991
				CA	2023043	A1	03/1 0/1991
				GB	224261 2	B	24/1 1/1993
				HK	83694	A	26/08/1994
				KR	0 15 1594	B1	01/1 0/1998
				ZA	9 10 1992	A	24/1 2/1991
JP	201 00821 39	A	15/04/201 0	NONE			
us	5549593	A	27/08/1996	NONE			
EP	0648482	A2	19/04/1995	AU	74481 94	A	04/05/1995
				AU	685833	B2	29/01/1998
				CA	2 1 1781 0	C	27/04/1999
				CN	2217400	Y	17/01/1996
				DE	69426964	D1	03/05/2001
				ES	2 155083	T3	01/05/2001
				KR	2001 43303	Y1	01/06/1999
				SG	52346	A1	28/09/1998
				US	560741 6	A	04/03/1997
WO	20090431 01	A1	09/04/2009	AU	20083071 42	A1	09/04/2009
				CA	2701 574	A1	09/04/2009
				CN	101854899	A	06/1 0/201 0
				EP	220751 5	A1	21/07/201 0
				JP	201 05401 25	A	24/1 2/201 0
				KR	201 00075499	A	02/07/201 0
				MX	201 0003694	A	17/05/201 0
				US	201 00036340	A1	11/02/201 0

INTERNATIONAL SEARCH REPORT

Information on patent family members

International application No.

PCT/SE201 1/051495

WO	961 4815 A 1	23/05/1 996	AT	193825 T	15/06/2000
			AU	4 135296 A	06/06/1996
			AU	708896 B2	12/08/1999
			BR	9509709 A	30/09/1997
			CA	2203794 A 1	23/05/1996
			CN	117 1733 A	28/01/1998
			DE	6951 7534 T2	08/03/2001
			EP	079081 5 B 1	14/06/2000
			ES	2 146786 T3	16/08/2000
			JP	H 10509361 A	14/09/1998
			KR	100234465 B 1	15/1 2/1999
			MX	9703395 A	31/07/1997
			US	5577540 A	26/1 1/1996
			US	5542943 A	06/08/1996
			ZA	9509484 A	15/05/1996
