



- (51) International Patent Classification:
H04N 21/242 (2011.01)
- (21) International Application Number:
PCT/US2016/018543
- (22) International Filing Date:
18 February 2016 (18.02.2016)
- (25) Filing Language:
English
- (26) Publication Language:
English
- (30) Priority Data:
62/117,899 18 February 2015 (18.02.2015) US
15/047,548 18 February 2016 (18.02.2016) US
- (71) Applicant: **BLACKFIRE RESEARCH CORPORATION** [US/US]; 1465 Bush Street, San Francisco, CA 94109 (US).
- (72) Inventor: **RAJAPAKSE, Ravi**; 1820 Lyon Street, San Francisco, CA 94115 (US).

(74) Agent: **GALVIN, Brian, R.**; GALVIN PATENT LAW LLC, 2916 NW Bucklin Hill Road, Suite 485, Silverdale, WA 98383 (US).

(81) Designated States (unless otherwise indicated, for every kind of national protection available): AE, AG, AL, AM, AO, AT, AU, AZ, BA, BB, BG, BH, BN, BR, BW, BY, BZ, CA, CH, CL, CN, CO, CR, CU, CZ, DE, DK, DM, DO, DZ, EC, EE, EG, ES, FI, GB, GD, GE, GH, GM, GT, HN, HR, HU, ID, IL, IN, IR, IS, JP, KE, KG, KN, KP, KR, KZ, LA, LC, LK, LR, LS, LU, LY, MA, MD, ME, MG, MK, MN, MW, MX, MY, MZ, NA, NG, NI, NO, NZ, OM, PA, PE, PG, PH, PL, PT, QA, RO, RS, RU, RW, SA, SC, SD, SE, SG, SK, SL, SM, ST, SV, SY, TH, TJ, TM, TN, TR, TT, TZ, UA, UG, US, UZ, VC, VN, ZA, ZM, ZW.

(84) Designated States (unless otherwise indicated, for every kind of regional protection available): ARIPO (BW, GH, GM, KE, LR, LS, MW, MZ, NA, RW, SD, SL, ST, SZ, TZ, UG, ZM, ZW), Eurasian (AM, AZ, BY, KG, KZ, RU, TJ, TM), European (AL, AT, BE, BG, CH, CY, CZ, DE, DK, EE, ES, FI, FR, GB, GR, HR, HU, IE, IS, IT, LT, LU, LV, MC, MK, MT, NL, NO, PL, PT, RO, RS, SE, SI, SK,

[Continued on next page]

(54) Title: SYNCHRONOUS MEDIA RENDERING OVER WIRELESS NETWORKS WITH WIRELESS PERFORMANCE MONITORING

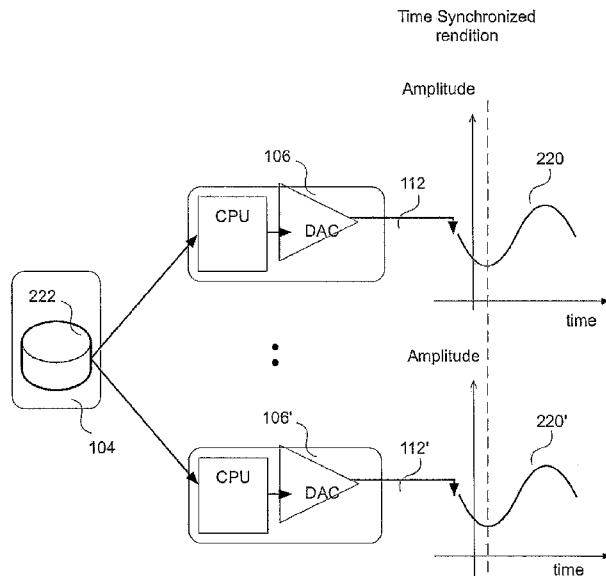

Fig. 1

(57) Abstract: A system for synchronous media rendering over wireless networks with wireless performance monitoring, comprising a media source device and a plurality of destination devices, a quality analysis module operating on at least one of the devices to monitor the media being streamed and direct the operation of a synchronization module, and a synchronization module operating on at least one of the devices to direct the rendering of media data based on received event data and to transmit event data to at least a portion of the destination devices, and a method for common event-based multidevice media synchronization and quality analysis.

WO 2016/134186 A1



SM, TR), OAPI (BF, BJ, CF, CG, CI, CM, GA, GN, GQ, GW, KM, ML, MR, NE, SN, TD, TG).

— *before the expiration of the time limit for amending the claims and to be republished in the event of receipt of amendments (Rule 48.2(h))*

Published:

— *with international search report (Art. 21(3))*

SYNCHRONOUS MEDIA RENDERING OVER WIRELESS
NETWORKS WITH WIRELESS PERFORMANCE MONITORING

CROSS-REFERENCE TO RELATED APPLICATIONS

[001] This application is a PCT filing of and claims priority to US patent application serial number 15/047,548, titled “SYSTEM AND METHOD FOR SYNCHRONOUS MEDIA RENDERING OVER WIRELESS NETWORKS WITH WIRELESS PERFORMANCE MONITORING,” which was filed on February 18, 2016, which claims the benefit of, and priority to, United States provisional patent application serial number 62/117,899, titled “COMMON EVENT-BASED MULTIDEVICE MEDIA SYNCHRONIZATION AND QUALITY ANALYSIS”, filed on February 18, 2015, and is also a continuation-in-part of United States patent application serial number 14/505,411, titled “COMMON EVENT-BASED MULTIDEVICE MEDIA PLAYBACK”, filed on October 2, 2014, which is a continuation of United States patent application serial number 14/303,502, titled “SYNCHRONOUS PLAYBACK OF MEDIA USING A WI-FI NETWORK WITH THE MEDIA ORIGINATING FROM A BLUETOOTH SOURCE”, filed on June 12, 2014, which claims the benefit of, and priority to, United States provisional patent application serial number 61/833,927, titled “SYNCHRONOUS PLAYBACK OF MEDIA USING A WI-FI NETWORK WITH THE MEDIA ORIGINATING FROM A BLUETOOTH SOURCE”, filed on June 12, 2013, the entire specification of which is incorporated herein by reference, and which is also a continuation-in-part of United States patent application serial number 13/561,029, titled “PACKET LOSS ANTICIPATION AND PRE EMPTIVE RETRANSMISSION FOR LOW LATENCY MEDIA APPLICATIONS” filed on July 28, 2012, now issued as United States patent 8,839,065 on September 16, 2014, and is a continuation-in-part of United States patent application serial number 14/083,426, titled “COMMON EVENT BASED MULTI DEVICE PLAYBACK, filed on November 18, 2013, now issued as United States patent 8,762,580 on June 24, 2014, which is a continuation-in-part of United States patent application serial number 11/627,957, titled “Streaming Media System and

Method” and filed on January 27, 2007, now issued as United States patent 8,677,002 on March 18, 2014, and claims the benefit of, and priority, to United States provisional patent application serial number 61/727,624, filed on November 16, 2012, titled “COMMON EVEN BASED MULTIDEVICE MEDIA PLAYBACK” the entire specification of each of which is incorporated herein by reference, and which is also a continuation of United States patent application serial number 14/303,527, titled “BROADCASTING MEDIA FROM A STATIONARY SOURCE TO MULTIPLE MOBILE DEVICES OVER WI-FI” and filed on June 12, 2014, which claims the benefit of, and priority to, United States provisional patent application serial number 61/833,928, titled “BROADCASTING MEDIA FROM A STATIONARY SOURCE TO MULTIPLE MOBILE DEVICES OVER WI-FI ”, filed on June 12, 2013, the entire specification of which is incorporated herein by reference, and is also a continuation-in-part of United States patent application serial number 13/561,029, titled “PACKET LOSS ANTICIPATION AND PRE EMPTIVE RETRANSMISSION FOR LOW LATENCY MEDIA APPLICATIONS” filed on July 28, 2012, now issued as United States patent 8,839,065 on September 16, 2014, and is a continuation-in-part of United States patent application serial number 14/083,426, titled “COMMON EVENT BASED MULTI DEVICE PLAYBACK, filed on November 18, 2013, now issued as United States patent 8,762,580 on June 24, 2014, which is a continuation-in-part of United States patent application serial number, titled “Streaming Media System and Method” and filed on January 27, 2007, now issued as United States patent 8,677,002 on March 18, 2014, and also claims a benefit of, and priority, to United States provisional patent application serial number 61/727,624, filed on November 16/627,957, 2012, titled “COMMON EVEN BASED MULTIDEVICE MEDIA PLAYBACK” the entire specification of each of which is incorporated herein by reference in their entirety.

BACKGROUND OF THE INVENTION

Field of the Art

[002] The disclosure relates to the field of digital media, and more particularly to the field of synchronized digital multimedia playback.

Discussion of the State of the Art

[003] Today there are many forms of digital media, many types of digital media sources, many types of digital media playback (rendering) systems and lots of ways of connecting media sources to media playback systems.

[004] Digital media, hereafter referred to as media, comes in many forms, formats and containers, including Digital Video Disks, media files and media streams. The media contents can be audio, video, images or meta data media components and various combinations of each. For example, a popular audio format is known as MP3 and a popular video format is H264. MP3 is an audio-specific media format that was designed by the Moving Picture Experts Group (MPEG) as part of its MPEG-1 standard and later extended in the MPEG-2 standard. H264 is a standard developed by the International Organization for Standardization (ISO)/International Electrotechnical Commission (IEC) joint working group, the Moving Picture Experts Group (MPEG). Movies are typically multimedia formats with a video and multiple audio channels in it. For example, a 5.1 movie contains 1 video channel (media component) and 6 audio channels (audio components). 5.1 is the common name for six channel surround sound multichannel audio systems.

[005] Digital media sources include media devices such as Digital Video Disk players, Blu-ray players, computer and mobile devices, and internet based “cloud” media services. Blu-ray Disc (BD) is an optical disc storage medium developed by the Blu-ray Disc Association. Internet based media services include services such as NETFLIX™ and SPOTIFY™. Netflix is a media service and trademark of Netflix Inc. SPOTIFY™ is a media service and trademark of Spotify Ltd. Digital media playback (media rendering destinations) systems include computer based devices, laptops and smartphones, as well as network audio and video devices. A SmartTV is an example of a digital media-rendering device that can play media from an internet (cloud) based media service such as NETFLIX™. A SmartTV, which is also sometimes referred to as “Connected TV” or “Hybrid TV”, is used to describe the integration of the internet and Web features into modern television sets and set-top boxes, as well as the technological

convergence between computers and these television sets/set-top boxes. An Internet radio device is another example of a digital media rendering device.

[006] The connectivity between these media sources and devices is varied, but is evolving over time towards network-based connectivity using Internet protocol (IP) protocols. This is because IP connectivity is convenient, ubiquitous, and cheap.

[007] IP networks come in many forms; the most prevalent being Ethernet based wired IP networking. Ethernet is a family of computer networking technologies for local area networks (LANs) that is standardized as IEEE (Institute of Electrical and Electronics Engineers) Standard 802.3. In recent years with the prevalence of mobile computing devices, Wi-Fi (a type of IP network) has become the most popular means for connecting network devices wirelessly. Wi-Fi is a trademark of the Wi-Fi Alliance and a brand name for products using the IEEE 802.11 family of standards. IP networks can use several different types of messaging including unicast, multicast, and broadcast messaging, such messaging being the sending of IP packets.

[008] The term "Unicast" may be used to refer to a type of Internet Protocol transmission in which information is sent from only one sender to only one receiver. In other words, unicast transmission is a one-to-one node transmission between two nodes only. In unicasting each outgoing packet has a unicast destination address, which means it is destined for a particular destination that has that address. All other destinations that may hear that packet ignore the packet, if the packet's destination address is not the same as that destination's address.

[009] Many IP protocols are accessed from software programs via a socket application programming interface. This socket interface is defined as part of the POSIX standard. POSIX is an acronym for "Portable Operating System Interface", which is a family of standards specified by the IEEE for maintaining compatibility between operating systems.

[010] The convenience and benefits of IP networking means that all of these media sources and playback systems, if not already network enabled, are becoming network enabled. Many Blu-ray players now have Ethernet and Wi-Fi network connectivity.

Today most higher-end TVs are smart TVs that have network capability. Similarly, audio play back devices and even radios are network and Internet enabled.

[011] Mobile devices, such as mobile phones, tablets, document readers, or notebooks, are able to receive and store media and have powerful multimedia (audio and video) capabilities and may be connected to the internet via cell phone data services or broadband links (such as Wi-Fi) that are high bandwidth and can access online media services that have wide and deep content.

[012] The use cases or applications of these various forms of digital media, media services and media sources and playback systems have been evolving. Initially it was enough to connect a media source to a media destination over an IP network. This is widely used today with Internet based media source services, such as Netflix and a computer as a media destination. Users watch Netflix movies streamed over a wired IP network (the internet) to a computer. This is a case of a single point (one IP source) to single point (one IP destination) connection over a wired IP network. Even though the Netflix media service may send the same media to multiple households, each of these is a single point to single point TCP/IP connection. A further evolution of this is to use a wireless, Wi-Fi connection, instead of a wired Ethernet connection. This is still a single point to single point connection.

[013] A further extension of the above use cases exists, where a media source connects to multiple destinations rather than a single destination. These are single point (one IP source) to multi point (multiple IP destinations) applications. An example would be where a user is playing a 5.1 movie media file to a wireless video playback device and 6 independent wireless audio destinations making up a full 5.1 surround sound system. In this case the media is going from one media source to 7 media destinations simultaneously. In another example, a user is playing music from one media source to six audio playback systems placed around the home in six different rooms.

[014] In both of these cases, it is necessary to play (render) the media at all destinations time synchronously. Furthermore, it is necessary to limit the use of resources at the media source, such as keeping memory use to a minimum. In

addition, it is necessary with multiple devices receiving media to manage network bandwidth efficiently.

[015] Currently when the same media data needs to be sent to multiple network destinations, the general technique for doing so is to use data multicasting to the multiple destinations that need to receive the data. In such a system, the media is multicast to all the destinations and it is up to each destination to attempt to render the media appropriately. If during rendering there is an error where a renderer does not receive new media data or does not receive it correctly, the renderer may render erroneous data and then attempt to recover and continue correct media rendering from the point after the error when correct data is received.

[016] In the applications envisioned here, there is a need to send media from a source to multiple media devices, such as TV and speakers in the same listening and viewing space. Furthermore, there is a need to send this media over a wireless network such as Wi-Fi.

[017] For these applications, this means all of the media rendering devices, such as speakers, that are in the same listening or viewing zone, need to be precisely synchronized to each other, so the listener and/or viewer does not discern any unintended media experience.

[018] Secondly, because the media is transported over wireless, there is a very high likelihood of a media error, where the media is not received at each destination reliably or uniformly. If using broadcast or multicasts to send packets, the same broadcast or multicast packet, may be received at one destination but not received/heard by another destination.

SUMMARY OF THE INVENTION

[019] Accordingly, the inventor has conceived and reduced to practice, in a preferred embodiment of the invention, a system and method for synchronous media rendering over wireless networks with wireless performance monitoring, that solves the above problems of media error and loss of synchronization when transmitting to multiple media receiver devices.

[020] According to a preferred embodiment, a system for synchronous media rendering over wireless networks with wireless performance monitoring, comprising a plurality of media devices comprising at least a source device and a plurality of destination devices, the source device comprising a plurality of software programming instructions stored in a memory of and operating on a processor of a computing device and configured to stream media over the network, and the destination devices each comprising at least a local clock and connected via the network to the source device and configured to render media received over the network; a quality analysis module operating on at least one of the plurality of devices and configured to monitor at least a portion of the media being streamed over the network, and configured to direct the operation of a synchronization module based at least in part on the analysis results; and a synchronization module operating on at least one of the plurality of devices and configured to direct the rendering of media data based on received event data, and configured to transmit event data to at least a portion of the destination devices, is disclosed.

[021] According to another preferred embodiment, a method for synchronous media rendering over wireless networks with wireless performance monitoring, comprising the steps of receiving, at a comprising at least a local clock and connected via the network to the source device and configured to render media received over the network, media data comprising at least event data and media for rendering; rendering, using a synchronization module operating on at least one of the plurality of devices and configured to direct the rendering of media data based on received event data, and configured to transmit event data to at least a portion of the destination devices, the media data based at least in part on the event data; monitoring, using a quality analysis module operating on at least one of the plurality of devices and configured to monitor at least a portion of the media being streamed over the network, and configured to direct the operation of the synchronization module based at least in part on the analysis results, at least a portion of the media as it is rendered; analyzing at least the monitored portion of the media rendering; and transmitting event data based at least in part on the analysis results, is disclosed.

[022] According to a further embodiment, a system for for synchronous media rendering over wireless networks with wireless performance monitoring comprising a plurality of media playback devices each of which maintains audio phase and timing through synchronization based on crystal clock cycles, is disclosed. According to the embodiment, a plurality of media playback devices may be connected to a plurality of media source devices by way of an IP-enabled network such as the Internet or any other data network utilizing an IP protocol. Media may be broadcast over such a network to playback devices, each of which may play similar or distinct media elements as may be desirable during playback (for example, one speaker may play the left audio channel while a second speaker the right audio channel, as is common in sound systems in the art).

[023] According to a further embodiment, a system for for synchronous media rendering over wireless networks with wireless performance monitoring, comprising a media source device and a plurality of destination devices each comprising a local clock, is disclosed. The synchronization module in the media source device transmits a common events E_n , comprising a unique event number n at the media source to each of the plurality of destination devices. Each destination device records time Dx_n when event E_n is received and transmits an acknowledgement message back to the synchronization module comprising time Dx_n and the unique event number n . The synchronization module, for each of the plurality of receiver devices, determines the phase and frequency differences between the clock signal of the respective receiver devices; computes a phase and frequency adjustment to compensate for differences; and directs the respective destination device to adjust its clock phase and frequency accordingly. Each receiver device adjusts its local clock as directed or performs a sample rate conversion in order to synchronize media playback.

[024] According to a further embodiment, a method for for synchronous media rendering over wireless networks with wireless performance monitoring is disclosed, the method comprising the steps of: (a) periodically transmitting, from a media source device, containing a synchronization module, and connected to a network and adapted to stream media over the network, a common event E_n comprising a unique event number n ; (b) receiving via the network, at each of a plurality of receiver devices

comprising a local clock, the event E_n ; (c) recording at each receiving device a time Dx_n when event E_n is received; (d) transmitting an acknowledgement message from each receiving device back to the media source comprising at least the time Dx_n and the unique event number n (e) determining, using a synchronization module stored and operating on one of the media source device and the plurality of destination devices, the phase and frequency difference between the clock signals of the respective destination devices; (f) computing a frequency adjustment to compensate for the phase and frequency difference determined in step (e); (g) directing the respective receiver device to adjust its clock phase and frequency by an amount equal to the frequency adjustment computed in step (f); and (h) adjusting the local clock of each receiver device as directed in step (c) in order to synchronize media playback.

[025] According to a further embodiment of the invention, a system for for synchronous media rendering over wireless networks with wireless performance monitoring comprising a plurality of media sources (such as a media server computer, media storage such as a database or physical storage media, or other such source of multimedia data for playback on suitable devices) communicating over a data network (such as the Internet, for example via a wired Ethernet or wireless WiFi, BLUETOOTH™, or other wireless communication protocol for communicating over airwaves using radio, acoustic, or other suitable means) and a plurality of media playback devices (such as any suitable device for playing a desired multimedia file, for example a smartphone, personal computer, audio player, television, or other devices as may be suitable according to the nature of the media desired for viewing), is disclosed. According to the embodiment, a quality analysis module (“QAM”) 1503, 1603 comprising program code adapted to monitor, log, and analyze various network and multimedia metrics may be utilized, and may be in communication with a multimedia source or destination device to receive and process information from such devices for quality analysis purposes. It should be appreciated that multiple QAM 1503, 1603 components may be utilized, for example having a QAM 1503, 1603 on a media source device, and a QAM 1503, 1603 operated by one or more media playback devices, and that various arrangements may be used interchangeably according to the invention. According to the embodiment, a QAM 1503, 1603 may monitor multimedia

playback or network connectivity, for example by receiving metricized information from various connected devices (or optionally only from the device operating the QAM 1503, 1603) and analyzing the information to determine changes in metrics (as may indicate performance loss or other changes to playback or network connectivity), or to compare a received metric value to known values to determine its overall quality (for example, a “scoring” system that may be used to determine whether a metric is within acceptable or ideal parameters). As is common in the art, various aspects of a network connection may be monitored and analyzed, such as upload and download speeds, packet loss, “ping” or packet travel times, latency, and other various metrics that are commonly measured to determine the quality of a particular network layout or a connection to a network. Additionally, a QAM 1503, 1603 utilized according to the invention may monitor various aspects of multimedia playback to determine the quality of playback via a network according to the invention, for example by analyzing audio or video bitrate (to determine the quality of a particular media stream), processing latency (to analyze the timing offset produced by any processing or transcoding performed on a media stream, for example by a processor to convert a media stream into a format compatible with a particular destination device), signal-to-noise ratio (to monitor unwanted noise or other artifacts that may affect a viewer’s experience), or timing information between multiple devices, to ensure optimum synchronicity between devices during playback. According to the embodiment, various media playback events may optionally comprise additional information pertaining to quality analysis, such as timing or other information gathered from the device or multimedia file(s) pertaining to the event. In this manner, event-based playback may be enhanced by including various performance metrics for monitoring, and by continuously monitoring those metrics and other readily available information to ensure an optimum multimedia viewing experience.

[026] According to the embodiment, a QAM 1503, 1603 may be operated by any device in a multimedia playback arrangement according to the invention, and may receive events and other information via the network. In this manner, performance of multiple devices as well as the network being used for playback may be monitored from any device on the network, without special consideration for its function in the

arrangement. Additionally, a QAM 1503, 1603 may present quality information for viewing or interaction, for example (in an arrangement with a QAM 1503, 1603 operating on a mobile device) by using a web interface or a software application that may make quality information accessible to users. For example, various metrics may be presented in an easily understood format, along with options for taking action based on the values observed (such as, for example, applying an offset to an audio or video stream to account for latency). In this manner, quality analysis may be interactive as desired, giving users a fine granularity of control over their playback experience without necessarily requiring any more complexity from a user (they may simply continue playing media without utilizing any of the QAM 1503, 1603 features of desired), thereby providing a level of interaction and control suitable for different users of different levels of technical ability or interest.

BRIEF DESCRIPTION OF THE DRAWING FIGURES

[027] The accompanying drawings illustrate several embodiments of the disclosed configuration and, together with the description, serve to explain the principles of the invention according to the embodiments. One skilled in the art will recognize that the particular embodiments illustrated in the drawings are merely exemplary, and are not intended to limit the scope of the disclosed embodiments.

[028] **Fig. 1** is an illustration of an exemplary multimedia system comprising two audio subsystems, according to an embodiment of the invention.

[029] **Fig. 2** is a detailed illustration of an exemplary audio playback system, according to an embodiment of the invention.

[030] **Fig. 3** is an illustration of an exemplary clock-based system for time referencing, according to an embodiment of the invention.

[031] **Fig. 4** is an illustration of an exemplary message timeline, according to an embodiment of the invention.

[032] **Fig. 5** is an illustration of an exemplary common event-based system according to an embodiment of the invention.

[033] Fig. 6 is an illustration of an exemplary event timeline according to an embodiment of the invention.

[034] Fig. 7 is an illustration detailing differences between the common clock method and the common event method according to an embodiment of the invention.

[035] Fig. 8 is an illustration of the overall effect of using a common event-based system according to an embodiment of the invention.

[036] Fig. 9 is an illustration of the overall effect of using a common event-based algorithm according to an embodiment of the invention.

[037] Fig. 10 is a block diagram illustrating an exemplary hardware architecture of a computing device used in an embodiment of an embodiment of the invention.

[038] Fig. 11 is a block diagram illustrating an exemplary logical architecture for a client device, according to an embodiment of an embodiment of the invention.

[039] Fig. 12 is a block diagram showing an exemplary architectural arrangement of clients, servers, and external services, according to an embodiment of an embodiment of the invention.

[040] Fig. 13 is a block diagram showing an exemplary system architecture utilizing a single quality analysis module operated by a media source, according to an embodiment of the invention.

[041] Fig. 14 is a block diagram showing an exemplary system architecture utilizing multiple quality analysis modules, according to an embodiment of the invention.

[042] Fig. 15 is a method flow diagram illustrating an exemplary method for quality analysis using event-based media playback across a plurality of devices.

DETAILED DESCRIPTION

[043] The term “Unicast” may be used to refer to a type of Internet Protocol transmission in which information is sent from only one sender to only one receiver. In other words, unicast transmission is a one-to-one node transmission between two

nodes only. In unicasting each outgoing packet has a unicast destination address, which means it is destined for a particular destination that has that address. All other destinations that may hear that packet ignore the packet, if the packet's destination address is not the same as that destination's address.

[044] As used herein, "broadcast messaging" or "broadcasting" refers to a type of Internet Protocol transmission in which information is sent from just one computer, but is received by all the computers connected on the network. This would mean that every time a computer or a node transmits a "broadcast" packet, all the other computers could receive that information packet.

[045] As used herein, "multicast messaging" or "multicasting" refers to a type of Internet Protocol transmission or communication in which there may be more than one sender and the information sent is meant for a set of receivers that have joined a multicast group, the set of receivers possibly being a subset of all the receivers. In multicasting, each multicast packet is addressed to a multicast address. This address is a group address. Any destination can subscribe to the address and therefore can listen and receive packets sent to the multicast address that it subscribed to. The benefit of multicasting is that a single multicast packet sent can be received by multiple destinations. This saves network traffic if the same packet needs to be sent to multiple destinations. When the same data needs to be sent to multiple IP destinations generally, broadcasting or multicasting, rather than unicasting, provides the most efficient use of the network.

[046] In this description the terms broadcast and multicast may be used. In both broadcasting and multicasting, when messages are sent, they are received by multiple destinations. Therefore, as used herein, the terms broadcast and multicast may be used interchangeably to refer to one packet being received by multiple destinations. In some cases, this description only refers to the media being sent or transmitted without specifying whether it is broadcast, multicast or unicast. In such case, it means any one of these methods may be used for sending or transmitting the media.

[047] As used herein, the terms "message" and "packet" are often used and may be used interchangeably. A packet is a data set to be sent or received on an Internet

Protocol (“IP”) network. The packet may or may not be the same as an “IP packet”. The term “message”, as used herein, refers to the logical information contained in such a packet.

[048] As used herein, the “segment” may also be used to refer to a data set. A data set is a set of bytes of data. Data may be any type of data, including media or control or informational data. In this description the term data and packet may also be used interchangeable depending on context. “Packet” may refer to a data set and data refers to data in general.

Description of the Embodiments of the Invention

[049] Numerous alternative embodiments are disclosed herein; it should be understood that these embodiments are presented for illustrative purposes only. The described embodiments are not intended to be limiting in any sense. In general, embodiments are described in sufficient detail to enable those skilled in the art to practice one or more of the inventions, and it is to be understood that other embodiments may be utilized and that structural, logical, software, electrical and other changes may be made without departing from the scope of what is disclosed.

[050] According to an embodiment of the invention, in order to broadcast media over a Wi-Fi network, it is first necessary to recognize that broadcast or multicast media will not be received at all destinations uniformly. Some destinations may receive a multicast “packet” (referring to a data set to be sent or received on an Internet Protocol (“IP”) network, while others may not. The packet may or may not be the same as an “IP packet”. The term “message”, as used herein, refers to the logical information contained in such a packet; may also be referred to interchangeably as a “message”, or “segment”).

[051] IP networks were first designed to operate over wired networks. By design, the packet communications on these networks were “best effort”. This means any packet transmitted on the network may not be received by the intended destination. This is most often due to a collision, where another device starts to communicate at the same moment as the device of interest, thereby causing a collision. Another method of loss would be the devices in the network path, such as routers, simply dropping the packet,

for example due to the lack of buffer space. Other reasons for loss could be that the wired line is simply noisy and the packet transmission got corrupted, though this is rare for the wired case vs. the wireless case.

[052] In all these wired situations it is generally the case that, if the transmission (for example, a multicast message), was received by one device on a subnet or wire, all the other devices on the same wire or subnet would also receive the transmission correctly. This is because in the wired case, the noise or interference situation of a device on one part of the wire is not so different from the noise situation at another part of the wire. If the wired devices are connected via a switch rather than a hub, the same issues are true, and the amount of noise or interference is minimal.

[053] In Wi-Fi the differences in receipt of Wi-Fi traffic at each Wi-Fi device in a subnet is substantial. Therefore, it is necessary to account for any latency or delay when rendering media at Wi-Fi devices, as described below.

[054] According to an embodiment of the invention all devices (i.e., a source device 104 and various destination devices 106 and 106') (see Figs. 1 and 3) may be networked together on a local network 120. This is typically an IP network and may be a wired or a wireless (e.g. Wi-Fi) network. This local network may be further connected to the Internet.

[055] In many media systems it is desirable to send the media to multiple playback devices and have each playback device render the media in phase. For example, it is desirable to send the left channel of stereo audio media to the left audio playback device and the right channel of the stereo media to the right audio playback device and to have both these devices play the media correctly in phase.

[056] Fig. 1 shows such a system with two digital audio subsystems, a first subsystem 106 and a second subsystem 106'. Each renders the same or related audio data. For example, each audio subsystem may be receiving media from a media file 222 on a network. Each system (that is, audio systems 106 and 106') comprises a central processing unit (CPU) and a digital-to-analog converter. Each system 106, 106' renders audio output 112 and 112' via DACs. In this case rendered output waves 220 and 220'

need to be in audio phase as shown in Fig. 1. To be in audio phase, the rendered waves 220 and 220' need to have the correct sounds (frequency spectrum) playing at the correct time (phase offset). For example, if the media contains a left channel that rings a bell 1 minute into the media and the right channel plays a drum beat at the same time, and the device 106 is to play the left channel and the device 106' is to play the right channel. Then the devices are in phase, if 1 minute into media playback, device 106 renders the bell sound and device 106' renders the drum beat.

[057] If rendered waves 220 and 220' are not in phase, then users may hear a beat frequency that is related to the difference in frequency between the two waves 220 and 220'. Furthermore, over time, the two audio outputs may differ to a continually increasing extent. For instance, in the example used previously, if the second subsystem 106' is off by +50 parts per million (ppm), and a 3-minute song ends with a drum beat, the second subsystem 106' will play the final drum beat 9 milliseconds later than the first subsystem 106. After ten such songs the difference will be 90 milliseconds, which will be very noticeable.

[058] Therefore, when multiple audio devices 106 and 106' are playing the same media, it is necessary to adjust and ensure that the rendering clock on each system has the same phase offset and frequency.

[059] Fig. 2 shows a typical digital system 106 for playing audio in more detail. The CPU 114 sends audio samples 110 to the DAC 108 which are rendered by the DAC 108, converting the digital samples into analog signals 112. The rate at which the DAC converts digital samples into analog signal levels is called the output sample rate and the output sample rate typically matches the rate at which the audio samples being sent from the CPU 114 at which they were sampled. The exact output sample rate is determined by a DAC clock subsystem that is driving the DAC. The accuracy of this clock subsystem will impact the accuracy of the output sample rate and therefore the accuracy of the rendering of audio by this system. This clock subsystem may use a clock originating from the CPU 114 or from an external source 105.

[060] A CPU clock crystal 102 on a typical CPU 114 will be the basis of the CPU clock generated internally by CPU 114. This CPU clock will then be used for all CPU timing

activity. Some CPUs may generate many different clock signals internal to CPU 114, based on this CPU clock. CPU 114 may also have many clock peripherals and clock registers 136, based on the CPU clock that can be used for various timing related activities. For example, a clock peripheral may be configured to interrupt the CPU periodically every 100 milliseconds. Since this clock is based originally on CPU crystal 102, the accuracy of this period will depend on the accuracy of CPU crystal 102. Typically, a program running on CPU 114 can also read a clock register 136 which will show the number of clock counts CPU 114 has counted since CPU 114 was powered up and reset. These clock counts will increment at a rate that is related to CPU crystal 102. This clock may be used to drive the DAC output sample rate and the rate at which audio samples are provided to the DAC.

[061] In some embodiments, system 106 may further comprise a separate audio clock 105, with its own independent crystal 103, for sending an audio clock signal 116 to CPU 114 and DAC 108 for managing the timing of playback of audio signals sent from CPU 114 to DAC 108, and for generating audio output 112 from such audio signals via the DAC 108.

[062] Alternate embodiments may use various combinations of external and internal clock sources to drive the DAC sample rate.

[063] In media systems, such as that shown in Fig. 1, where it is necessary to send the media to multiple playback devices and to have each playback device render the media in phase, the media needs to be marked with some time reference information and each device needs to play this media according to this time information. This means each device needs to use the same time reference so that its rendering activity is time aligned.

[064] Fig. 3 illustrates a common clock based approach to time referencing as described previously. As illustrated, a source device 104 and one or more destination devices 106, 106' may be connected by a network 120. Source device 104 has a local clock C 135, the "common" source clock, and each destination device 106, 106' also contains a local clock designated as D_1 136 for the first device 106 and D_x 136' for the xth device 106'. Source clock 135 is referred to as a common source clock because its

clock value is sent to all the destinations and is used as a standard clock in common to all the devices. Source device **104** periodically sends “clock” messages to each destination device **106, 106'** containing the latest common source clock value from the “common” clock C of source device **104** that was read prior to sending the message. Clock messages being sent to the 1st device at period n with a clock value are marked as C_{I_n} **250**, and clock messages being sent to the x th device at period n with a clock value is marked as C_{x_n} **252**. When each destination device **106, 106'** receives a clock message it records the latest clock value it received C_{I_n} or C_{x_n} as **254** and **254'**. When each destination **106, 106'** receives a clock message it also records the corresponding local clock value, D_{I_n} or D_{x_n} , that goes with the C_{I_n} or C_{x_n} common clock value it received. There is a delay from the moment of receipt of the clock message to when the local clock associated with it is recorded. This “recording” delay may vary from clock message to clock message and is defined as a recording jitter R . This change in recording delay may be due to the network adapter used for the messaging and changing response time of the software on the destination to a packet receipt.

[**065**] **Fig. 4** shows a timeline of the message transactions. Source device **104** sends the n th clock messages, with clock values C_{I_n} **250** to first device **106** and C_{x_n} **252** to x th device **106'**. The $n+1$ th message and so on are similar. Each clock message will take a certain amount of time (transport time) to get from a source **104** to each destination **106-106'**.

[**066**] The time for the n th message to get to the x th device is T_{x_n} . The transport time to each destination may be different due to network packet transmission issues. This difference will change over time and from device to device. These changes in T_x are referred to as transport jitter J_x at device x .

[**067**] Based on the information in each clock message C_{x_n} and the corresponding local clock value D_{x_n} recorded, each destination x **106,106'** may compute information to adjust its local clock D_x **136, 136'** to match common source clock C **135**. Destinations **106, 106'** may adjust local clocks' D_I, D_x **136, 136'** phases (counts) P_x to match a best estimate of the current phase (count) P_c of the source clock C **135**. Similarly,

destinations **106**, **106'** may adjust local clocks' D_1 , D_x **136**, **136'** frequencies F_x to match a best estimate of current frequency F_c of common source clock **C 135**.

[**068**] Exemplary calculations for performing these steps may be as follows:

- Cx_n : n th Common source clock value sent to device x
- TA_x : Average estimated transit time to device x
- RA_x : Average estimated recording time at device x
- J_x : Max transit time deviation from average TA_x
- R_x : Max recording time deviation from average
- Tx_n : Transport time of n th message sent to device x
- Dx_n : Device x 's clock value at n th clock message
- Fx_n : Device x 's new local clock Frequency
- Px_n : Device x 's new local clock Phase/Count
- $Cx'_n = Cx_n + Tx_n + Rx_n$: Estimate Common clock n
- $Cx'_{n+1} = Cx_{n+1} + Tx_{n+1} + Rx_{n+1}$: Est Common clock $n+1$
- $Tx_n = Ta_x +/- J_x$: Transport Time n
- $Tx_{n+1} = Ta_x +/- J_x$: Transport Time $n+1$
- $Rx_n = Ra_x +/- Rx$: Recording Time n
- $Rx_{n+1} = Ra_x +/- Rx$: Recording Time $n+1$
- $Ax_n = (Dx_{n+1}-Dx_n) - (Cx'_{n+1}-Cx'_n)$: Frequency Adjustment
- $Ax_n = (Dx_{n+1}-Dx_n) - (Cx_{n+1}-Cx_n) +/- 2*J_x +/- 2*R_x$
- $Fx_n = Fx_{n-1} - Ax_n$: New Frequency
- $Fx_n = Fx_{n-1} + (Cx_{n+1} - Cx_n) - (Dx_{n+1} - Dx_n) +/- 2*J_x +/- 2*R_x$

- $Px_n = Cx'_n = Cx_n + Ta_x +/- Jx +/- Rx$: Phase Offset

[069] Estimating the transport time Tx is critical for this system. One common way of doing this is to measure round trip time from source to destination by sending a message from source 104 to destination Dl, Dx 106, 106' and having destination Dl, Dx 106, 106' acknowledge this message. The total time from sending an outgoing message to receiving an incoming acknowledge message is the round trip time. Halving this time provides an estimate of outgoing transit time. If this is done many times and filtered, the filtered result Ta_x can be used as the average transit time from a source to destination Dx . The actual transit time Tx_n for the nth message will be $= Ta_x +/- Jx_n$, where Jx_n is the jitter—the deviation from the average for this nth message. Jx_n can be estimated using the standard deviation of the Tx times measured.

[070] In this scheme each destination device 106, 106', uses the common source clock 135 information to adjust its local clock 136, 136' values and clock rate to match that of common source clock 135. That is, common source clock 135 is a “global” clock used in the system and all destination clocks are aligned to this. The media is then rendered at each device using local clocks 136, 136'.

[071] The precision of this system may be limited because transport jitter may impact both the frequency and phase calculations. This may be mitigated somewhat by filtering the parameters used in the calculation over a period of time, as mentioned above. The rendering of the media is done by destination devices 106, 106'; since clocks associated with these devices are used as a basis for media rendering, this means the phase accuracy of media rendering is affected by transport time jitter. If transport time jitter Jx is +/- 1 to 2 milliseconds, as it can be on a Wi-Fi network, then the maximum phase accuracy that can be achieved is limited to this range.

[072] A further issue with this system is that virtual clock time only increments at intervals of received messages. This can be addressed by using a local clock to interpolate time in between these message intervals. The problem is that each device's local clock may be slightly different from the others, and therefore interpolated virtual clocks may jump forward or move slightly backwards at each adjustment made as a

result of received messages. This may cause the media rendering to jump forward or backwards by small amounts from time to time.

[073] A further issue is that in many systems a common global clock is not available or even if it is available, it is not accurate enough for synchronization purposes. For example, the source devices local clock may be accessed through a programming API, however since the caller program is usually running in a multitasking operating system that may have delays or task swaps during the API call, the local clock time will be incorrect by that time. For example, the caller program may call the local clock API and it may read the hardware clock value, then before the function returns the current program thread is tasked swapped and returns only in the next program thread time slice. This means the hardware clock value returned is now out of date by the time slice period. Most common operating systems can have a time slice period of up to 25-100 milliseconds, so the hardware clock value may be out of date by many milliseconds. This is the case for many general purpose source devices such as Smartphones or notebooks. By contrast the destination devices used in this invention are special purpose devices and therefore the software operates at a lower level with much better local clock read accuracy.

[074] Therefore, various embodiments of the invention may be designed with the goal of not using or requiring the ability to read the source devices local clock accurately.

[075] The disclosed configuration renders media using each device's local rendering clocks only. The destination devices local clock referred to here is the clock that is used as the base for the rate (sample rate) at which media samples are fed to the DAC (digital to analog converter) to convert (render) the digital media samples into audio or video signals. This local clock may be a hardware clock or it may be a virtual clock, a software object, such as an interrupt service routine, that may be assisted by a hardware clock, feeding samples to the DAC for conversion to audio or video signals.

[076] These destination clocks are continuous and smooth in how they increment and therefore smooth in how they render the media. However, it may be necessary to adjust for the potential differences in device clocks. One embodiment addresses this

adjustment by breaking into two problems. The first problem is detecting the frequency differences. The second problem is adjusting for the differences. To detect the difference one embodiment uses a common event-based technique rather than a common clock.

[077] Fig. 5 is an illustration of the basic elements of an example common event-based system. The system consists of a source 104 and one or more destination devices 106, 106' connected by a network 120. The source device has two elements, a common event source E 350 and a synchronization calculation manager (synchronization manager) S 352. Common event source E 350 generates event messages on the network that are received at a common time, the same time, at all the destination devices. An example of a common event message E_n 358 is a multicast or broadcast message received simultaneously by all destination devices 106, 106'. Note a multicast or broadcast message is put on the communication channel by one device, the source device and received by all destination devices. The message is actually communicated on the communication channel usually by electrical means with either an electrical or RF signal travelling close to the speed of light. Therefore, for example the last bit of the message is received by all destination devices at a time that is only different by the distance times the speed of light, which is almost instantaneous. Another example of a common event message is a beacon message in a network using for example the 802.11 (Wi-Fi) network protocol or short-wavelength UHF radio waves in the ISM band from 2.4 to 2.485 GHz such as Bluetooth™.

[078] In one embodiment, any series of events that are received by all the destination devices, and where each event is uniquely identifiable and where each event is received by all the destination devices as the same time, may be used as the common event described here. In one embodiment, the synchronization manager S 352, is the source of such common events.

[079] The synchronization calculation manager S 352 may reside on any computing device on the network 120 including on a destination device 106, 106'.

[080] Each destination device x (106, 106') has a local clock D_x (136, 136') that is used as the basis for rendering media by the device.

[081] Fig. 6 shows a timeline for the activities and messages in the system. The event source E 350 generates event message, where the n th event is marked as E_n 358, generated at time t_n . The event E_n 358, is identified by an even number n , which is unique to each event. The event number, n , could just be a sequentially incrementing number generated by the Synchronization Manager S 352, from the time the system was turned on, or it could be a time stamp value. If the later, this is only used as a unique number, the time value is Not used as an indicator of time. Any other form of generating a unique event number is fine. On receipt of each event message E_n each destination x records the current value of its local clock Dx 136 as Dx_n . As in the common clock case, there is a delay from the moment of receipt of the event message to when the local clock associated with it is recorded. This “recording” delay may vary from event message to event message and is defined as a recording jitter R .

[082] Each destination device x , on receipt of an event message n , sends an event Acknowledge message $AK(Dx_n)$ 354, 354', for the n th event, with the value Dx_n , that was recorded on receipt of the event n , and the unique event number n , to the synchronization calculation manager S 352. The synchronization calculation manager receives all event Acknowledge messages $AK(Dx_n)$ 354, 354', with Dx_n values in them, performs calculations, and then sends back clock adjustment messages $AJ(Ax_n)$ 356, 356' to each device x with Adjustment information Ax_n in it. The calculations performed are shown below:

- E_{x_n} : n th Common event message sent to device x ;
- T_{x_n} : Transport time of n th event sent to device x ;
- D_{x_n} : Device x 's clock value at n th event message;
- F_{x_n} : Device x 's new local clock Frequency;
- P_{x_n} : Device x 's new local clock Phase/Count;
- $Q_{x_0} = D_{x_0} - D_{I_0} +/- 2 * R_x$: Reference (Initial) Clock Phase vs Device 1
- $Q_{x_n} = D_{x_n} - D_{I_n} +/- 2 * R_x$: n th Clock Phase;

- $Qf_n = F(Qx_n)$: Filter function for the nth Clock Phase;
- $ex_n = (Qf_n - Qf_o) +/- 4 * Rx$: phase error (change);
- $kx_n = T * ex_n$: error * Transfer function;
- $Fx_n = Fx_o + kx_n +/- T * 4 * Rx$: New Frequency;
- $PFx_n = ((Fx_n / Fx_{n-1}) - 1) * 100$: Percent New Frequency;
- $Px_n = Dx_n - D1_n +/- 2 * Rx$: Phase offset; and
- $Ax_n = (PFx_n, Px_n)$: adjustment information.

[083] In this common event system, one device's clock, the first destination device, device 1, is used as the phase reference clock. With these calculations the synchronization module computes a phase offset (local clock value) and a percent frequency (local clock rate) adjustment for each destination device x, sends this adjustment information to the destination x and asks it to make adjustments so that the local clock at each destination device x will match that of the local clock of destination device 1.

[084] For example, ignoring the jitter, if between common even event 1, E1, and event 2, E2, the first destination devices local clock increments 100 counts and destination device x increments 101 counts, then device x is running fast with respect to destination device 1 and its clock rate needs to be decreased by 1 count out of 101. Furthermore, if the 1st destination devices, local clock was 2500 at Event 1, E1, and destination x local clock was 3000 at Event 1, E1, then destination x's local clock needs to be adjusted to 2500 to match the phase of the 1st destination device.

[085] While this embodiment defines the frequency adjustment as a percent of frequency, other embodiments may define the frequency adjustment in other forms including an absolute new frequency or the number of samples to add or drop. All of these forms are referred to as frequency adjustment for the purpose of this specification. Also the use of the word frequency refers to a clock rate and is related

and may refer to both the audio sample crystal rate and the sample output rate. Generally, the sample output rate is a multiple of the audio sample crystal rate.

[086] The phase adjustment refers to the adjustment of a clock value and the clock value may be for a clock incrementing at the audio crystal rate or the sample output clock output rate or some other counter value related to the sample output clock.

[087] A key issue in this common event system is that the acknowledge messages 354, 354' and adjustment messages 356, 356' may not arrive at a predictable time at the receiving end, as they are being sent over an IP network. Each acknowledge message includes the destination device number.

[088] Therefore, the synchronization module 352, cannot group acknowledge messages 354, 354' for the same event by time of arrival. For example, some acknowledge messages for Event 1 may arrive at the synchronization Module 352, after acknowledge messages for Event 2 arrive. Therefore, acknowledge messages are grouped into sets of event acknowledge messages based on the unique event number.

[089] To do this, the synchronization module 352 can associate all acknowledge messages sent from the set of destination devices for each unique event. Therefore, the synchronization module marks each event message with a number, n , which is unique over time for the lifetime of the system. This may simply be an event number that increments with each event. All the destination devices, include this unique event number in the acknowledge messages AK 354, 354'. Whenever an acknowledge messages AK 354, 354' is received at the synchronization Module 352, the acknowledge messages are placed in a collection of acknowledge messages $\{ AK(D_{ab}), .. AK(D_{1n}) .. AK(D_{xn}), AK(D_{1n+1}) .. etc \}$. Then this collection is searched to find a subset of all the acknowledge messages for a particular event number n , $\{ AK(D_{1n}) .. AK(D_{xn}) \}$. Then the phase change Q_{xn} with respect to device 1, is calculated using the values from this subset as shown in the calculations above. The values in this subset may be further filtered prior to use.

[090] In an alternate embodiment the event messages may come from an outside source such as by using the beacon messages of the WiFi system. In this case the time

value in the beacon messages may be used as a unique event number. Note the time value is not used as a time value, but only as a unique event number

[091] Fig. 7 identifies some important and critical differences between the common clock and common event methods described herein. The upper plot 450 shows the net effect of the common clock method. In this method source's 104 clock, a common clock, is a "global" clock 454 used by the system. This clock is used by each destination D_1 106 through D_x 106', which estimates a common source clock time to adjust its local clock by. As mentioned above, the accuracy of this setting is affected by transport latency L_1 458 and L_x 460. Each destination device D_1 106 and D_x 106' independently estimates a common clock time, so phase difference P 462 of these clocks will be highly dependent on these latencies. Since transport latencies vary from message to message, which is referred to as transport jitter, this means destination devices clocks' (D_1 136 and D_x 136') clock settings have accuracies that are subject to transport jitter. Specifically, this means the difference in the clocks, the phase difference, is subject to the maximum message transport jitter J_x . Keeping phase accuracy in rendering media on both devices D_1 106 and D_x 106' is desirable. The suggests it would be best to avoid having transport jitter affect phase accuracy.

[092] Overall, the common clock method aligns all clocks with the common clock at the source, the adjustment calculations are done independently at each destination, and the accuracy is dependent on recording accuracy R_x and transport jitter J_x .

[093] The lower plot 452 shows the common event approach used in various embodiments of the invention. In this approach clock D_1 of first destination device 106 becomes a reference, "global" clock 456, used in the system. Additional destination devices 106' adjust their clocks D_x to the global clock of D_1 106. Phase differences P 466 of these clocks are unaffected by transport latencies and only related by how accurately they record a common event at the point of receipt. Transport latency L_1 464 is only a factor in projecting global clock 456 back to source 104. In an embodiment of the invention source 104 adjusts its clock to match destination clock D_1 106 if needed. In this embodiment there is no need for a source clock or such an adjustment.

[094] Overall, the common event approach aligns all clocks with one of the destination clocks, and the accuracy is dependent on recording accuracy R_x only. Since transport jitter J_x tends to be many times larger than recording accuracy R_x , as transport jitter is affected by all the devices and processes involved in the transport of the message (whereas the recording accuracy is only dependent on and local to the destination hardware and its software). Transport jitter can be many milliseconds, whereas recording jitter is usually less than a few hundred microseconds. So the common event approach, being dependent only on recording accuracy, is a better approach to providing high levels of phase synchronization accuracy with less effort and complexity.

[095] Fig 8 shows an exaggerated view of the overall effect of the common event approach. The upper waveform 220 is the output of the DAC from device D_I 106 and the lower waveform 220' is the output from the DAC from device D_x 106'. The vertical lines on both plots show the clock ticks of their respective rendering clocks (DAC sample rate output clock). Also plotted on the vertical lines are the sample data that would be rendered on each clock tick. In Fig. 8, the lower waveform D_x has a much slower clock tick than the upper waveform and therefore the audio samples are rendered over a longer time period than in device D_I . This Figure also shows two common events E_n and E_{n+1} . As can be seen the amount of clock ticks that the lower waveform from D_I has incremented is less than the amount of clock ticks that have been incremented in the upper waveform 220. The phase at time E_n is the difference in clock count between the two devices at time E_n . The phase at time E_{n+1} is also this difference. Since the clock rates are different, it can be seen that the phase at event E_n , is going to be different from that at event E_{n+1} . The common event calculations and adjustment mentioned above will correct for this and increase the clock rate of the lower waveform 220' until its clock rate matches that of the upper waveform 220. At that point the two waveforms would be rendered similarly and will be rendered in phase.

[096] The adjustment of the local clock rate can be done in a number of ways. The common approach is to literally adjust the clock rate of the rendering clock. Usually this requires some sort of hardware subsystem that can generate a clock that is

adjustable. An alternative approach is to leave the rendering clock alone and to adjust the media data instead. This approach is to convert the sample rate, do a sample rate conversion, to compensate for the clock rate difference. If a 1KHz audio signal were sampled at 44.1 KHz and was then rendered by a 44.1 KHz clock the audio signal rendered will be an accurate representation of the original. If the rendering clock is 44 KHz instead, then the 1KHz audio signal will be rendered at a slightly lower tone and will not be an accurate representation of the original. If the audio data were now sample rate converted from 44.1 KHz to 44 KHz and rendered using the 44 KHz rendering clock, the 1KHz audio signal rendered will now again be an accurate representation of the original.

[097] A preferred embodiment of the invention uses the latter sample rate conversion approach. When frequency adjustment messages are received by each destination, instead of adjusting the rendering clock, each destination performs a sample rate conversion on the data stream, increasing or decreasing the sample rate of the data. This has the same net effect as adjusting the rendering clock.

[098] Typically, the difference in frequency is related to the accuracy of clock crystals which are specified in PPM, parts per million. A 100 PPM crystal is accurate to < 0.01% or 1 part in 10,000. So the sample rate conversion required here is a small adjustment typically 1 sample in 10,000 samples. So the adjustment can be accomplished by adding or dropping a sample every so often.

[099] Fig 9 illustrates the algorithm described previously in the form of a control system. This shows several devices marked as D_1 106 through D_x 106'. Each destination device, excluding a first device D_1 106, implements a software phase lock loop algorithm to lock its phase to the clock phase of device D_1 106. Associated with each destination device D_x 106' is a phase comparator 650' that compares the phase of its output clock D_{x_n} 654' to the reference clock D_1 652. The phase difference with respect to the reference clock e_{x-1} 656 is then scaled to produce a clock frequency adjustment A_x 700'. This adjustment then causes the clock generator 702' at the destination 106' to adjust its clock frequency. In this embodiment of the system the

phase detector 650' and gain/scale 658' reside on the synchronization calculation manager 352. The clock generator 702' resides on the destination device 106'.

Additional Consideration

[100] Headings of sections provided in this patent application and the title of this patent application are for convenience only, and are not to be taken as limiting the disclosure in any way.

[101] Devices that are in communication with each other need not be in continuous communication with each other, unless expressly specified otherwise. In addition, devices that are in communication with each other may communicate directly or indirectly through one or more intermediaries, logical or physical.

[102] A description of an embodiment with several components in communication with each other does not imply that all such components are required. To the contrary, a variety of optional components may be described to illustrate a wide variety of possible embodiments of one or more of the inventions and in order to more fully illustrate one or more aspects of the inventions. Similarly, although process steps, method steps, algorithms or the like may be described in a sequential order, such processes, methods and algorithms may generally be configured to work in alternate orders, unless specifically stated to the contrary. In other words, any sequence or order of steps that may be described in this patent application does not, in and of itself, indicate a requirement that the steps be performed in that order. The steps of described processes may be performed in any order practical. Further, some steps may be performed simultaneously despite being described or implied as occurring non-simultaneously (e.g., because one step is described after the other step). Moreover, the illustration of a process by its depiction in a drawing does not imply that the illustrated process is exclusive of other variations and modifications thereto, does not imply that the illustrated process or any of its steps are necessary to one or more of the invention(s), and does not imply that the illustrated process is preferred. Also, steps are generally described once per embodiment, but this does not mean they must occur once, or that they may only occur once each time a process, method, or algorithm is carried out or executed. Some steps may be omitted in some embodiments or some

occurrences, or some steps may be executed more than once in a given embodiment or occurrence.

[103] When a single device or article is described, it will be readily apparent that more than one device or article may be used in place of a single device or article. Similarly, where more than one device or article is described, it will be readily apparent that a single device or article may be used in place of the more than one device or article.

[104] The functionality or the features of a device may be alternatively embodied by one or more other devices that are not explicitly described as having such functionality or features. Thus, other embodiments of one or more of the inventions need not include the device itself.

[105] Techniques and mechanisms described or referenced herein will sometimes be described in singular form for clarity. However, it should be noted that particular embodiments include multiple iterations of a technique or multiple instantiations of a mechanism unless noted otherwise. Process descriptions or blocks in figures should be understood as representing modules, segments, or portions of code which include one or more executable instructions for implementing specific logical functions or steps in the process. Alternate implementations are included within the scope of embodiments of the present invention in which, for example, functions may be executed out of order from that shown or discussed, including substantially concurrently or in reverse order, depending on the functionality involved, as would be understood by those having ordinary skill in the art.

[106] Generally, the techniques disclosed herein may be implemented on hardware or a combination of software and hardware. For example, they may be implemented in an operating system kernel, in a separate user process, in a library package bound into network applications, on a specially constructed machine, on an application-specific integrated circuit (ASIC), or on a network interface card.

[107] Software/hardware hybrid implementations of at least some of the embodiments disclosed herein may be implemented on a programmable network-

resident machine (which should be understood to include intermittently connected network-aware machines) selectively activated or reconfigured by a computer program stored in memory. Such network devices may have multiple network interfaces that may be configured or designed to utilize different types of network communication protocols. A general architecture for some of these machines may be disclosed herein in order to illustrate one or more exemplary means by which a given unit of functionality may be implemented. According to specific embodiments, at least some of the features or functionalities of the various embodiments disclosed herein may be implemented on one or more general-purpose computers associated with one or more networks, such as for example an end-user computer system, a client computer, a network server or other server system, a mobile computing device (e.g., tablet computing device, mobile phone, smartphone, laptop, and the like), a consumer electronic device, a music player, or any other suitable electronic device, router, switch, or the like, or any combination thereof. In at least some embodiments, at least some of the features or functionalities of the various embodiments disclosed herein may be implemented in one or more virtualized computing environments (e.g., network computing clouds, virtual machines hosted on one or more physical computing machines, or the like). Moreover, in some embodiments one or more aspects, or all aspects, of the invention may optionally be implemented via a specially programmed chip (for instance, an application specific integrated circuit, or ASIC, or an erasable programmable read only memory, or EPROM), or via some other hardware-only approach known in the art.

Description of the Exemplary Hardware Embodiments

[108] Referring now to **Fig. 10**, there is shown a block diagram depicting an exemplary computing device **1200** suitable for implementing at least a portion of the features or functionalities disclosed herein. Computing device **1200** may be, for example, any one of the computing machines listed in the previous paragraph, or indeed any other electronic device capable of executing software- or hardware-based instructions according to one or more programs stored in memory. Computing device **1200** may be adapted to communicate with a plurality of other computing devices, such as clients or servers, over communications networks such as a wide area network

a metropolitan area network, a local area network, a wireless network, the Internet, or any other network, using known protocols for such communication, whether wireless or wired.

[109] In one embodiment, computing device 1200 includes one or more central processing units (CPU) 1202, one or more interfaces 1210, and one or more busses 1206 (such as a peripheral component interconnect (PCI) bus). When acting under the control of appropriate software or firmware, CPU 1202 may be responsible for implementing specific functions associated with the functions of a specifically configured computing device or machine. For example, in at least one embodiment, a computing device 1200 may be configured or designed to function as a server system utilizing CPU 1202, local memory 1201 and/or remote memory 1220, and interfaces) 1210. In at least one embodiment, CPU 1202 may be caused to perform one or more of the different types of functions and/or operations under the control of software modules or components, which for example, may include an operating system and any appropriate applications software, drivers, and the like.

[110] CPU 1202 may include one or more processors 1203 such as, for example, a processor from one of the Intel, ARM, Qualcomm, and AMD families of microprocessors. In some embodiments, processors 1203 may include specially designed hardware such as application-specific integrated circuits (ASICs), electrically erasable programmable read-only memories (EEPROMs), field-programmable gate arrays (FPGAs), and so forth, for controlling operations of computing device 1200. In a specific embodiment, a local memory 1201 (such as non-volatile random access memory (RAM) and/or read-only memory (ROM), including for example one or more levels of cached memory) may also form part of CPU 1202. However, there are many different ways in which memory may be coupled to system 1200. Memory 1201 may be used for a variety of purposes such as, for example, caching and/or storing data, programming instructions, and the like.

[111] As used herein, the term “processor” is not limited merely to those integrated circuits referred to in the art as a processor, a mobile processor, or a microprocessor, but broadly refers to a microcontroller, a microcomputer, a programmable logic

controller, an application-specific integrated circuit, and any other programmable circuit.

[112] In one embodiment, interfaces **1210** are provided as network interface cards (NICs). Generally, NICs control the sending and receiving of data packets over a computer network; other types of interfaces **1210** may for example support other peripherals used with computing device **1200**. Among the interfaces that may be provided are Ethernet interfaces, frame relay interfaces, cable interfaces, DSL interfaces, token ring interfaces, graphics interfaces, and the like. In addition, various types of interfaces may be provided such as, for example, universal serial bus (USB), Serial, Ethernet, FIREWIRE™, PCI, parallel, radio frequency (RF), BLUETOOTH™, near-field communications (e.g., using near-field magnetics), 802.11 (WiFi), frame relay, TCP/IP, ISDN, fast Ethernet interfaces, Gigabit Ethernet interfaces, asynchronous transfer mode (ATM) interfaces, high-speed serial interface (HSSI) interfaces, Point of Sale (POS) interfaces, fiber data distributed interfaces (FDDIs), and the like. Generally, such interfaces **1210** may include ports appropriate for communication with appropriate media. In some cases, they may also include an independent processor and, in some instances, volatile and/or non-volatile memory (e.g., RAM).

[113] Although the system shown in **Fig. 10** illustrates one specific architecture for a computing device **1200** for implementing one or more of the inventions described herein, it is by no means the only device architecture on which at least a portion of the features and techniques described herein may be implemented. For example, architectures having one or any number of processors **1203** may be used, and such processors **1203** may be present in a single device or distributed among any number of devices. In one embodiment, a single processor **1203** handles communications as well as routing computations, while in other embodiments a separate dedicated communications processor may be provided. In various embodiments, different types of features or functionalities may be implemented in a system according to the invention that includes a client device (such as a tablet device or smartphone running client software) and server systems (such as a server system described in more detail below).

[114] Regardless of network device configuration, the system of the present invention may employ one or more memories or memory modules (such as, for example, remote memory block 1220 and local memory 1201) configured to store data, program instructions for the general-purpose network operations, or other information relating to the functionality of the embodiments described herein (or any combinations of the above). Program instructions may control execution of or comprise an operating system and/or one or more applications, for example. Memory 1220 or memories 1201, 1220 may also be configured to store data structures, configuration data, encryption data, historical system operations information, or any other specific or generic non-program information described herein.

[115] Because such information and program instructions may be employed to implement one or more systems or methods described herein, at least some network device embodiments may include nontransitory machine-readable storage media, which, for example, may be configured or designed to store program instructions, state information, and the like for performing various operations described herein. Examples of such nontransitory machine-readable storage media include, but are not limited to, magnetic media such as hard disks, floppy disks, and magnetic tape; optical media such as CD-ROM disks; magneto-optical media such as optical disks, and hardware devices that are specially configured to store and perform program instructions, such as read-only memory devices (ROM), flash memory, solid state drives, memristor memory, random access memory (RAM), and the like. Examples of program instructions include both object code, such as may be produced by a compiler, machine code, such as may be produced by an assembler or a linker, byte code, such as may be generated by for example a JAVA™ compiler and may be executed using a JAVA™ virtual machine or equivalent, or files containing higher level code that may be executed by the computer using an interpreter (for example, scripts written in Python, Perl, Ruby, Groovy, or any other scripting language).

[116] In some embodiments, systems according to the present invention may be implemented on a standalone computing system. Referring now to Fig. 11, there is shown a block diagram depicting a typical exemplary architecture of one or more

embodiments or components thereof on a standalone computing system. Computing device **1300** includes processors **1310** that may run software that carry out one or more functions or applications of embodiments of the invention, such as for example a client application **1330**. Processors **1310** may carry out computing instructions under control of an operating system **1320** such as, for example, a version of Microsoft's WINDOWS™ operating system, Apple's Mac OS/X or iOS operating systems, some variety of the Linux operating system, Google's ANDROID™ operating system, or the like. In many cases, one or more shared services **1325** may be operable in system **1300**, and may be useful for providing common services to client applications **1330**. Services **1325** may for example be WINDOWS™ services, user-space common services in a Linux environment, or any other type of common service architecture used with operating system **1310**. Input devices **1370** may be of any type suitable for receiving user input, including for example a keyboard, touchscreen, microphone (for example, for voice input), mouse, touchpad, trackball, or any combination thereof. Output devices **1360** may be of any type suitable for providing output to one or more users, whether remote or local to system **1300**, and may include for example one or more screens for visual output, speakers, printers, or any combination thereof. Memory **1340** may be random-access memory having any structure and architecture known in the art, for use by processors **1310**, for example to run software. Storage devices **1350** may be any magnetic, optical, mechanical, memristor, or electrical storage device for storage of data in digital form. Examples of storage devices **1350** include flash memory, magnetic hard drive, CD-ROM, and/or the like.

[117] In some embodiments, systems of the present invention may be implemented on a distributed computing network, such as one having any number of clients and/or servers. Referring now to **Fig. 12**, there is shown a block diagram depicting an exemplary architecture for implementing at least a portion of a system according to an embodiment of the invention on a distributed computing network. According to the embodiment, any number of clients **1430** may be provided. Each client **1430** may run software for implementing client-side portions of the present invention; clients may comprise a system **1300** such as that illustrated in **Fig. 11**. In addition, any number of servers **1420** may be provided for handling requests received from one or more clients

1430. Clients 1430 and servers 1420 may communicate with one another via one or more electronic networks 1410, which may be in various embodiments any of the Internet, a wide area network, a mobile telephony network, a wireless network (such as WiFi, WiMAX, and so forth), or a local area network (or indeed any network topology known in the art; the invention does not prefer any one network topology over any other). Networks 1410 may be implemented using any known network protocols, including for example wired and/or wireless protocols.

[118] In addition, in some embodiments, servers 1420 may call external services 1470 when needed to obtain additional information, or to refer to additional data concerning a particular call. Communications with external services 1470 may take place, for example, via one or more networks 1410. In various embodiments, external services 1470 may comprise web-enabled services or functionality related to or installed on the hardware device itself. For example, in an embodiment where client applications 1330 are implemented on a smartphone or other electronic device, client applications 1330 may obtain information stored in a server system 1420 in the cloud or on an external service 1470 deployed on one or more of a particular enterprise's or user's premises.

[119] In some embodiments of the invention, clients 1430 or servers 1420 (or both) may make use of one or more specialized services or appliances that may be deployed locally or remotely across one or more networks 1410. For example, one or more databases 1440 may be used or referred to by one or more embodiments of the invention. It should be understood by one having ordinary skill in the art that databases 1440 may be arranged in a wide variety of architectures and using a wide variety of data access and manipulation means. For example, in various embodiments one or more databases 1440 may comprise a relational database system using a structured query language (SQL), while others may comprise an alternative data storage technology such as those referred to in the art as "NoSQL" (for example, Hadoop Cassandra, Google BIGTABLE™, and so forth). In some embodiments, variant database architectures such as column-oriented databases, in-memory databases, clustered databases, distributed databases, or even flat file data repositories may be used according to the invention. It will be appreciated by one having ordinary skill in

the art that any combination of known or future database technologies may be used as appropriate, unless a specific database technology or a specific arrangement of components is specified for a particular embodiment herein. Moreover, it should be appreciated that the term “database” as used herein may refer to a physical database machine, a cluster of machines acting as a single database system, or a logical database within an overall database management system. Unless a specific meaning is specified for a given use of the term “database”, it should be construed to mean any of these senses of the word, all of which are understood as a plain meaning of the term “database” by those having ordinary skill in the art.

[120] Similarly, most embodiments of the invention may make use of one or more security systems 1460 and configuration systems 1450. Security and configuration management are common information technology (IT) and web functions, and some amount of each are generally associated with any IT or web systems. It should be understood by one having ordinary skill in the art that any configuration or security subsystems known in the art now or in the future may be used in conjunction with embodiments of the invention without limitation, unless a specific security 1460 or configuration system 1450 or approach is specifically required by the description of any specific embodiment.

[121] Fig. 13 is a block diagram showing an exemplary system architecture 1500 utilizing a single quality analysis module 1503 operated by a media source 1502, according to an embodiment of the invention. A quality analysis module (“QAM”) 1503 comprises software programming instructions stored in a memory 1201 and operating on a processor 1202 of a computing device 1200 (as described previously, referring to Fig. 10), and configured to monitor, log, and analyze various network and multimedia metrics, and may be communicatively coupled to a multimedia source 1502 or destination device (as illustrated below, referring to Fig. 14) over a data communication network 1501 such as the Internet or other suitable network, to receive and process information from such devices for quality analysis purposes. It should be appreciated that multiple QAM components 1503 may be utilized, for example having a QAM 1503 on a media source device 1502, and a QAM 1503 operated by one or more media playback devices, such as in an arrangement shown below, referring again to

Fig. 14. It should be appreciated that various arrangements may be used interchangeably according to the invention. According to the embodiment, a QAM **1503** may monitor multimedia playback or network connectivity, for example by receiving metricized information from various connected devices such as (for example) a mobile user device **1504**, television **1505**, or personal computing device **1506**, and analyzing the information to determine changes in metrics (as may indicate performance loss or other changes to playback or network connectivity), or to compare a received metric value to known values to determine its overall quality (for example, a “scoring” system that may be used to determine whether a metric is within acceptable or ideal parameters). As is common in the art, various aspects of a network connection may be monitored and analyzed, such as upload and download speeds, packet loss, “ping” or packet travel times, latency, and other various metrics that are commonly measured to determine the quality of a particular network layout or a connection to a network. Additionally, a QAM **1503** utilized according to the invention may monitor various aspects of multimedia playback to determine the quality of playback via a network according to the invention, for example by analyzing audio or video bitrate (to determine the quality of a particular media stream), processing latency (to analyze the timing offset produced by any processing or transcoding performed on a media stream, for example by a processor to convert a media stream into a format compatible with a particular destination device), signal-to-noise ratio (to monitor unwanted noise or other artifacts that may affect a viewer’s experience), or timing information between multiple devices, to ensure optimum synchronicity between devices during playback. According to the embodiment, various media playback events may optionally comprise additional information pertaining to quality analysis, such as timing or other information gathered from the device or multimedia file(s) pertaining to the event. In this manner, event-based playback may be enhanced by including various performance metrics for monitoring, and by continuously monitoring those metrics and other readily-available information to ensure an optimum multimedia viewing experience.

[122] According to the invention, a QAM **1503** may be operated by any device in a multimedia playback arrangement according to the invention, and may receive events

and other information via network 1501. In this manner, performance of multiple devices as well as the network being used for playback may be monitored from any device on the network, without special consideration for its function in the arrangement. Additionally, a QAM 1503 may present quality information for viewing or interaction, for example (in an arrangement with a QAM 1503 operating on a mobile device 1504) by using a web interface or a software application that may make quality information accessible to users. For example, various metrics may be presented in an easily understood format, along with options for taking action based on the values observed (such as, for example, applying an offset to an audio or video stream to account for latency). In this manner, quality analysis may be interactive as desired, giving users a fine granularity of control over their playback experience without necessarily requiring any more complexity from a user (they may simply continue playing media without utilizing any of the features of a QAM 1503 if desired), thereby providing a level of interaction and control suitable for different users of different levels of technical ability or interest.

[123] Fig. 14 is a block diagram showing an exemplary system architecture 1600 utilizing multiple quality analysis modules 1603, 1612, 1622, according to an embodiment of the invention. According to the embodiment, a QAM 1603 may be in communication with a multimedia source 1602 or destination device 1610, 1620 over a data communication network 1601 such as the Internet or other suitable network, to receive and process information from such devices for quality analysis purposes. As illustrated, each destination device 1610, 1620 may comprise a playback device 1611, 1621 that may be any suitable device for media playback or consumption, such as for example a portable audio player, smartphone, personal computing device, television, network-capable “smart” speaker, or any other such device as is common in the art. Each destination device may further operate a synchronization module 1613, 1623, that may perform media synchronization tasks as described previously (referring to Fig. 6). As illustrated, a QAM 1612, 1622 may be operated by a destination device, and may be in communication with a synchronization module 1613, 1623 for example to analyze and report on media synchronization operations. In this manner it may be appreciated that by utilizing multiple QAM components 1603, 1612, 1622 in an arrangement,

additional features of a synchronized multimedia playback system may be monitored or analyzed for quality, for example including the quality of media itself in addition to technical quality of a network arrangement or specific devices utilized in the arrangement.

[124] Fig. 15 is a method flow diagram illustrating an exemplary method for quality analysis using event-based media playback across a plurality of devices. In an initial step 1701, a multimedia device (that may be either a media source 1502, 1602 or a destination or playback device 1610, 1620, as described previously in Figs. 13-14) may connect to a network for communication with other connected devices. In a next step 1702, the device may receive event-based data (as described previously in Fig. 6). In a next branched step 1703, a synchronization module 1613, 1623 operated by the device may process the event data for use, and in an alternate branched step 1704 a QAM 1612, 1622 operated by the device may similarly process the event data for its own use. In a next branched step 1705, a synchronization module 1613, 1623 may perform synchronization operations such as by adjusting media playback timing based at least in part on the analyzed event data (as described previously in Fig. 6), and in an alternate branched step 1706 a QAM 1612, 1622 may analyze any quality data contained in the event data (if available). It should be appreciated that one or both branched steps may occur simultaneously or interchangeably, according to the particular nature of the device (for example, some devices may operate a QAM 1612, 1622 but not a synchronization module 1613, 1623). In a final step 1707, the device may send new event data over the network for use by other devices in event-based synchronized playback, and the new event data may comprise new data based at least in part on the results of operation of a synchronization module or QAM 1612, 1622 in previous steps. In an optional additional step 1708, a QAM 1612, 1622 may produce a quality report that may present quality data in a viewable or storable fashion, for example for presentation to a device user via a software application or web interface for viewing and interaction, or for presentation to a database for storage and future reference.

[125] According to a particular arrangement, event data comprising data based at least in part on the results of a synchronization module 1613, 1623 or a QAM 1612, 1622 may be used by devices, upon receipt, in order to direct their own operation to provide

synchronized playback and to optimize network performance. For example, in an arrangement utilizing multiple mobile devices connected via a wireless network 1601, quality and synchronization data may be used to direct a wireless network interface controller (NIC) 1210 (as described previously, referring to Fig. 12) to improve network connectivity or playback synchronization, for example by selecting a particular WiFi channel or cellular frequency band to avoid congestion or interference from other devices. Devices may also direct the operation of media playback to provide synchronized rendering and to accommodate any network delays or other issues, for example by altering the operation of a software media transcoder to change aspects of media being rendered, such as (for example, including but not limited to) selecting different video or audio encoding, altering the resolution of a video stream, altering the bitrate of an audio stream, or changing the allocation of system resources such as processor time or memory usage for use by the transcoder. In this manner, data measurements from a QAM 1612, 1622 and synchronization information from a synchronization module 1613, 1623 may be used to continually optimize playback and network performance for multiple devices according to their particular capabilities and operation, by providing information that may then be used by each particular device to direct its own operation in an ideal manner.

[126] In various embodiments, functionality for implementing systems or methods of the present invention may be distributed among any number of client and/or server components. For example, various software modules may be implemented for performing various functions in connection with the present invention, and such modules can be variously implemented to run on server and/or client components.

[127] The various embodiments disclosed herein accordingly enable the sending of media from a source to multiple media devices, such as TV and speakers in the same listening and viewing space. According to the embodiments, this may be done over a wireless network such as Wi-Fi. The various embodiments enable all of the media rendering devices, such as speakers, that are in the same listening or viewing zone, to be precisely synchronized to each other, so the listener and/or viewer does not discern any unintended media experience.

[128] The skilled person will be aware of a range of possible modifications of the various embodiments described above. Accordingly, the present invention is defined by the claims and their equivalents.

What is claimed is:

1. A system for synchronous media rendering over wireless networks with wireless performance monitoring, comprising:
 - a plurality of network-connected media devices comprising at least a source device and a plurality of destination devices, the source device comprising a plurality of programming instructions stored in a memory of and operating on a processor of a computing device, the programming code configured to stream media over a network, and the destination devices each comprising at least a local clock and connected via the network to the source device and configured to render media received over the network;
 - a quality analysis module operating on at least one of the plurality of media devices and configured to monitor at least a portion of the media being streamed over the network, and configured to direct the operation of a synchronization module based at least in part on the analysis results; and
 - a synchronization module operating on at least one of the plurality of devices and configured to direct rendering of media data based on received event data, and configured to transmit event data to at least a portion of the plurality of destination devices;
2. The system of claim 1, wherein the analysis comprises at least selecting a received metric value and comparing at least the value to a plurality of previously-known values to determine the quality of a rendering.
3. The system of claim 1, wherein the synchronization module produces and transmits event data based at least in part on the analysis results.
4. A method for synchronous media rendering over wireless networks with wireless performance monitoring, comprising the steps of:
 - deploying a plurality of network-connected media devices comprising at least a source device and a plurality of destination devices, the source device comprising a plurality of programming instructions stored in a memory of and operating on a processor of a computing device, the programming code configured to stream media over a network, and the plurality of destination devices each comprising at least a local

clock and connected via the network to the source device, the plurality of destination devices configured to render media received over the network;

receiving, at a first destination device, media data comprising at least event data and media for rendering from the source device;

rendering, using a synchronization module operating on the first destination device configured to direct the rendering of media data based on received event data, the first destination device configured to transmit event data to at least a portion of the plurality of destination devices, the media data based at least in part on the event data;

monitoring, using a quality analysis module operating on at least one of the plurality of media devices and configured to monitor at least a portion of the media being streamed over the network, the at least one of the plurality of media devices configured to direct the operation of the synchronization module based at least in part on the analysis results, at least a portion of the media as it is rendered;

analyzing at least the monitored portion of the media rendering; and

transmitting event data based at least in part on the analysis results.

5. The method of claim 4, further comprising the step of producing a quality report based at least in part on the analysis results.

6. The method of claim 5, wherein the quality report is stored for future reference.

7. The method of claim 5, wherein the quality report is presented to a display user for review.

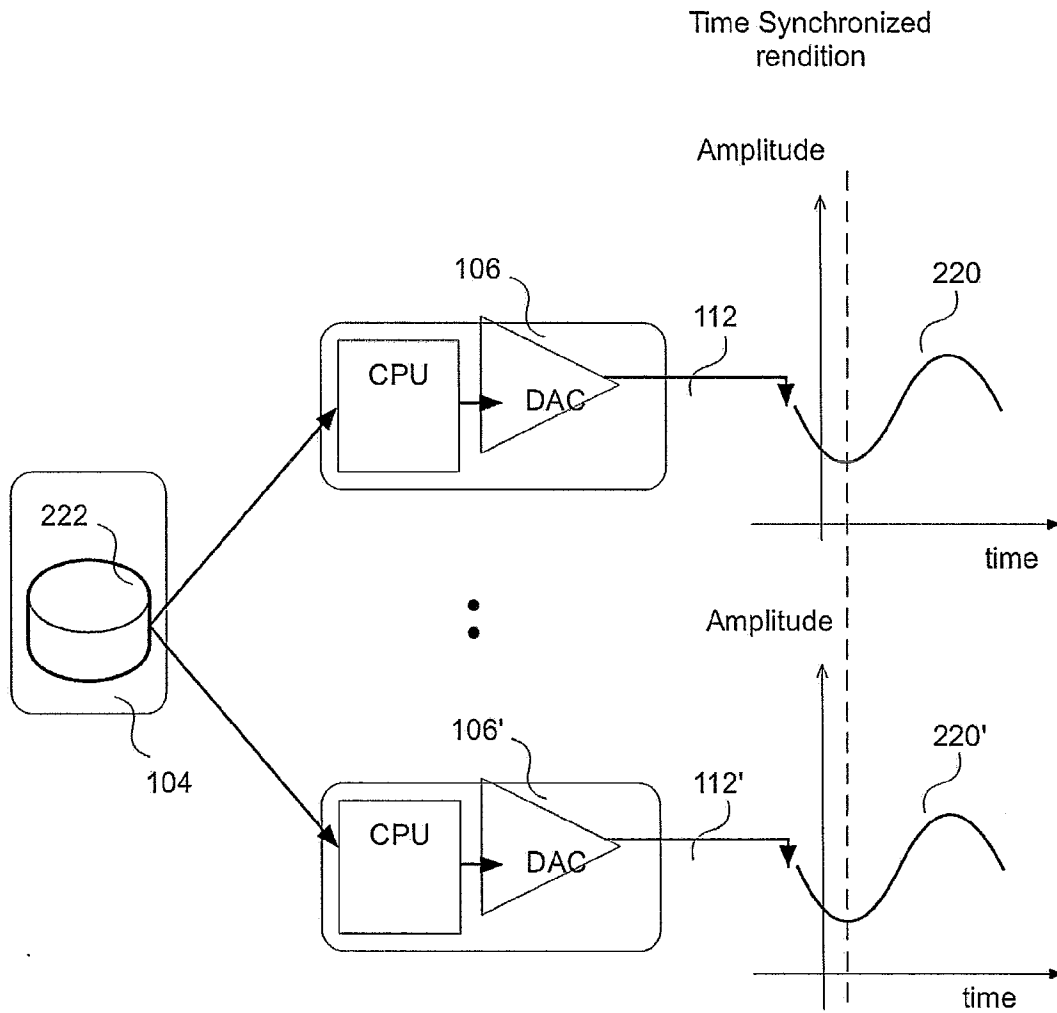

Fig. 1

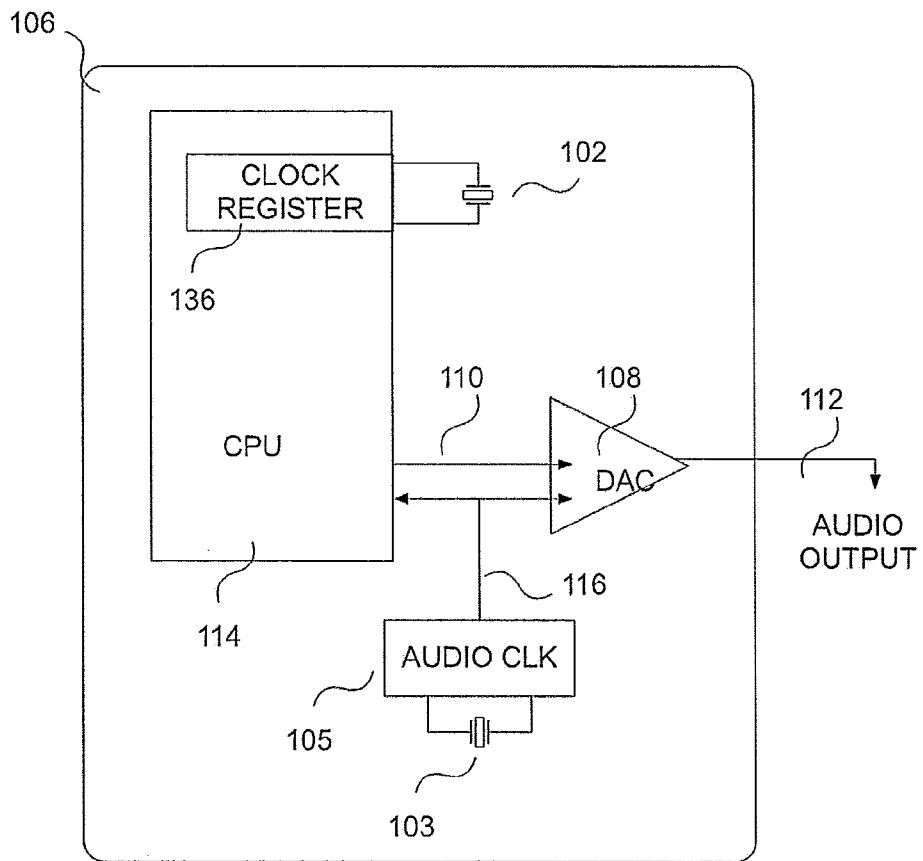

Fig. 2

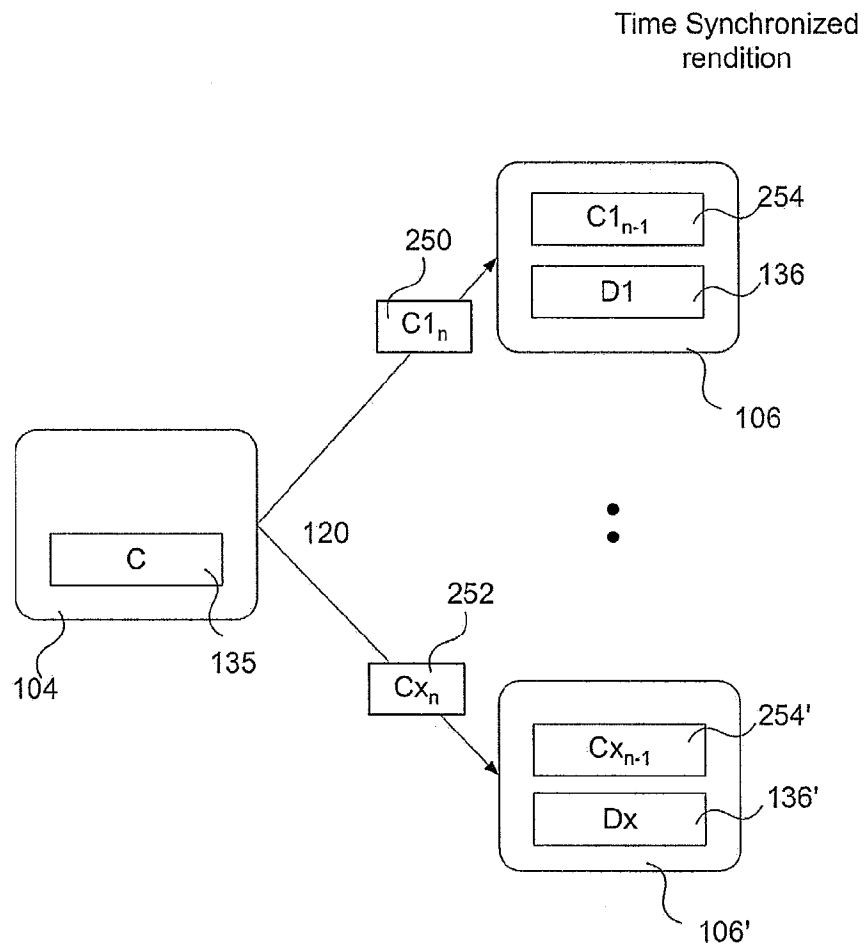

Fig. 3

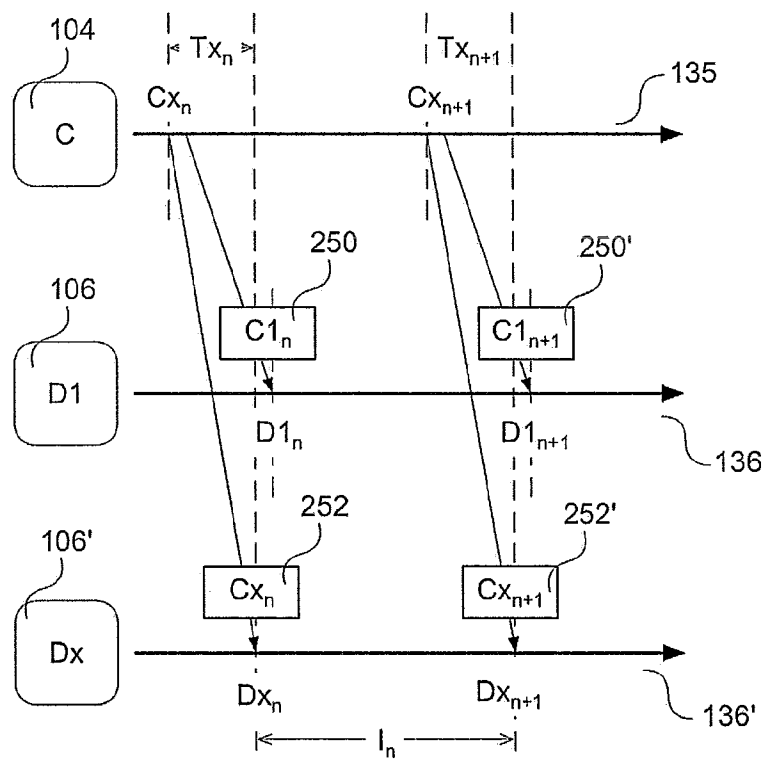

Fig. 4

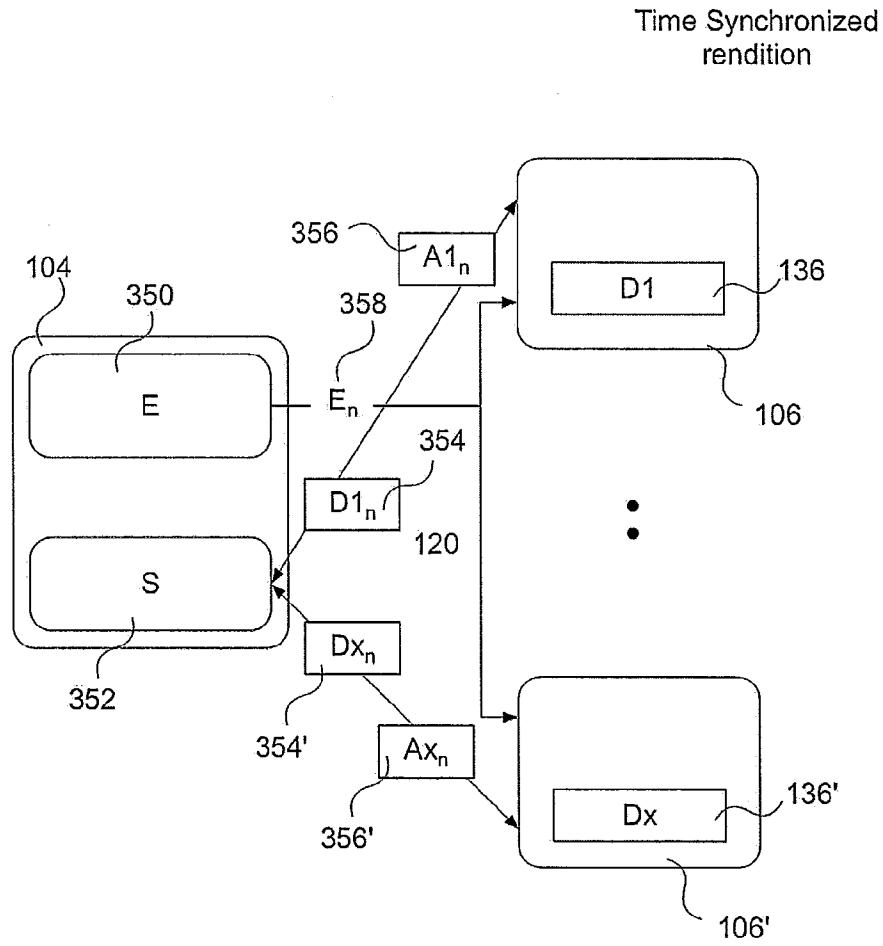

Fig. 5

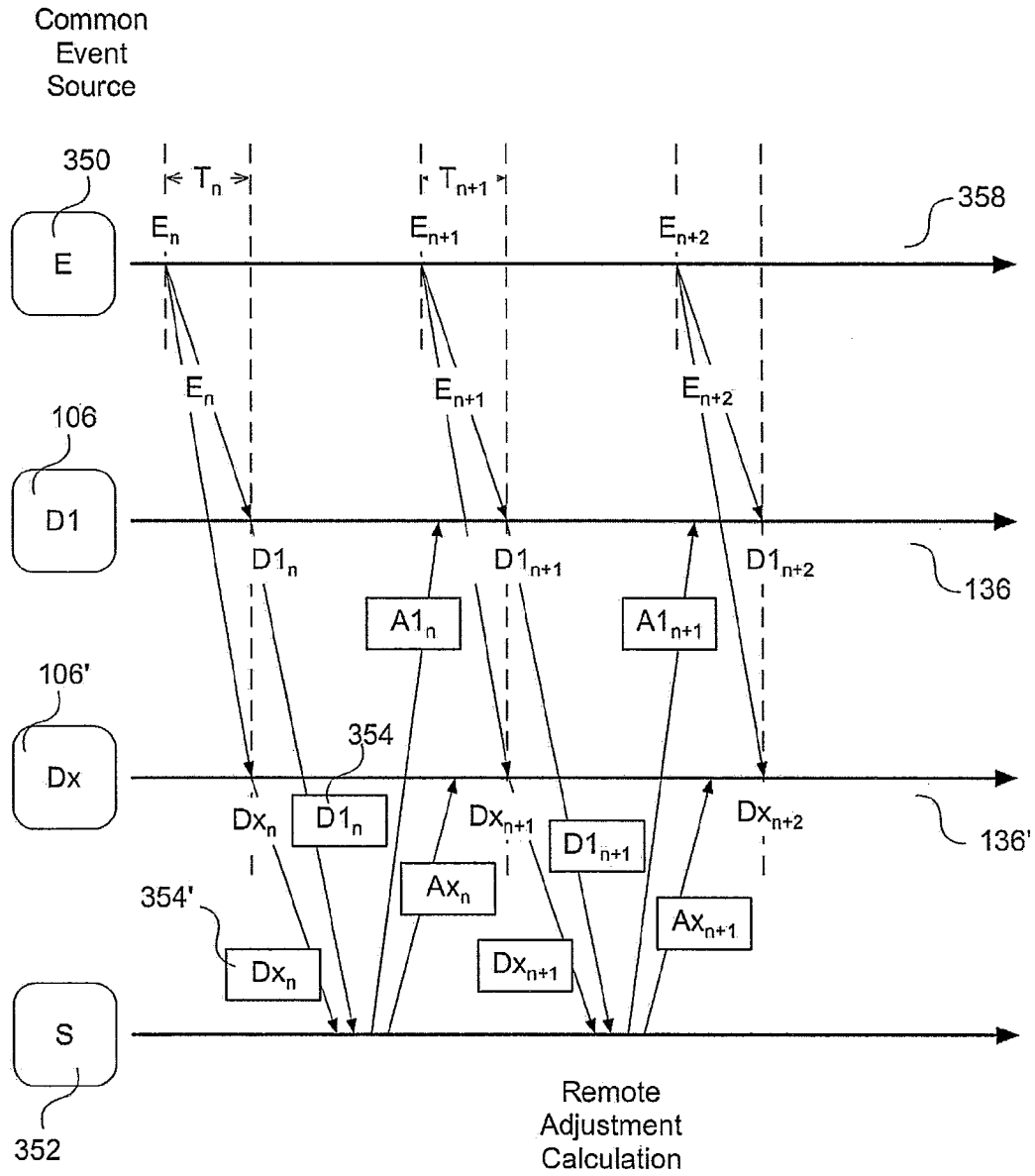

Fig. 6

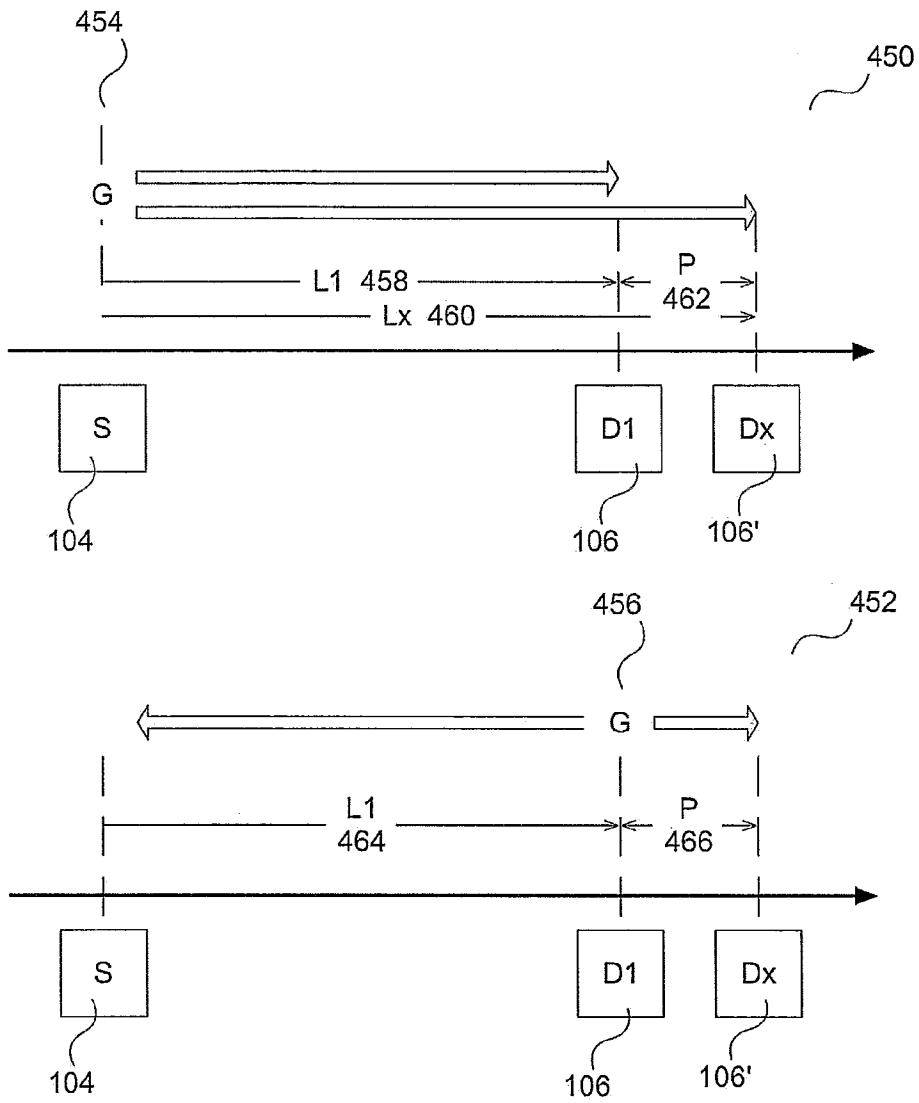

Fig. 7

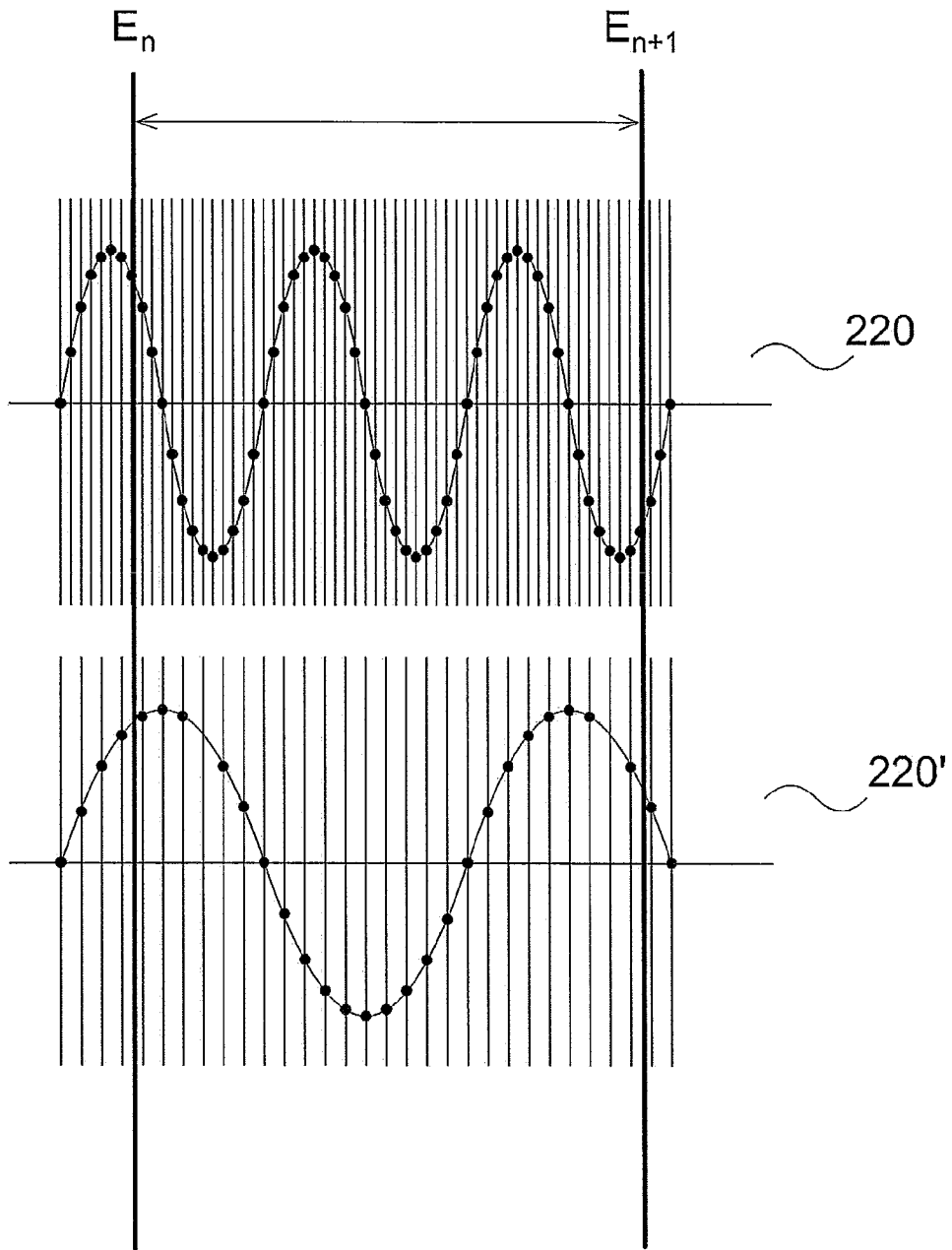

Fig. 8

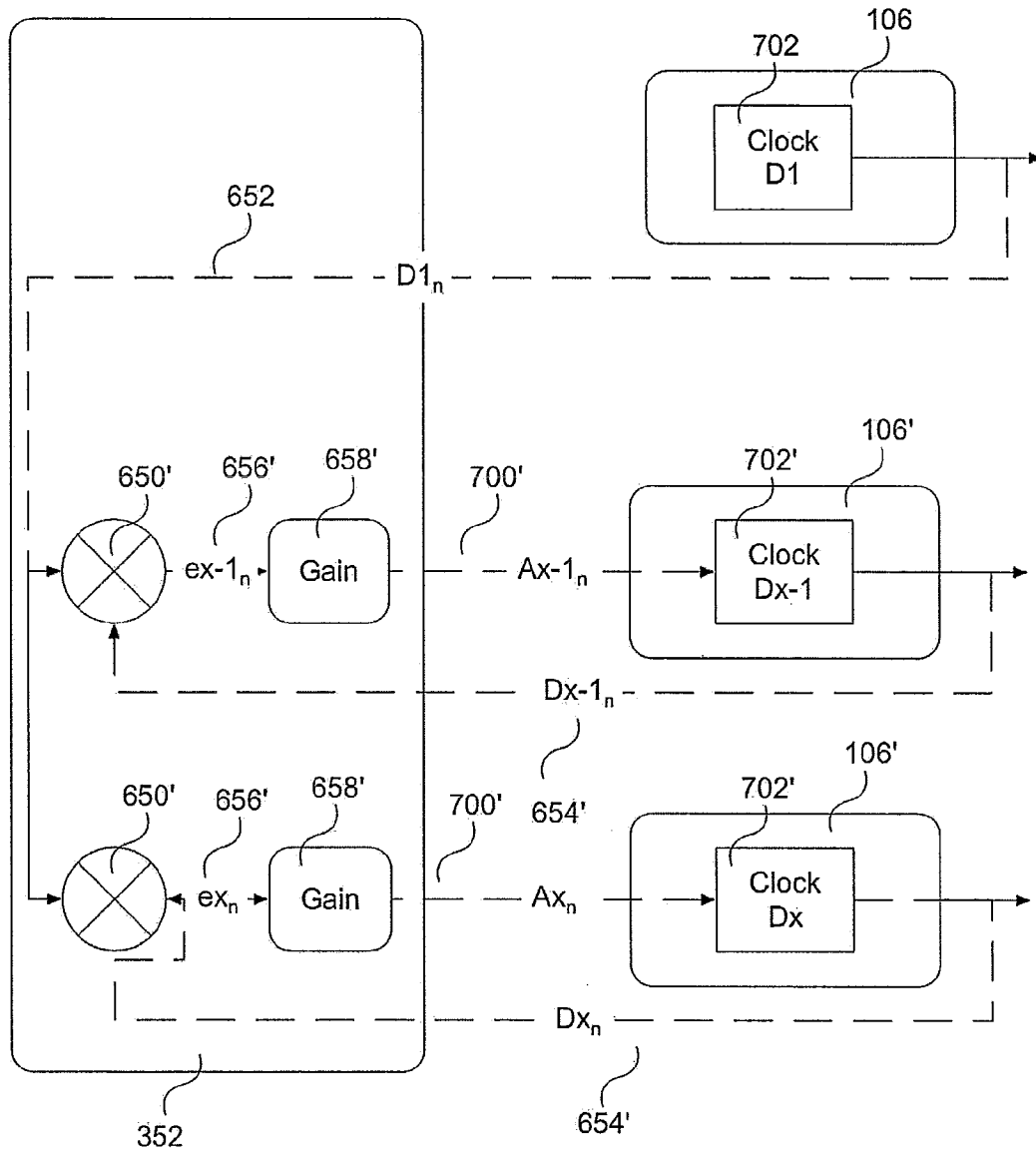

Fig. 9

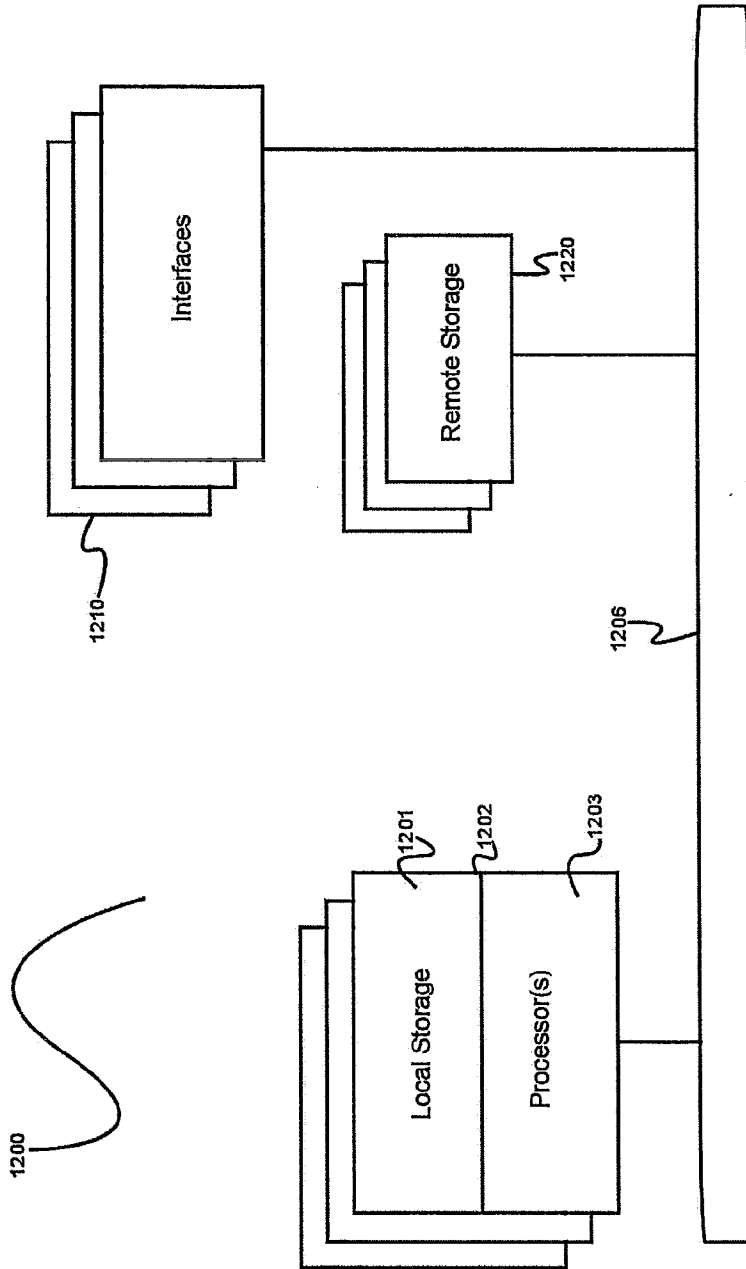

Fig. 10

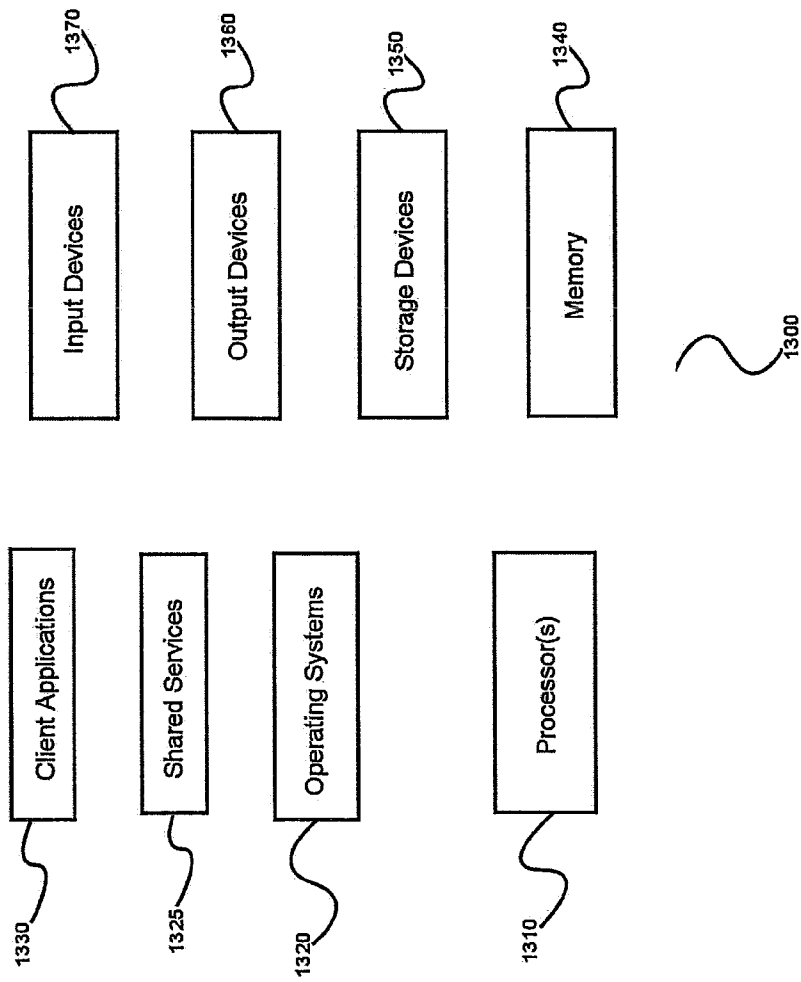

Fig. 11

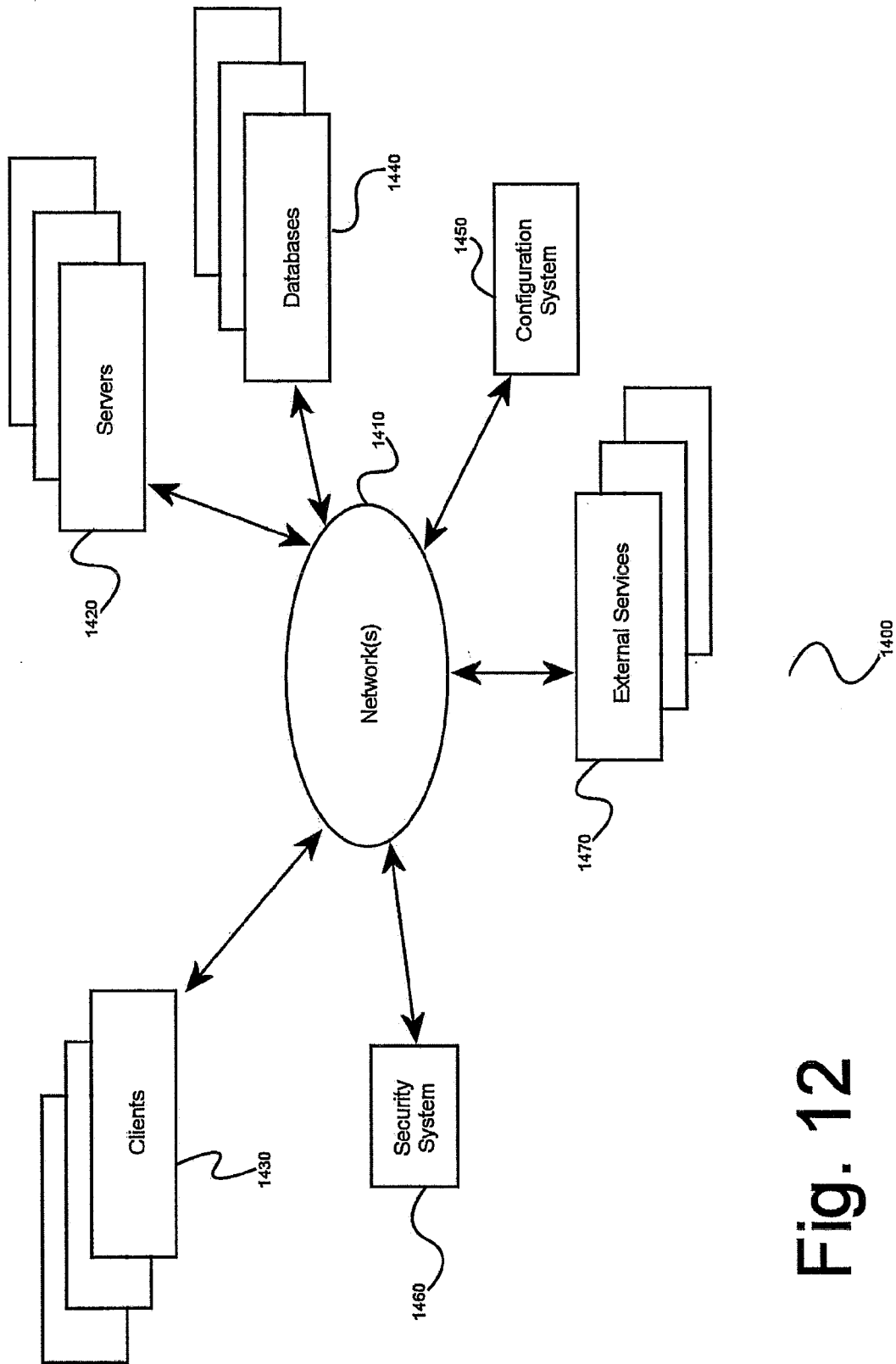

Fig. 12

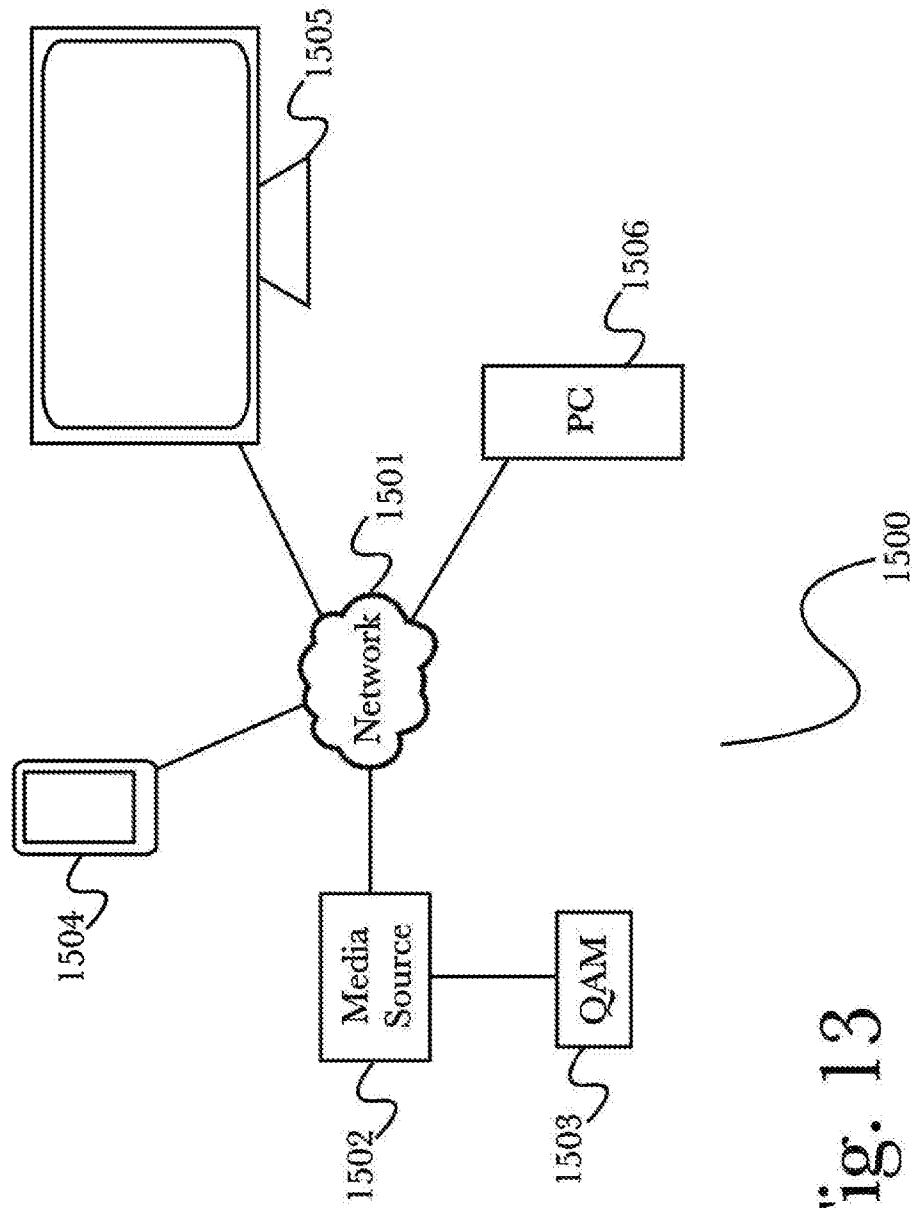

Fig. 13

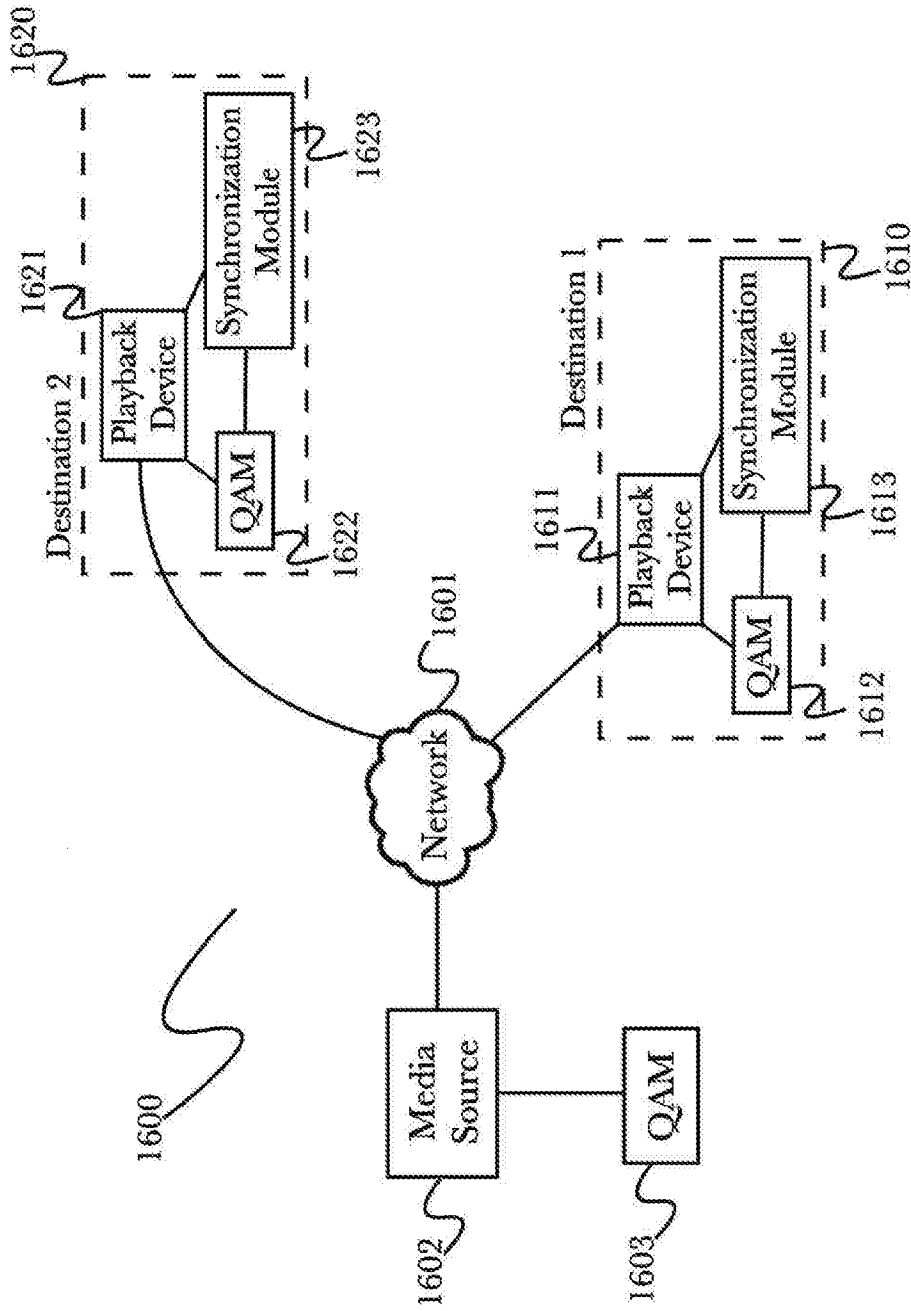

Fig. 14

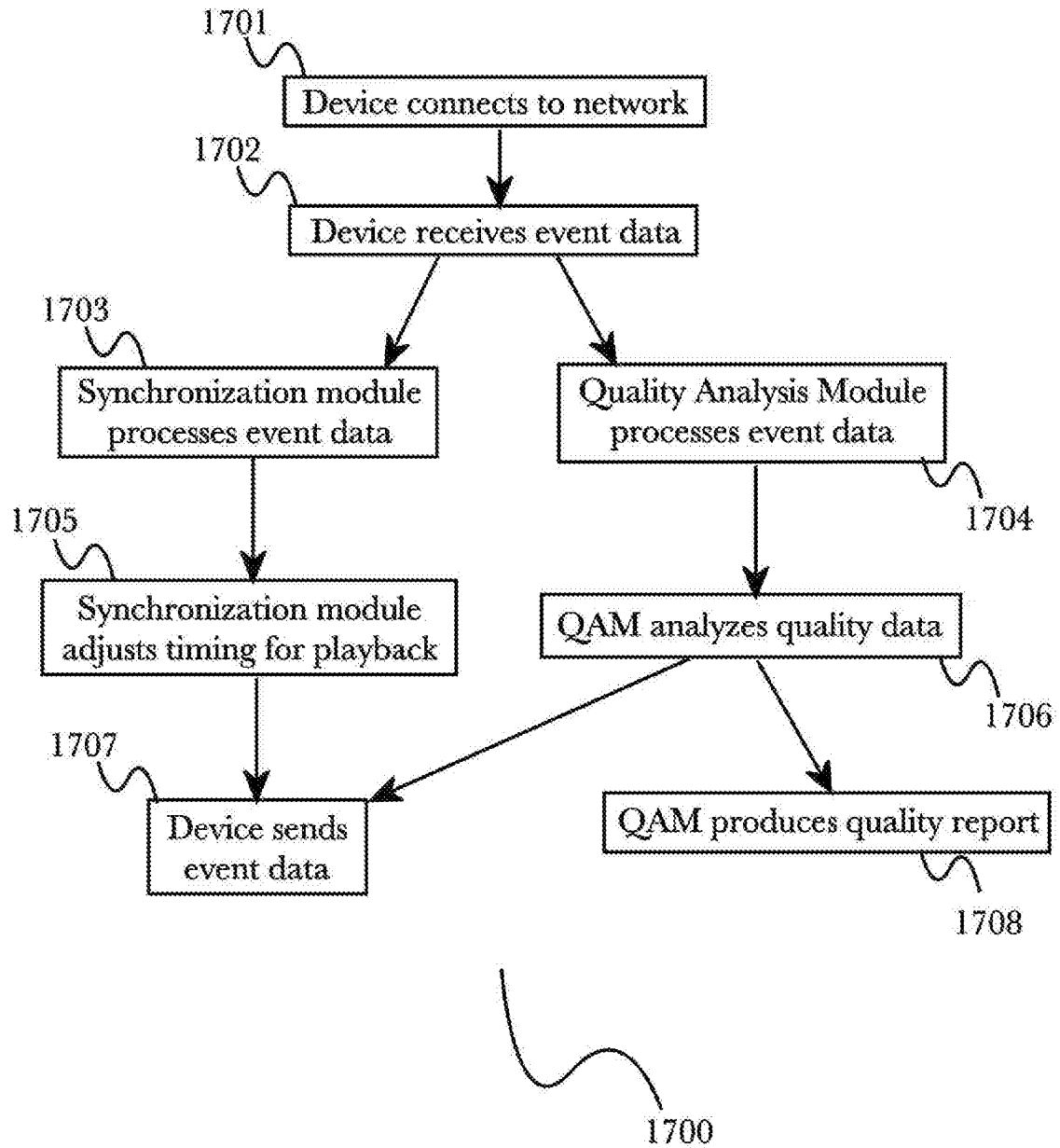

Fig. 15

INTERNATIONAL SEARCH REPORT

International application No.

PCT/US 2016/018543

A. CLASSIFICATION OF SUBJECT MATTER		
H04N 21/242 (2011.01)		
According to International Patent Classification (IPC) or to both national classification and IPC		
B. FIELDS SEARCHED		
Minimum documentation searched (classification system followed by classification symbols)		
H04N 21/00-21/242, 5/00-5/935, G06F 15/00-15/16		
Documentation searched other than minimum documentation to the extent that such documents are included in the fields searched		
Electronic data base consulted during the international search (name of data base and, where practicable, search terms used)		
PatSearch (RUPTO internal), USPTO, PAJ, K-PION, Esp@cenet, Information Retrieval System of FIPS		
C. DOCUMENTS CONSIDERED TO BE RELEVANT		
Category*	Citation of document, with indication, where appropriate, of the relevant passages	Relevant to claim No.
X	US 2013/0336626 A1 (PRIMAX ELECTRONICS LTD) 19.12.2013, abstract, paragraphs [0026]-[0028], [0030]-[0032], [0035]-[0038], [0040]-[0042]	1-7
A	US 2013/0031217 A1 (RAJAPAKSE RAVI U) 31.01.2013	1-7
<input type="checkbox"/> Further documents are listed in the continuation of Box C. <input type="checkbox"/> See patent family annex.		
* Special categories of cited documents: "A" document defining the general state of the art which is not considered to be of particular relevance "E" earlier document but published on or after the international filing date "L" document which may throw doubts on priority claim(s) or which is cited to establish the publication date of another citation or other special reason (as specified) "O" document referring to an oral disclosure, use, exhibition or other means "P" document published prior to the international filing date but later than the priority date claimed	"T" later document published after the international filing date or priority date and not in conflict with the application but cited to understand the principle or theory underlying the invention "X" document of particular relevance; the claimed invention cannot be considered novel or cannot be considered to involve an inventive step when the document is taken alone "Y" document of particular relevance; the claimed invention cannot be considered to involve an inventive step when the document is combined with one or more other such documents, such combination being obvious to a person skilled in the art "&" document member of the same patent family	
Date of the actual completion of the international search		Date of mailing of the international search report
14 June 2016 (14.06.2016)		23 June 2016 (23.06.2016)
Name and mailing address of the ISA/RU: Federal Institute of Industrial Property, Berezhkovskaya nab., 30-1, Moscow, G-59, GSP-3, Russia, 125993 Facsimile No: (8-495) 531-63-18, (8-499) 243-33-37		Authorized officer A. Tokarev Telephone No. (499) 240-25-91