

(19)



(11)

EP 1 837 950 A2

(12)

EUROPEAN PATENT APPLICATION

(43) Date of publication:
26.09.2007 Bulletin 2007/39

(51) Int Cl.:
H01Q 1/36 (2006.01) *H01Q 1/38* (2006.01)
H01Q 1/48 (2006.01) *H01Q 5/00* (2006.01)
H01Q 9/04 (2006.01)

(21) Application number: **07107431.4**

(22) Date of filing: **13.09.2001**

(84) Designated Contracting States:
**AT BE CH CY DE DK ES FI FR GB GR IE IT LI LU
MC NL PT SE TR**

- **Puente Baliarda, Carles**
08190 Santa Cugat del Valles (Barcelona) (ES)

(62) Document number(s) of the earlier application(s) in accordance with Art. 76 EPC:
01983481.1 / 1 425 820

(74) Representative: **Carpintero Lopez, Francisco et al**
Herrero & Asociados, S.L.
Alcalá 35
28014 Madrid (ES)

(71) Applicant: **Fractus, S.A.**
08190 San Cugat Del Valles (Barcelona) (ES)

Remarks:
This application was filed on 03 - 05 - 2007 as a divisional application to the application mentioned under INID code 62.

(72) Inventors:

- **Quintero Illera, Ramiro**
08921 Santa Coloma de Gramenet (Barcelona) (ES)

(54) **Multilevel and space-filling round-planes for miniature and multiband antennas**

(57) An antenna system includes one or more conductive elements acting as radiating elements, and a multilevel or space-filling ground-plane, wherein said ground-plane has a particular geometry which affects the operating characteristics of the antenna. The return loss,

bandwidth, gain, radiation efficiency, and frequency performance can be controlled through multilevel and space-filling ground-plane design. Also, said ground-plane can be reduced compared to those of antennas with solid ground-planes.

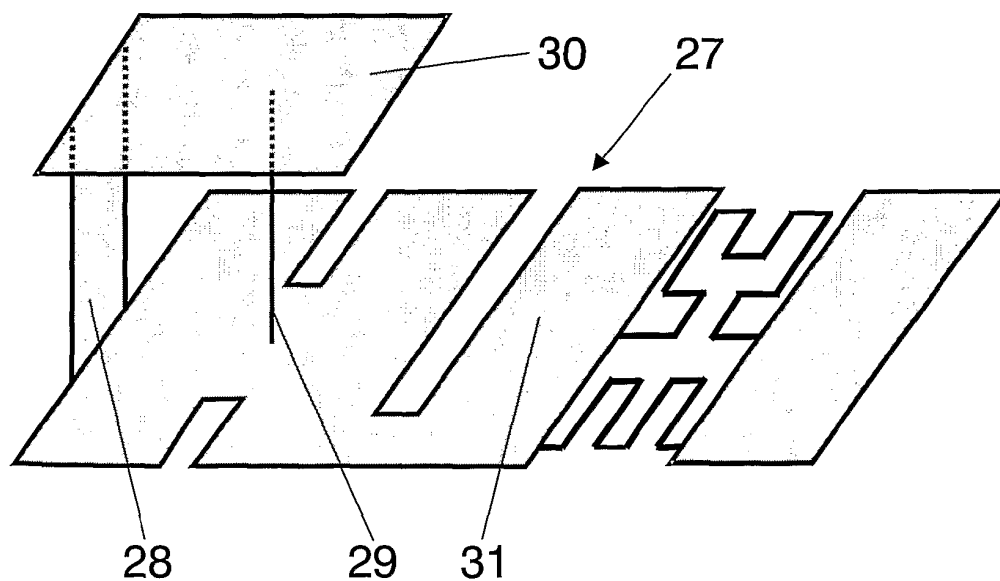

FIG.3B

EP 1 837 950 A2

Description

OBJECT AND BACKGROUND OF THE INVENTION

[0001] The present invention relates generally to a new family of antenna ground-planes of reduced size and enhanced performance based on an innovative set of geometries. These new geometries are known as multilevel and space-filling structures, which had been previously used in the design of multiband and miniature antennas. A throughout description of such multilevel or space-filling structures can be found in "*Multilevel Antennas*" (Patent Publication No. WO01/22528) and "*Space-Filling Miniature Antennas*" (Patent Publication No. WO01/54225).

[0002] The current invention relates to the use of such geometries in the ground-plane of miniature and multiband antennas. In many applications, such as for instance mobile terminals and handheld devices, it is well known that the size of the device restricts the size of the antenna and its ground-plane, which has a major effect on the overall antenna performance. In general terms, the bandwidth and efficiency of the antenna are affected by the overall size, geometry, and dimensions of the antenna and the ground-plane. A report on the influence of the ground-plane size in the bandwidth of terminal antennas can be found in the publication "Investigation on Integrated Antennas for GSM Mobile Phones", by D. Manteuffel, A. Bahr, I. Wolff, Millennium Conference on Antennas & Propagation, ESA, AP2000, Davos, Switzerland, April 2000. In the prior art, most of the effort in the design of antennas including ground-planes (for instance microstrip, planar inverted-F or monopole antennas) has been oriented to the design of the radiating element (that is, the microstrip patch, the PIFA element, or the monopole arm for the examples described above), yet providing a ground-plane with a size and geometry that were mainly dictated by the size or aesthetics criteria according to every particular application.

[0003] One of the key issues of the present invention is considering the ground-plane of an antenna as an integral part of the antenna that mainly contributes to its radiation and impedance performance (impedance level, resonant frequency, bandwidth). A new set of geometries are disclosed here, such a set allowing to adapt the geometry and size of the ground-plane to the ones required by any application (base station antennas, handheld terminals, cars, and other motor-vehicles and so on), yet improving the performance in terms of, for instance, bandwidth, Voltage Standing Wave Ratio (hereafter VSWR), or multiband behaviour.

[0004] The use of multilevel and space-filling structures to enhance the frequency range an antenna can work within was well described in patent publication numbers WO01/22528 and WO01/54225. Such an increased range is obtained either through an enhancement of the antenna bandwidth, with an increase in the number of frequency bands, or with a combination of both effects.

In the present invention, said multilevel and space-filling structures are advantageously used in the ground-plane of the antenna obtaining this way either a better return loss or VSWR, a better bandwidth, a multiband behaviour, or a combination of all these effects. The technique can be seen as well as a means of reducing the size of the ground-plane and therefore the size of the overall antenna.

[0005] A first attempt to improve the bandwidth of microstrip antennas using the ground-plane was described by T. Chiou, K. Wong, "Designs of Compact Microstrip Antennas with a Slotted Ground Plane". IEEE-APS Symposium, Boston, 8-12 July, 2001. The skilled in the art will notice that even though the authors claim the improved performance is obtained by means of some slots on the antenna ground-plane, those were unintentionally using a very simple case of multilevel structure to modify the resonating properties of said ground-plane. In particular, a set of two rectangles connected through three contact points and a set of four rectangles connected through five contact points were described there. Another example of an unintentional use of a multilevel ground structure in an antenna ground-plane is described in U.S. Pat. No. 5,703,600. There, a particular case of a ground-plane composed by three rectangles with a capacitive electromagnetic coupling between them was used. It should be stressed that neither in the paper by Chiou and Wong, nor in patent US5,703,600, the general configuration for space-filling or multilevel structures were disclosed or claimed, so the authors were not attempting to use the benefits of said multilevel or space-filling structures to improve the antenna behaviour.

[0006] Some of the geometries described in the present invention are inspired in the geometries already studied in the 19th century by several mathematicians such as Giuseppe Peano and David Hilbert. In all said cases the curves were studied from the mathematical point of view but were never used for any practical engineering application. Such mathematical abstractions can be approached in a practical design by means of the general space-filling curves described in the present invention. Other geometries, such as the so called SZ, ZZ, HilbertZZ, Peanoinc, Peanodec or PeanoZZ curves described in patent publication WO01/54225 are included in the set of space-filling curves used in an innovative way in the present invention. It is interesting to notice that in some cases, such space-filling curves can be used to approach ideal fractal shapes as well.

[0007] The dimension (D) is often used to characterize highly complex geometrical curves and structures such as those described in the present invention. There exists many different mathematical definitions of dimension but in the present document the box-counting dimension (which is well-known to those skilled in mathematics theory) is used to characterize a family of designs. Again, the advantage of using such curves in the novel configuration disclosed in the present invention is mainly the overall antenna miniaturization together with and en-

hancement of its bandwidth, impedance, or multiband behaviour.

[0008] Although usually not as efficient as the general space-filling curves disclosed in the present invention, other well-known geometries such as meandering and zigzag curves can also be used in a novel configuration according to the spirit and scope of the present invention. Some descriptions of using zigzag or meandering curves in antennas can be found for instance in patent publication WO96/27219, but it should be noticed that in the prior-art such geometries were used mainly in the design of the radiating element rather than in the design of the ground-plane as it is the purpose and basis of several embodiments in the present invention.

SUMMARY OF THE INVENTION

[0009] The key point of the present invention is shaping the ground-plane of an antenna in such a way that the combined effect of the ground-plane and the radiating element enhances the performance and characteristics of the whole antenna device, either in terms of bandwidth, VSWR, multiband behaviour, efficiency, size, or gain. Instead of using the conventional solid geometry for ground-planes as commonly described in the prior art, the invention disclosed here introduces a new set of geometries that forces the currents on the ground-plane to flow and radiate in a way that enhances the whole antenna behaviour.

[0010] The basis of the invention consists of breaking the solid surface of a conventional ground-plane into a number of conducting surfaces (at least two of them) said surfaces being electromagnetically coupled either by the capacitive effect between the edges of the several conducting surfaces, or by a direct contact provided by a conducting strip, or a combination of both effects.

[0011] The resulting geometry is no longer a solid, conventional ground-plane, but a ground-plane with a multilevel or space-filling geometry, at least in a portion of said ground-plane.

[0012] A Multilevel geometry for a ground-plane consists of a conducting structure including a set of polygons, all of said polygons featuring the same number of sides, wherein said polygons are electromagnetically coupled either by means of a capacitive coupling or ohmic contact, wherein the contact region between directly connected polygons is narrower than 50% of the perimeter of said polygons in at least 75% of said polygons defining said conducting ground-plane. In this definition of multilevel geometry, circles and ellipses are included as well, since they can be understood as polygons with infinite number of sides.

[0013] On the other hand, an Space-Filling Curve (hereafter SFC) is a curve that is large in terms of physical length but small in terms of the area in which the curve can be included. More precisely, the following definition is taken in this document for a space-filling curve: a curve composed by at least ten segments which are connected

in such a way that each segment forms an angle with their neighbours, that is, no pair of adjacent segments define a larger straight segment, and wherein the curve can be optionally periodic along a fixed straight direction of space if, and only if, the period is defined by a non-periodic curve composed by at least ten connected segments and no pair of said adjacent and connected segments defines a straight longer segment. Also, whatever the design of such SFC is, it can never intersect with itself at any point except the initial and final point (that is, the whole curve can be arranged as a closed curve or loop, but none of the parts of the curve can become a closed loop). A space-filling curve can be fitted over a flat or curved surface, and due to the angles between segments, the physical length of the curve is always larger than that of any straight line that can be fitted in the same area (surface) as said space-filling curve. Additionally, to properly shape the ground-plane according to the present invention, the segments of the SFC curves included in said ground-plane must be shorter than a tenth of the free-space operating wavelength.

[0014] Depending on the shaping procedure and curve geometry, some infinite length SFC can be theoretically designed to feature a Hausdorff dimension larger than their topological-dimension. That is, in terms of the classical Euclidean geometry, it is usually understood that a curve is always a one-dimension object; however when the curve is highly convoluted and its physical length is very large, the curve tends to fill parts of the surface which supports it; in that case, the Hausdorff dimension can be computed over the curve (or at least an approximation of it by means of the box-counting algorithm) resulting in a number larger than unity. The curves described in Figure 2 are some examples of such SFC; in particular, drawings 11, 13, 14, and 18 show some examples of SFC curves that approach an ideal infinite curve featuring a dimension $D = 2$. As known by those skilled in the art, the box-counting dimension can be computed as the slope of the straight portion of a log-log graph, wherein such a straight portion is substantially defined as a straight segment. For the particular case of the present invention, said straight segment will cover at least an octave of scales on the horizontal axis of the log-log graph.

[0015] Depending on the application, there are several ways for establishing the required multilevel and space-filling metallic pattern according to the present invention. Due to the special geometry of said multilevel and space-filling structures, the current distributes over the ground-plane in such a way that it enhances the antenna performance and features in terms of:

- (a) Reduced size compared to antennas with a solid ground-plane.
- (b) Enhanced bandwidth compared to antennas with a solid ground-plane.
- (c) Multifrequency performance.
- (d) Better VSWR feature at the operating band or

bands.

(e) Better radiation efficiency.

(f) Enhanced gain.

[0016] It will be clear that any of the general and newly described ground-planes of the present invention can be advantageously used in any of the prior-art antenna configurations that require a ground-plane, for instance: antennas for handheld terminals (cellular or cordless telephones, PDAs, electronic pagers, electronic games, or remote controls), base station antennas (for instance for coverage in micro-cells or pico-cells for systems such as AMPS, GSM900, GSM1800, UMTS, PCS1900, DCS, DECT, WLAN, ...), car antennas, and so on. Such antennas can usually take the form of microstrip patch antennas, slot-antennas, Planar Inverted-F (PIFA) antennas, monopoles and so on, and in all those cases where the antenna requires a ground-plane, the present invention can be used in an advantageous way. Therefore, the invention is not limited to the aforementioned antennas. The antenna could be of any other type as long as a ground-plane is included.

BRIEF DESCRIPTION OF THE DRAWINGS

[0017] For a better understanding of the present invention, reference will now be made to the appended drawings in which:

Figure 1 shows a comparison between two prior art ground-planes and a new multilevel ground-plane. Drawing 1 shows a conventional ground-plane formed by only one solid surface (rectangle, prior-art), whereas drawing 2 shows a particular case of ground-plane that has been broken in two surfaces 5 and 6 (rectangles) connected by a conducting strip 7, according to the general techniques disclosed in the present invention. Drawing 3 shows a ground-plane where the two conducting surfaces 5 and 6, separated by a gap 4, are being connected through capacitive effect (prior-art).

Figure 2 shows some examples of SFC curves. From an initial curve 8, other curves 9, 10, and 11 are formed (called Hilbert curves). Likewise, other set of SFC curves can be formed, such as set 12, 13, and 14 (called SZ curves); set 15 and 16 (known as ZZ curves); set 17, 18, and 19 (called HilbertZZ curves); set 20 (Peanodec curve); and set 21 (based on the Giuseppe Peano curve).

Figure 3A shows a perspective view of a conventional (prior-art) Planar Inverted-F Antenna or PIFA (22) formed by a radiating antenna element 25, a conventional solid surface ground-plane 26, a feed point 24 coupled somewhere on the patch 25 depending upon the desired input impedance, and a short-circuit 23 coupling the patch element 25 to the ground-

plane 26. Figure 3B shows a new configuration (27) for a PIFA antenna, formed by an antenna element 30, a feed point 29, a short-circuit 28, and a particular example of a new ground-plane structure 31 formed by both multilevel and space-filling geometries.

Figure 4A is a representational perspective view of the conventional configuration (prior-art) for a monopole 33 over a solid surface ground-plane 34. Figure 4B shows an improved monopole antenna configuration 35 where the ground-plane 37 is composed by multilevel and space-filling structures.

Figure 5A shows a perspective view of a patch antenna system 38 (prior-art) formed by a rectangular radiating element patch 39 and a conventional ground-plane 40. Figure 5B shows an improved antenna patch system composed by a radiating element 42 and a multilevel and space-filling ground-plane 43.

Figure 6 shows several examples of different contour shapes for multilevel ground-planes, such as rectangular (44, 45, and 46) and circular (47, 48, and 49). In this case, circles and ellipses are taken as polygons with infinite number of sides.

Figure 7 shows a series of same-width multilevel structures (in this case rectangles), where conducting surfaces are being connected by means of conducting strips (one or two) that are either aligned or not aligned along a straight axis.

Figure 8 shows that not only same-width structures can be connected via conducting strips. More than one conducting strips can be used to interconnect rectangular polygons as in drawings 59 and 61. Also it is disclosed some examples of how different width and length conducting strips among surfaces can be used within the spirit of the present invention.

Figure 9 shows alternative schemes of multilevel ground-planes. The ones being showed in the figure (68 to 76) are being formed from rectangular structures, but any other shape could have been used.

Figure 10 shows examples (77 and 78) of two conducting surfaces (5 and 6) being connected by one (10) or two (9 and 10) SFC connecting strips.

Figure 11 shows examples wherein at least a portion of the gap between at least two conducting surfaces is shaped as an SPC connecting strip.

Figure 12 shows a series of ground-planes where at least one of the parts of said ground-planes is shaped as SFC. In particular, the gaps (84, 85) between conducting surfaces are shaped in some cases as SFC.

Figure 13 shows another set of examples where parts of the ground-planes such as the gaps between conducting surfaces are being shaped as SFC.

Figure 14 shows more schemes of ground-planes (91 and 92) with different SFC width curves (93 and 94). Depending on the application, configuration 91 can be used to minimize the size of the antenna while configuration 92 is preferred for enhancing bandwidth in a reduced size antenna while reducing the backward radiation.

Figure 15 shows a series of conducting surfaces with different widths being connected through SFC conducting strips either by direct contact (95, 96, 97, 98) or by capacitive effect (central strip in 98).

Figure 16 shows examples of multilevel ground-planes (in this case formed by rectangles).

Figure 17 shows another set examples of multilevel ground-planes.

Figure 18 shows examples of multilevel ground-planes where at least two conducting surfaces are being connected through meandering curves with different lengths or geometries. Some of said meandering lines can be replaced by SFC curves if a further size reduction or a different frequency behaviour is required.

Figure 19 shows examples of antennas wherein the radiating element has substantially the same shape as the ground-plane, thereby obtaining a symmetrical or quasymmetrical configuration, and where said radiating element is placed parallel (drawing 127) or orthogonal (drawing 128) to said ground-plane.

DETAILED DESCRIPTION OF THE PREFERRED EMBODIMENTS

[0018] In order to construct an antenna assembly according to embodiments of our invention, a suitable antenna design is required. Any number of possible configurations exists, and the actual choice of antenna is dependent, for instance, on the operating frequency and bandwidth, among other antenna parameters. Several possible examples of embodiments are listed hereinafter.

[0019] However, in view of the foregoing description it will be evident to a person skilled in the art that various modifications may be made within the scope of the invention. In particular, different materials and fabrication processes for producing the antenna system may be selected, which still achieve the desired effects. Also, it would be clear that other multilevel and space-filling geometries could be used within the spirit of the present invention.

[0020] Figure 3A shows in a manner already known in prior art a Planar Inverted-F (22) Antenna (hereinafter PIFA Antenna) being composed by a radiating antenna element 25, a conventional solid surface ground-plane 26, a feed point 24 coupled somewhere on the patch 25 depending upon the desired input impedance, and a short-circuit 23 coupling the patch element 25 to the ground-plane 26. The feed point 24 can be implemented in several ways, such a coaxial cable, the sheath of which is coupled to the ground-plane and the inner conductor 24 of which is coupled to the radiating conductive element 25. The radiating conductive element 25 is usually shaped like a quadrangle, but several other shapes can be found in other patents or scientific articles. Shape and dimensions of radiating element 25 will contribute in determining operating frequency of the overall antenna system. Although usually not considered as a part of the design, the ground-plane size and geometry also has an effect in determining the operating frequency and bandwidth for said PIFA. PIFA antennas have become a hot topic lately due to having a form that can be integrated into the per se known type of handset cabinets.

[0021] Unlike the prior art PIFA ground-planes illustrated in Fig. 3A, the newly disclosed ground-plane 31 according to Fig. 3B is composed by multilevel and space-filling structures obtaining this way a better return loss or VSWR, a better bandwidth, and multiband behaviour, along with a compressed antenna size (including ground-plane). The particular embodiment of PIFA 27 is composed by a radiating antenna element 30, a multilevel and space-filling ground-plane 31, a feed point 29 coupled somewhere on the patch 30, and a short-circuit 28 coupling the patch element 30 to the ground-plane 31. For the sake of clarity but without loss of generality, a particular case of multilevel ground-plane 31 is showed, where several quadrangular surfaces are being electromagnetically coupled by means of direct contact through conducting strips and said polygons, together with an SFC and a meandering line. More precisely, the multilevel structure is formed with 5 rectangles, said multilevel structure being connected to a rectangular surface by means of SFC (8) and a meandering line with two periods. It is clear to those skilled in the art that those surfaces could have been any other type of polygons with any size, and being connected in any other manner such as any other SFC curve or even by capacitive effect. For the sake of clarity, the resulting surfaces defining said ground-plane are lying on a common flat surface, but other conformal configurations upon curved or bent surfaces could have been used as well.

[0022] For this preferred embodiment, the edges between coupled rectangles are either parallel or orthogonal, but they do not need to be so. Also, to provide the ohmic contact between polygons several conducting strips can be used according to the present invention. The position of said strips connecting the several polygons can be placed at the center of the gaps as in Fig. 6 and drawings 2, 50, 51, 56, 57, 62, 65, or distributed

along several positions as shown in other cases such as for instance drawings 52 or 58.

[0023] In some preferred embodiments, larger rectangles have the same width (for instance Fig.1 and Fig. 7) but in other preferred embodiments they do not (see for instance drawings 64 through 67 in Fig.8). Polygons and/or strips are linearly arranged with respect an straight axis (see for instance 56 and 57) in some embodiments while in others embodiments they are not centered with respect to said axis. Said strips can also be placed at the edges of the overall ground-plane as in, for instance, drawing 55, and they can even become arranged in a zigzag or meandering pattern as in drawing 58 where the strips are alternatively and sequentially placed at the two longer edges of the overall ground-plane.

[0024] Some embodiments like 59 and 61, where several conducting surfaces are coupled by means of more than one strip or conducting polygon, are preferred when a multiband or broadband behaviour is to be enhanced. Said multiple strip arrangement allows multiple resonant frequencies which can be used as separate bands or as a broad-band if they are properly coupled together. Also, said multiband or broad-band behaviour can be obtained by shaping said strips with different lengths within the same gap.

[0025] In other preferred embodiments, conducting surfaces are connected by means of strips with SFC shapes, as in the examples shown in Fig. 3, 4, 5, 10, 11, 14, or 15. In said configurations, SFC curves can cover even more than the 50% of the area covered by said ground-plane as it happens in the cases of Fig. 14. In other cases, the gap between conducting surfaces themselves is shaped as an SFC curve as shown in Fig. 12 or 13. In some embodiments, SFC curves feature a box-counting dimension larger than one (at least for an octave in the abscissa of the log-log graph used in the box-counting algorithm) and can approach the so called Hilbert or Peano curves or even some ideally infinite curves known as fractal curves.

[0026] Another preferred embodiment of multilevel and space-filling ground-plane is the monopole configuration as shown in Figure 4. Figure 4A shows a prior art antenna system 32 composed by a monopole radiating element 33 over a common and conventional solid surface ground-plane 34. Prior art patents and scientific publications have dealt with several one-piece solid surfaces, being the most common ones circular and rectangular. However, in the new ground-plane configuration of our invention, multilevel and space-filling structures can be used to enhance either the return loss, or radiation efficiency, or gain, or bandwidth, or a combination of all the above, while reducing the size compared to antennas with a solid ground-plane. Figure 4B shows a monopole antenna system 35 composed by a radiating element 36 and a multilevel and space-filling ground-plane 37. Here, the arm of the monopole 33 is presented as a cylinder, but any other structure can be obviously taken instead (even helical, zigzag, meandering, fractal, or SFC con-

figurations, to name a few).

[0027] To illustrate that several modifications of the antenna can be done based on the same principle and spirit of the present invention, another preferred embodiment example is shown in Figure 5, based on the patch configuration. Figure 5A shows an antenna system 38 that consist of a conventional patch antenna with a polygonal patch 39 (squared, triangular, pentagonal, hexagonal, rectangular, or even circular, multilevel, or fractal, to name just a few examples) and a common and conventional one-piece solid ground-plane 40. Figure 5B shows a patch antenna system 41 that consists of a radiating element 42 (that can have any shape or size) and a multilevel and space-filling ground-plane 43. The ground-plane 43 being showed in the drawing is just an example of how multilevel and space-filling structures can be implemented on a ground-plane. Preferably, the antenna, the ground-plane or both are disposed on a dielectric substrate. This may be achieved, for instance, by etching techniques as used to produce PCBs, or by printing the antenna and the ground-plane onto the substrate using a conductive ink. A low-loss dielectric substrate (such as glass-fibre, a teflon substrate such as Cuclad® or other commercial materials such as Rogers® 4003 well-known in the art) can be placed between said patch and ground-plane. Other dielectric materials with similar properties may be substituted above without departing from the intent of the present invention. As an alternative way to etching the antenna and the ground-plane out of copper or any other metal, it is also possible to manufacture the antenna system by printing it using conductive ink. The antenna feeding scheme can be taken to be any of the well-known schemes used in prior art patch antennas as well, for instance: a coaxial cable with the outer conductor connected to the ground-plane and the inner conductor connected to the patch at the desired input resistance point; a microstrip transmission line sharing the same ground-plane as the antenna with the strip capacitively coupled to the patch and located at a distance below the patch, or in another embodiment with the strip placed below the ground-plane and coupled to the patch through an slot, and even a microstrip transmission line with the trip co-planar to the patch. All these mechanisms are well known from prior art and do not constitute an essential part of the present invention. The essential part of the present invention is the shape of the ground-plane (multilevel and/or space-filling), which contributes to reducing the size with respect to prior art configurations, as well as enhancing antenna bandwidth, VSWR, and radiation efficiency.

[0028] It is interesting to notice that the advantage of the ground-plane geometry can be used in shaping the radiating element in a substantially similar way. This way, a symmetrical or quasymmetrical configuration is obtained where the combined effect of the resonances of the ground-plane and radiating element is used to enhance the antenna behaviour. A particular example of a microstrip (127) and monopole (128) antennas using said

configuration and design in drawing 61 is shown in Fig. 19, but it appears clear to any skilled in the art that many other geometries (other than 61) could be used instead within the same spirit of the invention. Drawing 127 shows a particular configuration with a short-circuited patch (129) with shorting post, feeding point 132 and said ground-plane 61, but other configurations with no shorting post, pin, or strip are included in the same family of designs. In the particular design of the monopole (128), the feeding post is 133.

[0029] The above-described embodiments of the invention are presented by way of example only and do not limit the invention. Having illustrated and described the principles of our invention in several preferred embodiments thereof, it should be readily apparent to those skilled in the art that the invention can be modified in arrangement and detail without departing from such principles.

Claims

1. A ground-plane for an antenna device **characterized in that** said ground-plane includes at least two conducting surfaces, said conducting surfaces being connected by at least a conducting strip, said strip being narrower than the width of any of said two conducting surfaces.
2. A ground-plane for an antenna device according to claim 1, wherein said conducting surfaces are laying over a common planar or curved surface.
3. A ground-plane for an antenna device according to claim 1 or 2, wherein two edges of at least two conducting surfaces are placed substantially parallel to each other and said strip connecting said two surfaces is placed substantially centered with respect to the gap defined by said two substantially parallel edges.
4. A ground-plane for an antenna device according to claim 1, 2, or 3, wherein the ground-plane includes at least three conducting surfaces, in which one pair of any of two adjacent conducting surfaces are connected by means of at least a conducting strip, and the rest of pairs of adjacent conducting surfaces are electromagnetically connected by means of a capacitive effect or by direct contact provided by at least a conducting strip.
5. A ground-plane for an antenna device according to claim 4, wherein said strips are substantially aligned along a straight axis.
6. A ground-plane for an antenna device according to claim 4, wherein said strips are not aligned along a straight axis.
7. A ground-plane for an antenna device according to claim 1, 2, or 4, including at least two conducting strips, both strips connecting at least two of said conducting surfaces at least at two points located at both edges of said conducting surfaces.
8. A ground-plane for an antenna device according to claim 1, 2, 4, 6, or 7, wherein at least one of said strips is aligned along one of the edges defining the external perimeter of said ground-plane.
9. A ground-plane for an antenna device according to claim 2, said ground-plane comprising a plurality of conducting surfaces laying on the same planar or curved surface, wherein at least two of said conducting surfaces are connected by means of a conducting strip.
10. A ground-plane for an antenna device according to claim 1, 2, 3, 4, 5, 6, 7, 8, or 9, wherein each couple of adjacent conducting surfaces are connected by means of at least a conducting strip.
11. A ground-plane for antenna device according to claim 1, 2, 3, 4, 5, 6, 7, 8, 9, or 10, wherein all the conducting surfaces defining said ground-plane have a substantially rectangular shape, said rectangular shapes being sequentially aligned along a straight axis, each pair of rectangular shapes defining a gap between them, at least a couple of opposite edges of at least one of said gaps being connected by at least a conducting strip.
12. A ground-plane for an antenna device according to claim 1, 2, 4, 6, 8, 9, 10, or 11 wherein all the conducting surfaces defining said ground-plane have the same horizontal width and are sequentially aligned along a straight vertical axis, wherein each pair of adjacent conducting surfaces define a gap between them, wherein each pair of adjacent conducting surfaces are connected across said gap by means of a conducting strip, said strip being aligned along an edge of the external perimeter of said ground-plane, said edge being alternatively and sequentially chosen at the right and left sides with respect of a vertical axis crossing the center of the ground-plane.
13. A ground-plane for an antenna device according to claim 1, 2, 3, 4, 5, 6, 7, 8, 9, 10, 11, or 12, wherein at least one of the strips connecting two of said conducting surfaces is shaped as a zigzag or meandering curve.
14. A ground-plane for an antenna device according to claim 1, 2, 3, 4, 5, 6, 7, 8, 9, 10, 11, 12, or 13, wherein at least one of the conducting surfaces, and/or at least one of the conducting strips of said ground-

- plane is shaped as Space-Filling Curve (SFC), being said Space-Filling Curve composed by at least ten connected straight segments, wherein said segments are smaller than a tenth of the operating free-space wave length and they are spatially arranged in such a way that none of said adjacent and connected segments form another longer straight segment, wherein non of said segments intersect to each other except optionally at the tips of the curve, wherein the corners formed by each pair of said adjacent segments can be optionally rounded or smoothed otherwise, and wherein the curve can be optionally periodic along a fixed straight direction of space if, and only if, the period is defined by a non-periodic curve composed by at least ten connected segments and no pair of said adjacent and connected segments define a straight longer segment.
- 5
- 10
- 15
- 20
- 25
- 30
- 35
- 40
- 45
- 50
- 55
15. A ground-plane for an antenna device according to claim 14, wherein at least one of its parts is shaped as a SFC, wherein said SFC features a box-counting dimension larger than one, being said box-counting dimension computed as usual as the slope of the straight portion of a log-log graph, wherein such a straight portion is substantially defined as a straight segment over at least an octave of scales on the horizontal axis of the log-log graph.
16. A ground-plane for an antenna device according to claim 14 or 15, wherein at least one of its parts is shaped either as a Hilbert, Peano, SZ, ZZ, HilbertZZ, Peanoinc, Peanodec, or PeanoZZ curve.
17. A ground-plane for an antenna device according to claim 14, 15, or 16, wherein at least one of the strips connecting two of said conducting surfaces is shaped as an SFC.
18. A ground-plane for an antenna device according to claim 1, 2, 3, 4, 5, 6, 7, 8, 9, 10, 11, 12, 13, 14, 15, 16, or 17, wherein at least one of the gaps between at least two of said conducting surfaces includes at least two conducting strips of different length.
19. A ground-plane for an antenna device according to claim 14, 15, 16, or 17, wherein at least a portion of the gap between at least two of said conducting surfaces defining the ground-plane is shaped as an SFC.
20. A ground-plane for an antenna device according to claim 14, 15, 16, 17, 18, or 19, wherein at least 50% of surface covered by said ground-plane is filled out by means of a strip, said strip being shaped as an SFC.
21. A ground-plane for an antenna device according to claim 1, 2, 3, 4, 5, 6, 7, 8, 9, 10, 11, 12, 13, 14, 15, 16, 17, 18, 19, or 20, wherein at least a portion of the geometry of said ground-plane is a multilevel structure, said multilevel structure including a set of conducting polygons, all of said polygons featuring the same number of sides, wherein said polygons are electromagnetically coupled either by means of a capacitive coupling or ohmic contact, wherein the contact region between directly connected polygons is narrower than 50% of the perimeter of said polygons in at least 75% of said polygons defining said conducting ground-plane.
22. A ground-plane for antenna device according to any of the claims 1 through 21, wherein the shape of the perimeter of said ground-plane, the shape of the conducting surfaces, or both kinds of elements included in said ground-plane are square, rectangular, triangular, circular, semi-circular, elliptical, or semi-elliptical.
23. A ground-plane for an antenna device according to the preceding claims, wherein the antenna device is a handheld wireless device.
24. A ground-plane for an antenna device according to any of the claims 1 through 22, wherein the antenna device is a microstrip patch antenna.
25. A ground-plane for an antenna device according to any of the claims 1 through 22, wherein the antenna device is a Planar Inverted-F Antenna (PIFA).
26. A ground-plane for an antenna device according to any of the claims 1 through 22, wherein the antenna device is a monopole antenna.
27. An antenna device including a ground-plane according to any of the preceding claims, wherein the antenna is smaller than a half of the free-space operating wavelength.
28. An antenna device according to any of the claims 1 through 27, wherein the antenna is smaller compared to another antenna with the same radiating element but with a conventional solid ground-plane.
29. An antenna device according to any of the claims 1 through 28, wherein the antenna features a broader bandwidth with respect to another antenna with the same radiating element but with a conventional solid ground-plane of the same size and external perimeter shape.
30. An antenna device according to any of the claims 1 through 29, wherein the antenna features a multi-band behavior.
31. An antenna device according to claims 24, 25, 26,

27, 28, or 29, wherein the antenna is used to provide coverage in micro-cells or pico-cells at least one of the cellular systems AMPS, GSM900, GSM1800, PCS1900, UMTS, CDMA, or at least a WLAN system such as IEEE 802.11, Bluetooth, or a combination of them. 5

32. An antenna device according to claims 24, 25, 26, 27, 28, or 29, wherein the antenna is mounted inside the rear-view mirror of a motor vehicle to provide coverage to at least one of the cellular systems AMPS, GSM900, GSM1800, PCS1900, UMTS, CDMA, or at least a WLAN system such as IEEE802.11, Bluetooth, or a combination of them. 10
15

33. An antenna device according to claims 24, 25, 26, 27, 28, or 29, wherein the antenna is mounted inside the keyless door lock operation device.

34. An antenna device according to claims 1 through 22 **characterized in that** the radiating element has substantially the same shape as the ground-plane, said radiating element being placed parallel or orthogonal to said ground-plane. 20
25

30

35

40

45

50

55

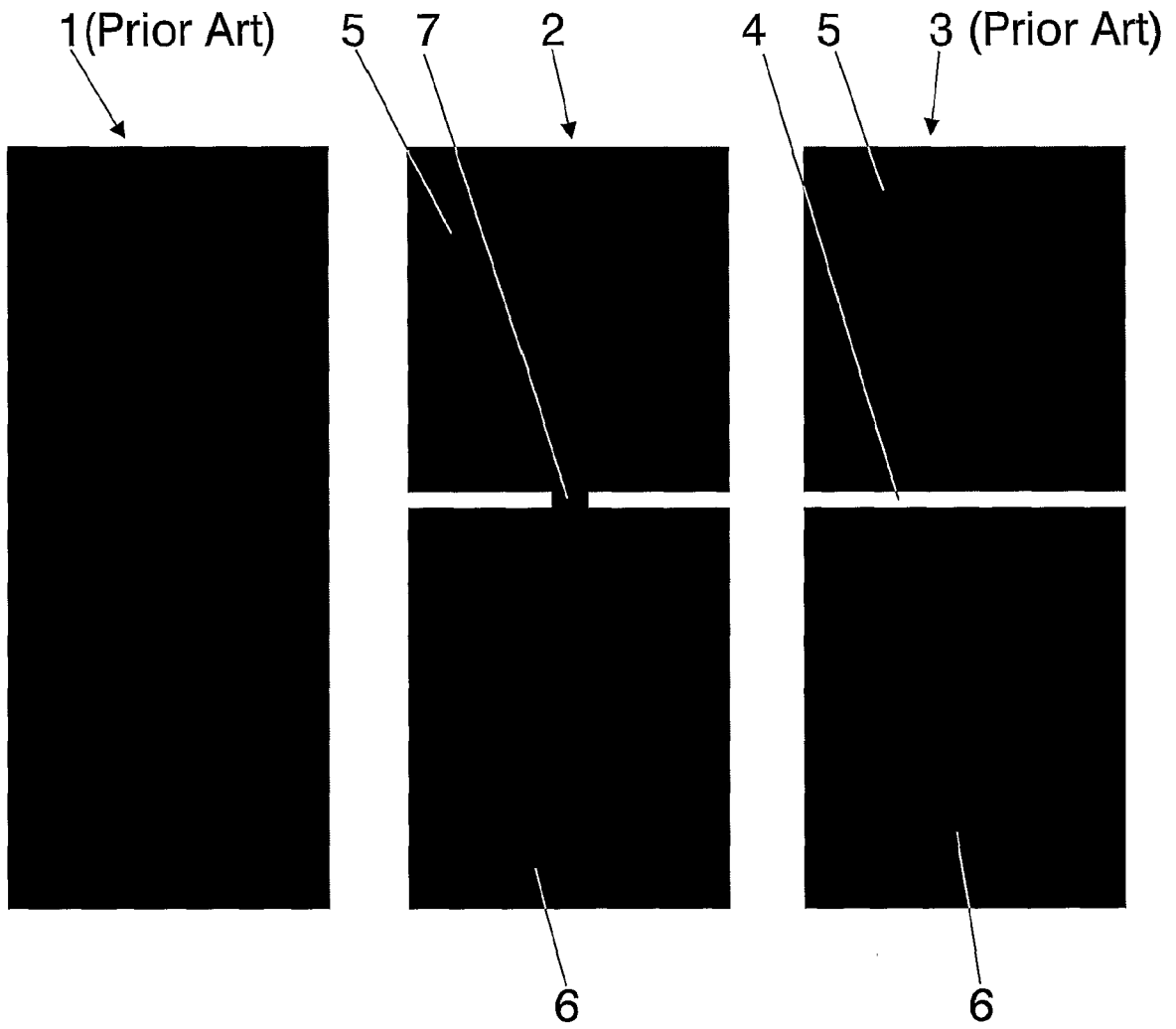

FIG. 1

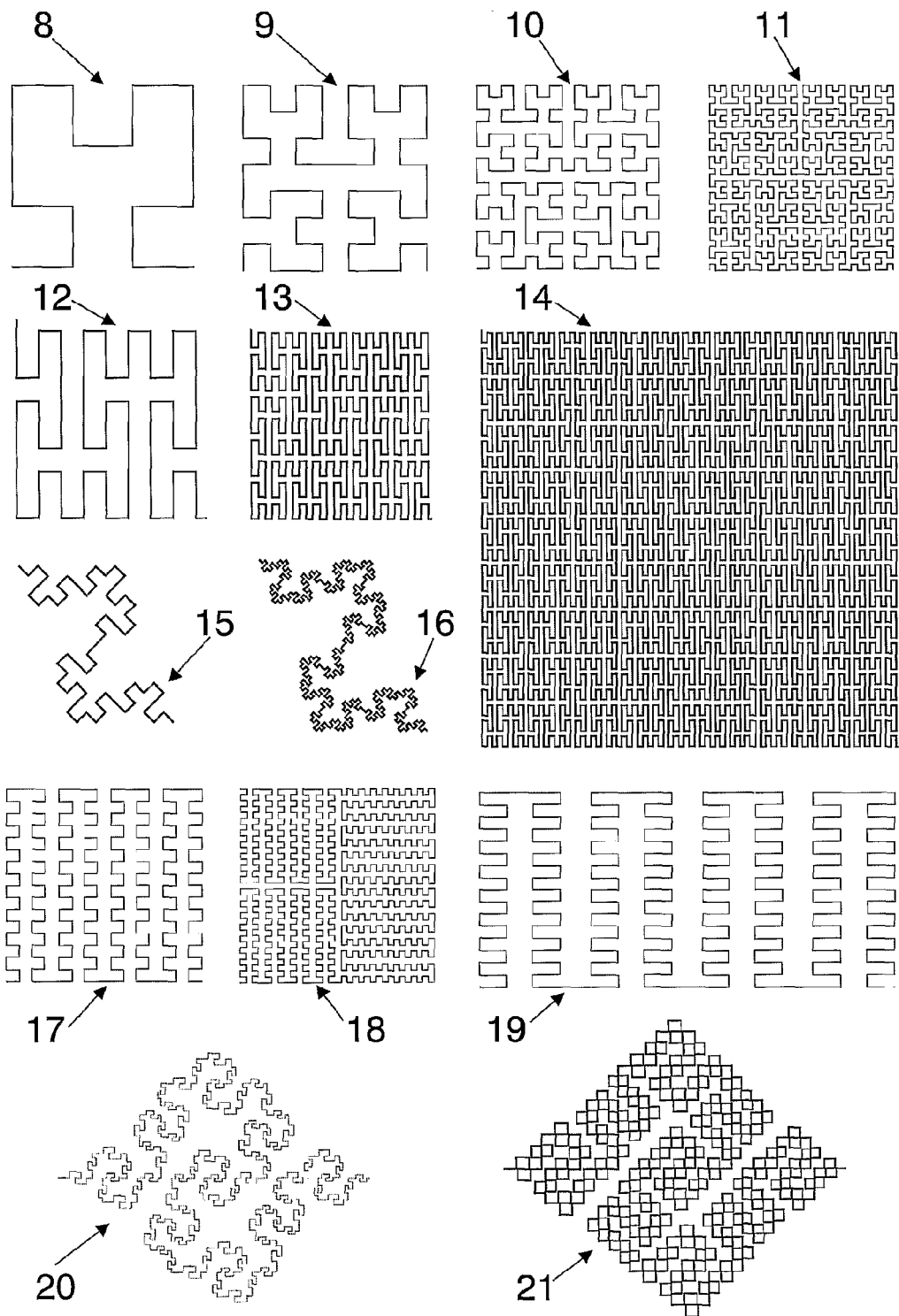

FIG.2

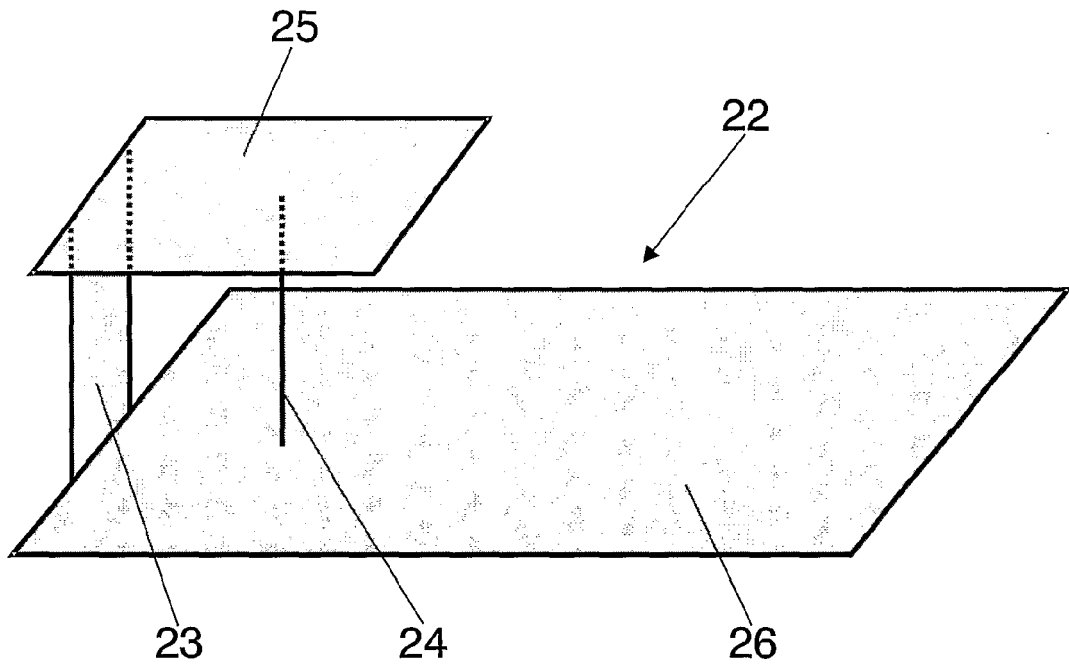

FIG. 3A (Prior Art)

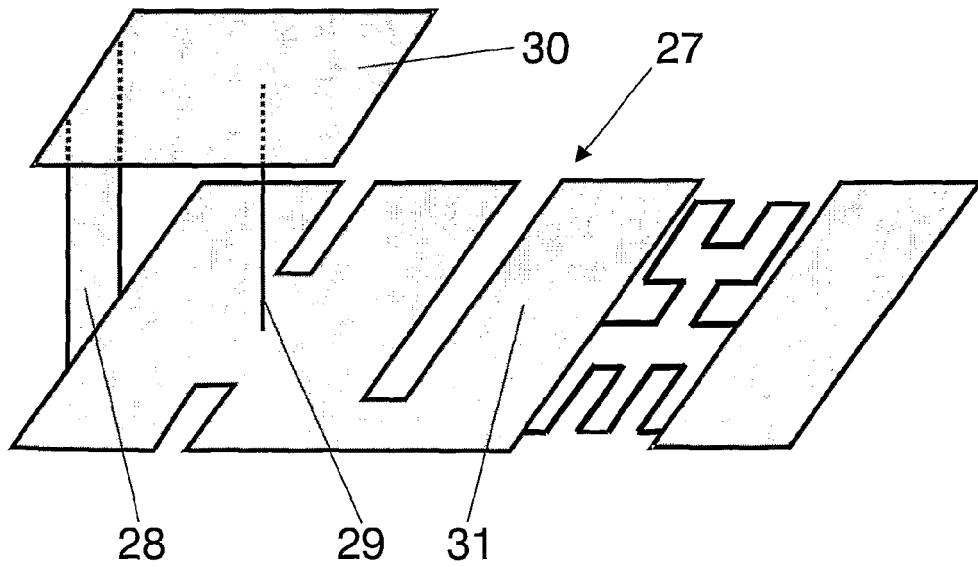

FIG. 3B

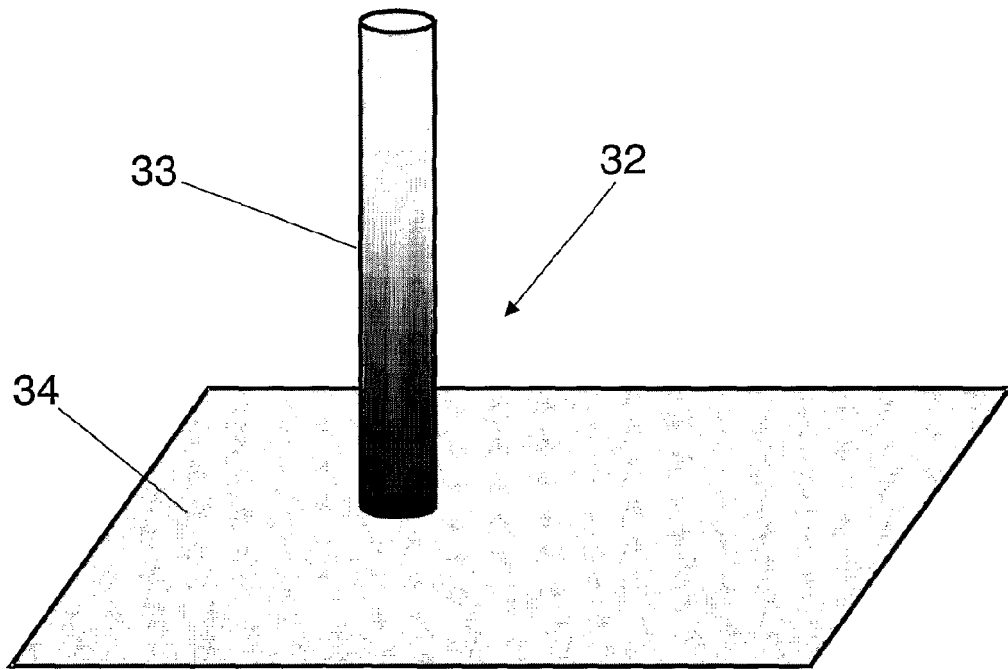

FIG. 4A (Prior Art)

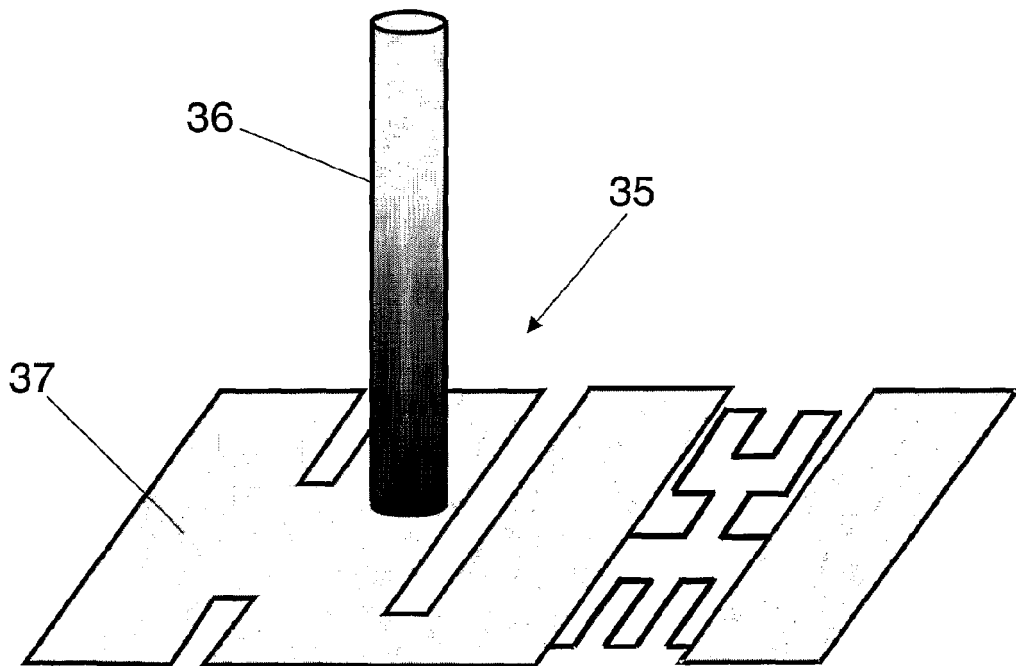

FIG. 4B

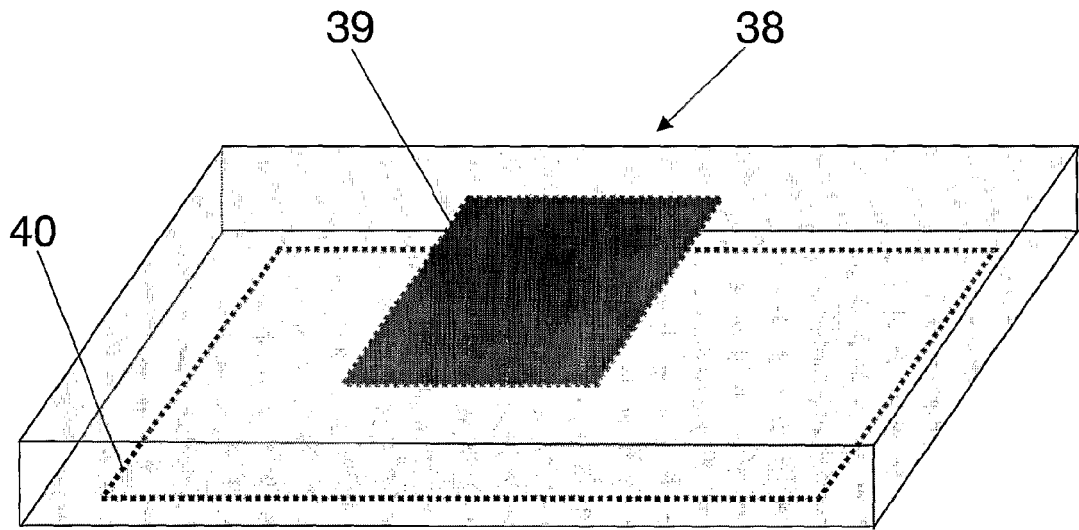

FIG. 5A (Prior Art)

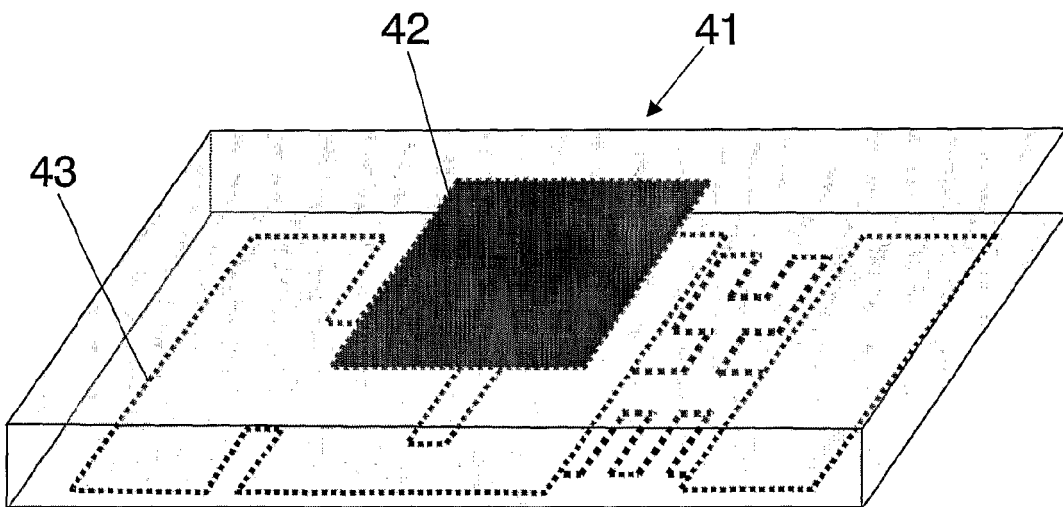

FIG. 5B

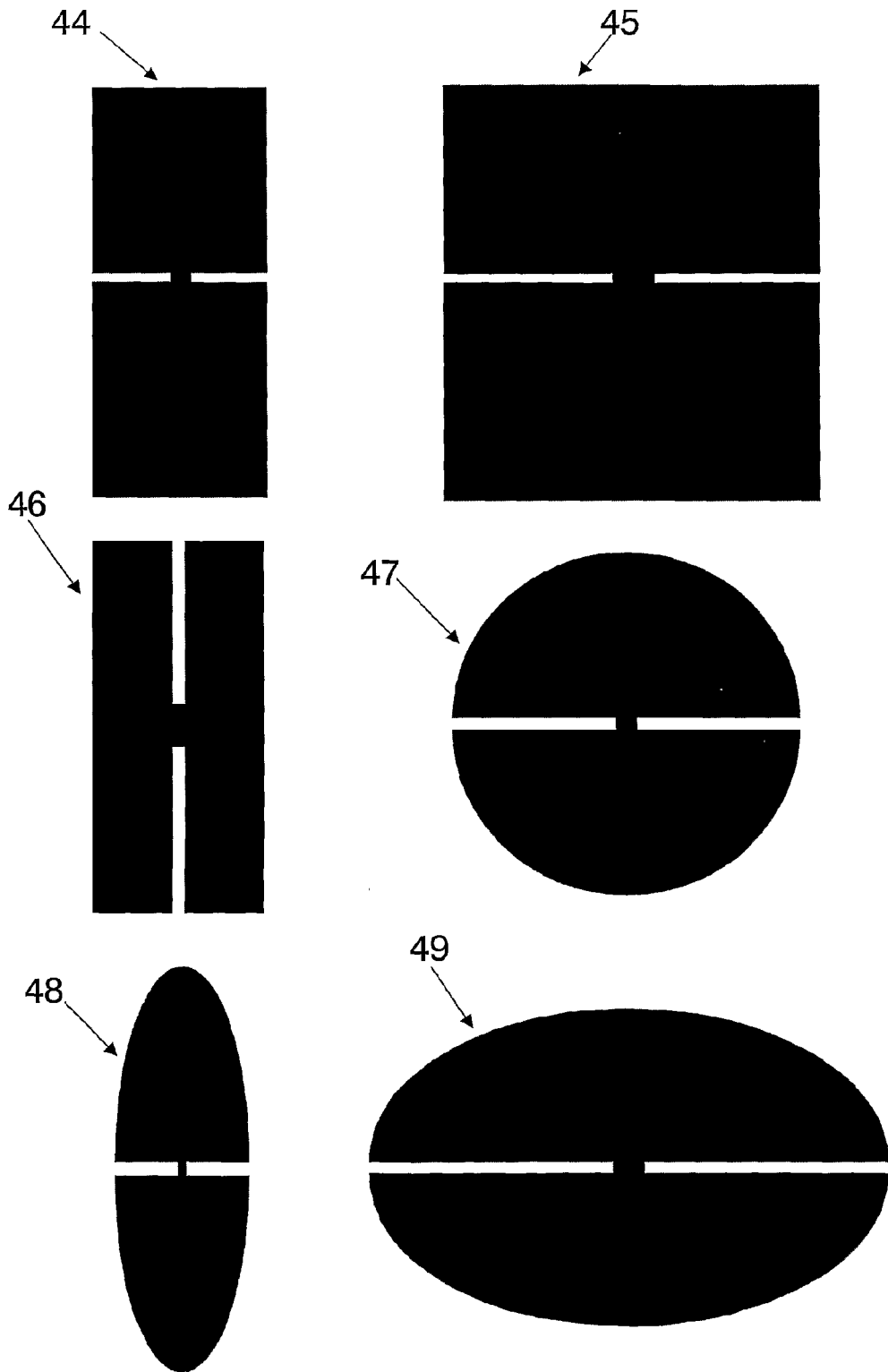

FIG.6

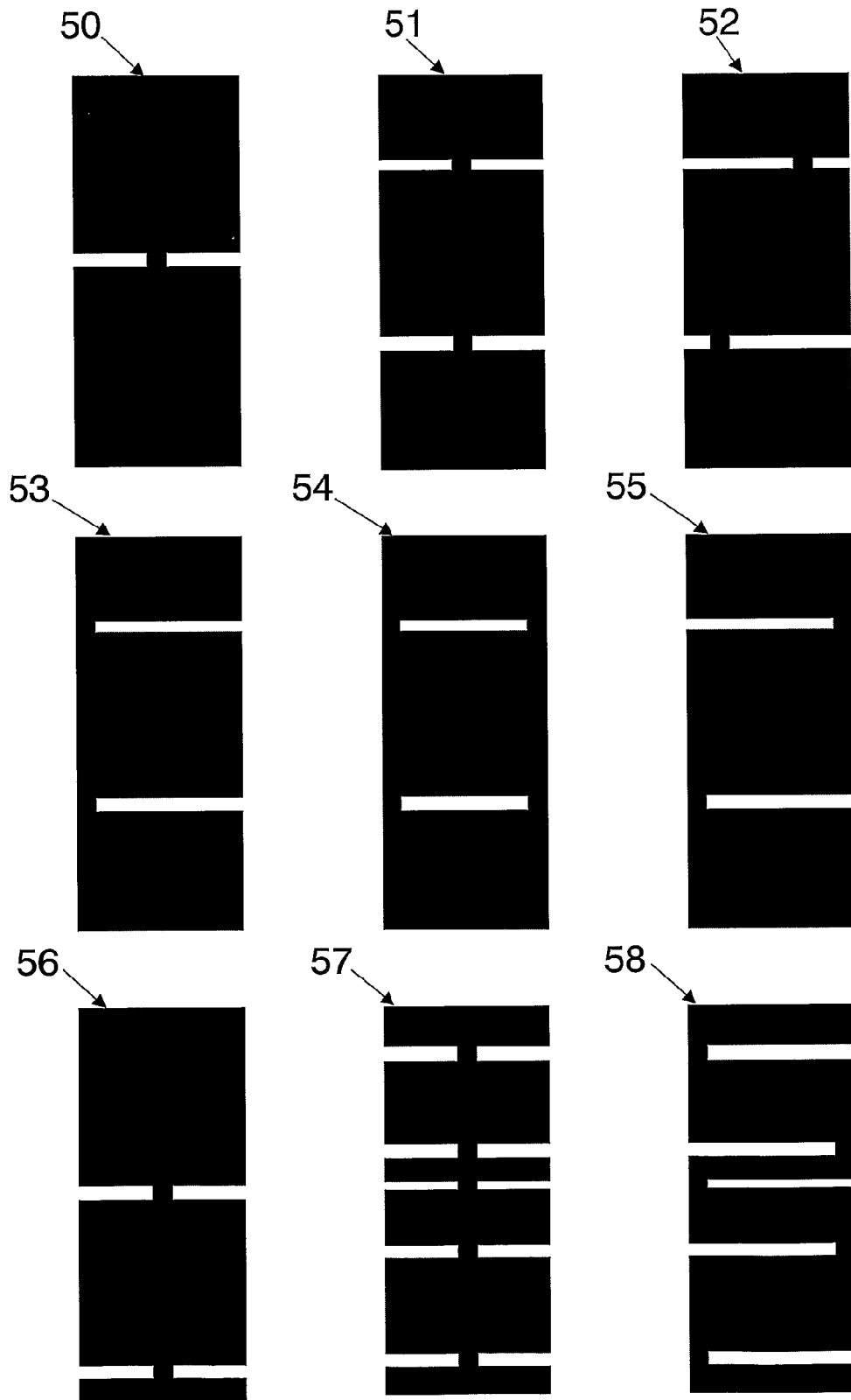

FIG.7

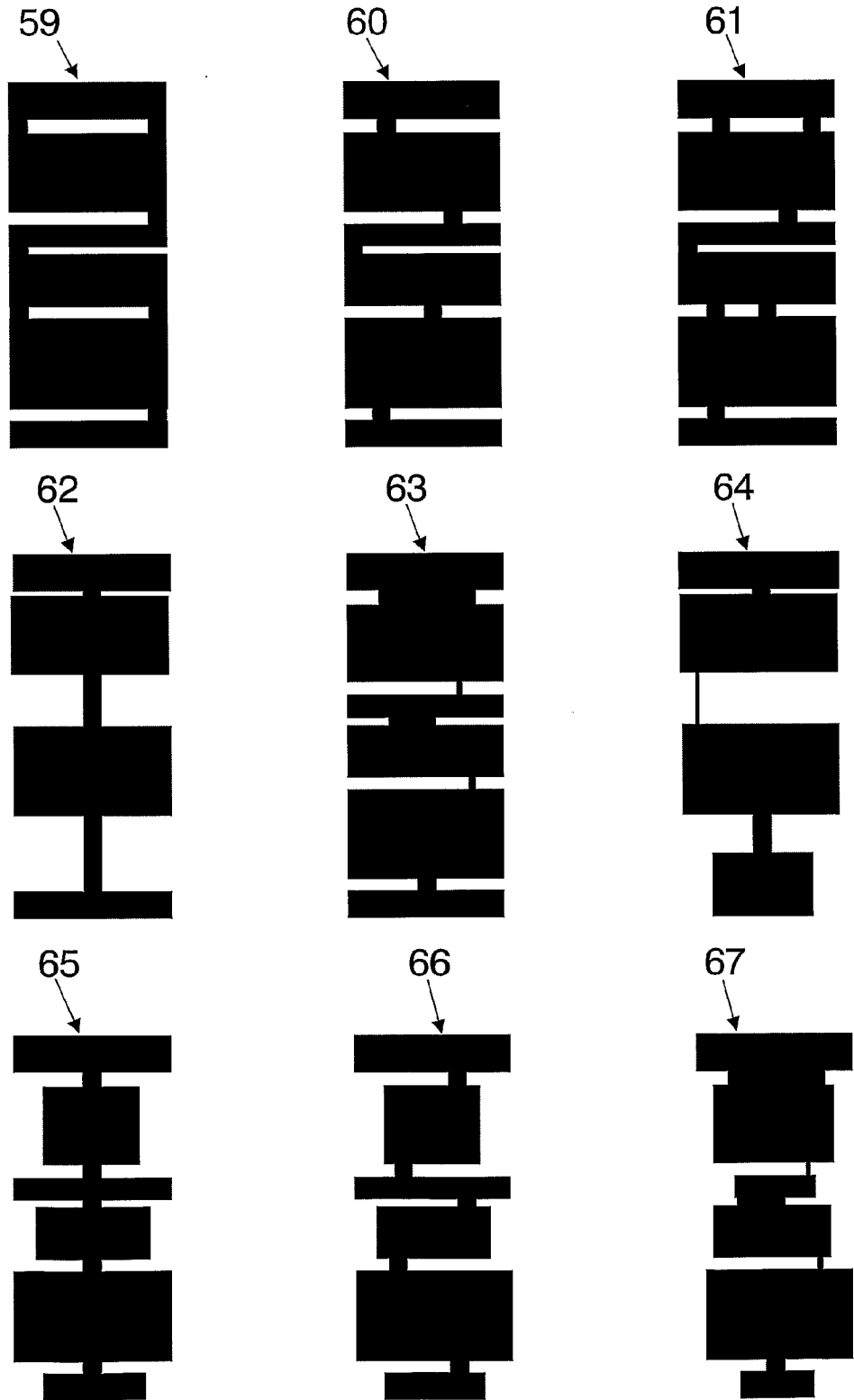

FIG.8

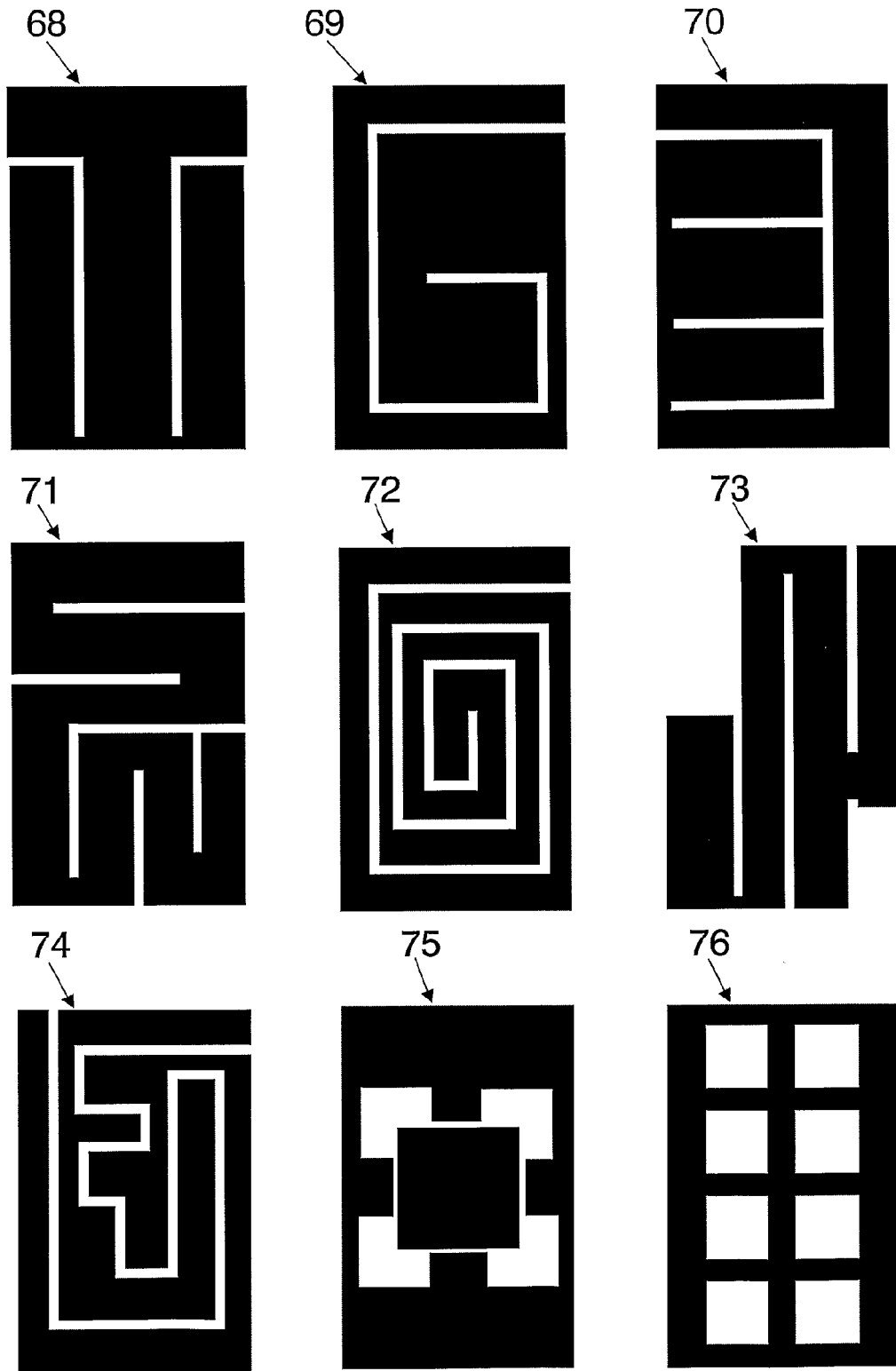

FIG.9

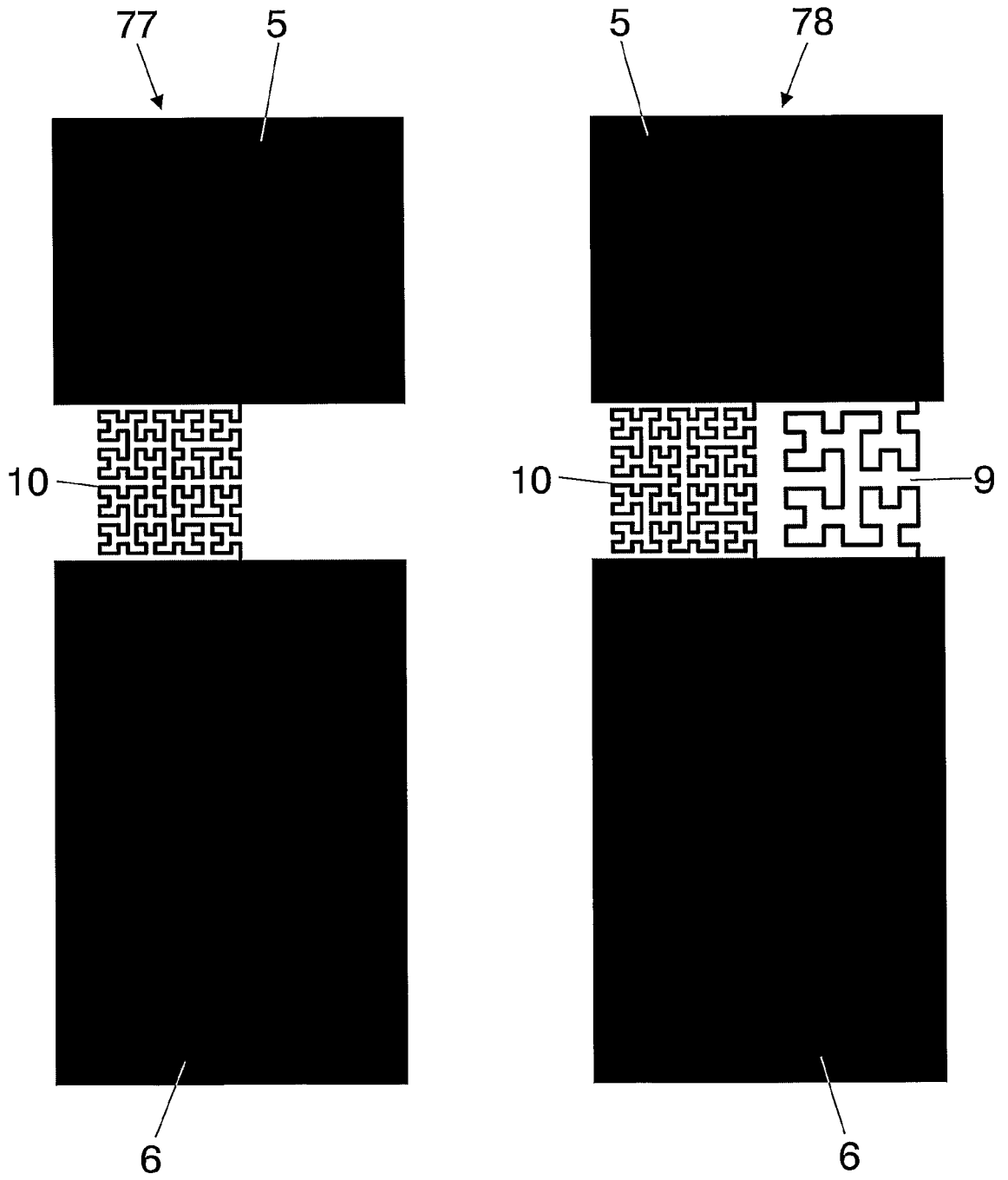

FIG.10

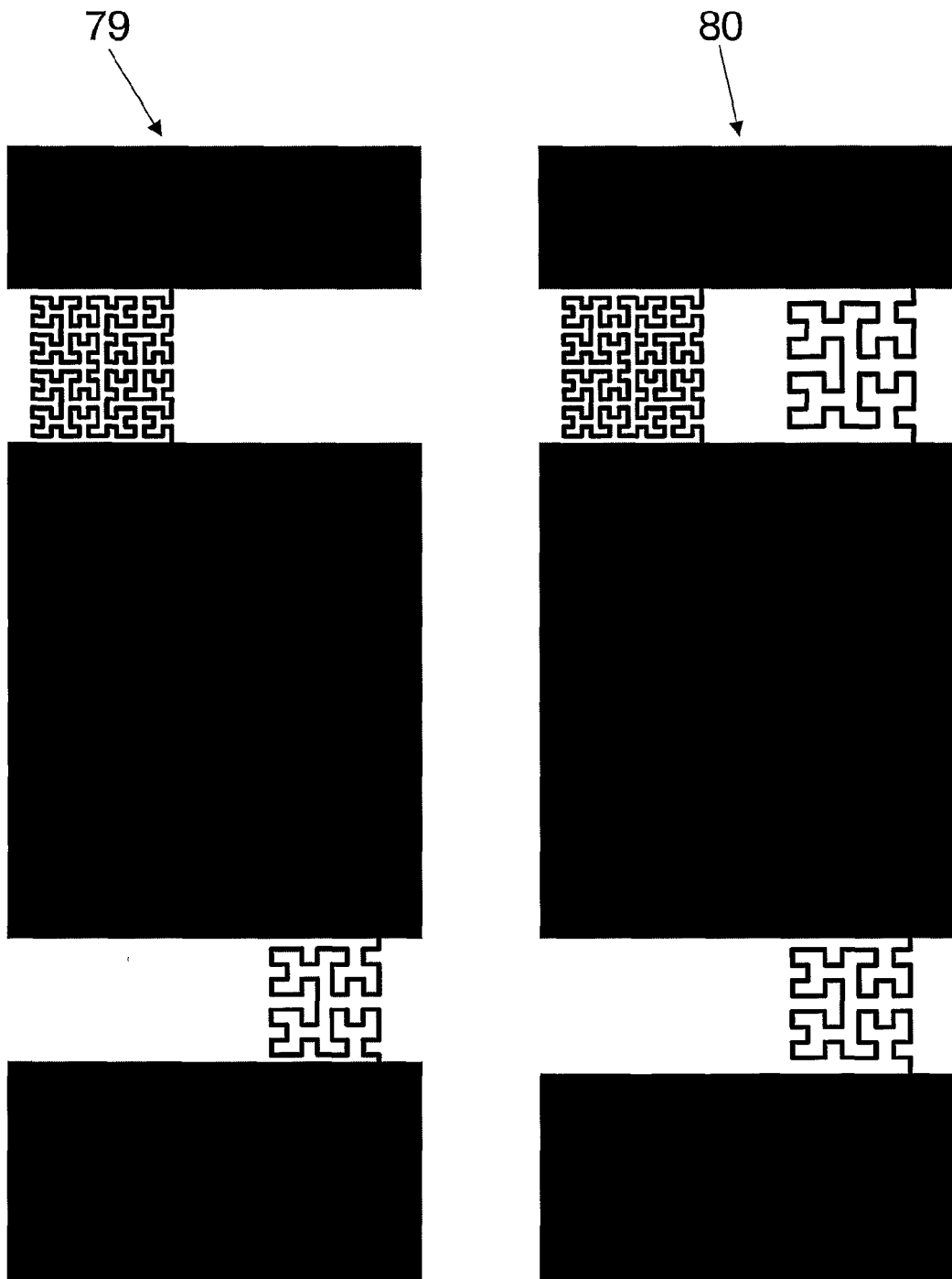

FIG.11

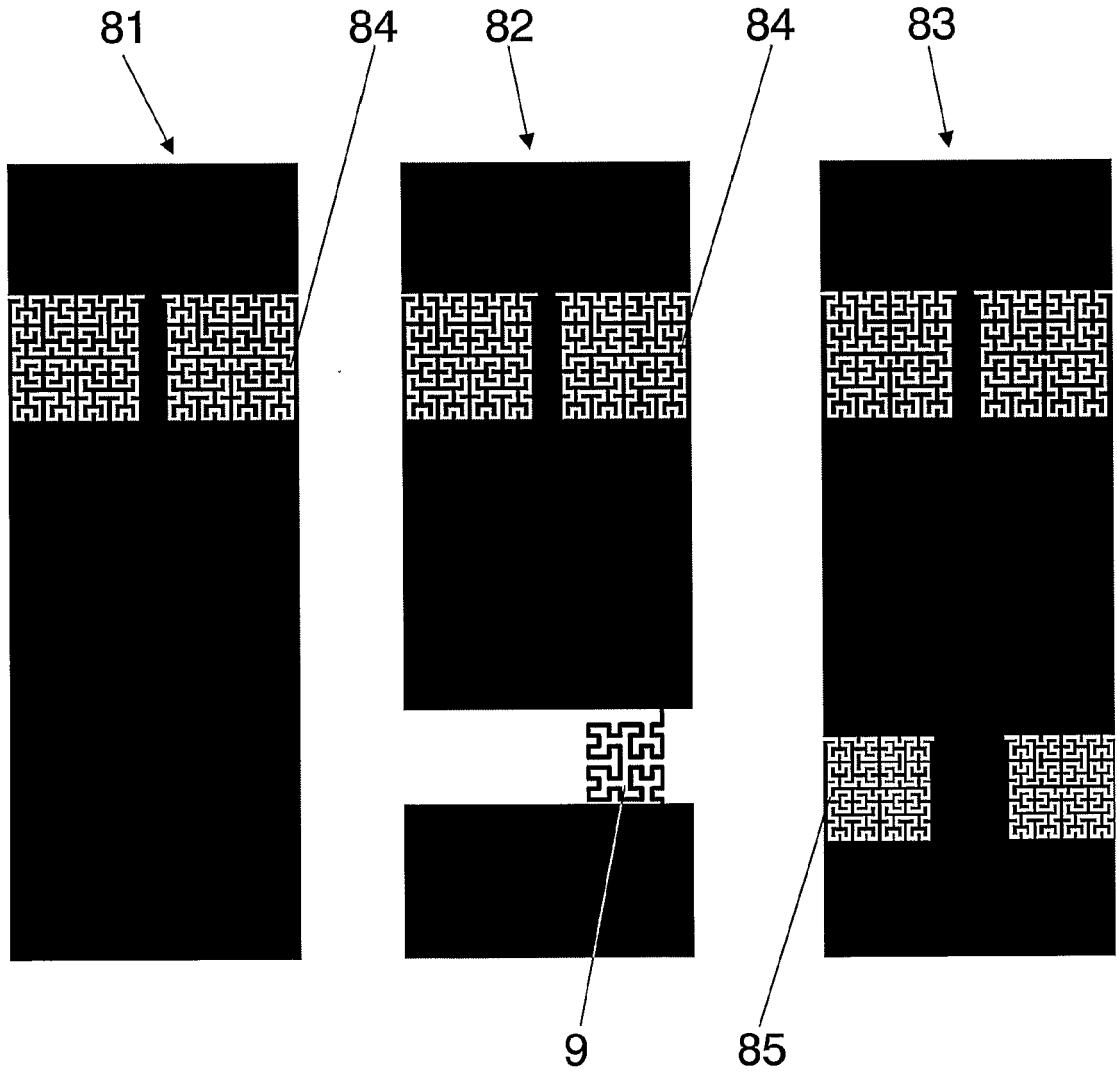

FIG. 12

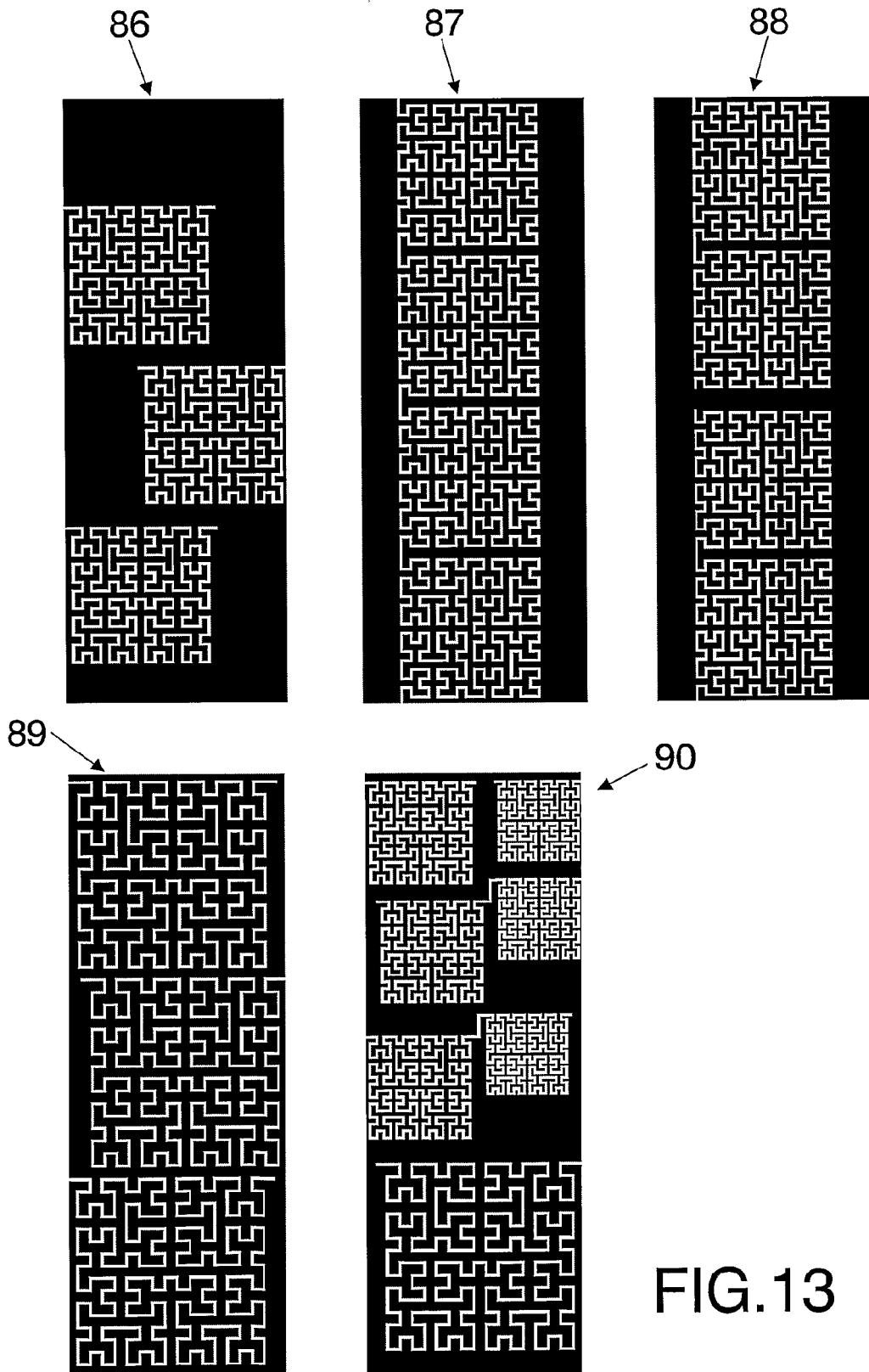

FIG.13

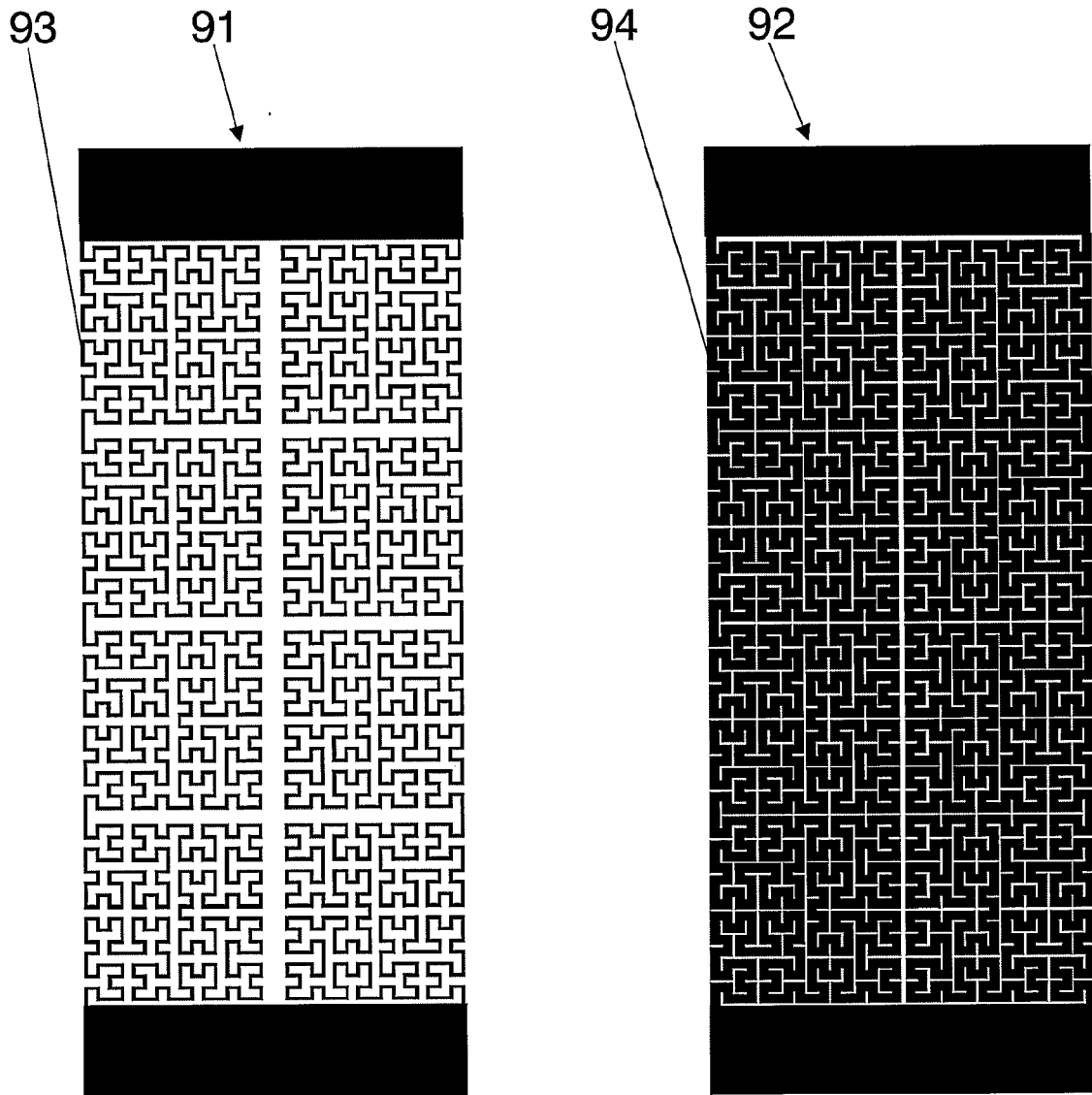

FIG.14

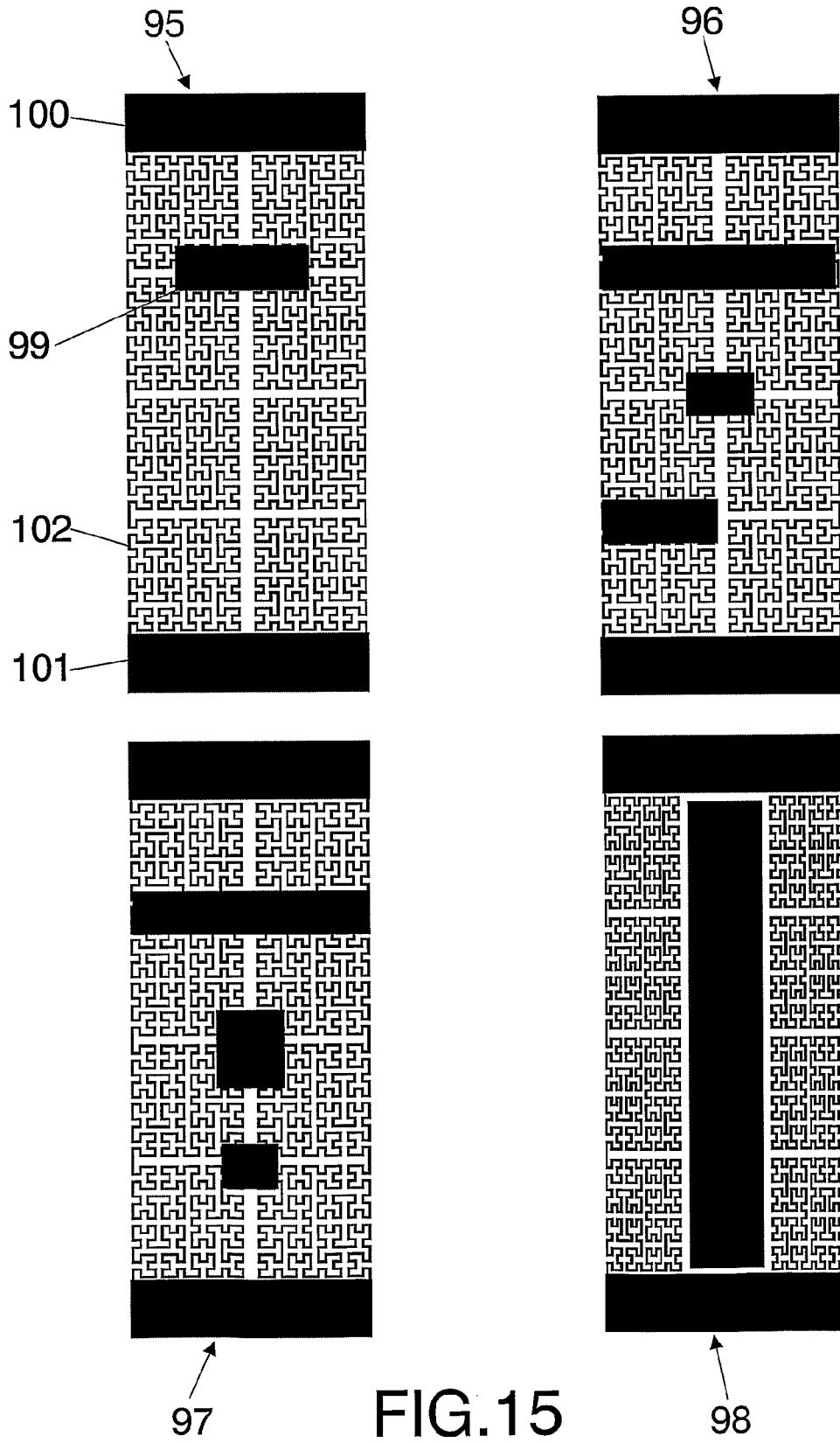

FIG. 15

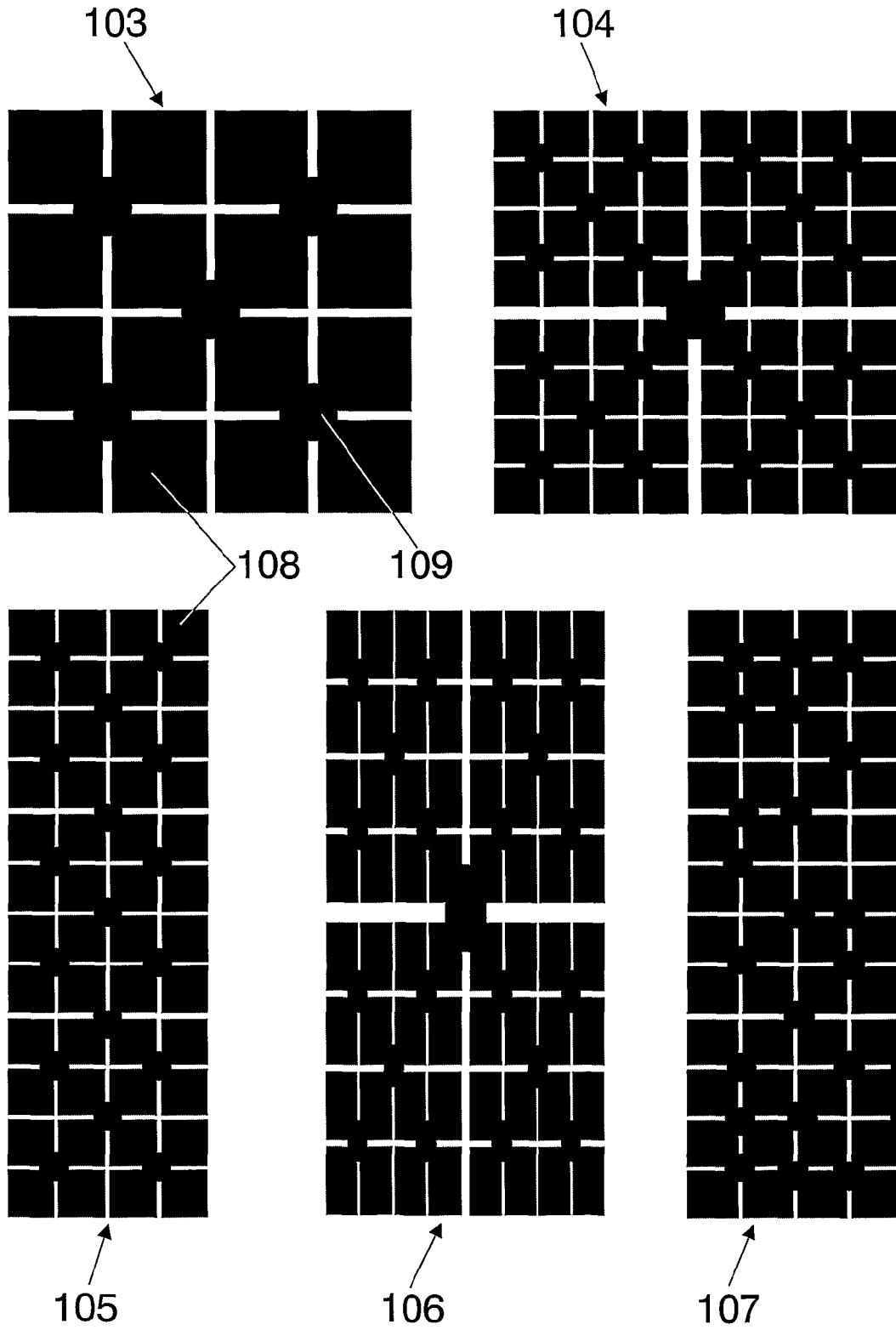

FIG.16

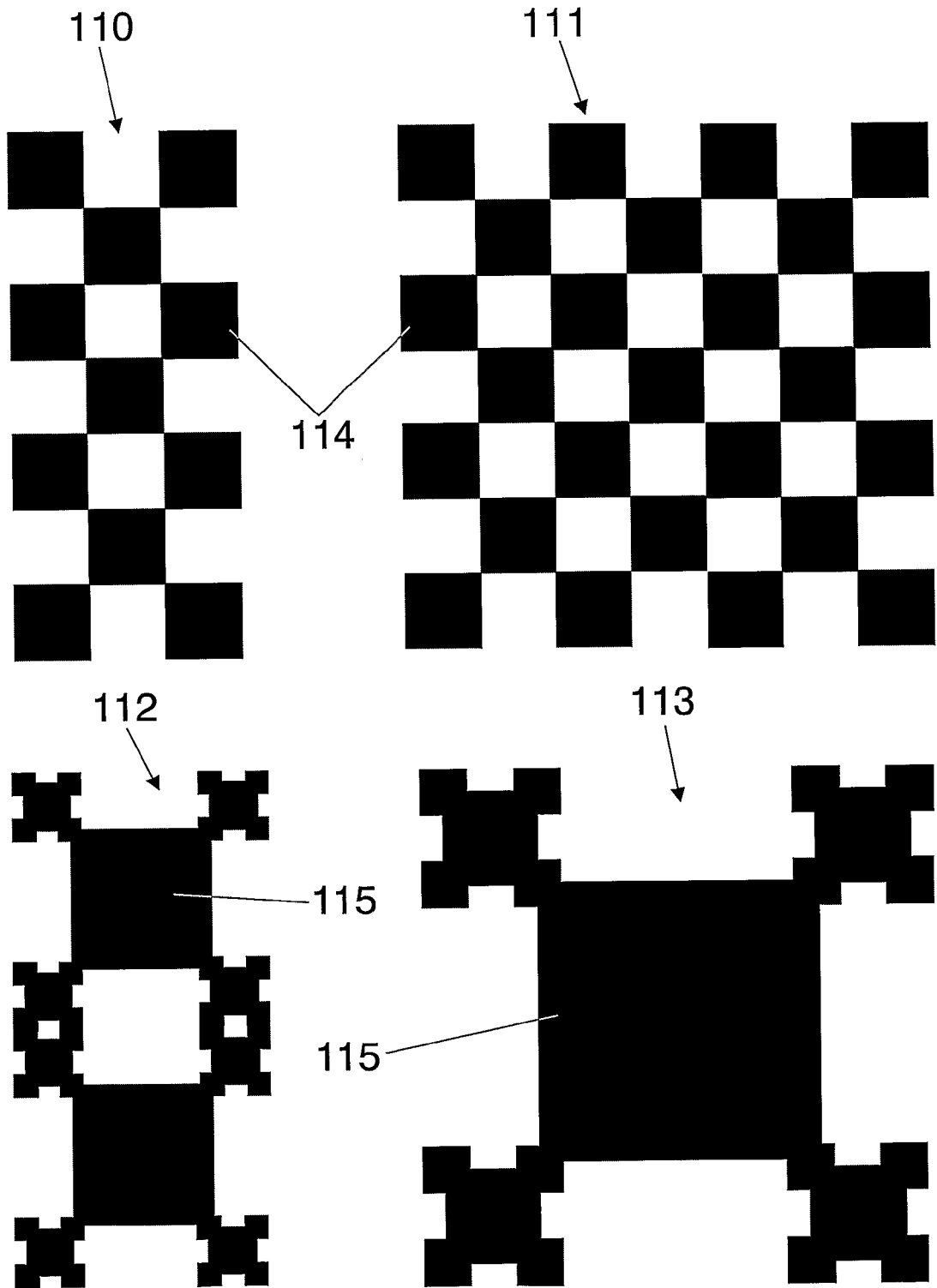

FIG.17

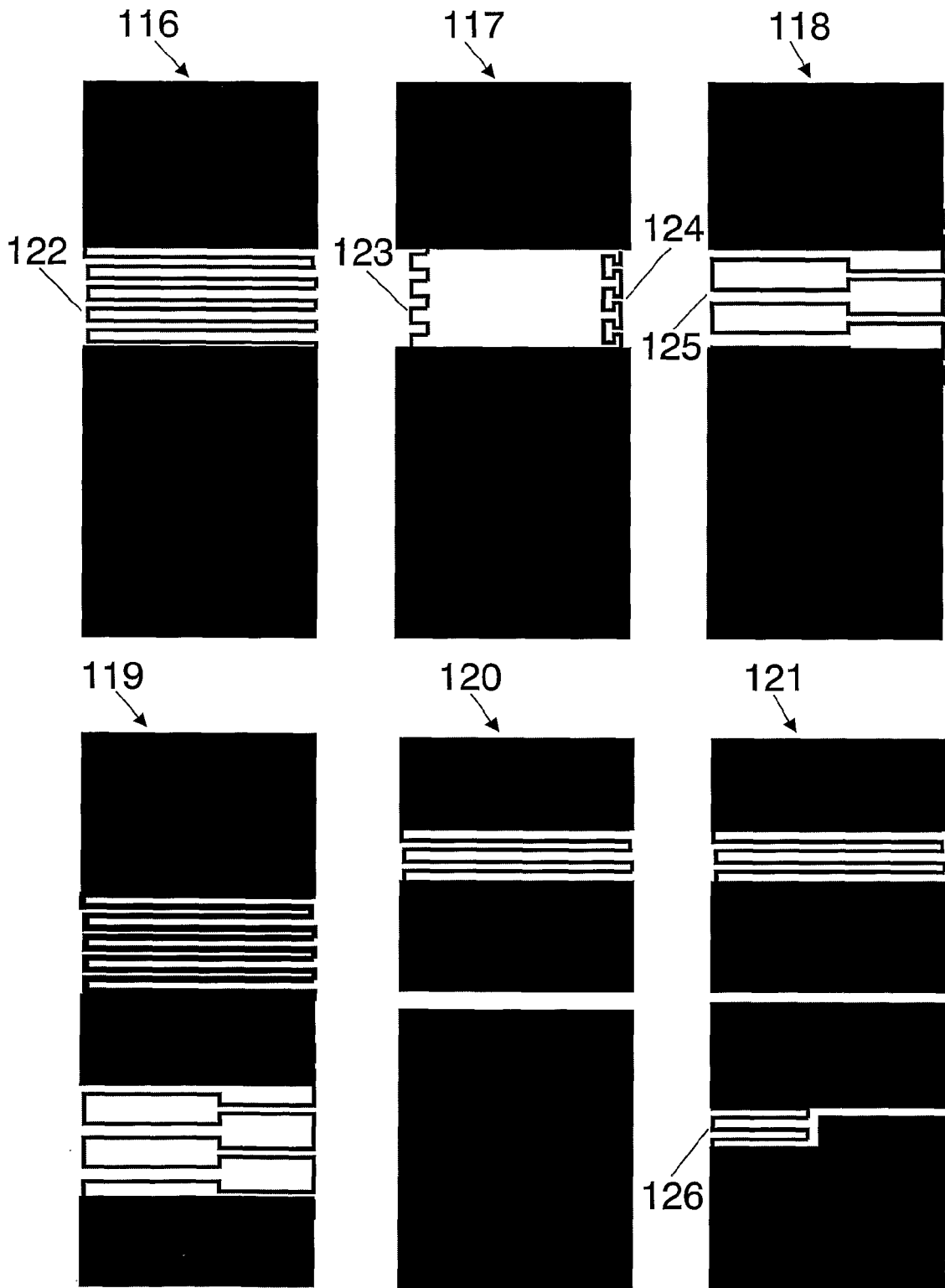

FIG.18

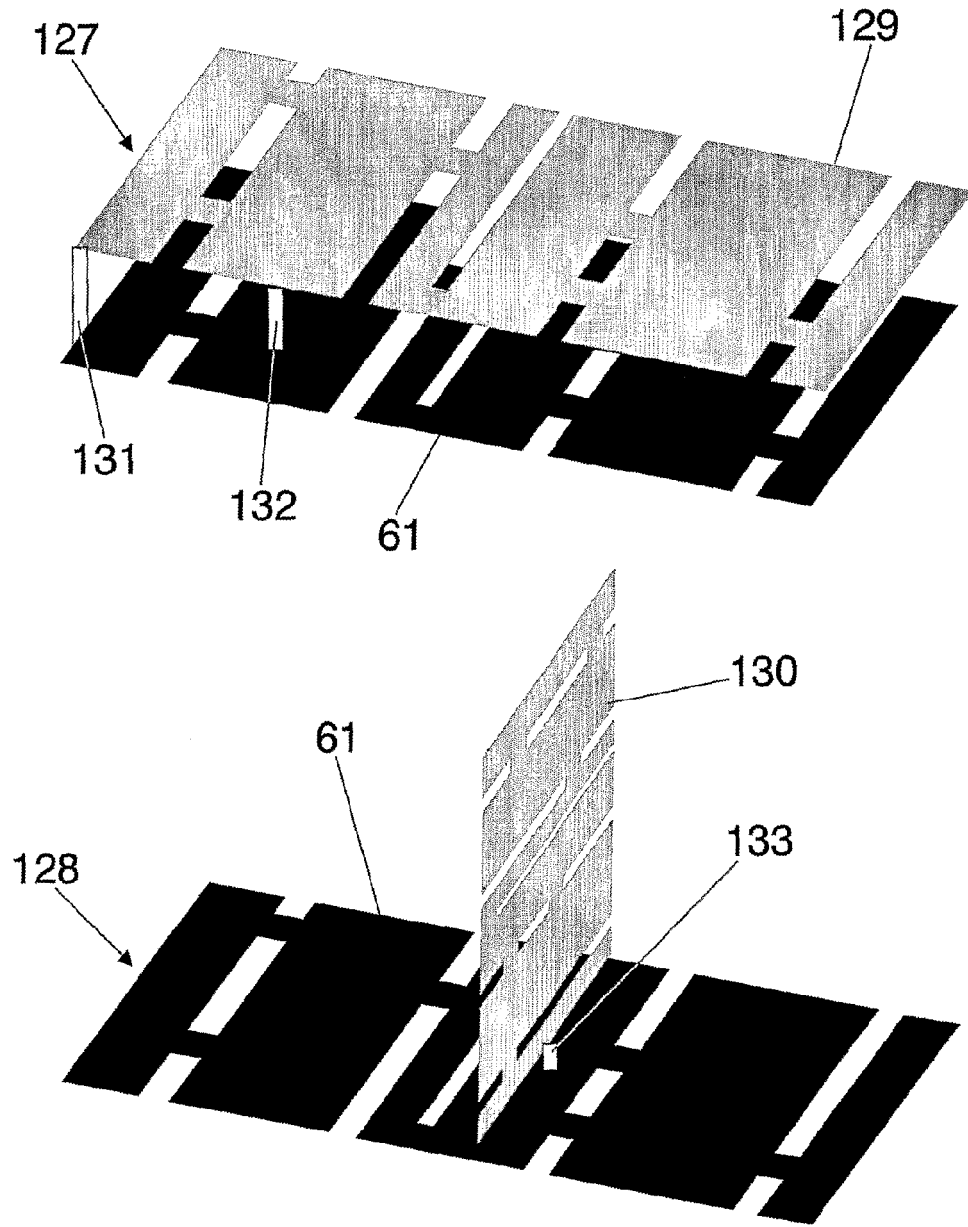

FIG.19

REFERENCES CITED IN THE DESCRIPTION

This list of references cited by the applicant is for the reader's convenience only. It does not form part of the European patent document. Even though great care has been taken in compiling the references, errors or omissions cannot be excluded and the EPO disclaims all liability in this regard.

Patent documents cited in the description

- WO 0122528 A [0001] [0004]
- WO 0154225 A [0001] [0004] [0006]
- US 5703600 A [0005] [0005]
- WO 9627219 A [0008]

Non-patent literature cited in the description

- **D. MANTEUFFEL ; A. BAHR ; I. WOLFF.** Investigation on Integrated Antennas for GSM Mobile Phones. *Millennium Conference on Antennas & Propagation, ESA, AP2000*, April 2000 [0002]
- **T. CHIOU ; K. WONG.** Designs of Compact Microstrip Antennas with a Slotted Ground Plane. *IEEE-APS Symposium*, July 2001, 8-12 [0005]