



US 20060229141A1

(19) **United States**

(12) **Patent Application Publication**
Galloway

(10) **Pub. No.: US 2006/0229141 A1**

(43) **Pub. Date: Oct. 12, 2006**

(54) **HIGH PERFORMANCE LOW COST DRIVER USING MULTIPLE MATERIAL FACE DESIGN**

Publication Classification

(51) **Int. Cl.**
A63B 53/00 (2006.01)

(76) Inventor: **J. Andrew Galloway**, Escondido, CA (US)

(52) **U.S. Cl.** **473/345**

Correspondence Address:
MICHAEL A. CATANIA
CALLAWAY GOLF COMPANY
2180 RUTHERFORD ROAD
CARLSBAD, CA 92008-7328 (US)

(57) **ABSTRACT**

A golf club (40) having a club head (42) with a face cup assembly (59) and an aft-body (61). The face cup assembly (59) includes a face component (60) with a striking plate (58) and a reinforcing plate (57) mounted thereto. The aft-body (61), which is composed of a non-metal material, such as a composite material or a thermoplastic material, includes a crown portion (62), a sole portion (64) and an optional ribbon section (90). The face component (60) and the reinforcing plate (57) are composed of metal materials, while the striking plate (58) is preferably composed of a composite or thermoplastic material.

(21) Appl. No.: **11/398,783**

(22) Filed: **Apr. 5, 2006**

Related U.S. Application Data

(60) Provisional application No. 60/594,449, filed on Apr. 8, 2005.

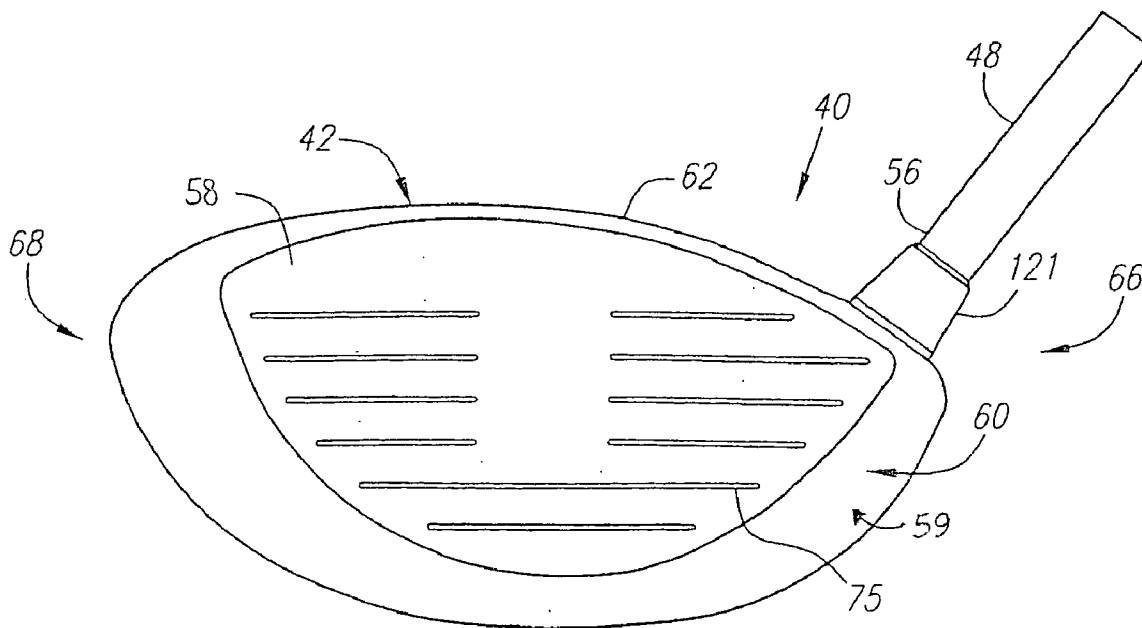

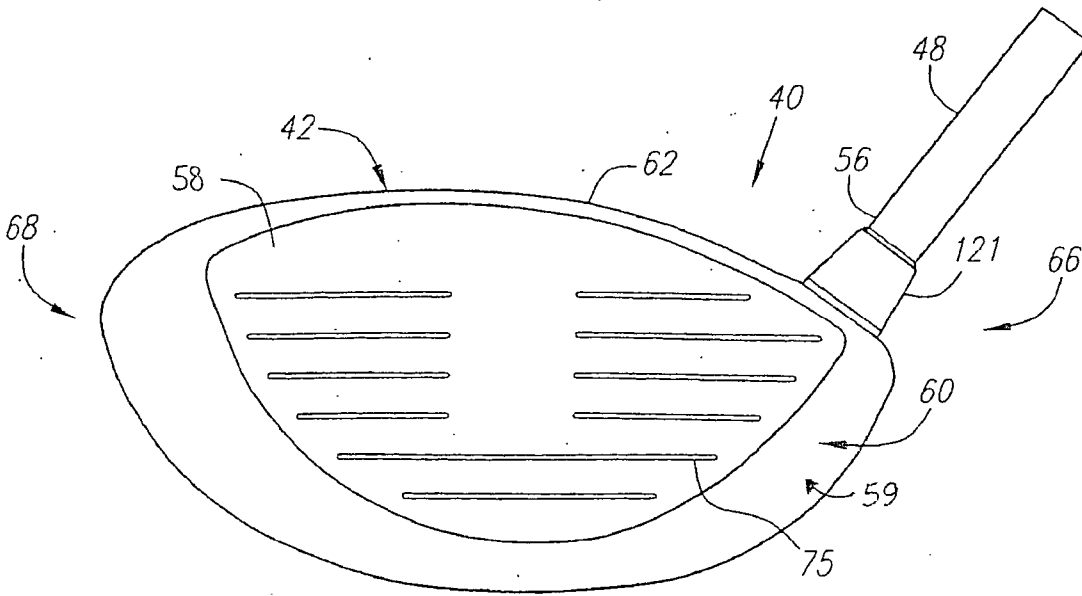

FIG. 1

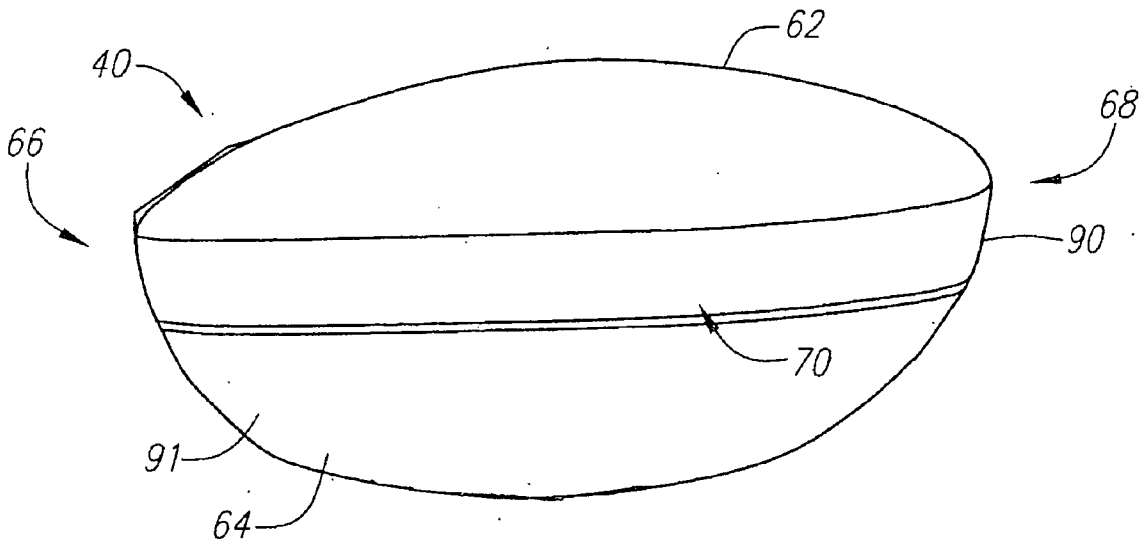

FIG. 2

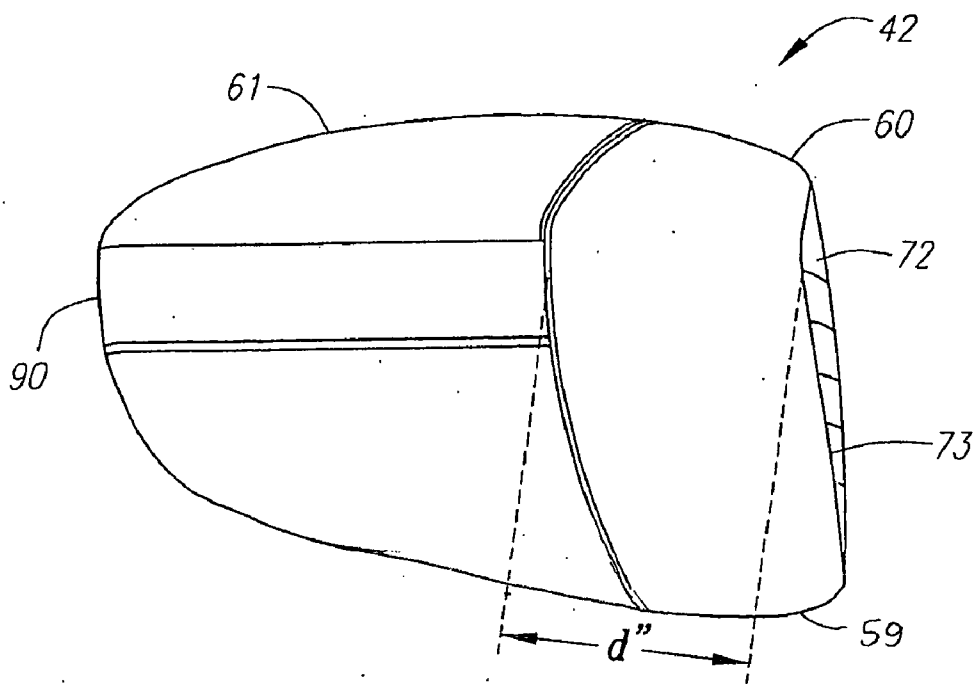

FIG. 3

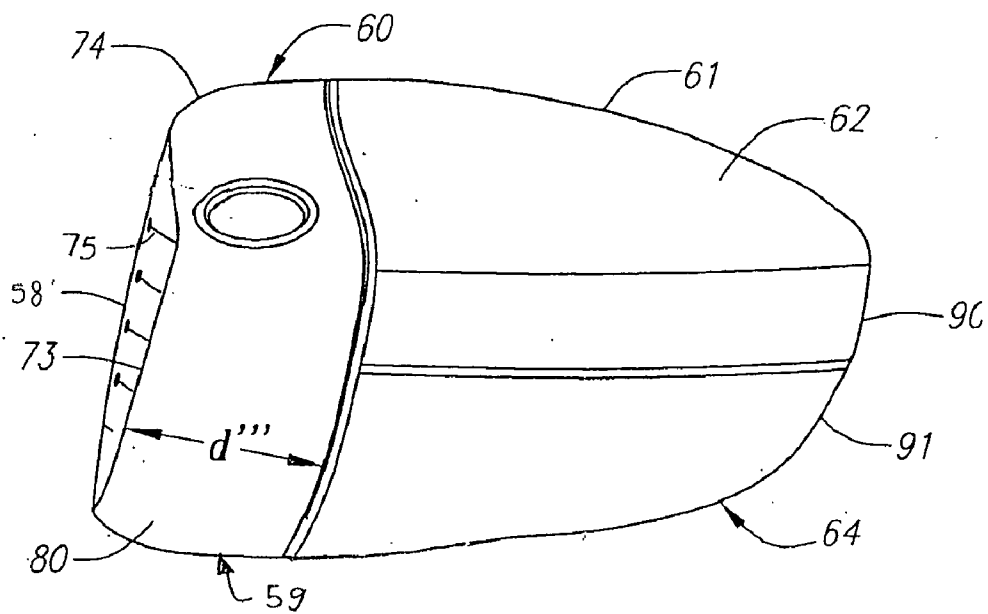

FIG. 4

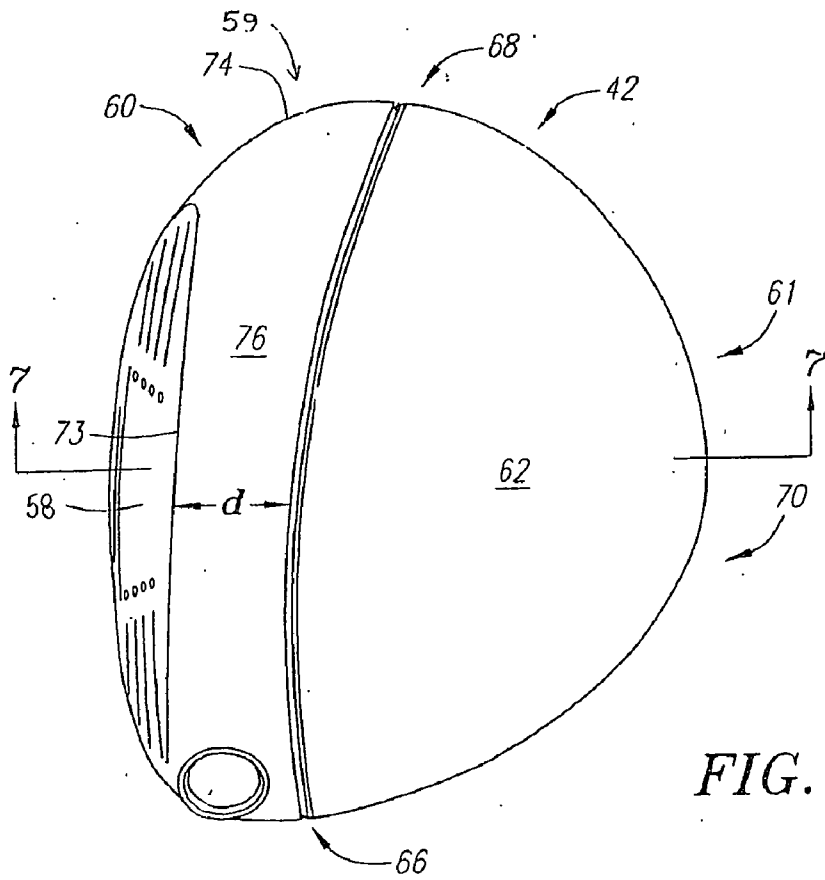

FIG. 5

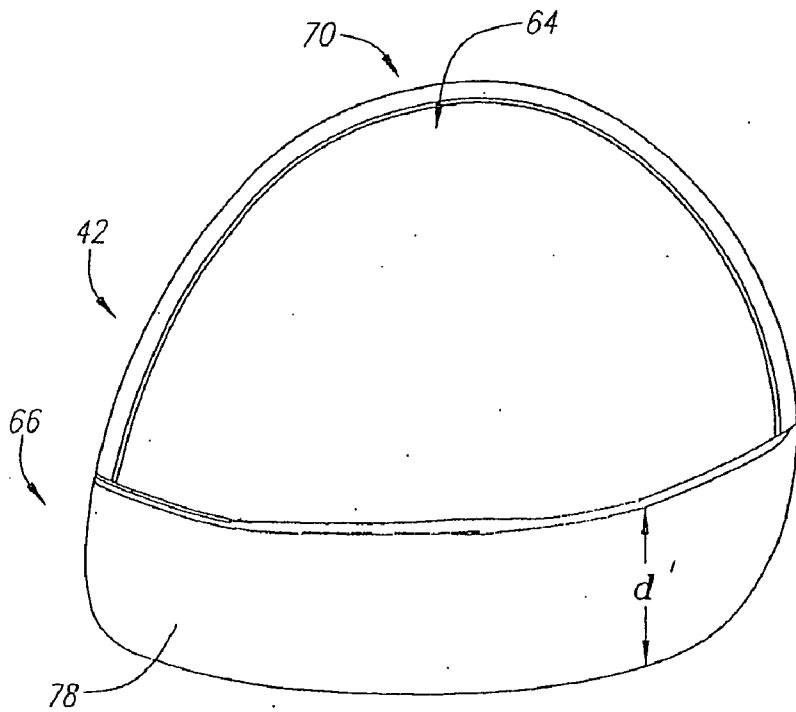

FIG. 6

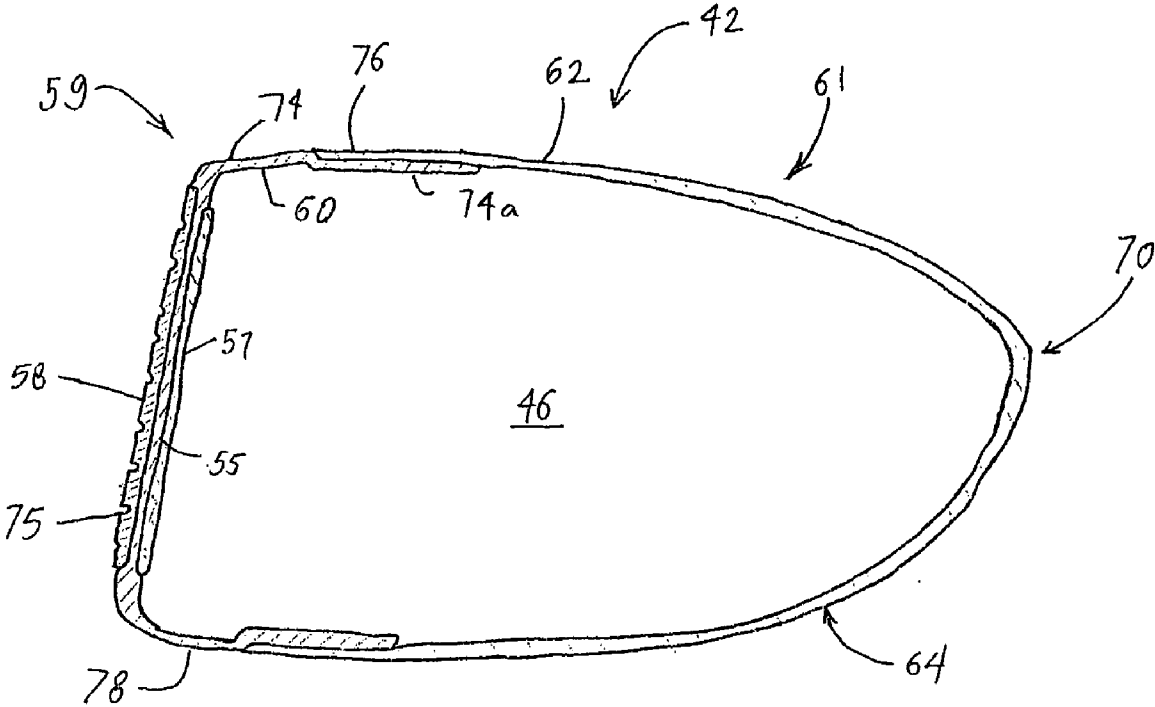

FIG. 7

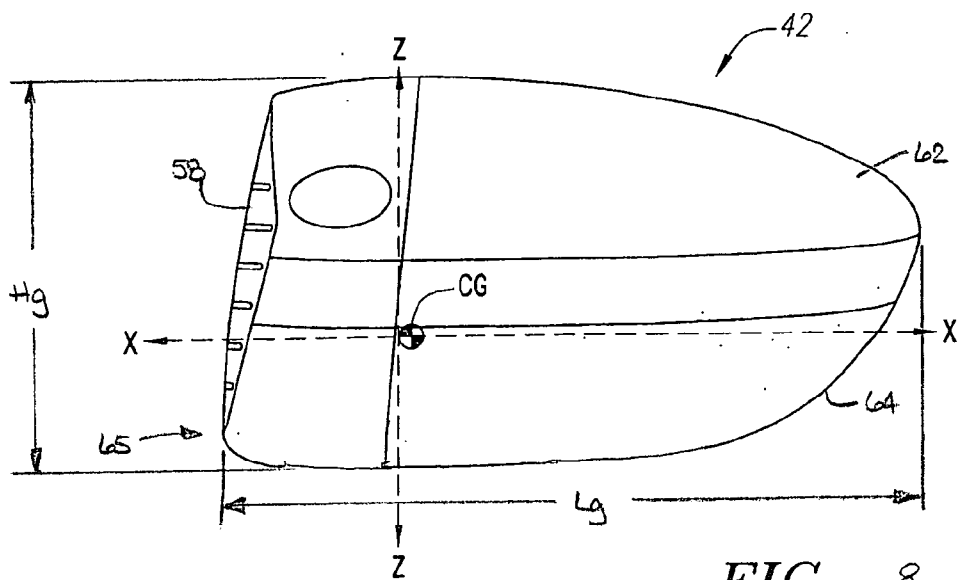

FIG. 8

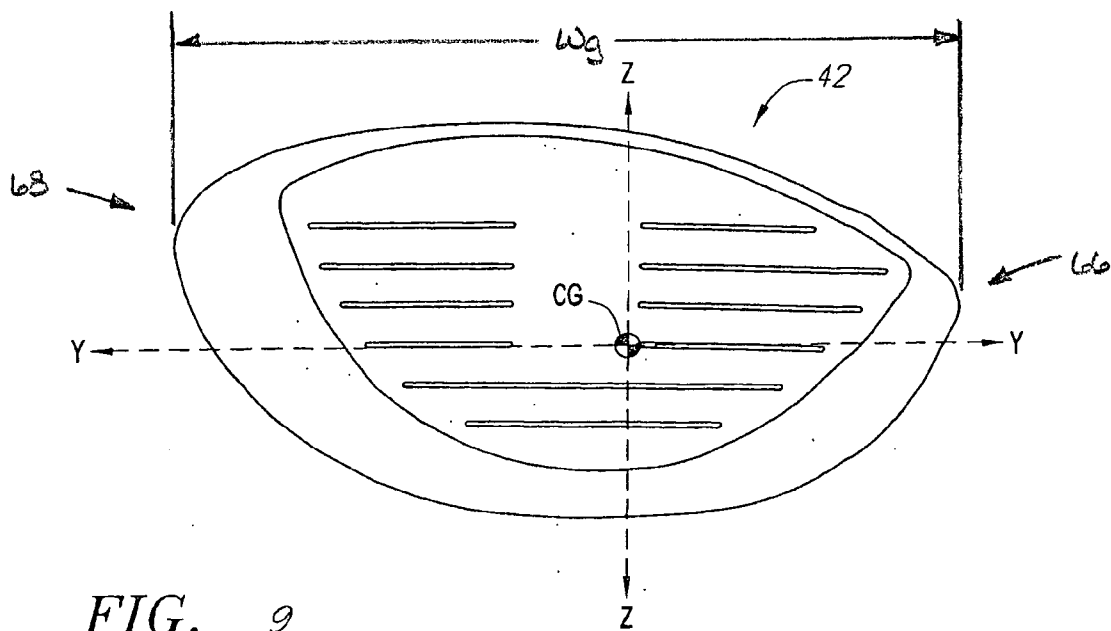

FIG. 9

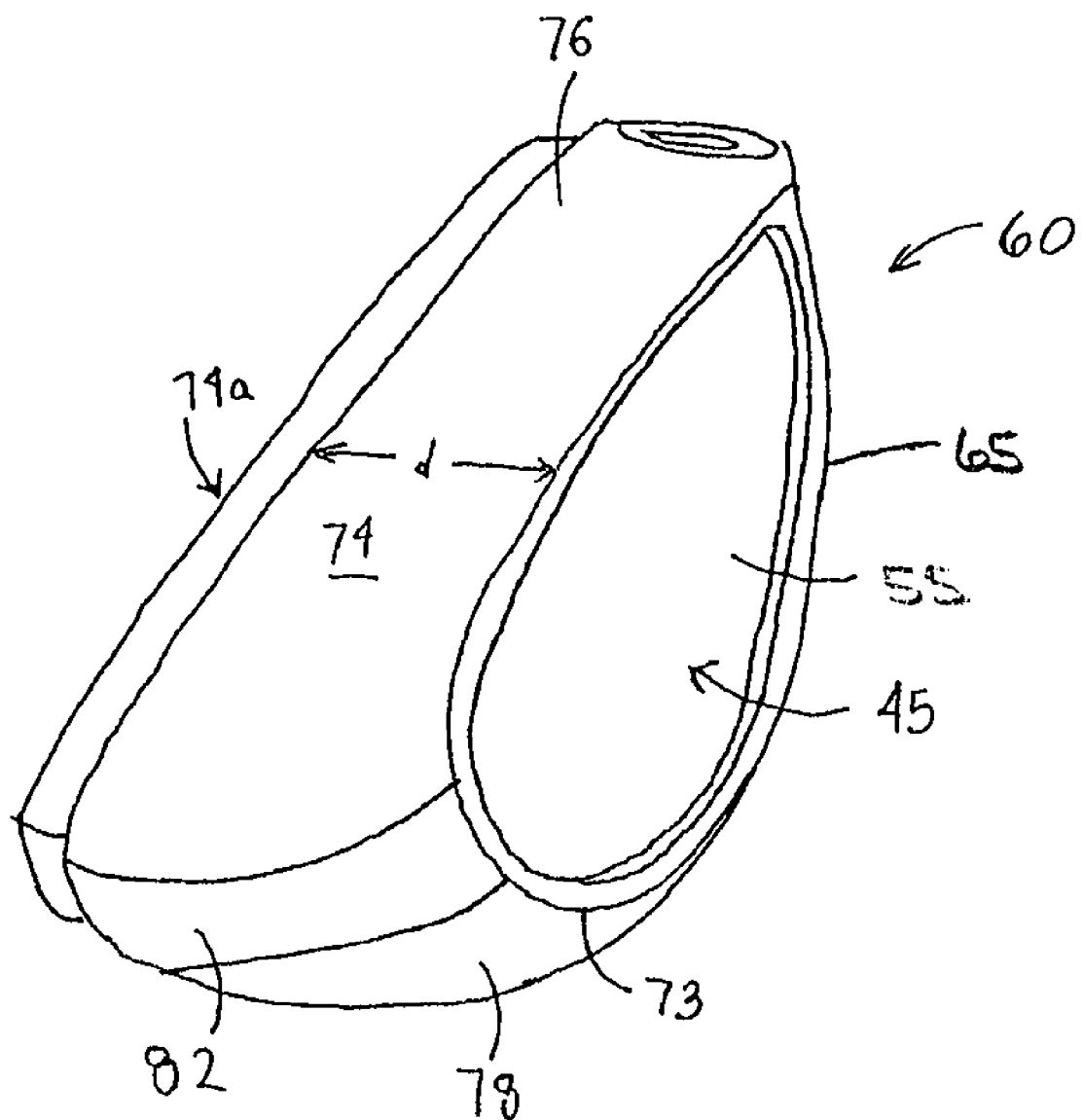

FIG. 10

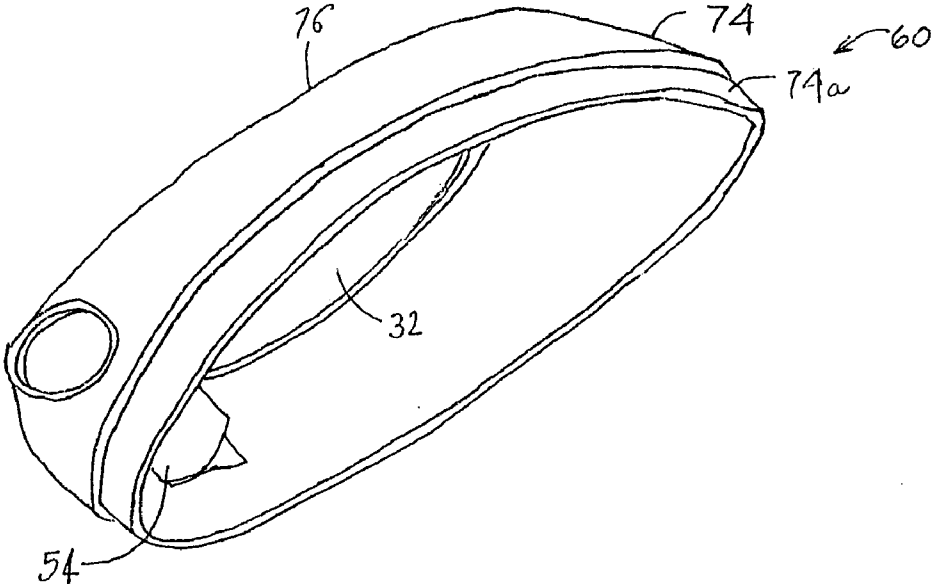

FIG. 11

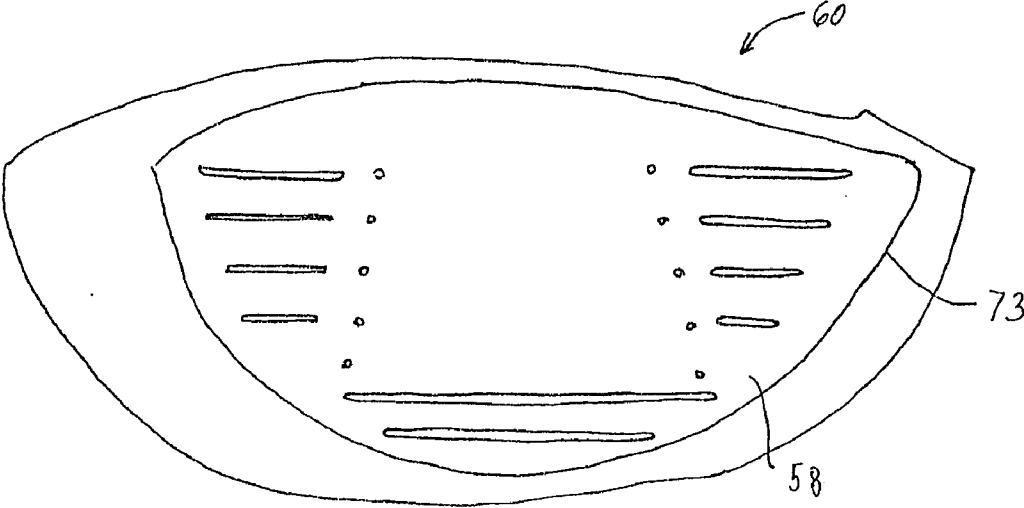

FIG. 12

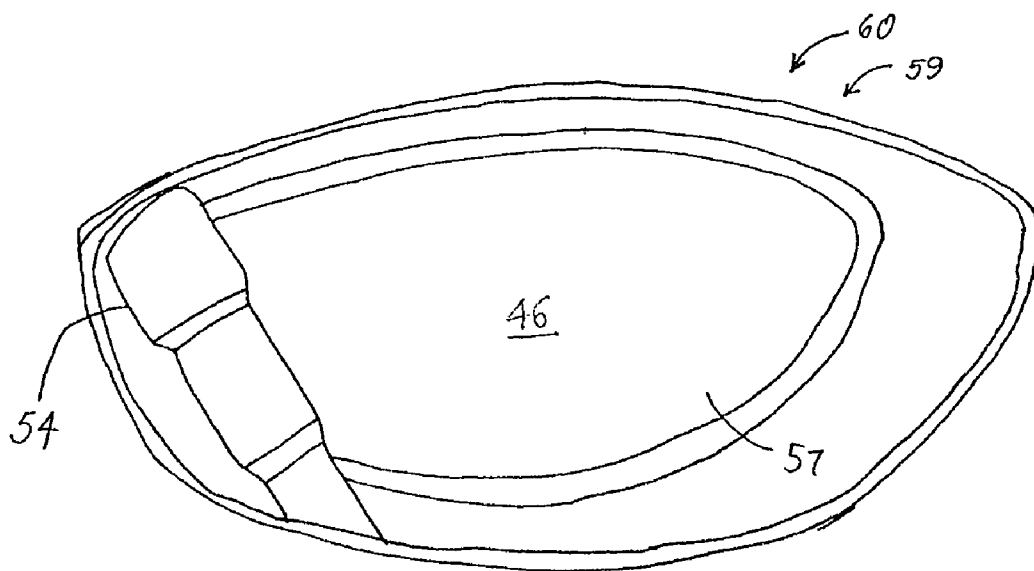

FIG. 13A

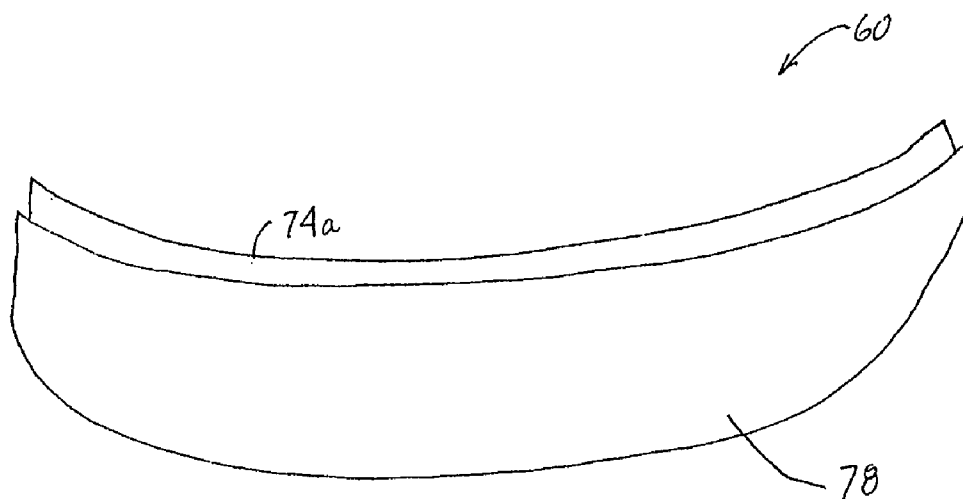

FIG. 13B

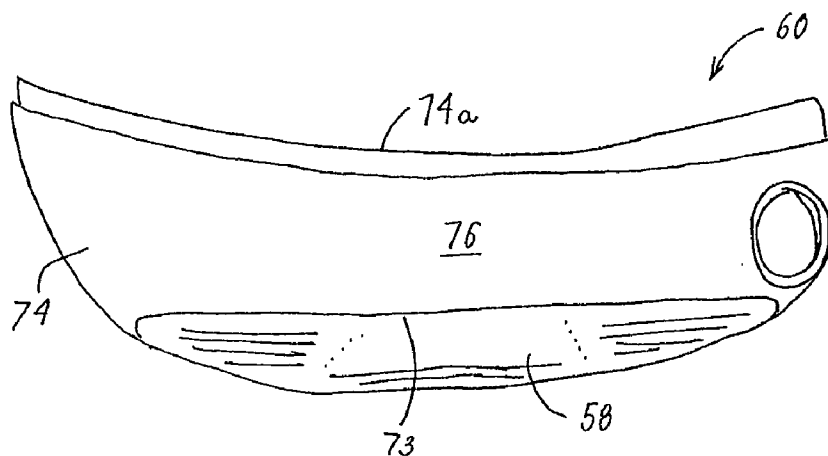

FIG. 13C

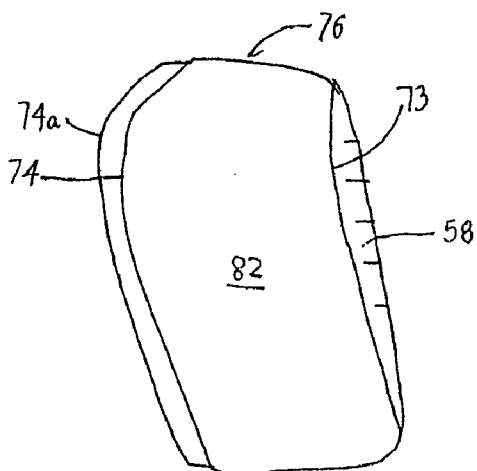

FIG. 13D

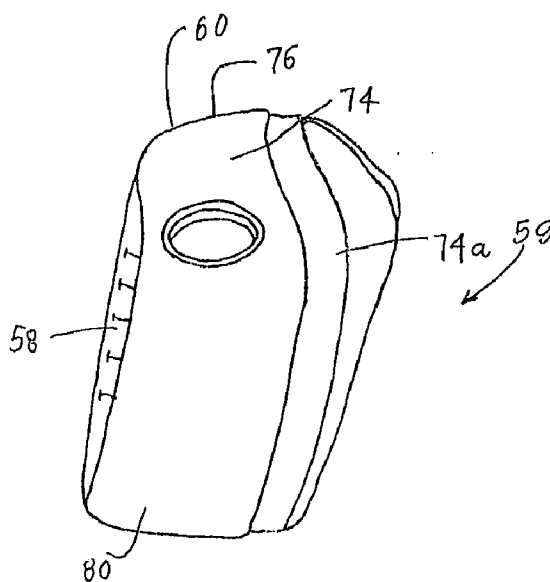

FIG. 13E

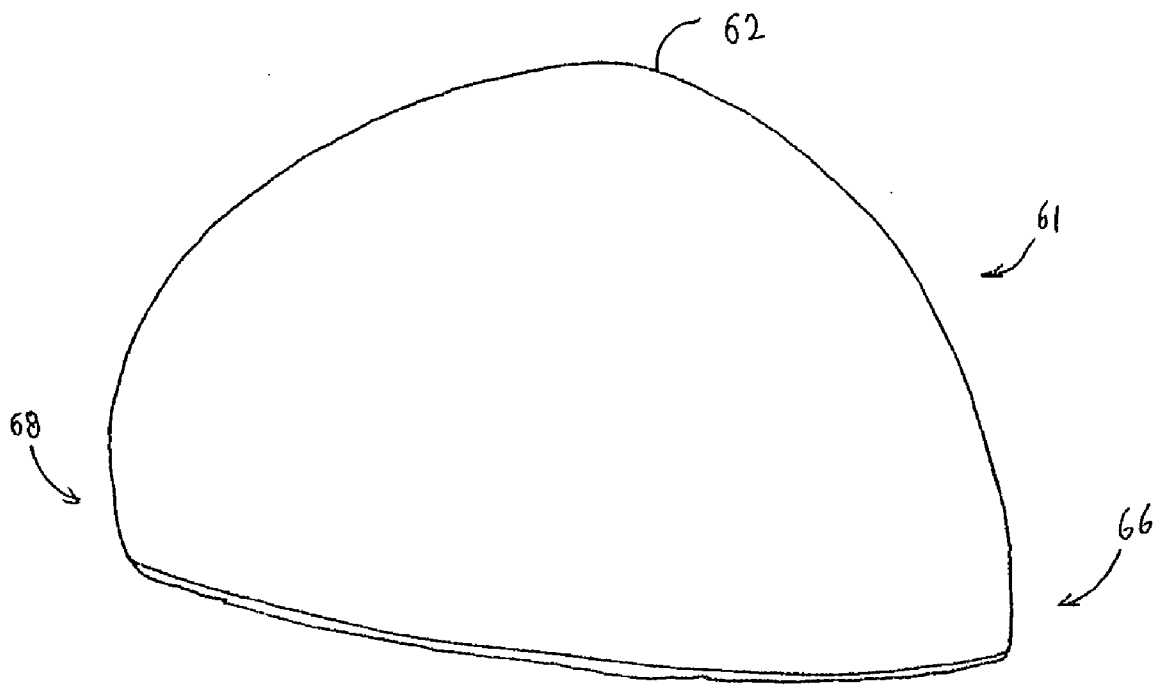

FIG. 14

**HIGH PERFORMANCE LOW COST DRIVER
USING MULTIPLE MATERIAL FACE DESIGN****CROSS REFERENCES TO RELATED
APPLICATIONS**

[0001] This application claims priority to U.S. Patent Application No. 60/594,449, filed on Apr. 8, 2005.

**STATEMENT REGARDING FEDERALLY
SPONSORED RESEARCH OR DEVELOPMENT**

[0002] Not Applicable

BACKGROUND OF THE INVENTION

[0003] 1. Field of the Invention

[0004] The present invention relates to a golf club, particularly to a golf club face which has a striking plate composed of a plurality of materials. More specifically, the present invention relates to a golf club head composed of three materials for a high performance face at a lower production cost.

[0005] 2. Description of the Related Art

[0006] When a golf club head strikes a golf ball, large impacts are produced that load the club head face and the golf ball. Most of the energy is transferred from the head to the golf ball, however, some energy is lost as a result of the collision. The golf ball is typically composed of polymer cover materials (such as ionomers) surrounding a rubber-like core. These softer polymer materials having damping (loss) properties that are strain and strain rate dependent which are on the order of 10-100 times larger than the damping properties of a metallic club face. Thus, during impact most of the energy is lost as a result of the high stresses and deformations of the golf ball (0.001 to 0.20 inch), as opposed to the small deformations of the metallic club face (0.025 to 0.050 inch). A more efficient energy transfer from the club head to the golf ball could lead to greater flight distances of the golf ball.

[0007] The generally accepted approach has been to increase the stiffness of the club head face to reduce metal or club head deformations. However, this leads to greater deformations in the golf ball, and thus increases in the energy transfer problem.

[0008] Some have recognized the problem and disclosed possible solutions. An example is Campau, U.S. Pat. No. 4,398,965, for a Method Of Making Iron Golf Clubs With Flexible Impact Surface, which discloses a club having a flexible and resilient face plate with a slot to allow for the flexing of the face plate. The face plate of Campau is composed of a ferrous material, such as stainless steel, and has a thickness in the range of 0.1 inches to 0.125 inches.

[0009] Another example is Eggiman, U.S. Pat. No. 5,863,261, for a Golf Club Head With Elastically Deforming Face And Back Plates, which discloses the use of a plurality of plates that act in concert to create a spring-like effect on a golf ball during impact. A fluid is disposed between at least two of the plates to act as a viscous coupler.

[0010] Yet another example is Jepson et al, U.S. Pat. No. 3,937,474, for a Golf Club With A Polyurethane Insert. Jepson discloses that the polyurethane insert has a hardness between 40 and 75 shore D.

[0011] Still another example is Inamori, U.S. Pat. No. 3,975,023, for a Golf Club Head With Ceramic Face Plate, which discloses using a face plate composed of a ceramic material having a high energy transfer coefficient, although ceramics are usually harder materials. Chen et al., U.S. Pat. No. 5,743,813 for a Golf Club Head, discloses using multiple layers in the face to absorb the shock of the golf ball. One of the materials is a non-metal material.

[0012] Lu, U.S. Pat. No. 5,499,814, for a Hollow Club Head With Deflecting Insert Face Plate, discloses a reinforcing element composed of a plastic or aluminum alloy that allows for minor deflecting of the face plate which has a thickness ranging from 0.01 to 0.30 inches for a variety of materials including stainless steel, titanium, KEVLAR-RTM., and the like. Yet another Campau invention, U.S. Pat. No. 3,989,248, for a Golf Club Having Insert Capable Of Elastic Flexing, discloses a wood club composed of wood with a metal insert.

[0013] Although not intended for flexing of the face plate, Viste, U.S. Pat. No. 5,282,624 discloses a golf club head having a face plate composed of a forged stainless steel material and having a thickness of 3 mm. Anderson, U.S. Pat. No. 5,344,140, for a Golf Club Head And Method Of Forming Same, also discloses use of a forged material for the face plate. The face plate of Anderson may be composed of several forged materials including steel, copper and titanium. The forged plate has a uniform thickness of between 0.090 and 0.130 inches.

[0014] Another invention directed toward forged materials in a club head is Su et al., U.S. Pat. No. 5,776,011 for a Golf Club Head. Su discloses a club head composed of three pieces with each piece composed of a forged material. The main objective of Su is to produce a club head with greater loft angle accuracy and reduce structural weaknesses. Aizawa, U.S. Pat. No. 5,346,216 for a Golf Club Head, discloses a face plate having a curved ball hitting surface.

[0015] U.S. Pat. No. 6,146,571 to Vincent, et al., discloses a method of manufacturing a golf club head wherein the walls are obtained by injecting a material such as plastic over an insert affixed to a meltable core. The core has a melt point lower than that of the injectable plastic material so that once the core is removed, an inner volume is maintained to form the inner cavity. The insert may comprise a resistance element for reinforcing the internal portion of the front wall of the shell upon removal of the core where the reinforcement element is comprised of aluminum with a laterally extending portion comprised of steel.

[0016] U.S. Pat. No. 6,149,534 to Peters, et al., discloses a golf club head having upper and lower metal engagement surfaces formed along a single plane interface wherein the metal of the lower surface is heavier and more dense than the metal of the upper surface.

[0017] U.S. Pat. Nos. 5,570,886 and 5,547,427 to Rigal, et al., disclose a golf club head of molded thermoplastic having a striking face defined by an impact-resistant metallic sealing element. The sealing element defines a front wall of the striking surface of the club head and extends upward and along the side of the impact surface to form a neck for attachment of the shaft to the club head. The sealing element preferably being between 2.5 and 5 mm in thickness.

[0018] U.S. Pat. No. 5,425,538 to Vincent, et al., discloses a hollow golf club head having steel shell and a composite striking surface composed of a number of stacked woven webs of fiber.

[0019] U.S. Pat. No. 5,377,986 to Viollaz, et al., discloses a golf club head having a body composed of a series of metal plates and a hitting plate comprised of plastic or composite material wherein the hitting plate is imparted with a forwardly convex shape. Additionally, U.S. Pat. No. 5,310,185 to Viollaz, et al., discloses a hollow golf club head having a body composed of a series of metal plates, a metal support plate being located on the front hitting surface to which a hitting plate comprised of plastic or composite is attached. The metal support plate has a forwardly convex front plate associated with a forwardly convex rear plate of the hitting plate thereby forming a forwardly convex hitting surface.

[0020] U.S. Pat. No. 5,106,094 to Desboilles, et al., discloses a golf club head having a metal striking face plate wherein the striking face plate is a separate unit attached to the golf club head with a quantity of filler material in the interior portion of the club head.

[0021] U.S. Pat. No. 4,568,088 to Kurahashi discloses a wooden golf club head body reinforced by a mixture of wood-plastic composite material. The wood-plastic composite material being unevenly distributed such that a higher density in the range of between 5 and 15 mm lies adjacent to and extends substantially parallel with the front face of the club head.

[0022] U.S. Pat. No. 4,021,047 to Mader discloses a golf club wherein the sole plate, face plate, heel, toe and hosel portions are formed as a unitary cast metal piece and wherein a wood or composite crown is attached to this unitary piece thereby forming hollow chamber in the club head.

[0023] U.S. Pat. No. 5,624,331 to Lo, et al. discloses a hollow metal golf club head where the metal casing of the head is composed of at least two openings. The head also contains a composite material disposed within the head where a portion of the composite material is located in the openings of the golf club head casing.

[0024] U.S. Pat. No. 1,167,387 to Daniel discloses a hollow golf club head wherein the shell body is comprised of metal such as aluminum alloy and the face plate is comprised of a hard wood such as beech, persimmon or the like. The face plate is aligned such that the wood grain presents endwise at the striking plate.

[0025] U.S. Pat. No. 3,692,306 to Glover discloses a golf club head having a bracket with sole and striking plates formed integrally thereon. At least one of the plates has an embedded elongate tube for securing a removably adjustable weight means.

[0026] U.S. Pat. No. 5,410,798 to Lo discloses a method of manufacturing a composite golf club head using a metal casing to which a laminated member is inserted. A sheet of composite material is subsequently layered over the openings of the laminated member and metal casing to close off the openings in the top of both. An expansible pocket is then inserted into the hollow laminated member comprising sodium nitrite, ammonium chloride and water causing the

member to attach integrally to the metal casing when the head is placed into a mold and heated.

[0027] U.S. Pat. No. 4,877,249 to Thompson discloses a wood golf club head embodying a laminated upper surface and metallic sole surface having a keel. In order to reinforce the laminations and to keep the body from delaminating upon impact with an unusually hard object, a bolt is inserted through the crown of the club head where it is connected to the sole plate at the keel and tightened to compress the laminations.

[0028] U.S. Pat. No. 3,897,066 to Belmont discloses a wooden golf club head having removably inserted weight adjustment members. The members are parallel to a central vertical axis running from the face section to the rear section of the club head and perpendicular to the crown to toe axis. The weight adjustment members may be held in place by the use of capsules filled with polyurethane resin, which can also be used to form the faceplate. The capsules have openings on a rear surface of the club head with covers to provide access to adjust the weight means.

[0029] U.S. Pat. No. 2,750,194 to Clark discloses a wooden golf club head with weight adjustment means. The golf club head includes a tray member with sides and bottom for holding the weight adjustment preferably cast or formed integrally with the heel plate. The heel plate with attached weight member is inserted into the head of the golf club via an opening.

[0030] U.S. Pat. No. 5,193,811 to Okumoto, et al. discloses a wood type club head body comprised primarily of a synthetic resin and a metallic sole plate. The metallic sole plate has on its surface for bonding with the head body integrally formed members comprising a hosel on the heel side, weights on the toe and rear sides and a beam connecting the weights and hosel. Additionally, U.S. Pat. No. 5,516,107 to Okumoto, et al., discloses a golf club head having an outer shell, preferably comprised of synthetic resin, and metal weight member/s located on the interior of the club head. A foamable material is injected into the hollow interior of the club to form the core. Once the foamable material has been injected and the sole plate is attached, the club head is heated to cause the foamable material to expand thus holding the weight member/s in position in recess/es located in toe, heel and/or back side regions by pushing the weight member into the inner surface of the outer shell.

[0031] U.S. Pat. No. 4,872,685 to Sun discloses a wood type golf club head wherein a female unit is mated with a male unit to form a unitary golf club head. The female unit comprises the upper portion of the golf club head and is preferably composed of plastic, alloy, or wood. The male unit includes the structural portions of sole plate, a face insert consists of the striking plate and weighting elements. The male unit has a substantially greater weight being preferably composed of a light metal alloy. The units are mated or held together by bonding and/or mechanical means.

[0032] U.S. Pat. No. 5,398,935 to Katayama discloses a wood golf club head having a striking face wherein the height of the striking face at a toe end of the golf club head is nearly equal to or greater than the height of the striking face at the center of the club head.

[0033] U.S. Pat. No. 1,780,625 to Mattern discloses a club head with a rear portion composed of a light-weight metal

such as magnesium. U.S. Pat. No. 1,638,916 to Butchart discloses a golf club with a balancing member composed of persimmon or a similar wood material, and a shell-like body composed of aluminum attached to the balancing member.

[0034] The Rules of Golf, established and interpreted by the United States Golf Association (USGA) and The Royal and Ancient Golf Club of Saint Andrews, set forth certain requirements for a golf club head. The requirements for a golf club head are found in Rule 4 and Appendix II. Complete descriptions of the Rules of Golf are available on the USGA web page at www.usga.org. Although the Rules of Golf do not expressly state specific parameters for a golf club face, Rule 4-1e prohibits the face from having the effect at impact of a spring with a golf ball. In 1998, the USGA adopted a test procedure pursuant to Rule 4-1e which measures club face COR. This USGA test procedure, as well as procedures like it, may be used to measure club face COR.

[0035] Although the prior art has disclosed many variations of multiple material club heads, the prior art has failed to provide a multiple material club head with a high coefficient of restitution and greater forgiveness for the typical golfer. This invention utilizes multiple materials in the face to improve on the current state of the art. The selection and distribution of materials results in similar or improved performance over high strength steels and titanium, at lower cost.

BRIEF SUMMARY OF THE INVENTION

[0036] The present invention provides a golf club head with a striking plate having a high coefficient of restitution in order to increase the post-impact velocity of a golf ball for a given pre-impact club head velocity. The present invention is able to accomplish this by using a striking place composed of three materials, including a lightweight composite material.

BRIEF DESCRIPTION OF THE SEVERAL VIEWS OF THE DRAWINGS

- [0037] FIG. 1 is a front view of a golf club.
 [0038] FIG. 2 is a rear view of a golf club head.
 [0039] FIG. 3 is toe side view of the golf club head of FIG. 2.
 [0040] FIG. 4 is a heel side plan view of the golf club head of FIG. 2.
 [0041] FIG. 5 is a top plan view of the golf club head of FIG. 2.
 [0042] FIG. 6 is a bottom view of the golf club head of FIG. 2.
 [0043] FIG. 7 is a cross-sectional view taken generally along line 7-7 of FIG. 5.
 [0044] FIG. 8 is a heel side plan view of a golf club of the present invention illustrating the Z-axis and X-axis.
 [0045] FIG. 9 is a front plan view of a golf club of the present invention illustrating the Z-axis and Y-axis.
 [0046] FIG. 10 is an isolated front perspective view of a face component of the golf club head.

[0047] FIG. 11 is an isolated rear perspective view of a face component of the golf club head.

[0048] FIG. 12 is a isolated front plan view of a face cup assembly of the golf club head.

[0049] FIG. 13A is an interior view of the face cup assembly of FIG. 12.

[0050] FIG. 13B is a bottom plan view of the face cup assembly of FIG. 12.

[0051] FIG. 13C is a top plan view of the face cup assembly of FIG. 12.

[0052] FIG. 13D is a toe side view of the face cup assembly of FIG. 12.

[0053] FIG. 13E is a heel side view of the face cup assembly of FIG. 12.

[0054] FIG. 14 is an isolated top plan view of an aft-body of the golf club head.

DETAILED DESCRIPTION OF THE INVENTION

[0055] As shown in FIG. 1, a golf club is generally designated 40. The golf club 40 has a golf club head 42. When designed as a driver, the club head 42 preferably has a volume from 200 cubic centimeters to 600 cubic centimeters, more preferably from 300 cubic centimeters to 500 cubic centimeters, and most preferably from 350 cubic centimeters to 480 cubic centimeters. The volume of the golf club head 42 will also vary between fairway woods (preferably ranging from 3-woods to eleven woods) with smaller volumes than drivers. The golf club head 42 preferably has a mass no more than 225 grams, and most preferably a mass of 180 grams to 215 grams. Engaging the club head 42 is a shaft 48 that has a grip, not shown, at a butt end and is inserted into a hosel 54 (FIG. 13A) at a tip end 56.

[0056] As shown in FIGS. 1-9, the club head 42 is generally composed of a face cup assembly 59 and an aft-body 61. The face cup assembly 59 is composed of a striking plate 58, a face component 60, and a reinforcing plate 57, which are joined together to form the face cup assembly 59, as discussed in greater detail below. The aft-body 61 preferably has a crown portion 62 and a sole portion 64. The golf club head 42 is preferably has a heel end 66 nearest the shaft 48, a toe end 68 opposite the heel end 66, and a rear end 70 opposite the face component 60.

[0057] The striking plate 58, is preferably composed of a plurality of plies of pre-preg, typically six or seven plies (preferably ranging from three plies to twenty plies) such as disclosed in U.S. Pat. No. 6,248,025, entitled Composite Golf Head and Method of Manufacturing, which is hereby incorporated by reference in its entirety. The striking plate 58 preferably has a thickness between 0.02 inch and 0.10 inch, and more preferably between 0.03 inch and 0.06 inch. The striking plate 58 is provided with a plurality of score-lines 75 thereon.

[0058] The reinforcing plate 57 is preferably composed of a high strength material with tensile strengths between 6-10% during impact with ball including steel and titanium alloys. Such titanium materials include pure titanium and titanium alloys such as 6-4 titanium alloy, SP-700 titanium alloy (available from Nippon Steel of Tokyo, Japan), DAT

55G titanium alloy available from Diado Steel of Tokyo, Japan, Ti 10-2-3 Beta-C titanium alloy available from RTI International Metals of Ohio, and the like. Such steel alloys include 4140, 4340, maraging, maraging 300, high carbon spring steels 1085 and 1095 which have been heat treated to 250-280 ksi yield strengths. Other metals for the reinforcing plate 57 include stainless steel and other high strength amorphous metals. The reinforcing plate 57 is preferably composed of a steel alloy and has a thickness between 0.03 inch and 0.06 inch, and more preferably between 0.04 inch and 0.05 inch.

[0059] The face component 60 is preferably composed of a low density material, preferably a metal. Preferably metals include magnesium alloys, aluminum alloys, magnesium or aluminum material. Exemplary magnesium alloys are available from Phillips Plastics Corporation under the brands AZ-91-D (nominal composition of magnesium with aluminum, zinc and manganese), AM-60-B (nominal composition of magnesium with aluminum and manganese) and AM-50-A (nominal composition of magnesium with aluminum and manganese). According to the preferred embodiment, magnesium is injected molded to form the face component 60, with the face striking wall 55 having a thickness between 0.06 inch and 0.09 inch. Alternatively, if casted aluminum is used to form the face component 60, the face striking wall 55 will have a thickness between 0.05 inch and 0.08 inches.

[0060] FIGS. 10-11 illustrate the face component 60 in isolation. The face component 60 generally includes a striking wall portion 65 and a return portion 74 extending laterally inward from the perimeter of the striking wall portion 65. The face component 60 include a striking plate recess 45 formed in the hitting surface of the striking wall portion 65 and a reinforcing plate recess 32 formed in the non-hitting surface of the striking wall portion 65, where the hitting surface is defined as the surface that faces a golf ball during a golf swing.

[0061] In a preferred embodiment, the return portion 74 generally includes an upper lateral section 76, a lower lateral section 78, a heel lateral section 80 and a toe lateral section 82. Thus, the return portion 74 preferably encircles the striking wall portion 65 a full 360 degrees. However, those skilled in the pertinent art will recognize that the return portion 74 may only encompass a partial section of the striking wall portion 65, such as 270 degrees or 180 degrees, and may also be discontinuous. The return portion 74, includes a return undercut portion 74a, which is placed under the crown portion 62 during attachment to the aft-body 61.

[0062] The upper lateral section 76 extends inward, towards the aft-body 61, a predetermined distance, d, to engage the crown portion 62. In a preferred embodiment, the predetermined distance ranges from 0.2 inch to 1.0 inch, more preferably 0.40 inch to 0.75 inch, and most preferably 0.68 inch, as measured from the perimeter 73 of the striking wall portion 65 to the rearward edge of the upper lateral section 76. In a preferred embodiment, the upper lateral section 76 has a general curvature from the heel end 66 to the toe end 68. The upper lateral section 76 has a length from the perimeter 73 of the striking wall portion 65 that is preferably a minimal length near the center of the striking wall portion 65, and increases toward the toe end 68 and the heel end 66.

[0063] The perimeter 73 of the striking wall portion 65 is defined as the transition point where the face component 60 transitions from a plane substantially parallel to the striking wall portion 65 to a plane substantially perpendicular to the striking wall portion 65. Alternatively, one method for determining the transition point is to take a plane parallel to the striking wall portion 65 and a plane perpendicular to the striking wall portion 65, and then take a plane at an angle of forty-five degrees to the parallel plane and the perpendicular plane. Where the forty-five degrees plane contacts the face component 60 is the transition point thereby defining the perimeter 73 of the striking wall portion 65.

[0064] The present invention preferably has the face component 60 engage the crown portion 62 of the aft-body 61 along a substantially horizontal plane. Such an engagement enhances the flexibility of the striking wall portion 65 allowing for a greater coefficient of restitution. The crown portion 62 and the upper lateral section 76 are attached to each other as further explained below.

[0065] The heel lateral section 80 is substantially perpendicular to the striking wall portion 65, and the heel lateral section 80 covers the hosel 54 before engaging an optional ribbon section 90 and a bottom section 91 of the sole portion 64 of the aft-body 61. The heel lateral section 80 extends inward a distance, d", from the perimeter 73 of 0.200 inch to 1.00 inch, more preferably 0.40 inch to 0.75 inch, and most preferably 0.680 inch. The heel lateral section 80 preferably has a general curvature at its edge.

[0066] At the other end of the face component 60 is the toe lateral section 82. The toe lateral section 82 is attached to the sole 64, both the ribbon section 90 and the bottom section 91, as explained in greater detail below. The toe lateral section 82 extends inward a distance, d", from the perimeter 73 of 0.200 inch to 1.00 inch, more preferably 0.40 inch to 0.75 inch, and most preferably 0.680 inch. The toe lateral section 82 preferably has a general curvature at its edge.

[0067] The lower lateral section 78 extends inward, toward the aft-body 61, a distance, d', to engage the sole 64. In a preferred embodiment, the distance d' ranges from 0.2 inch to 1.25 inches, more preferably 0.20 inch to 1.00 inch, and most preferably 0.680 inch, as measured from the perimeter 73 of the striking wall portion 65 to the edge of the lower lateral section 78.

[0068] As shown in FIGS. 12 and 13A-13E, the face cup assembly 59 is formed as the striking plate 58 and reinforcing plate 57 are bonded to the face component 60 using a bonding method such as adhesive or brazing. The striking plate 58 is mounted in the striking plate recess 45 of the striking wall portion 65 of the face component 60. Similarly, the reinforcing plate 57 is mounted in the reinforcing plate recess 32 of the striking wall portion 65 of the face component 60. Adhesives that may be used include thermosetting adhesives in a liquid or a film medium. A preferred adhesive is a two part liquid epoxy sold by 3M of Minneapolis, Minn. under the brand names DP420NS and DP460NS. Alternative adhesives include modified acrylic liquid adhesives such as DP810NS, also sold by 3M.

[0069] As shown in FIG. 14, the aft-body 61 is preferably composed of a low density material, preferably a metal or a polymer material. Preferred metals include magnesium alloys, aluminum alloys, magnesium or aluminum material.

Exemplary magnesium alloys are available from Phillips Plastics Corporation under the brands AZ-91-D (nominal composition of magnesium with aluminum, zinc and manganese), AM-60-B (nominal composition of magnesium with aluminum and manganese) and AM-50-A (nominal composition of magnesium with aluminum and manganese). The aft-body 61 is preferably manufactured through metal-injection-molding, casting, forming, machining, powdered metal forming, electro chemical milling, and the like. Alternatively, the aft-body is composed of a polymer material such as plies of pre-preg material, thermoplastic materials such as polyurethanes, polyesters, polyamides, ionomers, and other similar materials.

[0070] In the preferred embodiment, a weighting member, not shown, is preferably disposed within the hollow interior 46 of the club head 42. The weighting member may be disposed on the interior surface of the ribbon section 90 of the sole portion 64 in order to increase the moment of inertia and control the center of gravity of the golf club head 42. However, those skilled in the pertinent art will recognize that the weighting member, and any additional weighting members may be placed in other locations of the club head 42 in order to influence the center of gravity, moment of inertia, or other inherent properties of the golf club head 42. The weighting member is preferably tungsten loaded film, tungsten doped polymers, or similar weighting mechanisms such as described in U.S. Pat. No. 6,386,990, filed on Dec. 29, 1999, entitled A Composite Golf Club Head With An Integral Weight Strip, and hereby incorporated by reference in its entirety. Those skilled in the pertinent art will recognize that other high density materials may be utilized as an optional weighting member without departing from the scope and spirit of the present invention.

[0071] The face cup assembly 59 is preferably adhered to the aft-body 61 with an adhesive, which is preferably placed on the interior surface of the aft-body 61. The adhesive may also be placed on the undercut portions 74a. Such adhesives include thermosetting adhesives in a liquid or a film medium. A preferred adhesive is a two part liquid epoxy sold by 3M of Minneapolis, Minn. under the brand names DP420NS and DP460NS. Other alternative adhesives include modified acrylic liquid adhesives such as DP810NS, also sold by 3M. Alternatively, foam tapes such as Hysol Synspan may be utilized with the present invention.

[0072] FIG. 7 illustrates the hollow interior 46 of the club head 42. In the preferred embodiment, the hosel 54 is disposed within the hollow interior 46, and is located as a part of the face component 60 (FIG. 13A). The hosel 54 may be composed of a similar material to the face component 60, and is preferably secured to the face component 60 through welding or the like. The hosel 54 may also be formed with the formation of the face component 60. Additionally, the hosel 54 may be composed of a non-similar material that is light weight and secured using bonding or other mechanical securing techniques. The shaft 48 is disposed within a hosel insert 121 that is disposed within the hosel 54. Such a hosel insert 121 and hosel 54 are described in U.S. Pat. No. 6,352,482, entitled Golf Club With Hosel Liner, which pertinent parts are hereby incorporated by reference. Alternatively, to provide greater capability as to the control of the face angle of the golf club head 42, an insert and hosel liner

combination such as disclosed in U.S. Pat. No. 6,475,100 is utilized, and U.S. Pat. No. 6,475,100 is hereby incorporated by reference in its entirety.

[0073] The present invention is directed at a golf club head that has a high coefficient of restitution thereby enabling for greater distance of a golf ball hit with the golf club head of the present invention. The coefficient of restitution (also referred to herein as "COR") is determined by the following equation:

$$e = \frac{v_2 - v_1}{U_1 - U_2}$$

wherein U_1 is the club head velocity prior to impact; U_2 is the golf ball velocity prior to impact which is zero; v_1 is the club head velocity just after separation of the golf ball from the face of the club head; v_2 is the golf ball velocity just after separation of the golf ball from the face of the club head; and e is the coefficient of restitution between the golf ball and the club face.

[0074] The values of e are limited between zero and 1.0 for systems with no energy addition. The coefficient of restitution, e , for a material such as a soft clay or putty would be near zero, while for a perfectly elastic material, where no energy is lost as a result of deformation, the value of e would be 1.0. The present invention provides a club head having a coefficient of restitution ranging from 0.81 to 0.94, as measured under conventional test conditions.

[0075] The coefficient of restitution of the club head 42 under standard USGA test conditions with a given ball preferably ranges from approximately 0.81 to 0.94, preferably ranges from 0.83 to 0.883 and is most preferably 0.87.

[0076] The volume of the club head 42 of the present invention ranges from 290 cubic centimeters to 600 cubic centimeters, and more preferably ranges from 330 cubic centimeters to 510 cubic centimeters, even more preferably 350 cubic centimeters to 465 cubic centimeters, and most preferably 385 cubic centimeters or 415 cubic centimeters.

[0077] The mass of the club head 42 preferably ranges from 165 grams to 225 grams, more preferably ranges from 175 grams to 205 grams, and most preferably from 190 grams to 200 grams. Preferably, the face cup assembly 59 has a mass ranging from 50 grams to 110 grams, more preferably ranging from 65 grams to 95 grams, yet more preferably from 70 grams to 90 grams, and most preferably 78 grams. The aft-body 61 (without weighting) has a mass preferably ranging from 10 grams to 60 grams, more preferably from 15 grams to 50 grams, and most preferably 35 grams to 40 grams. The interior hosel 54 preferably a mass preferably ranging from 3 grams to 20 grams, more preferably from 5 grams to 15 grams, and most preferably 12 grams. Additionally, epoxy, or other like flowable materials, in an amount ranging from 0.5 gram to 5 grams, may be injected into the hollow interior 46 of the golf club head 42 for selective weighting thereof.

[0078] As shown in FIG. 8, the length, "Lg", of the club head 42 from the striking wall portion 65 to the rear section of the crown portion 62 preferably ranges from 3.0 inches to 4.5 inches, and is most preferably 3.5 inches. The height,

“Hg”, of the club head 42, as measured while in striking position, preferably ranges from 2.0 inches to 3.5 inches, and is most preferably 2.50 inches. As shown in FIG. 9, the width, “Wg”, of the club head 42 from the toe end 68 to the heel end 66 preferably ranges from 4.0 inches to 5.0 inches, and more preferably 4.4 inches.

[0079] FIGS. 8 and 9 further illustrate the axes of inertia through the center of gravity of the golf club head. The axes of inertia are designated X, Y and Z. The X-axis extends from the striking plate 58 through the center of gravity, CG, and to the rear of the golf club head 42. The Y-axis extends from the toe end 68 of the golf club head 42 through the center of gravity, CG, and to the heel end 66 of the golf club head 42. The Z-axis extends from the crown portion 62 through the center of gravity, CG, and to the sole portion 64.

[0080] As defined in *Golf Club Design, Fitting, Alteration & Repair*, 4th Edition, by Ralph Maltby, the center of gravity, or center of mass, of the golf club head is a point inside of the club head determined by the vertical intersection of two or more points where the club head balances when suspended. A more thorough explanation of this definition of the center of gravity is provided in *Golf Club Design, Fitting, Alteration & Repair*.

[0081] The center of gravity of a golf club head may be obtained using a center of gravity table having two weight scales thereon, as disclosed in U.S. Pat. No. 6,607,452, entitled High Moment Of Inertia Composite Golf Club, owned by Callaway Golf Company, and hereby incorporated by reference in its entirety. If a shaft is present, it is removed and replaced with a hosel cube that has a multitude of faces normal to the axes of the golf club head. Given the weight of the golf club head, the scales allow one to determine the weight distribution of the golf club head when the golf club head is placed on both scales simultaneously and weighed along a particular direction, the X, Y or Z direction.

[0082] In general, the golf club head 42 has products of inertia such as disclosed in U.S. Pat. No. 6,425,832, and is hereby incorporated by reference in its entirety. Preferably, each of the products of inertia, Ixy, Ixz and Iyz, of the golf club head 42 have an absolute value less than 100 grams-centimeter squared. Alternatively, the golf club head 42 has at least one or two products of inertia, Ixy, Ixz and Iyz, with an absolute value less than 100 grams-centimeter squared.

[0083] From the foregoing it is believed that those skilled in the pertinent art will recognize the meritorious advancement of this invention and will readily understand that while the present invention has been described in association with a preferred embodiment thereof, and other embodiments illustrated in the accompanying drawings, numerous changes, modifications and substitutions of equivalents may be made therein without departing from the spirit and scope of this invention which is intended to be unlimited by the foregoing except as may appear in the following appended claims. Therefore, the embodiments of the invention in which an exclusive property or privilege is claimed are defined in the following appended claims.

We claim as our invention:

1. A golf club head comprising:

a face component composed of a metal material, the face component having a striking wall portion and a return portion, the striking wall portion having a striking plate

recess formed in a hitting surface of the striking wall portion, a face striking wall, and a reinforcing plate recess formed in a non-hitting surface, the face striking wall having a thickness in the range of 0.05 inch to 0.09 inch, the return portion extending a distance ranging between 0.2 inch and 1.0 inch from a perimeter of the striking wall portion;

a striking plate composed of a composite material and having a thickness in the range of 0.02 inch to 0.10 inch, the striking plate being disposed in the striking plate recess of the face component;

a reinforcing plate composed of a metal material and having a thickness in the range of 0.03 inch to 0.06 inch, the reinforcing plate being disposed in the reinforcing plate recess of the face component; and

an aft-body having a crown portion and a sole portion, the aft-body being attached to the return portion of the face component,

wherein the golf club head has a coefficient of restitution between 0.80 to 0.94.

2. The golf club head according to claim 1 wherein the striking plate has a thickness in the range of 0.03 inch to 0.06 inch, and the striking plate comprises a plurality of plies of pre-preg sheets.

3. The golf club head according to claim 1 wherein the face component is composed of magnesium, and the face striking wall has a thickness in the range of 0.06 inch to 0.09 inch.

4. The golf club head according to claim 1 wherein the face component is composed of aluminum, and the face striking wall has a thickness in the range of 0.05 inch to 0.08 inch.

5. The golf club head according to claim 1 wherein the reinforcing plate has a thickness in the range of 0.04 inch to 0.05 inch and is composed of a metal material selected from the group consisting of titanium, stainless steel, titanium alloys, and maraging steel.

6. The golf club head according to claim 1 which has a volume between 290 cubic centimeters and 600 cubic centimeters.

7. The golf club head according to claim 1 wherein a moment of inertia about the Izz axis is greater than 3000 grams-centimeters squared and a moment of inertia about the Iyy axis is greater than 1900 grams-centimeters squared.

8. A golf club head comprising:

a face component composed of a first metal material, the face component having a striking wall portion and a return portion, the striking wall portion having a striking plate recess formed in a hitting surface of the striking wall portion, a face striking wall, and a reinforcing plate recess formed in a non-hitting surface, the face striking wall having a thickness in the range of 0.05 inch to 0.09 inch, the return portion extending a distance ranging between 0.2 inch to 1.0 inch from a perimeter of the striking wall portion;

a striking plate composed of a composite material and having a thickness in the range of 0.03 inch to 0.06 inch, the striking plate being disposed in the striking plate recess of the face component;

a reinforcing plate composed of a second metal material and having a thickness in the range of 0.03 inch to 0.06

inch, the second metal material having a higher density than the first metal material, the reinforcing plate being disposed in the reinforcing plate recess of the face component; and

an aft-body having a crown portion, a sole portion, the aft-body being attached to the return portion of the face component,

wherein the golf club head has a moment of inertia about the I_{zz} axis greater than 3000 grams-centimeters-squared and moment of inertia about the I_{yy} axis greater than 1900 grams-centimeters-squared.

9. The golf club head according to claim 8 wherein the aft-body further comprises a ribbon and a weight strip composed of a metal material disposed in the ribbon.

10. The golf club head according to claim 8 wherein the face component includes an integral hosel.

11. The golf club head according to claim 8 wherein the coefficient of restitution is between 0.80 and 0.94.

12. The golf club head according to claim 8 wherein the striking plate portion has an aspect ratio no greater than 1.7.

13. The golf club head according to claim 8 wherein the golf club head has a volume in the range of 385 cubic centimeters to 415 cubic centimeters, and a weight in the range of 100 grams to 195 grams.

14. The golf club head according to claim 8 wherein the first metal material is selected from the group consisting of magnesium, magnesium alloys, aluminum, and aluminum alloys.

15. The golf club head according to claim 8 wherein the second metal material is selected from the group consisting of titanium, titanium alloys, and steel alloys.

* * * * *