



US00D856528S

(12) **United States Design Patent** (10) **Patent No.:** **US D856,528 S**
Bulloch et al. (45) **Date of Patent:** **** Aug. 13, 2019**

(54) **CASSETTE CLAMP FOR ELECTROPHORESIS GEL CASTING**
(71) Applicant: **LIFE TECHNOLOGIES CORPORATION**, Carlsbad, CA (US)

FOREIGN PATENT DOCUMENTS

WO 1995024640 9/1995
WO 1999054721 10/1999
WO 2007032951 3/2007

(72) Inventors: **Kyle Bulloch**, San Diego, CA (US);
Xin Mathers, Poway, CA (US)

OTHER PUBLICATIONS

(73) Assignee: **LIFE TECHNOLOGIES CORPORATION**, Carlsbad, CA (US)

Caprette, D. "Characterization of red cell membrane proteins by SDS-Page—Preparing SDS Gels," <http://www.ruf.rice.edu/~bioslabs/studies/sds-page/gellab2a.html>, updated May 24, 2005, downloaded Jan. 2, 2017, pp. 1-5.

(**) Term: **15 Years**

Primary Examiner — Ian Simmons
Assistant Examiner — Samantha Q Lawrence

(21) Appl. No.: **29/545,635**

(57) **CLAIM**

(22) Filed: **Nov. 13, 2015**

The ornamental design for a cassette clamp for electrophoresis gel casting, as shown and described.

(51) **LOC (12) Cl.** **24-99**

(52) **U.S. Cl.**
USPC **D24/233**

DESCRIPTION

(58) **Field of Classification Search**
USPC D24/216, 222, 224–227, 231–233;
D10/81
CPC B01D 57/02; B01L 3/0268; B01L 3/0275;
B01L 3/5085; G01N 27/447; G01N
27/44704; G01N 27/44717; G01N
27/44721; G01N 27/44739; G01N
27/44743; G01N 27/44747; G01N
27/44756; G01N 27/44769; G01N
27/44773; G01N 27/44778; G01N
27/44782; G01N 27/44795; G01N
33/559561

This application is related to U.S. Design patent application Ser. No. 29/545,637, entitled "Rig for Electrophoresis Gel Casting," and filed on a date even herewith, the entire contents of each of which are incorporated by reference herein.

FIG. 1 is a front perspective view of a first embodiment of a cassette clamp for electrophoresis gel casting showing our new design.

FIG. 2 is back perspective view thereof.

FIG. 3 is a front view thereof.

FIG. 4 is a back view thereof.

FIG. 5 is a right side view thereof.

FIG. 6 is a left side view thereof.

FIG. 7 is a top view thereof.

FIG. 8 is a bottom view thereof; and,

FIG. 9 is a front perspective view thereof showing environmental structure.

The broken lines in the figures show unclaimed portions and environmental structure and form no part of the claimed design.

See application file for complete search history.

(56) **References Cited**

U.S. PATENT DOCUMENTS

3,888,759 A 6/1975 Elson
4,294,684 A 10/1981 Serwer
D269,123 S * 5/1983 Hoefler D24/233
4,560,459 A 12/1985 Hoefler
(Continued)

1 Claim, 4 Drawing Sheets

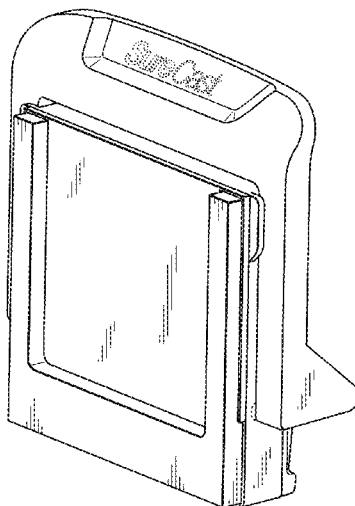

(56)

References Cited

U.S. PATENT DOCUMENTS

4,574,040	A *	3/1986	Delony	G01N 27/44756	6,521,111	B1	2/2003	Amshey	
				204/606	D505,729	S	5/2005	Lee	
4,693,804	A	9/1987	Serwer		6,929,732	B2	8/2005	Chen	
4,715,942	A	12/1987	Tezuka		6,932,895	B2	8/2005	Anderson	
4,772,373	A *	9/1988	Ebata	G01N 27/44756	6,936,150	B2 *	8/2005	Rooney	G01N 27/44704
				204/618					204/456
4,773,984	A *	9/1988	Flesher	G01N 27/44704	6,942,775	B1 *	9/2005	Fox	G01N 27/44704
				204/618					204/456
4,795,541	A	1/1989	Hurd		D510,770	S	10/2005	Emerson	
D303,007	S	8/1989	Flesher et al.		D511,386	S	11/2005	Emerson	
4,957,613	A *	9/1990	Schuette	G01N 27/44704	6,969,455	B1 *	11/2005	Helfer	G01N 27/44704
				204/618					204/618
4,975,174	A *	12/1990	Bambeck	G01N 27/44704	D524,449	S	7/2006	Emerson	
				204/618	7,135,101	B2	11/2006	Atchison et al.	
5,073,246	A	12/1991	Chu		7,276,143	B2 *	10/2007	Chen	G01N 27/44756
5,116,483	A	5/1992	Lander						204/467
5,192,408	A	3/1993	Scott		7,544,279	B2 *	6/2009	Chen	G01N 27/447
5,228,971	A	7/1993	Brumley et al.						204/616
5,238,651	A	8/1993	Chuba		7,601,251	B2	10/2009	Rooney	
5,284,565	A	2/1994	Chu		7,749,367	B2 *	7/2010	Zhou	G01N 27/44704
5,292,420	A *	3/1994	Nakanura	G01N 27/44773					204/467
				204/613	D654,597	S	2/2012	Hiramura	
5,407,552	A	4/1995	Lebacq		8,361,294	B2	1/2013	Wang	
D367,713	S	3/1996	La Motte		8,398,838	B2 *	3/2013	Chen	G01N 27/44773
5,618,399	A	4/1997	Gautsch						204/450
5,626,735	A *	5/1997	Chu	G01N 27/44704	8,449,745	B2 *	5/2013	Wang	G01N 27/44756
				204/606					204/466
5,632,877	A *	5/1997	Van Atta	G01N 27/44704	8,480,874	B2	7/2013	Henry	
				204/467	D719,277	S	12/2014	Miller	
5,685,967	A	11/1997	Manis		D733,922	S	7/2015	Sjolander	
5,753,095	A	5/1998	Alpenfels		9,234,874	B2	1/2016	Panattoni	
5,773,645	A	6/1998	Hochstrasser		D757,958	S	5/2016	Murray et al.	
5,827,418	A	10/1998	Haven		9,383,335	B2	7/2016	Bjorkesten	
5,843,295	A	12/1998	Steiner		9,400,260	B2 *	7/2016	Suh	G01N 27/44773
5,885,431	A	3/1999	Renfrew et al.		D792,603	S *	7/2017	Bulloch	D24/233
5,888,369	A	3/1999	Tippins		9,714,918	B2	7/2017	Updyke	
5,972,188	A	10/1999	Rice		D794,823	S	8/2017	Nelson	
5,989,403	A	11/1999	Provonchee		D795,449	S	8/2017	Miller	
6,001,233	A *	12/1999	Levy	G01N 27/44704	D806,894	S	1/2018	Nelson	
				204/618	1,010,129	A1	10/2018	Strong et al.	
6,027,628	A	2/2000	Yamamura		2002/0079222	A1	6/2002	Sevigny	
6,110,340	A *	8/2000	Lau	G01N 27/44704	2006/0163067	A1	7/2006	Sevigny	
				204/467	2006/0278533	A1	12/2006	Chen	
6,110,344	A	8/2000	Renfrew		2007/0205108	A1	9/2007	Tzu-Chao et al.	
6,139,709	A	10/2000	Scott		2007/0284250	A1	12/2007	Magnant	
D443,068	S	5/2001	Manusu		2011/0042213	A1	2/2011	Updyke	
6,231,741	B1	5/2001	Tuurenhout		2011/0042217	A1	2/2011	Updyke et al.	
6,379,519	B1	4/2002	Sevigny		2014/0045250	A1	2/2014	Kreifels et al.	
6,436,262	B1 *	8/2002	Perez	G01N 27/44704	2016/0041123	A1	2/2016	Guadagno	
				204/466	2016/0084797	A1	3/2016	Goh et al.	
					2016/0258903	A1	9/2016	Ran et al.	
					2017/0153204	A1	6/2017	Bulloch	

* cited by examiner

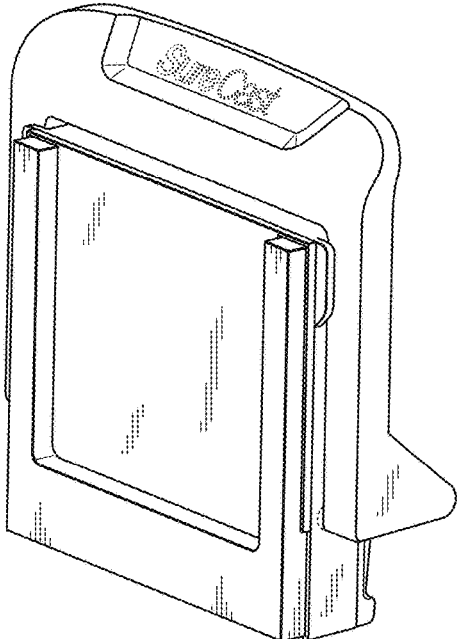

FIG. 1

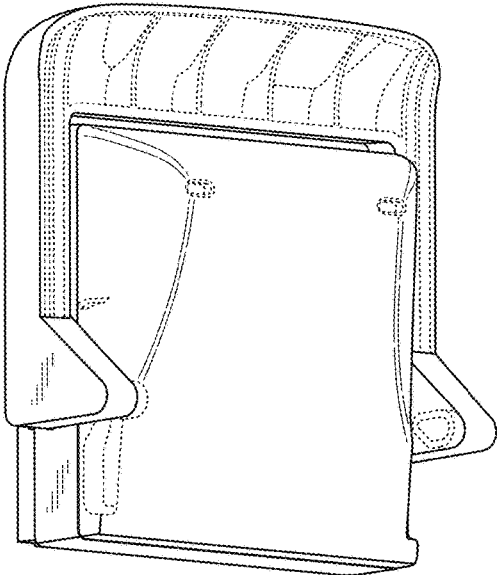

FIG. 2

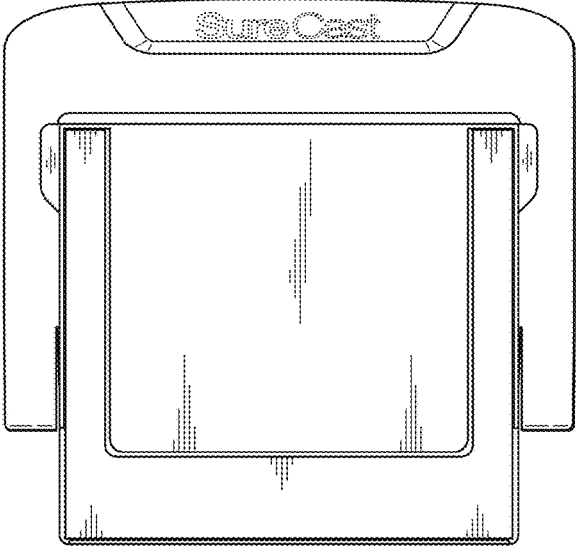

FIG. 3

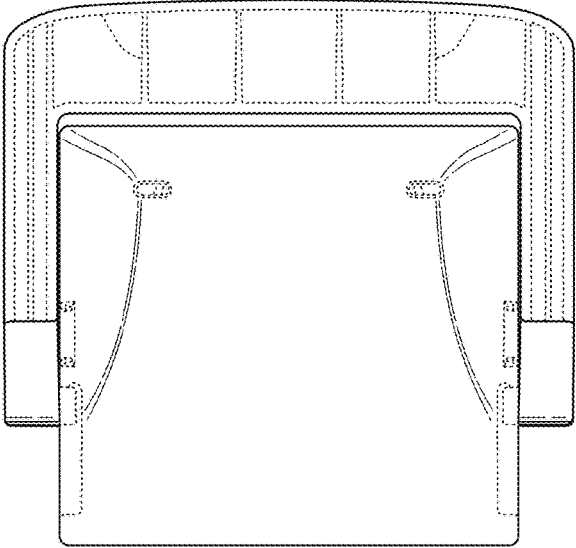

FIG. 4

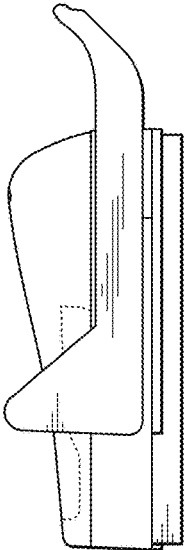

FIG. 5

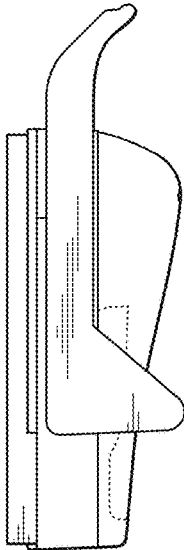

FIG. 6

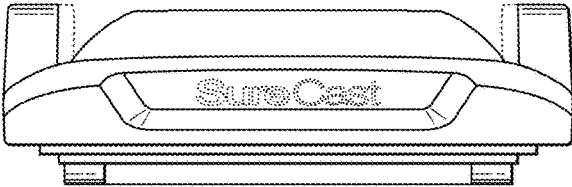

FIG. 7

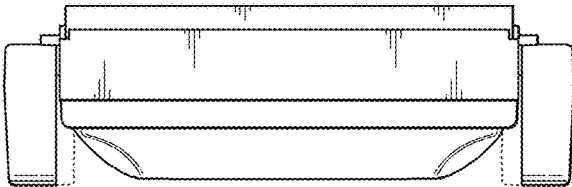

FIG. 8

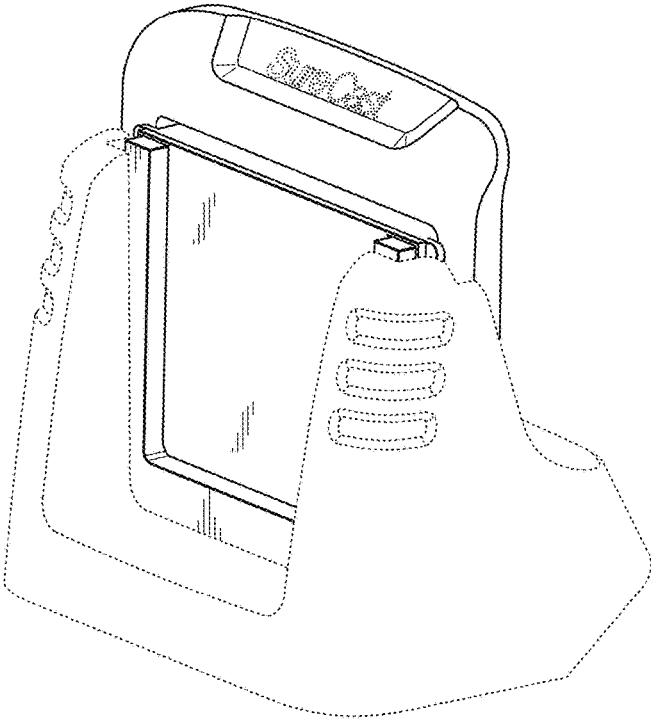

FIG. 9