



US 20050137531A1

(19) **United States**

(12) **Patent Application Publication**
Prausnitz et al.

(10) **Pub. No.: US 2005/0137531 A1**

(43) **Pub. Date: Jun. 23, 2005**

(54) **DEVICES AND METHODS FOR ENHANCED
MICRONEEDLE PENETRATION OF
BIOLOGICAL BARRIERS**

(52) **U.S. Cl. 604/173**

(76) **Inventors: Mark R. Prausnitz, Decatur, GA (US);
Mark G. Allen, Atlanta, GA (US);
Sebastian Henry, Ay (FR); Devin V.
McAllister, Holley, NY (US); Donald
E. Ackley, Cardiff, CA (US); Thomas
Jackson, La Jolla, CA (US)**

(57) **ABSTRACT**

Microneedle devices and methods of use thereof are provided for the enhanced transport of molecules, including drugs and biological molecules, across tissue by improving the interaction of microneedles and a deformable, elastic biological barrier, such as human skin. The devices and methods act to (1) limit the elasticity, (2) adapt to the elasticity, (3) utilize alternate ways of creating the holes for the microneedles to penetrate the biological barrier, other than the simply direct pressure of the microneedle substrate to the barrier surface, or (4) any combination of these methods. In preferred embodiments for limiting the elasticity of skin, the microneedle device includes features suitable for stretching, pulling, or pinching the skin to present a more rigid, less deformable, surface in the area to which the microneedles are applied (i.e. penetrate). In a preferred embodiment for adapting the device to the elasticity of skin, the device comprising one or more extensions interposed between the substrate and the base end of at least a portion of the microneedles.

Correspondence Address:
**FISH & NEAVE IP GROUP
ROPES & GRAY LLP
ONE INTERNATIONAL PLACE
BOSTON, MA 02110-2624 (US)**

(21) **Appl. No.: 10/856,691**

(22) **Filed: May 28, 2004**

Related U.S. Application Data

(63) **Continuation of application No. 09/448,107, filed on
Nov. 23, 1999, now Pat. No. 6,743,211.**

Publication Classification

(51) **Int. Cl.⁷ A61M 5/00**

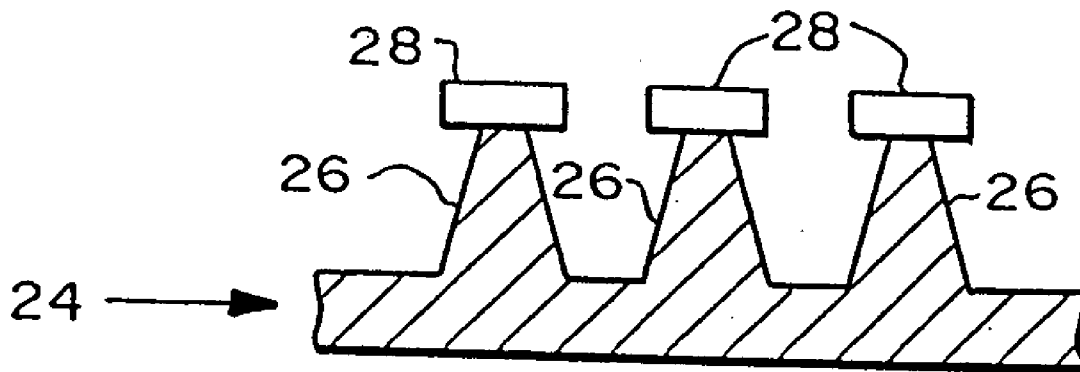

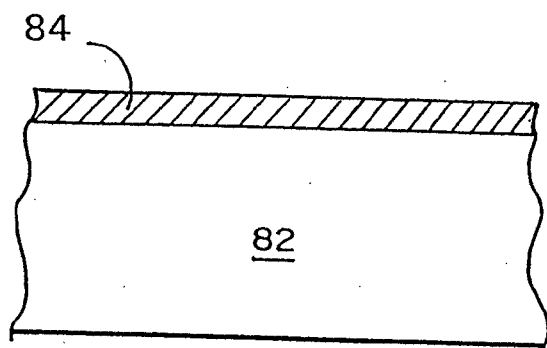

FIG. 1A

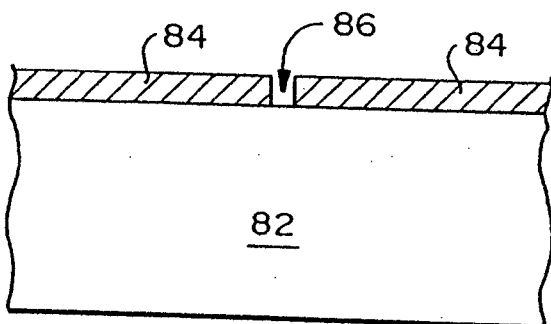

FIG. 1B

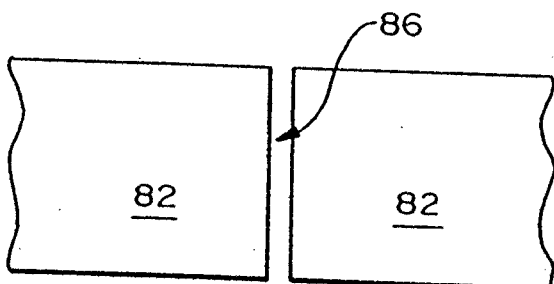

FIG. 1C

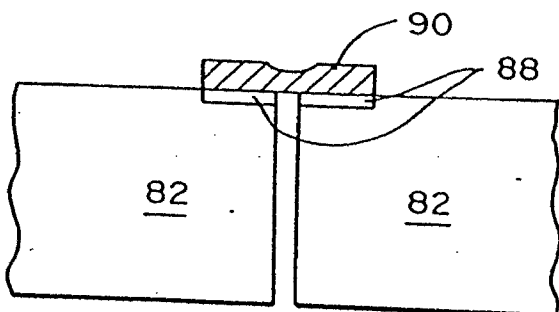

FIG. 1D

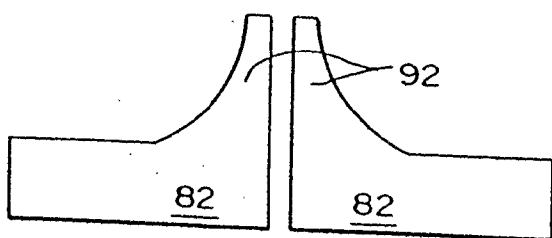

FIG. 1E

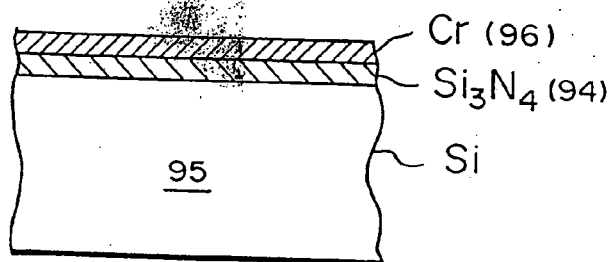

FIG. 2A

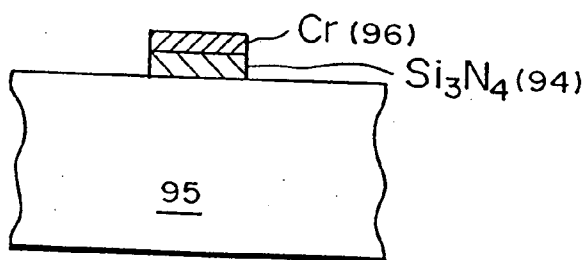

FIG. 2B

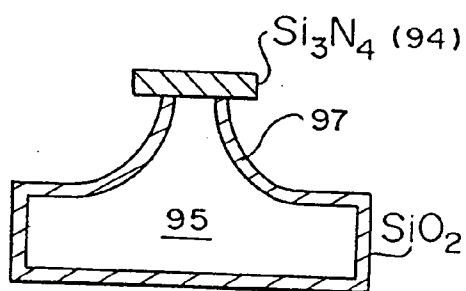

FIG. 2E

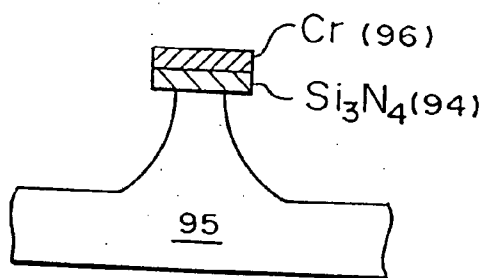

FIG. 2C

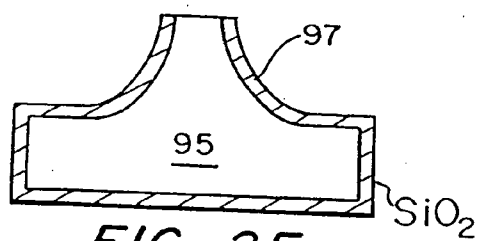

FIG. 2F

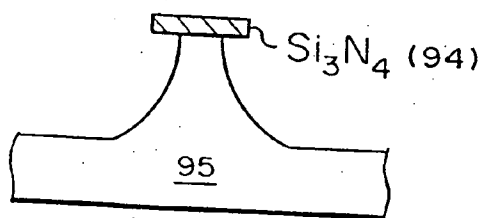

FIG. 2D

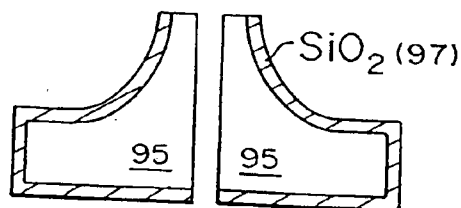

FIG. 2G

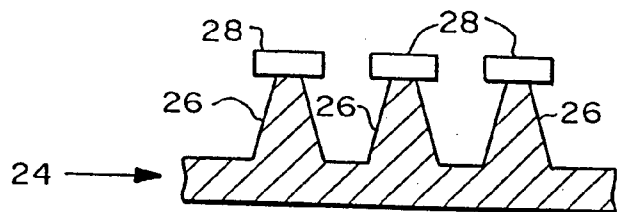

FIG. 3A

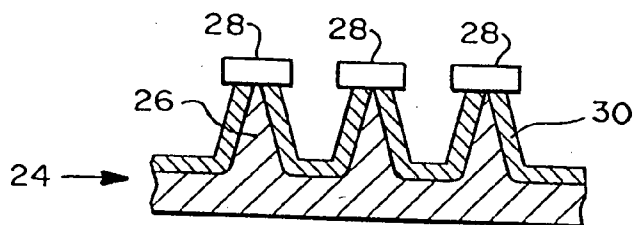

FIG. 3B

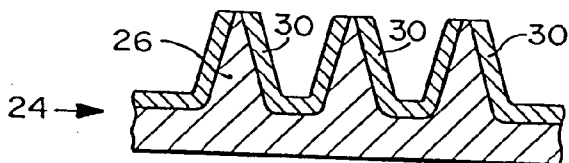

FIG. 3C

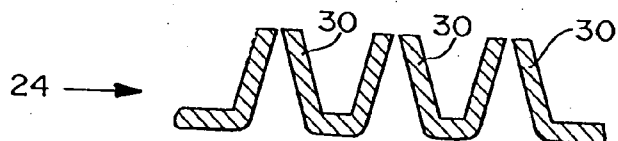

FIG. 3D

FIG. 4A

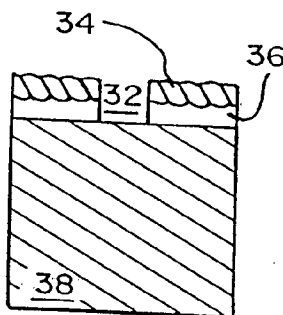

FIG. 4C

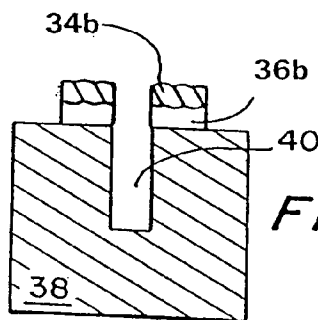

FIG. 4B

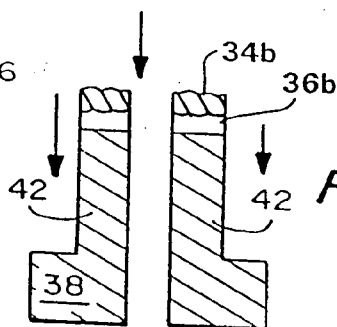
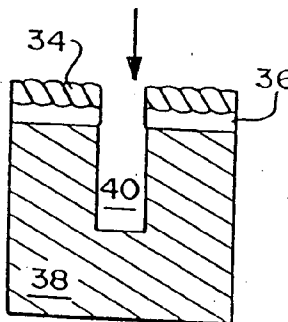
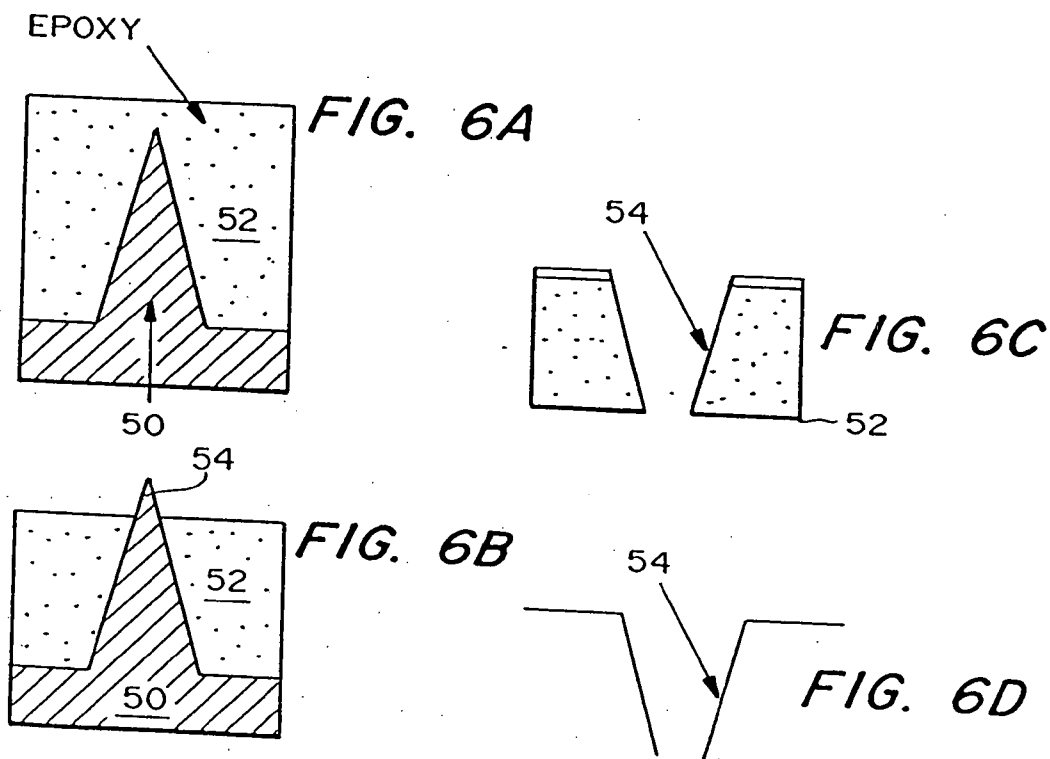
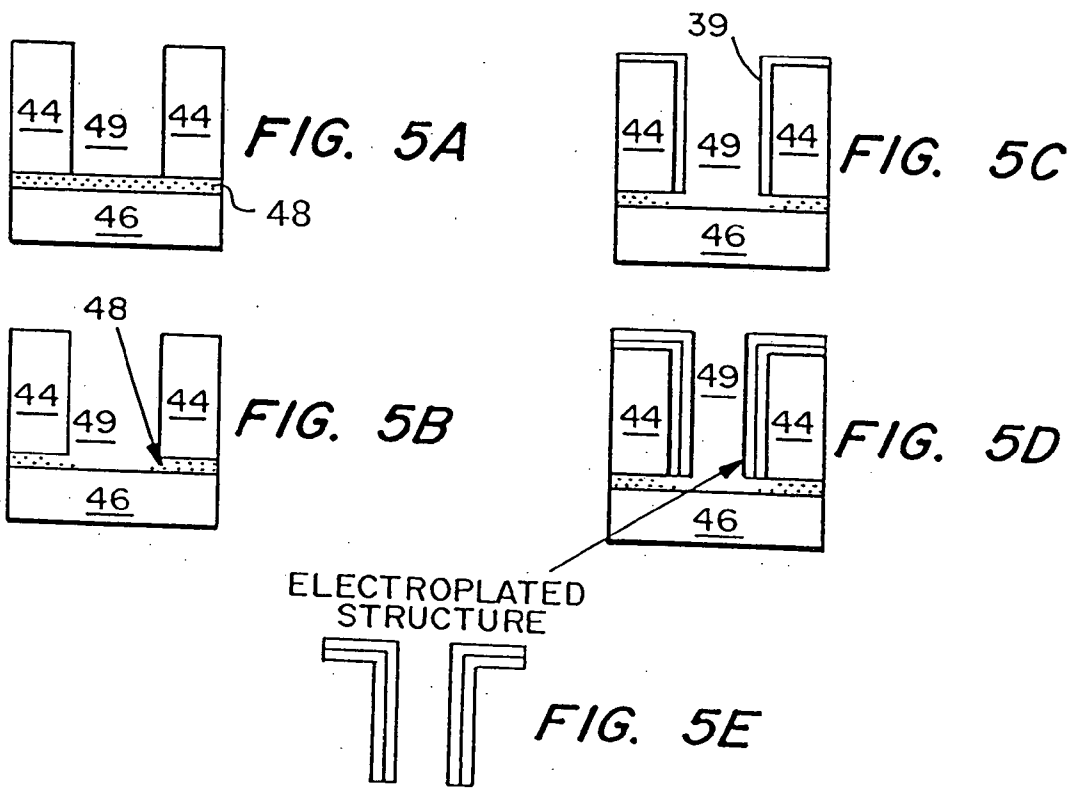

FIG. 4D



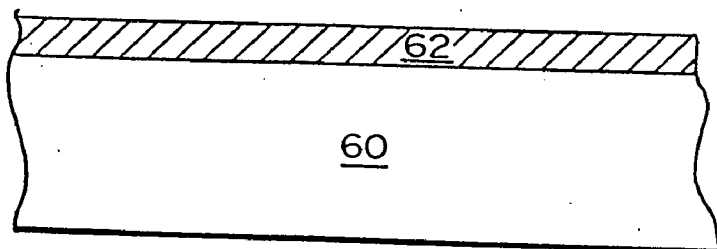

FIG. 7A

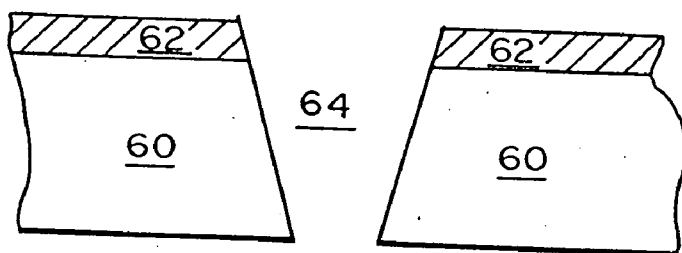

FIG. 7B

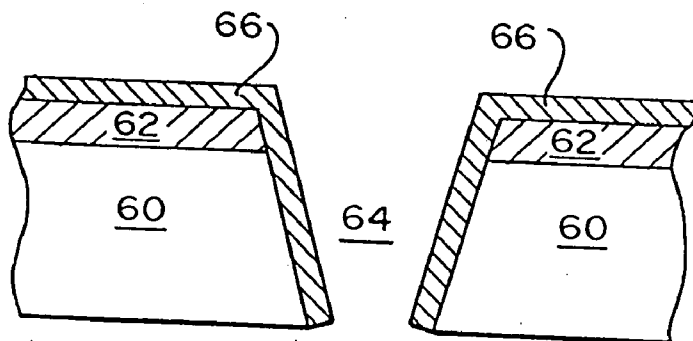

FIG. 7C

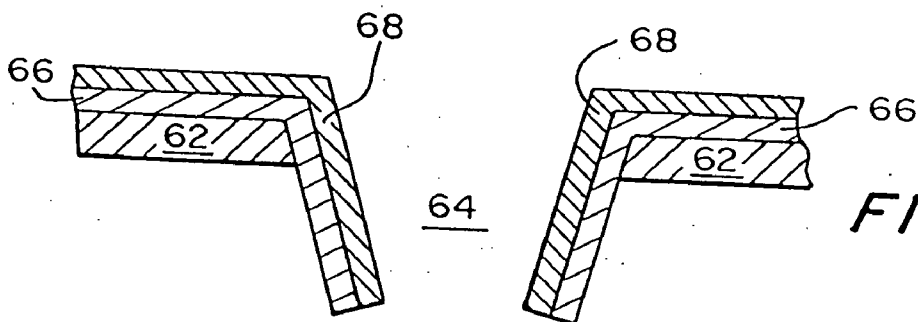

FIG. 7D

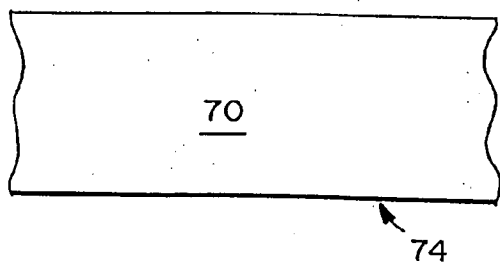

FIG. 8A

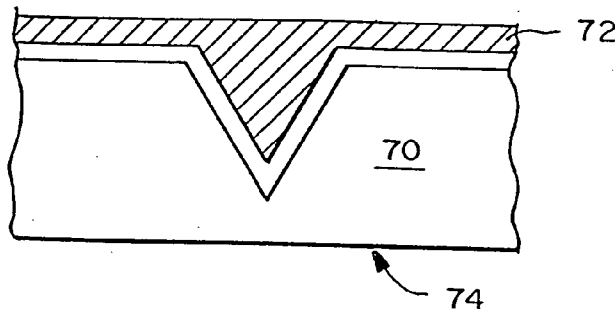

FIG. 8B

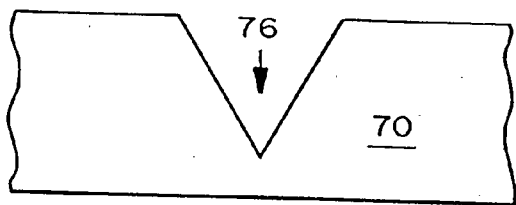

FIG. 8C

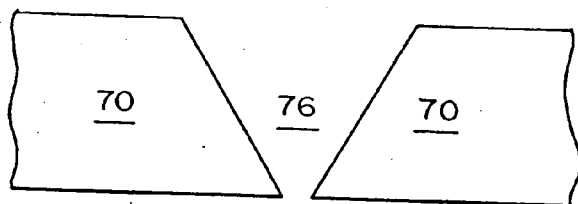

FIG. 8D

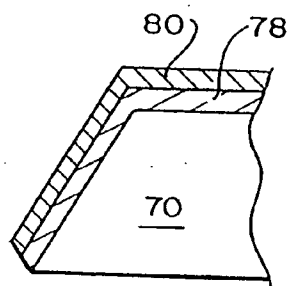
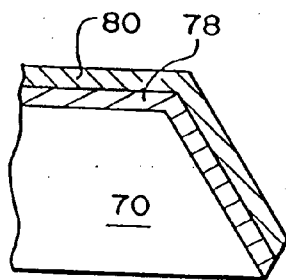

FIG. 8E

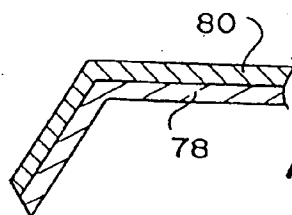
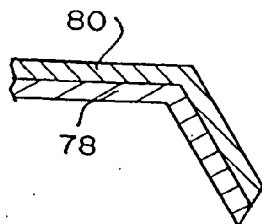

FIG. 8F

FIG. 9

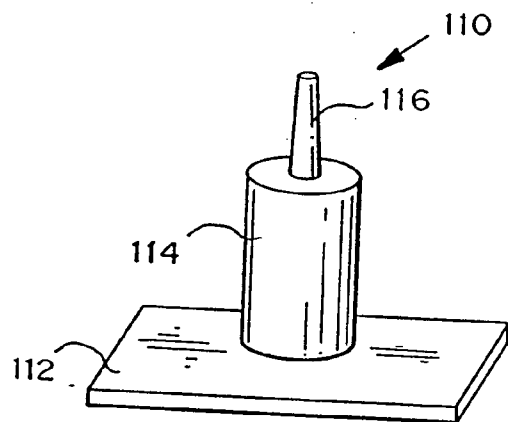
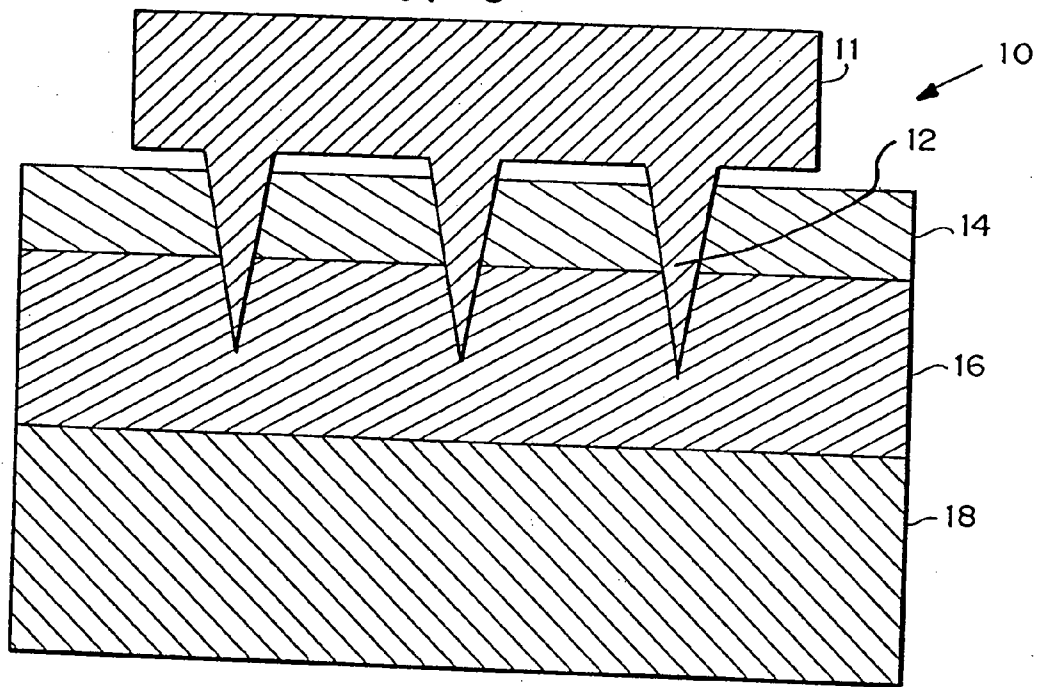

FIG. 10A

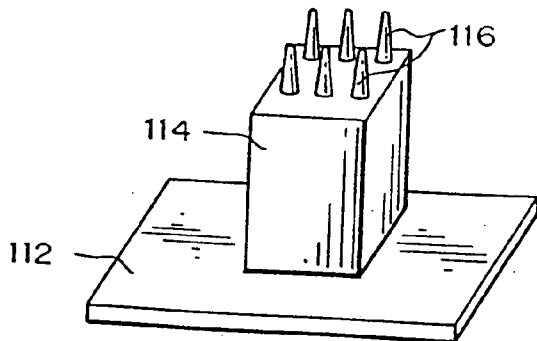

FIG. 10B

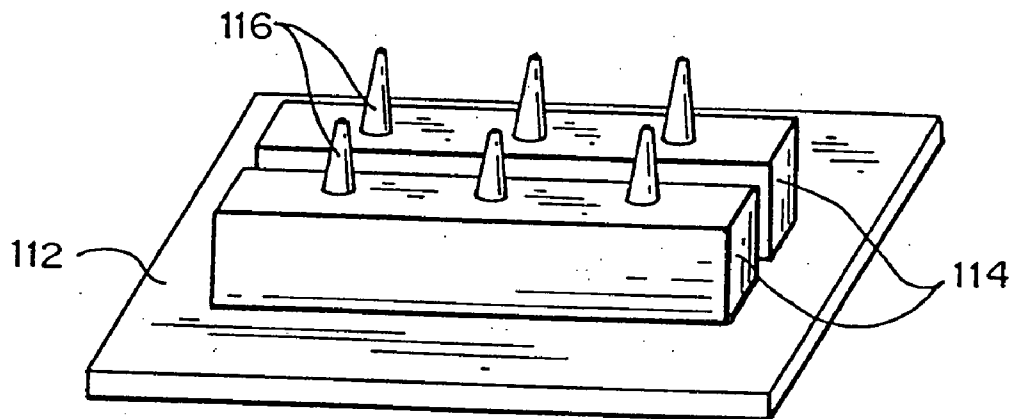

FIG. 10C

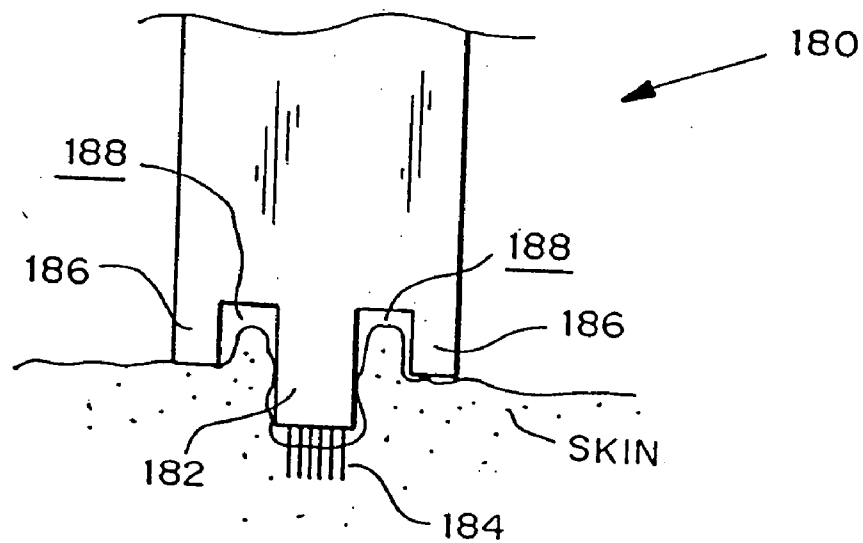

FIG. 10D

FIG. 11A

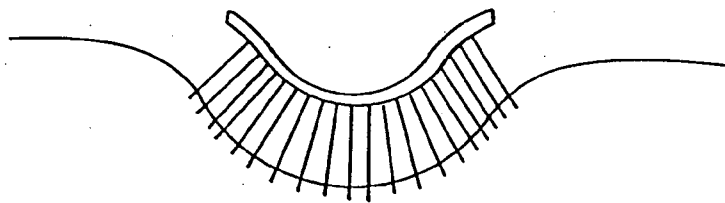

FIG. 11B

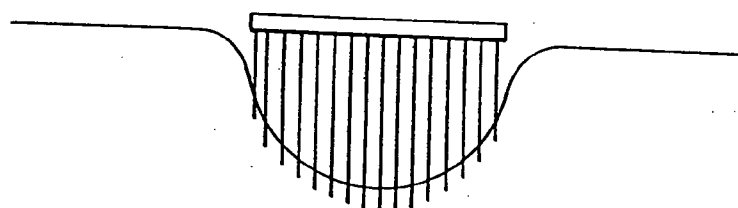
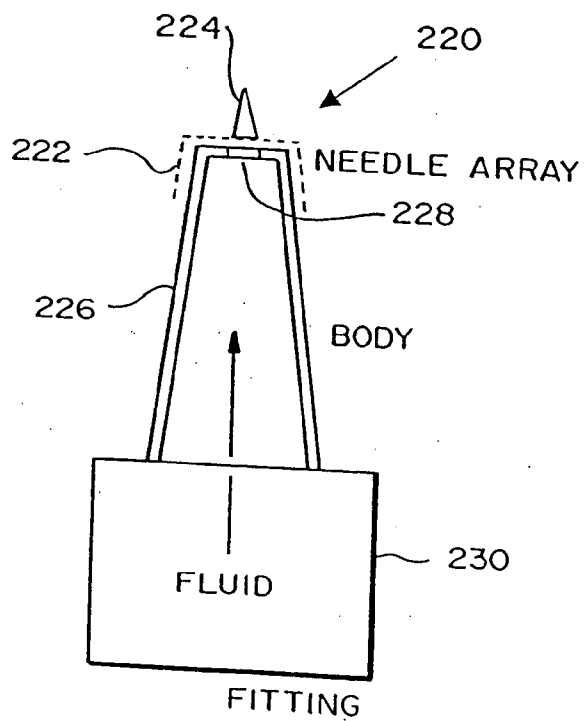

FIG. 11C



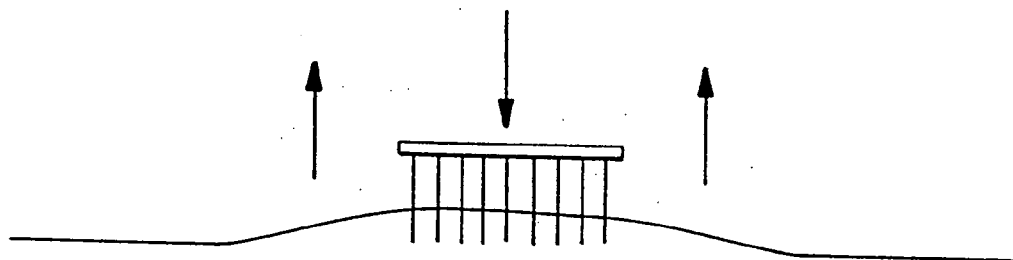

FIG. 12A



FIG. 12B

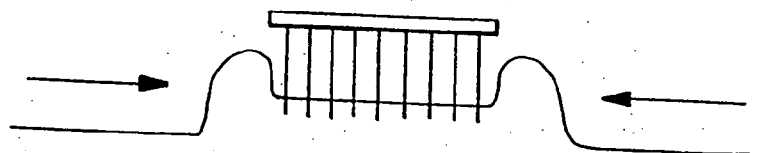
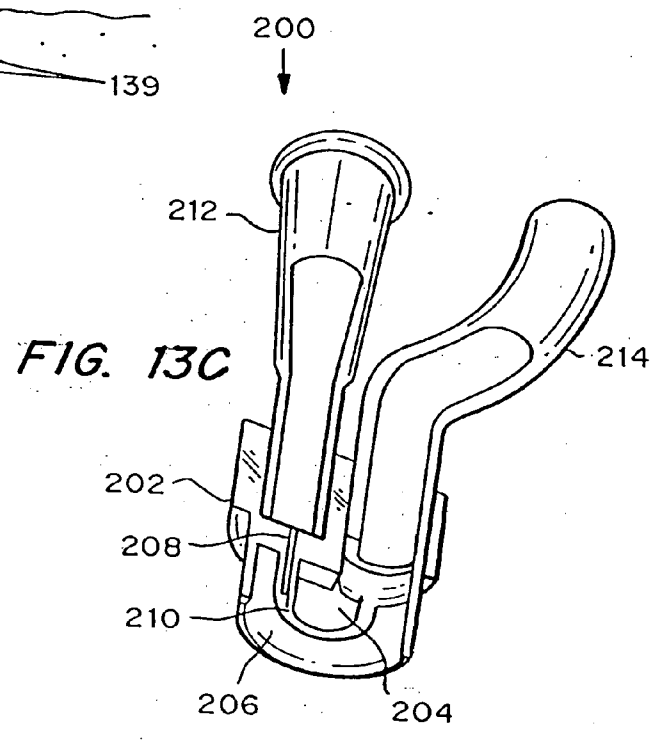
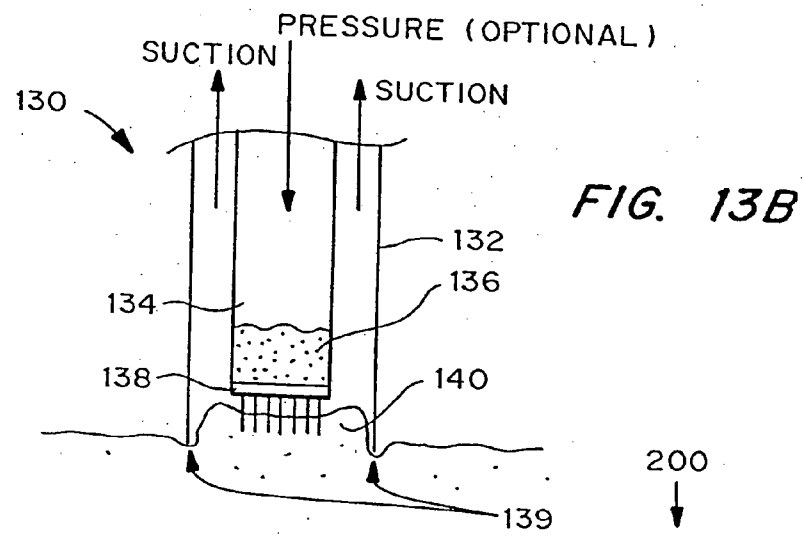
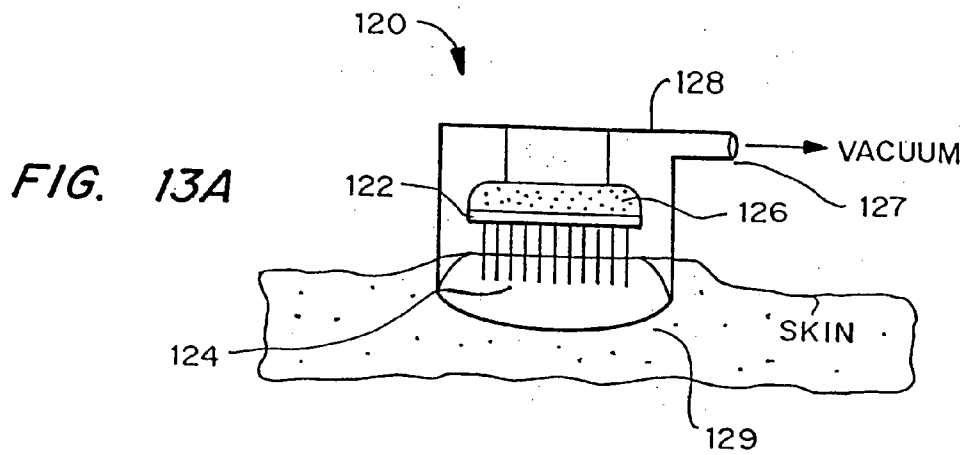

FIG. 12C



DEVICE RESTING ON SKIN SURFACE

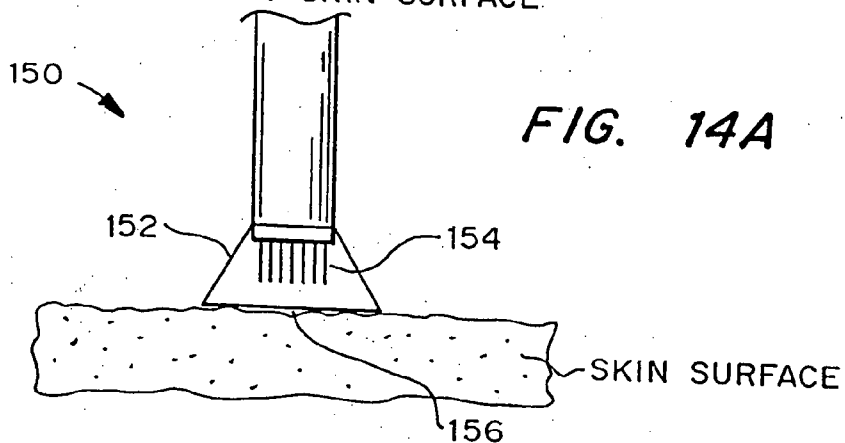

FIG. 14A

FORCE APPLIED TO MICRONEEDLE / STRETCHING DEVICE

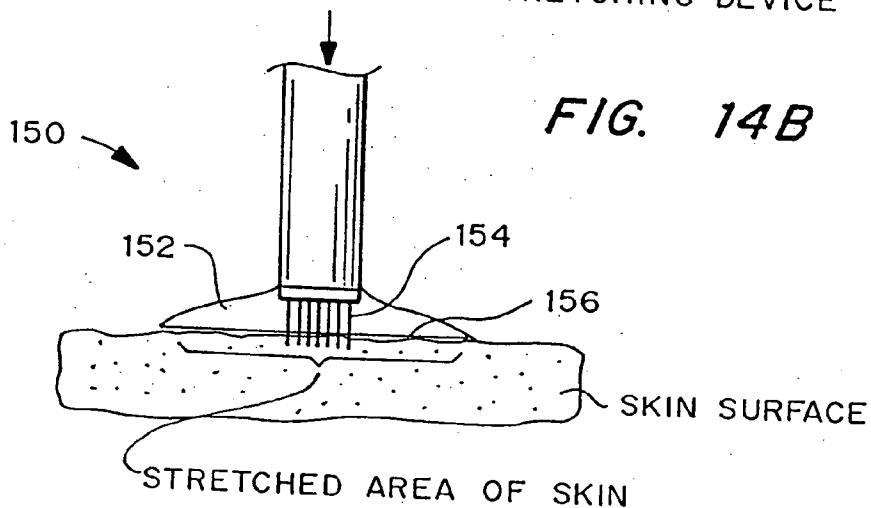

FIG. 14B

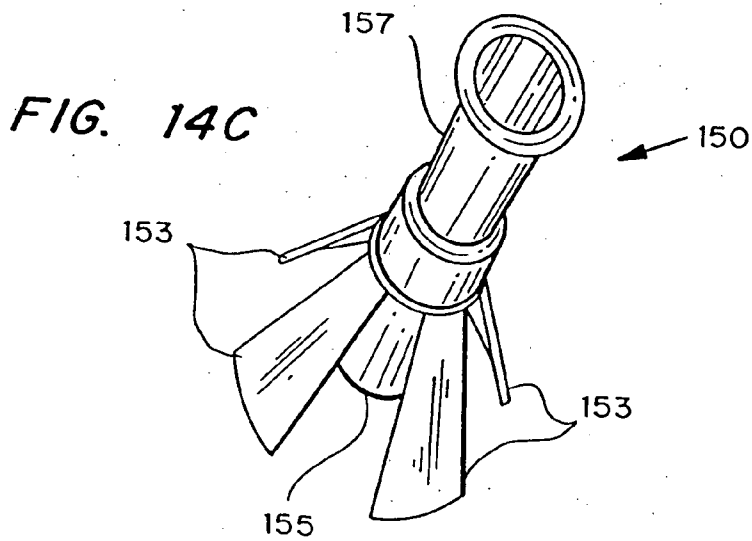

FIG. 14C

DEVICE RESTING ON SKIN SURFACE - JAWS OPEN

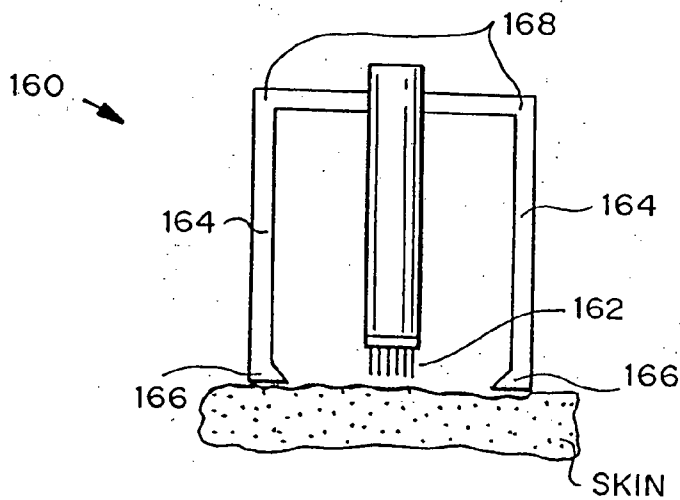

FIG. 15A

DEVICE PINCHING SKIN - JAWS CLOSED

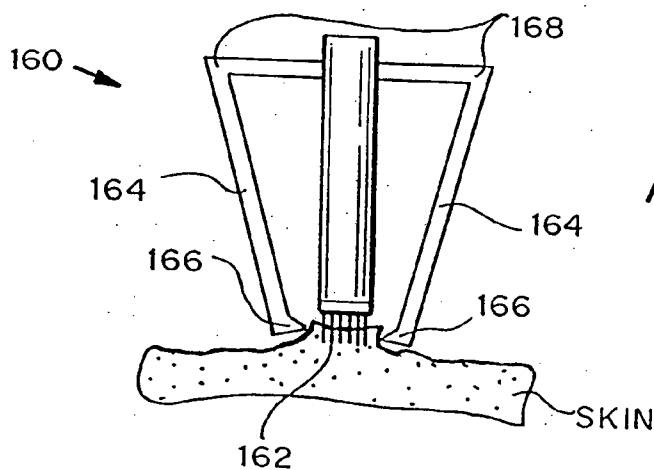

FIG. 15B

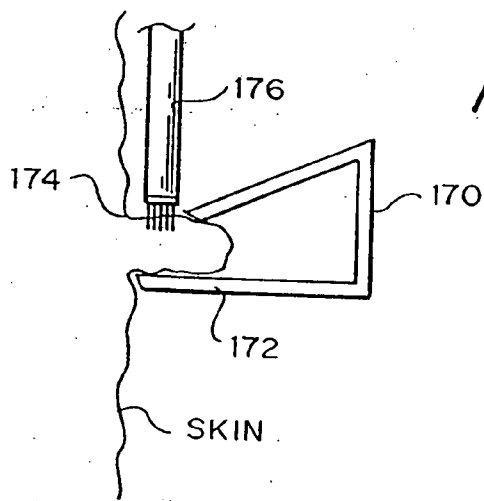

FIG. 15C

FIG. 16

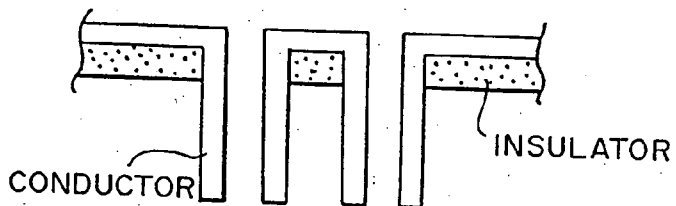

FIG. 17

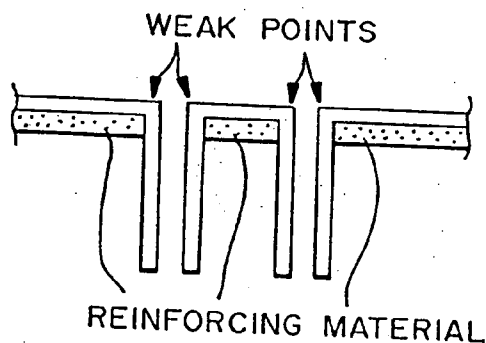

FIG. 18A

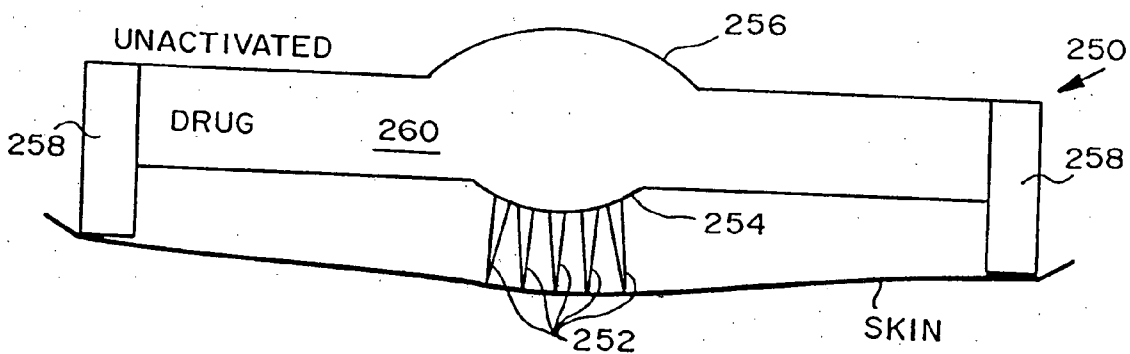

FIG. 18B

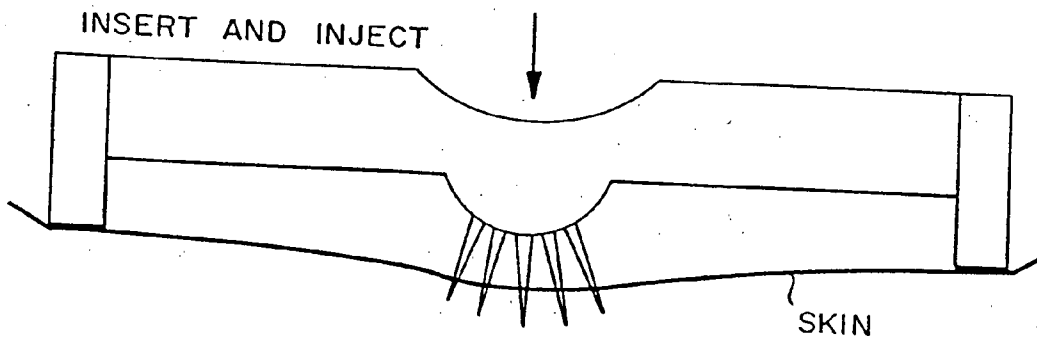
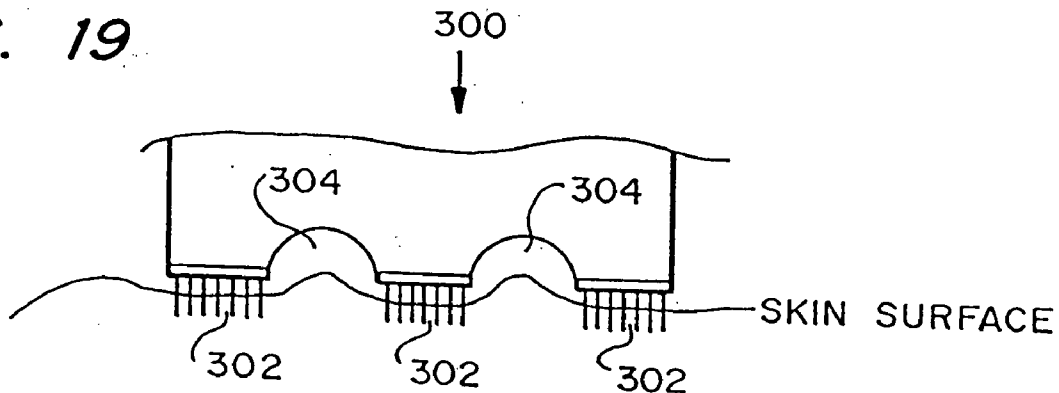

FIG. 19



DEVICES AND METHODS FOR ENHANCED MICRONEEDLE PENETRATION OF BIOLOGICAL BARRIERS

BACKGROUND OF THE INVENTION

[0001] This invention is generally in the field of devices for the transport of therapeutic or biological molecules across tissue barriers, such as for drug delivery or sampling of biological fluids.

[0002] Numerous drugs and therapeutic agents have been developed in the battle against disease and illness. However, a frequent limitation of these drugs is their delivery: how to transport drugs across biological barriers in the body (e.g., the skin, the oral mucosa, the blood-brain barrier), which normally do not transport drugs at rates that are therapeutically useful or optimal.

[0003] Drugs are commonly administered orally as pills or capsules. However, many drugs cannot be effectively delivered in this manner, due to degradation in the gastrointestinal tract and/or elimination by the liver. Moreover, some drugs cannot effectively diffuse across the intestinal mucosa. Patient compliance may also be a problem, for example, in therapies requiring that pills be taken at particular intervals over a prolonged time.

[0004] Another common technique for delivering drugs across a biological barrier is the use of a needle, such as those used with standard syringes or catheters, to transport drugs across (through) the skin. While effective for this purpose, needles generally cause pain; local damage to the skin at the site of insertion; bleeding, which increases the risk of disease transmission; and a wound sufficiently large to be a site of infection. The withdrawal of bodily fluids, such as for diagnostic purposes, using a conventional needle has these same disadvantages. Needle techniques also generally require administration by one trained in its use. The needle technique also is undesirable for long term, controlled continuous drug delivery.

[0005] Similarly, current methods of sampling biological fluids are invasive and suffer from the same disadvantages. For example, needles are not preferred for frequent routine use, such as sampling of a diabetic's blood glucose or delivery of insulin, due to the vascular damage caused by repeated punctures. No alternative methodologies are currently in use. Proposed alternatives to the needle require the use of lasers or heat to create a hole in the skin, which is inconvenient, expensive, or undesirable for repeated use.

[0006] An alternative delivery technique is the transdermal patch, which usually relies on diffusion of the drug across the skin. However, this method is not useful for many drugs, due to the poor permeability (i.e. effective barrier properties) of the skin. The rate of diffusion depends in part on the size and hydrophilicity of the drug molecules and the concentration gradient across the stratum corneum. Few drugs have the necessary physiochemical properties to be effectively delivered through the skin by passive diffusion. Iontophoresis, electroporation, ultrasound, and heat (so-called active systems) have been used in an attempt to improve the rate of delivery. While providing varying degrees of enhancement, these techniques are not suitable for all types of drugs, failing to provide the desired level of delivery. In some cases, they are also painful and inconven-

nient or impractical for continuous controlled drug delivery over a period of hours or days. Attempts have been made to design alternative devices for active transfer of drugs, or analyte to be measured, through the skin.

[0007] For example, U.S. Pat. No. 5,879,326 to Godshall et al. and PCT WO 96/37256 by Silicon Microdevices, Inc. disclose a transdermal drug delivery apparatus that includes a cutter portion having a plurality of microprotrusions, which have straight sidewalls, extending from a substrate that is in communication with a drug reservoir. In operation, the microprotrusions penetrate the skin until limited by a stop region of the substrate and then are moved parallel to the skin to create incisions. Channels in the substrate adjacent to the microprotrusions allow drug from the reservoir to flow to the skin near the area disrupted by the microprotrusions. Merely creating a wound, rather than using a needle which conveys drug through an enclosed channel into the site of administration, creates variability in dosage.

[0008] U.S. Pat. No. 5,250,023 to Lee et al. discloses a transdermal drug delivery device, which includes a plurality of needles having a diameter in the range of 50 to 400 μm . The needles are supported in a water-swellaible polymer substrate through which a drug solution permeates to contact the surface of the skin. An electric current is applied to the device to open the pathways created by the needles, following their withdrawal from the skin upon swelling of the polymer substrate.

[0009] PCT WO 93/17754 by Gross et al. discloses another transdermal drug delivery device that includes a housing having a liquid drug reservoir and a plurality of tubular elements for transporting liquid drug into the skin. The tubular elements may be in the form of hollow needles having inner diameters of less than 1 mm and an outer diameter of 1.0 mm.

[0010] While each of these devices has potential use, there remains a need for better drug delivery devices, which make smaller incisions, deliver drug with greater efficiency (greater drug delivery per quantity applied) and less variability of drug administration, and/or are easier to use. In view of these needs, microneedle devices have been developed, which are described in U.S. Ser. No. 09/095,221, filed Jun. 10, 1998, and Ser. No. 09/316,229, filed May 21, 1999, both by Prausnitz et al., which are hereby incorporated by reference. Certain embodiments of the device were found to readily penetrate skin samples in *in vitro* experiments, but not always provide uniform or complete insertion of the microneedles into some areas of the skin *in vivo*, as the stratum corneum and underlying tissues are highly deformable and elastic over much of the body.

[0011] It is therefore an object of the present invention to provide methods and devices for improving the control of microneedle insertion into the body of a patient.

[0012] It is another object of the present invention to provide a microneedle device producing improved microneedle insertion for relatively painless, controlled, safe, convenient transdermal delivery of drugs.

[0013] It is a further object of the present invention to provide a microneedle device producing improved microneedle insertion for controlled sampling of biological fluids in a minimally-invasive, painless, and convenient manner.

SUMMARY OF THE INVENTION

[0014] Microneedle devices and methods of use thereof are provided for the enhanced transport of molecules, including drugs and biological molecules, across tissue by improving the interaction of an array of microneedles and a deformable, elastic biological barrier, such as human skin. The devices and methods act to (1) limit the elasticity, (2) adapt to the elasticity, (3) utilize alternate ways of creating the holes for the microneedles to penetrate the biological barrier, other than the simply direct pressure of the microneedle substrate to the barrier surface, or (4) any combination of these methods.

[0015] In preferred embodiments for limiting the elasticity of skin, the microneedle device includes features suitable for stretching, pulling, or pinching the skin to present a more rigid, less deformable, surface in the area to which the microneedles are applied (i.e. penetrate). For example, a vacuum can be applied to the area of the skin at the site of microneedle application to pull it taut and/or pull the skin onto the tips of the microneedles. Alternatively or in addition, the elasticity of skin can be reduced by applying a thin film or membrane over the skin surface at the site of application, so as to keep the skin tight, limiting the ability of the skin to stretch at the application site. The microneedles are then pushed through the film or membrane and into the skin.

[0016] In preferred embodiments for adapting the device to the elasticity of skin, the microneedles of the device include individual extensions or are provided in a curved three dimensional array, for example, by using a flexible substrate and/or varying the height of the microneedles in the array. In another embodiment, the microneedles are applied to the skin surface at an increased velocity, thereby reducing the time available for the stratum corneum and underlying tissues to deform from contact with the tips or entire length of the microneedles.

[0017] In a preferred embodiment for creating holes in the skin for microneedles, tiny holes are burned into the skin, for example, by heating of the tips of the microneedles and/or by using a laser. In another embodiment, a focused blast of high pressure gas is used to create the holes.

[0018] Essentially all of the microneedle devices and methods described herein can be adapted to vibrate the microneedles and/or the skin to further enhance penetration. In a preferred embodiment, the microneedles include a lubricating material coated onto or incorporated into the microneedles.

BRIEF DESCRIPTION OF THE DRAWINGS

[0019] FIGS. 1a-e are side cross-sectional views of a method for making hollow microneedles.

[0020] FIGS. 2a-g are side cross-sectional views of a method for making a hollow microneedle.

[0021] FIGS. 3a-d are side cross-sectional views illustrating a preferred method for making hollow microneedles.

[0022] FIGS. 4a-d are side cross-sectional views illustrating a preferred method for making hollow silicon microtubes.

[0023] FIGS. 5a-e are side cross-sectional views illustrating a preferred method for making hollow metal microtubes.

[0024] FIGS. 6a-d are side cross-sectional views illustrating a preferred method for making tapered metal microneedles.

[0025] FIGS. 7a-d are side cross-sectional views illustrating a method for making tapered microneedles using laser-formed molds.

[0026] FIGS. 8a-f are side cross-sectional views illustrating a second method for making tapered microneedles using laser-formed molds.

[0027] FIG. 9 is a side elevational view of a schematic of an embodiment of the microneedle device inserted into undeformed skin.

[0028] FIGS. 10a-d are illustrations of microneedle devices having various embodiments of microneedle extensions.

[0029] FIGS. 11a-c are cross-sectional views illustrating microneedle devices having curved substrates (11a), varying microneedle height (11b), and linear microneedle arrays (11c).

[0030] FIGS. 12a-c are cross-sectional views illustrating preferred microneedle devices inserted into skin with altered elasticity.

[0031] FIGS. 13a-c are cross-sectional views illustrating preferred embodiments of microneedle devices which can apply suction to skin at the site of insertion.

[0032] FIGS. 14a-c are cross-sectional (14a-b) and perspective (14c) views illustrating preferred embodiments of microneedle devices which stretch the skin at the site of insertion.

[0033] FIGS. 15a-c are cross-sectional views illustrating examples of microneedle devices which pinch the skin at the site of insertion.

[0034] FIG. 16 is a cross-sectional view of a preferred embodiment of a microneedle device for use in localized heating of skin.

[0035] FIG. 17 is a cross-sectional view of a preferred embodiment of a microneedle device having a microneedle reinforcing layer.

[0036] FIGS. 18a-b are cross-sectional views of a preferred embodiment of a microneedle device having a flexible substrate in an unactivated position (18a) and an activated position (18b).

[0037] FIG. 19 is a cross-sectional view a preferred embodiment of a microneedle device having arrays of microneedles with spaces between the arrays.

DETAILED DESCRIPTION OF THE INVENTION

[0038] 1. Biological Barriers

[0039] The devices disclosed herein are useful in transport of material into or across biological barriers including the skin (or parts thereof); the blood-brain barrier; mucosal tissue (e.g., oral, nasal, ocular, vaginal, urethral, gastrointestinal, respiratory); blood vessels; lymphatic vessels; or cell membranes (e.g., for the introduction of material into the interior of a cell or cells). The biological barriers can be in humans or other types of animals, as well as in plants,

insects, or other organisms, including bacteria, yeast, fungi, and embryos. The microneedle devices can be applied to tissue internally with the aid of a catheter or laparoscope. For certain applications, such as for drug delivery to an internal tissue, the devices can be surgically implanted.

[0040] In a preferred embodiment, the microneedle device disclosed herein is applied to skin. The stratum corneum is the outer layer, generally between 10 and 50 cells, or between 10 and 20 μm thick. Unlike other tissue in the body, the stratum corneum contains “cells” (called keratinocytes) filled with bundles of cross-linked keratin and keratohyalin surrounded by an extracellular matrix of lipids. It is this structure that is believed to give skin its barrier properties, which prevents therapeutic transdermal administration of many drugs. Below the stratum corneum is the viable epidermis, which is between 50 and 100 μm thick. The viable epidermis contains no blood vessels, and it exchanges metabolites by diffusion to and from the dermis. Beneath the viable epidermis is the dermis, which is between 1 and 3 mm thick and contains blood vessels, lymphatics, and nerves.

[0041] As used herein, references to using the microneedle devices on “skin” also include using the microneedle devices with other biological barriers unless expressly limited to only skin.

[0042] 2. The Microneedle Device

[0043] The microneedle devices disclosed herein include a substrate; one or more microneedles; and, optionally, a reservoir for delivery of drugs or collection of analyte, as well as pump(s), sensor(s), and/or microprocessor(s) to control the interaction of the foregoing. The microneedle device preferably includes penetration enhancing features to alter or adapt to deformable and elastic biological barriers, such as the skin over much of the human body.

[0044] a. Substrate

[0045] The substrate of the device can be constructed from a variety of materials, including metals, ceramics, semiconductors, organics, polymers, and composites. The substrate includes the base to which the microneedles are attached or integrally formed. A reservoir may also be attached to the substrate.

[0046] In one embodiment of the device, the substrate is formed from a thin, rigid material that is sufficiently stiff so as to force the attached microneedles through the biological barrier in such areas where the barrier resists deformation by the microneedles.

[0047] In a preferred embodiment of the device, the substrate is formed from flexible materials to allow the device to fit the contours of the biological barrier, and to adapt to barrier deformations that may occur when the microneedle device is applied. A flexible device further facilitates more consistent penetration during use, since penetration can be limited by deviations in the attachment surface. For example, the surface of human skin is not flat due to dermatoglyphics, i.e. tiny wrinkles, and hair, and is highly deformable. The flexible substrate can be deformed mechanically (for example, using an actuator or simply by fluid pressure) in order to pierce the biological barrier.

[0048] b. Microneedle

[0049] The microneedles of the device can be constructed from a variety of materials, including metals, ceramics,

semiconductors, organics, polymers, and composites. Preferred materials of construction include pharmaceutical grade stainless steel, gold, titanium, nickel, iron, gold, tin, chromium, copper, alloys of these or other metals, silicon, silicon dioxide, and polymers. Representative biodegradable polymers include polymers of hydroxy acids such as lactic acid and glycolic acid polylactide, polyglycolide, polylactide-co-glycolide, and copolymers with PEG, polyanhydrides, poly(ortho)esters, polyurethanes, poly(butyric acid), poly(valeric acid), and poly(lactide-co-caprolactone). Representative non-biodegradable polymers include polycarbonate, polymethacrylic acid, ethylenevinyl acetate, polytetrafluoroethylene (TEFLON™), and polyesters.

[0050] Generally, the microneedles should have the mechanical strength to remain intact for delivery of drugs, or serve as a conduit for the collection of biological fluid, while being inserted into the skin, while remaining in place for up to a number of days, and while being removed. In embodiments where the microneedles are formed of biodegradable polymers, however, this mechanical requirement is less stringent, since the microneedles or tips thereof can break off, for example in the skin, and will biodegrade. Nonetheless, even a biodegradable microneedle still needs to remain intact at least long enough for the microneedle to serve its intended purpose (e.g., its conduit function). Therefore, biodegradable microneedles can provide an increased level of safety, as compared to nonbiodegradable ones.

[0051] The microneedles can be formed of a nonporous solid, a porous solid (with or without a sealed coating or exterior portion), or hollow. As used herein, the term “porous” means having pores or voids throughout at least a portion of the microneedle structure, sufficiently large and sufficiently interconnected to permit passage of fluid and/or solid materials through the microneedle. As used herein, the term “hollow” means having one or more substantially annular bores or channels through the interior of the microneedle structure, having a diameter sufficiently large to permit passage of fluid and/or solid materials through the microneedle. The annular bores may extend throughout all or a portion of the needle in the direction of the tip to the base, extending parallel to the direction of the needle or branching or exiting at a side of the needle, as appropriate. A solid or porous microneedle can be hollow. One of skill in the art can select the appropriate porosity and/or bore features required for specific applications. For example, one can adjust the pore size or bore diameter to permit passage of the particular material to be transported through the microneedle device. The inner surface of the bore of hollow microneedles can be made rough to enhance cell membrane disruption for those applications in which cell disruption is useful.

[0052] The microneedles can have straight or tapered shafts. A hollow microneedle that has a substantially uniform diameter, which needle does not taper to a point, is referred to herein as a “microtube.” As used herein, the term “microneedle” includes both microtubes and tapered needles unless otherwise indicated. In one embodiment, the diameter of the microneedle is greatest at the base end of the microneedle and tapers to a point at the end distal the base. The microneedle can also be fabricated to have a shaft that includes both a straight (untapered) portion and a tapered portion.

[0053] The microneedles can be formed with shafts that have a circular cross-section in the perpendicular, or the

cross-section can be non-circular. For example, the cross-section of the microneedle can be polygonal (e.g. star-shaped, square, triangular), oblong, or another shape. The shaft can have one or more bores. The cross-sectional dimensions typically are between about 10 nm and 1 mm, preferably between 1 micron and 200 microns, and more preferably between 10 and 100 μm . The outer diameter is typically between about 10 μm and about 100 μm , and the inner diameter is typically between about 3 μm and about 80 μm .

[0054] The length of the microneedles typically is between about 1 μm and 1 mm, preferably between 10 microns and 500 microns. The length is selected for the particular application, accounting for both an inserted and uninserted portion. An array of microneedles can include a mixture of microneedles having, for example, various lengths, outer diameters, inner diameters, cross-sectional shapes, and spacing between the microneedles.

[0055] The microneedles can be oriented perpendicular or at an angle to the substrate. Preferably, the microneedles are oriented perpendicular to the substrate so that a larger density of microneedles per unit area of substrate is provided. An array of microneedles can include a mixture of microneedle orientations, heights, or other parameters.

[0056] c. Reservoir

[0057] The microneedle device may include a reservoir in communication with the microneedles. The reservoir can be attached to the substrate by any suitable means. In a preferred embodiment, the reservoir is attached to the back of the substrate (opposite the microneedles) around the periphery, using an adhesive agent (e.g., glue). A gasket may also be used to facilitate formation of a fluid-tight seal.

[0058] In a preferred embodiment, the reservoir contains drug, for delivery through the microneedles. The reservoir may be a hollow vessel, a porous matrix, or a solid form including drug which is transported therefrom. The reservoir can be formed from a variety of materials that are compatible with the drug or biological fluid contained therein. Preferred materials include natural and synthetic polymers, metals, ceramics, semiconductors, organics, and composites. In one embodiment, the reservoir is a standard syringe.

[0059] The microneedle device can include one or a plurality of chambers for storing materials to be delivered. In the embodiment having multiple chambers, each can be in fluid connection with all or a portion of the microneedles of the device array. In one embodiment, at least two chambers are used to separately contain drug (e.g., a lyophilized drug, such as a vaccine) and an administration vehicle (e.g., saline) in order to prevent or minimize degradation during storage. Immediately before use, the contents of the chambers are mixed. Mixing can be triggered by any means, including, for example, mechanical disruption (i.e. puncturing or breaking), changing the porosity, or electrochemical degradation of the walls or membranes separating the chambers. In another embodiment, a single device is used to deliver different drugs, which are stored separately in different chambers. In this embodiment, the rate of delivery of each drug can be independently controlled.

[0060] In a preferred embodiment, the reservoir should be in direct contact with the microneedles and have holes through which drug could exit the reservoir and flow into the interior

of hollow or porous microneedles. In another preferred embodiment, the reservoir has holes which permit the drug to transport out of the reservoir and onto the skin surface. From there, drug is transported into the skin, either through hollow or porous microneedles, along the sides of solid microneedles, or through pathways created by microneedles in the skin.

[0061] d. Transport Control Components

[0062] The microneedle device also must be capable of transporting material across the barrier at a useful rate. For example, the microneedle device must be capable of delivering drug across the skin at a rate sufficient to be therapeutically useful. The device may include a housing with microelectronics and other micromachined structures to control the rate of delivery either according to a preprogrammed schedule or through active interface with the patient, a healthcare professional, or a biosensor. The rate can be controlled by manipulating a variety of factors, including the characteristics of the drug formulation to be delivered (e.g., its viscosity, electric charge, and chemical composition); the dimensions of each microneedle (e.g., its outer diameter and the area of porous or hollow openings); the number of microneedles in the device; the application of a driving force (e.g., a concentration gradient, a voltage gradient, a pressure gradient); and the use of a valve.

[0063] The rate also can be controlled by interposing between the drug in the reservoir and the opening(s) at the base end of the microneedle polymeric or other materials selected for their diffusion characteristics. For example, the material composition and layer thickness can be manipulated using methods known in the art to vary the rate of diffusion of the drug of interest through the material, thereby controlling the rate at which the drug flows from the reservoir through the microneedle and into the tissue.

[0064] Transportation of molecules through the microneedles can be controlled or monitored using, for example, various combinations of valves, pumps, sensors, actuators, and microprocessors. These components can be produced using standard manufacturing or microfabrication techniques. Actuators that may be useful with the microneedle devices disclosed herein include micropumps, microvalves, and positioners. In a preferred embodiment, a microprocessor is programmed to control a pump or valve, thereby controlling the rate of delivery.

[0065] Flow of molecules through the microneedles can occur based on diffusion, capillary action, or can be induced using conventional mechanical pumps or nonmechanical driving forces, such as electroosmosis or electrophoresis, or convection. For example, in electroosmosis, electrodes are positioned on the biological barrier surface, one or more microneedles, and/or the substrate adjacent the needles, to create a convective flow which carries oppositely charged ionic species and/or neutral molecules toward or into the biological barrier. In a preferred embodiment, the microneedle device is used in combination with another mechanism that enhances the permeability of the biological barrier, for example by increasing cell uptake or membrane disruption, using electric fields, ultrasound, chemical enhancers, vacuum viruses, pH, heat and/or light.

[0066] Passage of the microneedles, or drug to be transported via the microneedles, can be manipulated by shaping

the microneedle surface, or by selection of the material forming the microneedle surface (which could be a coating rather than the microneedle per se). For example, one or more grooves on the outside surface of the microneedles can be used to direct the passage of drug, particularly in a liquid state. Alternatively, the physical surface properties of the microneedle can be manipulated to either promote or inhibit transport of material along the microneedle surface, such as by controlling hydrophilicity or hydrophobicity.

[0067] The flow of molecules can be regulated using a wide range of valves or gates. These valves can be the type that are selectively and repeatedly opened and closed, or they can be single-use types. For example, in a disposable, single-use drug delivery device, a fracturable barrier or one-way gate may be installed in the device between the reservoir and the opening of the microneedles. When ready to use, the barrier can be broken or gate opened to permit flow through the microneedles. Other valves or gates used in the microneedle devices can be activated thermally, electrochemically, mechanically, or magnetically to selectively initiate, modulate, or stop the flow of molecules through the needles. In a preferred embodiment, flow is controlled by using a rate-limiting membrane as a “valve.”

[0068] The microneedle devices can further include a flowmeter or other means to monitor flow through the microneedles and to coordinate use of the pumps and valves.

[0069] e. Sensors

[0070] Useful sensors may include sensors of pressure, temperature, chemicals, and/or electromagnetic fields. Biosensors can be located on the microneedle surface, inside a hollow or porous microneedle, or inside a device in communication with the body tissue via the microneedle (solid, hollow, or porous). These microneedle biosensors can include four classes of principal transducers: potentiometric, amperometric, optical, and physiochemical. An amperometric sensor monitors currents generated when electrons are exchanged between a biological system and an electrode. Blood glucose sensors frequently are of this type.

[0071] The microneedle may function as a conduit for fluids, solutes, electric charge, light, or other materials. In one embodiment, hollow microneedles can be filled with a substance, such as a gel, that has a sensing functionality associated with it. In an application for sensing based on binding to a substrate or reaction mediated by an enzyme, the substrate or enzyme can be immobilized in the needle interior, which would be especially useful in a porous needle to create an integral needle/sensor.

[0072] Wave guides can be incorporated into the microneedle device to direct light to a specific location, or for detection, for example, using means such as a pH dye for color evaluation. Similarly, heat, electricity, light or other energy forms may be precisely transmitted to directly stimulate, damage, or heal a specific tissue or intermediary (e.g., tattoo removal for dark skinned persons), or diagnostic purposes, such as measurement of blood glucose based on IR spectra or by chromatographic means, measuring a color change in the presence of immobilized glucose oxidase in combination with an appropriate substrate.

[0073] f. Attachment Features

[0074] A collar or flange also can be provided with the device, for example, around the periphery of the substrate or

the base. It preferably is attached to the device, but alternatively can be formed as an integral part of the substrate, for example by forming microneedles only near the center of an “oversized” substrate. The collar can also emanate from other parts of the device. The collar can provide an interface to attach the microneedle array to the rest of the device, and can facilitate handling of the smaller devices.

[0075] In a preferred embodiment, the microneedle device includes an adhesive to temporarily secure the device to the surface of the biological barrier. The adhesive can be essentially anywhere on the device to facilitate contact with the biological barrier. For example, the adhesive can be on the surface of the collar (same side as microneedles), on the surface of the substrate between the microneedles (near the base of the microneedles), or a combination thereof.

[0076] In one embodiment, the microneedle device is incorporated into an arm (e.g., wrist) band. The arm band can be conveniently worn by a patient for drug delivery, sampling of biological fluids, or both over a prolonged period of time, such as several hours.

[0077] g. Transdermal Microneedle Device

[0078] FIG. 9 is a side elevational view of a schematic of an embodiment of the microneedle device inserted into undeformed skin. The device 10 includes an upper portion or substrate 11 from which a plurality of microneedles 12 protrude. The height of the upper portion 11 is between about 1 μm and 1 cm, and the width of the upper portion is between about 1 mm and 10 cm. The upper portion 11 of the device can be solid or hollow, and may include multiple compartments. In a preferred embodiment for drug delivery, the upper portion 11 contains one or more drugs to be delivered. It is also preferred that the upper portion include one or more sensors and/or an apparatus (e.g., pump or electrode) to drive (provide/direct the force) transport of the drug or other molecules.

[0079] The height (or length) of the microneedles 12 generally is between about 1 μm and 1 mm. The diameter and length both affect pain as well as functional properties of the needles. In one embodiment for transdermal applications, the “insertion depth” of the microneedles 12 is less than about 100 μm , more preferably about 30 μm , so that insertion of the microneedles 12 into the skin through the stratum corneum 14 does not penetrate through the epidermis 16 into the dermis 18 (as described below), thereby avoiding contacting nerves and reducing the potential for causing pain. In such applications, the actual length of the microneedles may be longer, since the portion of the microneedles distal the tip may not be inserted into the skin; the uninserted length depends on the particular device design and configuration. The actual (overall) height or length of microneedles 12 should be equal to the insertion depth plus the uninserted length. Other embodiments using sufficiently small microneedles may penetrate into the dermis without causing pain.

[0080] The diameter of each microneedle 12 generally is between about 10 nm and 1 mm, and preferably leaves a residual hole (following microneedle insertion and withdrawal) of less than about 1 μm , to avoid making a hole which would allow bacteria to enter the penetration wound. The actual microneedle diameter should be larger than 1 μm , since the hole likely will contract following withdrawal of

the microneedle. The diameter of microneedle **12** more preferably is between about $1\ \mu\text{m}$ and $100\ \mu\text{m}$. Larger diameter and longer microneedles are acceptable, so long as the microneedle can penetrate the biological barrier to the desired depth and the hole remaining in the skin or other tissue following withdrawal of the microneedle is sufficiently small, preferably small enough to exclude bacterial entry. The microneedles **12** can be solid or porous, and can include one or more bores connected to upper portion **11**.

[0081] h. Microneedle Penetration Enhancing Features

[0082] In a preferred embodiment, the microneedle devices include features which improve penetration of the microneedles into deformable, elastic biological barriers, such as human skin. As used herein, "improved penetration" refers to providing more uniform, better controlled insertion of microneedles, for example, as compared to manual insertion of a microneedle or array of microneedles into skin without compensation (in the device design or site preparation or both) for deformation of the skin at the intended site of insertion. This is particularly critical for devices which include a three dimensional array of the microneedles. These features typically function to (1) adapt to the deformation, (2) limit the deformation, and/or (3) utilize alternate ways of creating the holes in the biological barrier for the microneedles to enter. These penetration enhancing techniques generally can be used with solid, porous, or hollow microneedles. Examples of penetration enhancing features include the following:

[0083] i. Microneedle Extensions

[0084] In a preferred embodiment for adapting the device to the elasticity of skin, the microneedles of the device include extensions, also called protrusion enhancers. One solution to enhance microneedle penetration would be to make the microneedles much longer. However, very tall, small diameter microneedles would tend to be structurally fragile. Therefore, a relatively wider, yet tall base is provided between the substrate and the microneedle to increase the length while maintaining structural integrity of the microneedles. The extensions can be fabricated using the same microfabrication techniques described herein or other conventional fabrication techniques, and typically are made integrally with the substrate and microneedles. The extensions can be of any cross-sectional shape, are typically between about $500\ \mu\text{m}$ and $10\ \text{mm}$ in height, and generally are at least about $200\ \mu\text{m}$ in diameter for a single needle/single extension configuration. A single extension can support one or more microneedles.

[0085] The extensions also can be designed to function as a penetration stop or limiter, to limit the depth of microneedle penetration.

[0086] **FIGS. 10a-c** illustrate several non-limiting embodiments of the extensions. Device **110** includes substrate **112**, extension **114**, and microneedle(s) **116**. The figures show a single needle/single extension configuration (**10a**), a multiple needle/single extension configuration (**10b**), and a multiple needle/multiple extension configuration (**10c**). The microneedle devices can include arrays of microneedles and extensions in essentially any combination and number.

[0087] **FIG. 10d** illustrates an embodiment of a microneedle device **180** having extension **182** terminating in

microneedle array **184**. The device also includes shoulder **186** and key (cutout) **188**, which serve to control stretching of the skin at the site of microneedle insertion to enhance penetration. Specifically, the skin stretches in the key **188** as the microneedle device **180** is pushed in, while shoulder **186** simultaneously limits the area of skin being stretched.

[0088] ii. Optimized Microneedle Spacing

[0089] In another embodiment to adapt to the deformability of skin, the microneedle device includes arrays of microneedles having spaces between the microneedles or between arrays of microneedles, wherein the spacings permit areas of the skin to fill the spaces in order to enhance microneedle contact with adjacent areas of the skin. The spacing is designed to adapt to the skin's radius of curvature to overcome the penetration problem.

[0090] **FIG. 19** illustrates a microneedle device **300** having arrays of microneedles **302** with spaces **304** between the arrays. Spaces **304** have a size between about one and ten times, preferably between about one and two times, the size of the arrays **302**. This spacing effect can be achieved using some configurations of the microneedle extensions described above.

[0091] iii. Linear and Curved Arrays of Microneedles

[0092] In another embodiment for adapting the device to the elasticity of skin, the microneedles are provided in a curved three dimensional array. For example, the microneedle device can have a rigid substrate which forms a curved, rather than planar, surface. The substrate can be, for example, hemispherical or elliptical. The device, by presenting the needles with a curved surface, can provide improved uniformity of penetration among the microneedles of an array, as illustrated in **FIG. 11a**. This same effect also can be achieved by varying the height of the microneedles in the array having a planar substrate, as shown in **FIG. 11b**.

[0093] In a preferred embodiment, two dimensional (i.e. linear) arrays are used. A preferred embodiment of a linear array microneedle device is shown in **FIG. 11c**. Device **220** includes substrate **222**, which is formed into a U-shape, and an array of microneedles **224** at the apex of substrate **222**. The substrate/microneedle portion is mounted over the end of a slotted holder **226**. Molecules for transport through the microneedles **224** flow through one or more slots **228** positioned at the end of the slotted holder **226**. The device also includes a fitting portion **230** which is integral with or attached to the slotted holder **226**. The fitting portion **230** can be, for example, a female Luer lock for attachment to a conventional syringe. The use of a linear array such as in this device readily deforms the skin at a sharp radius over the tips of the microneedles **224**, greatly facilitating their penetration into the skin.

[0094] In a variation of this embodiment, several linear arrays of microneedles can be combined onto a single fitting portion or holder in order to increase the area of injection. By spacing the arrays on the holder widely enough, the correct skin deformation can be maintained. The spacing is selected to be sufficient to allow the skin or other barrier to reach a relaxed state in the region between the arrays, thus facilitating the correct deformation over each needle array in a manner independent of other arrays.

[0095] These microneedle devices are fabricated using or adapting the same microfabrication techniques described

herein. In one embodiment, microneedle arrays can be fabricated on flexible substrates, which then are mounted onto rigid spherical, cylindrical, or elliptical surfaces.

[0096] iv. Flexible Substrates

[0097] The substrate also can be flexible so that it deforms with the skin or other barrier upon application of the microneedle array.

[0098] FIGS. 18a-b illustrate a preferred embodiment of a microneedle device having a flexible substrate. In this case, device 250 include microneedles 252, which are fabricated on a flexible substrate 254. The substrate is laminated to a preformed membrane bubble 256, such as those which are used as a membrane switch. This laminated structure is attached to holder 258.

[0099] The molecules to be delivered, e.g., drug, are contained in a chamber 260 formed between the membrane bubble 256 and the substrate 254. The molecules are sealed inside the chamber either at the laminating step or are filled after lamination, for example, by injection through the membrane. A sponge or similar device (not shown) may be incorporated into the chamber 260 to contain the molecules before insertion and delivery. The sponge device is compressed by the bubble membrane as it turns to its downward position (see FIG. 18b).

[0100] In operation, the device 250 is pressed against the skin, wherein the holder 258 positions the microneedles 252 against the skin, as shown in FIG. 18a. Then, force is applied to the membrane bubble 256, flipping it through its transition state to the down position. This action applies pressure to the molecules in the chamber 260, expanding the substrate 254 of the microneedle array and pushing the microneedles 252 through the skin. Subsequently, the pressure forces the molecules through the microneedles 252 and into the skin. The change in pressure upon the membrane bubble must occur faster and be larger than can be relieved by the flow of molecules through the microneedles, in order to achieve effective delivery.

[0101] In an alternative embodiment, the chamber 260 may include an intermediate septum or equivalent divider (not shown) which can be ruptured or moved to permit the molecules to flow through the microneedles 252. For example, the user applies pressure to the membrane bubble, which pressure first forces the microneedles into the skin, as shown in FIG. 18b, and then ruptures the septum to deliver drugs through the needle and into the skin.

[0102] v. High Velocity Insertion

[0103] In another embodiment, the microneedles are applied to the skin surface at an increased velocity, thereby reducing the time available for the stratum corneum and underlying tissues to deform from contact with the tips of the microneedles. The insertion can be by forcing the microneedles into the skin, forcing the skin into the microneedles, or a combination thereof. This more rapid microneedle/skin contact can occur, for example, by releasing a compressed spring or other elastic device that pushes or pulls the microneedles, or by a rapid burst release of compressed gas against the back of the substrate. Alternatively, the skin could be forced by rapidly pulling a vacuum or pushing the skin from the sides (pinching) at the site of microneedle administration to cause the skin to be pulled up against an

array of microneedles. Various combinations of these mechanisms can be used together. The mechanisms typically are integrated into the microneedle device.

[0104] vi. Limiting Biological Barrier Elasticity

[0105] In preferred embodiments for limiting the elasticity/deformation of tissue, the microneedle device includes features suitable for stretching, pulling, or pinching the tissue, particularly skin, to present a more rigid surface in the area to which the microneedles are applied (i.e. penetrate) as illustrated in FIGS. 12a-c.

[0106] It may also be useful to cool the stratum corneum to reduce its elasticity and/or to apply chemicals to the skin surface to "tighten" the skin and reduce its elasticity. For example, the skin surface may be cooled by directing a flow of cold gas through the microneedles onto the skin surface. The flow of cold gas can be generated, for example, from a liquefied gas source such as nitrogen, carbon dioxide, or a refrigerant such as FREON™. The skin also can be cooled by contact with a cooling (e.g., refrigerated) element, such as a plate, or the microneedles themselves can function as the cooling element. The cooling element should provide sufficient local cooling of the stratum corneum so as to stiffen the stratum corneum in the vicinity of each needle sufficiently to enhance penetration. These cooling means can be used independently or in combination with chemical means to tighten the skin. Examples of chemical means include biocompatible organic solvents, such as isopropanol or acetone, which tend to dry out and stiffen the skin surface, or such astringent chemicals that can be topically applied to the skin before microneedle insertion.

[0107] a. Suction

[0108] Suction can be used to hold the skin in place during the insertion of the microneedle, limiting the deflection and deformation of skin in contact with the tips of the microneedles. Suction also can be used to bring skin in contact with stationary microneedles, and if sufficiently great, can cause the skin to be pierced by the microneedles. The suction may also enhance systemic delivery of drug by increasing blood flow in the area of administration via the microneedles, or may enhance withdrawal of interstitial fluid or blood for analysis/sensing. The suction typically is induced by creating a vacuum on the skin at the site of microneedle application. The vacuum induced is between about 10 and 2000 mm Hg, preferably between about 50 and 300 mm Hg, at the site of application. The suction typically can occur before, simultaneously with, or following insertion of the microneedles.

[0109] Examples of microneedle devices adapted to create a vacuum are shown in FIGS. 13a-c. FIG. 13a shows device 120 which includes substrate 122, microneedle array 124, and reservoir 126, which is partially enclosed by outer chamber 128. Outer chamber 128 includes a port 127 through which air or other fluids within the chamber are withdrawn following, and/or before, contact of the opening rim 129 to the skin surface. The outer chamber 128 can be made of flexible or rigid material, and generally is gas impermeable. A source of vacuum, e.g., a vacuum pump, typically is adapted to be in fluid communication with port 127. A micro-battery-powered vacuum pump can be integrated into the device to provide this function. In another embodiment, device 128 can be evacuated, so that when

triggered, the skin at the site of administration is exposed to the vacuum and is pulled up into the device. This embodiment effects a short pulse of vacuum, without requiring extra equipment. In another embodiment, a tool can be used to mechanically create the necessary vacuum upon manual activation.

[0110] FIG. 13b is a variation of the device shown in FIG. 13a, wherein device 130 includes two coaxial cylinders, outer cylinder 132 and inner cylinder 134. Vacuum is induced in the space between the cylinders. Inner cylinder 134 terminates with reservoir 136, substrate 138, and microneedles 140. Outer cylinder 132 and its rim 139 function as the outer chamber 128 and opening rim 129 in FIG. 13a. Optionally, an overpressure can be applied in the inner cylinder 134 to facilitate flow, e.g. of drug, from reservoir 136 through the microneedles 140. The device can be designed to have the inner cylinder 134 and microneedles 140 in a position fixed or movable with respect to the outer cylinder 132, as appropriate. In other embodiments, the device can have a non-cylindrical shape.

[0111] A preferred embodiment of a suction device for use with a microneedle array is shown in FIG. 13c. The suction device 200 includes body portion 202 having an inner vacuum ring 204 and an outer vacuum ring 206, separated by a ring-shaped microneedle array (not shown). The use of coaxial suction rings provides a uniform deformation force on the skin. The amount of deformation can be controlled by varying the absolute and relative sizes of the annular vacuum rings, and by controlling the amount of vacuum pulled, for example, by a suction pump. The relative height of the inner and outer rings, and their height relative to the microneedle array, can be varied to change the skin deformation and consequent pressure onto the microneedle array. In the device shown, molecules, typically as a fluid, are delivered through a port 208 in the annular ring holding the microneedles, and to the whole ring-shaped array through a circular fluidics channel 210 adjacent the substrate of the microneedles. The device shown includes a female Luer lock 212 for attachment to a conventional syringe, as well as tubing section 214 that can be used to connect the device to a vacuum pump of some kind, either manually or power driven.

[0112] b. Stretching

[0113] Stretching can also be used to limit the deflection and deformation of skin in contact with the tips of the microneedles. The stretching can be effected by a separate device or incorporated as a feature of the microneedle device itself.

[0114] FIGS. 14a-b shows one embodiment of a microneedle device that includes a stretching component. Microneedle device 150 includes flexible stretching cone 152, which includes circular outer rim 156 and surrounds microneedles 154. FIG. 14a shows device 150 with the stretching cone 152 in its normal, relaxed form and shape (i.e. no net forces applied to it) resting on the skin surface, with the tips of microneedles 154 terminating inside stretching cone 152. FIG. 14b shows device 150 following application of pressure (e.g., manual pressure) on device 150 toward the skin. As the force is applied, outer rim 156 begins to "flatten" and frictionally engages the skin surface, stretching the skin away from and perpendicular to the central axis of the stretching cone 152, while the microneedles 154 move into

contact with and then penetrate the skin. The outer rim 156 should be roughened, knurled, have teeth, or be formed of or coated with a sticky or non-slippery material so as to provide the necessary engagement between the surfaces. Examples of suitable materials include rubbers and synthetic polymers.

[0115] In another embodiment, the device includes an aperture or other means of allowing gas trapped between the barrier and the device to escape. Examples of such apertures include one or more vent holes or slits, for example, through the side of the stretching cone 152.

[0116] A preferred embodiment is shown in FIG. 14c, wherein stretching cone 152 is replaced with a plurality of, e.g., four, hinged stretching elements 153. The stretching elements stretch the skin laterally as device 150 is pressed down against the skin. The skin deflection is determined by the length of the stretcher element 153 relative to the length of the central cylinder 155. Like outer rim 156, the ends of the stretching elements 153 (distal the hinge end) preferably are roughened or knurled, have teeth, or are formed of or coated with a sticky or non-slippery material so as to control the friction between the skin and the stretching elements 153, thereby providing an additional means of controlling the stretching force. The device shown in FIG. 14c is connected to a standard female Luer lock 157, for attachment to a standard syringe. In a preferred embodiment, microneedles 154 are aligned in columns and rows substantially parallel to the stretching element 153, so as to optimize the stretching force for effective microneedle penetration.

[0117] In another embodiment, stretching of the skin is accomplished using a separate ring device, which can be pressed against the skin and then concentrically expanded to stretch the skin within the ring. For example, the ring device can be a rubber-coated metal band (having diameter x), which is compressed into a coil (having a diameter less than x). The coiled ring is then pressed against the skin and allowed to uncoil (i.e. expand to diameter x again), while frictionally engaging the skin, thereby stretching it. In a further embodiment, the ring device is configured as an iris that expands to stretch the skin upon mechanical actuation by engaging an actuation lever or rotary motion.

[0118] c. Pinching

[0119] Pinching can also be used to limit the deflection and deformation of skin in contact with the tips of the microneedles. In a preferred embodiment, the microneedle device includes jaws, typically one or more pair, which can be pressed against the skin surface and triggered to close against a segment of skin, as illustrated in FIGS. 15a-b. The size of the jaw opening can be selected based on the area of skin to be pinched to facilitate penetration of the microneedle array selected for use.

[0120] In FIGS. 15a-b, microneedle device 160 includes a pair of jaws 164 having flex or hinge points 168 and tips 166, positioned around microneedles 162. FIG. 15a shows the jaws 164 in the open position, and FIG. 15b shows the jaws 164 in the closed position, pinching an area of skin which is drawn against the microneedle 162, causing the microneedles to penetrate the skin.

[0121] An alternative embodiment of the clamping device and method is illustrated in FIG. 15c. In this embodiment, a clamping device 170 is used to pinch the skin and provide a rigid support 172 behind a pinched section of skin, in order

to present a surface of limited deformability for insertion of the microneedles 174. The clamping device 170 can be a separate device from the microneedle device 176, or the devices can be integrated into a single unit.

[0122] d. Adhesive Film Assist

[0123] The deformation of skin can be reduced by applying a thin, adhesive film over the skin surface at the site of application. The film keeps the skin taut and limits deformation at the site of microneedle insertion as the microneedles are pushed through the film and into the skin. This is analogous to the use of a surgical tape that is applied to the skin before making a surgical incision.

[0124] The adhesive film can include an expandable or shrinkable material that is triggered to change size or shape prior to microneedle application, so as to stretch the skin thereby further limiting its deformability. For example, the material can be water-swellaible, and wetted (triggering event) prior to microneedle application. In another example, the material can change form in response to a change in temperature (triggering event).

[0125] The adhesive film must be thin enough for the microneedles to penetrate both the film and the stratum corneum. If hollow microneedles are used, then the film should fracture upon penetration without substantial clogging of the hollow bore of the microneedles. Alternatively, the film could be formed of a woven or porous material so that the microneedles substantially penetrate gaps or pores in the adhesive film rather than the fibers or matrix of the film material. Examples of suitable films include ethylene-tetrafluoroethylene (ETFE) copolymer mesh (available from Goodfellow PLC) and porous films such as GORETEX™ (available from William H. Gore, Inc.) coupled with an appropriate acrylic adhesive.

[0126] vii. Creating Holes for the Microneedles

[0127] Another method of improving the penetration of biological barriers with microneedles involves producing holes or pathways in the barrier through which the microneedles can traverse, other than the pathway created solely by forcing the microneedle into barrier. A variety of techniques can be adapted for use with the microneedle devices described herein. For example, U.S. Pat. No. 5,885,211 to Eppstein, et al. discloses several methods of selectively removing the stratum corneum to enhance permeability of human skin. Some of these so-called microporation techniques disclosed can be adapted to promote penetration of microneedles into the viable epidermis. In a preferred embodiment, holes are created by vaporizing the stratum corneum, for example, by using a laser or by heating of the tips of the microneedles.

[0128] Laser techniques are described, for example, in U.S. Pat. No. 5,885,211 to Eppstein, et al. and U.S. Pat. No. 4,775,361 to Jacques et al. The laser, or pulsed light source, preferably is used in conjunction with a dye which substantially absorbs over the emission range of the light. The dye is applied to the skin and the laser or light is focused on the dye, heating it. Then, the stratum corneum adjacent to the dye is heated by conduction, elevating the temperature of tissue-bound water and other vaporizable substances in the selected area above the vaporization point of the water and other vaporizable substances. This vaporization results in degradation of the stratum corneum at one or more select,

i.e. pinpoint, areas, through which the microneedles can readily penetrate. One of skill in the art can readily select the appropriate dye, laser (e.g., Helium-Neon) or light source, and parameters of use, based, in part, on the particular microneedle array, drug to be delivered, and/or analyte to sample. In one embodiment, the light is focused, in part, by passing the light through the internal bore of a hollow microneedle.

[0129] Thermal ablation of the stratum corneum can be achieved by radiant heating (using a light/laser as described above) or by using conductive heating. For example, U.S. Pat. No. 5,885,211 to Eppstein, et al. describes contacting human skin with a heat source (conductive heating) ablate the stratum corneum. The microneedle devices described herein can be applied to the ablated skin and/or can be configured to provide the ablation of the stratum corneum, in particularly by heating the microneedles to serve as the heat source which contacts the skin. Heating of the microneedles can be accomplished, for example, by (1) contacting the needles with an ohmic heating element, (2) providing microneedles formed of or coated with a conductive material, through which a modulated electrical current is passed to induce resistive heating of the microneedles, or (3) providing microneedles positioned in a modulatable alternating magnetic field of an excitation coil such that energizing the excitation coil with alternating current produces eddy currents sufficient to heat the microneedles by internal ohmic losses. The microneedles should be able to rapidly heat the skin surface at select spots to above 100° C., preferably above 123° C., to induce flash vaporization of the water content of the stratum corneum, as described in U.S. Pat. No. 4,775,361 to Jacques et al. The heating preferably is done using an on/off cycling technique and/or adjacent cooling to minimize damage to tissues adjacent the target area. In embodiments in which the microneedles are heated, the substrate preferably includes an insulating material, as shown in **FIG. 16**, which illustrates two hollow microneedles and substrate in cross-section.

[0130] Other embodiments include applying a jet or focused blast of high pressure fluid to hydraulically puncture the stratum corneum and form a micropore into which the microneedle is inserted. The micropore preferably is slightly larger than the diameter of the microneedle. The microneedle device can be designed to utilize hollow microneedles to direct the jet of high pressure fluid. Various devices and techniques for high velocity introduction of fluids and particles into skin for delivery of drugs or genes are described, for example, in U.S. Pat. No. 5,919,159 and U.S. Pat. No. 5,599,302 to Lilley, et al. (Medi-Ject, Inc.), U.S. Pat. No. 5,899,880 to Bellhouse, et al. (PowderJect Research Ltd.), and U.S. Pat. No. 5,865,796 to McCabe (PowderJect Vaccines, Inc.).

[0131] Creation of the holes and penetration can be enhanced by select cooling/freezing of the surface of the skin, e.g., cryoablation (see U.S. Pat. No. 5,147,355 to Friedman, et al.). For example, the microneedle device can be adapted to create a local Joule-Thompson effect (see U.S. Pat. No. 5,758,505 to Dobak III, et al.).

[0132] In another embodiment, chemical agents, such as certain keratin reducing agents (see U.S. Pat. No. 5,911,223 to Weaver et al.), can be applied at the site of administration to degrade the keratin of the skin's stratum corneum, ren-

dering it more porous. Examples of suitable chemicals include sodium thiosulfate and urea.

[0133] viii. Lubricated Microneedles

[0134] In one embodiment, the microneedles include a lubricating material, such as TEFLON™ (polytetrafluoroethylene), coated onto the microneedles. In a preferred embodiment, the lubricating material is incorporated into metal microneedles, for example, by plating the lubricating material with the metal during the manufacture of the microneedles.

[0135] ix. Vibrating the Microneedles

[0136] Essentially all of the microneedle devices and methods described herein can be adapted to vibrate the microneedles and/or the skin to further facilitate penetration. The vibration can be effected to move the microneedles perpendicular and/or parallel to the surface of the biological barrier, and/or at an orientation therebetween. The vibration motion can be induced using known techniques, the most common of which is coupling the microneedle or array thereof to a piezoelectric transducer that can provide the vibratory motion. Such a transducer can be bonded directly to the array or can be bonded to a reservoir, thereby utilizing the acoustic transmission properties of the reservoir contents (e.g., an aqueous drug solution) to transmit vibration to the microneedles. Alternatively, electromechanical actuation can be used to vibrate the microneedles, such electromechanical actuation means include miniature motors and speaker coils.

[0137] 3. Methods of making Microneedle Devices

[0138] The microneedle devices are made by microfabrication processes, by creating small mechanical structures in silicon, metal, polymer, and other materials. These microfabrication processes are based on well-established methods used to make integrated circuits, electronic packages and other microelectronic devices, augmented by additional methods used in the field of micromachining. The microneedle devices can have dimensions as small as a few nanometers and can be mass-produced at low per-unit costs.

[0139] a. Microfabrication Processes

[0140] Microfabrication processes that may be used in making the microneedles disclosed herein include lithography; etching techniques, such as wet chemical, dry, and photoresist removal; thermal oxidation of silicon; electroplating and electroless plating; diffusion processes, such as boron, phosphorus, arsenic, and antimony diffusion; ion implantation; film deposition, such as evaporation (filament, electron beam, flash, and shadowing and step coverage), sputtering, chemical vapor deposition (CVD), epitaxy (vapor phase, liquid phase, and molecular beam), electroplating, screen printing, lamination, stereolithography, laser machining, and laser ablation (including projection ablation). See generally Jaeger, *Introduction to Microelectronic Fabrication* (Addison-Wesley Publishing Co., Reading Mass. 1988); Runyan, et al., *Semiconductor Integrated Circuit Processing Technology* (Addison-Wesley Publishing Co., Reading Mass. 1990); *Proceedings of the IEEE Micro Electro Mechanical Systems Conference 1987-1998*; Rai-Choudhury, ed., *Handbook of Microlithography Micromachining & Microfabrication* (SPIE Optical Engineering Press, Bellingham, Wash. 1997).

[0141] The following methods are preferred for making microneedles.

[0142] i. Electrochemical Etching of Silicon

[0143] In this method, electrochemical etching of solid silicon to porous silicon is used to create extremely fine (on the order of 0.01 μm) silicon networks which can be used as piercing structures. This method uses electrolytic anodization of silicon in aqueous hydrofluoric acid, potentially in combination with light, to etch channels into the silicon. By varying the doping concentration of the silicon wafer to be etched, the electrolytic potential during etching, the incident light intensity, and the electrolyte concentration, control over the ultimate pore structure can be achieved. The material not etched (i.e. the silicon remaining) forms the microneedles. This method has been used to produce irregular needle-type structures measuring tens of nanometers in width.

[0144] ii. Plasma Etching

[0145] This process uses deep plasma etching of silicon to create microneedles with diameters on the order of 0.1 μm or larger. Needles are patterned directly using photolithography, rather than indirectly by controlling the voltage (as in electrochemical etching), thus providing greater control over the final microneedle geometry.

[0146] In this process, an appropriate masking material (e.g., metal) is deposited onto a silicon wafer substrate and patterned into dots having the diameter of the desired microneedles. The wafer is then subjected to a carefully controlled plasma based on fluorine/oxygen chemistries to etch very deep, high aspect ratio trenches into the silicon. See, e.g., Jansen, et al., "The Black Silicon Method IV: The Fabrication of Three-Dimensional Structures in Silicon with High Aspect Ratios for Scanning Probe Microscopy and Other Applications," *IEEE Proceedings of Micro Electro Mechanical Systems Conference*, pp. 88-93 (1995). Those regions protected by the metal mask remain and form the needles. This method is further described in Example 1 below.

[0147] iii. Electroplating.

[0148] In this process, a metal layer is first evaporated onto a planar substrate. A layer of photoresist is then deposited onto the metal to form a patterned mold which leaves an exposed-metal region in the shape of needles. By electroplating onto the exposed regions of the metal seed layer, the mold bounded by photoresist can be filled with electroplated material. Finally, the substrate and photoresist mold are removed, leaving the finished microneedle array. The microneedles produced by this process generally have diameters on the order of 1 μm or larger. See, e.g., Frazier, et al., "Two dimensional metallic microelectrode arrays for extracellular stimulation and recording of neurons", *IEEE Proceedings of the Micro Electro Mechanical Systems Conference*, pp. 195-200 (1993).

[0149] iv. Other Processes

[0150] Another method for forming microneedles made of silicon or other materials is to use microfabrication techniques such as photolithography, plasma etching, or laser ablation to make a mold form (A), transferring that mold form to other materials using standard mold transfer techniques, such as embossing or injection molding (B), and

reproducing the shape of the original mold form (A) using the newly-created mold (B) to yield the final microneedles (C). Alternatively, the creation of the mold form (A) could be skipped and the mold (B) could be microfabricated directly, which could then be used to create the final microneedles (C).

[0151] Another method of forming solid silicon microneedles is by using epitaxial growth on silicon substrates, as is utilized by Containerless Research, Inc. (Evanston, Ill., USA) for its products.

[0152] b. Hollow or Porous Microneedles

[0153] In a preferred embodiment, microneedles are made with pores or other pathways through which material may be transported. The following descriptions outline representative methods for fabricating either porous or hollow microneedles.

[0154] i. Porous Microneedles

[0155] Rather than having a single, well-defined hole down the length of the needle, porous needles are filled with a network of channels or pores which allow conduction of fluid or energy through the needle shaft. It has been shown that by appropriate electrochemical oxidation of silicon, pore arrays with high aspect ratios and a range of different pore size regimes can be formed; these pore regimes are defined as (1) microporous regime with average pore dimensions less than 2 nm, (2) mesoporous regime with average pore sizes of between 2 nm and 50 nm, and (3) macroporous regime with pores greater than 50 nm. The mesoporous and macroporous regimes are expected to be most useful for drug delivery. Two approaches to porous needles are generally available, either (a) the silicon wafer is first made porous and then etched as described above to form needles or (b) solid microneedles are etched and then rendered porous, for example, by means of electrochemical oxidation, such as by anodization of a silicon substrate in a hydrofluoric acid electrolyte. The size distribution of the etched porous structure is highly dependent on several variables, including doping kind and illumination conditions, as detailed in Lehmann, "Porous Silicon—A New Material for MEMS", *IEEE Proceedings of the Micro Electro Mechanical Systems Conference*, pp. 1-6 (1996). Porous polymer or metallic microneedles can be formed, for example, by micromolding a polymer containing a volatilizable or leachable material, such as a volatile salt, dispersed in the polymer or metal, and then volatilizing or leaching the dispersed material, leaving a porous polymer matrix in the shape of the microneedle.

[0156] ii. Hollow Needles

[0157] Three-dimensional arrays of hollow microneedles can be fabricated, for example, using combinations of dry etching processes (Laermer, et al., "Bosch Deep Silicon Etching: Improving Uniformity and Etch Rate for Advanced MEMS Applications," *Micro Electro Mechanical Systems*, Orlando, Fla., USA, (Jan. 17-21, 1999); Despont et al., "High-Aspect-Ratio, Ultrathick, Negative-Tone Near-UV Photoresist for MEMS", *Proc. of IEEE 10th Annual International Workshop on MEMS*, Nagoya, Japan, pp. 518-22 (Jan. 26-30, 1997)); micromold creation in lithographically-defined and/or laser ablated polymers and selective sidewall electroplating; or direct micromolding techniques using epoxy mold transfers.

[0158] One or more distinct and continuous pathways are created through the interior of microneedles. In a preferred embodiment, the microneedle has a single annular pathway along the center axis of the microneedle. This pathway can be achieved by initially chemically or physically etching the holes in the material and then etching away microneedles around the hole. Alternatively, the microneedles and their holes can be made simultaneously or holes can be etched into existing microneedles. As another option, a microneedle form or mold can be made, then coated, and then etched away, leaving only the outer coating to form a hollow microneedle. Coatings can be formed either by deposition of a film or by oxidation of the silicon microneedles to a specific thickness, followed by removal of the interior silicon. Also, holes from the backside of the wafer to the underside of the hollow needles can be created using a front-to-backside infrared alignment followed by etching from the backside of the wafer.

[0159] a. Silicon Microneedles

[0160] One method for hollow needle fabrication is to replace the solid mask used in the formation of solid needles by a mask that includes a solid shape with one or more interior regions of the solid shape removed. One example is a "donut-shaped" mask. Using this type of mask, interior regions of the needle are etched simultaneously with their side walls. Due to lateral etching of the inner side walls of the needle, this may not produce sufficiently sharp walls. In that case, two plasma etches may be used, one to form the outer walls of the microneedle (i.e., the 'standard' etch), and one to form the inner hollow core (which is an extremely anisotropic etch, such as in inductively-coupled-plasma "ICP" etch). For example, the ICP etch can be used to form the interior region of the needle followed by a second photolithography step and a standard etch to form the outer walls of the microneedle. **FIG. 1a** represents a silicon wafer **82** with a patterned photoresist layer **84** on top of the wafer **82**. The wafer **82** is anisotropically etched (**FIG. 1b**) to form a cavity **86** through its entire thickness (**FIG. 1c**). The wafer **82** is then coated with a chromium layer **88** followed by a second photoresist layer **90** patterned so as to cover the cavity **86** and form a circular mask for subsequent etching (**FIG. 1d**). The wafer **82** is then etched by a standard etch to form the outer tapered walls **92** of the microneedle (**FIG. 1e**).

[0161] Alternatively, this structure can be achieved by substituting the chromium mask used for the solid microneedles described in Example 1 by a silicon nitride layer **94** on the silicon substrate **95** covered with chromium **96**, deposited as shown in **FIG. 2a** and patterned as shown in **FIG. 2b**. Solid microneedles are then etched as described in Example 1 as shown **FIG. 2c**, the chromium **96** is stripped (**FIG. 2d**), and the silicon **95** is oxidized to form a thin layer of silicon dioxide **97** on all exposed silicon surfaces (**FIG. 2e**). The silicon nitride layer **94** prevents oxidation at the needle tip. The silicon nitride **94** is then stripped (**FIG. 2f**), leaving exposed silicon at the tip of the needle and oxide-covered silicon **97** everywhere else. The needle is then exposed to an ICP plasma which selectively etches the inner sidewalls of the silicon **95** in a highly anisotropic manner to form the interior hole of the needle (**FIG. 2g**).

[0162] Another method uses the solid silicon needles described previously as 'forms' around which the actual

needle structures are deposited. After deposition, the forms are etched away, yielding the hollow structures. Silica needles or metal needles can be formed using different methods. Silica needles can be formed by creating needle structures similar to the ICP needles described above prior to the oxidation described above. The wafers are then oxidized to a controlled thickness, forming a layer on the shaft of the needle form which will eventually become the hollow microneedle. The silicon nitride is then stripped and the silicon core selectively etched away (e.g., in a wet alkaline solution) to form a hollow silica microneedle.

[0163] In a preferred embodiment, an array of hollow silicon microtubes is made using deep reactive ion etching combined with a modified black silicon process in a conventional reactive ion etcher, as described in Example 3 below. First, arrays of circular holes are patterned through photoresist into SiO_2 , such as on a silicon wafer. Then the silicon can be etched using deep reactive ion etching (DRIE) in an inductively coupled plasma (ICP) reactor to etch deep vertical holes. The photoresist was then removed. Next, a second photolithography step patterns the remaining SiO_2 layer into circles concentric to the holes, leaving ring shaped oxide masks surrounding the holes. The photoresist is then removed and the silicon wafer again deep silicon etched, such that the holes are etched completely through the wafer (inside the SiO_2 ring) and simultaneously the silicon is etched around the SiO_2 ring leaving a cylinder.

[0164] This latter process can be varied to produce hollow, tapered microneedles. After an array of holes is fabricated as described above, the photoresist and SiO_2 layers are replaced with conformal DC sputtered chromium rings. The second ICP etch is replaced with a SF_6/O_2 plasma etch in a reactive ion etcher (RIE), which results in positively sloping outer sidewalls. Henry, et al., "Micromachined Needles for the Transdermal Delivery of Drugs," *Micro Electro Mechanical Systems*, Heidelberg, Germany, pp. 494-98 (Jan. 26-29, 1998).

[0165] b. Metal Microneedles

[0166] Metal needles can be formed by physical vapor deposition of appropriate metal layers on solid needle forms, which can be made of silicon using the techniques described above, or which can be formed using other standard mold techniques such as embossing or injection molding. The metals are selectively removed from the tips of the needles using electropolishing techniques, in which an applied anodic potential in an electrolytic solution will cause dissolution of metals more rapidly at sharp points, due to concentration of electric field lines at the sharp points. Once the underlying silicon needle forms have been exposed at the tips, the silicon is selectively etched away to form hollow metallic needle structures. This process could also be used to make hollow needles made from other materials by depositing a material other than metal on the needle forms and following the procedure described above.

[0167] A preferred method of fabricating hollow metal microneedles utilizes micromold plating techniques, which are described as follows and in Examples 4 and 5. In a method for making metal microtubes, which does not require dry silicon etching, a photo-defined mold first is first produced, for example, by spin casting a thick layer, typically $150\ \mu\text{m}$, of an epoxy (e.g., SU-8) onto a substrate that has been coated with a thin sacrificial layer, typically about

10 to 50 nm. Arrays of cylindrical holes are then photolithographically defined through the epoxy layer, which typically is about $150\ \mu\text{m}$ thick. (Despont, et al., "High-Aspect-Ratio, Ultrathick, Negative-Tone Near-UV Photoresist for MEMS," *Proc. of IEEE 10th Annual International Workshop on MEMS*, Nagoya, Japan, pp. 518-522 (Jan. 26-30, 1997)). The diameter of these cylindrical holes defines the outer diameter of the tubes. The upper surface of the substrate, the sacrificial layer, is then partially removed at the bottom of the cylindrical holes in the photoresist. The exact method chosen depends on the choice of substrate. For example, the process has been successfully performed on silicon and glass substrates (in which the upper surface is etched using isotropic wet or dry etching techniques) and copper-clad printed wiring board substrates. In the latter case, the copper laminate is selectively removed using wet etching. Then a seed layer, such as Ti/Cu/Ti (e.g., 30 nm/200 nm/30 nm), is conformally DC sputter-deposited onto the upper surface of the epoxy mold and onto the sidewalls of the cylindrical holes. The seed layer should be electrically isolated from the substrate. Subsequently, one or more electroplatable metals or alloys are electroplated onto the seed layer. Representative suitable metals and alloys include Ni, NiFe, Au, Cu, Cr, Pt, Pd, and Ti. The surrounding epoxy is then removed, leaving microtubes which each have an interior annular hole that extends through the base metal supporting the tubes. The rate and duration of electroplating is controlled in order to define the wall thickness and inner diameter of the microtubes. In one embodiment, this method was used to produce microtubes having a height of between about 150 and $250\ \mu\text{m}$, an outer diameter of between about 40 and $120\ \mu\text{m}$, and an inner diameter of between about 30 and $110\ \mu\text{m}$ (i.e., having a wall thickness of $10\ \mu\text{m}$). In a typical array, the microtubes have a tube center-to-center spacing of about $150\ \mu\text{m}$, but can vary depending on the desired needle density.

[0168] A variation of this method is preferred for forming tapered microneedles. As described above, photolithography yields holes in the epoxy which have vertical sidewalls, such that the resulting shafts of the microneedles are straight, not tapered. This vertical sidewall limitation can be overcome by molding a preexisting 3D structure, i.e., a mold-insert. The subsequent removal of the mold-insert leaves a mold which can be surface plated similarly to the holes produced by photolithography described above.

[0169] Alternatively, non-vertical sidewalls can be produced directly in the polymeric mold into which electroplating will take place. For example, conventional photoresists known in the art can be exposed and developed in such a way as to have the surface immediately adjacent to the mask be wider than the other surface. Specialized greyscale photoresists in combination with greyscale masks can accomplish the same effect. Laser-ablated molds can also be made with tapered sidewalls, e.g., by optical adjustment of the beam (in the case of serial hole fabrication) or of the reticle or mold during ablation (in the case of projection ablation).

[0170] To form hollow tapered microneedles, the mold-insert is an array of solid silicon microneedles, formed as described in Henry, et al., "Micromachined Needles for the Transdermal Delivery of Drugs," *Micro Electro Mechanical Systems*, Heidelberg, Germany, January 26-29, pp. 494-498 (1998). First, a layer of a material, such as an epoxy (e.g.,

SU-8 or a polydimethylsiloxane ("PDMS"), is spin cast onto the array of silicon microneedles to completely blanket the entire array. The epoxy settles during pre-bake to create a planar surface above the silicon needle tips; the material is then fully pre-baked, photolithographically cross-linked, and post-baked.

[0171] The upper surface of the epoxy is then etched away, for example with an O_2/CHF_3 plasma, until the needle tips are exposed, preferably leaving between about 1 and 5 μm of tip protruding from the epoxy. The silicon is then selectively removed, for example by using a SF_6 plasma or a HNO_3/HF solution. The remaining epoxy micromold is the negative of the microneedles and has a small diameter hole where the tip of the microneedle formerly protruded.

[0172] After the removal of the silicon, a seed layer, such as Ti—Cu—Ti, is conformally sputter-deposited onto the epoxy micromold. Following the same process sequence described for hollow metal microtubes, one or more electroplatable metals or alloys, such as Ni, NiFe, Au, or Cu, are electroplated onto the seed layer. Finally, the epoxy is removed, for example by using an O_2/CHF_3 plasma, leaving an array of hollow metal microneedles. An advantage of using PDMS in this application is that the micromold can be physically removed from the silicon mold insert by mechanical means, such as peeling, without damaging the silicon mold insert, thus allowing the silicon mold insert to be reused. Furthermore, the electroplated microneedles can be removed from the PDMS mold by mechanical means, for example by peeling, thereby allowing the PDMS to also be reused. In a preferred embodiment, this method is used to produce microneedles having a height of between about 150 and 250 μm , an outer diameter of between about 40 and 120 μm , and an inner diameter of between about 50 and 100 μm . In a typical array, the microtubes have a tube center-to-center spacing of about 150 μm , but can vary depending on the desired needle density. The microneedles are 150 μm in height with a base diameter of 80 μm , a tip diameter of 10 μm , and a needle-to-needle spacing of 150 μm .

[0173] c. Silicon Dioxide Microneedles

[0174] Hollow microneedles formed of silicon dioxide can be made by oxidizing the surface of the silicon microneedle forms (as described above), rather than depositing a metal and then etching away the solid needle forms to leave the hollow silicon dioxide structures. This method is illustrated in FIGS. 3a-d. FIG. 3a shows an array 24 of needle forms 26 with masks 28 on their tips. In FIG. 3b, the needle forms 26 have been coated with a layer 30 of metal, silicon dioxide or other material. FIG. 3c shows the coated needle forms 26 with the masks 28 removed. Finally, in FIG. 3d, the needle forms 26 have been etched away, leaving hollow needles 30 made of metal, silicon dioxide, or other materials.

[0175] In one embodiment, hollow, porous, or solid microneedles are provided with longitudinal grooves or other modifications to the exterior surface of the microneedles. Grooves, for example, should be useful in directing the flow of molecules along the outside of microneedles.

[0176] d. Polymer Microneedles

[0177] In a preferred method, polymeric microneedles are made using microfabricated molds. For example, the epoxy molds can be made as described above and injection molding techniques can be applied to form the microneedles in

the molds (Weber, et al., "Micromolding—a powerful tool for the large scale production of precise microstructures", *Proc. SPIE—International Soc. Optical Engineer.* 2879:156-67 (1996); Schiff, et al., "Fabrication of replicated high precision insert elements for micro-optical bench arrangements" *Proc. SPIE—International Soc. Optical Engineer.* 3513:122-34 (1998)). These micromolding techniques are preferred over other techniques described herein, since they can provide relatively less expensive replication, i.e. lower cost of mass production. In a preferred embodiment, the polymer is biodegradable.

[0178] Microneedles, particularly hollow ones and ones formed of relatively brittle materials, may break at the juncture of the microneedle and substrate due to mechanical stresses at the sharp angle formed there. It has been found that the integrity of such microneedles can be improved by reinforcing the base of the microneedles with an additional layer of material (e.g., silicon) applied onto the face of the substrate face adjacent the base end of the microneedles as shown in FIG. 17.

[0179] 4. Microneedle Device Applications

[0180] The device may be used for single or multiple uses for rapid transport across a biological barrier or may be left in place for longer times (e.g., hours or days) for long-term transport of molecules. Depending on the dimensions of the device, the application site, and the route in which the device is introduced into (or onto) the biological barrier, the device may be used to introduce or remove molecules at specific locations.

[0181] As discussed above, FIG. 9 shows a side elevational view of a schematic of a preferred embodiment of the microneedle device 10 in a transdermal application. The device 10 is applied to the skin such that the microneedles 12 penetrate through the stratum corneum and enter the viable epidermis so that the tip of the microneedle at least penetrates into the viable epidermis. In a preferred embodiment, drug molecules in a reservoir within the upper portion 11 flow through or around the microneedles and into the viable epidermis, where the drug molecules then diffuse into the dermis for local treatment or for transport through the body.

[0182] To control the transport of material out of or into the device through the microneedles, a variety of forces or mechanisms can be employed. These include pressure gradients, concentration gradients, electricity, ultrasound, receptor binding, heat, chemicals, and chemical reactions. Mechanical or other gates in conjunction with the forces and mechanisms described above can be used to selectively control transport of the material.

[0183] In particular embodiments, the device should be "user-friendly." For example, in some transdermal applications, affixing the device to the skin should be relatively simple, and not require special skills. This embodiment of a microneedle may include an array of microneedles attached to a housing containing drug in an internal reservoir, wherein the housing has a bioadhesive coating around the microneedles. The patient can remove a peel-away backing to expose an adhesive coating, and then press the device onto a clean part of the skin, leaving it to administer drug over the course of, for example, several days.

[0184] a. Drug Delivery

[0185] Essentially any drug or other bioactive agents can be delivered using these devices. Drugs can be proteins, enzymes, polysaccharides, polynucleotide molecules, and synthetic organic and inorganic compounds. Representative agents include anti-infectives, hormones, such as insulin, growth regulators, drugs regulating cardiac action or blood flow, and drugs for pain control. The drug can be for local treatment or for regional or systemic therapy. The following are representative examples, and disorders they are used to treat:

[0186] Calcitonin, osteoporosis; Enoxaprin, anticoagulant; Etanercept, rheumatoid arthritis; Erythropoietin, anemia; Fentanyl, postoperative and chronic pain; Filgrastin, low white blood cells from chemotherapy; Heparin, anticoagulant; Insulin, human, diabetes; Interferon Beta 1a, multiple sclerosis; Lidocaine, local anesthesia; Somatropin, growth hormone; and Sumatriptan, migraine headaches.

[0187] In this way, many drugs can be delivered at a variety of therapeutic rates. The rate can be controlled by varying a number of design factors, including the outer diameter of the microneedle, the number and size of pores or channels in each microneedle, the number of microneedles in an array, the magnitude and frequency of application of the force driving the drug through the microneedle and/or the holes created by the microneedles. For example, devices designed to deliver drug at different rates might have more microneedles for more rapid delivery and fewer microneedles for less rapid delivery. As another example, a device designed to deliver drug at a variable rate could vary the driving force (e.g., pressure gradient controlled by a pump) for transport according to a schedule which was pre-programmed or controlled by, for example, the user or his doctor. The devices can be affixed to the skin or other tissue to deliver drugs continuously or intermittently, for durations ranging from a few seconds to several hours or days.

[0188] One of skill in the art can measure the rate of drug delivery for particular microneedle devices using in vitro and in vivo methods known in the art. For example, to measure the rate of transdermal drug delivery, human cadaver skin mounted on standard diffusion chambers can be used to predict actual rates. See Hadgraft & Guy, eds., *Transdermal Drug Delivery: Developmental Issues and Research Initiatives* (Marcel Dekker, New York 1989); Bronaugh & Maibach, *Percutaneous Absorption, Mechanisms—Methodology—Drug Delivery* (Marcel Dekker, New York 1989). After filling the compartment on the dermis side of the diffusion chamber with saline, a microneedle array is inserted into the stratum corneum; a drug solution is placed in the reservoir of the microneedle device; and samples of the saline solution are taken over time and assayed to determine the rates of drug transport.

[0189] In an alternate embodiment, biodegradable or non-biodegradable microneedles can be used as the entire drug delivery device, where biodegradable microneedles are a preferred embodiment. For example, the microneedles may be formed of a biodegradable polymer containing a dispersion of an active agent for local or systemic delivery. The agent could be released over time, according to a profile determined by the composition and geometry of the microneedles, the concentration of the drug and other factors. In this way, the drug reservoir is within the matrix of one or more of the microneedles.

[0190] In another alternate embodiment, these microneedles may be purposefully sheared off from the substrate after penetrating the biological barrier. In this way, a portion of the microneedles would remain within or on the other side of the biological barrier and a portion of the microneedles and their substrate would be removed from the biological barrier. In the case of skin, this could involve inserting an array into the skin, manually or otherwise breaking off the microneedles tips and then remove the base of the microneedles. The portion of the microneedles which remains in the skin or in or across another biological barrier could then release drug over time according to a profile determined by the composition and geometry of the microneedles, the concentration of the drug and other factors. In a preferred embodiment, the microneedles are made of a biodegradable polymer. The release of drug from the biodegradable microneedle tips can be controlled by the rate of polymer degradation. Microneedle tips can release drugs for local or systemic effect, or other agents, such as perfume, insect repellent and sun block.

[0191] Microneedle shape and content can be designed to control the breakage of microneedles. For example, a notch can be introduced into microneedles either at the time of fabrication or as a subsequent step. In this way, microneedles would preferentially break at the site of the notch. Moreover, the size and shape of the portion of microneedles which break off can be controlled not only for specific drug release patterns, but also for specific interactions with cells in the body. For example, objects of a few microns in size are known to be taken up by macrophages. The portions of microneedles that break off can be controlled to be bigger or smaller than that to prevent uptake by macrophages or can be that size to promote uptake by macrophages, which can be desirable for delivery of vaccines.

[0192] b. Diagnostic Sensing of Body Fluids (Biosensors)

[0193] One embodiment of the devices described herein may be used to remove material from the body across a biological barrier, i.e. for minimally invasive diagnostic sensing. For example, fluids can be transported from interstitial fluid in a tissue into a reservoir in the upper portion of the device. The fluid can then be assayed while in the reservoir or the fluid can be removed from the reservoir to be assayed, for diagnostic or other purposes. For example, interstitial fluids can be removed from the epidermis across the stratum corneum to assay for glucose concentration, which should be useful in aiding diabetics in determining their required insulin dose. Other substances or properties that would be desirable to detect include lactate (important for athletes), oxygen, pH, alcohol, tobacco metabolites, and illegal drugs (important for both medical diagnosis and law enforcement).

[0194] The sensing device can be in or attached to one or more microneedles, or in a housing adapted to the substrate. Sensing information or signals can be transferred optically (e.g., refractive index) or electrically (e.g., measuring changes in electrical impedance, resistance, current, voltage, or combination thereof). For example, it may be useful to measure a change as a function of change in resistance of tissue to an electrical current or voltage, or a change in response to channel binding or other criteria (such as an optical change) wherein different resistances are calibrated to signal that more or less flow of drug is needed, or that delivery has been completed.

[0195] In one embodiment, one or more microneedle devices can be used for (1) withdrawal of interstitial fluid, (2) assay of the fluid, and/or (3) delivery of the appropriate amount of a therapeutic agent based on the results of the assay, either automatically or with human intervention. For example, a sensor delivery system may be combined to form, for example, a system which withdraws bodily fluid, measures its glucose content, and delivers an appropriate amount of insulin. The sensing or delivery step also can be performed using conventional techniques, which would be integrated into use of the microneedle device. For example, the microneedle device could be used to withdraw and assay glucose, and a conventional syringe and needle used to administer the insulin, or vice versa.

[0196] In an alternate embodiment, microneedles may be purposefully sheared off from the substrate after penetrating the biological barrier, as described above. The portion of the microneedles which remain within or on the other side of the biological barrier could contain one or more biosensors. For example, the sensor could change color as its output. For microneedles sheared off in the skin, this color change could be observed through the skin by visual inspection or with the aid of an optical apparatus.

[0197] The microneedles can also be used for aerosolization or delivery for example directly to a mucosal surface in the nasal or buccal regions or to the pulmonary system.

[0198] The microneedle devices disclosed herein also should be useful for controlling transport across tissues other than skin. For example, microneedles can be inserted into the eye across, for example, conjunctiva, sclera, and/or cornea, to facilitate delivery of drugs into the eye. Similarly, microneedles inserted into the eye can facilitate transport of fluid out of the eye, which may be of benefit for treatment of glaucoma. Microneedles may also be inserted into the buccal (oral), nasal, vaginal, or other accessible mucosa to facilitate transport into, out of, or across those tissues. For example, a drug may be delivered across the buccal mucosa for local treatment in the mouth or for systemic uptake and delivery. As another example, microneedle devices may be used internally within the body on, for example, the lining of the gastrointestinal tract to facilitate uptake of orally-ingested drugs or the lining of blood vessels to facilitate penetration of drugs into the vessel wall. For example, cardiovascular applications include using microneedle devices to facilitate vessel distension or immobilization, similarly to a stent, wherein the microneedles/substrate can function as a "staple-like" device to penetrate into different tissue segments and hold their relative positions for a period of time to permit tissue regeneration. This application could be particularly useful with biodegradable devices. These uses may involve invasive procedures to introduce the microneedle devices into the body or could involve swallowing, inhaling, injecting or otherwise introducing the devices in a non-invasive or minimally-invasive manner.

[0199] c. Delivery of Energy

[0200] Other than transport of drugs and biological molecules, the microneedles may be used to transmit or transfer other materials and energy forms, such as light, electricity, heat, or pressure. The microneedles, for example, could be used to direct light to specific locations within the body, in order that the light can directly act on a tissue or on an intermediary, such as light-sensitive molecules in photodynamic therapy.

[0201] The present invention will be further understood with reference to the following non-limiting examples.

EXAMPLE 1

Fabrication of Solid Silicon Microneedles

[0202] A chromium masking material was deposited onto silicon wafers and patterned into dots having a diameter approximately equal to the base of the desired microneedles. The wafers were then loaded into a reactive ion etcher and subjected to a carefully controlled plasma based on fluorine/oxygen chemistries to etch very deep, high aspect ratio valleys into the silicon. Those regions protected by the metal mask remain and form the microneedles.

[0203] <100>-oriented, prime grade, 450-550 μm thick, 10-15 $\Omega\text{-cm}$ silicon wafers (Nova Electronic Materials Inc., Richardson, Tex.) were used as the starting material. The wafers were cleaned in a solution of 5 parts by volume deionized water, 1 part 30% hydrogen peroxide, and 1 part 30% ammonium hydroxide (J. T. Baker, Phillipsburg, N.J.) at approximately 80° C. for 15 minutes, and then dried in an oven (Blue M Electric, Watertown, Wis.) at 150° C. for 10 minutes. Approximately 1000 Å of chromium (Mat-Vac Technology, Flagler Beach, Fla.) was deposited onto the wafers using a DC-sputterer (601 Sputtering System, CVC Products, Rochester, N.Y.). The chromium layer was patterned into 20 by 20 arrays of 80 μm diameter dots with 150 μm center-to-center spacing using the lithographic process described below.

[0204] A layer of photosensitive material (1827 photoresist, Shipley, Marlborough, Mass.) was deposited onto the chromium layer covering the silicon wafers. A standard lithographic mask (Telic, Santa Monica, Calif.) bearing the appropriate dot array pattern was positioned on top of the photoresist layer. The wafer and photoresist were then exposed to ultraviolet (UV) light through the mask by means of an optical mask aligner (Hybralign Series 500, Optical Associates, Inc., Milpitas, Calif.). The exposed photoresist was removed by soaking the wafers in a liquid developer (354 developer, Shipley, Marlborough, Mass.) leaving the desired dot array of photoresist on the chromium layer. Subsequently, the wafers were dipped into a chromium etchant (CR-75; Cyantec Fremont, Calif.), which etched the chromium that had been exposed during the photolithography step, leaving dot arrays of chromium (covered with photoresist) on the surface of the silicon wafer. The photoresist still present on the chromium dots formed the masks needed for fabrication of the microneedles, described below.

[0205] The microneedles were fabricated using a reactive ion etching techniques based on the Black Silicon Method developed at the University of Twente. The patterned wafers were etched in a reactive ion etcher (700 series wafer/batch Plasma Processing System, Plasma Therm, St. Petersburg, Fla.) with means for ensuring good thermal contact between the wafers and the underlying platen (Apiezon N, K. J. Lesker, Clairton, Pa.). The wafers were etched using the following gases and conditions: SF_6 (20 standard cubic centimeters per minute) and O_2 (15 standard cubic centimeters per minute) at a pressure of 150 mTorr and a power of 150 W for a run time of approximately 250 minutes. These conditions caused both deep vertical etching and slight lateral underetching. By controlling the ratio of flow rates of

the SF₆ and O₂ gases used to form the plasma, the aspect ratio of the microneedles could be adjusted. The regions protected by the chromium masks remained and formed the microneedles. Etching was allowed to proceed until the masks fell off due to underetching, resulting in an array of sharp silicon spikes.

EXAMPLE 2

Transdermal Transport Using Solid Microneedles

[0206] To determine if microfabricated microneedles could be used to enhance transdermal drug delivery, arrays of microneedles were made using a deep plasma etching technique. Their ability to penetrate human skin without breaking was tested and the resulting changes in transdermal transport were measured.

[0207] Arrays of microneedles were fabricated having extremely sharp tips (radius of curvature less than 1 μm), and are approximately 150 μm long. Because the skin surface is not flat due to dermatoglyphics and hair, the full length of these microneedles will not penetrate the skin. All experiments were performed at room temperature (23±2° C.).

[0208] The ability of the microneedles to pierce skin without breaking was then tested. Insertion of the arrays into skin required only gentle pushing. Inspection by light and electron microscopy showed that more than 95% of microneedles within an array pierced across the stratum corneum of the epidermis samples. Moreover, essentially all of the microneedles that penetrated the epidermis remained intact. On those very few which broke, only the top 5-10 μm was damaged. Microneedle arrays could also be removed without difficulty or additional damage, as well as re-inserted into skin multiple times.

[0209] To quantitatively assess the ability of microneedles to increase transdermal transport, calcein permeability of human epidermis with and without inserted microneedle arrays was measured. Calcein crosses skin very poorly under normal circumstances and therefore represents an especially difficult compound to deliver. As expected, passive permeability of calcein across unaltered skin was very low, indicating that the epidermis samples were intact.

[0210] Insertion of microneedles into skin was capable of dramatically increasing permeability to calcein. When microneedles were inserted and left embedded in the skin, calcein permeability was increased by more than 1000-fold. Insertion of microneedles for 10 s, followed by their removal, yielded an almost 10,000-fold increase. Finally, insertion of a microneedle array for 1 h, followed by its removal, increased skin permeability by about 25,000-fold. Permeabilities for skin with microneedles inserted and then removed are higher than for skin with microneedles remaining embedded probably because the microneedles themselves or the silicon plate supporting the array may block access to the microscopic holes created in the skin. Light microscopy showed that the holes which remained in the skin after microneedles were removed were approximately 1 μm in size.

[0211] To confirm in vitro experiments which showed that skin permeability can be significantly increased by microneedles, studies were conducted with human volunteers. They

indicated that microneedles could be easily inserted into the skin of the forearm or hand. Moreover, insertion of microneedle arrays was never reported to be painful, but sometimes elicited a mild "wearing" sensation described as a weak pressure or the feeling of a piece of tape affixed to the skin. Although transport experiments were not performed in vivo, skin electrical resistance was measured before and after microneedle insertion. Microneedles caused a 50-fold drop in skin resistance, a drop similar to that caused by the insertion of a 30-gauge "macroneedle." Inspection of the site immediately after microneedle insertion showed no holes visible by light microscopy. No erythema, edema, or other reaction to microneedles was observed over the hours and days which followed. This indicates that microneedle arrays can permeabilize skin in human subjects in a non-painful and safe manner.

EXAMPLE 3

Fabrication of Silicon Microtubes

[0212] Three-dimensional arrays of microtubes were fabricated from silicon, using deep reactive ion etching combined with a modified black silicon process in a conventional reactive ion etcher. The fabrication process is illustrated in FIGS. 4a-d. First, arrays of 40 μm diameter circular holes 32 were patterned through photoresist 34 into a 1 μm thick SiO₂ layer 36 on a two inch silicon wafer 38 (FIG. 4a). The wafer 38 was then etched using deep reactive ion etching (DRIE) (Laermer, et al., "Bosch Deep Silicon Etching: Improving Uniformity and Etch Rate for Advanced MEMS Applications," *Micro Electro Mechanical Systems*, Orlando, Fla., USA (Jan. 17-21, 1999)). in an inductively coupled plasma (ICP) reactor to etch deep vertical holes 40. The deep silicon etch was stopped after the holes 40 are approximately 200 μm deep into the silicon substrate 38 (FIG. 4b) and the photoresist 34 was removed. A second photolithography step patterned the remaining SiO₂ layer 36 into circles concentric to the holes, thus leaving ring shaped oxide masks 34 surrounding the holes (FIG. 4c). The photoresist 34 was then removed and the wafer 38 was again deep silicon etched, while simultaneously the holes 40 were etched completely through the wafer 38 (inside the SiO₂ ring) and the silicon was etched around the SiO₂ ring 38 leaving a cylinder 42 (FIG. 4d). The resulting tubes were 150 μm in height, with an outer diameter of 80 μm, an inner diameter of 40 μm, and a tube center-to-center spacing of 300 μm.

EXAMPLE 4

Micromold Fabrication of Metal Microtubes

[0213] Hollow metal microtubes were prepared without dry silicon etching, using a thick, photo-defined mold of epoxy. The sequences are illustrated in FIGS. 5a-e. First, a thick layer of SU-8 epoxy 44 was spin cast onto a silicon or glass substrate 46 that had been coated with 30 nm of titanium 48, the sacrificial layer. Arrays of cylindrical holes 49 were then photolithographically defined through an epoxy layer 44, typically 150 μm thick (FIG. 5a). The sacrificial layer then was partially removed using a wet etching solution containing hydrofluoric acid and water at the bottom of the cylindrical holes in the SU-8 photoresist 46 (FIG. 5b). A seed layer of Ti/Cu/Ti (30 nm/200 nm/30 nm) 39 was then conformally DC sputter-deposited onto the

upper surface of the epoxy mold and onto the sidewalls of the cylindrical holes **49** (FIG. 5c). As shown in FIG. 5c, the seed layer **39** was electrically isolated from the substrate. Subsequently, NiFe was electroplated onto the seed layer **39** (FIG. 5d), the epoxy **44** was removed from the substrate, and the surrounding epoxy **44** was removed (FIG. 5e). The resulting microtubes are 200 μm in height with an outer diameter of 80 μm , an inner diameter of 60 μm , and a tube center-to-center spacing of 150 μm . The holes in the interior of the microtubes protrude through the base metal supporting the tubes.

EXAMPLE 5

Micromold Fabrication of Tapered Microneedles

[0214] A micromold having tapered walls was fabricated by molding a preexisting 3-D array of microneedles, i.e. the mold-insert, and subsequently removing the mold insert. The micromold was then surface plated in a manner similar to that for the microtubes described in Example 4. The fabrication sequence is illustrated in FIGS. 6a-d.

[0215] First, an array of solid silicon microneedles **50** were prepared as described in Henry, et al., "Micromachined Needles for the Transdermal Delivery of Drugs," *Micro Electro Mechanical Systems*, Heidelberg, Germany, January 26-29, pp. 494-98 (1998). Then, a layer of epoxy **52** (SU-8) was spin cast onto the microneedle array to completely blanket the array (FIG. 6a). The epoxy **52** settled during pre-bake to create a planar surface above the tips of the microneedles **50**. The epoxy **52** was then fully pre-baked, photolithographically cross-linked, and post-baked.

[0216] Then, the upper surface of the epoxy **52** was etched away using an O_2/CHF_3 plasma until approximately 1 to 2 μm of the needle tips **54** were exposed, protruding from the epoxy **52** (FIG. 6b). The silicon was then selectively removed by using a SF_6 plasma (FIG. 6c). The remaining epoxy mold **52** provided a negative of the microneedles with a small diameter hole where the tip of the silicon needle protruded. After the removal of the silicon, a seed layer of Ti—Cu—Ti **54** was conformally sputter-deposited onto the top and sidewalls of the epoxy micromold **52**. Following the same process sequence as described in Example 4, NiFe was then electroplated onto the seed layer **54** (FIG. 6c). Finally, the epoxy was removed using an O_2/CHF_3 plasma, leaving a 20 \times 20 array of NiFe hollow metal microneedles **54** (FIG. 6d). The microneedles **54** were 150 μm in height with a base diameter of 80 μm , a tip diameter of 10 μm , and a needle-to-needle spacing of 150 μm .

[0217] Micromold-based microneedles also have been successfully manufactured using a process in which the epoxy mold material was replaced with PDMS. In this case, it was possible to remove the mold from the mold insert, as well as the microneedles from the mold, using only physical techniques such as peeling. This approach advantageously requires no dry etching and allows one to reuse both the mold and the mold insert.

EXAMPLE 6

Micromold Fabrication of Tapered Microneedles using Laser-Formed Molds

[0218] A micromold having tapered walls was fabricated by use of laser ablation techniques, as shown in FIGS. 7a-d.

A laser-ablatable polymer sheet **60** such as KAPTON™ polyimide approximately 150 microns in thickness was optionally laminated to a thin (10-30 micron) metal sheet **62** such as titanium (FIG. 7a). A tapered hole **64** was formed in the metal/polymer laminate **60/62** using a laser technique such as excimer laser ablation (FIG. 7b). The entry hole of the laser spot was on the metal side **62**, and a through hole was made through both the metal sheet and the polymer film. The through hole **64** was tapered in combination with either defocusing or appropriate substrate motion to create a taper such that the wide end of the hole **64** (typically 40-50 microns) was on the metal side **62** and the narrow end of the hole **64** (typically 10-20 microns) was on the polymer **60** side. A thin layer of metal **66**, e.g. titanium, of thickness 0.1 micron was then deposited, e.g., using a sputter-deposition technique, in such a way that the metal **66** deposited on the metal film side and coated the polymer sidewalls, but did not coat the polymer **60** side of the laminate (FIG. 7c). Electrodeposition of metal **68**, e.g., gold, to a thickness of 1 to 5 microns was then performed on the titanium-coated metal surface **66**, and polymer sidewalls curved section of **60** next to **64**. Finally, the polymer **60** was removed, using e.g. an oxygen plasma, to form the completed microneedles (FIG. 7d).

[0219] Alternate polymer removal methods, such as thermal, solvent, aqueous, or photo-degradation followed by solvent or aqueous removal, are also possible if the polymer material is chosen appropriately (e.g., a photoresist resin).

EXAMPLE 7

Formation of Microneedles by Embossing

[0220] Formation of a microneedle by embossing is shown in FIGS. 8a-f. A polymeric layer **70** (FIG. 8a) is embossed by a solid microneedle or microneedle array **72** (FIG. 8b). The array **72** is removed (FIG. 8c), and the layer **70** is etched from the non-embossed side **74** until the embossed cavity **76** is exposed (FIG. 8d). A metallic layer **78** is then deposited on the embossed side and the sidewalls, but not on the non-embossed side **74** (FIG. 8e). This layer **78** is optionally thickened by electrodeposition of an additional metal layer **80** on top of it (FIG. 8e). The polymer layer **70** is then removed to form the microneedles **78/80** (FIG. 8f).

EXAMPLE 8

Transdermal Application of Hollow Microneedles

[0221] The bore of hollow microneedles must provide fluid flow with minimal clogging in order to be suitable to transport material, such as in transdermal drug delivery. Therefore, microneedles and microtubes were evaluated to determine their suitability for these functions.

[0222] Hollow metal and silicon microneedles, produced as described in Examples 3-5, were inserted through human skin epidermis with no apparent clogging of the needle bores. Scanning electron microscopy of a hollow metal (NiFe) microneedle penetrating up through the underside of human epidermis showed the microneedle remains intact, with the tip free of debris. Similarly, silicon microneedles, metal microneedles, and metal microtubes were successfully inserted through human skin. Also, the hollow microneedles were shown to permit the flow of water through their bores.

EXAMPLE 9

Drug Transport Through Microneedles Inserted into Skin

[0223] Studies were performed with solid and hollow microneedles to demonstrate transport of molecules and fluids. As shown in Table 1, transport of a number of different compounds across skin is possible using microneedles. These studies were performed using either solid silicon microneedles or using hollow silicon microneedles made by methods described in this patent. Transport was measured across human cadaver epidermis in vitro using Franz diffusion chambers at 37° C. using methods described in Henry, et al., "Microfabricated microneedles: A novel method to increase transdermal drug delivery" *J. Pharm. Sci.* 87: 922-25 (1998).

[0224] The transdermal delivery of calcein, insulin, bovine serum albumin ("BSA"), and nanoparticles was measured. Delivery refers to the ability to transport these compounds from the stratum corneum side of the epidermis to the viable epidermis side. This is the direction of transport associated with delivering drugs into the body. Removal of calcein was also measured. Removal refers to the ability to transport calcein from the viable epidermis side of the epidermis to the stratum corneum side. This is the direction of transport associated with removing from the body compounds found in the body, such as glucose.

[0225] In all cases shown in Table 1, transport of these compounds across skin occurred at levels below the detection limit when no needles were inserted into the skin. Intact skin provides an excellent barrier to transport of these compounds. In all cases examined, when solid microneedles were inserted into the skin and left in place, large skin permeabilities were measured, indicating that the microneedles had created pathways for transport across the skin. Furthermore, in all cases, when solid microneedles were inserted into the skin and then removed, even greater skin permeabilities resulted. Finally, when hollow microneedles were inserted into the skin and left in place, still greater skin permeabilities resulted for those compounds tested. These studies show that microneedles can dramatically increase skin permeability and can thereby increase transport of a number of different compounds across the skin. They also shows that when solid microneedles are used, a preferred embodiment involves inserting and then removing microneedles, rather than leaving them in place. They also shows that using hollow microneedles are a preferred embodiment over the use of solid microneedles.

[0226] In Table 2, the flow rate of water through hollow silicon microneedles is shown as a function of applied pressure. These data demonstrate that significant flow rates of water through microneedles can be achieved at modest pressures.

TABLE 1

Transport of Drugs Through Microneedles Inserted Into Skin				
Compound	No needles	Solid needles inserted	Solid needles inserted and removed	Hollow needles inserted
Calcein	**	4×10^{-3}	1×10^{-2}	1×10^{-1}

TABLE 1-continued

Transport of Drugs Through Microneedles Inserted Into Skin				
Compound	No needles	Solid needles inserted	Solid needles inserted and removed	Hollow needles inserted
Calcein delivery	**	2×10^{-3}	1×10^{-2}	n.a.
Calcein removal	**	1×10^{-4}	1×10^{-2}	n.a.
Insulin delivery	**	9×10^{-4}	8×10^{-3}	9×10^{-2}
BSA delivery	**	n.a.	3×10^{-5}	n.a.
Nanoparticle delivery	**	n.a.	3×10^{-5}	n.a.

**means that the transport was below the detection limit.

n.a. means that the data are not available.

Nanoparticles were made of latex with a diameter of approximately 100 nm.

[0227]

TABLE 2

Flow Rate of Water Through Hollow Silicon Microneedles as a Function of Applied Pressure	
Pressure (psi)	Flow rate (ml/min)
1.0	16
1.5	24
2.0	31
2.5	38
3.0	45

[0228] Publications cited herein and the material for which they are cited are specifically incorporated by reference. Nothing herein is to be construed as an admission that the invention is not entitled to antedate such disclosure by virtue of prior invention.

[0229] Modifications and variations of the methods and devices described herein will be obvious to those skilled in the art from the foregoing detailed description. Such modifications and variations are intended to come within the scope of the appended claims.

1. A device for transport of material or energy across or into an elastic biological barrier comprising:

a microneedle having a tip end and a base end,

a substrate connected to the base end of the microneedle, and

a means for improving penetration of the biological barrier by the microneedle.

2. The device of claim 1 wherein the biological barrier is human or other mammalian skin.

3. The device of claim 1 wherein the means comprises one or more extensions

(i) interposed between the substrate and the base end of the microneedle, or

(ii) extending from the side of the substrate distal to the base end of the microneedle.

4. The device of claim 3 wherein the extension is between about 500 μm and about 10 mm in height.

5. The device of claim 3 wherein the extension has a cross-sectional dimension of at least about 200 μm.

6. The device of claim 3 wherein the extension includes an array of microneedles extending therefrom.

7. The device of claim 3 wherein the extension is composed of a material which is different from the material forming the microneedles.

8. The device of claim 3 wherein the microneedle is hollow and wherein the extension includes at least one aperture in communication with the bore of the microneedle.

9. The device of claim 3 further comprising a rigid surface positioned apart from an array of the microneedles and oriented to contact an elastic biological barrier substantially at the same time as the microneedles when the microneedles are applied to the barrier.

10. The device of claim 1 wherein the substrate is curved.

11. The device of claim 1 comprising a plurality of microneedles of varying lengths.

12. The device of claim 11 comprising four or more microneedles wherein the tip ends of the microneedles collectively define a curvilinear surface.

13. The device of claim 1 comprising a plurality of hollow microneedles in a linear array, wherein the substrate is mounted on a holder having one or more apertures through the holder in communication with the microneedles.

14. The device of claim 1 wherein the substrate is flexible.

15. The device of claim 14 wherein the substrate is deformable by fluid pressure or mechanical means.

16. The device of claim 15 wherein the substrate is mounted onto a flexible membrane bubble.

17. The device of claim 16 further comprising a second membrane bubble positioned to define a chamber between the flexible membrane bubble and the second membrane bubble.

18. The device of claim 17 wherein the chamber contains molecules which flow through the microneedle.

19. The device of claim 18 wherein the molecules are drug molecules.

20. The device of claim 1 wherein the means reduces the elasticity of the biological barrier.

21. The device of claim 20 wherein the means physically manipulates the biological barrier to present a more rigid surface in the area of the biological barrier to be penetrated by the microneedle.

22. The device of claim 21 wherein the manipulation is selected from the group consisting of stretching, pulling, pinching, and a combination thereof.

23. The device of claim 22 wherein the manipulation includes pulling by reducing the atmospheric pressure over the area of the biological barrier to be penetrated by the microneedles.

24. The device of claim 23 further comprising a body portion defining a first vacuum region and a second vacuum region, wherein an array of microneedles separates the first and second regions.

25. The device of claim 24 wherein the body portion comprises an annular ring which holds the microneedles.

26. The device of claim 25 wherein the microneedle is hollow and wherein the body portion further comprises a means for attachment to a syringe, a conduit for connection to a vacuum pump, or both.

27. The device of claim 22 wherein the means comprises a stretching cone or expandable ring around the microneedles.

28. The device of claim 22 wherein the means comprises a body portion from which a plurality of stretching elements are pivotally attached.

29. The device of claim 28 wherein the stretching elements have ends provided with a non-slip feature for engagement with the biological barrier.

30. The device of claim 22 wherein the means comprises jaws for pinching a portion of the biological barrier for contact with the microneedles.

31. The device of claim 21 wherein the means comprises an adhesive film applied over the area of the biological barrier to be penetrated by the microneedle.

32. The device of claim 2 wherein the means for improving penetration creates holes in the stratum corneum, wherein the microneedle can be inserted into the holes.

33. The device of claim 32 wherein the means for creating holes is selected from the group consisting of thermal ablation, high pressure fluid puncturing, cryoablation, and application of degradation agents.

34. The device of claim 1 wherein the means for improving penetration accelerates the tips of the microneedles into the biological barrier, accelerates the biological barrier into contact with the tips of the microneedles, or a combination thereof.

35. The device of claim 34 wherein the means for accelerating the tip of the microneedle comprises releasing a spring or gas under compression.

36. The device of claim 1 wherein a lubricating material is incorporated into or coated onto the microneedle.

37. The device of claim 1 further comprising a collar to limit the depth of microneedle penetration.

38. The device of claim 1 further comprising a means for attaching the device to the skin of a patient, wherein the means is not the microneedle.

39. The device of claim 38 wherein the means is an adhesive film.

40. The device of claim 38 wherein the means is an arm band.

41. The device of claim 1 wherein the microneedle is hollow and wherein the device further comprises a reservoir selectively in communication with the hollow microneedle.

42. The device of claim 1 wherein the means for enhancing penetration comprises an apparatus for vibrating the microneedle.

43. The device of claim 42 wherein the apparatus comprises a piezoelectric transducer or an electromechanical actuator.

44. A kit of parts for use in transport of material or energy across or into an elastic biological barrier, comprising

(i) a device comprising one or more microneedles having a tip end and a base end, and a substrate connected to the base end of the microneedle, and

(ii) an adhesive film or barrier-tightening chemical, either of which can be applied over an area of the biological barrier to be penetrated by the microneedle.

45. A method for transport of material or energy across or into an elastic biological barrier, comprising using the device of claim 1.