



US 20040178214A1

(19) **United States**

(12) **Patent Application Publication**
Wei

(10) **Pub. No.: US 2004/0178214 A1**

(43) **Pub. Date: Sep. 16, 2004**

(54) **BLADE DISPENSER**

Publication Classification

(76) Inventor: **Wu Yue Wei, Ningbo (CN)**

(51) **Int. Cl.7** **B65H 3/00**

(52) **U.S. Cl.** **221/247**

Correspondence Address:

THOMPSON HINE L.L.P.
2000 COURTHOUSE PLAZA, N.E.
10 WEST SECOND STREET
DAYTON, OH 45402 (US)

(57) **ABSTRACT**

A blade dispenser including a dispenser body including a cavity shaped to store a plurality of blades therein. The blade dispenser includes a pivotable plate located in or adjacent to the cavity such that the plate can receive at least one blade stored in the cavity thereon. The plate is pivotable such that a blade located thereon can be moved at least partially outside of the cavity when the plate is pivoted such that a user can access a blade located on the plate. The plate includes a magnet located thereon to magnetically interact with a blade located on the plate to maintain the blade on the plate.

(21) Appl. No.: **10/718,760**

(22) Filed: **Nov. 21, 2003**

(30) **Foreign Application Priority Data**

Mar. 8, 2003 (CN) 03227939.6

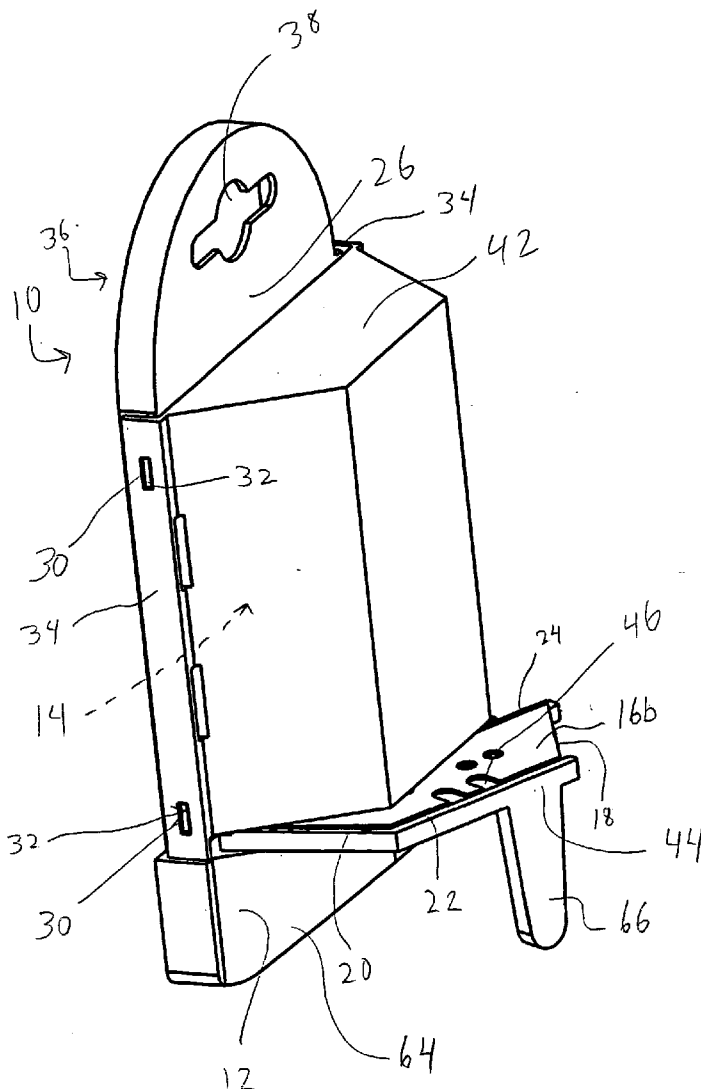

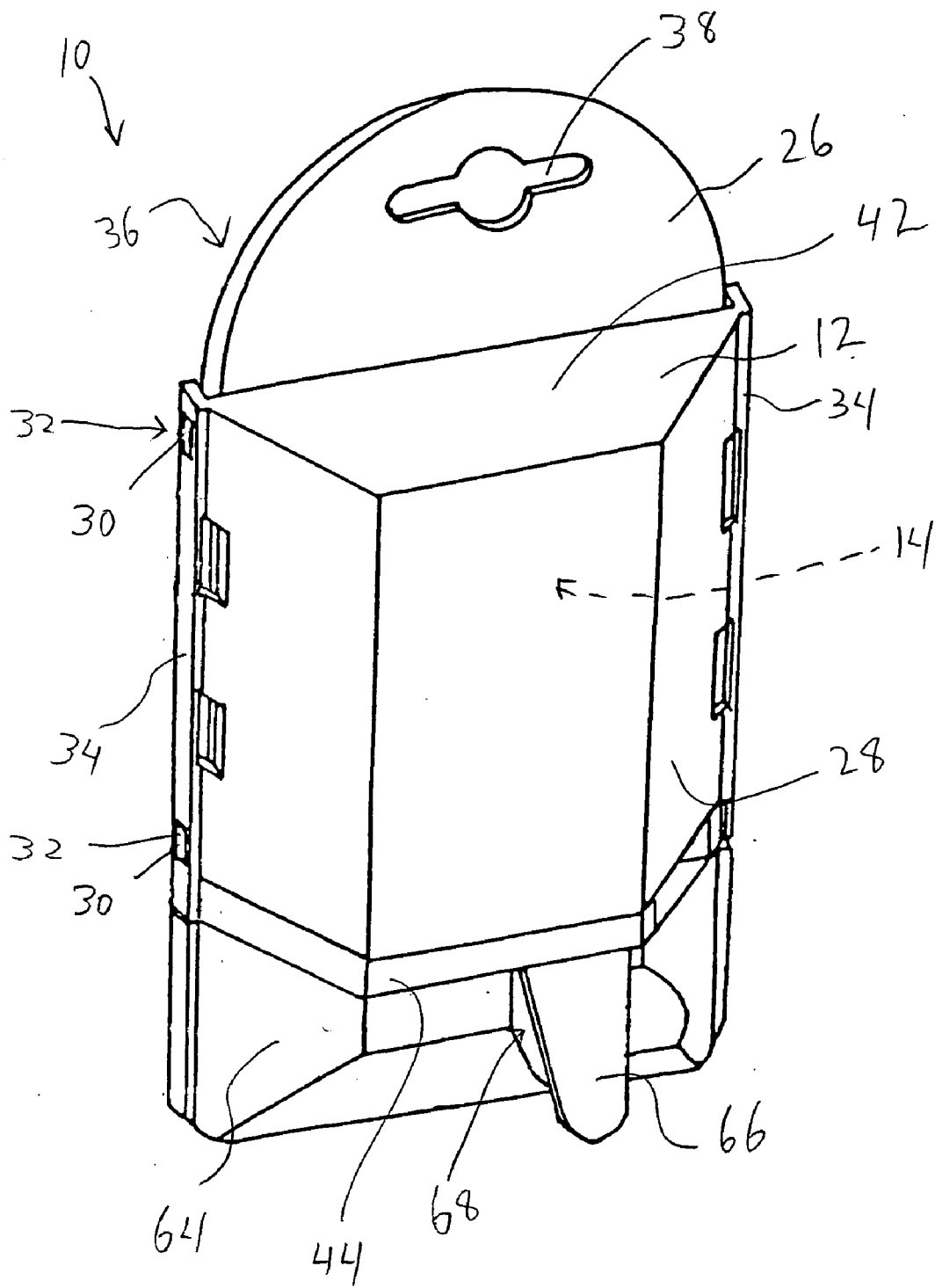

FIG. 1

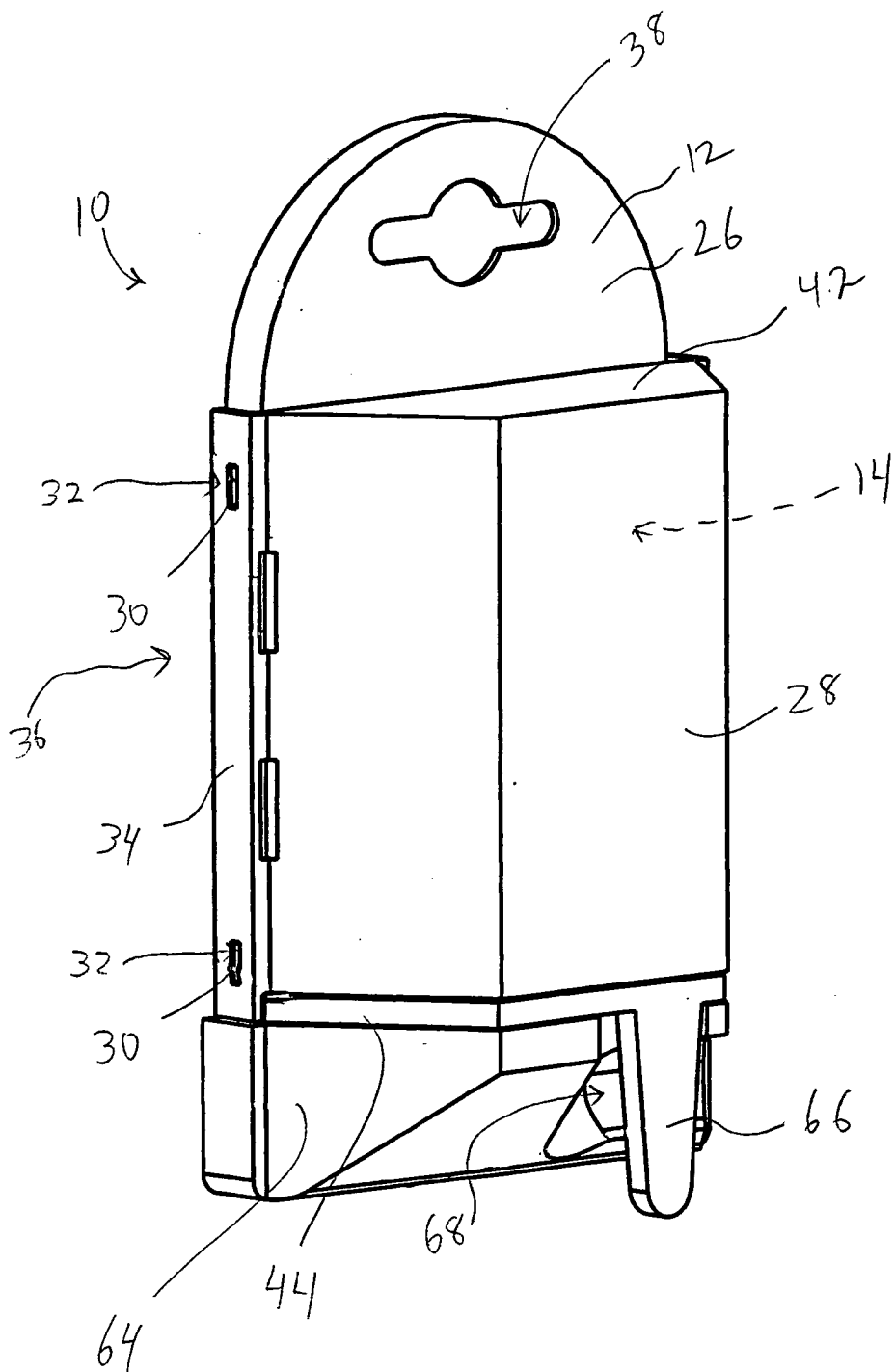

FIG. 2

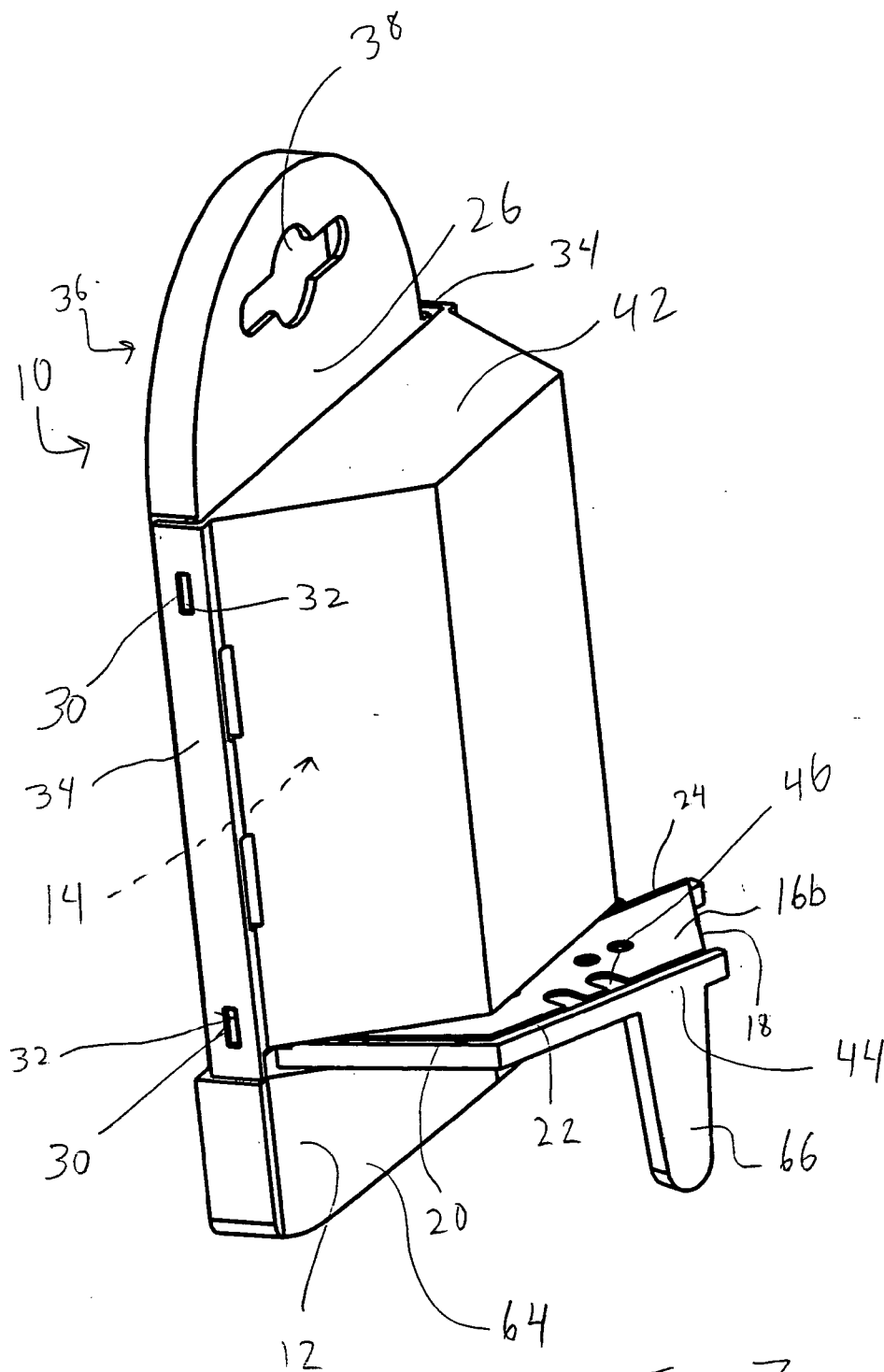
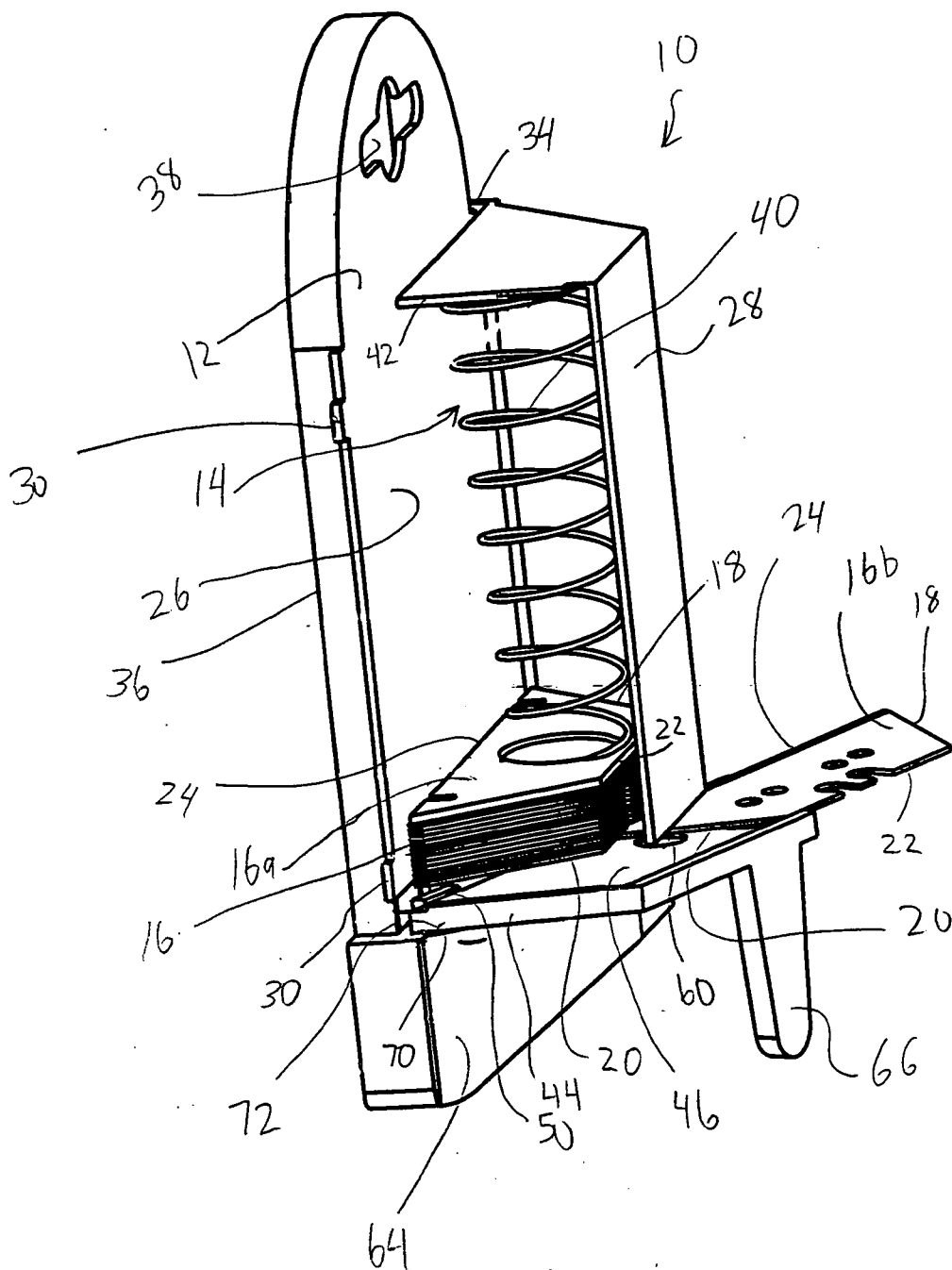

FIG. 3



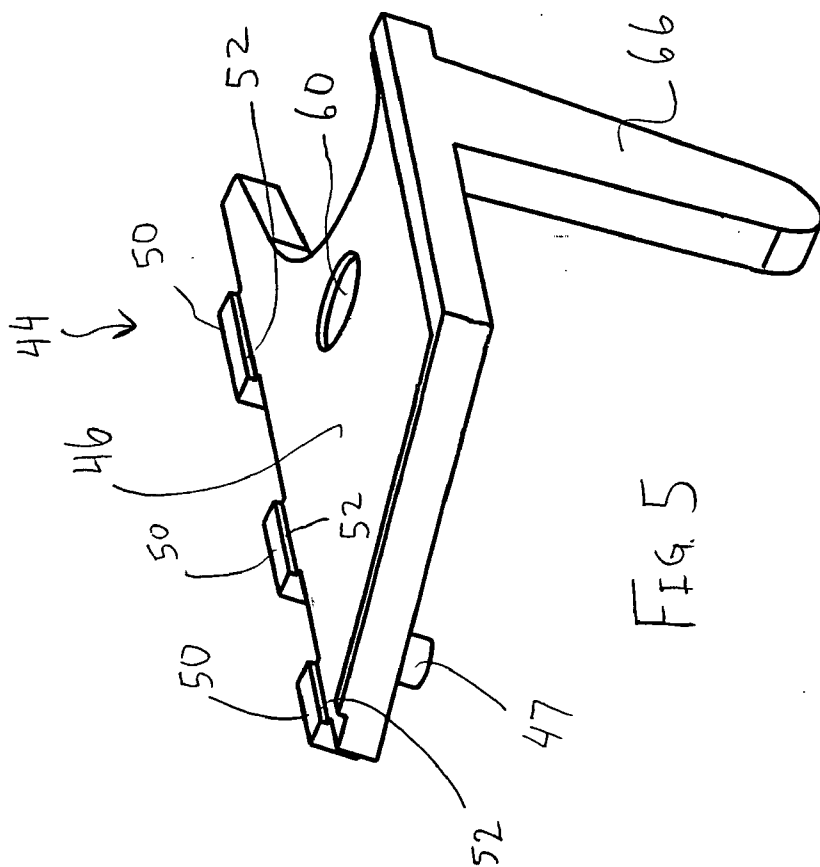

FIG. 5

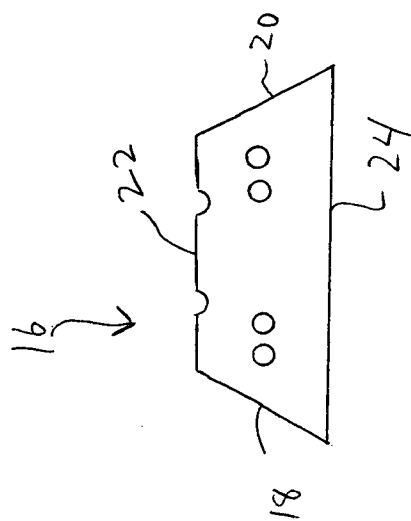

FIG. 6

BLADE DISPENSER

[0001] The present invention is directed to a blade dispenser, and more particularly, to a blade dispenser including a pivotable plate for dispensing the blades.

BACKGROUND

[0002] Bladed instruments, such as utility knives, box cutters, etc. typically include a sharp blade or knife edge to perform cutting operations. Many such cutting instruments may include replaceable blades so that new blades may replace worn blades as the cutting edge loses its sharpness, breaks, or otherwise needs replacement. Accordingly, many companies manufacture and sell replacement blades, which may be packaged inside a blade dispenser for individual dispensing of blades.

[0003] However, existing blade dispensers can be difficult to use, as it may be difficult to access and grip the blade to be dispensed. Accordingly, there is a need for an improved blade dispenser.

SUMMARY

[0004] In one embodiment the invention is a blade dispenser having a pivotable blade plate. A blade to be dispensed may rest on the pivotable plate such that a user can pivot the pivotable plate to enable the blade located on the plate to be easily accessed and gripped by a user.

[0005] In one embodiment, the invention is a blade dispenser including a dispenser body including a cavity shaped to store a plurality of blades therein. The blade dispenser includes a pivotable plate located in or adjacent to the cavity such that the plate can receive at least one blade stored in the cavity thereon. The plate is pivotable such that a blade located thereon can be moved at least partially outside of the cavity when the plate is pivoted such that a user can access a blade located on the plate. The plate includes a magnet located thereon to magnetically interact with a blade located on the plate to maintain the blade on the plate.

[0006] In another embodiment, the invention is a blade dispenser including a dispenser body including a cavity that is generally trapezoidal in cross section and shaped to generally closely receive and store a plurality of generally trapezoidal blades therein, each blade having a short straight edge and a long straight edge generally parallel to the short edge. The blade dispenser further includes a pivotable plate located in or adjacent to the cavity such that the plate can receive at least one blade of the plurality of blades stored in the cavity thereon. The plate is pivotable such that the at least one blade located thereon can be moved at least partially outside of the cavity when the plate is pivoted such that a user can access the at least one blade. The plate includes an engagement surface shaped to engage the at least one blade when the plate is pivoted to separate the one of the blades from the plurality of blades, the engagement surface being located to engage the long straight edge of the one of the blades.

[0007] In another embodiment, the invention is a blade dispenser including a dispenser body including a cavity shaped to store a plurality of blades therein. The dispenser body further includes a pivotable plate located in or adjacent to the cavity such that the plate can receive at least one blade of the plurality of blades stored in the cavity thereon. The

plate is pivotable such that a blade located thereon can be moved at least partially outside of the cavity when the plate is pivoted such that a user can access the blade located on the plate. At least one of the body or plate includes a stop surface to limit the pivoting motion of the plate.

[0008] Other objects and advantages of the present invention will be apparent from the following description and the accompanying drawings.

BRIEF DESCRIPTION OF THE DRAWINGS

[0009] FIG. 1 is a front perspective view of one embodiment of the blade dispenser of the present invention;

[0010] FIG. 2 is another front perspective view of the blade dispenser of FIG. 1;

[0011] FIG. 3 is another front perspective view of the blade dispenser of FIG. 1, illustrating the pivot plate pivoted partially outwardly;

[0012] FIG. 4 is a side perspective view of the blade dispenser of FIG. 3, with the cover partially cut away;

[0013] FIG. 5 is a front perspective view of one embodiment of the pivot plate of any of the blade dispenser of FIGS. 1-4; and

[0014] FIG. 6 is a top view of one embodiment of a blade which may be used with the blade dispenser of the FIGS. 1-4.

DETAILED DESCRIPTION

[0015] As shown in FIG. 1, in one embodiment the blade dispenser of the present invention, generally designated 10, includes a dispenser body 12 which includes a cavity 14 therein that is shaped to receive and store a plurality of blades 16 therein. As shown in FIG. 6, in one embodiment each of the blades 16 may be generally trapezoidal in top view having a long straight edge 24 and a short straight edge 22 oriented generally parallel to the long straight edge 24. In one embodiment, the long straight edge 24 may be a sharpened edge of the blade 16. Each blade may further include a pair of angled edges 18, 20, which extend between a short straight edge 22 and a long straight edge 24.

[0016] As shown in FIG. 4, in one embodiment the dispenser body 12 includes a backing plate or backing surface 26, and a cover 28 removably coupled to the backing surface 26. For example, the backing plate 26 may include a pair of ears 30 protruding generally outwardly from either side of the backing plate 26 (only one set of ears 30 being shown in FIG. 4). The cover 28 may include a pair of slots 32 formed in opposed outer edges 34 with each slot 32 corresponding to one of the ears 30.

[0017] Accordingly, as shown for example in FIG. 1, the cover 28 can be removably coupled to the backing plate or backing surface 26 by fitting each of the ears 30 of the backing surface 26 through a corresponding slot 32 of the cover 28. The cover 28 may also include a set of retaining tabs (not shown) which can fit behind the rear surface 36 of the backing plate 26 to retain the cover 28 on the backing plate 26. The cover 28 can be uncoupled from the backing plate 26 by prying the outer edges 34 of the cover 28 away from the backing plate 26 until the ears 30 are no longer

received in the slots 32 and the retaining tabs are moved outside of the backing plate 26.

[0018] The cover 28 may be generally trapezoidal in cross section such that the cavity 14 is correspondingly generally trapezoidal in cross section. In this manner, the generally trapezoidal cavity 14 can generally closely receive the blades 16 therein. The backing plate 26 may include a cutout 38 located at an upper end thereof such that the dispenser body 12 can receive a hangtag component (i.e., hanger) therethrough to display the blade dispenser 10 on a hangtag system.

[0019] As shown in FIG. 4, the cavity 14 may receive a plurality or stack of aligned blades 16 therein, wherein the blades 16 are arranged such that the long, sharp edge 24 of each blade 16 is located against the backing plate 16. The blade dispenser 10 may further include a biasing mechanism, such as in the illustrated embodiment, a spring 40 located in the cavity 14. The spring 40 is captured between a top surface 42 of the cover 28 and the top blade 16a in the stack of blades 16 to bias or urge the blades 16 downwardly. Various other biasing means, including spring arms, flexible components and the like may also be used in place of, or in conjunction with, the spring 40. Alternately, the blade dispenser 10 may rely upon gravity to pull the stack of blades downwardly.

[0020] The blade dispenser 10 may further include a pivot plate 44 located at the bottom of the cavity 14 and adjacent to the lowermost blade of the stack of blades 16. The pivot plate 44 may include a generally flat upper or seating surface 46 and a generally cylindrical stub 47 (FIG. 4) which is received in a corresponding opening of the dispenser body 12 to pivotally couple the pivot plate 44 to the dispenser body 12. As can be seen in a comparison between FIGS. 2, 3 and 4, the pivot plate 44 may be pivotable about a generally vertically extending axis (i.e., the center of the stub 47) which extends generally parallel to the backing plate 26 such that the pivot plate 44 can be pivoted away from the cavity 14. For example, when the pivot plate 44 is in its retracted or closed position (i.e., FIG. 1), the upper surface 46 of the pivot plate may be generally fully received in, or form part of, the cavity 44. When the pivot plate 44 is in its retracted position, the lowermost blade 16b of the stack of blades 16 may be urged onto the pivot plate 44 by the spring 40.

[0021] As shown in FIG. 5, the pivot plate 44 may include a set of teeth 50 on an inner surface thereof with each tooth 50 protruding slightly upwardly above the seating surface 46. Each tooth 50 can thereby define a generally vertically oriented engagement surface 52 that is oriented generally perpendicular to the seating surface 46. When a user desires to dispense a blade 16, the pivot plate 44 can be pivoted away from its retracted position to an extended position as shown, for example, in FIG. 3 or 4. As the pivot plate 44 is pivoted from its retracted to an extended position, the engagement surface 52 of each tooth 50 can engage the long surface 24 of a blade 16 to cause the lowermost blade 16b to be pulled along with the pivot plate 44 as the pivot plate 44 is pivoted about its pivot axis.

[0022] In this manner, the engagement surfaces 52 can pull or separate the lowermost blade 16b away from the stack of blades 16 to dispense the lowermost blade 16b. Thus, it can be seen that the height of the engagement

surfaces 52 may be selected to ensure that only a single blade 16 is engaged and pulled along with the pivot plate 44 as the pivot plate 44 is pivoted outwardly. In particular, the height of the engagement surfaces 52 may be less than the height or thickness of an individual blade 16, and more particularly, the height of the engagement surfaces 52 may be greater than about one-half of the height or thickness of each blade 16 and less than the thickness of a blade 16 to ensure each blade 16 is separately and sequentially engaged by the engagement surfaces 52.

[0023] Once the blade 16 and plate 44 are pivoted to an extracted position as shown in FIGS. 3 and 4, the blade 16 may be located at least partially outside the cavity 14 and a user can then grip the blade 16 along, for example, the short edge 18, and pull the blade 16 off of the pivot plate 44 (see FIG. 4). In this manner, because the sharp edge 24 of the blade 16 remains facing inwardly, and generally away from the user, exposure of the user to the sharp edge 24 of the blade may be minimized.

[0024] Once the blade 16 is dispensed and pulled off of the pivot plate 44, the pivot plate 44 can then returned to its retracted position. As the plate 44 is returned to its retracted position, the plate 44 (and in particular the teeth 50) may engage the stack of blades 16 and push them slightly upwardly (thereby compressing the spring 40) to create room in the cavity 14 to accommodate the pivot plate 44. The lowermost blade of the stack of blades 16 is then urged onto the pivot plate 44 by the spring 40 and/or magnet 60. The blade dispenser 10 is then ready for use to dispense another blade 16, when desired by the user, by again pivoting the pivot plate 44 away from its retracted position. Should a user need to replenish the stack of blades 16 in the cavity 14, the cover 28 can simply removed from the backing plate 26 as described above, and a new stack of blades 16 can be located inside the cavity 14.

[0025] The pivot plate 44 may include a magnet or magnetic component 60 located thereon. The magnet 60 can help to seat the lowermost blade 16b on to the seating surface 46 and to ensure that the blade 16 remains on the pivot plate 44 as the pivot plate 44 is pivoted away from its retracted position. The magnet 16 may be flush with, or raised slightly above or recessed below the seating surface 46.

[0026] The dispenser body 12 may include a bottom structure 64 which may support the pivot plate 44 thereon. The plate 44 may include a generally downwardly extending gripping tab 66 to facilitate gripping and rotation of the pivot plate. Furthermore, the bottom structure 64 may include a recess or cutout 68 located behind the tab 66 such that a user can easily fit his or her finger into the recess 68 and behind the tab 66 to facilitate easy operation of the pivot plate.

[0027] At least one of the body 12 or plate 44 may include a stop surface to limit pivoting motion of the plate. For example, as shown in FIG. 4, the inner surface 70 of the plate 44 may be shaped and located to engage an inner surface 72 of the backing plate 26 upon sufficient rotation of the pivot plate 44 away from the retracted position. In this manner, the interaction between the stop surfaces 70, 72 prevent over-rotation of the pivot plate 44.

[0028] For example, in one embodiment, rotation of the pivot plate 44 significantly beyond the position shown in FIG. 4 may be prevented to ensure that the blades 16 are not

pushed through the bottom of the cavity **14** by the spring. In other words, were the pivot plate **44** able to be completely pivoted away from the cavity **14**, the cavity would no longer have any "bottom" and the blades **16** could be pushed through the cavity **14** and out of the blade dispenser **10** by the spring **40**. In addition, if the plate **44** were to be over-rotated, it would be difficult to force the pivot plate **44** back under the bottom-most blade **16b** when returning the pivot plate **44** to its closed position. Accordingly, the stop surfaces **70**, **72** help to prevent over-rotation of the pivot plate **44** to ensure at least part of the pivot plate **44** remaining under the stack of blades **16**. Of course, various other structures, mechanisms, and arrangements for preventing over-rotation of the pivot plate **44** may be used.

[0029] Having described the invention in detail and by reference to the preferred embodiments, it will be apparent that modifications and variations thereof are possible without departing from the scope of the invention.

What is claimed is:

1. A blade dispenser comprising:
 - a dispenser body including a cavity shaped to store a plurality of blades therein; and
 - a pivotable plate located in or adjacent to said cavity such that said at least one blade stored in said cavity is receivable thereon, wherein said plate is pivotable such that a blade located thereon is movable at least partially outside of said cavity when said plate is pivoted such that a user can access a blade located on said plate, and wherein said plate includes a magnet located thereon to magnetically interact with a blade located on said plate to maintain said blade on said plate.
2. The blade dispenser of claim 1 wherein said dispenser body includes a biasing means for biasing said plurality of blades against said plate such that at least one of said blades is urged into contact with said plate.
3. The blade dispenser of claim 2 wherein said biasing means is a spring.
4. The blade dispenser of claim 1 wherein said plate includes an engagement surface shaped to engage at least one of said blades stored in said cavity when said plate is pivoted to separate said one of said blades from said a stack of blades stored in said cavity.
5. The blade dispenser of claim 4 wherein said cavity and plate are shaped to receive a plurality of generally trapezoidal blades, each blade having a short straight edge and a long straight edge generally parallel to said short straight edge, and wherein said engagement surface is located to engage said long straight edge of said one of said blades.
6. The blade dispenser of claim 1 further including a plurality of blades located in said cavity.
7. The blade dispenser of claim 6 wherein each blade includes at least one sharp edge, and wherein said plate includes an engagement surface that is shaped to engage said sharp edge of one of said blades when said plate is pivoted to separate said one of said blades from said plurality of blades.
8. The blade dispenser of claim 1 wherein at least one of said body or plate includes a stop surface to limit the pivoting motion of said plate.
9. The blade dispenser of claim 8 wherein said stop surface limits the pivoting motion of said plate such that at least part of said plate always remains located in or adjacent to said cavity.
10. The blade dispenser of claim 1 wherein said plate includes a generally downwardly-extending gripping tab to facilitate manual pivoting of said plate.
11. The blade dispenser of claim 1 wherein said plate is pivotable about a pivot axis which is located adjacent to an outer edge of said body.
12. The blade dispenser of claim 1 wherein said dispenser body includes backing surface and a cover removably coupled to said backing surface, said backing surface and said cover defining said cavity therebetween.
13. The blade dispenser of claim 1 wherein said cavity is generally trapezoidal in cross section.
14. A blade dispenser comprising:
 - a dispenser body including a cavity that is generally trapezoidal in cross section and shaped to generally receive and store a plurality of generally trapezoidal blades therein, each blade having a short straight edge and a long straight edge generally parallel to said short edge; and
 - a pivotable plate located in or adjacent to said cavity such that said at least one blade of said plurality of blades stored in said cavity is receivable thereon, wherein said plate is pivotable such that said at least one blade located thereon is movable at least partially outside of said cavity when said plate is pivoted such that a user can access said at least one blade, wherein said plate includes an engagement surface shaped to engage said at least one blade when said plate is pivoted to separate said one of said blades from said plurality of blades, said engagement surface being located to engage said long straight edge of said one of said blades.
15. The blade dispenser of claim 14 wherein said plate includes a generally flat seating surface shaped to receive a blade thereon, and wherein said engagement surface is oriented generally perpendicular to said seating surface.
16. The blade dispenser of claim 14 wherein said plate includes a magnet located thereon to magnetically interact with a blade located on said plate to maintain said blade on said plate.
17. The blade dispenser of claim 14 wherein said dispenser body includes a biasing means for biasing said plurality of blades against said plate such that at least one of said blades is urged into contact with said plate.
18. The blade dispenser of claim 16 wherein said biasing means is a spring.
19. The blade dispenser of claim 14 further including a plurality of blades located in said cavity.
20. The blade dispenser of claim 14 wherein at least one of said body or plate includes a stop surface to limit the pivoting motion of said plate.
21. The blade dispenser of claim 21 wherein said stop surface limits the pivoting motion of said plate such that at least part of said plate always remains located in or adjacent to said cavity.
22. The blade dispenser of claim 14 wherein said plate includes a generally downwardly-extending gripping tab to facilitate manual pivoting of said plate.

23. The blade dispenser of claim 14 wherein said plate is pivotable about a pivot axis which is located adjacent to an outer edge of said body.

24. The blade dispenser of claim 14 wherein said dispenser body includes backing surface and a cover removably coupled to said backing surface, said backing surface and said cover defining said cavity therebetween.

25. The blade dispenser of claim 14 wherein said cavity is generally trapezoidal in cross section.

26. A blade dispenser comprising:

a dispenser body including a cavity shaped to store a plurality of blades therein; and

a pivotable plate located in or adjacent to said cavity such that at least one blade of said plurality of blades stored in said cavity is receivable thereon, wherein said plate is pivotable such that a blade located thereon is movable at least partially outside of said cavity when said plate is pivoted such that a user can access said blade located on said plate, wherein at least one of said body or plate includes a stop surface to limit the pivoting motion of said plate.

27. The blade dispenser of claim 26 wherein said plate includes a magnet located thereon to magnetically interact with a blade located on said plate to maintain said blade on said plate.

28. The blade dispenser of claim 26 wherein said stop surface limits the pivoting motion of said plate such that at least part of said plate always remains located adjacent to said stack of blades to retain said blades in said cavity.

29. The blade dispenser of claim 26 wherein said dispenser body includes a biasing means for biasing said plurality of blades against said plate such that at least one of said blades is urged into contact with said plate.

30. The blade dispenser of claim 29 wherein said biasing means is a spring.

31. The blade dispenser of claim 26 wherein said plate includes an engagement surface shaped to engage at least one of said blades stored in said cavity when said plate is pivoted to separate said one of said blades from said a stack of blades stored in said cavity.

32. The blade dispenser of claim 31 wherein said cavity and plate are shaped to receive a plurality of generally trapezoidal blades, each blade having a short straight edge and a long straight edge generally parallel to said short straight edge, and wherein said engagement surface is located to engage said long straight edge of said one of said blades.

33. The blade dispenser of claim 26 further including a plurality of blades located in said cavity.

34. The blade dispenser of claim 33 wherein each blade includes at least one sharp edge, and wherein said plate includes an engagement surface that is shaped to engage said sharp edge of one of said blades when said plate is pivoted to separate said one of said blades from said plurality of blades.

35. The blade dispenser of claim 26 wherein said plate includes a generally downwardly-extending gripping tab to facilitate manual pivoting of said plate.

36. The blade dispenser of claim 26 wherein said plate is pivotable about a pivot axis which is located adjacent to an outer edge of said body.

37. The blade dispenser of claim 26 wherein said dispenser body includes backing surface and a cover removably coupled to said backing surface, said backing surface and said cover defining said cavity therebetween.

38. The blade dispenser of claim 26 wherein said cavity is generally trapezoidal in cross section.

* * * * *