



- (51) International Patent Classification:
A61M 15/00 (2006.01) G05D 23/00 (2006.01)
A24F 47/00 (2006.01)
- (21) International Application Number:
PCT/IL2016/050293
- (22) International Filing Date:
17 March 2016 (17.03.2016)
- (25) Filing Language: English
- (26) Publication Language: English
- (30) Priority Data:
14/662,607 19 March 2015 (19.03.2015) US
- (63) Related by continuation (CON) or continuation-in-part (CIP) to earlier application:
US 14/662,607 (CIP)
Filed on 19 March 2015 (19.03.2015)
- (72) Inventor; and
- (71) Applicant : RAICHMAN, Yossef [IL/IL]; 12 Tzamarot Street, Apt. 25, 4642411 Herzliya (IL).

(74) Agents: COLB Sanford T. et al.; Sanford T. Colb & Co., P.O. Box 2273, 76122 Rehovot (IL).

(81) Designated States (unless otherwise indicated, for every kind of national protection available): AE, AG, AL, AM, AO, AT, AU, AZ, BA, BB, BG, BH, BN, BR, BW, BY, BZ, CA, CH, CL, CN, CO, CR, CU, CZ, DE, DK, DM, DO, DZ, EC, EE, EG, ES, FI, GB, GD, GE, GH, GM, GT, HN, HR, HU, ID, IL, IN, IR, IS, JP, KE, KG, KN, KP, KR, KZ, LA, LC, LK, LR, LS, LU, LY, MA, MD, ME, MG, MK, MN, MW, MX, MY, MZ, NA, NG, NI, NO, NZ, OM, PA, PE, PG, PH, PL, PT, QA, RO, RS, RU, RW, SA, SC, SD, SE, SG, SK, SL, SM, ST, SV, SY, TH, TJ, TM, TN, TR, TT, TZ, UA, UG, US, UZ, VC, VN, ZA, ZM, ZW.

(84) Designated States (unless otherwise indicated, for every kind of regional protection available): ARIPO (BW, GH, GM, KE, LR, LS, MW, MZ, NA, RW, SD, SL, ST, SZ, TZ, UG, ZM, ZW), Eurasian (AM, AZ, BY, KG, KZ, RU, TJ, TM), European (AL, AT, BE, BG, CH, CY, CZ, DE, DK, EE, ES, FI, FR, GB, GR, HR, HU, IE, IS, IT, LT, LU, LV, MC, MK, MT, NL, NO, PL, PT, RO, RS, SE, SI, SK,

[Continued on next page]

(54) Title: VAPORIZER FOR VAPORIZING AN ACTIVE INGREDIENT

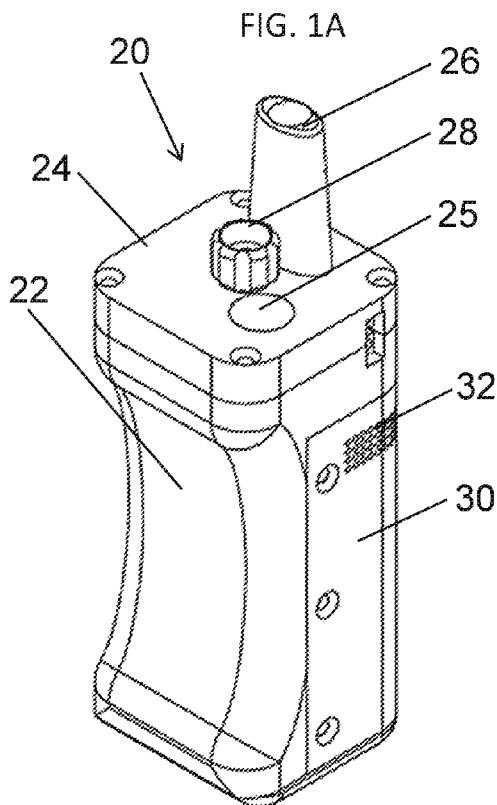

(57) Abstract: Apparatus and methods are described for use with a vaporizer (20) that vaporizes at least one active ingredient of a material (82). In response to receiving a first input to the vaporizer, the material is heated, in a first heating step. An indication of the temperature of the material is detected, and, in response to detecting an indication that the temperature of the material is at a first temperature, the first heating step is terminated, by withholding causing further temperature increase of the material. The first temperature is less than 9 percent of the vaporization temperature of the active ingredient. Subsequently, a second input is received at the vaporizer. In response thereto, the material is heated to the vaporization temperature, in a second heating step. Other applications are also described.

WO 2016/147188 A1



SM, TR), OAPI (BF, BJ, CF, CG, CI, CM, GA, GN, GQ, GW, KM, ML, MR, NE, SN, TD, TG).

— before the expiration of the time limit for amending the claims and to be republished in the event of receipt of amendments (Rule 48.2(h))

Published:

— with international search report (Art. 21(3))

VAPORIZER FOR VAPORIZING AN ACTIVE INGREDIENT

CROSS-REFERENCE TO RELATED APPLICATIONS

The present application claims priority from and is a continuation-in-part of US Patent Application 14/662,607 to Raichman, filed March 19, 2015, entitled "Vaporizer for vaporizing an active ingredient."
5

The above-referenced application is incorporated herein by reference.

FIELD OF EMBODIMENTS OF THE INVENTION

Some applications of the present invention generally relate to medical apparatus. Specifically, some applications of the present invention relate to vaporizers for the delivery of an active ingredient to a subject.
10

BACKGROUND

Medical use of cannabis and its constituent cannabinoids, such as tetrahydrocannabinol (THC) and cannabidiol (CBD), has a long history. In modern times, cannabis is used by patients suffering from AIDS, or undergoing chemotherapy treatment, in order to relieve nausea and vomiting associated with their conditions. Cannabis is also used in a medicinal manner in order to provide pain relief, to treat muscle spasticity, and to stimulate appetite.
15

Medicinal cannabis can be administered using a variety of methods, including vaporizing or smoking dried buds, eating extracts, taking capsules or using oral sprays. The legality of medical use of cannabis varies internationally. However, even in countries in which the medical use of cannabis is legal, the provision of cannabis to such users is highly regulated, and it is the case that in almost all Western countries, recreational use of cannabis is illegal.
20

SUMMARY OF EMBODIMENTS

In accordance with some applications of the present invention, a vaporizer is used to vaporize the active ingredient of a material, such as a plant material, by heating the material. For example, the vaporizer may be used to vaporize the constituent cannabinoids of cannabis (e.g., tetrahydrocannabinol (THC) and/or cannabidiol (CBD)). Alternatively
25

or additionally, the vaporizer may be used to vaporize tobacco, and/or other plant or chemical substances that contain an active ingredient that becomes vaporized upon the substance being heated.

Typically, the vaporizer houses a plurality of capsules, each of the capsules including a given amount of a plant material that contains an active ingredient. For some applications, the vaporizer is shaped to define first and second receptacles, each of which is shaped to house the plurality of capsules in stacked configurations. While each of the capsules is disposed at a vaporization location within the vaporizer, a heating element causes the active ingredient of the plant material within the capsule to become at least partially vaporized by individually heating the capsule. For some applications, the heating element includes one or more electrodes that heat the capsule via resistive heating, by driving a current into a portion of the capsule (e.g., into a metallic mesh of the capsule), or driving a current into an internal heating element that is housed within the vaporizer. Typically, a capsule-transfer mechanism of the vaporizer individually transfers each of the capsules from the first receptacle to the vaporization location and from the vaporization location to the second receptacle.

For some applications, a two step heating process is applied to the plant material, as follows. In response to receiving a first input at the vaporizer, a first heating step is initiated. The first heating step is terminated, and further heating of the plant material is withheld, in response to detecting an indication that the temperature of the plant material has reached a first temperature that is typically less than 95 percent of a vaporization temperature of the active ingredient. Subsequently, in response to receiving a second input at the vaporizer (e.g., in response to detecting that a user is inhaling from the vaporizer, or in response to the user pressing a button) the plant material is heated to the vaporization temperature of the active ingredient, in a second heating step.

Typically, the first heating step is performed at a faster heating rate than the second heating step. For some applications, by performing the heating in the two-stage process as described, one or more of the following results are achieved:

- 1) By withholding the first (rapid) stage of the heating in response to the temperature of the capsule reaching less than 95 percent of the vaporization temperature, even if the heating overshoots, the plant material is not pyrolyzed, since the plant material is not heated to a temperature that is greater than the pyrolysis temperature.

2) Since the second stage of the heating is performed slowly, there is negligible overshooting in the second stage of the heating process, and therefore the plant material does not get pyrolyzed in the second stage of the heating process.

3) Since, during the first stage of the heating, the plant material has already been heated to a temperature that is relatively close the vaporization temperature, even though the second stage of the heating is slow, the time that is required to heat the plant material to the vaporization temperature, from the initiation of the second heating stage, is relatively short (e.g., less than two seconds).

4) Due to low heat conduction of the plant material, if the plant material is heated rapidly, this can give rise to non-uniform heating of the plant material. This can cause some portions of the plant material to be pyrolyzed, and/or other portions of the plant material not to be vaporized. By withholding further heating of the plant material after the first temperature has been reached, and until the second input is received, heat is able to dissipate through the plant material (during the interim period between the first and second heating stages) before any portion of the plant material has been heated to the vaporization temperature. Furthermore, since the temperature increase during the second stage is relatively small, the temperature increase is able to dissipate through the plant material relatively quickly. Thus, relatively uniform heating of the plant material is achieved, such that most of the active ingredient within the plant material is vaporized, while there is substantially no pyrolysis of the plant material.

It is noted that some applications of the present invention are described with reference to a plant material that contains an active ingredient. However, the scope of the present invention includes using any material or substance that contains an active ingredient, *mutatis mutandis*.

There is therefore provided, in accordance with some applications of the present invention, a method for use with a vaporizer that vaporizes at least one active ingredient of a material, the method including:

receiving a first input at the vaporizer;

in response to receiving the first input, heating the material, in a first heating step;

detecting an indication of a temperature of the material;

in response to detecting an indication that the temperature of the material is at a first temperature, terminating the first heating step, by withholding causing further temperature increase of the material, the first temperature being less than 95 percent of a vaporization temperature of the active ingredient;

5 subsequently, receiving a second input at the vaporizer; and

in response to receiving the second input, heating the material to the vaporization temperature of the active ingredient, in a second heating step.

For some applications, detecting the indication of the temperature of the material includes detecting the indication of the temperature of the material using an optical
10 temperature sensor.

For some applications, the method further includes generating an indication that the first heating step has terminated.

For some applications, terminating the first heating step, by withholding causing further temperature increase of the material includes preventing pyrolysis of the active
15 ingredient.

For some applications, the method further includes, subsequent to the second heating step, in response to detecting that no air has been inhaled from the vaporizer for a given time period, reducing a temperature of the material to below the vaporization temperature of the material.

20 For some applications, the method further includes detecting a rate of air flow through the vaporizer by detecting an indication of an amount of energy required to maintain the temperature of the material constant.

For some applications, heating the material in the first heating step includes heating the material at a first heating rate, heating the material in the second heating step includes
25 heating the material at a second heating rate, and the first heating rate is greater than the second heating rate.

For some applications, heating the material at the second heating rate includes heating the material at a rate of less than 50 degrees Celsius per second.

For some applications, heating the material at the rate of less than 50 degrees
30 Celsius per second includes preventing pyrolysis of the active ingredient.

For some applications, heating the material at the first heating rate includes heating the material at a rate of more than 50 degrees Celsius per second.

For some applications, heating the material at the first heating rate includes heating the material at a rate of more than 100 degrees Celsius per second.

5 For some applications, heating the material at the first heating rate includes heating the material at a rate of more than 50 degrees Celsius per second.

For some applications, heating the material at the first heating rate includes heating the material at a rate of more than 100 degrees Celsius per second.

10 For some applications, receiving the second input includes detecting that a user is inhaling from the vaporizer.

For some applications, detecting that the user is inhaling from the vaporizer includes detecting the indication of the temperature of the material.

15 For some applications, detecting that the user is inhaling from the vaporizer includes detecting an indication of an amount of energy required to maintain the temperature of the material constant.

For some applications, the material includes cannabis and terminating the first heating step includes withholding causing further temperature increase of the material in response to detecting an indication that the temperature of the material has reached a temperature that is less than 170 degrees Celsius.

20 For some applications, terminating the first heating step includes withholding causing further temperature increase of the material in response to detecting an indication that the temperature of the material has reached a temperature that is less than 160 degrees Celsius.

25 For some applications, detecting the indication of the temperature of the material includes detecting a temperature of a capsule in which the material is housed.

For some applications, the capsule includes a metallic mesh, and detecting the temperature of the capsule includes detecting electrical resistance of the mesh.

There is further provided, in accordance with some applications of the present invention, apparatus for use with a material that includes at least one active ingredient, the apparatus including:

5 a vaporizer configured to vaporize the active ingredient of the material, the vaporizer including:

a heating element configured to heat the material;

a temperature sensor configured to detect an indication of a temperature of the material; and

control circuitry configured to:

10 receive a first input;

in response to receiving the first input, drive the heating element to heat the material at a first heating rate, in a first heating step;

15 in response to receiving, from the temperature sensor, an indication that the temperature of the material is at a first temperature, terminate the first heating step, by withholding causing further temperature increase of the material by the heating element, the first temperature being less than 95 percent of a vaporization temperature of the active ingredient;

subsequently, receive a second input at the vaporizer; and

20 in response to receiving the second input, drive the heating element to heat the material to the vaporization temperature of the active ingredient at a second heating rate that is less than the first heating rate, in a second heating step.

For some applications, the control circuitry is configured to be removed from the vaporizer and to be coupled to a second vaporizer.

25 For some applications, the apparatus further includes a phase-change material that is coupled to the capsule, the phase-change material being configured to undergo a phase change at a temperature that is below a pyrolysis temperature of the material.

For some applications, the capsule includes at least one hollow wire, and the phase-change material is housed inside the hollow wire.

30 There is further provided, in accordance with some applications of the present invention, apparatus including:

a vaporizer shaped to define at least first and second receptacles, the vaporizer including:

5 a plurality of capsules, each of the capsules including a material that contains an active ingredient, the first and second receptacles each being shaped to house the plurality of capsules in stacked configurations;

a heating element configured, while each of the capsules is disposed at a vaporization location within the vaporizer, to cause the active ingredient of the material within the capsule to become at least partially vaporized by individually heating the capsule; and

10 a capsule-transfer mechanism configured to individually transfer each of the capsules from the first receptacle to the vaporization location and from the vaporization location to the second receptacle.

For some applications, the capsule-transfer mechanism includes a rotating capsule-transfer mechanism, configured to transfer the capsules by rotating.

15 For some applications, the first and second receptacles and the vaporization location are linearly aligned with each other, and the capsule-transfer mechanism includes a linear capsule-transfer mechanism, configured to move each of the capsules by moving linearly.

20 For some applications, the heating element includes one or more electrodes configured to heat the capsules via resistive heating, by driving an electrical current into the portion of the capsule.

For some applications, each of the capsules includes one or more metallic meshes, and the one or more electrodes are configured to heat the capsules by driving the electrical current into the one or more metallic meshes of the capsule.

25 For some applications, a width of the vaporizer is less than 9 cm. For some applications, a depth of the vaporizer is less than 6 cm. For some applications, a height of the vaporizer is less than 20 cm.

There is further provided, in accordance with some applications of the present invention, a method including:

providing a vaporizer shaped to define at least first and second receptacles, a plurality of capsules being housed in a stacked configuration inside the first receptacle, and each of the capsules including a material that contains an active ingredient;

5 using a capsule-transfer mechanism individually transferring a first one of the capsules from the first receptacle to a vaporization location within the vaporizer;

when the first capsule is disposed at the vaporization location within the vaporizer, causing the active ingredient within the material within the first capsule to become at least partially vaporized by individually heating the capsule; and

10 using the capsule-transfer mechanism individually transferring the first capsule from vaporization location to the second receptacle, the second receptacle being configured to house a plurality of the capsules in a stacked configuration.

There is further provided, in accordance with some applications of the present invention, apparatus including:

a vaporizer including:

15 at least one capsule including:

upper and lower meshes; and

a given amount of a material housed between the upper and lower meshes, the material containing at least one active ingredient;

control circuitry; and

20 first, second, third and fourth electrodes,

the control circuitry being configured to vaporize the at least one active ingredient of the material by:

driving a current from the first electrode to the second electrode via the lower mesh, and

25 driving a current from the third electrode to the fourth electrode via the upper mesh.

There is additionally provided, in accordance with some applications of the present invention, a method including:

30 providing a capsule that includes upper and lower meshes, and a given amount of a material housed between the upper and lower meshes, the material containing at least one active ingredient; and

vaporizing the at least one active ingredient of the material by:

driving a current from a first electrode to a second electrode via the lower mesh, and

driving a current from a third electrode to a fourth electrode via the upper mesh.

5 There is further provided, in accordance with some applications of the present invention, apparatus including:

 a vaporizer including:

 at least one capsule, the capsule including a material that contains at least one active ingredient;

10 a heating element configured, to cause the active ingredient within the material within the capsule to become at least partially vaporized by heating the capsule; and

 a vibrator configured to vibrate the capsule.

 For some applications, the vibrator includes a vibrator selected from the group
15 consisting of: a vibration motor, a piezo-electric crystal, a sonic vibrator, and an ultrasonic vibrator.

 For some applications, the vibrator is configured to increase airflow through the capsule by vibrating the capsule.

 For some applications, the vibrator is configured to mix the material within the
20 capsule by vibrating the capsule.

 For some applications, the vibrator is configured to increase a uniformity of heating of the material within the capsule by vibrating the capsule.

 There is additionally provided, in accordance with some applications of the present invention, a method including:

25 providing a vaporizer that includes at least one capsule, the capsule including a material that contains at least one active ingredient;

 activating a heating element within the vaporizer to cause the active ingredient within the material to become at least partially vaporized by heating the capsule; and

 activating a vibrator within the vaporizer to vibrate the capsule.

There is further provided, in accordance with some applications of the present invention, apparatus including:

a vaporizer shaped to define at least one receptacle, the vaporizer including:

5 a plurality of capsules, each of the capsules including a material that contains an active ingredient, the receptacle being shaped to house the plurality of capsules in a stacked configuration, upon a supporting surface;

10 a screw, the supporting surface being threadedly coupled to the screw, such that, in response to the screw rotating in a given direction, the supporting surface is configured to push one of the capsule out of an opening of the receptacle by the supporting surface advancing toward the opening.

For some applications, the apparatus further includes a capsule-transfer mechanism configured to individually transfer each of the capsules from the opening of the receptacle to a vaporization location at which the vaporizer is configured to vaporize the active ingredient of the material.

15 There is additionally provided, in accordance with some applications of the present invention, apparatus including:

a vaporizer including:

at least one capsule including:

at least one mesh that defines at least a portion of an outer surface of the capsule;

20 and

material housed within the capsule, the material containing at least one active ingredient;

at least one electrode;

25 control circuitry configured to vaporize the at least one active ingredient of the material by driving a current into the mesh via the electrode; and

an electrode-movement mechanism configured to move the electrode with respect to the mesh.

30 For some applications, the apparatus further includes a coating disposed upon at least a portion of the outer surface of the capsule that is defined by the mesh, and the electrode-movement mechanism is configured to cause the electrode to penetrate the coating, by moving the electrode with respect to the mesh.

For some applications, the electrode-movement mechanism includes a button configured to be pressed by a user, and the electrode-movement mechanism is configured to move the electrode with respect to the mesh in response to the user pressing the button.

For some applications, the electrode-movement mechanism includes a hinge.

5 For some applications, the electrode-movement mechanism is configured to remove a coating from the mesh by moving the electrode with respect to the mesh.

For some applications, the electrode-movement mechanism is configured to cause the electrode to penetrate a coating on the mesh, by moving the electrode with respect to the mesh.

10 For some applications, the electrode-movement mechanism is configured to slide the electrode across the outer surface of the capsule that is defined by the mesh, while the electrode is in contact with the mesh.

For some applications, the electrode is shaped to define a sharp tip.

For some applications, the electrode is shaped to define a blade.

15 There is additionally provided, in accordance with some applications of the present invention, apparatus including:

a vaporizer configured to accommodate a mass of material that contains an active ingredient, the vaporizer including:

a surface;

20 an extraction mechanism configured, in response to being activated, to extract a given volumetric dose of the material from the mass of material and place the volumetric dose upon the surface; and

a heating element configured to vaporize the at least one active ingredient of the volumetric dose of the material by heating the surface while the volumetric dose is
25 disposed upon the surface.

For some applications, the vaporizer is shaped to define at least one receptacle that is configured to accommodate the mass of material.

For some applications, the surface includes a mesh, and the heating element includes one or more electrodes and control circuitry, the control circuitry being

configured to vaporize the at least one active ingredient of the volumetric dose of the material by driving a current into the mesh via the one or more electrodes.

For some applications, the mass of material includes a cigarette containing the material, and the extraction mechanism includes a blade that is configured to extract the
5 given volumetric dose of the material from the mass of material by cutting off a portion of the cigarette.

The present invention will be more fully understood from the following detailed description of embodiments thereof, taken together with the drawings, in which:

BRIEF DESCRIPTION OF THE DRAWINGS

10 Figs. 1A-C are schematic illustrations of respective views of the exterior of a vaporizer, in accordance with some applications of the present invention;

Figs. 2A-B are exploded views of the vaporizer of Figs. 1A-C, in accordance with some applications of the present invention;

15 Fig. 3A is a top view and Figs. 3B-D are respective cross-sectional views of the vaporizer of Figs. 1A-C, in accordance with some applications of the present invention;

Figs. 4A-D are schematic illustrations of respective views of a capsule that contains plant material that includes an active ingredient, in accordance with some applications of the present invention;

20 Fig. 5 is a schematic illustration of electrodes of the vaporizer in contact with a mesh of a capsule that contains plant material that includes an active ingredient, in accordance with some applications of the present invention;

Figs. 6A-D are schematic illustrations of respective configurations of the electrodes of the vaporizer, in accordance with some applications of the present invention;

25 Figs. 7A-B are schematic illustration of respective views of a vaporizer that includes a linear capsule-transfer mechanism, in accordance with some applications of the present invention;

Fig. 8 is a graph illustrating a technique for heating plant material using a vaporizer, in accordance with some applications of the present invention;

Figs. 9A-B are schematic illustrations of portions of a vaporizer, in accordance with some applications of the present invention;

Fig. 10A is a schematic illustration of an electrode, in accordance with some applications of the present invention;

5 Figs. 10B is a schematic illustration of an electrode-movement mechanism, in accordance with some applications of the present invention;

Figs. 11A-D are schematic illustrations of an electrode-movement mechanism, in accordance with some applications of the present invention;

10 Figs. 12A-B are schematic illustrations of an electrode-movement mechanism, in accordance with some applications of the present invention;

Figs. 13A-C are schematic illustrations of a vaporizer that is configured to automatically extract a given volumetric dose of a plant material from a mass of the plant material that is disposed in a receptacle of the vaporizer, in accordance with some applications of the present invention; and

15 Figs. 14A-C are schematic illustrations of a vaporizer that is configured to automatically extract a given volumetric dose of a plant material from a mass of the plant material that is disposed in a receptacle of the vaporizer, in accordance with some applications of the present invention.

DETAILED DESCRIPTION OF EMBODIMENTS

20 Reference is now made to Figs. 1A-C, which are schematic illustrations of respective views of the exterior of a vaporizer 20, in accordance with some applications of the present invention. Typically vaporizer 20 is used to vaporize the active ingredient of a material, such a plant material. For example, vaporizer 20 may be used to vaporize the constituent cannabinoids of cannabis (e.g., tetrahydrocannabinol (THC) and/or cannabidiol
25 (CBD)). Alternatively or additionally, the vaporizer may be used to vaporize tobacco, and/or other plant or chemical substances that contain an active ingredient that becomes vaporized upon the substance being heated. It is noted that some applications of the present invention are described with reference to a plant material that contains an active ingredient. However, the scope of the present invention includes using any substance that
30 contains an active ingredient, *mutatis mutandis*.

Vaporizer 20 includes a main body 22, which houses capsules and control circuitry of the vaporizer, as described in further detail hereinbelow. The control circuitry is configured to act as a control unit, which controls the functioning of the vaporizer. Typically, the vaporizer additionally includes a top cover 24, from which a mouthpiece 26 protrudes. During use, the user typically inhales the vaporized active ingredient via the mouthpiece.

Typically, vaporizer 20 is configured to be portable and, during use, the vaporizer is configured to be held in a single hand of a user. The dimensions of the vaporizer are typically as follows:

A height H1 of main body 22 of the vaporizer (excluding mouthpiece 26) is typically more than 8 cm (e.g., more than 10 cm), and/or less than 15 cm (e.g., less than 12 cm), e.g., between 8 cm and 15 cm, or between 10 and 12 cm.

A height H2 of mouthpiece 26, is typically more than 2 cm (e.g., more than 2.5 cm), and/or less than 6 cm (e.g., less than 3.5 cm), e.g., between 2 cm and 6 cm, or between 2.5 and 3.5 cm.

Typically, the total height of the vaporizer, including the mouthpiece is less than 20 cm, e.g., less than 15 cm.

A width W1 of the vaporizer is typically more than 3 cm (e.g., more than 4 cm), and/or less than 9 cm (e.g., less than 6), e.g., between 3 cm and 9 cm, or between 4 cm and 6 cm.

A depth D1 of the vaporizer is typically more than 2 cm (e.g., more than 3 cm), and/or less than 6 cm (e.g., less than 5), e.g., between 2 cm and 6 cm, or between 3 cm and 5 cm.

For some applications, a capsule-transfer wheel 28 is disposed on the outside of the top cover. The capsule-transfer wheel controls a capsule-transfer mechanism 44 (Fig. 2A). As described in further detail hereinbelow, the capsule-transfer mechanism is configured to (a) individually transfer unused capsules from a first receptacle 40A (Fig. 2A) within the main body of the vaporizer to a vaporization location 46 (Fig. 2A), at which the capsule is heated such as to vaporize the active ingredient, and (b) to individually transfer used capsules from the vaporization location to a second receptacle 40B (Fig. 2A) within the main body of the vaporizer. For some applications, the capsule-transfer mechanism is a

rotatable mechanism, e.g., a rotatable disc, as shown in Fig. 2A. For some such applications, the capsule-transfer wheel is turned by a user in order to control the rotatable capsule-transfer mechanism. Alternatively or additionally, the rotatable capsule-transfer mechanism (or any other capsule-transfer mechanism described herein) is controlled by an electric motor (not shown).

For some applications, a removable back cover 30 is disposed upon main body 22 of vaporizer 20. As shown, for some applications, the back cover defines a grill 32. Grill 32 is configured to allow airflow into the main body of the vaporizer, as described in further detail hereinbelow.

For some applications, the inner surface of mouthpiece 26 (and/or other portions of the vaporizer) includes a lipophobic or hydrophobic coating 27 that is configured to prevent products of the vaporization of the active ingredient from sticking to the inner surface of the mouthpiece. Alternatively or additionally, electrical charge is driven onto surfaces of the vaporizer (such as the inner surface of mouthpiece 26), such that the charge accumulates on the surfaces and repels products of the vaporization of the active ingredient from the surfaces.

Reference is now made to Figs. 2A-B, which are exploded views of vaporizer 20, in accordance with some applications of the present invention.

Referring to Fig. 2A, typically, vaporizer 20 includes first and second receptacles 40A and 40B, which are configured to house capsules 42, which include a plant material that contains an active ingredient. Unused capsules are typically housed in a stacked configuration inside the first receptacle, and used capsules are housed in a stacked configuration inside the second receptacle.

Capsule-transfer mechanism 44 is configured to transfer the capsules from the first receptacle to the second receptacle. For some applications, the capsule-transfer mechanism is a rotatable capsule-transfer mechanism (e.g., a rotatable disc), as shown in Fig. 2A. Typically, the capsule-transfer mechanism is configured to (a) individually transfer unused capsules from first receptacle 40A to vaporization location 46 at which the capsule is heated such as to vaporize the active ingredient, and (b) to individually transfer used capsules from the vaporization location to second receptacle 40B.

For some such applications, vaporizer 20 includes one or more heating elements, which are configured to heat the plant material within the capsule (such as to vaporize the active ingredient within the plant material). For some applications, electrodes 48 are configured to act as heating elements, by heating the plant material within the capsule, by driving an electrical current into capsule 42. For some applications, capsule 42 includes one or more metallic meshes 84 (Fig. 4A). The electrodes heat the plant material by heating the one or more meshes via resistive heating, by driving a current into the one or more meshes. Alternatively or additionally, the electrodes heat an internal heating element that is housed within the vaporizer, by driving a current into the internal heating element. Typically, the electric current that is driven is fixed, such that, for example, the heating of the capsules is not affected by variations in the degree of contact between the electrodes and the meshes of the capsules.

For some applications, a spring 49 with a pushing element 51 is disposed underneath a portion 25 of top cover 24. The spring is configured to push the used capsules into second receptacle 40B.

For some applications, a portion of capsule 42 is coated or filled with a phase-change material 47. The phase-change material is selected such as to maintain the capsule below the pyrolysis temperature of the plant material, and thereby prevents the plant material from being pyrolyzed. For example, the phase-change material may undergo a solid-to-liquid phase change at a temperature that is between the vaporization temperature and the pyrolysis temperature of the plant material, such that the phase-change material absorbs heat as latent heat of fusion at this temperature. For some applications, a portion of the vaporizer (e.g., vaporization location 46, receptacle 40A and/or receptacle 40B) is coated with phase-change material 47.

Referring now to Fig. 2B, typically, a power supply 50 (e.g., a battery) and control circuitry 52 are housed inside the main body of vaporizer 20. Typically, the power supply and/or the control circuitry are coupled to the main body of the vaporizer by a coupling element 53, such as an adhesive, a screw, a clip, and/or a pin. For some applications, the control circuitry is configured to drive a current into the capsule via electrodes 48, using power supplied by the power supply.

For some applications, back cover 30 is removable and reusable, and control circuitry 52, power supply 50, and/or temperature sensor 54 are coupled to the back cover

(e.g., by being housed in the back cover). Typically, for such applications, after all of the capsules in the vaporizer have been vaporized, the back cover is removed, together with the components that are coupled to the back cover. The back cover and the components are then transferred and coupled to a different vaporizer that includes unused capsules.

5 For some applications, vaporizer 20 includes a temperature sensor 54 that is configured to measure an indication of the temperature of the plant material that is being heated, e.g., by measuring the temperature of the capsule that is being heated. For example, the temperature sensor may be an optical temperature sensor, such as an infrared temperature sensor, that is configured to measure the temperature of the capsule without
10 contacting the capsule. In this manner, the infrared temperature sensor measures the temperature of the capsule, without affecting the temperature of the capsule by drawing heat from the capsule. For some applications, the temperature sensor is covered with a lipophobic or hydrophobic coating 56 that protects the temperature sensor from products of the vaporization being deposited upon the temperature sensor. For some applications, a
15 different temperature sensor is used. For example, the control circuitry may detect the temperature of the capsule by detecting changes in the resistance of components of the capsule (e.g., mesh 84 of the capsule) using electrodes 48.

As described hereinabove, typically unused capsules are housed inside first receptacle 40A and used capsules are housed inside receptacle 40B. Typically, springs 58
20 and pushing elements 60 are coupled to a bottom cover 62 of the vaporizer. The springs and pushing elements are configured to maintain the stacked configurations of the capsules inside the receptacles by pushing the capsules toward the top of the vaporizer.

Reference is now made to Figs. 3A-D. Figs. 3B-D are schematic cross-sectional views of vaporizer 20, in accordance with some applications of the present invention. Fig.
25 3A is a top view of vaporizer 20, in accordance with some applications of the present invention. Fig. 3A includes lines indicating the locations of the cross-sections that are shown, respectively, in Figs. 3B, 3C, and 3D.

Referring to Fig. 3B, for some applications, vaporizer 20 includes a vibrator 70 that is configured to vibrate capsule 42, while the capsule is being heated. During use of the
30 vaporizer, the user inhales via mouthpiece 26. This causes air to flow through grill 32 to the mouthpiece via the capsule, as indicated by airflow arrows 72. Due to the heating of the capsule the active ingredient within the plant material of the capsule is vaporized and is

introduced into the air that is flowing through the vaporizer. For some applications, by vibrating the capsule, the vibrator reduces blockage of air flow through the capsule, and/or increases airflow through the capsule relative to if the capsule were not vibrated. For some applications, due the vibration of the capsule, a greater amount of the active ingredient vaporizes and enters the airflow than if the capsule were not vibrated. Alternatively or additionally, vibration of the capsule improves the distribution of heat across the capsule, and/or mixes the plant material within the capsule.

In accordance with respective application, vibrator 70 includes a vibration motor, a piezo-electric crystal, a sonic vibrator, an ultrasonic vibrator, and/or a different type of vibrator. For some applications, one or more parameters of the vibration applied by the vibrator is varied such as to increase the efficiency of the active ingredient vaporization, to increase airflow through the capsule, to reduce air flow blockage, to improve distribution of heat across the capsule, and/or to mix the plant material within the capsule. For example, the frequency, the amplitude, and/or the direction of the vibration may be varied.

For some applications, vaporizer 20 includes a port 74 via which the vaporizer is connected to an external source of power and/or data input. For example, power supply 50 may be configured to be recharged by connecting the vaporizer to an external power source via port 74. Alternatively or additionally, control circuitry 52 may receive data, e.g., programming instructions, via port 74.

For some applications, a healthcare professional (e.g., a pharmacist or a doctor) may input instructions into the control circuitry that control the heating rate that is applied for a given amount of air flow through the capsule. By controlling the heating rate per unit air flow, the amount of the active ingredient that is vaporized per unit airflow through the vaporizer may be controlled. Alternatively or additionally, the healthcare professional may input instructions into the control circuitry that control the amount of airflow through the vaporizer that is permitted during each use of the vaporizer, and/or the amount of airflow through the vaporizer that is permitted within a given time period (e.g., per hour, or per day). In this manner, the healthcare professional may control the dosage of the active ingredient that the user is able to receive during each use of the vaporizer, and/or within the given time period. For some applications, the control circuitry is configured to automatically determine the rate and/or volume of air flow through the vaporizer, as described in further detail hereinbelow.

Referring now to Fig. 3C, as shown, capsules 42 that are unused (i.e., capsules, the active ingredient of the plant material of which has not been vaporized) are housed, in a stacked configuration (i.e., such that when the vaporizer is in an upright orientation, the capsules are arranged one above the other), inside receptacle 40A. Used capsules are housed, in a stacked configuration, inside receptacle 40B. As described hereinabove, for some applications, springs 58 and pushing elements 60 are coupled to a bottom cover 62 of the vaporizer and are configured to maintain the stacked configurations of the capsules inside the receptacles by pushing the capsules toward the top of the vaporizer. For some applications, by storing the capsules in stacked configurations, dimensions of the width and depth of vaporizer 20 may be such that the vaporizer can be comfortably held by a user (e.g., within a single hand of the user).

Spring 49 and pushing element 51 typically push the used capsules into receptacle 40B, such that the used capsules are maintained below a plane of movement of capsule-transfer mechanism 44. In this manner, capsules that have been placed inside receptacle 40B remain inside receptacle 40B, even when the capsule-transfer mechanism is moved.

For some applications, capsules 42 have circular cross-sections, and receptacles 40A and 40B define cylindrical tubes that house the capsules. Alternatively, capsules 42 may have a different shape, and receptacles 40A and 40B may define hollow spaces that are shaped so as to conform with the shapes of the capsules.

With reference to Fig. 3D, as described hereinabove, for some applications, temperature sensor 54 is an optical temperature sensor, such as an infrared temperature sensor, that is configured to measure the temperature of the capsule without contacting the capsule. Fig. 3D shows sensor 54 receiving beams 80 of optical light from capsule 42, the capsule having been heated. Sensor 54 is configured to measure the temperature of capsule 42, based upon the received light.

As shown in Fig. 3D, for some applications, electrode 48 includes at least four electrodes 48A, 48B, 48C, and 48D. The plant material contained within the capsule is heated by driving a current from first electrode 48A to second electrode 48B via a lower mesh of capsule 42. Alternatively or additionally, plant material contained within the capsule is heated by driving a current from third electrode 48C to fourth electrode 48D via an upper mesh of capsule 42. For some applications, by heating the plant material in the aforementioned manner, the plant material within the capsule is heated more uniformly

than if, for example, a monopolar electrode were to drive a current into a location on the upper or lower mesh. For some applications, capsule 42 includes an internal heating element (e.g., an internal mesh (not shown)), as an alternative or in addition to the upper and lower meshes. The internal heating element is configured to be heated in a similar
5 manner to that described with reference to the upper and lower meshes.

Reference is now made to Figs. 4A-D, which are schematic illustrations of respective views of capsule 42, the capsule containing plant material 82 that includes an active ingredient, in accordance with some applications of the present invention. As described hereinabove, for some applications, the plant material is cannabis, and the active
10 ingredient is the constituent cannabinoids of cannabis (e.g., tetrahydrocannabinol (THC) and/or cannabidiol (CBD)). Alternatively or additionally, the plant material may be tobacco, and/or other plant or chemical substances that contain an active ingredient that becomes vaporized upon the substance being heated.

For some applications, plant material 82 is housed between upper and lower
15 metallic meshes 84. For some applications, each of the meshes has openings of more than 15 micron (e.g., more than 20 micron), and/or less than 80 micron (e.g., less than 50 micron), e.g., 15-60 micron, or 20-50 micron. Typically the meshes are coupled to a central portion 86 of the capsule (e.g., a central disc, as shown), the central portion defining a hole. For example, the meshes may be coupled to the central portion via an
20 adhesive 88, such as a high-temperature-resistant glue, or double-sided adhesive. Typically, the adhesive is configured such that the adhesive does not emit fumes, even when the adhesive is subjected to a high temperature, such as a temperature of greater than 200 degrees Celsius. Typically, the plant material is housed between the meshes and within the hole defined by the central portion of the capsule.

Typically, plant material 82 is ground, such that (a) the plant material is in
25 sufficiently small pieces that the material fits within the capsule, and a large surface area of the plant material is exposed to air flow through the vaporizer (b) the pieces of the plant material are sufficiently large that they do not pass through the meshes, and (c) the active ingredient retains its potency. For some applications, the plant material is cryogenically
30 ground and/or powdered.

For some applications, spacing elements 90 are coupled to the outside of one or both of the meshes. The spacing elements are configured such that, when the capsules are

disposed in the stacked configuration inside the vaporizer, there is a space between the upper mesh of a capsule and the lower mesh of the adjacent capsule. The spacing elements are shaped such as to perform the aforementioned function without blocking airflow through the meshes and/or the plant material, and without interfering with the contact
5 between electrodes 48 and meshes 84. For some applications, the spacing element is a single sided adhesive tape. For some applications, an anti-adhesive coating material is used as the spacing element. The anti-adhesive coating material is configured to prevent the unused capsules from becoming stuck to one another when the unused capsules are housed in receptacle 40A.

10 For some applications, central portion 86 of capsule 42 is made of a material that has a high heat capacity and/or low heat conductivity so that it reduces heat loss from the capsule to the surrounding area and reduces heating of the surrounding area during evaporation process. For some applications, at least one of the wires of meshes 84 is hollow, and a phase-change material is disposed inside the hollow wire. The phase-change
15 material reduces heat loss from the capsule, by causing the capsule to preferentially absorb heat relative to the areas surrounding the capsule. Alternatively or additionally, a phase change material is coupled to the capsule in a different manner, e.g., by coating the capsule. As described hereinabove, typically, the phase-change material is selected such as to maintain the capsule below the pyrolysis temperature of the plant material, and to
20 thereby prevent the plant material from being pyrolyzed.

Reference is now made to Fig. 5, which is a schematic illustration of electrodes 48 of vaporizer 20 in contact with meshes 84 of capsule 42, in accordance with some applications of the present invention. As shown, electrodes 48 contact the meshes even when spacing elements 90 are disposed upon the outsides of the meshes.

25 Reference is now made to Figs. 6A-D, which are schematic illustrations of respective configurations of electrodes 48 of vaporizer 20, in accordance with some applications of the present invention. Fig. 6A shows examples of electrodes 48A and 48B, in accordance with some applications of the present invention. As shown, for some applications, a surface 92 of the electrode acts as an electrical contact, via which electrical
30 contact is made with a mesh of the capsule. Figs. 6B-D show examples of electrode 48B, in accordance with respective applications of the present invention. For some applications, the electrodes include contacts 94 that protrude from surface 92 of the electrode. As

shown, the contact may be shaped as a flat plate (Fig. 6B), or as a plurality of points, e.g., two points (Fig. 6C), or three points (Fig. 3D).

Reference is now made to Figs. 7A-B, which are schematic illustrations of respective views of vaporizer 20, capsule-transfer mechanism 44 of the vaporizer being a
5 linear mechanism, in accordance with some applications of the present invention.

As shown in Figs. 7A-B, in accordance with some applications, capsules 42 are shaped in a shape that is not circular. For example, as shown in Figs. 7A-B, the capsule may have a racetrack-shaped cross section. For such applications, receptacles 40A and 40B define hollow spaces that are shaped so as to conform with the shape of the capsules.

10 For some applications, the top of receptacle 40A, the top of receptacle 40B, and the vaporization location, at which the capsules are heated, are aligned with each other (for example, across the width of the vaporizer, as shown in Figs. 7A-B). A linear capsule-transfer mechanism 44 is configured to push unused capsules from receptacle 40A to vaporization location 46 at which the capsule is heated, and from the vaporization location
15 to second receptacle 40B. For some applications, the linear capsule-transfer mechanism includes a pusher 100 that is configured to transfer the capsules in the manner described above, by the pusher being pushed axially in a given direction. For some applications, a spring 102 is coupled to the pusher, the spring being configured to apply a force to the pusher that opposes movement of the pusher in the given direction.

20 With reference to Fig. 7B, for some applications, a pump 200 (shown schematically in Fig. 7B) is used to control air flow through the vaporizer. For some applications, the vaporizer is shaped to define a supplementary airflow channel 201, which provides airflow out of the mouthpiece, but not via the capsule that is being vaporized. In this manner, in response to a large inhalation by the user, the vaporizer is able to provide air to the user,
25 without increasing the dosage of the active ingredient that is provided to the user. For some applications, a valve 203 (shown schematically in Fig. 7B) is disposed within the supplementary airflow channel and is configured to control airflow through the supplementary airflow channel.

For some applications, vaporizer 20 includes an airflow sensor, e.g., a valve
30 202(shown schematically in Fig. 7B). The valve is configured to measure airflow through the vaporizer. For some applications, the measured airflow is received as an input to the

control circuitry, and the control circuitry varies a parameter of the heating in response to the detected airflow.

Apart from the differences described in the above paragraphs, vaporizer 20 and portions thereof shown in Figs. 7A-B are generally similar to the vaporizer and portions thereof described with reference to Figs. 1A-6D. The scope of the present invention includes combining features of the vaporizer and portions thereof described with reference to Figs. 7A-B, with features of the vaporizer and portions thereof described with reference to Figs. 1A-6D, and vice versa.

Reference is now made to Fig. 8, which is a graph illustrating respective techniques for heating plant material using a vaporizer, such as vaporizer 20, in accordance with some applications of the present invention. The x-axis of the graph indicates time (measured in seconds), and the y-axis indicates the temperature (measured in degrees Celsius) of a capsule that contains a plant material (and therefore indicates the temperature of the plant material within the capsule), as described herein.

As described hereinabove, for some applications, vaporizer 20 is used to vaporize active ingredients within cannabis. Cannabis typically has a vaporization temperature of 180 degrees Celsius, and begins to become pyrolyzed at 220 degrees Celsius. Therefore, it is typically desirable to heat the cannabis to a temperature of between 190 degrees Celsius and 210 degrees Celsius. The upper and lower boundaries of the desired temperature range to which to heat cannabis are denoted on the graph of Fig. 8, by the two solid horizontal lines at 190 degrees Celsius and 210 degrees Celsius. Further typically, it is desirable not to heat the cannabis to a temperature that is greater than the described temperature, in order to prevent pyrolysis of the cannabis. Typically, when the vaporizer is used with plant materials other than cannabis, similar considerations are applicable, although the desired temperature to which the plant material should be heated will vary depending on the characteristics of the plant material that is being used with the vaporizer.

One possible way of heating the plant material to the desired temperature is via gradual heating, as denoted by the dashed diagonal line, which shows the plant material being heated to the desired temperature over a period of more than 8 seconds. Another possible way to heat the plant material is via rapid heating, as denoted by the dotted curve in Fig. 8. Typically, if the plant material is heated rapidly, then initially there is an overshoot in the temperature to which the plant material is heated. For example, this may

be because there is a time lag between when the plant material reaches the desired temperature and when the control circuitry detects that the desired temperature has been reached and withholds causing further temperature increase of the plant material in response to the detected temperature. This is indicated in Fig. 8, which shows that the dotted curve initially rises above 220 degrees Celsius, before plateauing within the desired temperature range. Due to the overshooting, some of the plant material may become pyrolyzed.

In accordance with some applications of the present invention, a two-stage heating process is applied to plant material within a vaporizer, e.g., as indicated by the solid curve shown in Fig. 8. Typically, in response to receiving a first input at the vaporizer (e.g., in response to the user pressing an ON switch on the vaporizer), the control circuitry of the vaporizer initiates a first heating step. Typically, the first heating step is a rapid heating step (e.g., a heating step in which the capsule that contains the plant material is heated at a rate of more than 50 degrees Celsius per second, or more than 100 degrees Celsius per second). Further typically, the control circuitry of the vaporizer is configured to terminate the first heating step, by withholding causing further temperature increase of the capsule, in response to detecting that the temperature of the capsule (which is indicative of the temperature of the plant material) has reached a first temperature. Typically, the first temperature is less than 95 percent, e.g., less than 90 percent, or less than 80 percent, of the vaporization temperature of the plant material. For example, when the vaporizer is used to vaporize cannabis, the control circuitry of the vaporizer may be configured to withhold causing further temperature increase of the capsule, in response to detecting that the temperature of the capsule has reached a first temperature that is less than 170 degrees Celsius (e.g., less than 160 degrees Celsius), e.g., a temperature that is between 140 and 170 degrees Celsius, or between 150 and 160 degrees Celsius.

By configuring the control circuitry to terminate the first, rapid heating stage as described above, even if there is overshoot, and the temperature of the capsule rises above the temperature at which the first heating stage was programmed to be terminated, the temperature of the capsule will typically still not rise above the pyrolysis temperature of the plant material. For example, as shown in Fig. 8, the control circuitry has been configured to withhold causing further temperature increase of the capsule in response to detecting that the temperature of the capsule has reached approximately 160 degrees

Celsius. Initially (at approximately 0.5 second), there is an overshoot, and the temperature of the capsule reaches approximately 180 degrees Celsius. However, the temperature of the capsule then reaches a plateau of approximately 160 degrees Celsius, at about 1 second. For some applications, the control circuitry of the vaporizer generates an output to the user to indicate that the first stage of the heating has terminated. For example, the control circuitry may illuminate an indicator light, may cause the vaporizer to vibrate, and/or may emit an audio signal (e.g., a beep).

Subsequently, in response to a second input to the vaporizer, the control circuitry of the vaporizer initiates a second heating step (shown, on the solid curve in Fig. 8, to begin at approximately 3 seconds). Typically, between the end of the first stage of the heating process, and the initiation of the second stage of the heating process, the control circuitry maintains the temperature of the capsule at the first temperature. For some applications, the second stage of the heating is initiated automatically in response to inhalation of air from the vaporizer by a user. Alternatively, the second stage of the heating process may be initiated in response to a different input by the user (e.g., the user pressing the ON button a second time).

During the second heating step, the control circuitry typically heats the capsule at a slower rate than during the first stage of the heating process. For example, during the second stage of the heating process, the meshes of the capsules of the vaporizer may be heated at a rate of less than 50 degrees Celsius per second, e.g., less than 40 degrees Celsius per second. As shown in Fig. 8, during the second stage of the heating process (from 3 seconds to 5 seconds) the capsule is heated from approximately 160 degrees Celsius to 200 degrees Celsius.

In the second stage of the heating process, the control circuitry is configured to withhold causing further temperature increase of the capsule in response to detecting that the temperature of the capsule is between the vaporization temperature of the plant material and the pyrolysis temperature of the plant material. For example, when the vaporizer is used to vaporize cannabis, the control circuitry of the vaporizer is configured to withhold causing further temperature increase of the capsule, in response to detecting that the temperature of the capsule has reached a second temperature that is more than 180 degrees Celsius (e.g., more than 190 degrees Celsius), and/or less than 220 degrees Celsius

(e.g., less than 210 degrees Celsius), e.g., a temperature that is between 180 and 220 degrees Celsius, or between 190 and 210 degrees Celsius.

For some applications, by performing the heating in the two-stage process described hereinabove, one or more of the following results are achieved:

5 1) By terminating the first (rapid) stage of the heating in response to the temperature of the capsule reaching less than 95 percent of the vaporization temperature, even if the heating overshoots, the plant material is not pyrolyzed, since the plant material is not heated to a temperature that is greater than the pyrolysis temperature.

10 2) Since the second stage of the heating is performed slowly, there is negligible overshooting in the second stage of the heating process, and therefore the plant material does not get pyrolyzed in the second stage of the heating process.

15 3) Since, during the first stage of the heating, the plant material has already been heated to a temperature that is relatively close the vaporization temperature, even though the second stage of the heating is slow, the time that is required to heat the plant material to the vaporization temperature, from the initiation of the second heating stage, is relatively short (e.g., less than two seconds).

20 4) Due to low heat conduction of the plant material, if the plant material is heated rapidly, this can give rise to non-uniform heating of the plant material. This can cause portions of the plant material that are near to the heating element(s) (e.g., the electrode(s)) to be pyrolyzed, and/or portions of the plant material that are further from the heating element(s) not to be vaporized. By withholding further heating of the plant material after the first temperature has been reached, and until the second input is received, heat is able to dissipate through the plant material (during the interim period between the first and second heating stages) before any portion of the plant material has been heated to the vaporization temperature. Furthermore, since the temperature increase during the second stage is relatively small, the temperature increase is able to dissipate through the plant material relatively quickly. Thus, relatively uniform heating of the plant material is achieved, such that most of the active ingredient within the plant material is vaporized, while there is substantially no pyrolysis of the plant material.

30 For some applications, inhalation from the vaporizer by the user is automatically detected by the control circuitry. After the first stage of the heating, there is typically a

large difference between the ambient temperature and the temperature of the capsule that contains the plant material. As described hereinabove, between the end of the first stage of the heating process, and the initiation of the second stage of the heating process, the control circuitry maintains the temperature of the capsule at the first temperature. Since
5 there is a large difference between the ambient temperature and the temperature of the capsule, the energy that is required to maintain the capsule (and the plant material therein) at a constant temperature is greater when the user is inhaling from the vaporizer than when the user is not inhaling. Therefore, for some applications, the control circuitry detects that the user is inhaling from the vaporizer by detecting an indication of an amount of energy
10 that is required to maintain the temperature of the capsule (and the plant material therein) constant. For example, the control circuitry may detect variations in the duty cycle that is used to heat the capsule (and the plant material therein). Alternatively or additionally, the control circuitry may automatically detect that the user is inhaling from the vaporizer by directly detecting the temperature of the capsule. Since, after the first stage of the heating,
15 there is a large difference between the ambient temperature and the temperature of the capsule, airflow through the capsule may cause a measurable change in the temperature of the capsule. As described hereinabove, for some applications, the second stage of the heating process is initiated automatically in response to detecting inhalation from the vaporizer by the user.

20 Using a generally similar technique to that described hereinabove, for some applications, the control circuitry detects a rate and/or volume of air flow through the vaporizer, by detecting an indication of an amount of energy that is required to maintain the temperature of the capsule (and the plant material therein) constant. For some applications, in response to the detected rate of air flow through the vaporizer, the control
25 circuitry calculates that dosage of the active substance that has been administered to the subject. As described hereinabove, for some applications, a healthcare professional may input instructions into the control circuitry that control the amount of airflow through the vaporizer that is permitted during each use of the vaporizer, and/or the amount of airflow through the vaporizer that is permitted within a given time period (e.g., per hour, or per
30 day). Alternatively or additionally, the control circuitry may control the heating rate per unit air flow, as described hereinabove.

For some applications, in response to detecting that no inhalation has occurred over a given time period (e.g., a time period of between 0.5 seconds and 3 seconds), the temperature of the capsule is reduced to below the vaporization temperature of the plant material. For example, during use of the vaporizer, the user may stop inhaling for a given
5 time period, due to coughing, and/or due to irritation caused by the plant material. By reducing the temperature to below the vaporization temperature, wastage of the active ingredient during this period is reduced, such that the user is able to receive the prescribed dosage of the active ingredient.

As indicated by the solid curve in Fig. 8, between approximately 7 seconds and 9.5
10 seconds the control circuitry causes the temperature of the capsule to be lowered to below the vaporization temperature. This may be performed in response to detecting that no inhalation has occurred over a given time period (as described hereinabove), and/or in response to a user input (e.g., in response to the user pressing a button). From approximately 9.5 seconds to 12.5 seconds, the capsule is heated back to the vaporization
15 temperature. This may be performed in response to detecting that inhalation has resumed and/or in response to a user input (e.g., in response to the user pressing a button). Between approximately 14 seconds and 16 seconds the control circuitry again causes the temperature of the capsule to be lowered to below the vaporization temperature. This may be performed in response to detecting that no inhalation has occurred over a given time
20 period, and/or in response to a user input (e.g., in response to the user pressing a button).

Although vaporizer 20 has been described as using resistive heating of electrode(s)
48 to heat capsule 42, for some applications, alternative or additional heating elements and heating techniques are used to heat the capsule. For example, a laser emitter may act as a heating element by directing a laser beam at the capsule, in order to heat the capsule. For
25 some applications, a separate heating element that is housed inside the vaporizer is heated in proximity to the vaporization location, in order to provide conduction, convection, and/or radiation heating to the capsule.

For some applications, the vaporizer includes an indicator that indicates to the user how many unused capsules are housed within the vaporizer. Typically, the vaporizer is
30 configured such that it can only be opened and/or refilled by a healthcare professional (e.g., a doctor, or a pharmacist). For some applications, rather than the vaporizer being configured to be refilled, some of the control components of the vaporizer are recyclable

and are transferrable to an unused vaporizer, as described hereinabove. For some applications, the size of the capsules and/or the amount of plant material in each capsule that is to be provided to a given user may be determined by a healthcare professional. In addition, as described hereinabove, the vaporizer is typically programmable, such that only
5 a certain dosage of the active ingredient may be released per use or within a given time period. In this manner, if the plant material that is used inside the vaporizer is a regulated substance (e.g., cannabis), control over the use of the substance may be maintained. For some applications, the vaporizer and/or the capsules include identifying marks or tags (e.g., an RFID or a barcode), such as to facilitate regulation and control of the use of the
10 vaporizer and the capsule.

Reference is now made to Figs. 9A-B, which are schematic illustrations of portions of vaporizer 20, in accordance with some applications of the present invention. For some applications, unused capsules 42 are stored in a stacked configuration inside receptacle 40A, upon a supporting surface 110. Figs. 9A and 9B show the supporting surface in the
15 absence of the walls of the receptacle, for illustrative purposes. Fig. 9A shows the supporting surface in the absence of any capsule, and Fig. 9B shows the supporting surface with a stack of capsules disposed thereon.

Typically, a spring 112 is disposed underneath the supporting surface. For some applications, in response to the user rotating a capsule-transfer wheel 114 in a given
20 direction (e.g., clockwise or counter-clockwise), a screw 113, which is coupled to the capsule-transfer wheel, is rotated in the given direction. Typically, the supporting surface is (directly or indirectly) threadedly coupled to the screw. For example, as shown, supporting surface 110 may be coupled to a second surface 116 via spring 112, the second surface being directly coupled to the screw with threading. In response to the screw
25 rotating in the given direction, the supporting surface advances toward the opening of receptacle 40A, thereby pushing the top capsule out of the opening of the receptacle.

It is noted that capsule-transfer wheel 114 is shaped differently from the shape of capsule-transfer wheel 28 described hereinabove. Typically, as described with respect to capsule-transfer wheel 28, capsule-transfer wheel 114 is configured to control the capsule-
30 transfer mechanism, which, in turn, is configured to (a) individually transfer unused capsules from receptacle 40A to vaporization location 46, at which the capsule is heated

such as to vaporize the active ingredient, and (b) to individually transfer used capsules from the vaporization location to second receptacle 40B.

It is noted that, typically, using the mechanism shown in Figs. 9A-B results in the force with which the capsules are advanced through receptacle 40A being substantially constant, irrespective of how full the receptacle is. For some applications, using the mechanism shown in Figs. 9A-B, a smaller spring can be used to push the capsule out of first receptacle 40A than is typically used with a first receptacle configured as shown in Figs. 3C and 7B, for example. This is because, as the first receptacle becomes emptier, supporting surface 110 advances up through the first receptacle. By contrast, for the applications shown in Figs. 3C and 7B, for example, spring 58 must be large enough such that when the first receptacle is relatively empty, the spring extends along most of the height of the first receptacle and exerts pressure upon the unused capsules. Therefore, for some applications, by using the mechanism shown in Figs. 9A-B, a greater number of capsules can be accommodated within a receptacle of a given height than would be possible if other mechanisms were used.

For some applications, it is sometimes that case that, in response to the rotation of the capsule-transfer wheel, a capsule does not exit receptacle 40A, e.g., due to adhesion between one or more of the capsules and the walls of receptacle 40A. For some applications, in such cases, capsule-transfer wheel 114 is further rotated. This typically increases the force that is exerted upon the stack of capsules by spring 112, thereby releasing the capsules.

Reference is now made to Figs. 10A-B, 11A-D, and 12A-B, which are schematic illustrations of electrodes 48 and mechanisms for use therewith, in accordance with some applications of the present invention. As described hereinabove, for some applications, outer surfaces of the capsules are defined by one or more meshes. Electrodes 48 heat the plant material inside capsules 42 by heating the one or more meshes of the capsules via resistive heating, by driving a current into the one or more meshes. Typically, for such applications, a high-quality and low-resistance electrical contact between the electrodes and the meshes of the capsules is desirable. However, for some applications, a non-conductive coating develops on the surfaces of the meshes before the capsule is used. For example, this may be due to the emission of vapors by the active ingredient in the plant material, and/or due to oxidation. For some applications, at least a portion of the outer

surfaces of the meshes is covered with a soft, penetrable protective coating (such as wax). The coating reduces (e.g., prevents) development of the non-conductive coating (e.g., due to oxidation) on the surface of the mesh.

For some applications, the electrodes and mechanisms for use therewith shown in
5 Figs. 10A-B, 11A-D, and 12A-B facilitate high-quality and low-resistance electrical contact between the electrodes and the meshes of the capsules by increasing the pressure that the electrodes exert upon the meshes relative to other possible configurations (for example, by increasing the force that the electrodes exert on the meshes, and/or by reducing the contact area between the electrodes and the meshes). For some applications,
10 the electrodes and mechanisms for use therewith shown in Figs. 10A-B, 11A-D, and 12A-B facilitate high-quality and low-resistance electrical contact between the electrodes and the meshes of the capsules by causing the electrodes to penetrate a coating that has developed on the surfaces of the meshes, and/or a protective coating with which the surfaces of the mesh have been covered, as described hereinabove.

15 Referring now to Figs. 10A-B, for some applications, one or more of electrodes 48 have sharp tips. For example, as shown in Fig. 10A, the electrodes may be shaped as blades. Typically, the tips of the blades have a thickness of more than 0.05 mm (e.g., more than 0.1 mm), and/or less than 0.4 mm (e.g., less than 0.3 mm), e.g., between 0.05 mm and 0.4 mm, or between 0.1 mm and 0.3 mm.

20 For some applications, an electrode-movement mechanism 120 is configured to move at least a portion of the electrodes with respect to a mesh of capsule 42. For example, the electrode-movement mechanism may move the electrodes closer to the mesh, and/or may move the electrodes with respect to the mesh (e.g., by sliding the electrodes across the surface of the mesh), while the electrodes are in contact with the mesh. In this
25 manner, the electrodes typically remove at least a portion of a coating that has developed on the surface of the mesh, and/or penetrate the coating.

For some applications, the electrode-movement mechanism 120 includes springs 131, which push at least some of the electrodes toward a mesh of the capsule. The electrodes are also connected to a button 122. For some applications, the user slides the
30 electrodes across the surface of the mesh of the capsules, while the springs are pushing the electrodes against the mesh, such as to remove the coating from the mesh. Alternatively or additionally, using the button, the user pushes the electrodes downward (against the force

applied to the electrodes by the spring). When the button is released, the electrodes are pushed upward with force, toward the mesh, by the springs. For some applications, the user repeatedly pushes button 122 downward, such that the springs repeatedly apply the electrodes with force against the mesh, in a pecking action.

5 For some applications, the upper electrodes remain stationary, and are configured to penetrate any coating on the surface of the mesh that they contact, due to the pressure that the electrodes exert upon the surface of the mesh. For example, in the example shown in Fig. 10B, the upper electrodes may penetrate any coating on the surface of the upper mesh of the capsule, due the upper mesh of the capsule being pushed against the sharp tips
10 of the electrodes. For some applications, button 122 is additionally configured to cause the vaporizer to operate by being pushed. For example, button 122 may be configured to switch on an operating switch by being pushed, which may cause the control circuitry to heat the meshes of the capsule using techniques as described herein.

Referring now to Figs. 11A-D, for some applications, electrode-movement
15 mechanism 120 includes one or more hinges 130 and a button 132. For some such applications, electrodes 48 are shaped as described hereinabove, with reference to Fig. 10A. Fig. 11A shows the mechanism disposed within a portion of vaporizer 20, Fig. 11B is a three-dimensional schematic illustration of the mechanism in the absence of any additional portions of the vaporizer, and Figs. 11C-D show two-dimensional profiles of the
20 mechanism, when the mechanism is, respectively, in its non-active and active configurations.

For some applications, the capsule-transfer-mechanism of the vaporizer is configured to push button 132. For example, a rotatable capsule-transfer-mechanism (as shown in Fig. 2A) may be configured to automatically press against button 132, during the
25 course of its rotation. In response to the button being pushed, electrodes 48 pivot about the hinges 130 such that the electrodes are (a) moved closer to the mesh of the capsule (e.g., in the upward direction, in the example shown), and/or (b) moved along the mesh of the capsule (e.g., in a sliding motion) while the electrodes are in contact the with mesh. The transition of the mechanism resulting from button 132 being pushed is shown in the
30 transition from Fig. 11C to Fig. 11D.

Referring now to Figs. 12A-B, for some applications, a different type of hinge-based electrode-movement mechanism 120 is used. In the example shown in Figs. 12A-B,

in response to the user pushing a button 140 downward, a hinge 142 rotates, thereby causing electrode 48 to move upward toward the lower mesh of a capsule. Alternatively or additionally, a spring (not shown) is configured to push button 140 downward automatically, and the user actively releases button 140, for example, in order to release
5 the capsule. Fig. 12A shows the mechanism disposed within a portion of vaporizer 20, and Fig. 12B is a three-dimensional schematic illustration of the mechanism in the absence of any additional portions of the vaporizer. For some applications, button 140 is additionally configured to cause the vaporizer to operate by being pushed. For example, button 140 may be configured to switch on an operating switch, by being pushed, which may cause
10 the control circuitry to heat the meshes of the capsule using techniques as described herein.

For some applications, mechanisms as described with reference to Figs. 10A-12B are used for enhancing contact between the electrodes and the mesh of a capsule. Alternatively or additionally, techniques are used in order to ensure that a proper electrical connection was made between the electrodes and the meshes of the capsule. For example,
15 the control circuitry may measure the resistance of the mesh of the capsule, in response to current being driven into the mesh. In response to the resistance exceeding a threshold resistance, the control circuitry may determine that there is a problem with the electrical connection between the electrodes and the meshes, and may generate an indication in response thereto. Alternatively or additionally, the control circuitry may drive a small
20 pulse of current into a mesh of the capsule and measure the resultant temperature increase of the capsule. In response to the temperature increase being lower than a threshold temperature, the control circuitry may determine that there is a problem with the electrical connection between the electrode and the mesh, and may generate an indication in response thereto.

Reference is now made to Figs. 13A-C, which are schematic illustrations of a vaporizer 150 that is configured to automatically extract a given volumetric dose of plant material 82 (which, as described hereinabove, contains an active ingredient) from a mass of the plant material that is disposed in the vaporizer (e.g., in a receptacle 152 of the vaporizer), in accordance with some applications of the present invention. Typically, the
30 mass of plant material contains a plurality of volumetric doses of the plant material disposed in a single body, and is not separated into volumetric doses (e.g., by volumetric doses being disposed inside respective, individual capsules, as described hereinabove).

For example, as shown in Fig 13B, which shows a cross-sectional view of receptacle 152, a cigarette 154 containing the plant material may be placed inside the receptacle.

Vaporizer 150 typically includes an extraction mechanism 156. In response to a user activating the extraction mechanism, the extraction mechanism is configured to
5 extract a given volumetric dose of the plant material from the mass of plant material. For example, as shown in Figs. 13A-C, the extraction mechanism may include a button 158 and a blade 160. When the button is pushed by the user, this causes the blade to rotate and to cut the volumetric dose from the mass of plant material.

With reference to Fig. 13C, for some application, when button 158 is advanced
10 through distance X1, this imparts a force to a hinge 162 to which the blade is connected, via a spring 164. The force causes the hinge to rotate such that the blade rotates and cuts the volumetric dose from the mass of plant material. In the example and orientation of the vaporizer shown in Fig. 13C, advancement of the button through distance X1 would cause the blade to rotate in the counter-clockwise direction toward a volumetric-dose-
15 accommodating receptacle 166. Typically, subsequent to extracting the volumetric dose of the plant material, the blade supports the underside of the volumetric dose within receptacle 166.

Further advancement of button 158 typically causes the extracted volumetric dose to advance to a surface 168, which acts as a vaporization location as described
20 hereinabove. A heating element is configured to vaporize the at least one active ingredient of the volumetric dose of the plant material by heating the surface while the volumetric dose is disposed upon the surface. Typically, surface 168 is a mesh, which is heated using control circuitry which drives a current into the mesh via one or more electrodes, as described hereinabove. For some applications, an upper mesh 170 is disposed above the
25 extracted volumetric dose, and is heated in a similar manner. For some applications, other techniques for heating the plant material (e.g., as described hereinabove) are used. For some applications, a sensor is used to monitor the temperature of the plant material. For example, an optical temperature sensor (e.g., an infrared temperature sensor) as described hereinabove may be used. For some applications, a two step process is used for heating
30 the plant material, as described hereinabove.

While the active ingredient is being vaporized, a user typically inhales air via an airway tube 172 and via a mouthpiece 174. The air passes through the plant material, and

vapor from the vaporized plant material enters the air. For some applications, subsequent to the heating of the plant material, button 158 is further advanced. This pushes the used volumetric dose of plant material into a waste receptacle 176. Subsequently, button 158 is retracted (manually or automatically) to its starting position. A spring 178 then pushes the
5 next volumetric dose of the plant material into position to be cut by blade 160. For some applications, the spring pushes a pushing element 180 against the underside of cigarette 154, which contains the plant material.

For some applications, button 158 is additionally configured to cause the vaporizer to operate by being pushed. For example, button 158 may be configured to switch on an
10 operating switch by being pushed, which may cause the control circuitry to heat the meshes of the capsule using techniques as described herein. (It is noted that, although the control circuitry of vaporizer 150 is not shown, control circuitry such as that shown in Fig. 14A is typically housed inside the housing of vaporizer 150.)

Reference is now made to Figs. 14A-C, which are schematic illustrations of a
15 vaporizer 182 that is configured to automatically extract a given volumetric dose of plant material 82 from a mass of the plant material (e.g., cigarette 154) that is disposed in the vaporizer (e.g., in a receptacle 183 of the vaporizer), in accordance with some applications of the present invention. Vaporizer 182 is generally similar to vaporizer 150 described with reference to Figs. 13A-C, except for the differences described below.

Vaporizer 182 typically includes an extraction mechanism 184. In response to a
20 user activating the extraction mechanism, the extraction mechanism is configured to extract a given volumetric dose from the mass of plant material. For example, as shown in Figs. 14A-C, the vaporizer may include a button 185 and a blade 186. When the button is pushed by the user, this causes the blade to advance and to cut a volumetric dose from the
25 mass of plant material. Further pushing of the button pushes the volumetric dose above a surface 187, which acts as a vaporization location, as described hereinabove. A heating element is configured to vaporize the at least one active ingredient of the volumetric dose of the plant material by heating the surface while the volumetric dose is disposed upon the surface. Typically, surface 187 is a mesh, which is heated using control circuitry 188
30 which drives a current into the mesh via one or more electrodes, as described hereinabove. For some applications, an upper mesh 189 is disposed above the extracted volumetric dose, and is heated in a similar manner. For some applications, other techniques for heating the

plant material (e.g., as described hereinabove) are used. For some applications, a sensor is used to monitor the temperature of the plant material. For example, an optical temperature sensor (e.g., an infrared temperature sensor) 190, as described hereinabove, may be used. For some applications, a two-step process is used for heating the plant material, as described hereinabove.

While the active ingredient is being vaporized, a user typically inhales air via an airway tube 191 and via a mouthpiece 192. The air passes through the plant material and vapor from the vaporized plant material enters the air. Subsequent to the volumetric dose being advanced to surface 187, button 185 is retracted (typically, automatically by return spring 193) to its starting position. A spring 194 then pushes the next volumetric dose of the plant material into position to be cut by blade 186. For some applications the spring pushes a pushing element 195 against the underside of cigarette 154, which contains the plant material. Typically, the used volumetric dose is removed from the surface, the next time that the vaporizer is used, by the next volumetric dose pushing the used volumetric dose off the surface, and into a waste receptacle 196.

For some applications, button 185 is additionally configured to cause the vaporizer to operate by being pushed. For example, as shown button 185 may be configured to push against an operating switch 197, by being pushed, which may cause the control circuitry to heat the meshes of the capsule using techniques as described herein.

It is noted that the applications described with reference to Figs. 13A-C and 14A-C, in accordance with which a volumetric dose of the plant material is extracted from a mass of the plant material, may be combined with any of the applications described hereinabove with reference to any one of the other figures, *mutatis mutandis*. For example, optical temperature sensing (e.g., infrared temperature sensing), and/or a two step heating process as described hereinabove, may be used with the vaporizers shown in Figs. 13A-C and 14A-C.

It will be appreciated by persons skilled in the art that the present invention is not limited to what has been particularly shown and described hereinabove. Rather, the scope of the present invention includes both combinations and subcombinations of the various features described hereinabove, as well as variations and modifications thereof that are not in the prior art, which would occur to persons skilled in the art upon reading the foregoing description.

CLAIMS

1. A method for use with a vaporizer that vaporizes at least one active ingredient of a material, the method comprising:
 - receiving a first input at the vaporizer;
 - 5 in response to receiving the first input, heating the material, in a first heating step;
 - detecting an indication of a temperature of the material;
 - in response to detecting an indication that the temperature of the material is at a first temperature, terminating the first heating step, by withholding causing further temperature increase of the material, the first temperature being less than 95 percent of a
 - 10 vaporization temperature of the active ingredient;
 - subsequently, receiving a second input at the vaporizer; and
 - in response to receiving the second input, heating the material to the vaporization temperature of the active ingredient, in a second heating step.
2. The method according to claim 1, wherein detecting the indication of the temperature of the material comprises detecting the indication of the temperature of the material using an optical temperature sensor.
3. The method according to claim 1, further comprising generating an indication that the first heating step has terminated.
4. The method according to claim 1, wherein terminating the first heating step, by withholding causing further temperature increase of the material comprises preventing pyrolysis of the active ingredient.
5. The method according to claim 1, further comprising, subsequent to the second heating step, in response to detecting that no air has been inhaled from the vaporizer for a given time period, reducing a temperature of the material to below the vaporization
- 25 temperature of the material.
6. The method according to claim 1, further comprising detecting a rate of air flow through the vaporizer by detecting an indication of an amount of energy required to maintain the temperature of the material constant.
7. The method according to any one of claims 1-6, wherein heating the material in the
- 30 first heating step comprises heating the material at a first heating rate, wherein heating the

material in the second heating step comprises heating the material at a second heating rate, and wherein the first heating rate is greater than the second heating rate.

8. The method according to claim 7, wherein heating the material at the second heating rate comprises heating the material at a rate of less than 50 degrees Celsius per second.
9. The method according to claim 8, wherein heating the material at the rate of less than 50 degrees Celsius per second comprises preventing pyrolysis of the active ingredient.
10. The method according to claim 8, wherein heating the material at the first heating rate comprises heating the material at a rate of more than 50 degrees Celsius per second.
11. The method according to claim 10, wherein heating the material at the first heating rate comprises heating the material at a rate of more than 100 degrees Celsius per second.
12. The method according to claim 7, wherein heating the material at the first heating rate comprises heating the material at a rate of more than 50 degrees Celsius per second.
13. The method according to claim 12, wherein heating the material at the first heating rate comprises heating the material at a rate of more than 100 degrees Celsius per second.
14. The method according to any one of claims 1-6, wherein receiving the second input comprises detecting that a user is inhaling from the vaporizer.
15. The method according to claim 14, wherein detecting that the user is inhaling from the vaporizer comprises detecting the indication of the temperature of the material.
16. The method according to claim 14, wherein detecting that the user is inhaling from the vaporizer comprises detecting an indication of an amount of energy required to maintain the temperature of the material constant.
17. The method according to any one of claims 1-6, wherein the material includes cannabis and wherein terminating the first heating step comprises withholding causing further temperature increase of the material in response to detecting an indication that the temperature of the material has reached a temperature that is less than 170 degrees Celsius.
18. The method according to claim 17, wherein terminating the first heating step comprises withholding causing further temperature increase of the material in response to

detecting an indication that the temperature of the material has reached a temperature that is less than 160 degrees Celsius.

19. The method according to any one of claims 1-6, wherein detecting the indication of the temperature of the material comprises detecting a temperature of a capsule in which the material is housed.

20. The method according to claim 19, wherein the capsule includes a metallic mesh, and wherein detecting the temperature of the capsule comprises detecting electrical resistance of the mesh.

21. Apparatus for use with a material that includes at least one active ingredient, the apparatus comprising:

a vaporizer configured to vaporize the active ingredient of the material, the vaporizer comprising:

a heating element configured to heat the material;

a temperature sensor configured to detect an indication of a temperature of the material; and

control circuitry configured to:

receive a first input;

in response to receiving the first input, drive the heating element to heat the material at a first heating rate, in a first heating step;

in response to receiving, from the temperature sensor, an indication that the temperature of the material is at a first temperature, terminate the first heating step, by withholding causing further temperature increase of the material by the heating element, the first temperature being less than 95 percent of a vaporization temperature of the active ingredient;

subsequently, receive a second input at the vaporizer; and

in response to receiving the second input, drive the heating element to heat the material to the vaporization temperature of the active ingredient at a second heating rate that is less than the first heating rate, in a second heating step.

22. The apparatus according to claim 21, wherein the control circuitry is configured to be removed from the vaporizer and to be coupled to a second vaporizer.

23. The apparatus according to claim 21, wherein the temperature sensor comprises an optical temperature sensor.
24. The apparatus according to claim 21, wherein the control circuitry is configured to generate an indication that the first heating step has terminated.
- 5 25. The apparatus according to claim 21, wherein the control circuitry by terminating the first heating step, by withholding causing further temperature increase of the material, is configured to prevent pyrolysis of the active ingredient.
26. The apparatus according to claim 21, wherein the control circuitry is configured, subsequent to the second heating step, in response to receiving an indication that no air has
10 been inhaled from the vaporizer for a given time period, to reduce a temperature of the material to below the vaporization temperature of the material.
27. The apparatus according to claim 21, wherein the control circuitry is configured to detect a rate of air flow through the vaporizer by receiving an indication of an amount of energy required to maintain the temperature of the material constant.
- 15 28. The apparatus according to any one of claims 21-27, wherein the control circuitry is configured to drive the heating element to heat the material at the first heating rate by driving the heating element to heat the material at a rate of more than 50 degrees Celsius per second.
29. The apparatus according to claim 28, wherein the control circuitry is configured to
20 drive the heating element to heat the material at the first heating rate by driving the heating element to heat the material at a rate of more than 100 degrees Celsius per second.
30. The apparatus according to any one of claims 21-27, wherein the control circuitry is configured to drive the heating element to heat the material at the second heating rate by driving the heating element to heat the material at a rate of less than 50 degrees Celsius per
25 second.
31. The apparatus according to claim 30, wherein the control circuitry by driving the heating element to heat the material at the rate of less than 50 degrees Celsius per second is configured to prevent pyrolysis of the active ingredient.

32. The apparatus according to claim 30, wherein the control circuitry is configured to drive the heating element to heat the material at the first heating rate by driving the heating element to heat the material at a rate of more than 50 degrees Celsius per second.
33. The apparatus according to claim 32, wherein the control circuitry is configured to drive the heating element to heat the material at the first heating rate by driving the heating element to heat the material at a rate of more than 100 degrees Celsius per second.
34. The apparatus according to any one of claims 21-27, wherein the control circuitry is configured to receive the second input by detecting that a user is inhaling from the vaporizer.
35. The apparatus according to claim 34, wherein the control circuitry is configured to detect that the user is inhaling from the vaporizer by receiving an indication of the temperature of the material from the temperature sensor.
36. The apparatus according to claim 34, wherein the control circuitry is configured to detect that the user is inhaling from the vaporizer by receiving an indication of an amount of energy required to maintain the temperature of the material constant.
37. The apparatus according to any one of claims 21-27, wherein the material includes cannabis and wherein the control circuitry is configured to terminate the first heating step by withholding causing further temperature increase of the material in response to receiving an indication that the temperature of the material has reached a temperature that is less than 170 degrees Celsius.
38. The apparatus according to claim 37, wherein the control circuitry is configured to terminate the first heating step by withholding causing further temperature increase of the material in response to receiving an indication that the temperature of the material has reached a temperature that is less than 160 degrees Celsius.
39. The apparatus according to any one of claims 21-27, further comprising a capsule configured to house the material, wherein the temperature sensor is configured to detect the indication of the temperature of the material by detecting a temperature of the capsule in which the material is housed.

40. The apparatus according to claim 39, wherein the capsule comprises a metallic mesh, and wherein the temperature sensor is configured to detect the indication of the temperature of the material by detecting electrical resistance of the mesh.

41. The apparatus according to claim 39, further comprising a phase-change material
5 that is coupled to the capsule, the phase-change material being configured to undergo a phase change at a temperature that is below a pyrolysis temperature of the material.

42. The apparatus according to claim 41, wherein the capsule comprises at least one hollow wire, and the phase-change material is housed inside the hollow wire.

43. Apparatus comprising:

10 a vaporizer shaped to define at least first and second receptacles, the vaporizer comprising:

a plurality of capsules, each of the capsules comprising a material that contains an active ingredient, the first and second receptacles each being shaped to house the plurality of capsules in stacked configurations;

15 a heating element configured, while each of the capsules is disposed at a vaporization location within the vaporizer, to cause the active ingredient of the material within the capsule to become at least partially vaporized by individually heating the capsule; and

20 a capsule-transfer mechanism configured to individually transfer each of the capsules from the first receptacle to the vaporization location and from the vaporization location to the second receptacle.

44. The apparatus according to claim 43, wherein the capsule-transfer mechanism comprises a rotating capsule-transfer mechanism, configured to transfer the capsules by rotating.

25 45. The apparatus according to claim 43, wherein the first and second receptacles and the vaporization location are linearly aligned with each other, and wherein the capsule-transfer mechanism comprises a linear capsule-transfer mechanism, configured to move each of the capsules by moving linearly.

30 46. The apparatus according to any one of claims 43-45, wherein the heating element comprises one or more electrodes configured to heat the capsules via resistive heating, by driving an electrical current into the portion of the capsule.

47. The apparatus according to claim 46, wherein each of the capsules comprises one or more metallic meshes, and wherein the one or more electrodes are configured to heat the capsules by driving the electrical current into the one or more metallic meshes of the capsule.

5 48. The apparatus according to any one of claims 43-45, wherein a width of the vaporizer is less than 9 cm.

49. The apparatus according to claim 48, wherein a depth of the vaporizer is less than 6 cm.

10 50. The apparatus according to claim 49, wherein a height of the vaporizer is less than 20 cm.

51. A method comprising:

providing a vaporizer shaped to define at least first and second receptacles, a plurality of capsules being housed in a stacked configuration inside the first receptacle, and each of the capsules including a material that contains an active ingredient;

15 using a capsule-transfer mechanism individually transferring a first one of the capsules from the first receptacle to a vaporization location within the vaporizer;

when the first capsule is disposed at the vaporization location within the vaporizer, causing the active ingredient within the material within the first capsule to become at least partially vaporized by individually heating the capsule; and

20 using the capsule-transfer mechanism individually transferring the first capsule from vaporization location to the second receptacle, the second receptacle being configured to house a plurality of the capsules in a stacked configuration.

25 52. The method according to claim 51, wherein the capsule-transfer mechanism includes a rotating capsule-transfer mechanism, and wherein transferring the first one of the capsules from the first receptacle to the vaporization location comprises rotating the capsule-transfer mechanism.

30 53. The method according to claim 51, wherein the first and second receptacles and the vaporization location are linearly aligned with each other, wherein the capsule-transfer mechanism includes a linear capsule-transfer mechanism, and wherein transferring the first one of the capsules from the first receptacle to the vaporization location comprises moving the capsule-transfer mechanism linearly.

54. The method according to any one of claims 51-53, wherein heating the capsules comprises heating the capsules via resistive heating, by driving an electrical current into a portion of the capsule.
55. The method according to claim 54, wherein each of the capsules includes one or
5 more metallic meshes, and wherein driving the electrical current into the portion of the capsule comprises driving the electrical current into the one or more metallic meshes of the capsule.
56. The method according to any one of claims 51-53, wherein providing the vaporizer comprises providing the vaporizer, a width of the vaporizer being less than 9 cm.
- 10 57. The method according to claim 56, wherein providing the vaporizer comprises providing the vaporizer, a depth of the vaporizer being less than 6 cm.
58. The method according to claim 57, wherein providing the vaporizer comprises providing the vaporizer, a height of the vaporizer being less than 20 cm.
59. Apparatus comprising:
15 a vaporizer comprising:
at least one capsule comprising:
upper and lower meshes; and
a given amount of a material housed between the upper and lower
meshes, the material containing at least one active ingredient;
20 control circuitry; and
first, second, third and fourth electrodes,
the control circuitry being configured to vaporize the at least one active
ingredient of the material by:
driving a current from the first electrode to the second electrode via
25 the lower mesh, and
driving a current from the third electrode to the fourth electrode via
the upper mesh.
60. A method comprising:

providing a capsule that includes upper and lower meshes, and a given amount of a material housed between the upper and lower meshes, the material containing at least one active ingredient; and

vaporizing the at least one active ingredient of the material by:

5 driving a current from a first electrode to a second electrode via the lower mesh, and

driving a current from a third electrode to a fourth electrode via the upper mesh.

61. Apparatus comprising:

10 a vaporizer comprising:

at least one capsule, the capsule comprising a material that contains at least one active ingredient;

15 a heating element configured, to cause the active ingredient within the material within the capsule to become at least partially vaporized by heating the capsule; and

a vibrator configured to vibrate the capsule.

62. The apparatus according to claim 61, wherein the vibrator comprises a vibrator selected from the group consisting of: a vibration motor, a piezo-electric crystal, a sonic vibrator, and an ultrasonic vibrator.

20 63. The apparatus according to claim 61, wherein the vibrator is configured to increase airflow through the capsule by vibrating the capsule.

64. The apparatus according to claim 61, wherein the vibrator is configured to mix the material within the capsule by vibrating the capsule.

25 65. The apparatus according to claim 61, wherein the vibrator is configured to increase a uniformity of heating of the material within the capsule by vibrating the capsule.

66. A method comprising:

providing a vaporizer that includes at least one capsule, the capsule including a material that contains at least one active ingredient;

30 activating a heating element within the vaporizer to cause the active ingredient within the material to become at least partially vaporized by heating the capsule; and

activating a vibrator within the vaporizer to vibrate the capsule.

67. The method according to claim 66, wherein the vibrator includes a vibrator selected from the group consisting of: a vibration motor, a piezo-electric crystal, a sonic vibrator, and an ultrasonic vibrator, and wherein activating the vibrator comprises activating the selected vibrator.

68. The method according to claim 66, wherein activating the vibrator comprises increasing airflow through the capsule by activating the vibrator to vibrate the capsule.

69. The method according to claim 66, wherein activating the vibrator comprises mixing the material within the capsule by activating the vibrator to vibrate the capsule.

70. The method according to claim 66, wherein activating the vibrator comprises increasing a uniformity of heating of the material within the capsule by activating the vibrator to vibrate the capsule.

71. Apparatus comprising:

a vaporizer shaped to define at least one receptacle, the vaporizer comprising:

a plurality of capsules, each of the capsules comprising a material that contains an active ingredient, the receptacle being shaped to house the plurality of capsules in a stacked configuration, upon a supporting surface;

a screw, the supporting surface being threadedly coupled to the screw, such that, in response to the screw rotating in a given direction, the supporting surface is configured to push one of the capsule out of an opening of the receptacle by the supporting surface advancing toward the opening.

72. The apparatus according to claim 71, further comprising a capsule-transfer mechanism configured to individually transfer each of the capsules from the opening of the receptacle to a vaporization location at which the vaporizer is configured to vaporize the active ingredient of the material.

73. Apparatus comprising:

a vaporizer comprising:

at least one capsule comprising:

at least one mesh that defines at least a portion of an outer surface of the capsule; and

material housed within the capsule, the material containing at least one active ingredient;

at least one electrode;

control circuitry configured to vaporize the at least one active ingredient of
5 the material by driving a current into the mesh via the electrode; and

an electrode-movement mechanism configured to move the electrode with respect to the mesh.

74. The apparatus according to claim 73, further comprising a coating disposed upon at least a portion of the outer surface of the capsule that is defined by the mesh, wherein the
10 electrode-movement mechanism is configured to cause the electrode to penetrate the coating, by moving the electrode with respect to the mesh.

75. The apparatus according to claim 73, wherein the electrode-movement mechanism comprises a button configured to be pressed by a user, and wherein, the electrode-movement mechanism is configured to move the electrode with respect to the mesh in
15 response to the user pressing the button.

76. The apparatus according to claim 73, wherein the electrode-movement mechanism comprises a hinge.

77. The apparatus according to claim 73, wherein the electrode-movement mechanism is configured to remove a coating from the mesh by moving the electrode with respect to
20 the mesh.

78. The apparatus according to claim 73, wherein the electrode-movement mechanism is configured to cause the electrode to penetrate a coating on the mesh, by moving the electrode with respect to the mesh.

79. The apparatus according to claim 73, wherein the electrode-movement mechanism is configured to slide the electrode across the outer surface of the capsule that is defined by
25 the mesh, while the electrode is in contact with the mesh.

80. The apparatus according to any one of claims 73-79, wherein the electrode is shaped to define a sharp tip.

81. The apparatus according to claim 80, wherein the electrode is shaped to define a
30 blade.

82. Apparatus comprising:

a vaporizer configured to accommodate a mass of material that contains an active ingredient, the vaporizer comprising:

a surface;

5 an extraction mechanism configured, in response to being activated, to extract a given volumetric dose of the material from the mass of material and place the volumetric dose upon the surface; and

10 a heating element configured to vaporize the at least one active ingredient of the volumetric dose of the material by heating the surface while the volumetric dose is disposed upon the surface.

83. The apparatus according to claim 82, wherein the vaporizer is shaped to define at least one receptacle that is configured to accommodate the mass of material.

84. The apparatus according to claim 82, wherein the surface comprises a mesh, and wherein the heating element comprises one or more electrodes and control circuitry, the control circuitry being configured to vaporize the at least one active ingredient of the volumetric dose of the material by driving a current into the mesh via the one or more electrodes.

85. The apparatus according to claim 82, wherein the mass of material comprises a cigarette containing the material, and wherein the extraction mechanism comprises a blade that is configured to extract the given volumetric dose of the material from the mass of material by cutting off a portion of the cigarette.

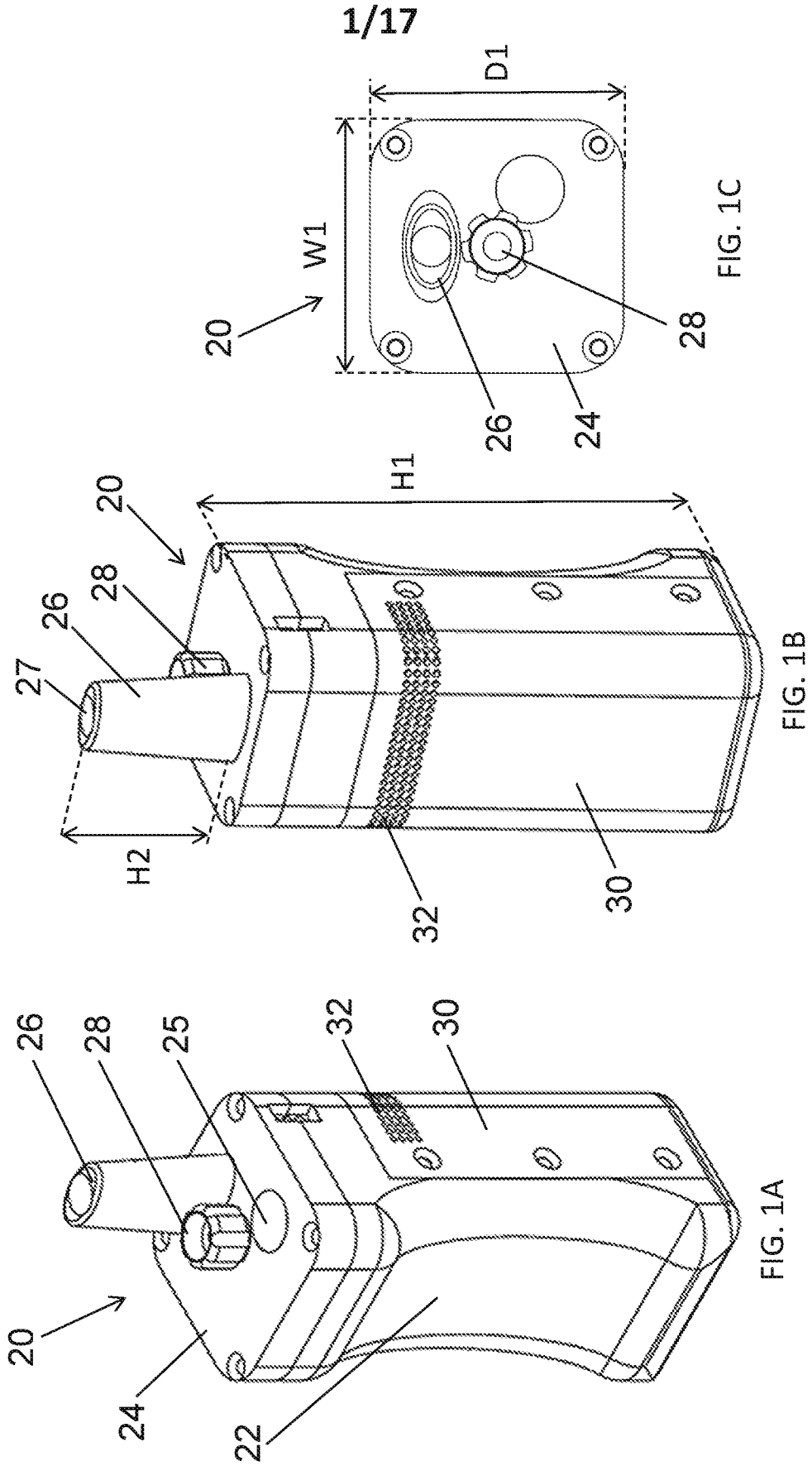

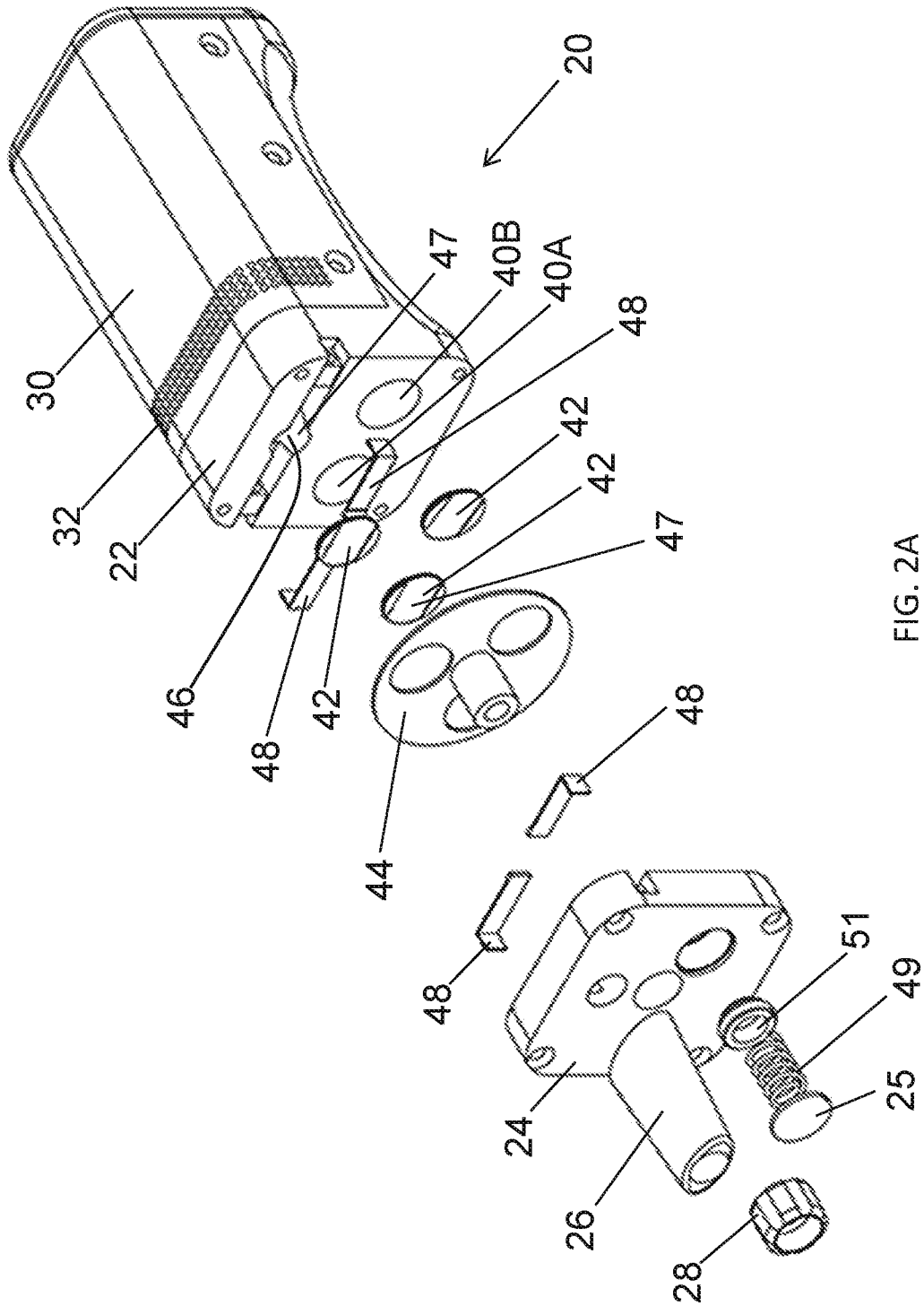

FIG. 2A

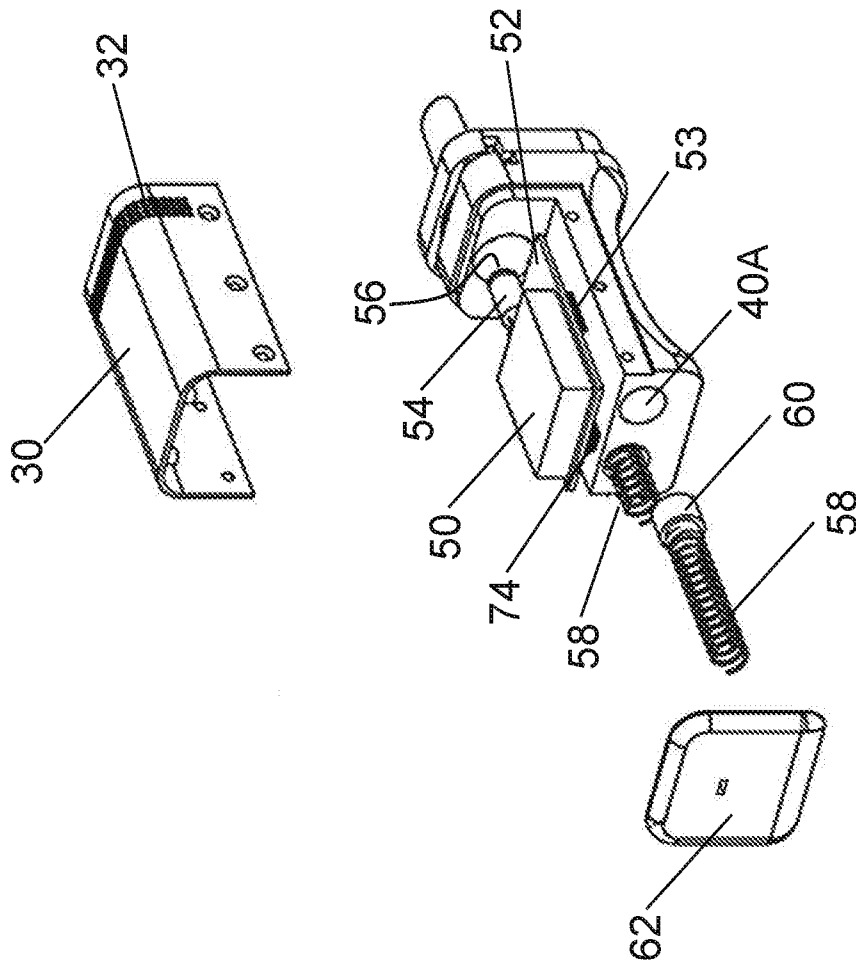

FIG. 2B

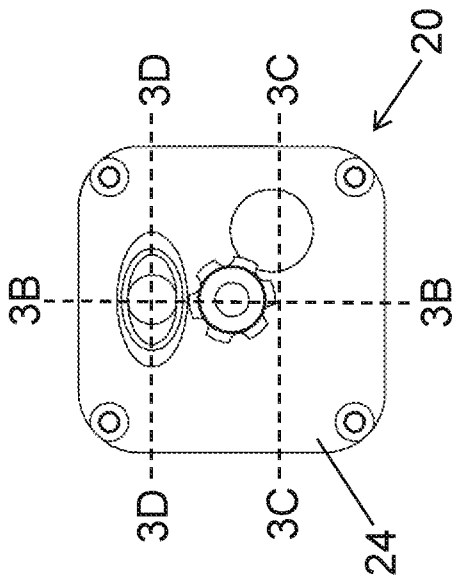

FIG. 3A

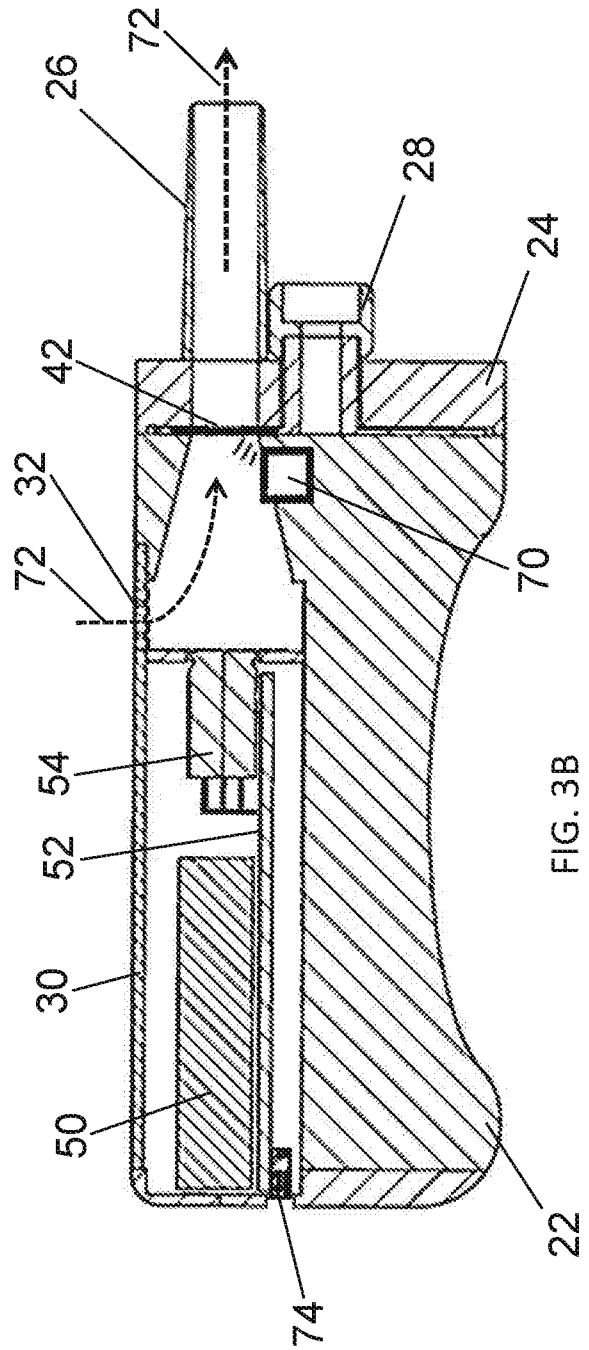
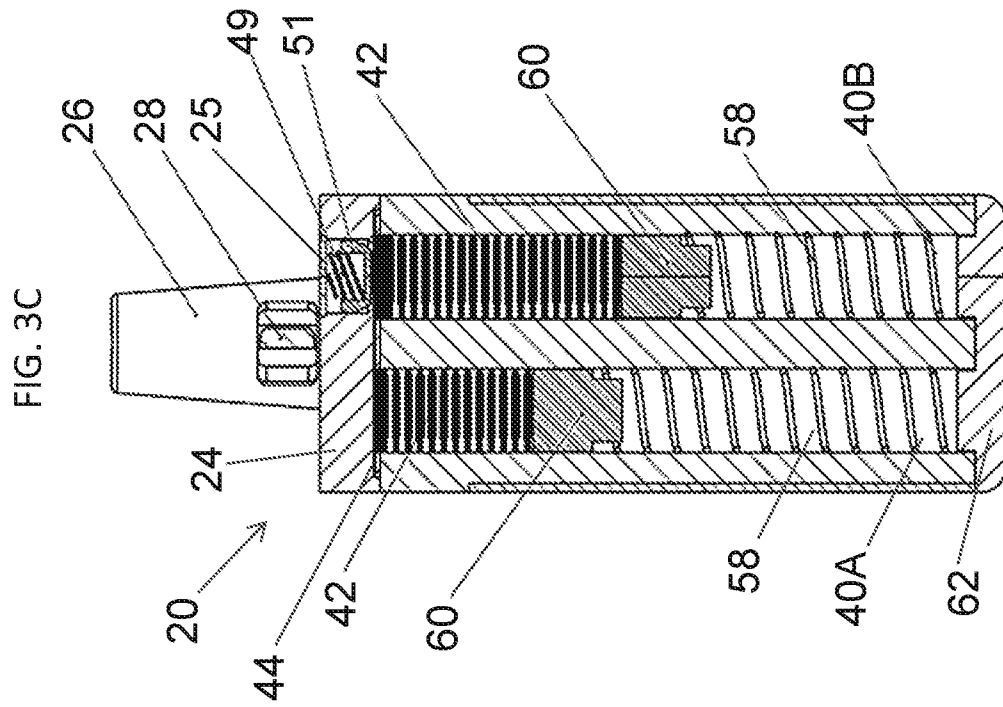
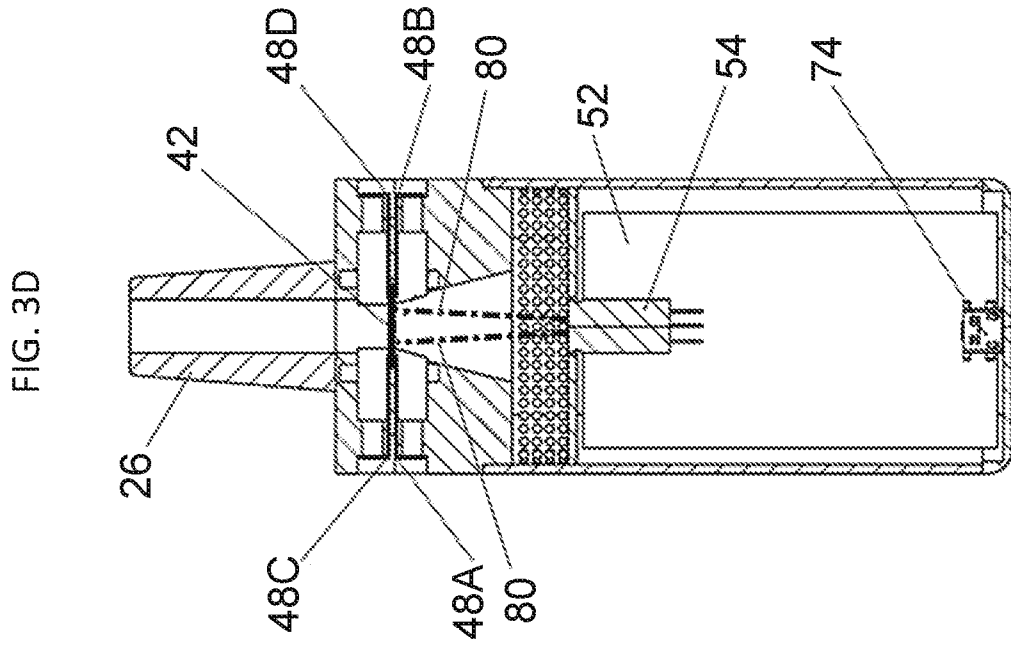

FIG. 3B



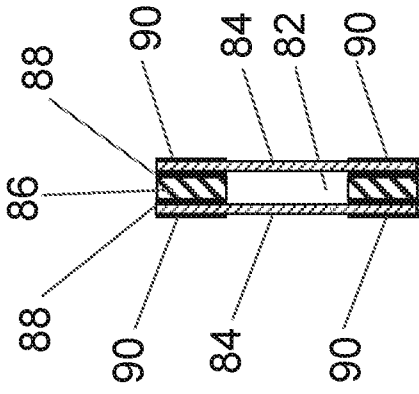
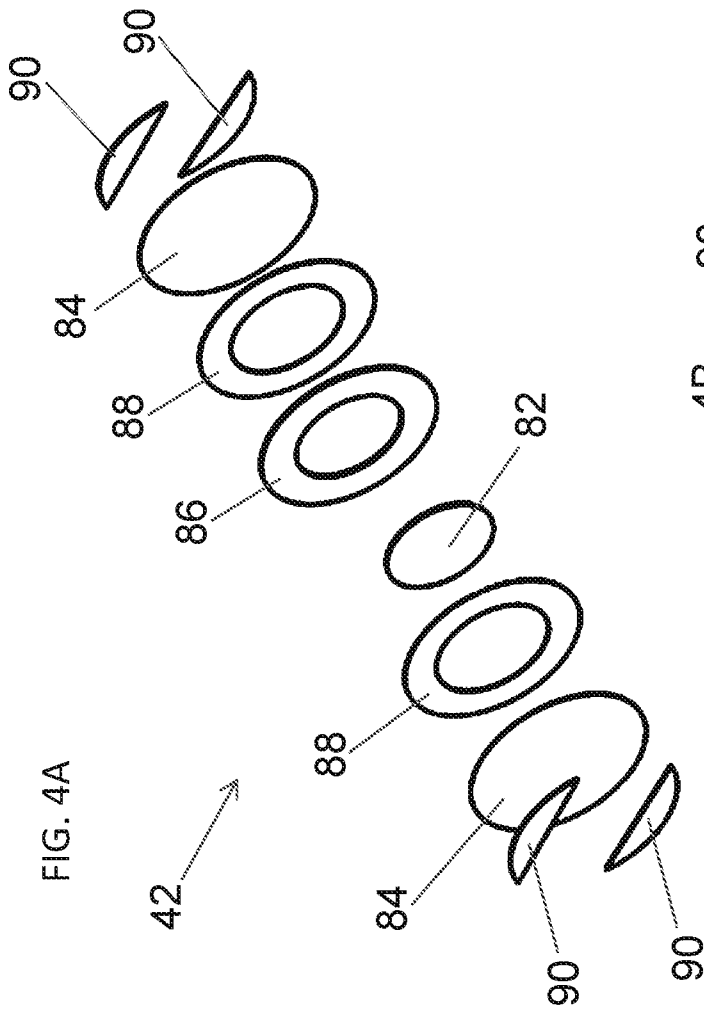

FIG. 4B

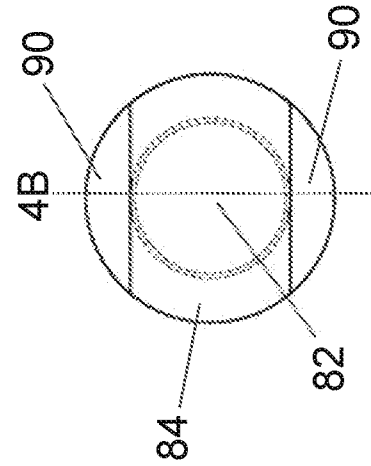

FIG. 4C

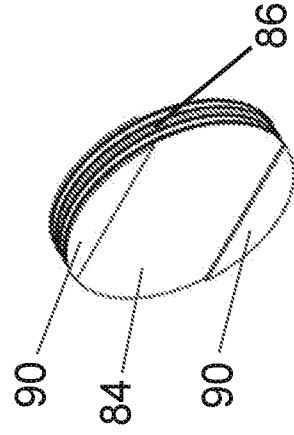

FIG. 4D

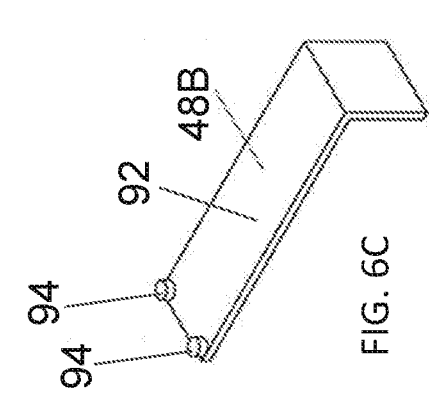

FIG. 6C

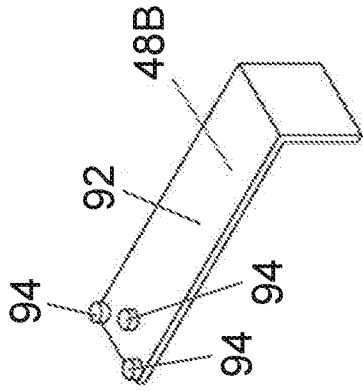

FIG. 6D

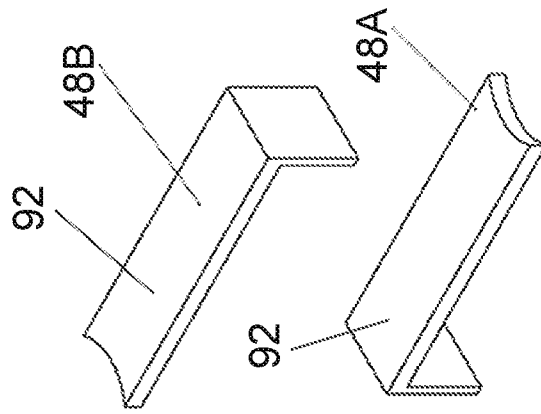

FIG. 6A

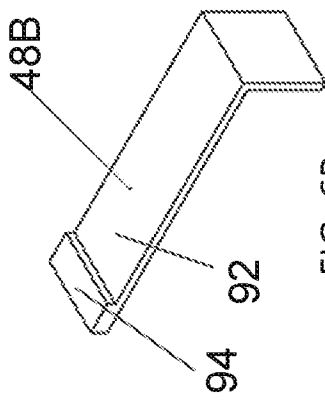

FIG. 6B

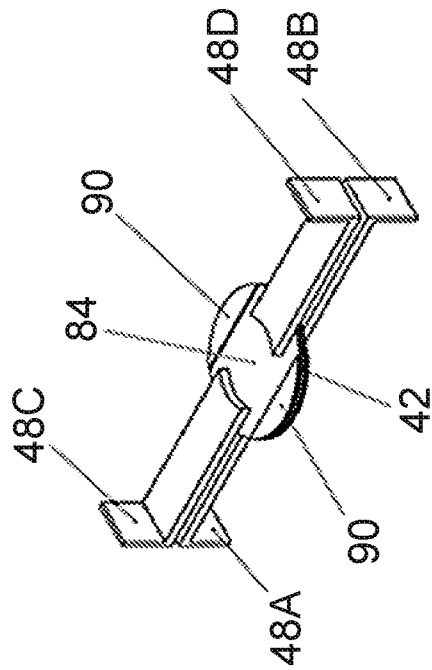

FIG. 5

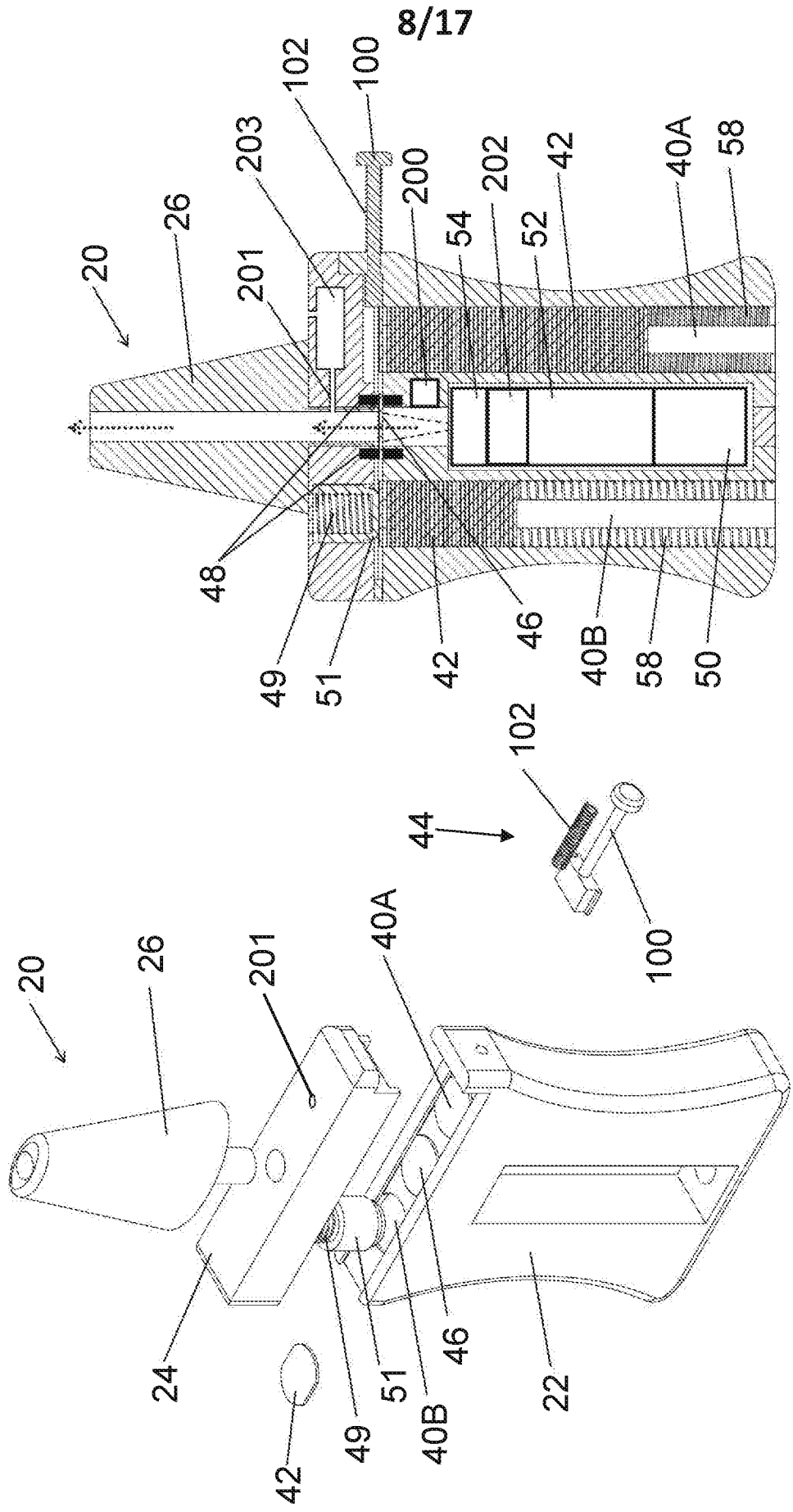
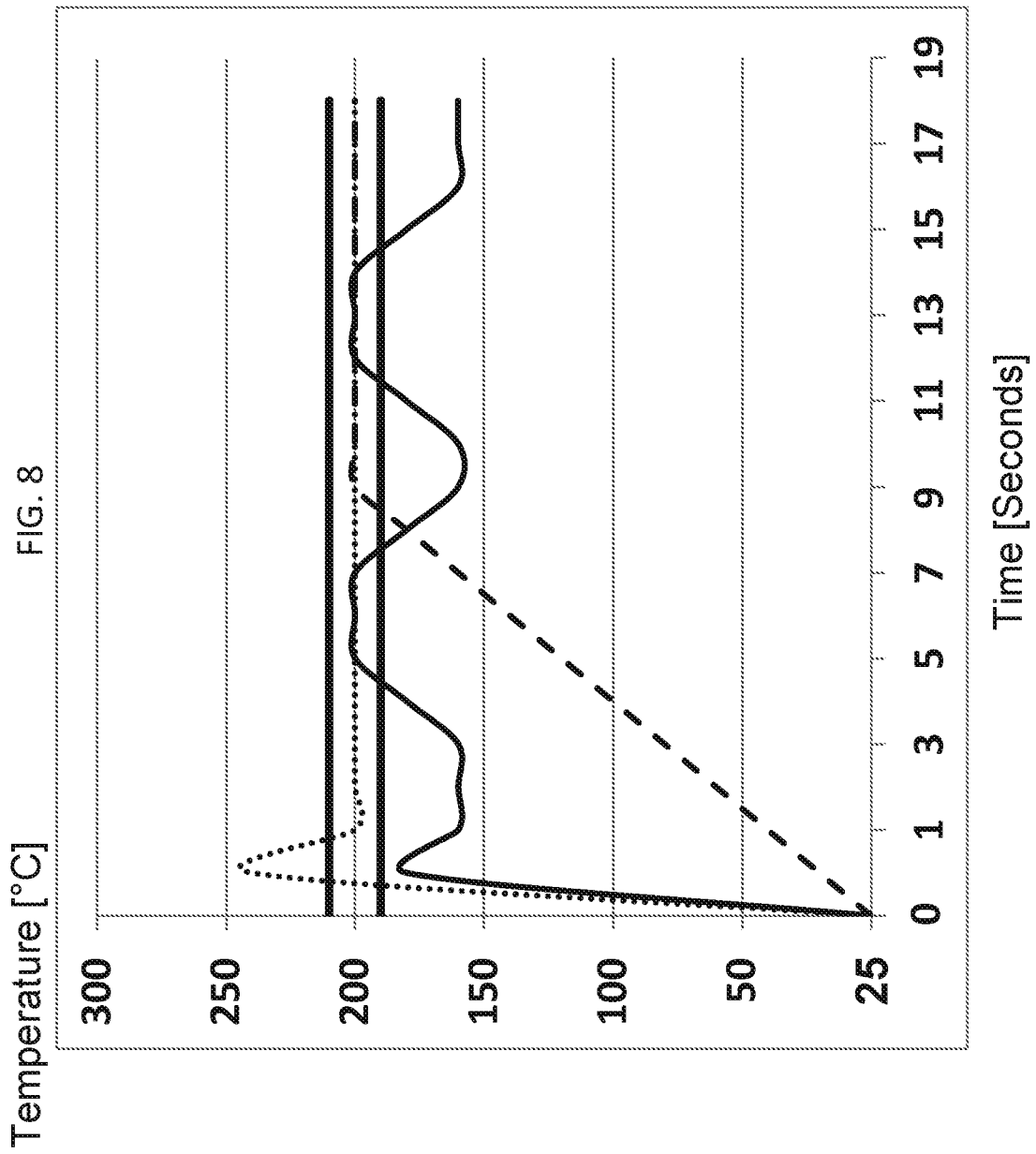

FIG. 7B

FIG. 7A

9/17



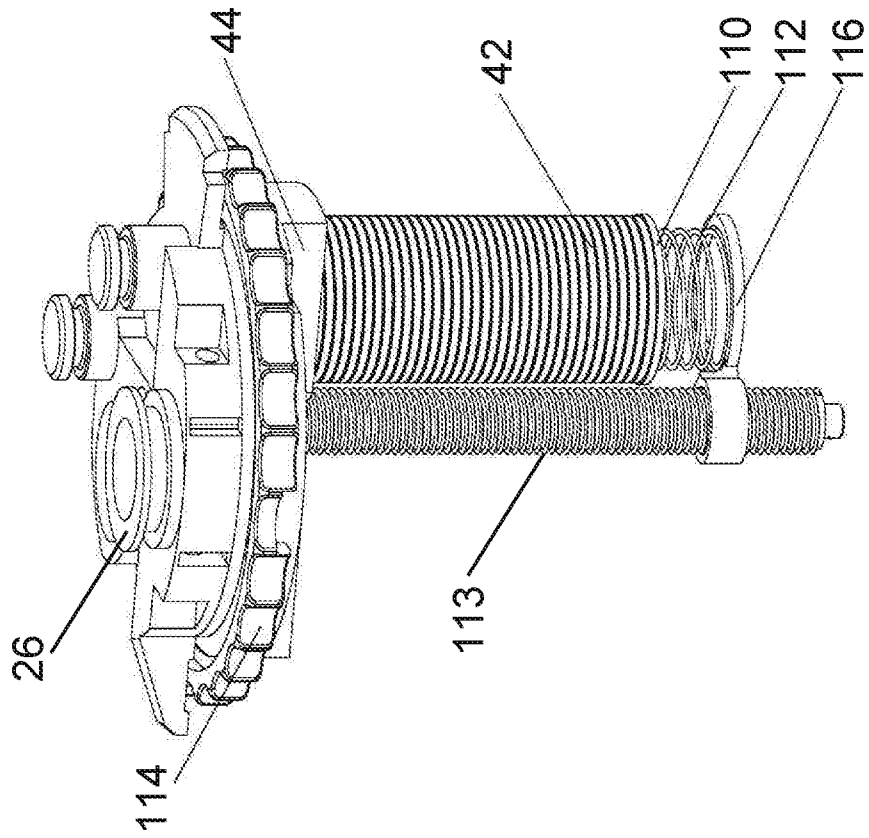

FIG. 9B

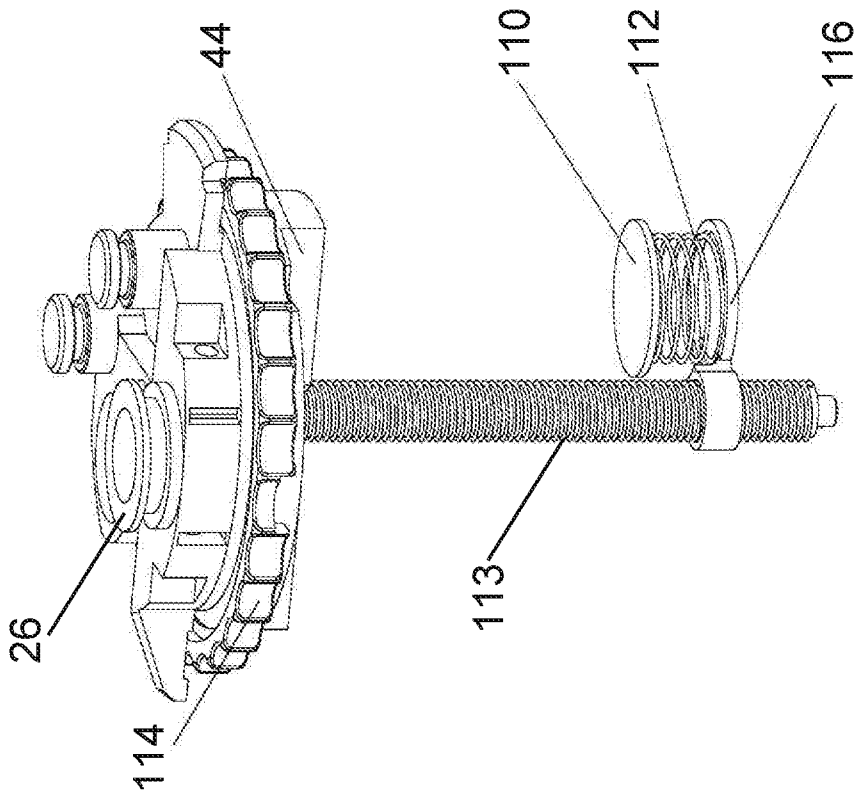

FIG. 9A

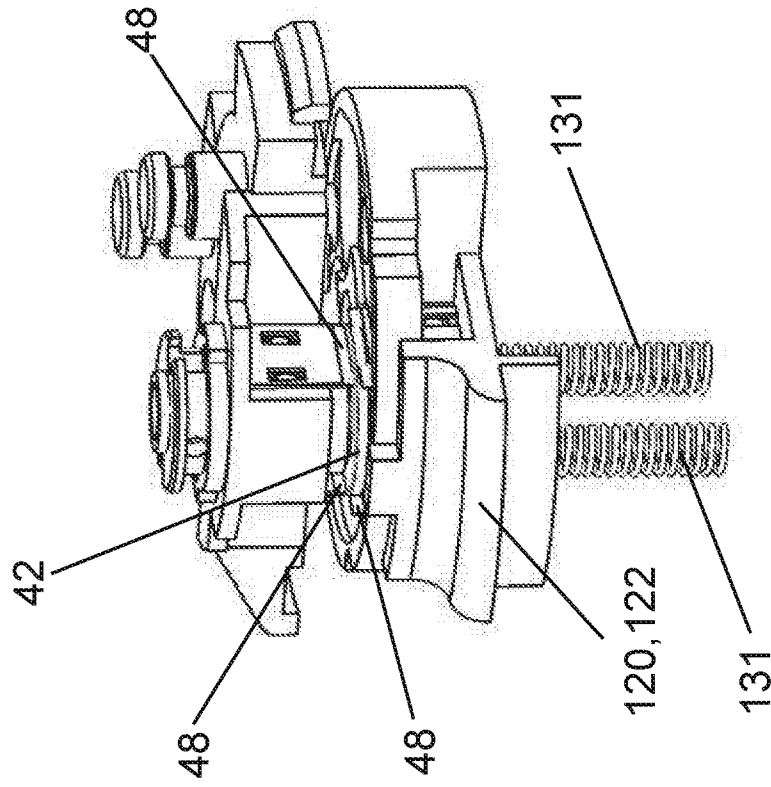

FIG. 10B

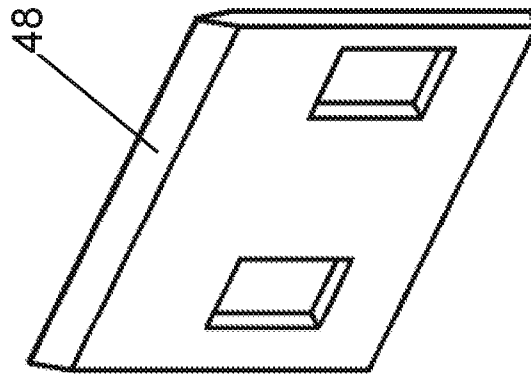

FIG. 10A

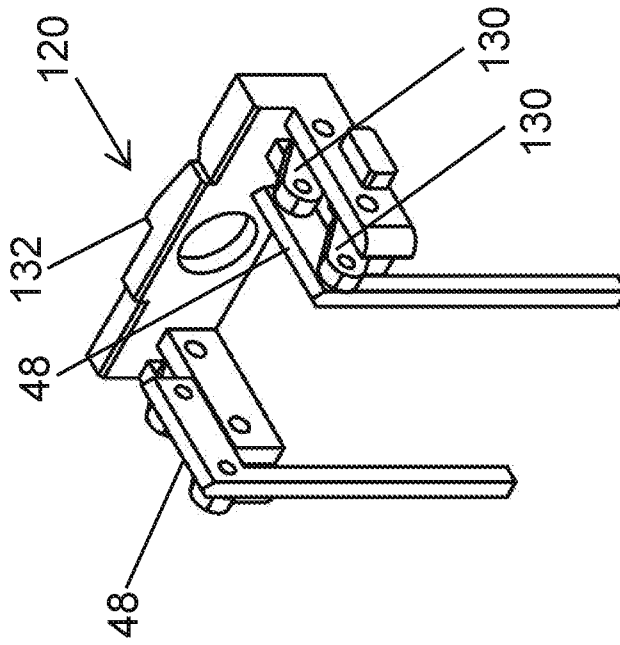

FIG. 11B

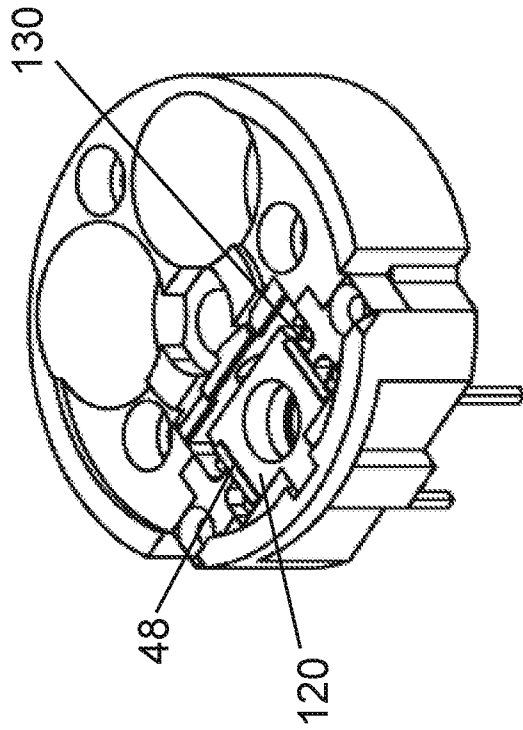

FIG. 11A

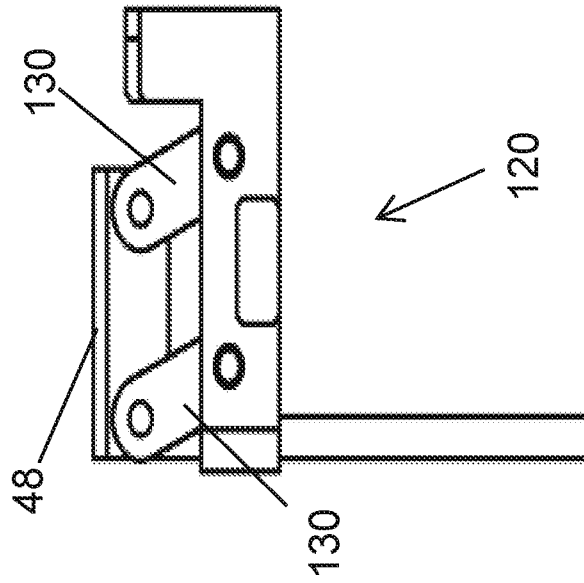

FIG. 11D

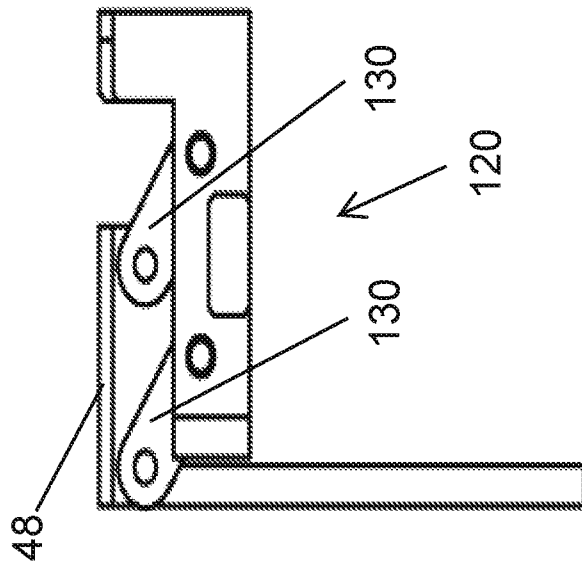

FIG. 11C

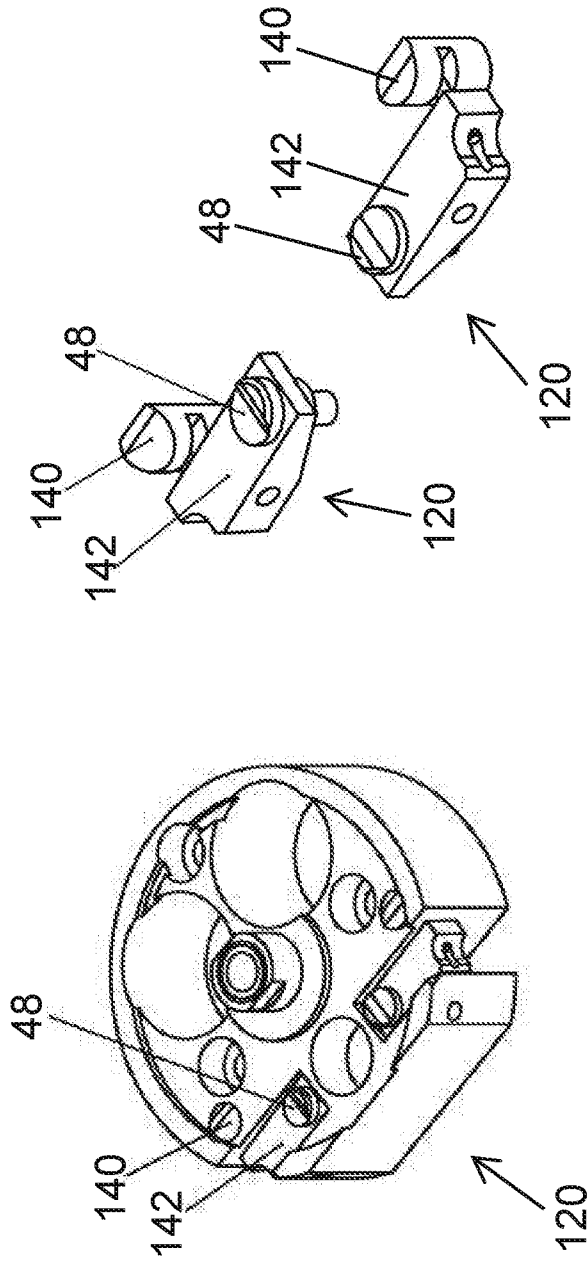

FIG. 12B

FIG. 12A

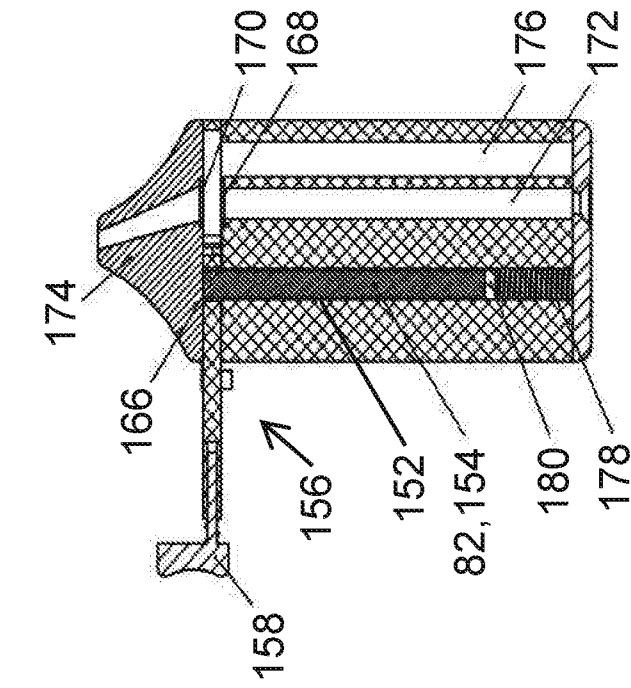

FIG. 13B

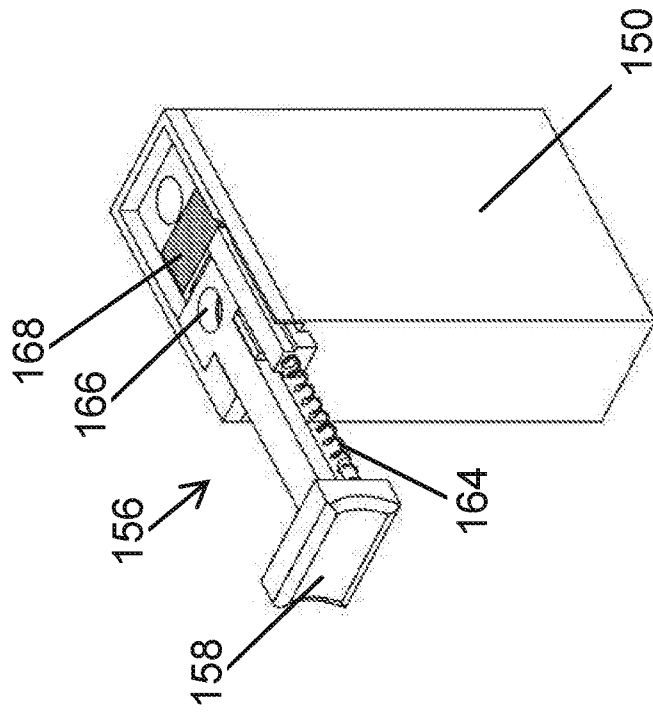

FIG. 13A

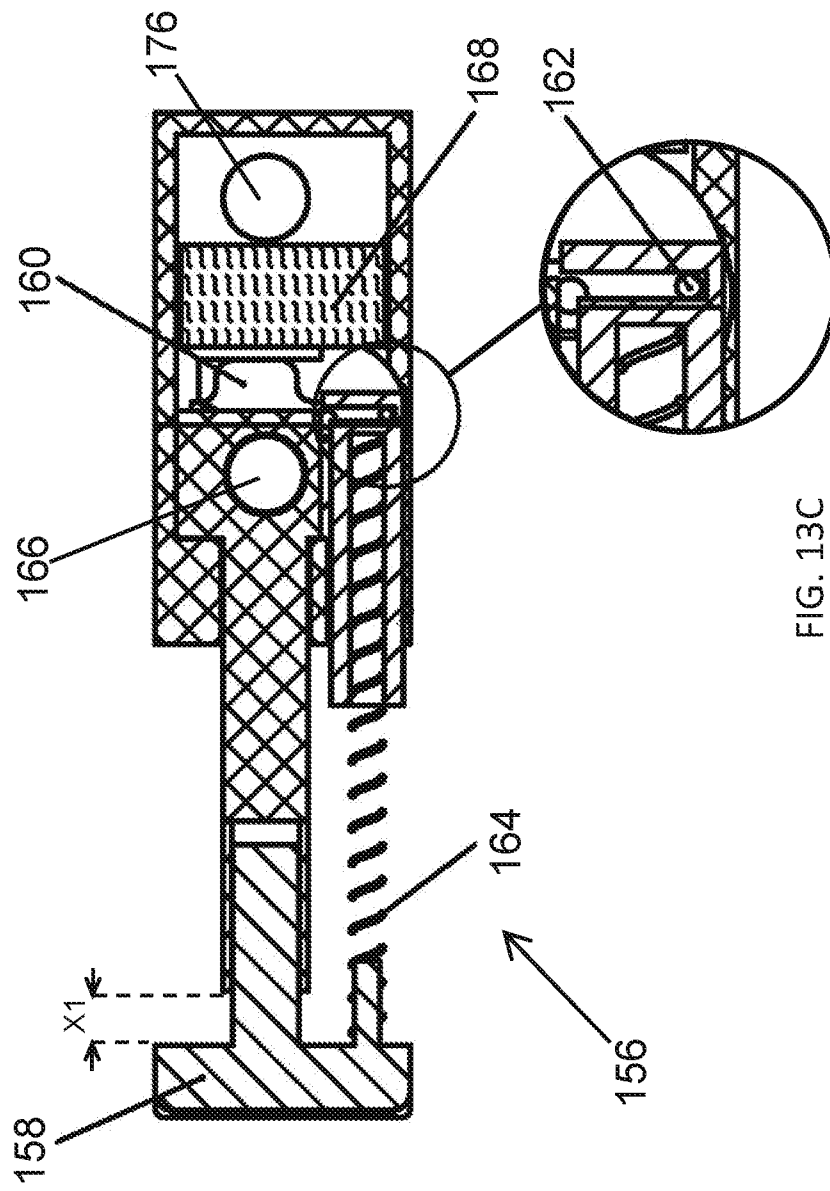
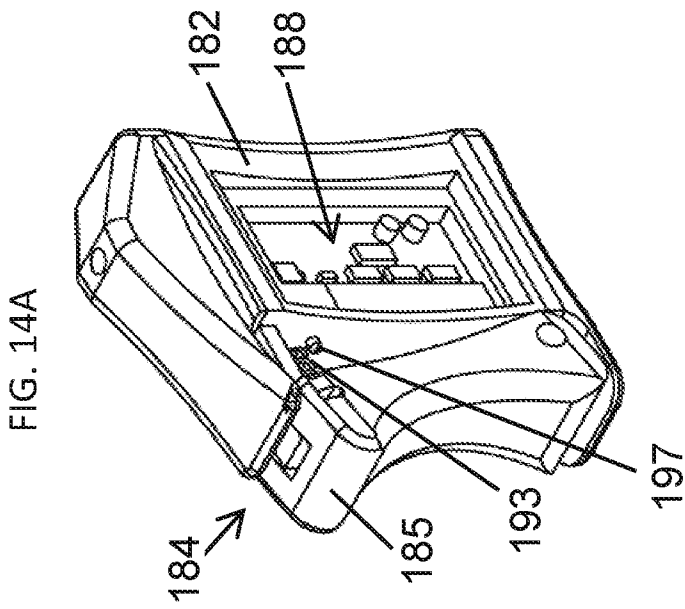
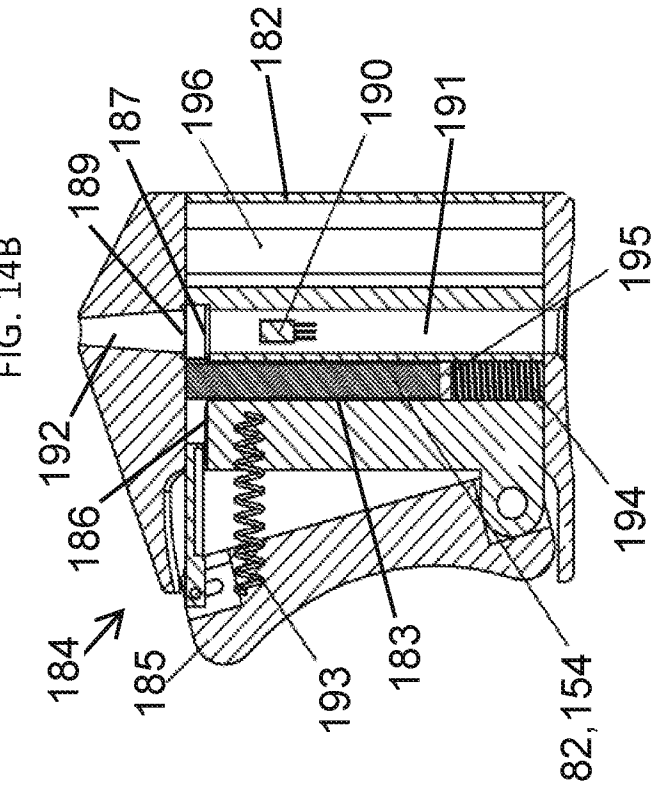

FIG. 13C



INTERNATIONAL SEARCH REPORT

International application No.

PCT/IL2016/050293

A. CLASSIFICATION OF SUBJECT MATTER IPC (2016.01) A61M 15/00, A24F 47/00, G05D 23/00		
According to International Patent Classification (IPC) or to both national classification and IPC		
B. FIELDS SEARCHED		
Minimum documentation searched (classification system followed by classification symbols) IPC (2016.01) A61M, A24F, G05D		
Documentation searched other than minimum documentation to the extent that such documents are included in the fields searched		
Electronic data base consulted during the international search (name of data base and, where practicable, search terms used) Databases consulted: Esp@cenet, Google Patents, Google Scholar, FamPat database Search terms used: Vaporizer, inhalation, temperature, over-shoot, pyrolysis, degradation, cannabis , phase-change material , capsule		
C. DOCUMENTS CONSIDERED TO BE RELEVANT		
Category*	Citation of document, with indication, where appropriate, of the relevant passages	Relevant to claim No.
X	US 2013255702 A1 GRIFITH, JR. D. W. et al. 03 Oct 2013 (2013/10/03) para. [0009],[0014]-[0016],[0019],[0020],[0022],[0047]-[0049],[0053]-[0055],[0057],[0058],[0060],[0062],[0064],[0085],[0086],[0127],[0134],[0145]	1,3-16,21,22,24-27, 34-36
Y		2,17-20,23,37-40
A		41,42
Y	US 4947874 A BROOKS J. L. et al. 14 Aug 1990 (1990/08/14) col. 16 lines 39-40	2,23
Y	US 6095153 A KESSLER S. B. et al. 01 Aug 2000 (2000/08/01) col. 1 lines 7-37, example 2; col. 7 lines 24-29	17-20,37-40
Y	US 2012304990 A1 TODD W. W. 06 Dec 2012 (2012/12/06) abstract , para. [0053]-[0055]	17,18,37,38
<input checked="" type="checkbox"/> Further documents are listed in the continuation of Box C. <input checked="" type="checkbox"/> See patent family annex.		
* Special categories of cited documents: "A" document defining the general state of the art which is not considered to be of particular relevance "E" earlier application or patent but published on or after the international filing date "L" document which may throw doubts on priority claim(s) or which is cited to establish the publication date of another citation or other special reason (as specified) "O" document referring to an oral disclosure, use, exhibition or other means "P" document published prior to the international filing date but later than the priority date claimed "T" later document published after the international filing date or priority date and not in conflict with the application but cited to understand the principle or theory underlying the invention "X" document of particular relevance; the claimed invention cannot be considered novel or cannot be considered to involve an inventive step when the document is taken alone "Y" document of particular relevance; the claimed invention cannot be considered to involve an inventive step when the document is combined with one or more other such documents, such combination being obvious to a person skilled in the art "&" document member of the same patent family		
Date of the actual completion of the international search 31 Jul 2016		Date of mailing of the international search report 02 Aug 2016
Name and mailing address of the ISA: Israel Patent Office Technology Park, Bldg.5, Malcha, Jerusalem, 9695101, Israel Facsimile No. 972-2-5651616		Authorized officer GUTMAN Ariel Telephone No. 972-2-5657816

INTERNATIONAL SEARCH REPORT

International application No.

PCT/IL2016/050293

C (Continuation). DOCUMENTS CONSIDERED TO BE RELEVANT

Category*	Citation of document, with indication, where appropriate, of the relevant passages	Relevant to claim No.
A	US 7186958 B1 NELSON S. G. 06 Mar 2007 (2007/03/06) The whole document	1-42
A	US 4564748 A GUPTON J. 14 Jan 1986 (1986/01/14) Abstarct	1-42
A	US 2010313901 A1 FERNANDO F. et al. 16 Dec 2010 (2010/12/16) abstract	1-42

Box No. III Observations where unity of invention is lacking (Continuation of item 3 of first sheet)

This International Searching Authority found multiple inventions in this international application, as follows:

See extra sheet.

1. As all required additional search fees were timely paid by the applicant, this international search report covers all searchable claims.
2. As all searchable claims could be searched without effort justifying additional fees, this Authority did not invite payment of additional fees.
3. As only some of the required additional search fees were timely paid by the applicant, this international search report covers only those claims for which fees were paid, specifically claims Nos.:
4. No required additional search fees were timely paid by the applicant. Consequently, this international search report is restricted to the invention first mentioned in the claims; it is covered by claims Nos.:
1-42

Remark on Protest

- The additional search fees were accompanied by the applicant's protest and, where applicable, the payment of a protest fee.
- The additional search fees were accompanied by the applicant's protest but the applicable protest fee was not paid within the time limit specified in the invitation.
- No protest accompanied the payment of additional search fees.

INTERNATIONAL SEARCH REPORT
Information on patent family members

International application No. PCT/IL2016/050293
--

Patent document cited search report	Publication date	Patent family member(s)	Publication Date
US 2013255702 A1	03 Oct 2013	US 2013255702 A1	03 Oct 2013
		CN 104349687 A	11 Feb 2015
		EP 2833744 A1	11 Feb 2015
		JP 2015512262 A	27 Apr 2015
		WO 2013148810 A1	03 Oct 2013
US 4947874 A	14 Aug 1990	US 4947874 A	14 Aug 1990
		CN 1045691 A	03 Oct 1990
		DK 442589 D0	07 Sep 1989
		DK 442589 A	09 Mar 1990
		EP 0358002 A2	14 Mar 1990
		EP 0358002 A3	14 Nov 1990
		FI 894224 A	09 Mar 1990
		JP H02124082 A	11 May 1990
		NO 893590 D0	07 Sep 1989
		NO 893590 A	09 Mar 1990
US 6095153 A	01 Aug 2000	US 6095153 A	01 Aug 2000
US 2012304990 A1	06 Dec 2012	US 2012304990 A1	06 Dec 2012
		US 8910630 B2	16 Dec 2014
		AU 2011210371 A1	02 Aug 2012
		AU 2011276504 A1	24 Jan 2013
		AU 2011276505 A1	24 Jan 2013
		CA 2787885 A1	04 Aug 2011
		CA 2804124 A1	12 Jan 2012
		CA 2804124 C	27 May 2014
		CA 2805553 A1	12 Jan 2012
		CA 2805553 C	13 Jan 2015
		CN 102712212 A	03 Oct 2012
		CN 102712212 B	25 Nov 2015

INTERNATIONAL SEARCH REPORT
Information on patent family members

International application No.
PCT/IL2016/050293

Patent document cited search report	Publication date	Patent family member(s)	Publication Date
		CN 103037909 A	10 Apr 2013
		CN 103068425 A	24 Apr 2013
		DK 2531360 T3	19 Jan 2015
		EP 2531360 A1	12 Dec 2012
		EP 2531360 B1	15 Oct 2014
		EP 2585149 A1	01 May 2013
		EP 2588149 A1	08 May 2013
		EP 2588149 A4	20 Aug 2014
		EP 2853414 A2	01 Apr 2015
		EP 2853414 A3	08 Apr 2015
		ES 2527852 T3	30 Jan 2015
		JP 2013518755 A	23 May 2013
		KR 20120117839 A	24 Oct 2012
		MX 2012008870 A	22 Nov 2012
		PT 2531360 E	04 Feb 2015
		RU 2012136381 A	10 Mar 2014
		RU 2557642 C2	27 Jul 2015
		RU 2013103501 A	10 Aug 2014
		RU 2013103502 A	10 Aug 2014
		RU 2015120636 A	27 Dec 2015
		US 2013033099 A1	07 Feb 2013
		US 2013087144 A1	11 Apr 2013
		US 2013233309 A1	12 Sep 2013
		WO 2011092709 A1	04 Aug 2011
		WO 2012006125 A1	12 Jan 2012
		WO 2012006126 A1	12 Jan 2012
US 7186958 B1	06 Mar 2007	US 2007045288 A1	01 Mar 2007
		US 7186958 B1	06 Mar 2007
		US 2007125765 A1	07 Jun 2007

INTERNATIONAL SEARCH REPORT
Information on patent family members

International application No. PCT/IL2016/050293
--

Patent document cited search report	Publication date	Patent family member(s)	Publication Date
US 4564748 A	14 Jan 1986	US 4564748 A	14 Jan 1986
		AU 563079 B2	25 Jun 1987
		AU 2054283 A	03 May 1984
		BE 898116 A1	30 Apr 1984
		BR 8305949 A	05 Jun 1984
		CA 1218730 A	03 Mar 1987
		DE 3338650 A1	03 May 1984
		DE 3338650 C2	27 Apr 1995
		DK 496583 D0	28 Oct 1983
		DK 496583 A	30 Apr 1984
		DK 168938 B1	18 Jul 1994
		ES 526855 D0	16 Aug 1984
		ES 8407220 A1	16 Nov 1984
		FR 2535484 A1	04 May 1984
		FR 2535484 B1	21 Aug 1987
		GB 8329037 D0	30 Nov 1983
		GB 2130401 A	31 May 1984
		GB 2130401 B	28 Jan 1987
		JP S59151967 A	30 Aug 1984
		JP H0438434 B2	24 Jun 1992
		MX 157420 A	21 Oct 1988
		NL 8303735 A	16 May 1984
		NL 192636 B	01 Jul 1997
		NL 192636 C	04 Nov 1997
		SE 8305895 D0	27 Oct 1983
		SE 8305895 L	30 Apr 1984
		SE 458422 B	03 Apr 1989
		ZA 8307869 B	27 Jun 1984
<hr/>			
US 2010313901 A1	16 Dec 2010	US 2010313901 A1	16 Dec 2010
		AU 2010251453 A1	12 Jan 2012

INTERNATIONAL SEARCH REPORT
Information on patent family members

International application No.
PCT/IL2016/050293

Patent document cited search report	Publication date	Patent family member(s)	Publication Date
		AU 2010251453 B2	11 Feb 2016
		CA 2762919 A1	25 Nov 2010
		CN 102438470 A	02 May 2012
		CN 102438470 B	09 Apr 2014
		CO 6480913 A2	16 Jul 2012
		EP 2253233 A1	24 Nov 2010
		EP 2432339 A1	28 Mar 2012
		IL 216215 D0	31 Jan 2012
		JP 2012527222 A	08 Nov 2012
		JP 5670437 B2	18 Feb 2015
		KR 20120027029 A	20 Mar 2012
		KR 20150058569 A	28 May 2015
		MX 2011012355 A	06 Mar 2012
		MY 156781 A	31 Mar 2016
		NZ 596257 A	31 Jan 2014
		RU 2011152199 A	27 Jun 2013
		RU 2531890 C2	27 Oct 2014
		SG 176001 A1	29 Dec 2011
		UA 104628 C2	25 Feb 2014
		US 2016137395 A1	19 May 2016
		WO 2010133342 A1	25 Nov 2010
		ZA 201108180 B	25 Jul 2012

Box No. III Observations where unity of invention is lacking (Continuation of item 3 of first sheet):

* This International Searching Authority found multiple inventions in this international application, as follows:

- | | | |
|---------------|--|---------------------|
| Invention/s 1 | refers to an apparatus (i.e. vaporizer for vaporizing an active ingredient) and a method for use with the apparatus characterized by the controlling of the working temperature controlling, wherein the apparatus comprising a heating element, a temperature sensor and a control circuit. | Claim/s 1-42 |
| Invention/s 2 | refers to an apparatus (i.e. vaporizer for vaporizing an active ingredient) and a method for use with the apparatus characterized by capsules storage and transfers means, wherein the apparatus comprising plurality of capsules, capsules receptacle/s, a heating element, and a capsule transfer mechanism. | Claim/s 43-58,71,72 |
| Invention/s 3 | refers to an apparatus (i.e. vaporizer for vaporizing an active ingredient) and a method for use with the apparatus characterized by a capsule having upper meshes and lower meshes, wherein the apparatus comprising a control circuit and 4 electrodes. | Claim/s 59,60 |
| Invention/s 4 | refers to an apparatus (i.e. vaporizer for vaporizing an active ingredient) and a method for use with the apparatus, wherein the apparatus comprising a capsule, a heating element and a vibrator. | Claim/s 61-70 |
| Invention/s 5 | refers to an apparatus (i.e. vaporizer for vaporizing an active ingredient) characterized by a capsule having mesh, wherein the apparatus comprising a control circuit and moving electrode. | Claim/s 73-81 |
| Invention/s 6 | refers to an apparatus (i.e. vaporizer for vaporizing an active ingredient), wherein the apparatus comprising an extraction mechanism for mass of material and a heating element. | Claim/s 82-85 |