

(19) World Intellectual Property Organization  
International Bureau



(43) International Publication Date  
24 August 2006 (24.08.2006)

PCT

(10) International Publication Number  
**WO 2006/089250 A2**

- (51) International Patent Classification:  
*H04M 1/00* (2006.01)
- (21) International Application Number:  
PCT/US2006/005887
- (22) International Filing Date:  
16 February 2006 (16.02.2006)
- (25) Filing Language: English
- (26) Publication Language: English
- (30) Priority Data:  
60/653,712 16 February 2005 (16.02.2005) US
- (71) Applicant (for all designated States except US): **LOG-ITECH EUROPE S.A.** [CH/CH]; Moulin Du Choc, CH-1122 Romanel-sur-morges (CH).
- (72) Inventor; and
- (75) Inventor/Applicant (for US only): **AMAE, Dominic** [US/US]; 1499 Se Tech Center Drive, Suite 350, Vancouver, Washington 98683 (US).
- (74) Agent: **DAWSON, John, R.**; IPSOLON LLP, 111 S.W. Columbia, Suite 710, Portland, OR 97201 (US).

(81) Designated States (unless otherwise indicated, for every kind of national protection available): AE, AG, AL, AM, AT, AU, AZ, BA, BB, BG, BR, BW, BY, BZ, CA, CH, CN, CO, CR, CU, CZ, DE, DK, DM, DZ, EC, EE, EG, ES, FI, GB, GD, GE, GH, GM, HR, HU, ID, IL, IN, IS, JP, KE, KG, KM, KN, KP, KR, KZ, LC, LK, LR, LS, LT, LU, LV, LY, MA, MD, MG, MK, MN, MW, MX, MZ, NA, NG, NI, NO, NZ, OM, PG, PH, PL, PT, RO, RU, SC, SD, SE, SG, SK, SL, SM, SY, TJ, TM, TN, TR, TT, TZ, UA, UG, US, UZ, VC, VN, YU, ZA, ZM, ZW.

(84) Designated States (unless otherwise indicated, for every kind of regional protection available): ARIPO (BW, GH, GM, KE, LS, MW, MZ, NA, SD, SL, SZ, TZ, UG, ZM, ZW), Eurasian (AM, AZ, BY, KG, KZ, MD, RU, TJ, TM), European (AT, BE, BG, CH, CY, CZ, DE, DK, EE, ES, FI, FR, GB, GR, HU, IE, IS, IT, LT, LU, LV, MC, NL, PL, PT, RO, SE, SI, SK, TR), OAPI (BF, BJ, CF, CG, CI, CM, GA, GN, GQ, GW, ML, MR, NE, SN, TD, TG).

Published:  
— without international search report and to be republished upon receipt of that report

[Continued on next page]

(54) Title: REVERSIBLE BEHIND-THE-HEAD MOUNTED PERSONAL AUDIO SET WITH PIVOTING EARPHONE

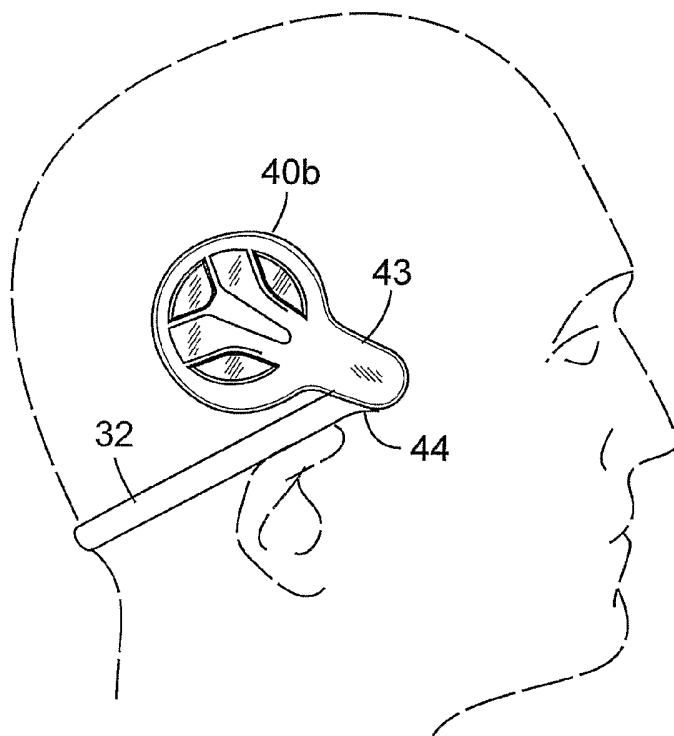

(57) Abstract: A behind-the-head mounted personal audio set that allows a mono-aural personal audio device to be worn in either a wearer's left or right ear without the need to remove or detach individual components of the personal audio set and mount is disclosed. In a disclosed embodiment, the personal audio device has two earphone portions and the mount allows the audio device to operate in either mono or stereo modes wherein one of the earphones may be moved away from a wearer's ear when needed, such as when driving. A boom microphone is preferably pivotally secured to one of the earphone portions.

WO 2006/089250 A2



---

*For two-letter codes and other abbreviations, refer to the "Guidance Notes on Codes and Abbreviations" appearing at the beginning of each regular issue of the PCT Gazette.*

5

Reversible Behind-The-Head Mounted Personal  
Audio Set With Pivoting Earphone

10

Cross-Reference to Related Application

This application claims priority to U.S. provisional patent application serial number 60/653,712, filed on February 16, 2005.

15

Field of the Invention

The present invention relates to a personal audio set with individually pivoting ear-phones to allow the audio set to be reversible and/or to operate either as a mono or stereo system.

20

Background of the Invention

Personal audio-sets, commonly known as headphones, earphones, headsets, and the like, are gaining in popularity. The typical personal audio-set includes a frame containing an earphone that is usually positioned over or  
25 in a wearer's ear. In cases where the audio-set is a headset, a microphone is also typically positioned near the wearer's mouth.

One method for detachably securing a personal audio-set to a wearer includes securing the personal audio-set to a headband that encircles the rear portion of the wearer's head. These types of mounting structures are  
30 commonly known as "behind-the-head" mounts.

Known behind-the-head mounts have several drawbacks. For example, in cases where they are used with a mono-aural personal audio set

or the like, they do not allow a wearer to easily reverse the orientation of the personal audio set such that it may be worn adjacent to either the wearer's left or right ears. This type of reversibility is a desirable characteristic in a personal audio set.

5           Known behind-the-head mounts for personal audio sets usually require the wearer to detach one or more pieces from the mounting structure and then reattach in a different orientation or location along the mount. In practice, such reversible behind-the-head mounts are difficult to use correctly and tend to wear prematurely due to repeated detaching and reattaching of  
10 the mount components. Moreover, individual pieces of the detachable structure are prone to being misplaced or lost, thereby limiting the use of the structure or in some cases rendering the structure useless.

          Also, in cases where the personal audio set operates in stereo, ear  
15 phones usually cover both of the wearer's ears. Such covering of both ears is undesirable in some circumstances, such as when the wearer is driving. Moreover, covering both ears with a personal audio set may even violate local or state laws when driving.

#### Summary of the Invention

20           Accordingly, despite the available behind-the-head mounts for personal audio sets, there remains a need for a light weight, stylish, durable, and economical, mount that allows a mono-aural personal audio device to be worn in either a wearer's left or right ear without the need to remove or detach individual components of the personal audio sent and mount. There also  
25 remains a need that allows a personal audio device having two earphones to operate in either mono or stereo modes wherein one of the phones may be moved away from a wearer's ear when needed, such as when driving. In addition to other benefits that will become apparent in the following disclosure, the present invention fulfills these needs.

30

### Brief Description of the Drawings

Fig. 1 is a front, left, perspective view of a behind-the-head mounted personal audio set having individually pivoting headphones operably secured thereto and a boom microphone pivotally secured to one of the headphone assemblies showing a possible concealed position of the boom microphone in accordance with an embodiment of the present invention.

Fig. 2 is a right, perspective view of the of the behind-the-head mounted personal audio set of Fig. 1 showing a possible orientation of the boom microphone on the right side of the headset and a possible operational position of the boom microphone.

Fig. 3 is a rear, right, perspective view of the behind-the-head mounted personal audio set of Fig. 1 showing a possible orientation of the boom microphone on the right side of the headset with the boom microphone in the operational position.

Fig. 4 is a front, right perspective view of the behind-the-head mounted personal audio set of Fig. 1 in the configuration of Fig. 2 showing a possible mounting on a wearer shown in hidden lines.

Fig. 5 is a front, right, perspective view of the behind-the-head mounted personal audio set of Fig. 4 showing a possible position of one of the headphones so as to allow the personal audio set to operate in mono without covering one of the wearer's ears.

Fig. 6 is a right, perspective, partially exploded view of the behind-the-head mounted personal audio set of Fig. 2.

Fig. 7 is a front, left, perspective view of the behind-the-head mounted personal audio set of Fig. 1, showing a possible orientation with the boom microphone positioned on the wearer's right side.

Fig. 8 is a right side view of the behind-the-head mounted personal audio set of Fig. 1, in a second possible stereo configuration with the boom microphone positioned on the wearer's left side.

Fig. 9 is a right side view of the behind-the-head mounted personal audio set of Fig. 1, in a first possible mono configuration showing the

earphone adjacent to the wearer's right ear pivoted so as to not cover the wearer's right ear.

Fig. 10 is a right side view of the behind-the-head mounted personal audio set of Fig. 1 with the earphone adjacent to the wearer's right ear  
5 pivoted so as to not cover the wearer's right ear, and with the boom microphone pivoted into an operational position adjacent to the wearer's mouth.

Fig. 11 is a right side view of the behind-the-head mounted personal audio set of Fig. 1 showing a possible orientation on a wearer's left ear.

10 Fig. 12 is a top, right, perspective view of the behind-the-head mounted personal audio set of Fig. 1, showing a possible pivoted position of the boom microphone.

Fig. 13 is a front, right, perspective view of the behind-the-head mounted personal audio set of Fig. 12.

15 Fig. 14 is an enlarged view of the boom microphone of Fig. 3 showing the possible operational position of the boom microphone.

Fig. 15 is an left, perspective view of the behind-the-head personal audio set of Fig. 1 showing the possible concealed position of the boom microphone of the left side.

20 Fig. 16 is a back, right, perspective view of the behind-the-head mounted personal audio set of Fig. 15 with the boom microphone positioned as shown in Fig. 14.

Fig. 17 is a top view of the behind-the-head mounted personal audio set of Fig. 1 with the boom microphone positioned on the left side and as  
25 shown in Fig 14.

Fig. 18 is an enlarged top view of the left earphone of the behind-the-head mounted personal audio set of Fig. 1.

Fig. 19 is an enlarged rear view of the left earphone of Fig. 18.

Fig. 20 is a right, side view of the left earphone of Fig. 18.

30

### Detailed Description of Preferred Embodiments

A behind-the-head mounted personal audio set 30 having two earphone portions 40a, 40b, each independently pivotally secured to a behind-the-head headband 32, is shown in Figs. 1-20.

5 In a preferred embodiment, the behind-the head mounted personal audio set 30 has a curved headband 32, preferably occupying a common plane 34 as best shown in Fig. 1. As best shown in Figs. 4, 5, and 7-11, the headband 32 is preferably sized to encircle and slightly grasp the rear contour of a wearer's head 36 substantially between the wearer's ears 38a, 38b.

10 As shown in Figs. 1-6, the earphone portions 40a, 40b are preferably positioned on opposite ends of the headband 32 at individual pivots 47a, 47b. Each pivot 47a, 47b operably secures an earphone-mounting portion 42 which as a substantially elongate pivot mounting portion 43 extending therefrom to operably engage the pivot, each earphone-mounting portion  
15 contains an earphone 39 therein. Preferably, the center 41 of each earphone 39 is positioned below the common plane 34 of the headband during stereo use of the personal audio set.

More preferably, the personal audio set 30 is a headset 30' having a mini- boom microphone 46 extending therefrom. The mini-boom microphone  
20 46 is preferably pivotally secured to the headset-mounting portion 42 at a defined third pivot 48. The length of the boom portion of the mini-boom microphone is preferably sized to define a concealed position 100 as best shown in Figs. 1 & 15 when aligned with the substantially elongate pivot mounting portion 43. The mini-boom microphone may be pivoted about the  
25 third pivot 48 to define an operational position 102 of the mini-boom microphone as best shown in Figs. 2-5, 7, 8, 12-14 and 16-20.

By pivoting the earphone mounting portions 42 about their respective pivots and the mini-boom microphone about the third pivot 48, the headset may be worn so that each earphone is positioned over one of the wearer's  
30 ears with the mini-boom microphone 46 positioned on either the wearer's left side as shown in Figs. 4, 5 and 8, or a wearer's right side as shown in Fig. 7.

In addition, should the user desire or require using the personal audio-set in mono mode, and not have one of the earphone portions 40b cover an ear, as shown in Fig. 5, the user can pivot one of the earphone mounting portions 42 about its respective pivot 47b so that that earphone portion rests  
5 away from the respective ear. For example, one possible mono configuration is shown in Figs. 8 and 9 shows one earphone portion 40a positioned over the wearer's right ear with the earphone mounting portion 42 containing the boom microphone 46 pivoted to its engaged position (Fig. 8) while the other earphone portion 40b is pivoted away from the wearer's left ear (Fig 9). It can  
10 be appreciated that the disclosed structure can also be pivoted about its three pivots to provide the same basic configurations while covering the right ear with an earphone and preventing the left ear from being covered with an earphone.

An alternative possible mono configuration is shown in Figs. 10 and 11  
15 with one earphone portion 40a moved forward of the wearer's left ear with the boom microphone 46 extending there from towards the wearer's mouth as shown in Fig. 10 and the opposite earphone portion 40b covering the wearer's right ear as shown in Fig. 11. It can be appreciated that the disclosed structure can also be pivoted about its three pivots to provide the  
20 same basic configurations while covering the left ear with an earphone and preventing the right ear from being covered with an earphone.

Preferably, the earphone portion 40a positioned nearest to the mini-boom microphone 46 is displaced from the wearer's ear during mono use as best shown in Fig. 10. However, the disclosed structure also allows a user to  
25 position the earphone furthest away from the mini-boom microphone away from the user's ear during mono use as shown in Fig. 5.

Preferably, the first and second pivots 47a, 47b are aligned along a defined three dimensional angle with respect to the headband 32 so as to optimize wearer comfort. This defined angle is shown as three two-  
30 dimensional angles in Figs. 18-20 and labeled "angle 1" (Fig. 18), "angle 2" (Fig. 19), and "angle 3" (Fig. 20). Preferably, "angle 1", which biases the



position of the earphone portion of the audio set to fit the angle of a human ear when viewed from the top of the head is 12 degrees plus or minus 10 degrees. "Angle 2" (Fig. 19), which is the angle between the intersection of the first pivot 47a and the second pivot 48, is preferably 25 degrees plus or minus 20 degrees and "angle 3", which is the angle between the common  
5 plane 34 of the headband 32 and the longitudinal centerline 45 of the headset mounting portion 42, is preferably about 60 degrees plus or minus 30 degrees. More preferably, "angle 3" is about 63 degrees.

More preferably, the first and second pivots 47a, 47b includes a detent  
10 mechanism 60 to allow proper alignment when the audio set 30 is positioned for wearing adjacent to either a wearer's left or right ears. Preferably, four detents are provided, one for the left ear position shown in Fig. 4, one for the right ear position shown in Fig. 7, one for the first desired mono position shown in Fig 10, and one for the second desired mono position shown in Fig.  
15 9.

One possible pivot structure for the first and second pivot 47a, 47b is shown in Fig. 6. The opposite ends 44 of the headband 32 each include a recess 62 defining a cam surface 64. Recesses 66 are placed at defined positions along the cam surface 64 to define the detent positions. The  
20 headset mounting portion 42 includes a circular recess 68 sized to rotate about a circular protrusion 70 extending from the first end 44 of the headband 32. Preferably, a resilient o-ring 47 is positioned between the circular recess 68 and the circular protrusion 70 to create frictional holding force. A detent spring 72 is positioned within the recess 62 and secured to the headset  
25 mounting portion 42 with a fastener 74. Preferably the detent spring 72 is sized to engage the recesses 66 in the cam surface 64 thereby urging the headset mounting portion 42 to one of the defined detents. More preferably, a cover 76 covers the fastener 74 and detent spring 72.

A possible pivot structure for the third pivot 48 is shown in Fig. 6. The  
30 headset mounting portion 42 includes a substantially circular opening 80 about which the mini-boom microphone is pivotally secured thereto. The

headset-mounting portion 42 preferably includes operating electronics therein. Preferably, an o-ring 86 is positioned within the circular opening 80 to hold a desired position of the mini-boom microphone. The personal audio set may be wired or wireless.

5           If desired, the electronics can contain suitable electronic control systems and control logic to deactivate the earphone not positioned adjacent to a wearer's ear during mono-use. This deactivation can be manually activated through a control button or the like positioned on the personal audio-set, or automatically detected by the control system based on  
10 predetermined criteria such as the position of the earphone mounting portions relative to the predetermined detents on the pivots. Alternatively, the control system can deactivate one earphone during use of the mini-boom microphone such as when a user is initially listening to music from one source, and then receives a phone call from another source.

15           Preferably, controls 125 in communication with the electronics, such as volume control, channel selection, on/off and the like are provided on an exterior surface of one of the earphone mounting portions. More preferably, these controls are positioned so as to allow them to be substantially at the same locations relative to the earphone mounting portion when that earphone  
20 mounting portion is worn on either the wearer's left or right ears. For example, the primary control is preferably a button positioned on the centerline of the earphone.

          Having described and illustrated the principles of our invention with reference to a preferred embodiment thereof, it will be apparent that the  
25 invention can be modified in arrangement and detail without departing from such principles. In view of the many possible embodiments to which the principles may be put, it should be recognized that the detailed embodiment is illustrative only and should not be taken as limiting the scope of our invention.

          Accordingly, we claim as our invention all such modifications as may come  
30 within the scope and spirit of the following claims and equivalents thereto.

## CLAIMS

I Claim:

1. A behind-the-head mounted personal audio set comprising:  
a substantially elongate headband portion defining a longitudinal  
5 centerline, said headband portion curved to encircle the crown of the wearer's  
head;  
a first earphone portion pivotally secured to the headband portion at a  
defined first pivot, said first earphone portion containing a boom microphone  
operably secured thereto; and,  
10 said first pivot operable to allow said first earphone portion to be  
operably positioned adjacent to one of either the wearer's left and right ears.
  
2. The behind-the-head mounted personal audio set of claim 1,  
further including:  
15 a second earphone portion pivotally secured to the headband portion  
at a defined second pivot.  
said second pivot operable to allow said second earphone portion to  
be operably positioned adjacent to other of the wearer's left and right ears.
  
- 20 3. The behind-the-head mounted personal audio set of claim 1,  
wherein said microphone is pivotally secured to said first earphone portion at  
a defined third pivot.
  
4. The behind-the-head mounted personal audio set of claim 3,  
25 wherein said first pivot and said third pivot are spaced apart from each other  
by a defined distance.
  
5. The behind-the-head mounted personal audio set of claim 2,  
wherein said first earphone portion may be pivoted about said first pivot away  
30 from said one of said left and right ears while said second earphone portion  
operably covers said other of said left and right ears.

6. The behind-the-head mounted personal audio set of claim 1, wherein said boom microphone has an engaged position wherein it operably extends toward the wearer's mouth, and a retracted position.

5

7. The behind-the-head mounted personal audio set of claim 1, wherein said first earphone portion extends below said first pivot.

8. The behind-the-head mounted personal audio set of claim 3, wherein a first angle, defined as an angle between the intersection of said first pivot and said third pivot, is 25 degrees plus or minus 20 degrees.

9. The behind-the-head mounted personal audio set of claim 8, wherein said first angle is substantially near 25 degrees.

15

10. The behind-the-head mounted personal audio set of claim 3, wherein said headband defines a common plane, and a second angle, defined as an angle between said common plane and a longitudinal centerline of the first earphone portion is 60 degrees plus or minus 30 degrees.

20

11. The behind-the-head mounted personal audio set of claim 10, wherein said second angle is substantially near 63 degrees.

12. The behind-the-head mounted personal audio set of claim 2, further including a first set of detents for operably positioning said first earphone portion about said first pivot to align said earphone with one of said left and right ears.

30

13. The behind-the-head mounted personal audio set of claim 12, further including a second set of detents for operably positioning said first earphone portion about said first pivot away from one of said left and right ears.

5

14. The behind-the-head mounted personal audio set of claim 12, further including a third set of detents for operably positioning said second earphone portion about said second pivot to align said second earphone with the other of said left and right ears.

10

15. The behind-the-head mounted personal audio set of claim 14, further including a fourth set of detents for operably position said second earphone portion about said second pivot away from the other of said left and right ears.

15

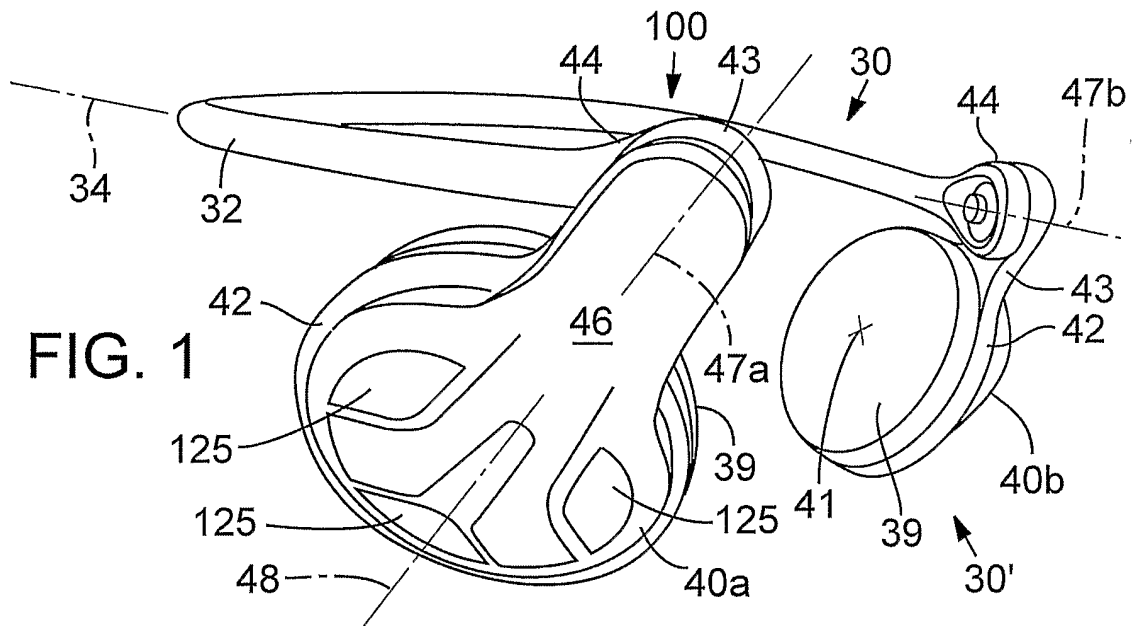

FIG. 1

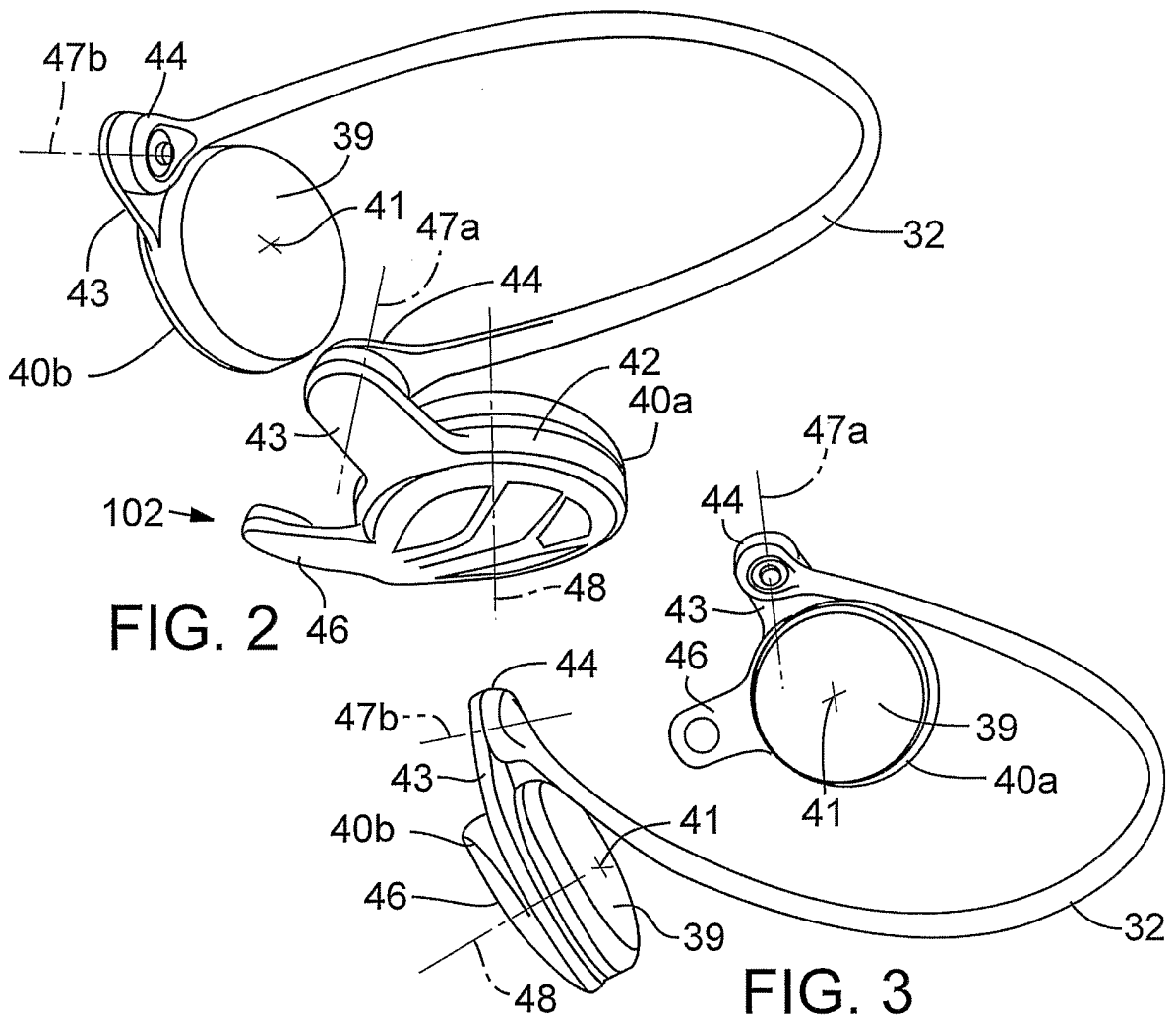

FIG. 2

FIG. 3

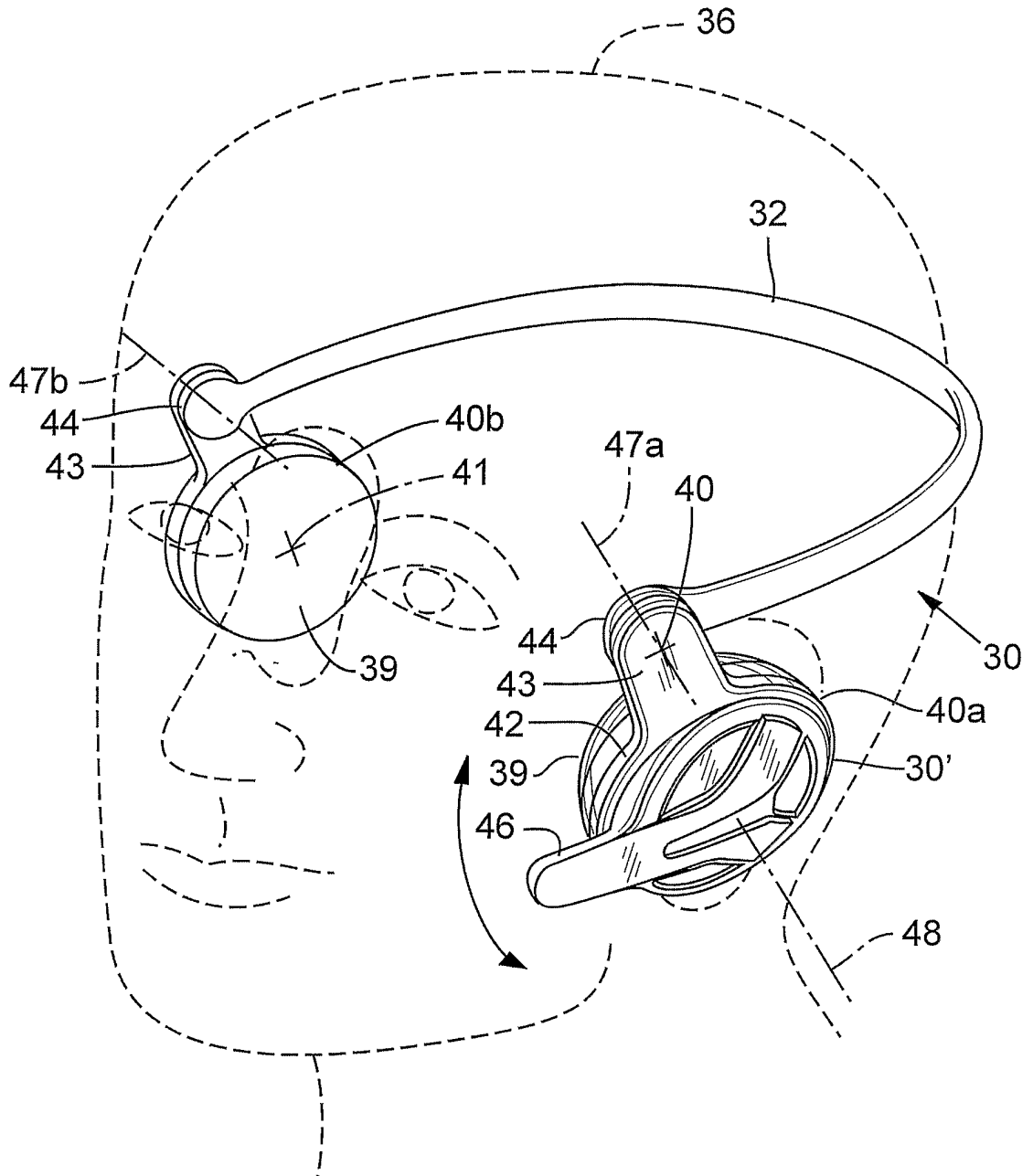

FIG. 4

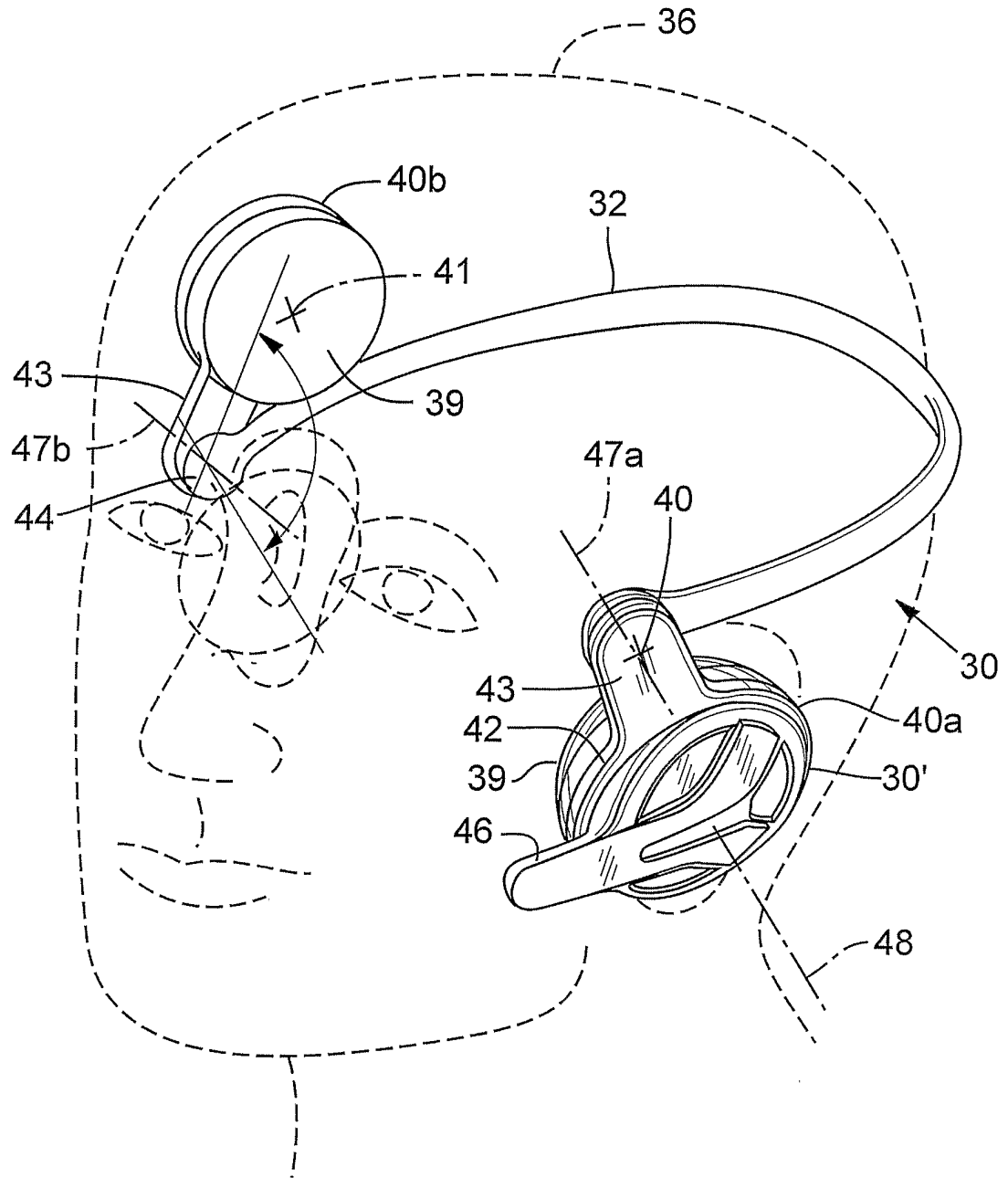

FIG. 5



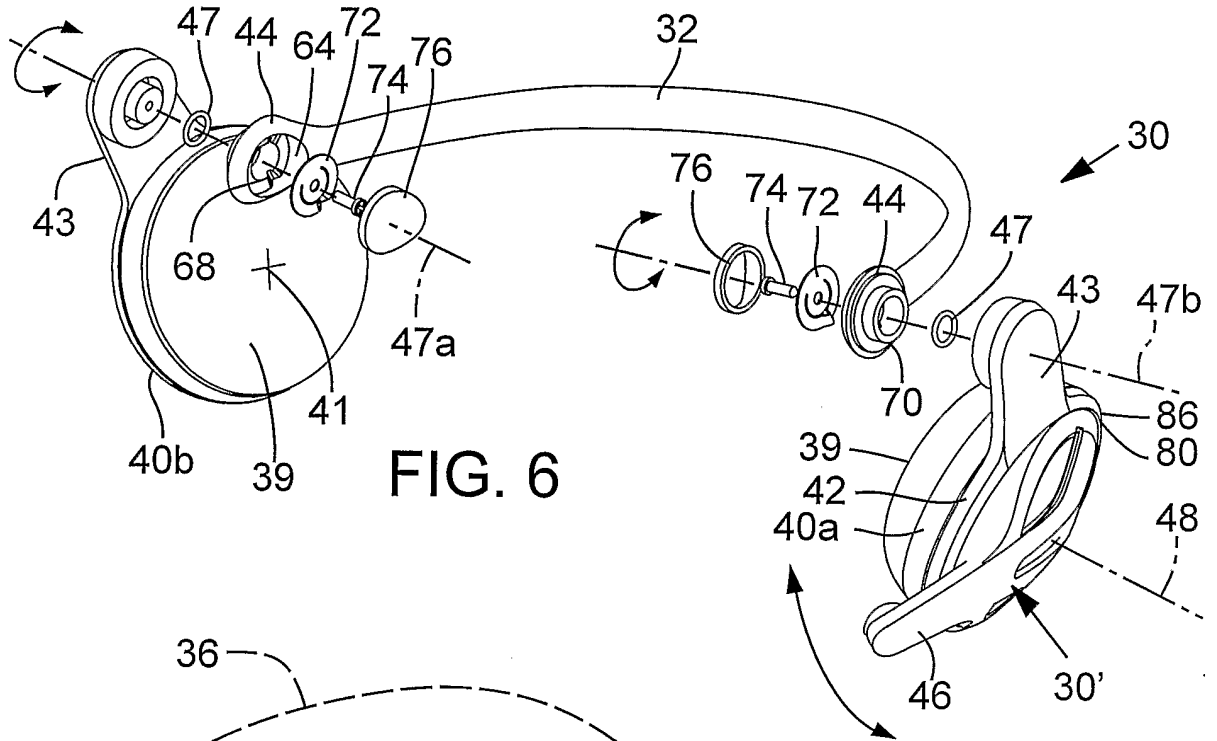

FIG. 6

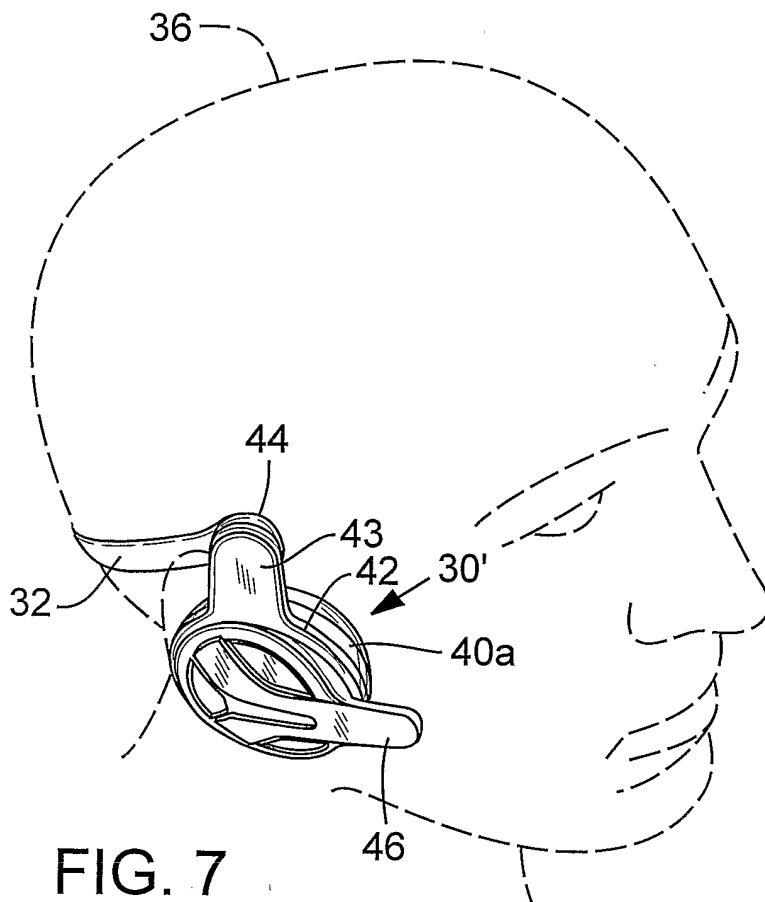

FIG. 7

5/10

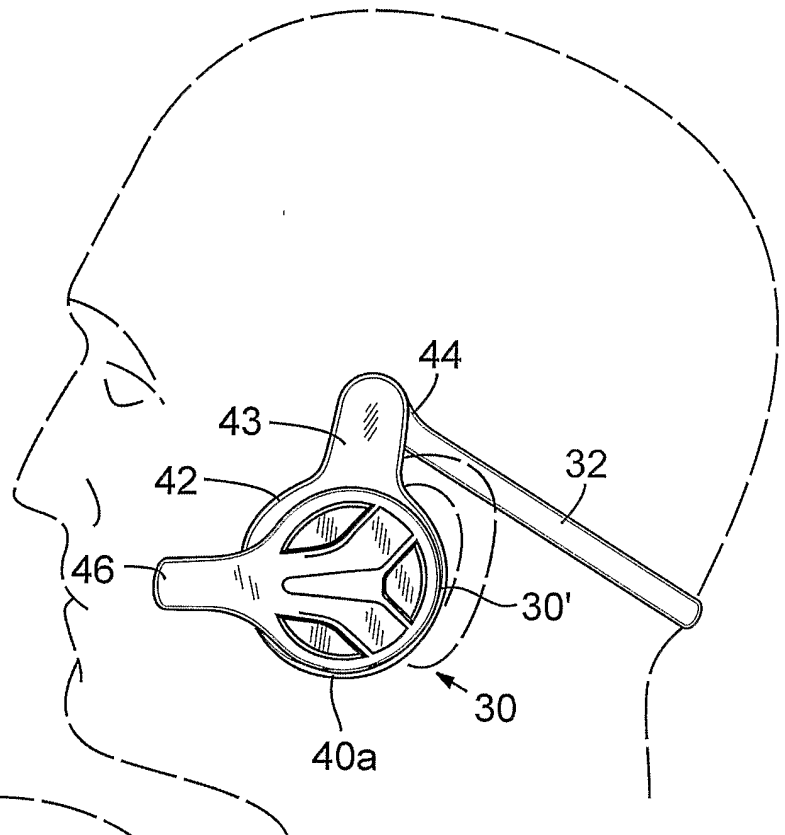

FIG. 8

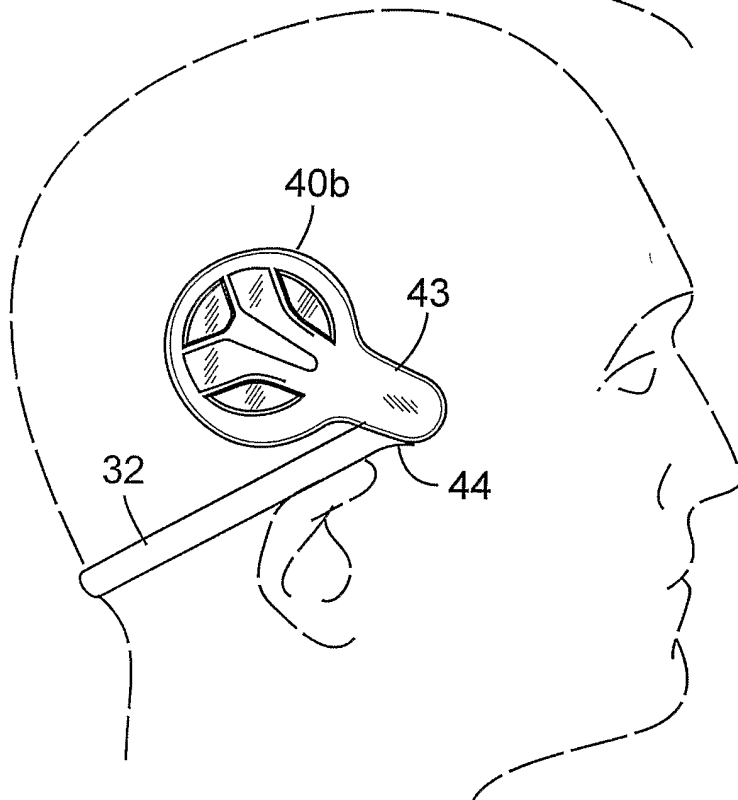
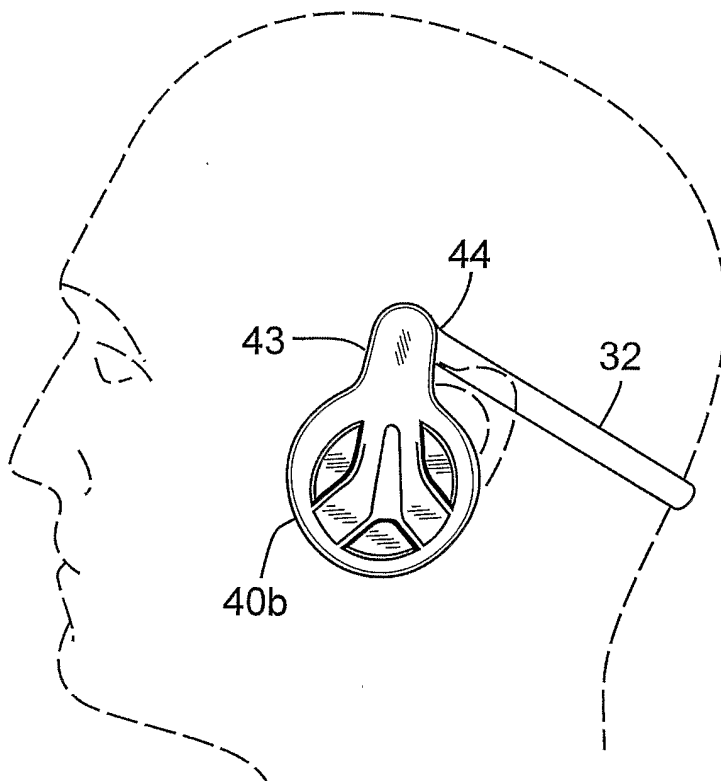
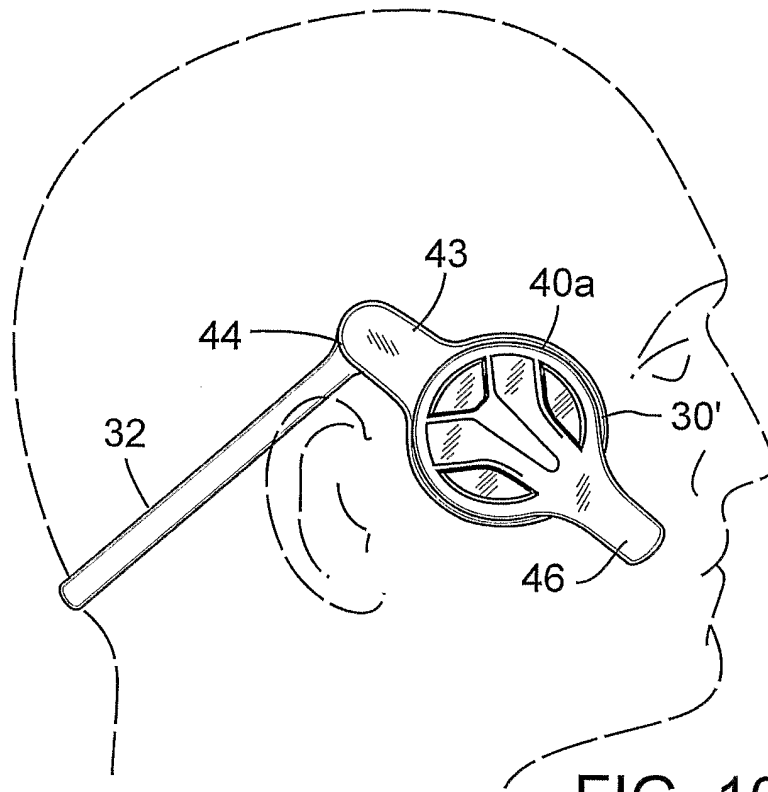
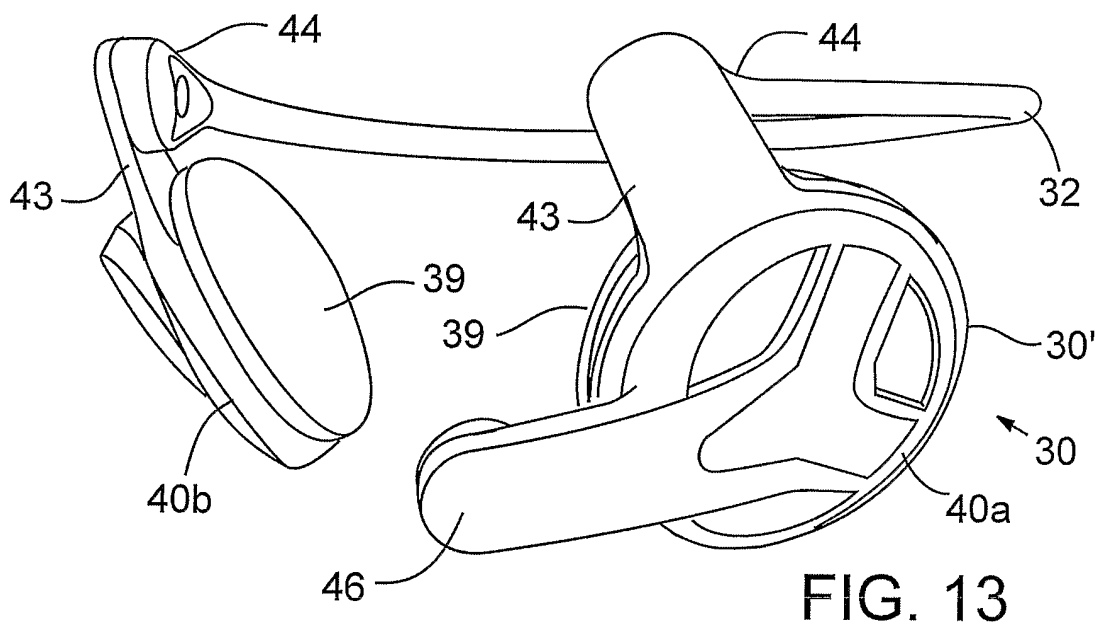
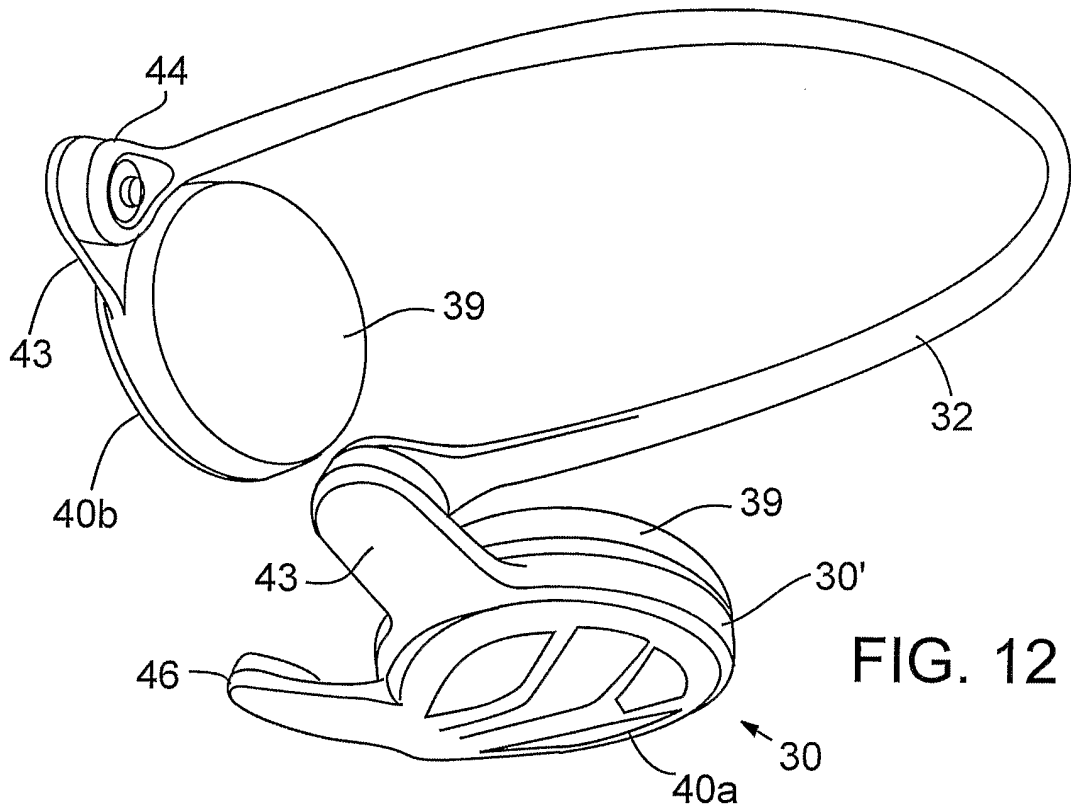

FIG. 9

6/10



7/10



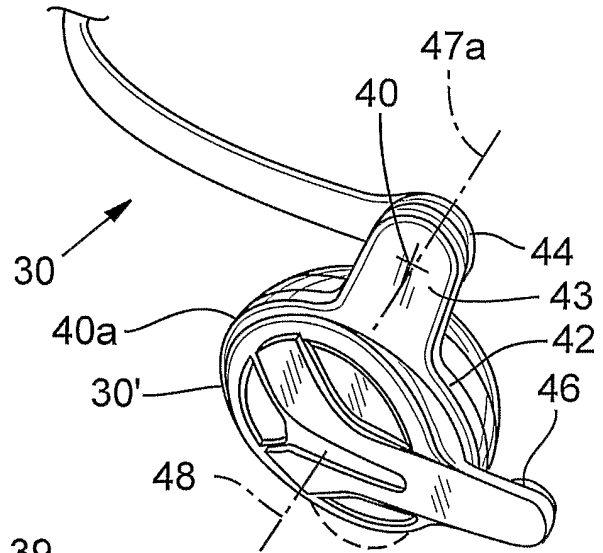

FIG. 14

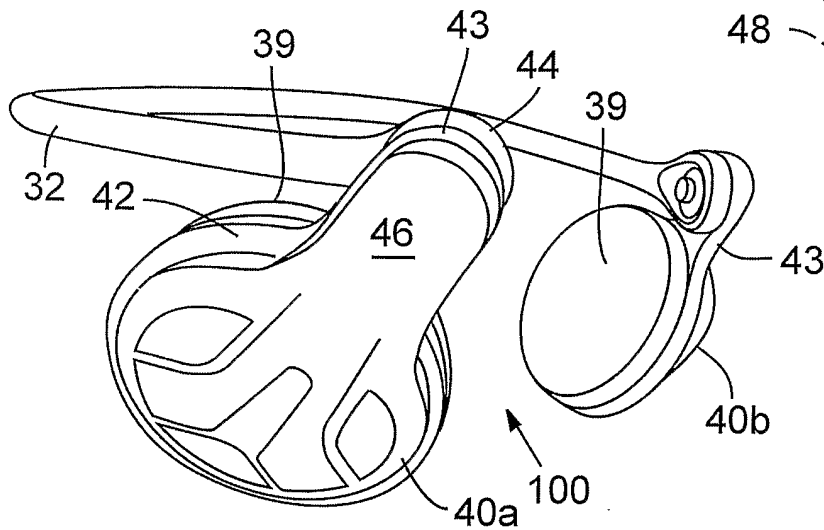

FIG. 15

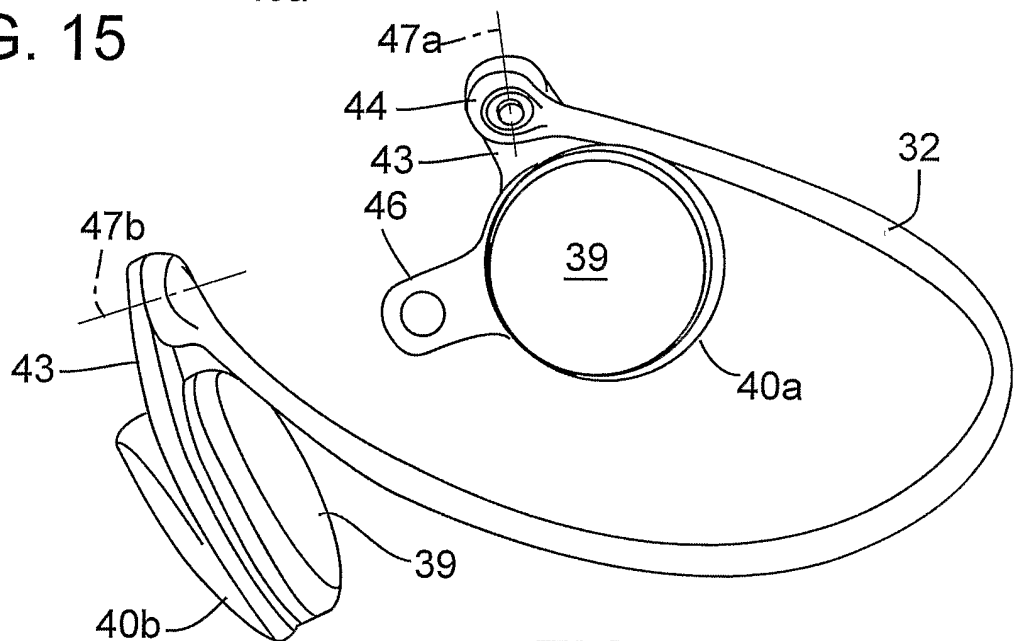

FIG. 16

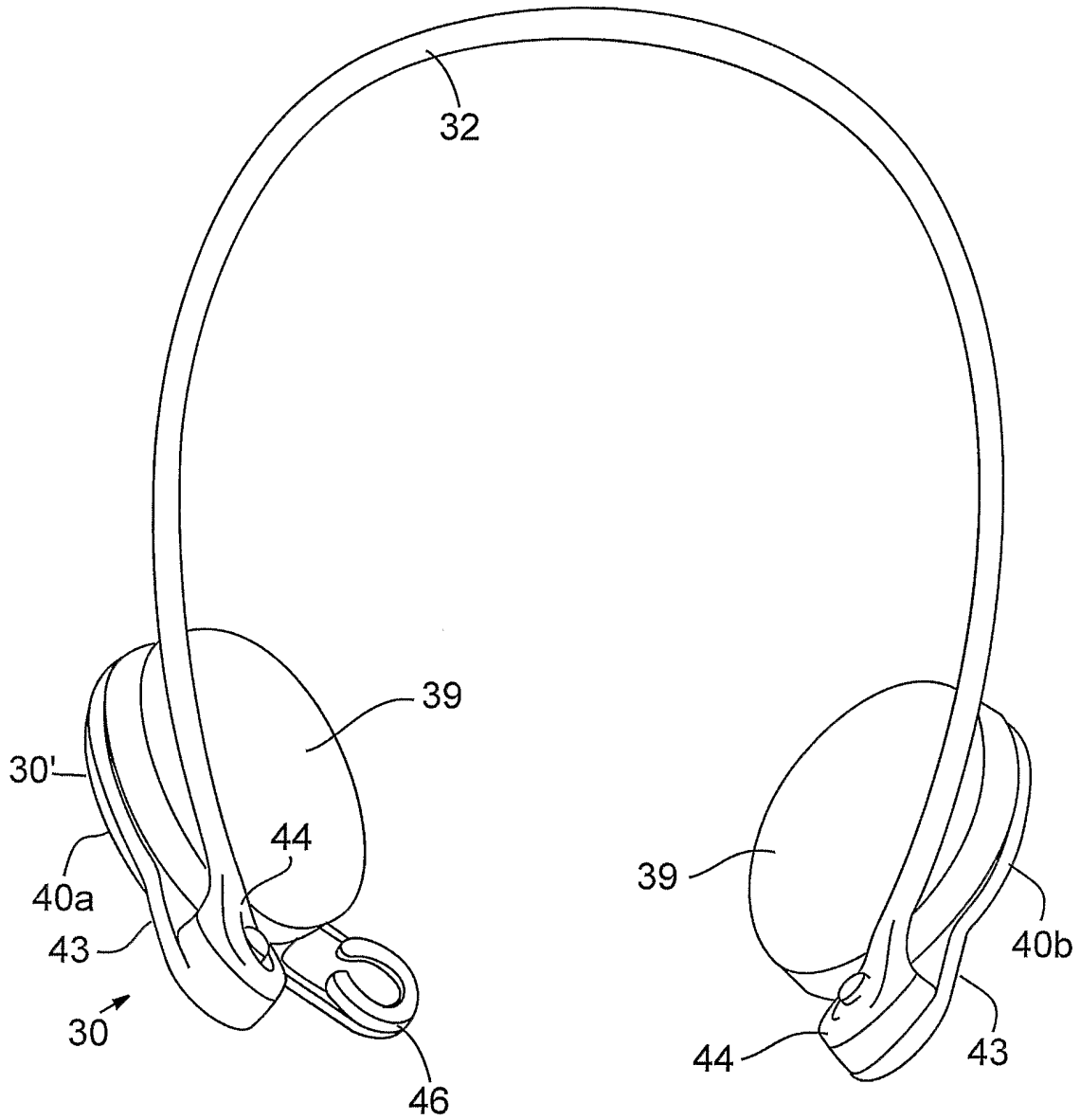

FIG. 17

