



US 20070060799A1

(19) **United States**

(12) **Patent Application Publication**
Lyon et al.

(10) **Pub. No.: US 2007/0060799 A1**

(43) **Pub. Date: Mar. 15, 2007**

(54) **APPARATUS AND METHOD FOR
AUTOMATIC IMAGE GUIDED ACCURACY
VERIFICATION**

Related U.S. Application Data

(63) Continuation-in-part of application No. 11/224,028,
filed on Sep. 13, 2005.

(76) Inventors: **Torsten M. Lyon**, Golden, CO (US);
Troy L. Holsing, Nashville, TN (US);
Jerome R. Edwards, Nashville, TN
(US); **Christopher B. Lee**, Nashville,
TN (US); **Evan Austill JR.**, Nashville,
TN (US)

Publication Classification

(51) **Int. Cl.**
G06T 7/20 (2006.01)
(52) **U.S. Cl.** **600/300; 382/128**

(57) **ABSTRACT**
A method includes receiving during a first time interval associated with a path of motion of a dynamic body, image data associated with a plurality of images of the dynamic body. The plurality of images include an indication of a position of a first marker coupled to a garment at a first location, and a position of a second marker coupled to the garment at a second location. The garment is coupled to the dynamic body. During a second time interval, an image from the plurality of images is automatically identified that includes a position of the first marker that is substantially the same as a position of a first localization element relative to the dynamic body and a position of the second marker that is substantially the same as a position of the second localization element relative to the dynamic body.

Correspondence Address:
COOLEY GODWARD KRONISH LLP
ATTN: PATENT GROUP
Suite 500
1200 - 19th Street, NW
WASHINGTON, DC 20036-2402 (US)

(21) Appl. No.: **11/410,143**

(22) Filed: **Apr. 25, 2006**

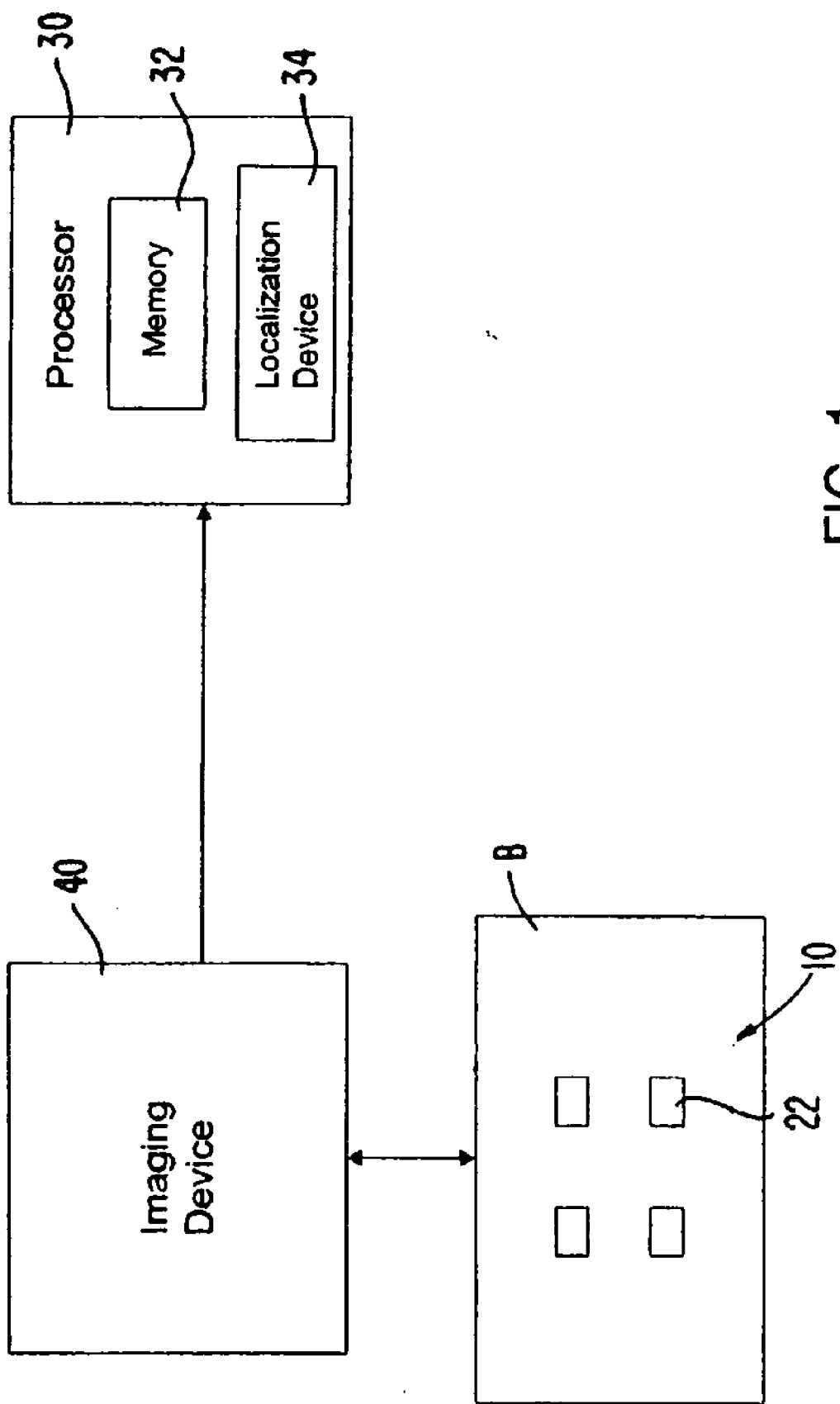
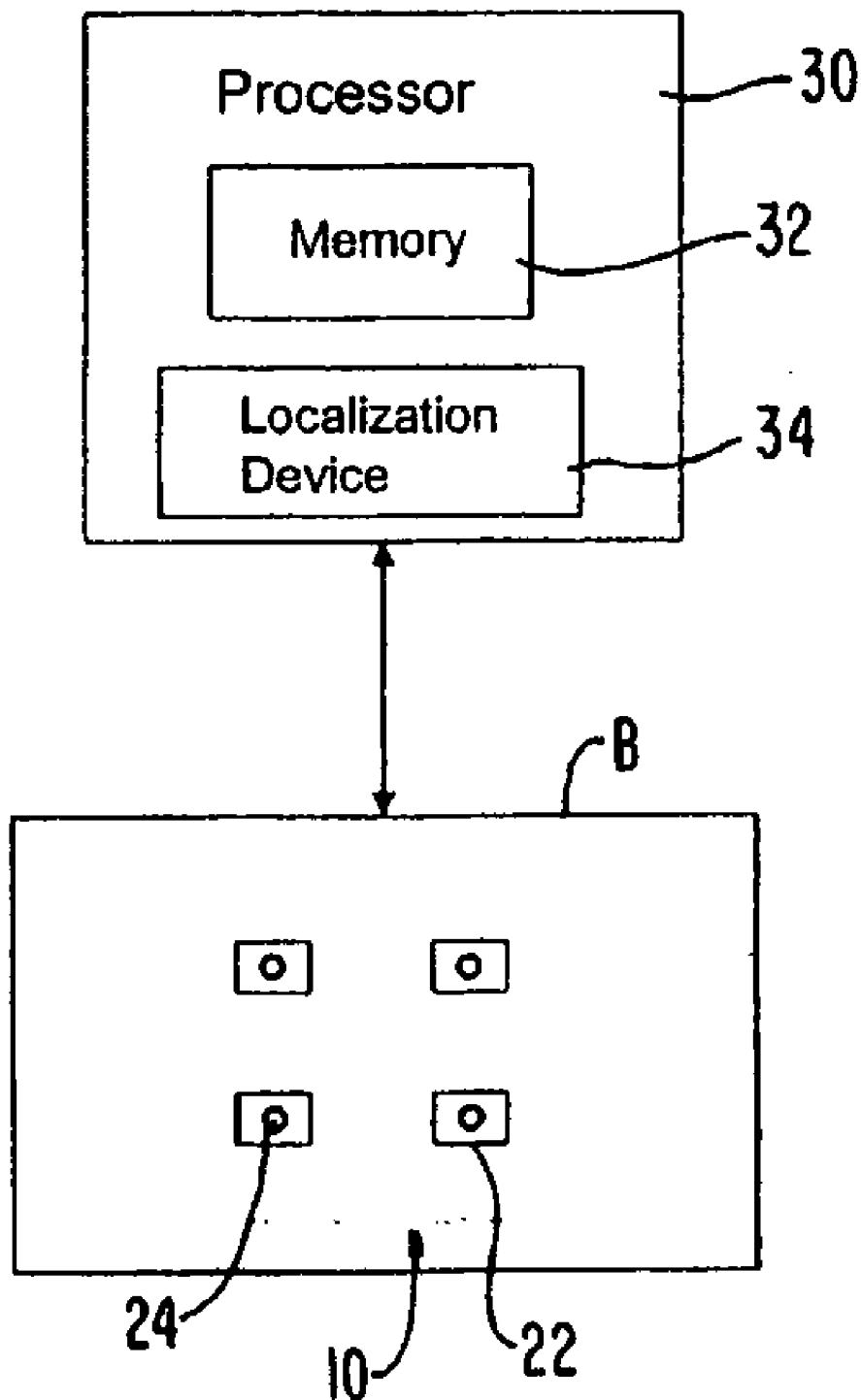

FIG. 1

FIG. 2



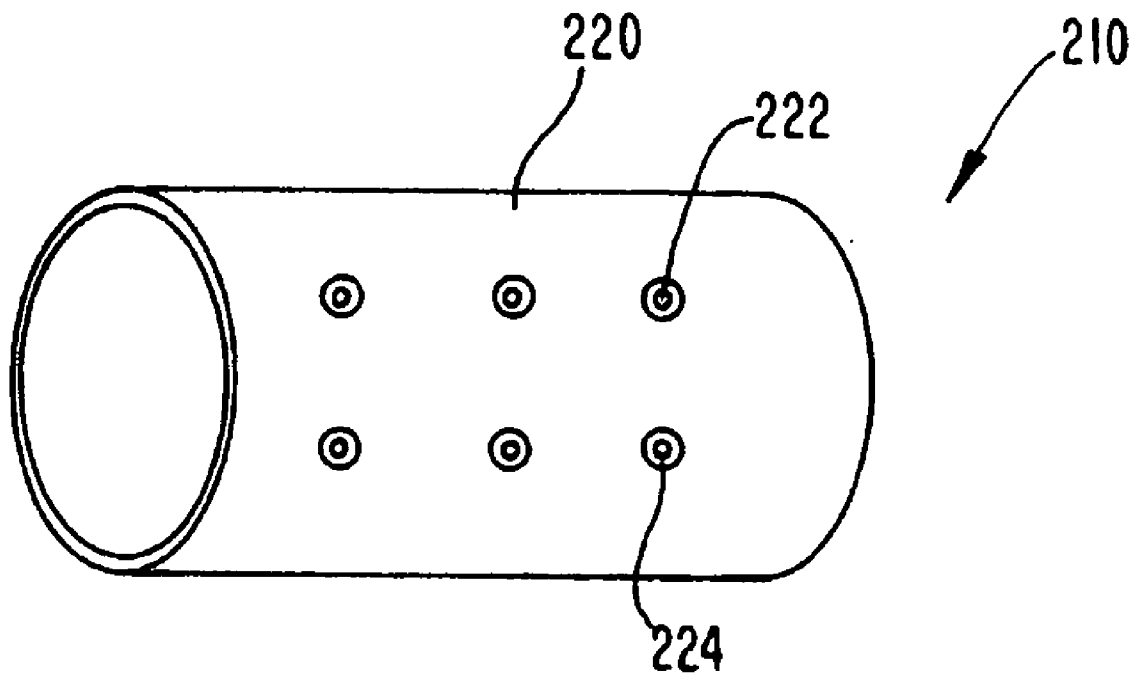

FIG. 3

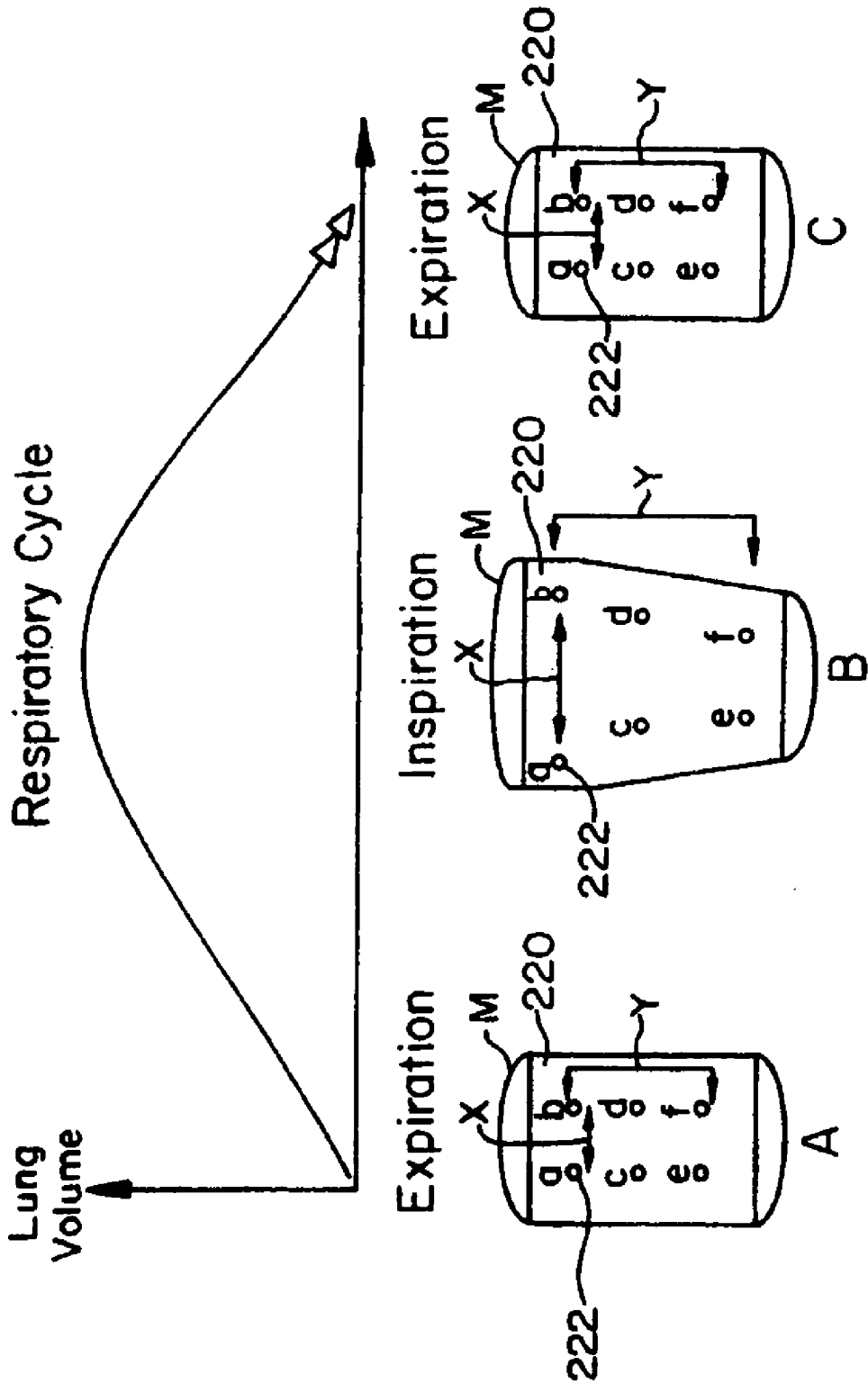

FIG. 4

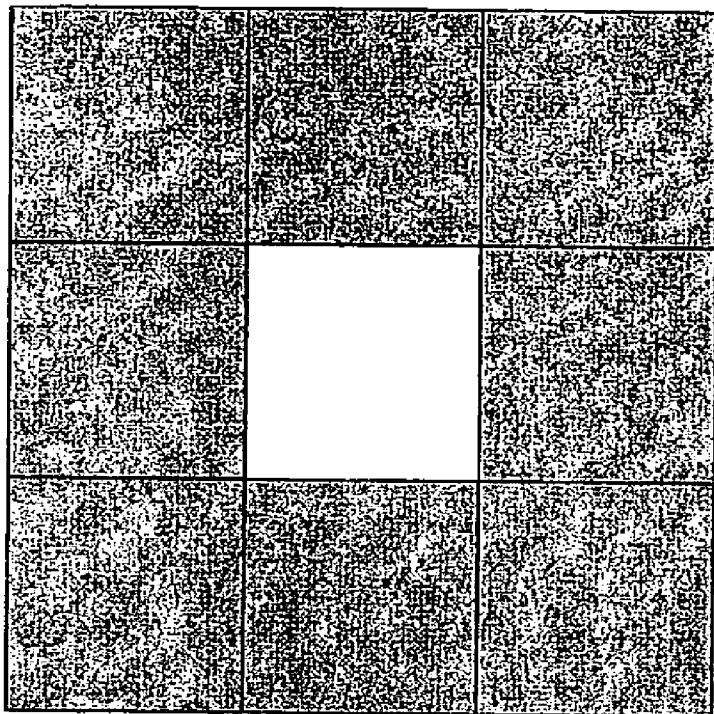

FIG. 5

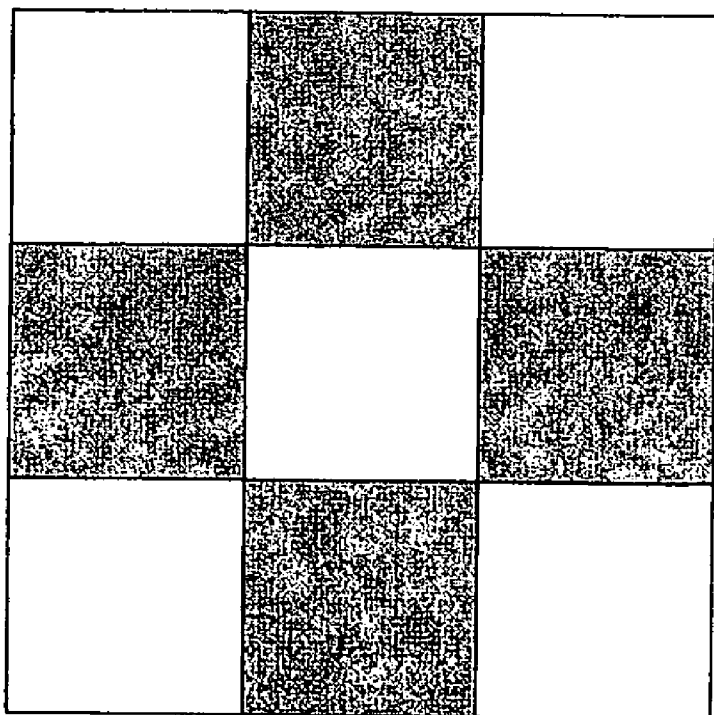

FIG. 6

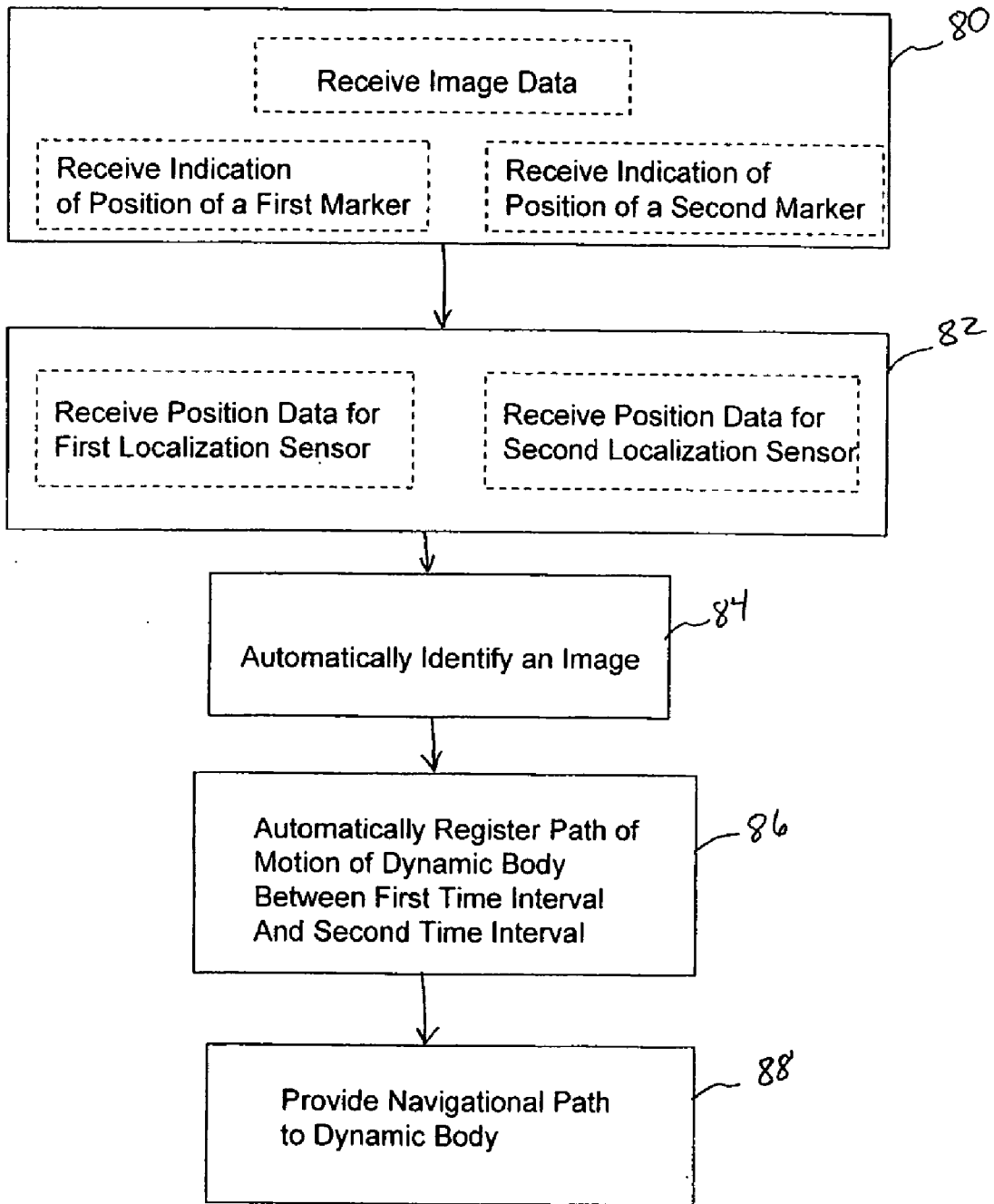

FIG. 7

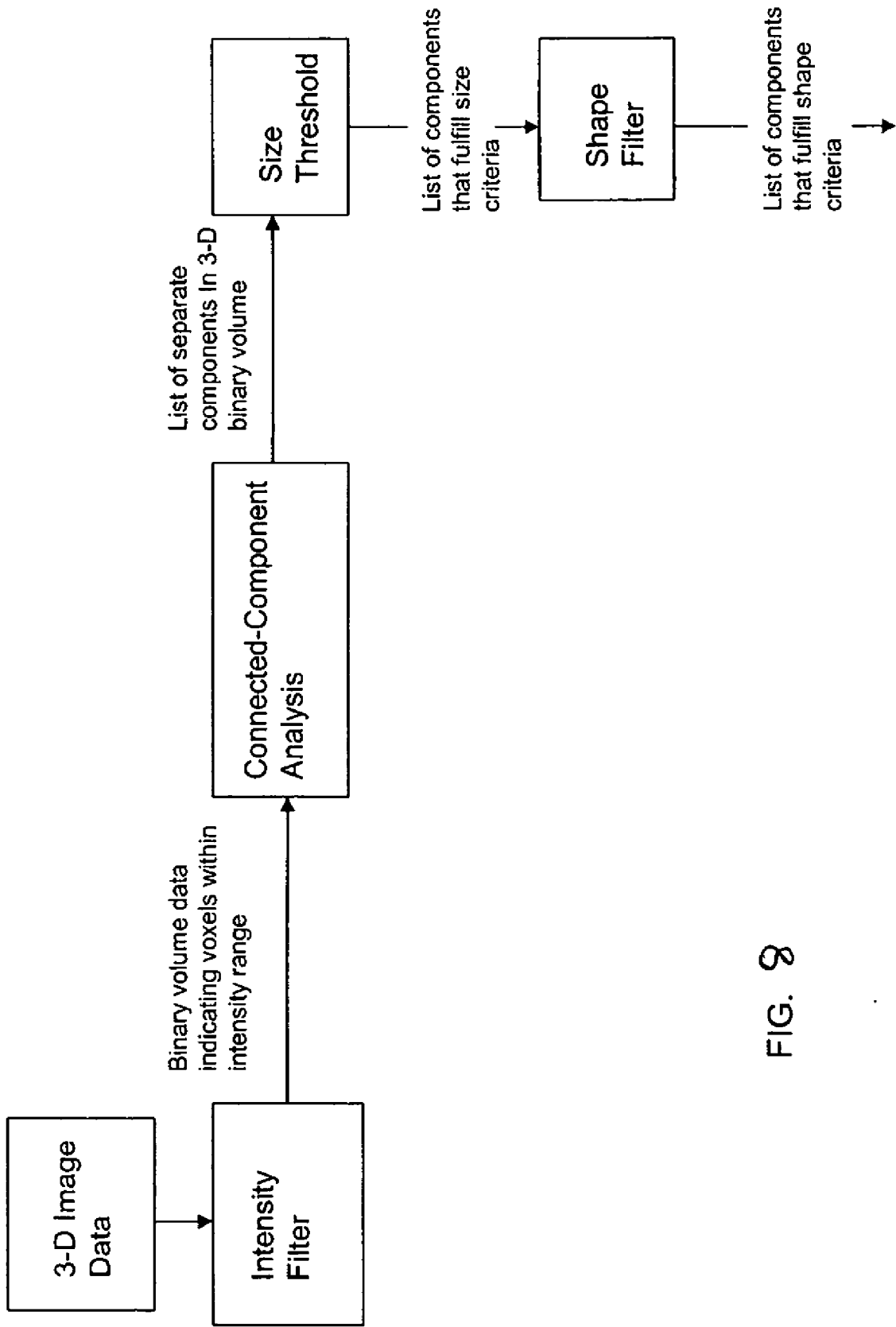

FIG. 8

APPARATUS AND METHOD FOR AUTOMATIC IMAGE GUIDED ACCURACY VERIFICATION

CROSS-REFERENCE TO RELATED APPLICATIONS

[0001] This application is a continuation-in-part of U.S. patent application Ser. No. 11/224,028, filed Sep. 13, 2005, entitled "Apparatus and Method for Image Guided Accuracy Verification," the disclosure of which is hereby incorporated by reference in its entirety.

BACKGROUND

[0002] The invention relates generally to a medical device and particularly to an apparatus and method associated with image guided medical procedures.

[0003] Image guided surgery (IGS), also known as image guided intervention (IGI), enhances a physician's ability to locate instruments within anatomy during a medical procedure. IGS can include 2-dimensional (2-D) and 3-dimensional (3-D) applications.

[0004] Existing imaging modalities can capture the movement of dynamic anatomy. Such modalities include electrocardiogram (ECG)-gated or respiratory-gated magnetic resonance imaging (MRI) devices, ECG-gated or respiratory-gated computer tomography (CT) devices, and cinematography (CINE) fluoroscopy. The dynamic imaging modalities can capture the movement of anatomy over a periodic cycle of that movement by sampling the anatomy at several instants during its characteristic movement and then creating a set of image frames or volumes. Such images can be used to help a physician navigate a medical instrument to the desired location on the anatomical body during a medical procedure performed on the anatomical body at a later time.

[0005] Typical image-guided medical systems require manual user input to identify a pre-procedural image that corresponds to the same position and orientation of an anatomical body during a medical procedure. These manual operations can lead to greater errors and reduced efficiency in image-guided procedures.

[0006] Thus, a need exists for a method and apparatus that can automatically identify pre-procedural images of a targeted anatomical body that can be used to help a physician navigate a medical instrument to a selected location on the anatomical body during a range of motion of the anatomical body.

SUMMARY OF THE INVENTION

[0007] Apparatuses and methods for performing gated instrument navigation on dynamic anatomy with automatic image registration are disclosed herein. In one embodiment, a method includes receiving during a first time interval image data associated with a plurality of images of a dynamic body. The plurality of images includes an indication of a position of a first marker on a garment coupled to the dynamic body and a position of a second marker on the garment coupled to the dynamic body. The first marker is coupled to the garment at a first location, and the second marker is coupled to the garment at a second location. The first time interval is associated with a path of motion of the dynamic body. During a second time interval after the first time interval, data is received that is associated with a

position of a first localization element relative to the dynamic body, and data is received that is associated with a position of a second localization element relative to the dynamic body. The first localization element is coupled to the garment at the first location, and the second localization element is coupled to the garment at the second location. The second time interval is associated with a path of motion of the dynamic body. During the second time interval, an image from the plurality of images is automatically identified that includes a position of the first marker that is substantially the same as the position of the first localization element relative to the dynamic body and a position of the second marker that is substantially the same as the position of the second localization element relative to the dynamic body.

BRIEF DESCRIPTION OF THE DRAWINGS

[0008] The present invention is described with reference to the accompanying drawings.

[0009] FIG. 1 is a schematic illustration of various devices used with a method according to an embodiment of the invention.

[0010] FIG. 2 is a schematic illustration of various devices used with a method according to an embodiment of the invention.

[0011] FIG. 3 is a front perspective view of an apparatus according to an embodiment of the invention.

[0012] FIG. 4 is a graphical representation illustrating the function of an apparatus according to an embodiment of the invention.

[0013] FIG. 5 is a schematic illustration of an example of voxels of a connected-component in a 3-D volume according to an embodiment of the invention.

[0014] FIG. 6 is a schematic illustration of an example of voxels of a connected-component in a 3-D volume according to an alternative embodiment of the invention.

[0015] FIG. 7 is a flowchart illustrating a method according to an embodiment of the invention.

[0016] FIG. 8 is a schematic illustration of the flow of information during an automatic segmentation process.

DETAILED DESCRIPTION

[0017] A method according to an embodiment of the invention includes capturing images of a dynamic body during a path of motion of the dynamic body pre-procedurally (also referred to herein as "first time interval"). The images can be used to assist a physician in navigating a medical instrument to a desired location on the dynamic body during a medical procedure performed at a later time (also referred to herein as "second time interval"). The method uses a system configured to automatically perform segmentation, correlation and registration between data obtained in "model space" or "image space" (position data taken pre-procedurally) and data obtained in "physical space" (position data obtained during a later medical procedure).

[0018] Specifically, an apparatus is configured to be coupled to a selected dynamic body, such as selected dynamic anatomy of a patient. Dynamic anatomy can be, for example, any portion of the body associated with anatomy

that moves during its normal function (e.g., the heart, lungs, kidneys, liver and vasculature). The apparatus can include, for example, two or more markers configured to be coupled to a patient and two or more localization elements configured to be coupled to the patient proximate the markers. In other embodiments, the apparatus can include, for example, a garment configured to be coupled to a patient, two or more markers coupled to the garment, and two or more localization elements coupled to the garment at a location proximate the markers.

[0019] A processor, such as a computer, is configured to receive the pre-procedural image data associated with the dynamic body taken during a pre-surgical or pre-procedural first time interval. The image data can include an indication of a position of each of the markers for multiple instants in time during the first time interval. The processor can also receive position data associated with the localization elements during a second time interval in which a surgical procedure or other medical procedure is being performed. The processor can use the position data received from the localization elements and the position data received from the images to automatically identify an image from the pre-procedural images where the position of the markers at a given instant in time during the pre-procedural imaging is substantially the same as the position of the localization elements corresponding to those markers, at a given instant of time during the later medical procedure.

[0020] A physician or other healthcare professional can use the images that were automatically identified by the processor during a medical procedure performed during the second time interval, such as, for example, an image-guided medical procedure involving temporal registration and gated navigation. For example, when a medical procedure is performed on a targeted anatomy of a patient, such as a heart, the physician may not be able to utilize an imaging device during the medical procedure to guide him to the targeted area within the patient. Markers or fiducials can be positioned or coupled to the patient proximate the targeted anatomy prior to the medical procedure, and pre-procedural images can be taken of the targeted area during a first time interval. The markers or fiducials can be viewed within the image data, which can include an indication of the position of the markers during a given path of motion of the targeted anatomy (e.g., the heart) during the first time interval. Such motion can be due, for example, to inspiration (i.e., inhaling) and expiration (i.e., exhaling) of the patient, or due to the heart beating. During a medical procedure, performed during a second time interval, such as a procedure on a heart, with the markers coupled to the patient at the same location/position as during the first time interval, the processor receives data from the localization elements associated with a position of the localization elements at a given instant in time during the medical procedure (or second time interval).

[0021] Because the markers are positioned at the same location on the patient relative to the dynamic body during both the first time interval and the second time interval, and the localization elements are coupled to the patient proximate the location of the markers, a correlation can be made between the position data in image space and the position data in physical space. For example, a position of the markers at an instant in time during the pre-procedural imaging corresponds to a specific position and orientation of the dynamic body at an instant in time during the path of

motion of the dynamic body as viewed in the image data. When the medical procedure is performed during the second time interval, a position of the localization elements likewise corresponds to a specific positioning of the dynamic body at an instant in time during the path of motion of the dynamic body. Although the marker-localization element combinations can move relative to each other, for example, as the dynamic anatomy moves, the markers are in a fixed position relative to the patient during both the first time interval and the second time interval. As stated above, the localization elements are coupled to the patient proximate the markers, thus, when the position of the localization elements (identified during the medical procedure) is substantially the same as the position of the markers (identified in the image space), the image corresponding to that position of the markers is representative of the position of the dynamic body for that instant during the medical procedure.

[0022] An automatic segmentation-correlation-registration process can be performed after the image dataset is imported into the processor and the localization elements are connected to the processor. Once performed, the correlation does not change during the course of the procedure and the model space marker positions provide a baseline position for the temporal registration. After the segmentation-correlation and baseline registration has been computed, the localization element locations are sampled automatically and continuously to determine when the dynamic body is at or near the position at which the images were acquired. The affine rigid-body transformation is computed automatically and continuously until a temporal gating threshold is exceeded, indicating that the dynamic body is no longer near the same configuration as where the images were acquired. The automatic process produces simulated real-time, intra-procedural images illustrating the orientation and shape of the targeted anatomy as a catheter or similar structure is navigated to the targeted anatomy. Thus, during the medical procedure, the physician can view selected image(s) of the targeted anatomy that correspond to and simulate real-time movement of the anatomy.

[0023] In addition, during a medical procedure being performed during the second time interval, such as navigating an instrument, such as a catheter or needle to a targeted anatomy, the location(s) of an electromagnetic coil coupled to the instrumentation during the second time interval can be superimposed on an image of the instrumentation. The superimposed image(s) of the instrument can then be superimposed on the selected image(s) from the first time interval, providing simulated real time imaging of the instrument location relative to the targeted anatomy. This process and other related methods are described in pending U.S. patent application Ser. No. 10/273,598, entitled *Methods, Apparatuses, and Systems Useful in Conducting Image Guided Interventions*, filed Nov. 8, 2003, the entire disclosure of which is incorporated herein by reference.

[0024] Having described above various general principles, several example embodiments of these concepts are now described. These embodiments are only examples, and many other embodiments are contemplated by the principles of the invention, and will be apparent to the artisan in view of the general principles described above and the exemplary embodiments. For example, other possible embodiments can be used to perform some or all of the functions described herein, such as those systems and methods described in U.S.

patent application Ser. No. 11/224,028, filed Sep. 13, 2005, entitled "Apparatus and Method for Image Guided Accuracy Verification" (referred to herein as "the '028 application"), the disclosure of which is hereby incorporated by reference in its entirety.

[0025] FIGS. 1 and 2 are schematic illustrations of devices that can be used to perform various procedures described herein. An apparatus 10 includes two or more markers or fiducials 22 coupled to a dynamic body B at selected locations, as shown in FIG. 1. The dynamic body B can be, for example, a selected dynamic portion of the anatomy of a patient. The markers 22 are constructed of a material that can be viewed on an image, such as an X-ray. The markers 22 can be, for example, radiopaque, and can be coupled to the dynamic body B using known methods of coupling such devices to a patient, such as with adhesive, straps, etc. FIGS. 1 and 2 illustrate the apparatus 10 having four markers 22, but any number of two or more markers can be used.

[0026] An imaging device 40 can be used to take images of the dynamic body B while the markers 22 are coupled to the dynamic body B, pre-procedurally during a first time interval. As stated above, the markers 22 are visible on the images and can provide an indication of a position of each of the markers 22 during the first time interval. The position of the markers 22 at given instants in time through a path of motion of the dynamic body B can be illustrated with the images. The imaging device 40 can be, for example, a computed tomography (CT) device (e.g., respiratory-gated CT device, ECG-gated CT device), a magnetic resonance imaging (MRI) device (e.g., respiratory-gated MRI device, ECG-gated MRI device), an X-ray device, or any other suitable medical imaging device. In one embodiment, the imaging device 40 is a computed tomography—positron emission tomography device that produces a fused computed tomography—positron emission tomography image dataset. The imaging device 40 can be in communication with a processor 30 and send, transfer, copy and/or provide image data taken during the first time interval associated with the dynamic body B to the processor 30.

[0027] The processor 30 includes a processor-readable medium storing code representing instructions to cause the processor 30 to perform a process. The processor 30 can be, for example, a commercially available personal computer, or a less complex computing or processing device that is dedicated to performing one or more specific tasks. For example, the processor 30 can be a terminal dedicated to providing an interactive graphical user interface (GUI). The processor 30, according to one or more embodiments of the invention, can be a commercially available microprocessor. Alternatively, the processor 30 can be an application-specific integrated circuit (ASIC) or a combination of ASICs, which are designed to achieve one or more specific functions, or enable one or more specific devices or applications. In yet another embodiment, the processor 30 can be an analog or digital circuit, or a combination of multiple circuits.

[0028] The processor 30 can include a memory component 32. The memory component 32 can include one or more types of memory. For example, the memory component 32 can include a read only memory (ROM) component and a random access memory (RAM) component. The memory component can also include other types of memory that are

suitable for storing data in a form retrievable by the processor 30. For example, electronically programmable read only memory (EPROM), erasable electronically programmable read only memory (EEPROM), flash memory, as well as other suitable forms of memory can be included within the memory component. The processor 30 can also include a variety of other components, such as for example, co-processors, graphic processors, etc., depending upon the desired functionality of the code.

[0029] The processor 30 can store data in the memory component 32 or retrieve data previously stored in the memory component 32. The components of the processor 30 can communicate with devices external to the processor 30 by way of an input/output (I/O) component (not shown). According to one or more embodiments of the invention, the I/O component can include a variety of suitable communication interfaces. For example, the I/O component can include, for example, wired connections, such as standard serial ports, parallel ports, universal serial bus (USB) ports, S-video ports, local area network (LAN) ports, small computer system interface (SCSI) ports, and so forth. Additionally, the I/O component can include, for example, wireless connections, such as infrared ports, optical ports, Bluetooth® wireless ports, wireless LAN ports, or the like.

[0030] The processor 30 can be connected to a network, which may be any form of interconnecting network including an intranet, such as a local or wide area network, or an extranet, such as the World Wide Web or the Internet. The network can be physically implemented on a wireless or wired network, on leased or dedicated lines, including a virtual private network (VPN).

[0031] As stated above, the processor 30 can receive image data (also referred to herein as "image dataset") from the imaging device 40. The processor 30 can identify the position of selected markers 22 within the image data or voxel space using various segmentation techniques, such as Hounsfield unit thresholding, convolution, connected component, or other combinatory image processing and segmentation techniques. The processor 30 can determine a distance and direction between the position of any two markers 22 during multiple instants in time during the first time interval, and store the image data, as well as the position and distance data, within the memory component 32. Multiple images can be produced providing a visual image at multiple instants in time through the path of motion of the dynamic body. The processor 30 can also include a receiving device or localization device 34, which is described in more detail below.

[0032] As shown in FIG. 2, during a second time interval, two or more localization elements 24 are coupled to the markers 22 for use during a medical procedure to be performed during the second time interval. The localization elements 24 are coupled to the patient adjacent the markers 22. The localization elements 24 can be, for example, electromagnetic coils, infrared light emitting diodes, and/or optical passive reflective markers. The markers 22 can include plastic or non-ferrous fixtures or dovetails or other suitable connectors used to couple the localization elements 24 to the markers 22. A medical procedure can then be performed with the markers 22 coupled to the dynamic body B at the same location as during the first time interval when the pre-procedural images were taken. During the medical procedure, the localization elements 24 are in communica-

tion or coupled to the localization device **34** included within processor **30**. The localization device **34** can be, for example, an analog to digital converter that measures voltages induced onto localization coils in the field; creates a digital voltage reading; and maps that voltage reading to a metric positional measurement based on a characterized volume of voltages to millimeters from a fixed field emitter. Position data associated with the localization elements **24** can be transmitted or sent to the localization device **34** continuously during the medical procedure during the second time interval. Thus, the position of the localization elements **24** can be captured at given instants in time during the second time interval.

[0033] The image dataset, the position data for the markers from the first time interval (“model space”) and the position data for the localization elements during the second time interval (“physical space”) can be used to perform an automatic segmentation, correlation and registration between the data in the model space and the data in the physical space. The result of the analysis is to provide a physician with images that represent the position of a dynamic body during the second time interval when the physician is performing a medical procedure on the dynamic body. The processor **30** can be configured to perform the automatic segmentation-correlation-registration process as described in more detail below.

[0034] To identify actual position data associated with the markers **22** within the image dataset, the processor **30** can perform an automated segmentation procedure. Segmentation is the process of identifying reference points in the 3-D image dataset. The purpose of the segmentation is to automatically locate potential “landmarks” in the dataset that indicate a location where a marker **22** may be located. Segmentation can be performed in a variety of different manners. For example, a segmentation process can include, intensity filtering, connectivity analysis, and size and shape filtering to identify candidate sensor (e.g., marker) locations, or model space (also referred to herein as “image space”) coordinates of the marker **20** candidates. In some example embodiments, the intensity filtering applies domain knowledge to threshold the 3-D image dataset to select only those image values that fall within a designated intensity range that contains the reference points. For example, reference markers can be designated to appear in CT scans with Hounsfield units higher than the anatomical structures within the 3-D image. An example output from an intensity filtering process can include a 3-D binary volume with non-zero entries indicating voxels (i.e., a 3-D data point) with an intensity that falls within the range of values that characterize an image marker, as illustrated in FIG. **8**. FIG. **8** is a schematic illustration of the flow of information during one example of an automatic segmentation process.

[0035] After filtering the image values based on intensity, a connectivity analysis can be performed. A connectivity analysis can use the output from the intensity filtering to analyze the potential candidates identified in the 3-D image dataset to identify, for example, “connected-components.” A connected-component, as used here, is a continuous 3-D region in the 3-D volume (i.e., image dataset) that is connected via adjacent voxels that are in contact with one another. Examples of voxels of connected-components are illustrated in FIGS. **5** and **6**. FIG. **5** illustrates a connected-component having 8 connected voxel elements (indicated by

the shaded boxes), and FIG. **6** illustrates a connected component having 4 connected voxel elements (indicated by the shaded boxes). From the identified connected-components, information about the connected regions, such as the location of each voxel element, the geometric center, and the volume and bounding perimeter dimensions can be identified. An example output of a connectivity analysis can include, for example, a list of each separate connected-component in the 3-D binary volume, and can be used in the next step in the segmentation process.

[0036] Next, in some embodiments, the output from the connectivity analysis, which includes the identified connected-components, can be filtered based on size and shape criteria during a size threshold analysis. First, knowledge about the size of the reference markers can be used to identify and discard any connected-components that are too small or too large to be valid markers. A list of connected-components that fulfill the size criteria can then be evaluated based on the shape of the components during a shape-filtering analysis. Knowledge about the shape of the reference markers can be used to discard any components that do not match the known shape of the reference markers. For example, if the markers are known to be cylindrical, then the connected component shape can be analyzed to determine if the ratio between the major axis and the minor axis is within a set criteria. The output from this step in this example process includes, for example, a list of connected-components that fulfill the shape criteria. Other analysis can be performed depending on the particular marker configuration, such as, for example, checking whether the connected-component shape is symmetric about a centroid of the connected-component.

[0037] After the segmentation process is performed, an automatic correlation process can be performed. Correlation as used here is the process of correctly matching reference points between the image or model space and the physical space. Correctly matching the reference points aids in accurately computing the registration between the data in the image space and the data in the physical space without user interaction. The correlation process determines where each of the localization elements is positioned in the model images. Correct correlation is required to compute an affine transform between model space and physical space. The apparatuses and methods described herein enable the process to be automated with minimal user intervention. Automatic correlation results in an understanding of the location of the markers in image space and physical space, as well as the corresponding labeling/identification of each marker in each space.

[0038] Because there are a large number of possible solutions, computations of all possible combinations can result in long computation times. According to an embodiment of the invention, the processor **30** can be configured to compute the correlation between the image space and the physical space at a much faster rate (e.g., 2 seconds on a 1.5 GHz G4 Macintosh computer).

[0039] Because the number of localization element positions in the physical space is typically smaller than the number of identified marker positions in the model space, a guess at a correlation can be made for three localization element points in physical space. An affine transform registration is then computed between the selected positions of

the localization elements **24** in physical space and the model space. The computed registration is then used to transform the remaining localization element positions to model space and determine if any markers exist at the projected locations. A brute force iteration is made in groups of 3 as just described. When projecting the remaining points from physical space to model space to test the correlation guess, a test can be performed for the existence of a marker in model space within a settable threshold 3-D distance. If present, a 3-D error can be computed and the correlation resulting in the lowest error can be noted and recorded. This technique discards points in model space that do not have a corresponding point in physical space (i.e., false positives in the list of marker positions determined during segmentation).

[0040] Because the number of localization element positions is relatively low, it can be fairly computationally inexpensive to perform the iterative process described above to search all possible correlation combinations. The process is implemented such that the affine transform used to compute rigid body registration between the model space and the physical space for each 3-point correlation is abstract, and the actual implementation can be defined and determined at runtime. It is possible to improve the speed of the process by stopping the solution search iterations if a solution is identified that meets the specified criteria. For example, when computing the error for a correlation guess, the projection loop-and-fail for the correlation guess can be reduced if any single reference point in the physical space fails to map to a point in model space within a specified error threshold. Each potential correlation combination is evaluated by one or more criteria to determine the correlation between segmented markers in model space and physical localization element locations. Examples of evaluation criteria include computing the transformation using three points, and then projecting the remaining physical points to model space as described previously. Other examples include incorporating coil orientation information between the segmented markers and 5- or 6-degrees of freedom (DOF) localization elements, or applying externally available information, such as requiring the user to attach the localization elements in a certain configuration. This correlation technique can account for physical localization elements being in a slightly different relative position than the model space markers since the localization elements process can be performed when the localization elements are anywhere in the periodic cycle of the dynamic body.

[0041] After the correlation process, the processor **30** can perform an automatic registration process. The process of registration tracks temporal movement of the dynamic body via the movement of the markers **22**, and when temporally valid, computes the transformation between the physical space and the model space.

[0042] A measure of a temporal position is referred to herein as a "cost-function." An automatic registration algorithm uses abstract objects so that the cost-function can be defined/determined at runtime. For example, one possible cost function is the average distance between reference points (e.g., positions of localization elements **24**). Cost-functions can compute a temporal measure for a group of reference points independent of the space in which the points are known since the measure is based upon landmark positions relative to each other. Once the correlation is

established, the localization element locations in physical space can be periodically evaluated using a cost-function to determine when the dynamic body most closely matches the point in the periodic phase of the first time interval (image acquisition). Examples of cost-functions can include: average distance between markers; max/min axis ratio of bounding ellipsoid; and a ratio between minimum and maximum 3D distance between markers. The cost-function can be, for example, determined in patient model space to ensure that moving the patient and/or localizing machinery will not affect the outcome/solution/computation.

[0043] A cost-function can be used to establish a measure of the marker positions within the plurality of images during the first time interval. The same cost-function can then be applied continuously to the correlated localization element positions during the second time interval. When the cost-function indicates that the positions of the localization elements in the second time interval have the same relative positions as the marker positions in the first time interval, then the dynamic body can be identified as being at the same temporal point along the path of motion as the first time interval. During the time that the cost-function indicates that the dynamic body is at the same temporal point along the path of motion as the first time interval, then the automatically correlated markers from the first time interval and localization elements from the second time interval can be used to automatically compute a registration. When the cost-function indicates that the registration is valid, then the position and navigational path of a medical instrument can be displayed on a computer screen superimposed onto images of the dynamic body acquired during the first time interval.

[0044] After performing the automated segmentation and correlation processes, a list of position data for the localization elements **24** in image space is obtained. This represents the position of the markers **22**, and therefore the position of the dynamic body B when the image dataset was acquired. This information is used as the "temporal reference" for the image dataset and represents the nominal reference point position for the dataset. For multiple images acquired at different points in the patient temporal cycle (e.g., at inspiration and expiration of the respiratory cycle), the segmentation-correlation process can be repeated and a temporal reference position can be determined for each image.

[0045] Once the temporal reference is established for each image dataset, a registration filter can be used to compare the position of the localization elements **24** in the physical space to the temporal reference location for each image dataset. If the positions of the localization elements **24** are sufficiently close to the temporal reference for a dataset (i.e., the image dataset), then the dataset can be used for navigation for that temporal moment by computing the affine transformation between the physical space and model space. The transformation is then used to project information such as reformatted images, segmentations, informatics, etc. The threshold that determines how close the physical configuration must be to the locations in the image dataset can be modified at runtime to allow the sensitivity or temporal resolution to be modified.

[0046] Through the automatic registration process, the relative marker positions at the time of the 3-D scan can be

determined. This acquisition of relative marker position allows the point in the respiratory cycle at which the scan was acquired to be determined and navigation gated to that same point in the cycle during a subsequent medical procedure. The resulting registration is relative to the markers affixed to the patient, which allows the patient to be repositioned relative to the scan gantry, table position, and/or localization machinery without invalidating the registration, as long as the markers remain in a fixed position relative to the patient.

[0047] As stated previously, the automatic segmentation-correlation-registration process can be performed using an apparatus that includes a garment, such as a garment disclosed in the '028 application. Such an apparatus can be used with the systems and methods described herein to perform the same automatic-segmentation-registration processes described above, except in such an embodiment, the markers and localization elements are coupled to the patient through the use of a garment. All other devices described with reference to FIGS. 1 and 2 can be used in this embodiment to perform the same automatic segmentation-correlation-registration processes as described above.

[0048] FIG. 3 illustrates an apparatus 210 that includes a garment 220 that is tubular shaped and can be constructed with a flexible and/or stretchable material. This particular garment configuration is only one example of a garment that can be used. It should be understood that other garment configurations can alternatively be used, such as those described in the '028 application. The apparatus 210 further includes multiple markers or fiducials 222 coupled to the garment 220 at spaced locations. A plurality of localization elements 224 are removably coupled proximate to the locations of markers 222, such that during a first time interval as described above, images can be taken without the elements 224 being coupled to the garment 220. In other embodiments, the localization elements 224 need not be removably coupled to the markers 222. For example, the localization elements 224 can be fixedly coupled to the garment 220. In addition, the localization elements 224 can be coupled to the garment 220 during the pre-procedure imaging.

[0049] The garment 220 can be positioned over a portion of a patient's body (proximate dynamic anatomy), such as around the upper or lower torso of the patient at a fixed location relative to the patient during both a first time period, in which images are taken of the dynamic anatomy (model or image space), and during a second time period, in which a medical procedure is being performed on the dynamic anatomy (physical space). The stretchability of the garment 220 allows the garment 220 to at least partially constrict some of the movement of the portion of the body for which it is coupled. The markers 222 are coupled to the garment 220 at a fixed location on the garment 220, thus the markers 222 are also coupled to the patient at a fixed location relative to the dynamic anatomy during both the first time period and the second time period.

[0050] FIG. 4 is a graphical illustration indicating how the apparatus 210 (shown without localization elements 224) can move and change orientation and shape during movement of a dynamic body, such as a mammalian body M. The graph is one example of how the lung volume can change during inhalation (inspiration) and exhalation (expiration) of the mammalian body M. The corresponding changes in

shape and orientation of the apparatus 210 during inhalation and exhalation are also illustrated. Although FIG. 4 is being described with reference to an embodiment including a garment, an embodiment that does not include a garment can be similarly described. The six markers 222 shown in FIG. 3 are labeled a, b, c, d, e, and f. As described above, images of the dynamic anatomy with the apparatus 210 coupled thereto can be taken during a first time interval. The images can include an indication of relative position of each of the markers 222, that is the markers 222 are visible in the images, and the position of each marker 222 can then be identified over a period of time. As illustrated, during expiration of the mammalian body M at times indicated as A and C, a distance X between markers a and b is smaller than during inspiration of the mammalian body M, at the time indicated as B. Likewise, a distance Y between markers b and f is greater during inspiration than during expiration.

[0051] FIG. 7 is a flowchart illustrating a method according to another embodiment of the invention. A method includes at step 80 receiving during a first time interval image data associated with a plurality of images of a dynamic body. The plurality of images include an indication of a position of a first marker on a garment coupled to the dynamic body and a position of a second marker on the garment coupled to the dynamic body. The first marker is coupled to the garment at a first location and the second marker is coupled to the garment at a second location. The first time interval is associated with a path of motion of the dynamic body. At step 82, data associated with a position of a first localization element relative to the dynamic body is received, and data associated with a position of a second localization element relative to the dynamic body is received during a second time interval after the first time interval. The first localization element is coupled to the garment at the first location, and the second localization element is coupled to the garment at the second location. The second time interval is associated with a path of motion of the dynamic body and the garment is coupled to the dynamic body in a fixed position relative to the dynamic body during both the first time interval and the second time interval.

[0052] During the second time interval, an image from the plurality of images associated with a position of the first marker that is substantially the same as the position of the first localization element relative to the dynamic body and a position of the second marker that is substantially the same as the position of the second localization element relative to the dynamic body are automatically identified at step 84. The automatic identification can be based on an appearance of the markers within the identified image. The automatic identification can also include identifying a position of a third localization element, and projecting that position on to the image data set and determining whether a third marker exists in an image from the image data set at the position of the third localization element. The automatic identification can also include correlating a position of the first localization element during the second time interval with the position of the first marker in the plurality of images. At step 86, the path of motion of the dynamic body is automatically registered during the second time interval is automatically registered with the path of motion of the dynamic body during the first time interval. The automatic registering in step 86 can include identifying at least one temporal reference within the plurality of images and identifying whether the at least one temporal reference is associated with at least

one of the first marker or the second marker providing a navigational path for a medical instrument to be directed based on the identified image.

[0053] At step 88, a navigational path is provided for a medical instrument to be directed based on the identified image. A physician can use the navigational path to guide a medical instrument to the dynamic body while performing a medical procedure on the dynamic body during the second time interval.

CONCLUSION

[0054] While various embodiments of the invention have been described above, it should be understood that they have been presented by way of example only, and not limitation. Thus, the breadth and scope of the invention should not be limited by any of the above-described embodiments, but should be defined only in accordance with the following claims and their equivalents.

[0055] The previous description of the embodiments is provided to enable any person skilled in the art to make or use the invention. While the invention has been particularly shown and described with reference to embodiments thereof, it will be understood by those skilled in art that various changes in form and details may be made therein without departing from the spirit and scope of the invention. For example, the garment, markers and localization elements can be constructed from any suitable material, and can be a variety of different shapes and sizes, not necessarily specifically illustrated, while still remaining within the scope of the invention.

[0056] While a relatively small number of markers are discussed, the system is scalable and the use of any number of markers is contemplated. For example, a garment may include between 2 and 20 markers, 10-50 markers, etc. Additionally, variations in the automated processes can be used to achieve the same, or substantially the same, desired results.

What is claimed is:

1. A method, comprising:

receiving during a first time interval image data associated with a plurality of images of a dynamic body, the plurality of images including an indication of a position of a first marker on a garment coupled to the dynamic body and a position of a second marker on the garment coupled to the dynamic body, the first marker coupled to the garment at a first location, the second marker coupled to the garment at a second location, the first time interval associated with a path of motion of the dynamic body;

receiving during a second time interval after the first time interval data associated with a position of a first localization element relative to the dynamic body, and data associated with a position of a second localization element relative to the dynamic body, the first localization element coupled to the garment at the first location, the second localization element coupled to the garment at the second location, the second time interval associated with a path of motion of the dynamic body; and

automatically identifying during the second time interval an image from the plurality of images associated with a position of the first marker that is substantially the same as the position of the first localization element relative to the dynamic body and a position of the second marker that is substantially the same as the position of the second localization element relative to the dynamic body.

2. The method of claim 1, wherein the automatically identifying includes identifying a position of the first marker based on an appearance of the first marker within the identified image and identifying a position of the second marker based on an appearance of the second marker within the identified image.

3. The method of claim 1, further comprising:

receiving during the second time interval data associated with a position of a third localization element relative to the dynamic body, the third localization element coupled to the dynamic body;

projecting the position of the third localization element on to the data associated with a plurality of images; and

determining that a third marker either one of exists or does not exist in an image from the plurality of images from the first time interval at substantially the same position as the third localization element.

4. The method of claim 1, wherein the automatically identifying includes correlating the position of the first localization element during the second time interval with the position of the first marker within an image from the plurality of images.

5. The method of claim 1, further comprising:

automatically registering the path of motion of the dynamic body during the second time interval with the path of motion of the dynamic body during the first time interval based on the automatically identifying.

6. The method of claim 1, further comprising:

automatically identifying includes determining a measurement between the position of the first marker and the position of the second-marker associated with the plurality of images during the first time interval using a selected cost-function;

applying the selected cost-function to the position of the first localization element and the position of the second localization element during the second time interval;

determining whether the position of the first localization element and the position of the second localization element during the second time interval is substantially the same as the position of the first marker and the position of the second marker, respectively, during the first time interval;

automatically computing a registration between the positions of the first and second markers, and the positions of the first and second localizations elements; and

superimposing a position of a medical instrument on to an image display of the dynamic body from the first time interval.

7. The method of claim 1, wherein the garment is coupled to the dynamic body in a fixed position relative to the dynamic body during both the first time interval and the second time interval.

8. The method of claim 1, further comprising:

providing a navigational path for a medical instrument to be directed based on the identified image.

9. The method of claim 1, wherein the first marker and the second marker are coupled to the dynamic body in a fixed position relative to the dynamic body, but can move relative to each other when the dynamic body moves through a path of motion, the first localization element and the second localization element are coupled to the dynamic body at a fixed position relative to the dynamic body, but can move relative to each other when the dynamic body moves through a path of motion.

10. A processor-readable medium storing code representing instructions to cause a processor to perform a process, the code comprising code to:

receive during a first time interval image data associated with a plurality of images of a dynamic body, the plurality of images including an indication of a position of a first marker on a garment coupled to the dynamic body and a position of a second marker on the garment coupled to the dynamic body, the first marker coupled to the garment at a first location, the second marker coupled to the garment at a second location;

receive during a second time interval after the first time interval data associated with a position of a first localization element relative to the dynamic body, and data associated with a position of a second localization element relative to the dynamic body, the first localization element coupled to the garment at the first location, the second localization element coupled to the garment at the second location, the second time interval associated with a path of motion of the dynamic body; and

automatically identify during the second time interval an image from the plurality of images including a position of the first marker that is substantially the same as the position of the first localization element relative to the dynamic body and a position of the second marker that is substantially the same as the position of the second localization element relative to the dynamic body.

11. The processor-readable medium of claim 10, wherein the automatically identifying includes code to:

identify a position of the first marker based on an appearance of the first marker within the identified image and identifying a position of the second marker based on an appearance of the second marker within the identified image.

12. The processor-readable medium of claim 10, further comprising code to:

receive during the second time interval data associated with a position of a third localization element relative to the dynamic body, the third localization element coupled to the dynamic body;

project the position of the third localization element on to the data associated with a plurality of images; and

determine that a third marker either one of exists or does not exist in an image from the plurality of images from the first time interval at substantially the same position as the third localization element.

13. The processor-readable medium of claim 10, wherein the automatically identifying includes correlating the position of the first localization element during the second time interval with the position of the first marker within an image from the plurality of images.

14. The processor-readable medium of claim 10, further comprising code to:

automatically register the path of motion of the dynamic body during the second time interval with the path of motion of the dynamic body during the first time interval, based on the automatically identifying.

15. The processor-readable medium of claim 10, further comprising code to:

determine a measurement between the position of the first marker and the position of the second marker associated with the plurality of images during the first time interval using a selected cost-function;

apply the selected cost-function to the position of the first localization element and the position of the second localization element during the second time interval;

determine whether the position of the first localization element and the position of the second localization element during the second time interval is substantially the same as the position of the first marker and the position of the second marker, respectively, during the first time interval;

automatically compute a registration between the positions of the first and second markers, and the positions of the first and second localization elements; and

superimpose a position of a medical instrument on to an image display of the dynamic body from the first time interval.

16. The processor-readable medium of claim 10, wherein the garment is coupled to the dynamic body in a fixed position relative to the dynamic body during both the first time interval and the second time interval.

17. The processor-readable medium of claim 10, further comprising:

providing a navigational path for a medical instrument to be directed based on the identified image.

18. The processor-readable medium of claim 10, wherein the first marker and the second marker are coupled to the dynamic body in a fixed position relative to the dynamic body, but can move relative to each other when the dynamic body moves through a path of motion, the first localization element and the second localization element are coupled to the dynamic body at a fixed position relative to the dynamic body, but can move relative to each other when the dynamic body moves through a path of motion.

19. A processor-readable medium storing code representing instructions to cause a processor to perform a process, the code comprising code to:

receive during a first time interval image data associated with a plurality of 3-D images of a dynamic body during a path of motion of the dynamic body, the dynamic body having a garment coupled to the dynamic body, the garment having a plurality of markers coupled thereto;

receive during a second time interval after the first time interval data associated with a plurality of localization

elements coupled to the garment, the data including a position of each of the plurality of localization elements during a path of motion of the dynamic body;

automatically compare the data associated with the position of each of the localization elements from the plurality of localization elements with a position of each marker from the plurality of markers identified from the data associated with a plurality of 3-D images; and

automatically identifying a marker from the plurality of markers within the plurality of 3-D images having substantially the same position as a localization element from the plurality of localization elements relative to the dynamic body based on the comparing.

20. The processor-readable medium of claim 19, further comprising code to:

select an image from the plurality of images associated with the identified marker.

21. The processor-readable medium of claim 19, further comprising code to:

automatically identify a second marker from the plurality of markers within the plurality of 3-D images having substantially the same position as a second localization element from the plurality of localization elements relative to the dynamic body based on the comparing; and

select an image from the plurality of 3-D images associated with the identified first marker and the identified second marker.

22. The processor-readable medium of claim 19, further comprising code to:

receive during the second time interval data associated with a position of a third localization element relative to the dynamic body, the third localization element coupled to the dynamic body;

project the position of the third localization element on to the data associated with a plurality of images; and

determine that a third marker either one of exists or does not exists in an image from the plurality of images at substantially the same position as the third localization element.

23. The processor-readable medium of claim 19, wherein the automatically identifying includes automatically correlating the identified position of the localization element with a position of the marker within an image from the plurality of images.

24. The processor-readable medium of claim 19, further comprising code to:

automatically register the path of motion of the dynamic body associated with the second time interval with the path of motion of the dynamic body associated with the first time interval, based on the automatically identifying.

25. A processor-readable medium storing code representing instructions to cause a processor to perform a process, the code comprising code to:

receive during a first time interval image data associated with a plurality of 3-D images of a dynamic body during a path of motion of the dynamic body, the dynamic body having an apparatus coupled thereto, the apparatus having a plurality of markers coupled thereto;

receive during a second time interval after the first time interval data associated with a plurality of localization elements coupled to the apparatus, the data including a position of each of the plurality of localization elements during a path of motion of the dynamic body;

automatically segment the data associated with a plurality of 3-D images from the first time interval to identify a position of each of the at least one markers from the plurality of markers;

automatically correlate the data associated with the position of the at least one markers from the plurality of markers from the first time interval with the data associated with the position of each of the localization elements from the plurality of localization elements from the second time interval; and

automatically register a path of motion of the dynamic body during the first time interval with a path of motion of the dynamic body during the second time interval based on the automatically correlating.

26. A method, comprising:

receiving during a first time interval image data associated with a plurality of images of a dynamic body, the plurality of images including an indication of a position of a first marker coupled to the dynamic body and a position of a second marker coupled to the dynamic body, the first marker coupled to the dynamic body at a first location, the second marker coupled to the dynamic body at a second location, the first time interval associated with a path of motion of the dynamic body;

receiving during a second time interval after the first time interval data associated with a position of a first localization element relative to the dynamic body, and data associated with a position of a second localization element relative to the dynamic body, the first localization element coupled to the dynamic body proximate the first location, the second localization element coupled to the dynamic body proximate the second location, the second time interval associated with a path of motion of the dynamic body; and

automatically identifying during the second time interval an image from the plurality of images associated with a position of the first marker that is substantially the same as the position of the first localization element relative to the dynamic body and a position of the second marker that is substantially the same as the position of the second localization element relative to the dynamic body.

* * * * *