



US00D660436S

(12) **United States Design Patent**
Dupray

(10) **Patent No.:** **US D660,436 S**

(45) **Date of Patent:** **** May 22, 2012**

(54) **ORTHODONTIC BRACKET**

(75) Inventor: **Dennis J. Dupray**, Golden, CO (US)

(73) Assignee: **RMO, Inc.**, Denver, CO (US)

(**) Term: **14 Years**

(21) Appl. No.: **29/391,894**

(22) Filed: **May 13, 2011**

(51) **LOC (9) Cl.** **24-99**

(52) **U.S. Cl.** **D24/180**

(58) **Field of Classification Search** D24/155-156,
D24/176, 180; 433/8-18

See application file for complete search history.

(56) **References Cited**

U.S. PATENT DOCUMENTS

1,890,487 A	12/1932	Angle
3,028,671 A	4/1962	Berger
3,391,461 A	7/1968	Johnson
3,435,527 A	4/1969	Kesling
3,494,034 A	2/1970	Kesling
3,496,637 A	2/1970	Etengoff
3,504,438 A	4/1970	Wittman et al.
3,526,961 A	9/1970	Kesling
3,765,091 A	10/1973	Northcutt
3,838,514 A	10/1974	Polak
3,854,207 A	12/1974	Wildman
3,874,080 A	4/1975	Wallshein
3,922,787 A	12/1975	Fischer et al.
3,930,311 A	1/1976	Andrews
3,964,156 A	6/1976	Williams et al.
3,969,821 A	7/1976	Lee, Jr. et al.
4,028,809 A	6/1977	Wallshein
4,063,360 A	12/1977	Waller
4,094,068 A	6/1978	Schinhammer
4,103,423 A	8/1978	Kessel
4,134,208 A	1/1979	Pearlman
4,165,561 A	8/1979	Miller et al.
4,172,999 A	10/1979	Leidich
4,193,195 A	3/1980	Merkel et al.
4,197,642 A	4/1980	Wallshein
4,219,617 A	8/1980	Wallshein

D256,950 S	9/1980	Sable
4,242,085 A	12/1980	Wallshein
4,243,386 A	1/1981	Kawaguchi

(Continued)

FOREIGN PATENT DOCUMENTS

DE 2534368 2/1977

(Continued)

OTHER PUBLICATIONS

“Brinellium—A Harder, Stronger, and More Wetttable Form of Aluminum Oxide,” Technical Advances, Materials Technology, Mar./Apr. 1993, vol. 8(3/4), pp. 44-45.

(Continued)

Primary Examiner — Wan Laymon

(74) *Attorney, Agent, or Firm* — Sheridan Ross P.C.

(57) **CLAIM**

The ornamental design for an orthodontic bracket, as shown and described.

DESCRIPTION

FIG. 1 is a perspective view of an orthodontic bracket showing the new design;
FIG. 2 is a top plan view thereof;
FIG. 3 is a bottom plan view thereof;
FIG. 4 is a front elevation view thereof;
FIG. 5 is a rear elevation view thereof;
FIG. 6 is a left elevation view thereof;
FIG. 7 is a right elevation view thereof;
FIG. 8 is a top plan view of the orthodontic bracket wherein a swivel clip is shown in a second position of use; and,
FIG. 9 is a top plan view of the orthodontic bracket wherein the swivel clip is shown in a third position of use.
The broken lines shown in the figures represent portions of the orthodontic bracket that form no part of the claimed design.

1 Claim, 9 Drawing Sheets

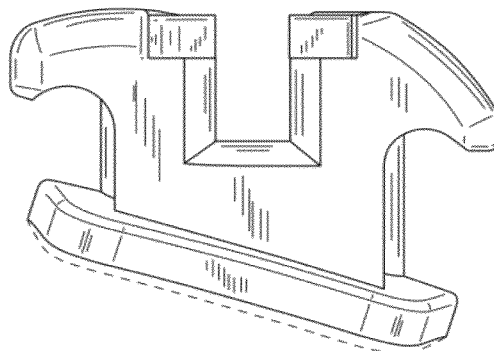
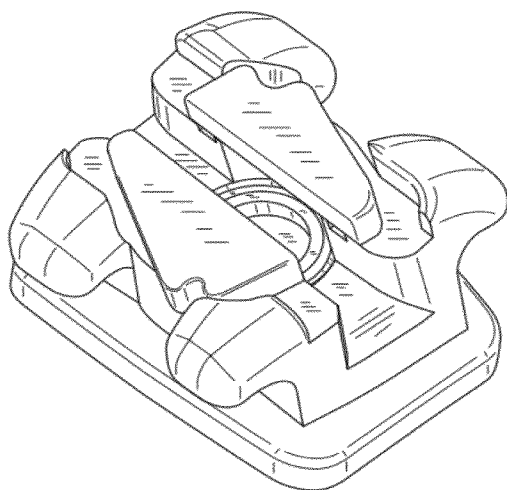

US D660,436 S

U.S. PATENT DOCUMENTS							
4,260,375	A	4/1981	Wallshein	D331,975	S	12/1992	Pospisil
4,299,569	A	11/1981	Frantz	5,203,804	A	4/1993	Nikutowski et al.
4,302,532	A	11/1981	Wallshein	5,226,814	A	7/1993	Allen
4,322,206	A	3/1982	Reynolds	5,230,620	A	7/1993	Watanabe
4,354,834	A	10/1982	Wilson	5,232,361	A	8/1993	Sachdeva et al.
4,386,908	A	6/1983	Kurz	5,238,402	A	8/1993	Rohlcke et al.
4,415,330	A	11/1983	Daisley et al.	5,242,299	A	9/1993	Yoshida
4,419,078	A	12/1983	Pletcher	D340,523	S	10/1993	Barngrover
4,430,061	A	2/1984	Webb et al.	5,252,066	A	* 10/1993	Fairhurst 433/8
4,443,190	A	4/1984	Kurz	5,254,002	A	10/1993	Reher et al.
4,478,577	A	10/1984	Warren, Jr.	5,256,062	A	10/1993	Griott
4,487,580	A	12/1984	Ridgeway	5,267,854	A	12/1993	Schmitt
4,498,867	A	2/1985	Kesling	5,267,855	A	12/1993	Tuneberg
4,527,975	A	7/1985	Ghafari et al.	5,269,680	A	12/1993	Kawaguchi
4,529,382	A	7/1985	Creekmore	5,277,581	A	1/1994	Peterson
4,531,911	A	7/1985	Creekmore	5,282,743	A	2/1994	Miura
4,531,991	A	7/1985	Ziemek et al.	5,288,229	A	2/1994	Huff et al.
4,536,154	A	8/1985	Garton, Jr. et al.	5,292,248	A	3/1994	Schultz
4,544,353	A	10/1985	Maurer et al.	5,295,823	A	3/1994	Farzin-Nia
4,545,760	A	10/1985	Forster	5,299,934	A	4/1994	Suyama
4,582,487	A	4/1986	Creekmore	5,302,117	A	4/1994	Kraut et al.
4,604,057	A	8/1986	Viglietti	5,302,121	A	4/1994	Gagin
4,626,209	A	12/1986	Tsai et al.	5,318,440	A	6/1994	Adam et al.
4,639,218	A	* 1/1987	Jones et al. 433/8	5,320,525	A	6/1994	Forster
4,659,309	A	4/1987	Merkel	5,320,526	A	6/1994	Tuneberg
4,661,059	A	4/1987	Kanno	5,322,435	A	6/1994	Pletcher
D290,040	S	5/1987	Kelly	5,362,232	A	11/1994	Franseen et al.
4,669,981	A	6/1987	Kurz	5,362,233	A	11/1994	Thompson
4,681,538	A	* 7/1987	DeLuca et al. 433/9	5,376,002	A	12/1994	Andreiko
D291,919	S	9/1987	Reynolds	D358,649	S	5/1995	Moschik
4,712,999	A	12/1987	Rosenberg	D358,650	S	5/1995	Moschik
4,717,341	A	1/1988	Goldberg et al.	D359,776	S	6/1995	Hilgers
4,735,569	A	4/1988	Munk	5,425,640	A	6/1995	Scharf
4,752,221	A	6/1988	Hanson et al.	5,441,408	A	8/1995	Moschik
4,773,853	A	9/1988	Kussick	5,441,409	A	8/1995	Tuneberg
4,781,334	A	11/1988	Derichs	5,443,384	A	8/1995	Franseen et al.
4,781,582	A	11/1988	Kesling	5,454,716	A	10/1995	Banerjee et al.
4,793,804	A	12/1988	Schudy	5,456,599	A	10/1995	Hanson
4,799,882	A	1/1989	Kesling	5,470,228	A	11/1995	Franseen et al.
4,819,316	A	4/1989	Rossini et al.	5,522,725	A	6/1996	Jordan et al.
4,820,151	A	4/1989	Pospisil	5,556,277	A	9/1996	Yawata et al.
4,838,786	A	6/1989	Reher et al.	5,588,833	A	12/1996	Risse
4,842,512	A	6/1989	Kesling	5,595,484	A	1/1997	Orikasa et al.
4,854,866	A	8/1989	Wilson	5,597,302	A	1/1997	Pospisil et al.
4,859,179	A	8/1989	Kesling	5,607,301	A	3/1997	Roman
4,902,224	A	2/1990	Collins et al.	5,616,026	A	4/1997	Cash
4,917,602	A	4/1990	Broussard	5,618,174	A	4/1997	Mors
4,927,362	A	5/1990	Snead	5,618,175	A	4/1997	Reher et al.
4,936,773	A	6/1990	Kawaguchi	5,622,494	A	4/1997	Andreiko et al.
4,954,080	A	9/1990	Kelly et al.	5,653,588	A	8/1997	Moschik
4,963,092	A	10/1990	Snead	5,685,711	A	11/1997	Hanson
4,975,052	A	12/1990	Spencer et al.	5,692,898	A	12/1997	Orikasa et al.
4,988,293	A	* 1/1991	Collins et al. 433/8	5,707,231	A	1/1998	Watt et al.
4,997,182	A	3/1991	Kussick	5,711,666	A	* 1/1998	Hanson 433/11
5,011,403	A	4/1991	Sadoun et al.	5,727,941	A	3/1998	Kesling
5,022,854	A	6/1991	Broughton et al.	5,729,768	A	3/1998	Fields et al.
5,030,089	A	7/1991	Kawaguchi	5,746,592	A	5/1998	Nezu et al.
5,044,945	A	9/1991	Peterson	5,746,594	A	5/1998	Jordan et al.
5,057,012	A	10/1991	Kesling	RE35,863	E	7/1998	Sachdeva et al.
5,059,119	A	10/1991	Snead	5,779,470	A	7/1998	Kussick
5,062,794	A	11/1991	Miura	5,810,583	A	9/1998	Doyle
5,066,225	A	11/1991	Forbes Jones et al.	5,816,801	A	* 10/1998	Farzin-Nia et al. 433/8
5,067,897	A	11/1991	Tuneberg	5,829,972	A	11/1998	Farzin-Nia
D322,482	S	12/1991	Ianieri et al.	5,857,849	A	1/1999	Kurz
5,071,344	A	12/1991	Wong et al.	5,871,350	A	2/1999	Clark et al.
5,078,596	A	1/1992	Carberry et al.	5,885,073	A	3/1999	Kussick
5,095,602	A	3/1992	Reher et al.	5,885,074	A	3/1999	Hanson
5,098,288	A	3/1992	Kesling	5,890,891	A	4/1999	Doyle
5,125,831	A	6/1992	Pospisil	5,908,293	A	6/1999	Voudouris
5,125,832	A	6/1992	Kesling	5,915,550	A	6/1999	Gartz
5,127,828	A	7/1992	Suyama	6,053,729	A	4/2000	Brehm et al.
5,133,740	A	7/1992	Kussick	6,086,364	A	7/2000	Brunson
5,145,365	A	* 9/1992	Farzin-Nia et al. 433/8	6,109,916	A	8/2000	Wilcko et al.
5,151,028	A	9/1992	Snead	6,126,441	A	10/2000	Tenti
5,154,607	A	10/1992	Hanson	6,190,165	B1	2/2001	Andreiko et al.
5,158,452	A	10/1992	Franseen et al.	6,193,508	B1	2/2001	Georgakis
5,160,261	A	11/1992	Peterson	6,206,690	B1	3/2001	Vargas
5,161,969	A	11/1992	Pospisil et al.	6,217,322	B1	4/2001	Kesling
				6,220,857	B1	4/2001	Abels

6,227,849 B1	5/2001	Brehm et al.	2008/0160474 A1	7/2008	Wolf et al.	
6,264,469 B1	7/2001	Moschik	2010/0151403 A1*	6/2010	Tuneberg et al.	433/10
6,280,185 B1	8/2001	Palmer et al.	2010/0178629 A1*	7/2010	Oda et al.	433/14
6,347,939 B2	2/2002	Abels				
6,394,798 B1	5/2002	Huff et al.				
6,428,314 B1	8/2002	Jones, Jr. et al.				
6,461,157 B1	10/2002	Kussick				
6,478,579 B1	11/2002	Brusse				
6,491,519 B1	12/2002	Clark et al.				
6,607,383 B2	8/2003	Abels et al.				
6,616,445 B2	9/2003	Abels et al.				
6,655,957 B2	12/2003	Abels et al.				
6,655,958 B2	12/2003	Abels et al.				
6,656,767 B1	12/2003	King et al.				
6,659,766 B2	12/2003	Abels et al.				
6,659,767 B2	12/2003	Abels et al.				
6,695,612 B2	2/2004	Abels et al.				
6,705,862 B2	3/2004	Schultz				
6,709,268 B2	3/2004	Pospasil et al.				
6,733,286 B2	5/2004	Abels et al.				
6,776,613 B2	8/2004	Orikasa				
6,846,178 B2	1/2005	Freeman, Jr. et al.				
D504,950 S *	5/2005	Lai et al.	D24/180			
6,893,257 B2	5/2005	Kelly				
6,910,884 B2	6/2005	Kelly et al.				
6,913,459 B2	7/2005	Fukutomi				
7,025,591 B1	4/2006	Kesling				
7,033,171 B2	4/2006	Wilkerson				
7,192,274 B2*	3/2007	Stadtmiller et al.	433/8			
7,210,927 B2	5/2007	Abels et al.				
7,234,935 B2	6/2007	Abels et al.				
7,481,651 B2*	1/2009	Sernetz et al.	433/10			
7,695,277 B1	4/2010	Stevens				
7,959,437 B2	6/2011	Zakhem et al.				
8,033,824 B2*	10/2011	Oda et al.	433/11			
2002/0110778 A1	8/2002	Abels et al.				
2002/0187452 A1	12/2002	Abels et al.				
2003/0049582 A1	3/2003	Abels et al.				
2005/0003320 A1	1/2005	Freeman et al.				
2005/0244777 A1	11/2005	Schultz				
2006/0046224 A1	3/2006	Sondhi et al.				
2007/0264606 A1	11/2007	Muha				
2008/0081310 A1	4/2008	Smith et al.				

FOREIGN PATENT DOCUMENTS

DE	2903768	8/1980
DE	8903611	8/1990
DE	69228472	10/1999
EP	0317098	5/1989
EP	0379668	8/1990
EP	0389223	9/1990
EP	0397533	11/1990
EP	0577398	6/1993
EP	0588961	3/1994
EP	0875211	11/1998
EP	1332727	8/2003
EP	1359859	11/2003
ES	2130174	7/1999
FR	2497657	7/1982
JP	64-25847	1/1989
JP	01-160547	6/1989
JP	02-147112	6/1990
JP	03-21236	1/1991
JP	2579431	2/1997
JP	11-276504	10/1999
WO	WO 91/07925	6/1991
WO	WO 92/20296	11/1992
WO	WO 2004/039276	5/2004

OTHER PUBLICATIONS

“Direct Bond Tubes,” American Orthodontics, date unknown, p. 76.
 “Focus on Brackets,” Orthodontic Products, Mar. 2005, pp. 1-2.
 3M Unitek Corporation Catalog, 1990, pp. 1-1, 1-3, 3-7, Figs. A, B.
 Milewski, John V., “Efficient Use of Whiskers in the Reinforcement of Ceramics,” Advanced Ceramics, vol. 1(1), 1986, pp. 36-41.
 Ortho Organizers, Inc. Advertisement, “The Supreme™ Mini-Twin ®,” Journal of Clinical Orthodontics, Sep. 1989, 3 pages.
 Ricketts, “Provocations and Perceptions in Cranio-Facial Orthopedics,” RMO, Inc., Denver, CO, USA, 1989, cover and pp. 982-1021.

* cited by examiner

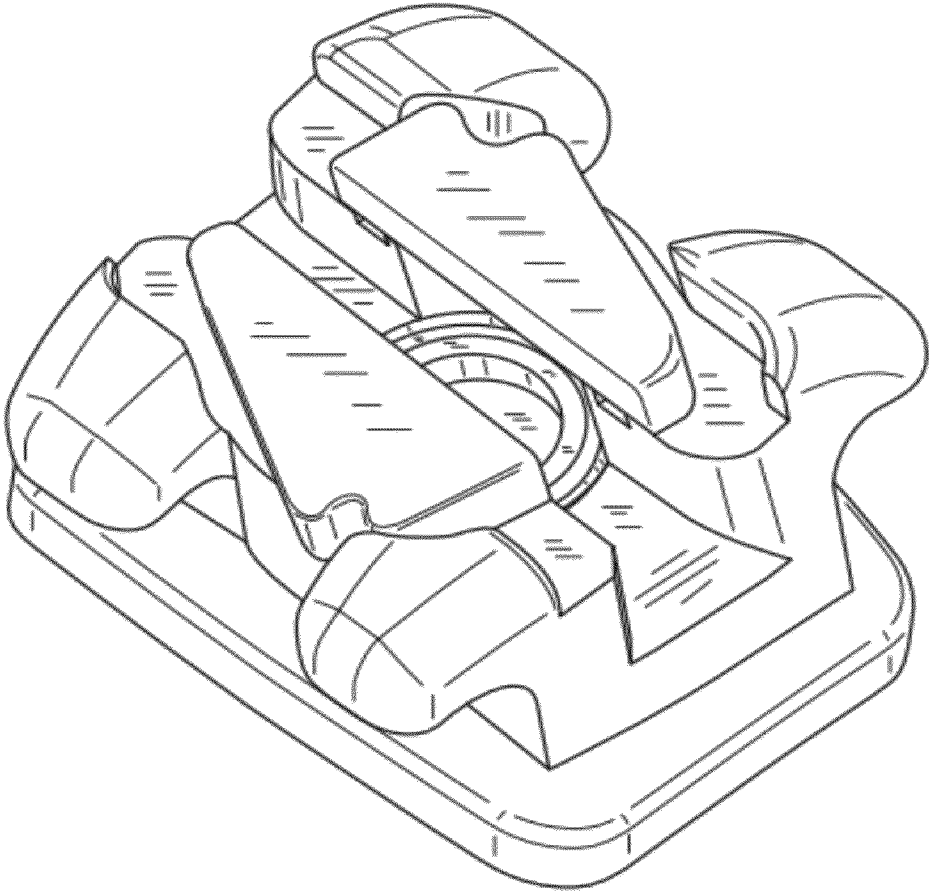

FIG.1

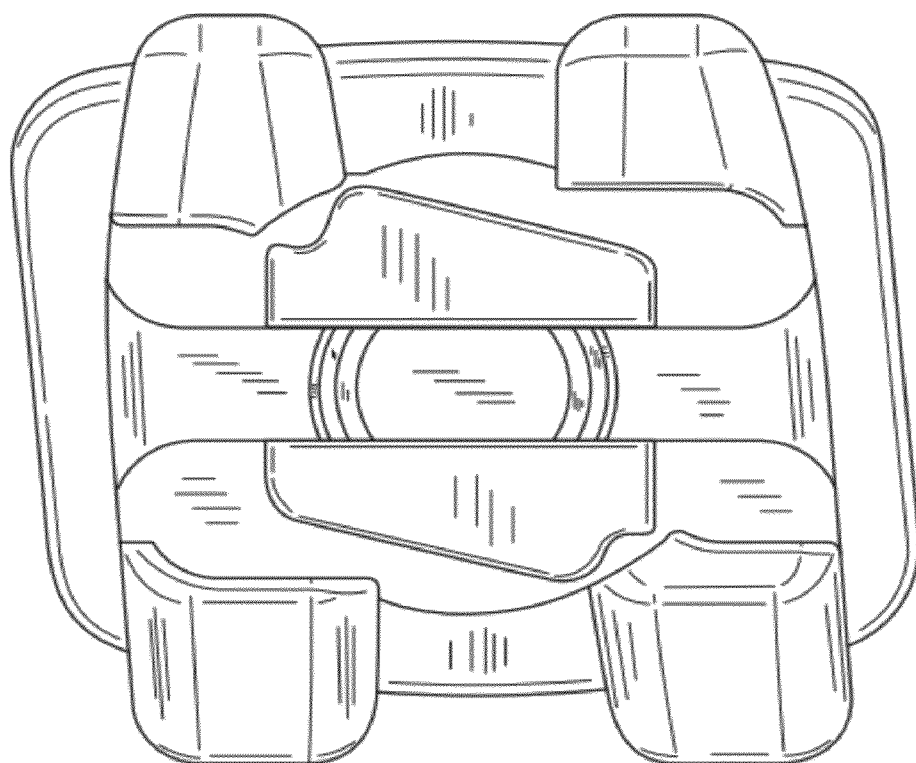

FIG.2

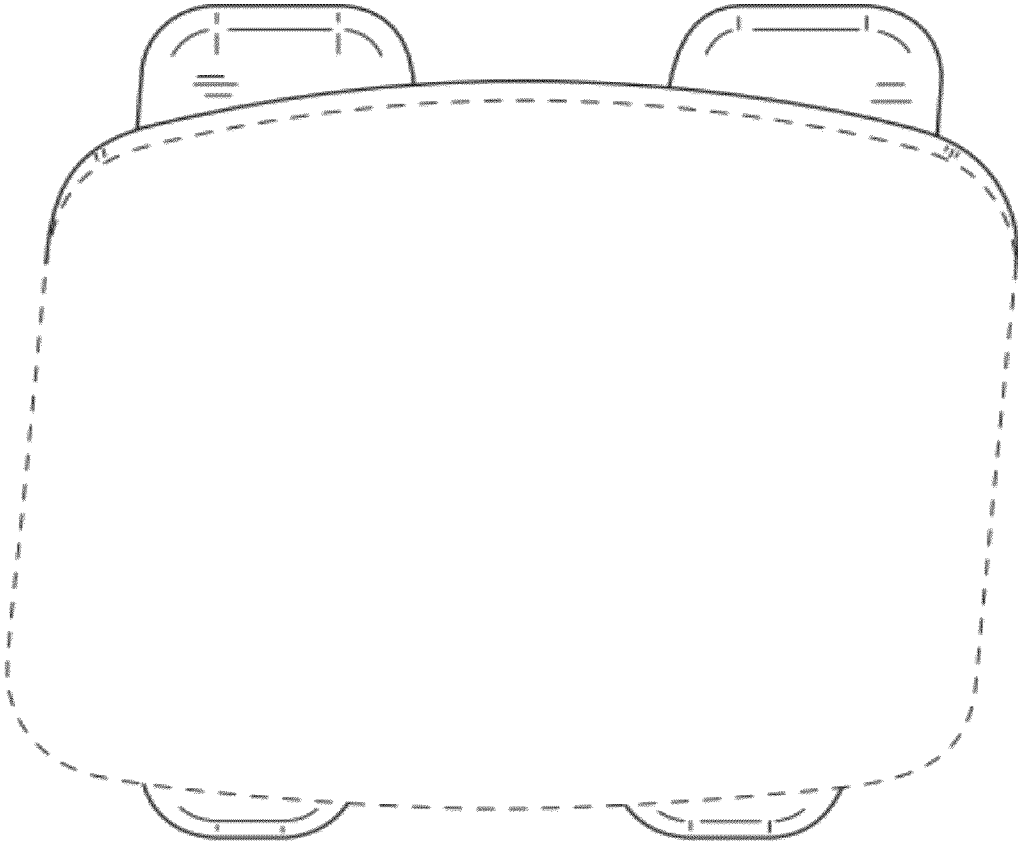

FIG.3

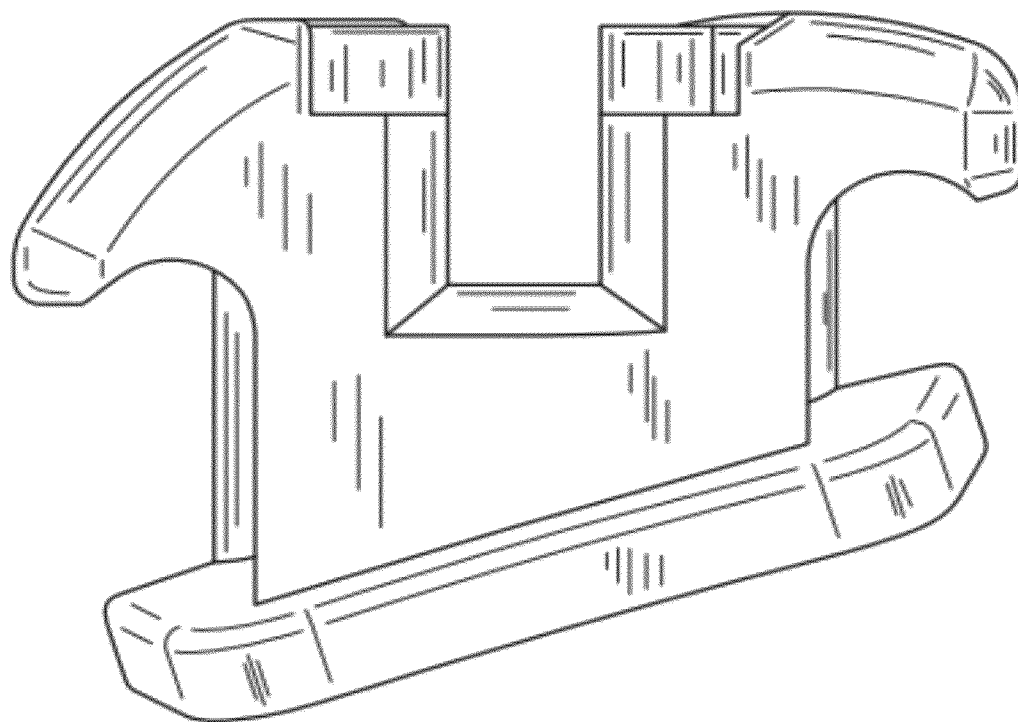

FIG.4

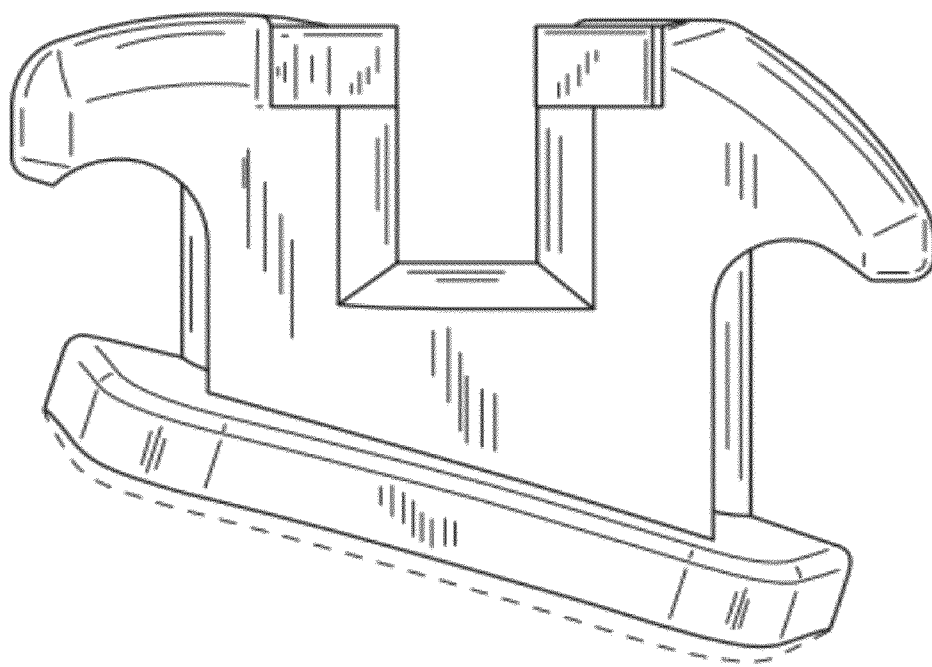

FIG.5

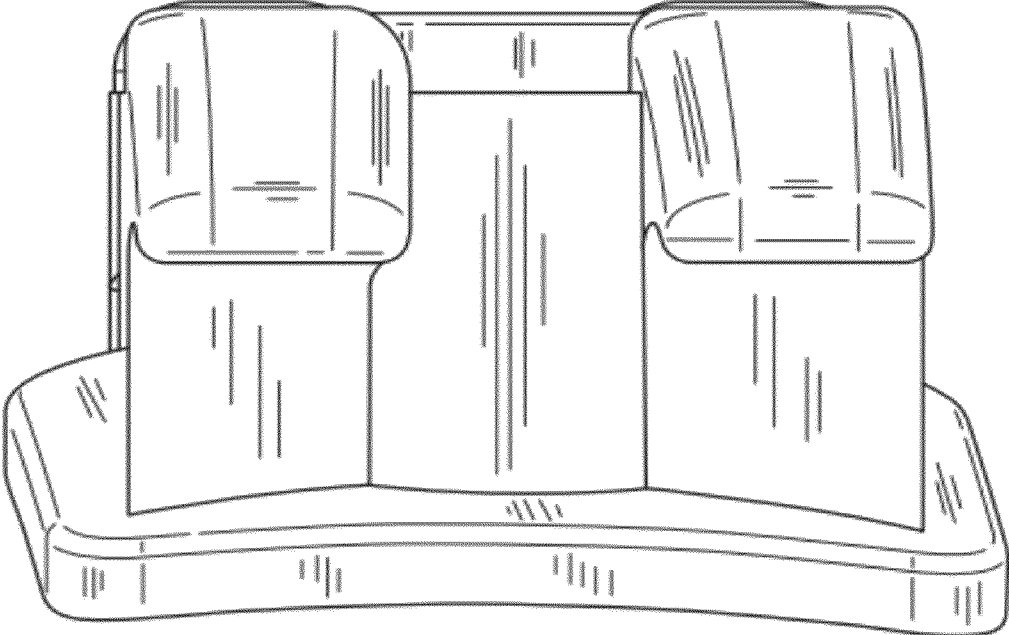

FIG.6

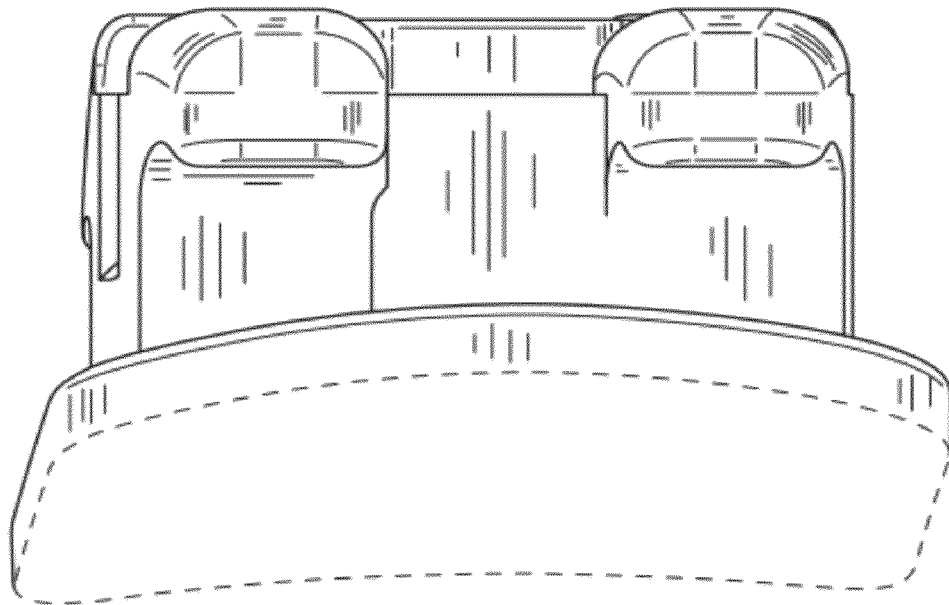

FIG.7

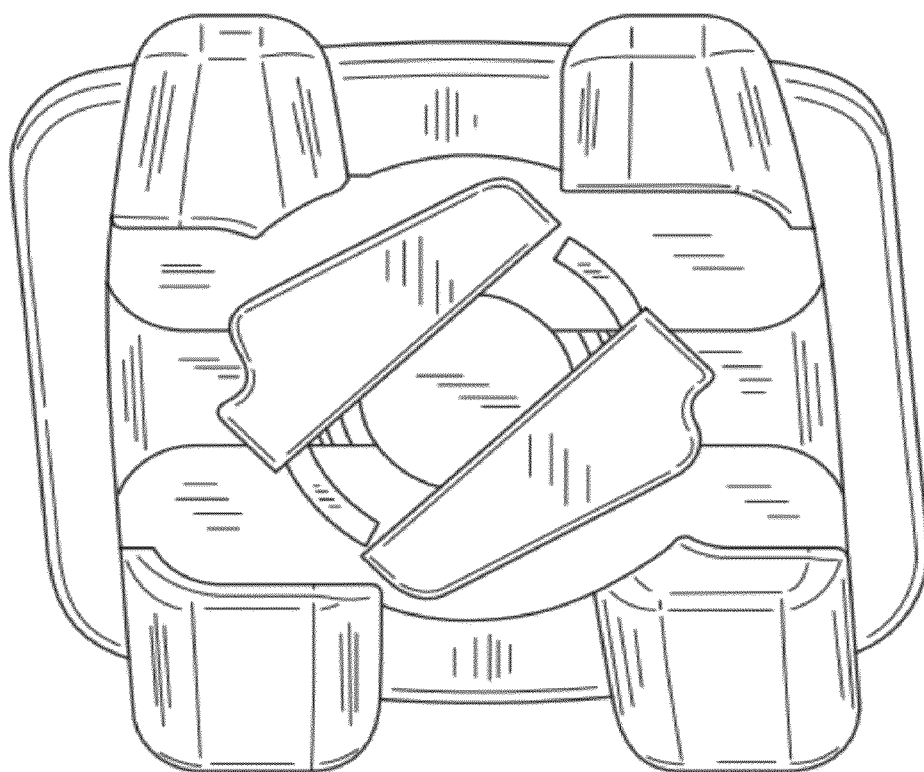

FIG.8

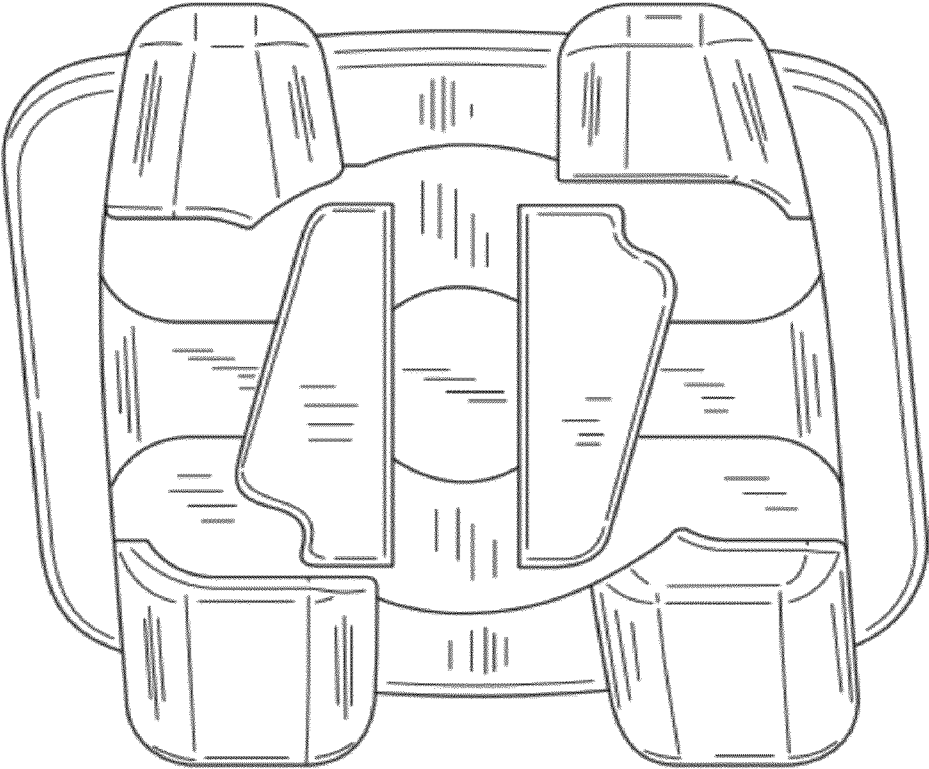

FIG.9