



(51) International Patent Classification:

A61M 1/10 (2006.01) A61M 1/12 (2006.01)

(21) International Application Number:

PCT/EP2018/066590

(22) International Filing Date:

21 June 2018 (21.06.2018)

(25) Filing Language:

English

(26) Publication Language:

English

(30) Priority Data:

17177180.1 21 June 2017 (21.06.2017) EP  
17184552.2 02 August 2017 (02.08.2017) EP

(71) Applicant: **ABIOMED EUROPE GMBH** [DE/DE];  
Neuenhofer Weg 3, 52074 Aachen (DE).

(72) Inventors: **ABOULHOSN, Walid**; c/o Abiomed Europe  
GmbH, Neuenhofer Weg 3, 52074 Aachen (DE). **SIESS,  
Thorsten**; c/o Abiomed Europe GmbH, Neuenhofer Weg 3,  
52074 Aachen (DE). **KIRCHHOFF, Frank**; c/o Abiomed  
Europe GmbH, Neuenhofer Weg 3, 52074 Aachen (DE).

(74) Agent: **KLUNKER IP PATENTANWÄLTE PARTG  
MBB**; Destouchesstraße 68, 80796 München (DE).

(81) Designated States (*unless otherwise indicated, for every  
kind of national protection available*): AE, AG, AL, AM,  
AO, AT, AU, AZ, BA, BB, BG, BH, BN, BR, BW, BY, BZ,  
CA, CH, CL, CN, CO, CR, CU, CZ, DE, DJ, DK, DM, DO,  
DZ, EC, EE, EG, ES, FI, GB, GD, GE, GH, GM, GT, HN,  
HR, HU, ID, IL, IN, IR, IS, JO, JP, KE, KG, KH, KN, KP,  
KR, KW, KZ, LA, LC, LK, LR, LS, LU, LY, MA, MD, ME,  
MG, MK, MN, MW, MX, MY, MZ, NA, NG, NI, NO, NZ,  
OM, PA, PE, PG, PH, PL, PT, QA, RO, RS, RU, RW, SA,

SC, SD, SE, SG, SK, SL, SM, ST, SV, SY, TH, TJ, TM, TN,  
TR, TT, TZ, UA, UG, US, UZ, VC, VN, ZA, ZM, ZW.

(84) Designated States (*unless otherwise indicated, for every  
kind of regional protection available*): ARIPO (BW, GH,  
GM, KE, LR, LS, MW, MZ, NA, RW, SD, SL, ST, SZ, TZ,  
UG, ZM, ZW), Eurasian (AM, AZ, BY, KG, KZ, RU, TJ,  
TM), European (AL, AT, BE, BG, CH, CY, CZ, DE, DK,  
EE, ES, FI, FR, GB, GR, HR, HU, IE, IS, IT, LT, LU, LV,  
MC, MK, MT, NL, NO, PL, PT, RO, RS, SE, SI, SK, SM,  
TR), OAPI (BF, BJ, CF, CG, CI, CM, GA, GN, GQ, GW,  
KM, ML, MR, NE, SN, TD, TG).

Declarations under Rule 4.17:

- as to applicant's entitlement to apply for and be granted a  
patent (Rule 4.17(ii))
- of inventorship (Rule 4.17(iv))

Published:

- with international search report (Art. 21(3))

(54) Title: CANNULA FOR INTRAVASCULAR BLOOD PUMP

FIG 3a

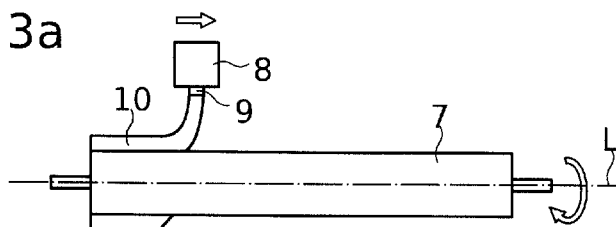

(57) Abstract: A method of manufacturing a cannula (4) for an intravascular blood pump comprises the steps of forming a first axial section (13) and a second axial section (15) of an elongate tubular body of the cannula (4) by dispensing a first liquid material and a second liquid material, respectively, onto a mandrel (7) by means of at least one dispenser (8). The mandrel (7) is rotated and the dispenser (8) moves relative to the mandrel (7) in an axial direction during dispensing of the liquid materials. The first and second axial sections (13,15) are formed so as to have different bending stiffnesses. The first and second liquid materials are dispensed onto the mandrel (7) such that the first and second liquid materials blend into each other to form a smooth transition area (14).



## CANNULA FOR INTRAVASCULAR BLOOD PUMP

## BACKGROUND

[0001] This invention relates to a method of manufacturing a cannula for an intravascular blood pump for percutaneous insertion into a patient's blood vessel, as well as a cannula obtainable by said method.

[0002] Intravascular blood pumps are used to support the function of a patient's heart, either as a left ventricular assist device (LVAD) or right ventricular assist device (RVAD). An intravascular blood pump for percutaneous insertion typically comprises a catheter and a pumping device and is inserted into the patient's heart, e.g. through the aorta into the left ventricle. The pumping device comprises a blood flow inlet and a blood flow outlet and a cannula through which the blood flow is created e.g. by a rotor of the pumping device. For example, the cannula may extend through the aortic valve with the blood flow inlet disposed at a distal end of the cannula in the left ventricle and the blood flow outlet disposed at a proximal end of the cannula in the aorta.

[0003] The cannula may be relatively soft and flexible, e.g. made of silicone, soft polyurethane or polyester (Dacron®) to reduce the risk of causing damage to a cardiac valve. However, if a very soft cannula is connected to the housing of the pumping device, which is e.g. made of metal, the cannula's material at the interface between the housing of the pumping device and the cannula may crack because the interface is subject to high loads. There is also a high risk that thrombi form in the cracks of the material, which may cause harm to the patient if they separate from the blood pump and are transported through the vascular system. A stiffer cannula may be made e.g. from hard polyurethane. However, if the cannula is too stiff, side movements of the cannula in the cardiac valve may cause harm to the valve's leafs. It is also known to increase the strength of a soft cannula by incorporating a helical wire, e.g. a Nitinol wire. However, this may lead to a scissor-like effect at the interface between the housing of the pumping device and the cannula and may, thus, damage the material of the cannula. Thus, in view of the aforementioned, the cannula should be soft enough to avoid damage to the cardiac valve but should provide sufficient stiffness to avoid damage of the material.

## SUMMARY OF THE INVENTION

[0004] It is an object of the present invention to provide an improved method of manufacturing a cannula for an intravascular blood pump that has a stiffness to withstand loads during operation of the blood pump while not causing harm to the patient's body.

[0005] This object is achieved according to the present invention by a method of manufacturing a cannula for an intravascular blood pump and a cannula obtained by such method having the features of the independent claims. Preferred embodiments and further developments of the invention are specified in the claims dependent thereon. Throughout this disclosure, the term "distal" refers to directions away from a user and towards the heart, whereas the term "proximal" refers to directions towards a user.

[0006] Broadly speaking, according to the invention, a cannula for an intravascular blood pump is manufactured by dispensing liquid material onto an elongate element, such as a mandrel. Preferably, the liquid material is applied in layers which dry or cure to form different axial sections of an elongate tubular body of the cannula. The mandrel is removed after the body is completed. This method allows adjusting the characteristics of the cannula, such as bending stiffness, along the length of the cannula. Rather than attaching different axial sections to one another, e.g. by welding, bonding, adhesive or the like, the axial sections of the cannula of the present invention are produced by dispensing liquid material onto a mandrel such that no distinct borders can be determined between the axial sections but blend smoothly into one another. Thus, material borders can be avoided at which high stresses could occur during operation of the blood pump.

[0007] More specifically, according to one embodiment, the method comprises the step of forming a first axial section of the cannula's body by dispensing a first liquid material onto a mandrel by means of at least one dispenser, while the mandrel and the dispenser move relative to each other in an axial direction and a circumferential direction of the mandrel. The method further comprises the step of forming a second

axial section by dispensing a second liquid material onto the mandrel by means of the at least one dispenser, while the mandrel and the dispenser move relative to each other in an axial direction and a circumferential direction of the mandrel.

[0008] The first and second liquid materials are dispensed onto the mandrel such that the first and second liquid materials blend into each other to form a transition area. For instance, the transition area may extend over an axial length of at least 10  $\mu\text{m}$  to provide a smooth transition between the first and second axial sections. The first and second axial sections are formed so as to have different bending stiffnesses. The first and second materials may be dispensed by a single dispenser or different dispensers. In case only one dispenser is used, the first and second materials may be dispensed by a single nozzle or different nozzles of the dispenser.

[0009] As mentioned above it will be appreciated that the method preferably further comprises the step of curing or drying the dispensed layers of liquid material to form the final product. In particular, the materials may be at least partially dried or cured before the next layer of a liquid material is dispensed. A liquid material may be a material comprising a solvent as described hereinafter in more detail, a molten material, an extruded material or the like having a viscosity which is suitable to allow dispensing the material onto the rotating mandrel. In particular, the one or more materials of the cannula may be a polymer material or polymer materials.

[0010] In other words, a cannula that can be obtained by the aforementioned method has an elongate tubular body with a blood flow inlet and a blood flow outlet, wherein the body comprises a first axial section comprising a first material and a second axial section comprising a second material, wherein the first and second axial sections have different bending stiffnesses, and wherein the first and second materials blend into each other in a transition area. The cannula may have more than two axial sections with different bending stiffnesses. For example, one or more flexing portions having a low bending stiffness can be created that connect stiffer axial sections with a greater bending stiffness. The lengths of the axial sections can be chosen as desired, e.g. depending on the application. For example, the flexing portions can be shorter or longer than the stiffer portions.

[0011] In one embodiment, the first and second liquid materials are dispensed onto the mandrel to form a first wall thickness of the first axial section and a second wall thickness of the second axial section, respectively, wherein the first wall thickness is different from the second wall thickness. Alternatively or in addition, the first and second liquid materials may be different. The different bending stiffnesses may result from at least one of the differing wall thicknesses and the differing materials. Throughout this disclosure, the term “wall thickness” and respective values given for the wall thickness refer to the final state of the cannula, i.e. in particular after curing or drying of the materials, unless otherwise indicated.

10 [0012] In case the first and second materials are different, they may axially overlap in the transition area. Suitable materials are soft polyurethane, hard polyurethane, polyethylene, silicone or the like. It will be appreciated that the first and second materials may be identical. Instead of overlapping, the materials may blend into each other, independently of whether they are identical or different. The wall thicknesses may be influenced by a variety of parameters, such as material, dispensed amount of material, dispensing rate, speed of movement of one or both of the mandrel and the dispenser, and proportion of solvent in the materials etc. as will be described in more detail below. Thus, the characteristics, in particular the bending stiffnesses, of the first and second axial section can be adjusted as desired.

20 [0013] The first axial section may be a proximalmost section or a distalmost section of the cannula's body and may have a greater bending stiffness than the second axial section or the rest of the cannula's body. In particular, the section connecting to a housing of a pumping device may have a greater bending stiffness than the rest of the cannula's body. This provides sufficient strength at the interface between the cannula and the housing of the pumping device, and at the same time provides soft characteristics of the cannula to avoid damages to surrounding tissue, such as a cardiac valve.

[0014] As mentioned above, the mandrel and the dispenser move relative to each other in an axial direction and a circumferential direction of the mandrel during dispensing of the liquid materials onto the mandrel. This may be achieved by rotating

30

the mandrel about its longitudinal axis, e.g. on a lathe, and moving the dispenser in an axial direction along the mandrel while dispensing the first and second liquid materials. The mandrel is preferably rotated at a speed of about 10 to 15 rpm (revolutions per minute), more preferably at about 12 rpm. It will be appreciated that the dispenser may  
5 be alternatively fixed in an axial direction and the rotating mandrel may be moved in an axial direction. It may also be possible to move the dispenser in a circumferential direction about the mandrel, e.g. if the liquid materials are sprayed onto the mandrel. A person skilled in the art will understand that any combination of axial and circumferential or rotational movement of the mandrel and the dispenser, respectively,  
10 may be suitable to achieve the desired relative movement between the mandrel and the dispenser. Preferably, the mandrel has a circular cross-section, but other cross-sectional shapes are possible. The mandrel may have a length of about 1 cm to 40 cm, which will result in a cannula having a length of about 1 cm to 40 cm. The mandrel may have a diameter of about 1 mm to 10 mm, which will result in a cannula having an inner  
15 diameter of about 1 mm to 10 mm.

**[0015]** The method may further comprise the step of forming a base layer that extends along the entire length of the cannula's body by dispensing a third liquid material onto the mandrel. The base layer is preferably formed by dispensing a substantially uniform amount of the third liquid material with respect to the length of  
20 the mandrel, wherein the base layer preferably has a thickness of about 50  $\mu\text{m}$  to 100  $\mu\text{m}$ . The third material may be different from the first and second materials or may be identical to at least one of the first and second materials. The base layer may be provided to create a uniform support for the tubular body of the cannula, while the characteristics of the first and second axial sections are adjusted by subsequent layers of  
25 the first and second materials that are applied onto the base layer. Other specific layers or axial sections with specific properties can be included in the cannula. For example, an area for enhanced metal adhesion can be created by providing a primer layer. One or more layers may be provided with a medical agent, such as heparin, to avoid clot formation on the surface of the cannula's body.

30 **[0016]** The method may further comprise the step of forming a stiffening structure by dispensing a fourth liquid material on the mandrel, preferably a polymer

material, wherein the first and second liquid materials are preferably dispensed both before and after dispensing the fourth material so as to embed the stiffening structure in the cannula's body. The stiffening structure may be formed along a helical path or any other suitable structure, such as longitudinal or circumferential struts or a grid structure.

5 The fourth material has preferably a higher Young's modulus (elastic modulus) than the first and second materials in order to provide sufficient strength to form a stiffening structure. For example, the fourth material of the stiffening structure may be hard polyurethane, while the first and second materials may be soft polyurethane, polyethylene or silicone. That means the elongate tubular body of the cannula may  
10 comprise an embedded stiffening structure made of a plastic material rather than embedding a stiffening structure made of a metal. Alternatively or in addition, the cannula's body may comprise a stiffening structure that comprises a thread or wire, which may be made of metal, preferably a shape memory material, such as Nitinol, or may be made of a polymer. The wire may extend in a helical shape about the cannula. If  
15 it is made of a metal it may be pre-wound before it is added to the cannula. Alternatively, the thread or wire, e.g. if made of a polymer, may be wound around the mandrel along a helical path or other suitable pattern, e.g. two opposite helical paths crossing each other, or other braid pattern. For instance, the helical wire may be embedded into the cannula's body between layers of the first and second materials.

20 **[0017]** Advantageously, at least one of the first and second liquid materials comprises a solvent that evaporates after dispensing the first and second liquid materials, respectively, wherein the proportion of the solvent is at least 70 %, preferably at least 80 %, more preferably at least 90 %. The proportion of the solvent is preferably measured in percent by volume (vol%), but may alternatively be measured in percent by  
25 weight if appropriate. The solvent preferably evaporates but may alternatively or in addition be absorbed by the mandrel, which may be provided with a porous structure for this purpose. The first and second materials may comprise the same proportion of solvent or a different proportion of solvent that blend into each in the transition area. If the proportion of solvent is different, this will result in different wall thicknesses or the  
30 respective sections after the solvent has evaporated, i.e. after drying.

[0018] The provision of a solvent in the liquid materials facilitates manufacture of very thin layers because the major part of the applied material evaporates after dispensing on the mandrel. That means that the layers of liquid material “physically dry” on the mandrel before another layer of liquid material is dispensed. However, the layers should not completely dry and cure before a subsequent layer is dispensed in order to ensure that the subsequent layers sufficiently blend to form an integral elongate tubular body. Preferably, at least one of the first and second axial sections is formed by dispensing at least 5, preferably at least 10, up to 20 layers of the first and second liquid materials, respectively. This may result in a cannula having an elongate tubular body with a wall thickness in the range from about 50  $\mu\text{m}$  to about 500  $\mu\text{m}$ , after drying and curing of the materials. Generally, any number of layers, different materials, axial sections etc. may be produced as desired. Additional layers may be created by at least partially dipping the cannula manufactured by the described dispensing method into a liquid material.

[0019] In one embodiment, the mandrel may have a circumferential shoulder interconnecting two axially adjacent parts of the mandrel with different diameters, wherein the two axially adjacent parts of the mandrel are preferably separated from each other to remove the cannula from the mandrel. Thus, the elongate tubular body of the cannula may have a circumferential shoulder interconnecting two axially adjacent sections of the body with different diameters.

[0020] The method may further comprise the step of forming at least one marking arranged on the cannula’s body, wherein the at least one marking may be visually perceptible, e.g. by exhibiting a different color than the cannula’s body, or may be radiopaque so as to be visible under x-ray. Preferably, the at least one marking is formed by dispensing a liquid material by means of the dispenser. The at least one marking may extend on or may be embedded in the elongate tubular body. For example, the marking may be a colored band that extends about the cannula’s body.

[0021] The method may further comprise the step of forming a lumen extending in the wall of the cannula’s body by embedding an elongate element in the wall of the cannula’s body. The elongate element may be a hollow tubular element that remains in



the cannula's body to form the lumen. Alternatively, the elongate element may be a solid filament that is removed from the cannula's body to form the lumen.

[0022] The method may further comprise the step of forming at least one aperture in the cannula's body by dispensing a liquid material onto the mandrel, optionally without rotating the mandrel or with rotating the mandrel very slowly, while dispensing said liquid material. In particular, a cage structure at one end of the cannula can be formed by dispensing material onto the mandrel, which is similar to a 3D printing process. A viscosity of the material is chosen so as to prevent dropping of the material but allowing merging with other printed areas or earlier or later dispensed layers of the cannula's body. Thus, a structure that is printed in this manner will attach to the body of the cannula and form an integral part of the cannula.

[0023] The method may further comprise the step of attaching the cannula to a housing of a pumping device of an intravascular blood pump, i.e. the invention also relates to an intravascular blood pump for percutaneous insertion into a patient's blood vessel, comprising a cannula obtained by the above-described method.

#### BRIEF DESCRIPTION OF THE DRAWINGS

[0024] The foregoing summary, as well as the following detailed description of preferred embodiments, will be better understood when read in conjunction with the appended drawings. For the purpose of illustrating the present disclosure, reference is made to the drawings. The scope of the disclosure is not limited, however, to the specific embodiments disclosed in the drawings. In the drawings:

Fig. 1 shows a patient's heart with an intravascular blood pump inserted through the aorta into the left ventricle.

Fig. 2 shows an enlarged view of the interface between the cannula and the housing of the pumping device of an intravascular blood pump.

Figs. 3a to 3d show steps of a method of manufacturing the cannula.

Figs. 4a to 4d show steps of a method of manufacturing the cannula according to another embodiment.

Figs. 5a to 5d show steps of a method of manufacturing the cannula according to still another embodiment.

5 Fig. 6 shows a layer of the cannula before and after evaporation of a solvent.

Fig. 7 shows a cannula with a stiffening structure.

Fig. 8 shows a cannula with a marking.

Fig. 9 shows a cannula on a mandrel having a circumferential shoulder.

Fig. 10 shows a detail of the cannula during manufacture of a lumen in the cannula.

10 Fig. 11 shows a perspective view of a 3D printing process of an inflow cage of the cannula.

#### DETAILED DESCRIPTION

[0025] In Fig. 1 is illustrated a blood pump inserted into a patient's heart H.  
15 More specifically, the blood pump comprises a pumping device 1 attached to a catheter 10 by means of which the pumping device 1 is inserted into the left ventricle LV of the patient's heart H via the aorta AO, including the descending aorta DA and the aortic arch AA. The catheter 10 has a distal end 10a and a proximal end 10b. The pumping device 1 has a blood flow outlet 3 that is disposed outside the patient's heart H in the  
20 aorta AO, while a blood flow inlet 2 is in flow communication with a cannula 4 placed inside the left ventricle LV. An impeller (not shown) is provided in a housing 1a of the pumping device 1 to cause the blood flow from the blood flow inlet 2 to the blood flow outlet 3. At the distal end of the blood pump, a soft tip 5, such as a pigtail or J-tip, is arranged to facilitate insertion of the blood pump into the patient's heart H without  
25 causing any harm to the surrounding tissue. Also, the soft tip 5 helps to keep soft tissue away from the cannula 4.

[0026] Fig. 2 shows an enlarged schematic cross-sectional view of the interface 6 between the housing 1a of the pumping device 1 and the cannula 4. The housing 1a and the cannula 4 are stepped at their respective ends 22, 23 which are to be attached to one another. While the housing 1a of the pumping device 1 may be made of metal, the  
5 cannula 4 may be made of a plastic material, such as silicone, polyethylene or polyurethane. At the interface 6 between the relatively hard material of the housing 1a of the pumping device 1 and the relatively soft material of the cannula 4 the loads during operation of the blood pump may cause cracks in the material of the cannula 4. Therefore, it is desirable to increase the bending stiffness of the cannula 4 in the region  
10 of the interface 6. However, the rest of the cannula 4 should be softer to avoid damages to the surrounding tissue, such as the leafs of a cardiac valve.

[0027] A method of manufacturing a cannula 4 that can exhibit different characteristics along its length, in particular different bending stiffnesses, is shown schematically in Figs. 3a to 3d. The core idea of the method is that the cannula is  
15 produced by dispensing liquid material onto an elongate element, such as a mandrel, rather than attaching different sections to one another. The following steps are shown schematically and not true to scale for illustrative purposes. In particular, for the sake of simplicity, the steps are shown only for a single layer in each axial section. It will be appreciated, however, that more than one, up to 20 layers or more, may be applied in  
20 each axial section.

[0028] In a first step, shown in Fig. 3a, a base layer 10 is applied onto a mandrel 7. In order to create the base layer 10, a liquid material is applied onto the mandrel 7 by means of a dispenser 8 having at least one nozzle 9 to dispense the liquid material. During dispensing the liquid material, the mandrel 7 is rotated about its longitudinal  
25 axis L, which is coincident with the longitudinal axis L of the cannula 4. The mandrel 7 may be rotated by means of a suitable apparatus, such as a lathe (not shown). The speed of rotation may be about 12 rpm. The dispenser 8 is moved in an axial direction along the length of the mandrel 7. The axial speed of the dispenser 8 and the rotational speed of the mandrel 7 are chosen such that a continuous layer of liquid material can be  
30 applied along the length and about the circumference of the mandrel 7. The final base layer 10, i.e. after drying and curing, may have a thickness of about 50  $\mu\text{m}$  to 100  $\mu\text{m}$ .

[0029] After the base layer 10 is fully applied onto the mandrel 7 and at least dried to a desired degree, as will be explained in more detail below with respect to Fig. 5, a layer 11 of a liquid material is applied in the same manner as the base layer 10, i.e. by moving the dispenser 8 along the longitudinal direction of the mandrel 7, while the mandrel 7 is rotated, as shown in Fig 3b. The liquid material of the layer 11 may be the same material as the material of the base layer 10 or a different material. The same dispenser 8 may be used. In particular, if the material is different, it may be dispensed by another nozzle of the dispenser 8 or possibly another dispenser. The layer 11 is part of a first axial section 13 of the cannula 4 (see Fig. 3d) and is applied only along a part of the length of the mandrel 7.

[0030] As shown in Fig. 3c, a layer 12 of another liquid material is applied axially adjacent the layer 11 onto the mandrel 7 in the same manner as described above, i.e. by moving the dispenser 8 along the longitudinal direction of the mandrel 7, while the mandrel 7 is rotated. The material of the layer 12 may be different from the material of the layer 11. As indicated in Fig. 3c, the layer 12 is thicker than the layer 11. The layer 12 is part of a second axial section 15 of the cannula 4 (see Fig. 3d) and is applied only along a part of the length of the mandrel 7. The layers 11 and 12 overlap and blend into each other to form a smooth transition area 14 between the first and second axial sections 13, 15 that extends over a length of at least 10  $\mu\text{m}$ .

[0031] By appropriately choosing materials and wall thicknesses of the layers 11 and 12, the bending stiffnesses of the first and second axial sections 13 and 15 can be adjusted as desired. It will be appreciated that the first and second axial sections 13, 15 each preferably comprise more than one layer of material. In other words, more than one layer 11 and more than one layer 12 are applied onto the mandrel 7 to form the first axial section 13 and the second axial section 15, respectively. Apart from that, more than two axial sections connected by respective transition areas can be created on the mandrel 7. For example, sections of low bending stiffness may be created so as to alternate with sections of high bending stiffness in order to create a cannula having stiff portions connected by flexing portions. After the desired amount of material has been applied onto the mandrel 7 and sufficiently cured, the mandrel 7 is removed from the cannula 4 as indicated in Fig. 3d.

[0032] Figs. 4a to 4d show substantially the same method as Figs. 3a to 3d. The only difference is that the material of the layer 12 is the same material as the material of the layer 11. The different bending stiffnesses of the first axial section 13 and the second axial section 15 result from different wall thicknesses. Figs. 5a to 5d show substantially the same method as Figs. 3a to 3d. In this embodiment, the materials of the layers 11 and 12 are different but the wall thickness is constant along the length of the cannula 4, i.e. the wall thicknesses of the first axial section 13 and the second axial section 15 are the same. The different bending stiffnesses result from the different materials. As shown particularly in Fig. 5d, the different materials of the first and second axial sections 13, 15 blend into each other in the transition area 14. Alternatively, also referring to Figs. 5a to 5d, the materials of the layers 11 and 12 may be the same but may comprise a different proportion of solvent and blend into each other in the transition area. For instance, the layer 11 may comprise less solvent than the layer 12, which would result in different wall thicknesses of the layers 11 and 12 (i.e. the first and second axial sections, 13, 15) after curing (not shown).

[0033] Referring now to Fig. 6, and as already mentioned briefly above, the liquid materials preferably comprise a solvent. The proportion of the solvent in each material may be more than 80 vol%, preferably more than 90 vol%. The principle is exemplarily shown with respect to the layer 11 in Fig. 6. Fig. 6 shows the layer 11 applied on the mandrel 7 before evaporation of the solvent (left) and after evaporation of the solvent (right). After evaporation of the solvent, which can be denoted as “physically drying”, the thickness of the applied is reduced approximately by the amount of the solvent. Using a high proportion of a solvent facilitates manufacture of very thin layers as most of the applied material will evaporate. In other words, a relatively large amount of material can be dispensed, while only a small amount of material will be present in the completed cannula 4. This is easier than applying a small amount without a solvent to create a thin layer and requires less accuracy for the dispenser.

[0034] Figs. 7 to 11 show different aspects that may be included in a cannula 4 either alone or in any combination. For the sake of simplicity, the cannula 4 is shown as

an integral piece in Figs. 7 to 11. However, the cannula 4 comprises different layers and axial sections as described above.

[0035] The cannula 4 shown in Fig. 7 comprises a stiffening structure 16 embedded in a wall of the cannula 4. The stiffening structure 16 may have a helical shape extending about the cannula 4 or may form any other suitable pattern that strengthens the cannula 4. The stiffening structure 16 may be created by dispensing a liquid material by means of the dispenser 8. However, rather than creating a continuous layer as described above, the liquid material for the stiffening structure 16 is applied along a helical path on the mandrel 7. This material is applied onto previously created layers and covered by subsequent layers such that the stiffening structure 16 is embedded in the wall of the cannula 4. For instance, the stiffening structure 16 may be made of polyurethane, while the surrounding material is polyethylene, which is softer than polyurethane. In particular, the stiffening structure 16 has a higher elastic modulus than the rest of the wall of the cannula 4.

[0036] Alternatively or in addition, the cannula may comprise a stiffening structure formed of a helical Nitinol wire, which is pre-wound and incorporated in the cannula 4 during the dispensing process to be embedded in the wall of the cannula 4. Further alternatively, a polymer thread may be wound about the mandrel between material layers of the cannula. As mentioned above, any above-described stiffening structure is advantageously embedded between layers of the cannula 4. For instance, a first layer of material may be applied followed by the stiffening structure (e.g. liquid material along a path, pre-wound Nitinol wire or polymer thread), which is subsequently covered by one or more further layers of material. This is exemplarily indicated by layers 10 and 11 in Fig. 7. It will be appreciated that the cannula 4 may comprise more layers than the layers 10 and 11 in Fig. 7.

[0037] Referring now to Fig. 8, a cannula 4 is shown having a marking 17 that is visible by the human eye, e.g. by exhibiting a different color than the surrounding material, or that is visible under x-ray, i.e. radiopaque. The marking 17 may be applied on the cannula 4 or embedded in the cannula 4. The marking may extend along a helical path or along any other desired path. It can be manufactured by dispensing a liquid

material as described above with respect to the stiffening structure 16. Also, the wire or thread as described above may carry the marking. For instance, the wire or thread may be radiopaque.

5 [0038] Fig. 9 shows a cannula 4 having a circumferential shoulder 18, i.e. the cannula 4 has sections 25, 26 that differ in their respective inner and outer diameters. Accordingly, the mandrel 7 has a respective circumferential shoulder 24 interconnecting two mandrel parts 7a, 7b with different diameters. In order to facilitate removal of the mandrel 7 from the finished cannula 4, the parts 7a, 7b are separable.

10 [0039] The cannula 4 shown in Fig. 10 has a lumen 19 extending through the wall of the cannula 4. The lumen 19 can be created by incorporating a filament 20 during the above-described dispensing method. If the filament 20 is solid, it will be pulled out of the cannula 4 after the production of the cannula 4 is finished to form the lumen 19. Alternatively, a hollow filament may be used that is embedded in the cannula 4 to form the lumen 19.

15 [0040] The method of manufacturing the cannula 4 may further comprise the step of creating at least one opening in the cannula 4, e.g. the aforementioned blood flow inlet 2, as shown in Fig. 11. A cage structure 21 or the like can be created by means of the dispenser 8 to form the openings 2. For this purpose, the mandrel 7 is preferably not rotated or rotated very slowly, depending on the desired shape of the cage structure 21. For instance, the mandrel 7 should not be rotated if longitudinal struts are created. The viscosity of the dispensed material of the cage structure 21 is chosen such that the material will not drop from the mandrel 7 but will blend with the previously or subsequently applied layers of the cannula 4 to form an integral body.

25 [0041] The method of manufacturing a cannula including the dispensing steps as described above allows manufacture of a cannula with adjustable characteristics along the length of the cannula, including any desired structure. The aforementioned features can be included alone or in combination into a cannula. The wall thickness may be influenced by a variety of parameters, such as type of material, dispensed amount of material, dispensing rate, speed of movement of one or both of the mandrel and the dispenser, and proportion of solvent in the materials etc. It will be appreciated that any  
30

desired number, order and arrangement of layers can be included in the cannula. Any number, order and arrangement of axial sections with different characteristics, such as bending stiffness, can be created as desired. The described embodiments are for illustrative purposes and not intended to be limiting. The invention is defined in the  
5 appended claims.



## CLAIMS

1. A method of manufacturing a cannula (4) for an intravascular blood pump for percutaneous insertion into a patient's blood vessel, the cannula (4) having an elongate tubular body with a blood flow inlet and a blood flow outlet, the method comprising the steps of:
- 5
- forming a first axial section (13) of the elongate tubular body by dispensing a first liquid material onto a mandrel (7) by means of at least one dispenser (8), while the mandrel (7) and the dispenser (8) move relative to each other in an axial direction and a circumferential direction of the mandrel (7),
  - 10 - forming a second axial section (15) of the elongate tubular body by dispensing a second liquid material onto the mandrel (7) by means of the at least one dispenser (8), while the mandrel (7) and the dispenser (8) move relative to each other in an axial direction and a circumferential direction of the mandrel (7),
- 15 wherein the first and second axial sections (13, 15) are formed so as to have different bending stiffnesses, and wherein the first and second liquid materials are dispensed onto the mandrel (7) such that the first and second liquid materials blend into each other to form a transition area (14).
2. The method of item 1, wherein the first and second liquid materials are dispensed onto the mandrel (7) to form a first wall thickness of the first axial section (13) and a second wall thickness of the second axial section (15), respectively, wherein the first wall thickness, when dried, is different from the second wall thickness, when dried, and the different bending stiffnesses result from the different wall thicknesses.
- 20
3. The method of item 1 or 2, wherein the first and second liquid materials are different and the different bending stiffnesses result from the different materials.
- 25
4. The method of any one of items 1 to 3, wherein the mandrel (7) is rotated about its longitudinal axis, preferably at a speed of about 10 to 15 rpm, preferably about 12 rpm.

5. The method of any one of items 1 to 4, wherein the dispenser (8) is moved in an axial direction along the mandrel (7) while dispensing the first and second liquid materials.
6. The method of any one of items 1 to 5, further comprising the step of forming a  
5 base layer (10) that extends along the entire length of the cannula's body by dispensing a third liquid material onto the mandrel (7), wherein the base layer (10) is preferably formed by dispensing a substantially uniform amount of the third liquid material with respect to the length of the mandrel (7), wherein the base layer (10) preferably has a thickness of about 50  $\mu\text{m}$  to 100  $\mu\text{m}$ , when dried.
- 10 7. The method of any one of items 1 to 6, further comprising the step of forming a stiffening structure (16) by dispensing a fourth liquid material in a helical path on the mandrel (7), wherein the first and second liquid materials are preferably dispensed both before and after dispensing the fourth material so as to embed the stiffening structure (16) in the cannula's body.
- 15 8. The method of any one of items 1 to 7, wherein at least one of the first and second liquid materials comprises a solvent that evaporates after dispensing the first and second liquid materials, respectively, wherein the proportion of the solvent is at least 70 vol%, preferably at least 80 vol%, more preferably at least 90 vol%.
9. The method of any one of items 1 to 8, wherein at least one of the first and second  
20 axial sections (13, 15) is formed by dispensing at least five, preferably at least ten, up to twenty layers of the first and second liquid materials, respectively.
10. The method of any one of items 1 to 9, wherein the mandrel (7) has a circumferential shoulder (24) interconnecting two axially adjacent parts (7a, 7b) of the mandrel (7) with different diameters, wherein the two axially adjacent parts (7a, 7b) of  
25 the mandrel (7) are preferably separated from each other to remove the cannula (4) from the mandrel (7).
11. The method of any one of items 1 to 10, further comprising the step of forming at least one marking (17) arranged on the cannula's body, wherein the at least one marking

is visually perceptible or radiopaque, wherein the at least one marking (17) is preferably formed by dispensing a liquid material by means of the dispenser (8).

12. The method of any one of items 1 to 11, further comprising the step of forming a lumen (19) extending in the wall of the cannula's body by embedding an elongate  
5 element (20) in the wall of the cannula's body.

13. The method of any one of items 1 to 12, further comprising the step of forming at least one aperture in the cannula's body by dispensing a liquid material onto the mandrel (7), optionally without rotating the mandrel (7) while dispensing said liquid material.

10 14. The method of any one of items 1 to 13, further comprising the step of attaching the cannula (4) to a housing (1a) of a pumping device (1) of an intravascular blood pump.

15. A cannula (4) for an intravascular blood pump, obtainable by the method of any one of items 1 to 14, the cannula (4) having an elongate tubular body with a blood flow  
15 inlet and a blood flow outlet, the body comprising a first axial section (13) comprising a first material and a second axial section (15) comprising a second material, wherein the first and second axial sections (13, 15) have different bending stiffnesses, and wherein the first and second materials blend into each other in a transition area (14).

16. The cannula of item 15, wherein the first axial section (13) has a first wall  
20 thickness, and the second axial section (15) has a second wall thickness, the first and second axial sections (13, 15) differing in at least one of the material and the wall thickness, wherein the different bending stiffnesses result from at least one of the differing materials and the differing wall thicknesses.

17. The cannula of item 15 or 16, wherein the first and second materials are different  
25 and axially overlap in the transition area (14).

18. The cannula of any one of items 15 to 17, wherein the first axial section (13) is a proximalmost section or a distalmost section of the cannula's body and has a greater

bending stiffness than the second axial section (15) or the rest of the elongate tubular body.

19. The cannula of any one of items 15 to 18, wherein the elongate tubular body comprises an embedded stiffening structure (16) made of a plastic material.

5 20. The cannula of any one of items 15 to 19, wherein the elongate tubular body comprises a helical wire, preferably made of metal, more preferably made of Nitinol.

21. The cannula of any one of items 15 to 20, comprising at least one marking (17) extending on or embedded in the elongate tubular body, wherein the at least one marking (17) is visually perceptible or radiopaque.

10 22. The cannula of any one of items 15 to 21, wherein the elongate tubular body has a circumferential shoulder (18) interconnecting two axially adjacent sections of the elongate tubular body with different diameters.

23. The cannula of any one of items 15 to 22, wherein the elongate tubular body comprises at least one lumen (19) extending in a wall of the elongate tubular body.

15 24. The cannula of any one of items 15 to 23, wherein the elongate tubular body has a wall thickness in the range from about 50  $\mu\text{m}$  to about 500  $\mu\text{m}$ .

25. The cannula of any one of items 15 to 24, attached to a housing (1a) of a pumping device (1) of an intravascular blood pump.

20 26. An intravascular blood pump for percutaneous insertion into a patient's blood vessel, comprising a cannula (4) of any one of items 15 to 25.

FIG 1

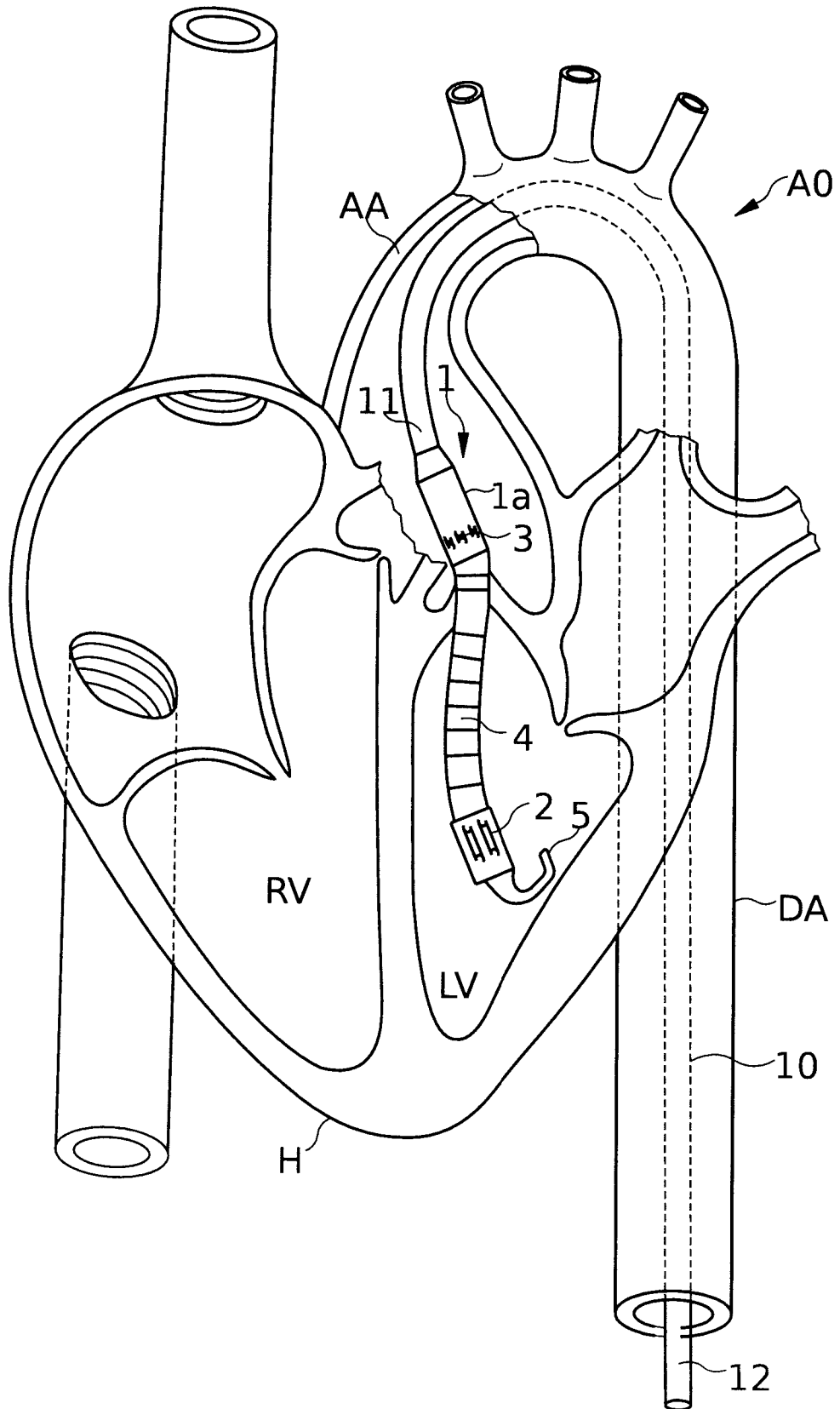

FIG 2

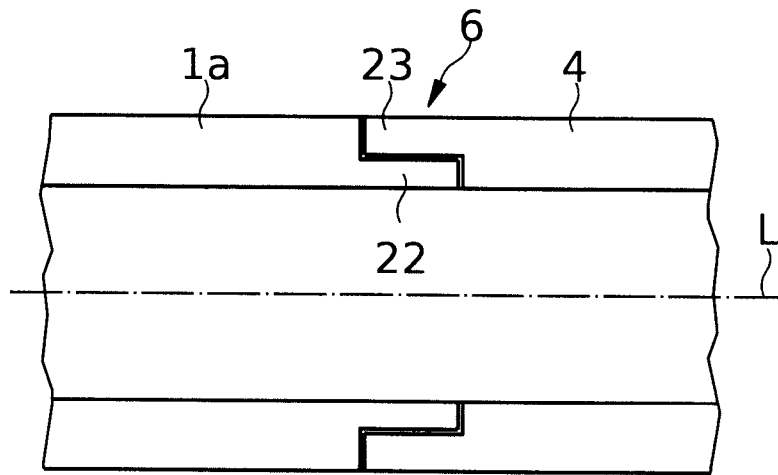

FIG 3a

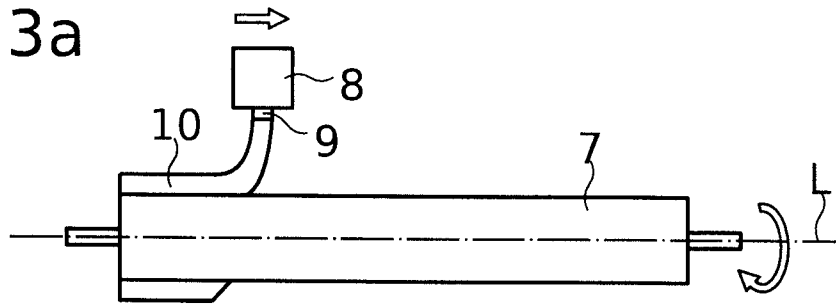

FIG 3b

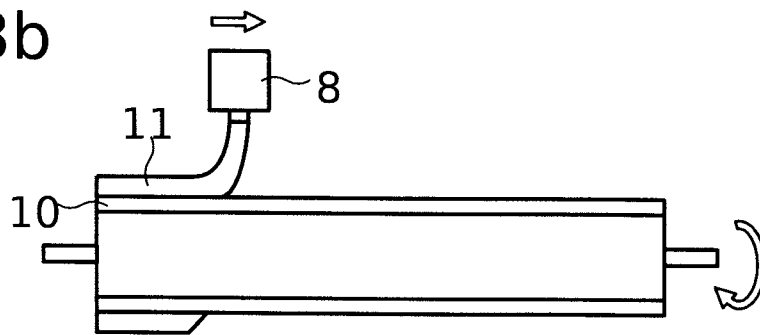

FIG 3c

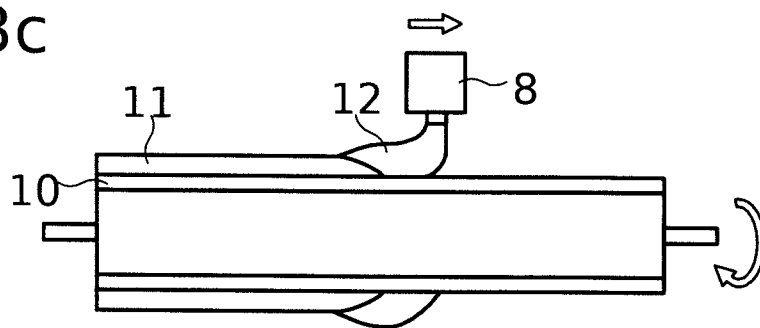

FIG 3d

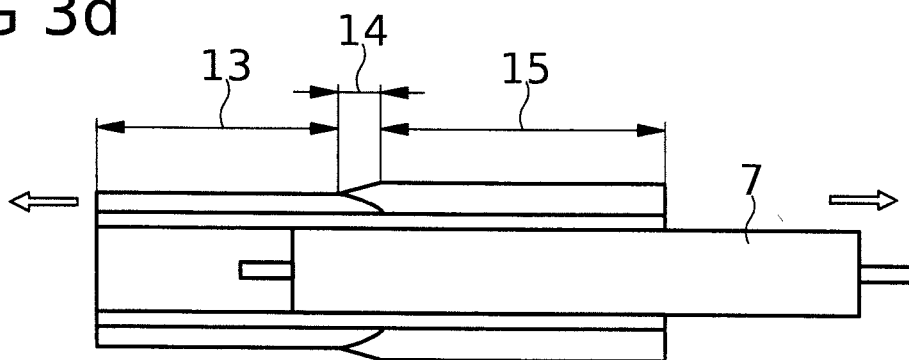

FIG 4a

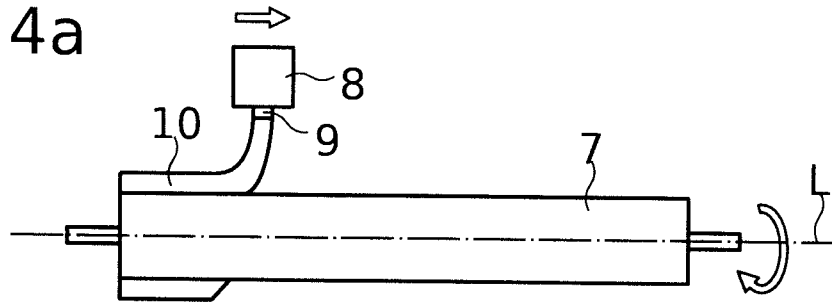

FIG 4b

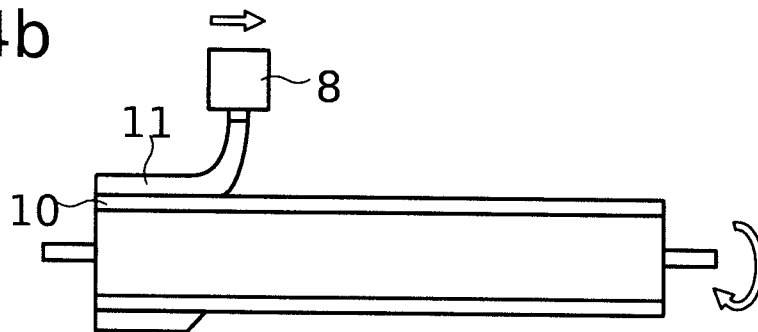

FIG 4c

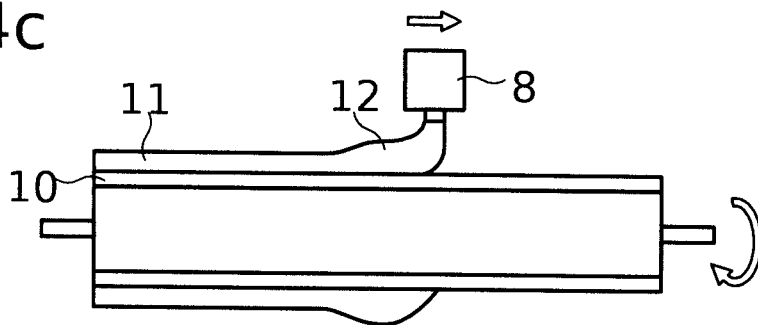

FIG 4d

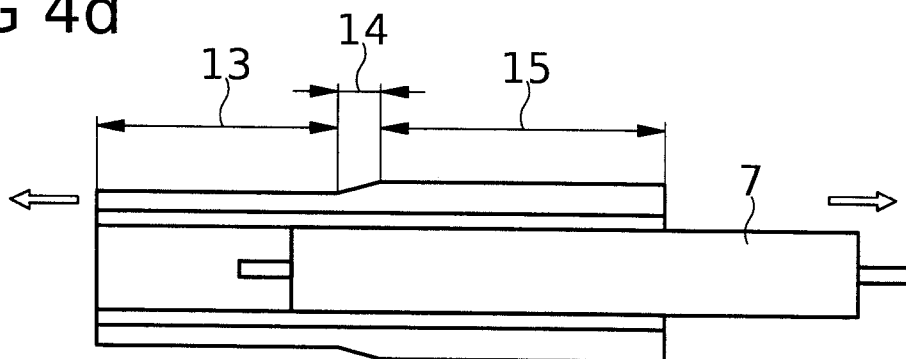



FIG 5a

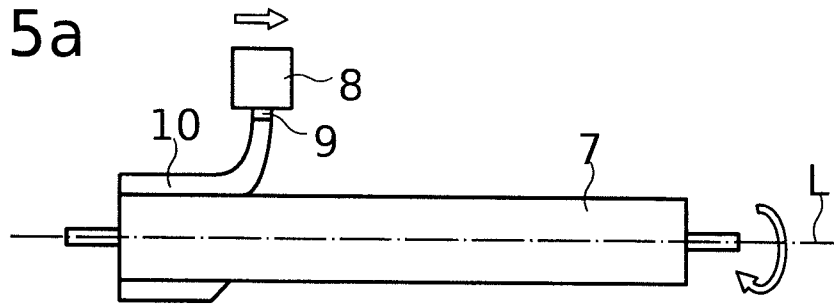

FIG 5b

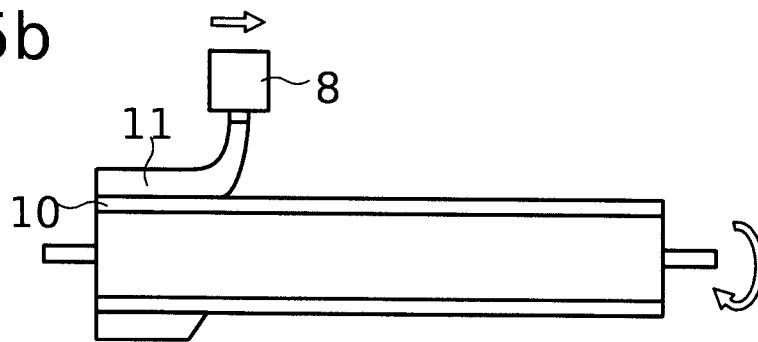

FIG 5c

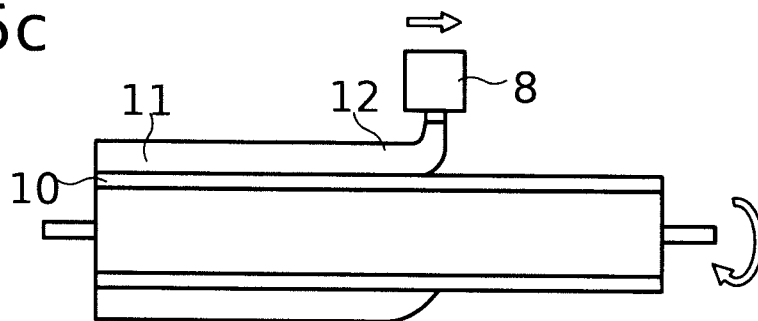

FIG 5d

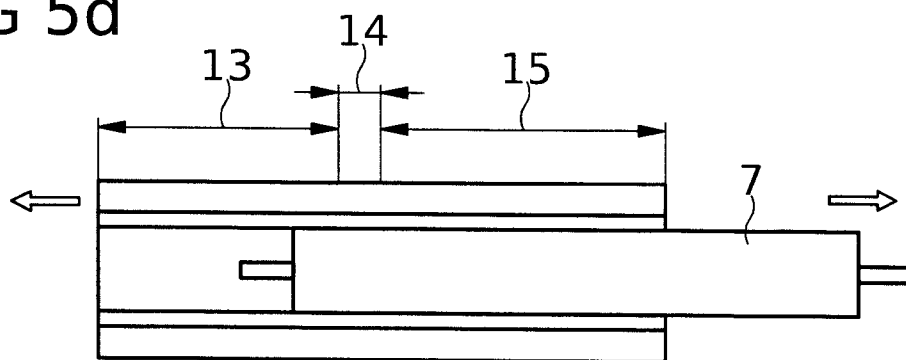

FIG 6

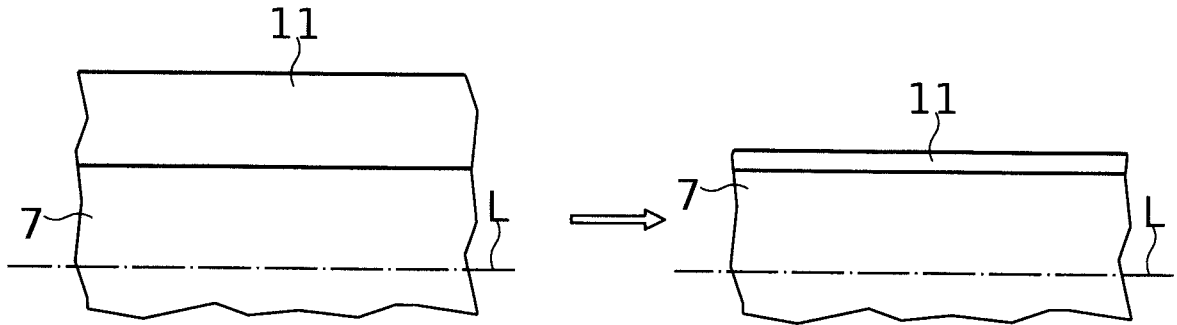

FIG 7

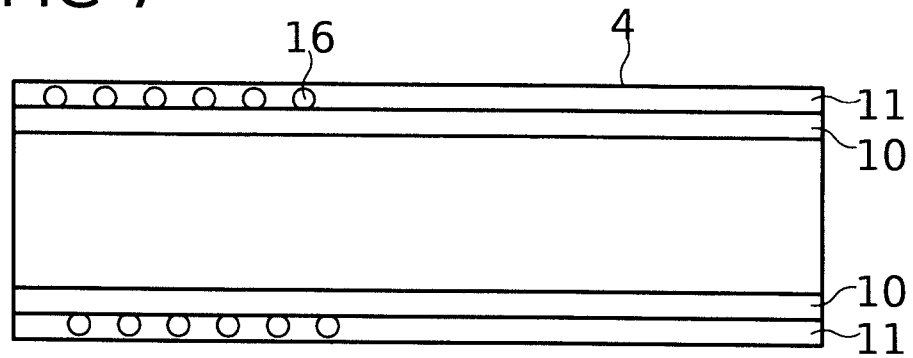

FIG 8

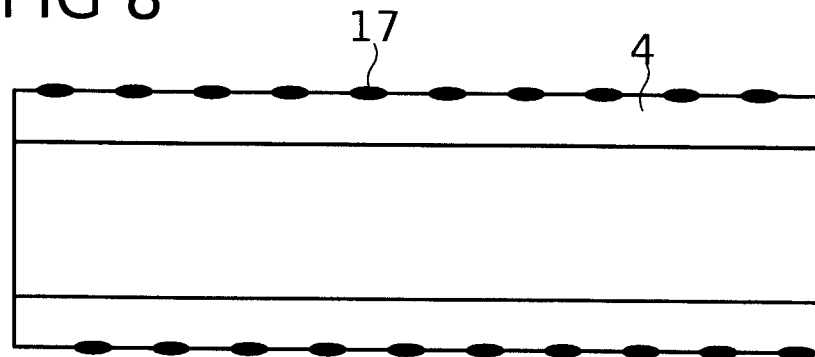

FIG 9

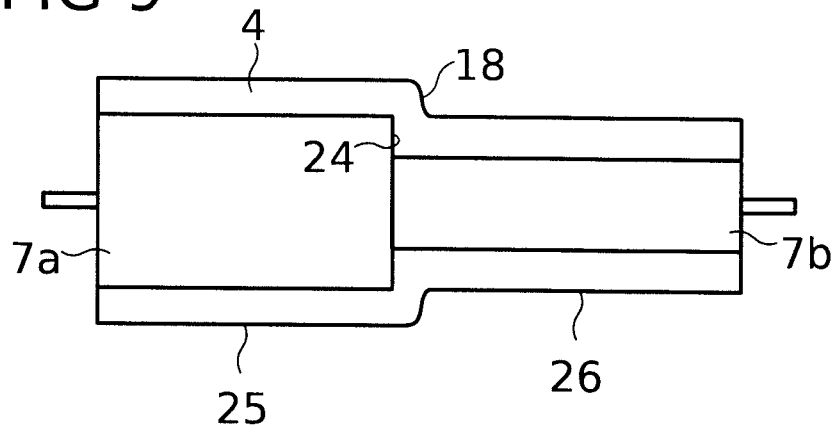

FIG 10

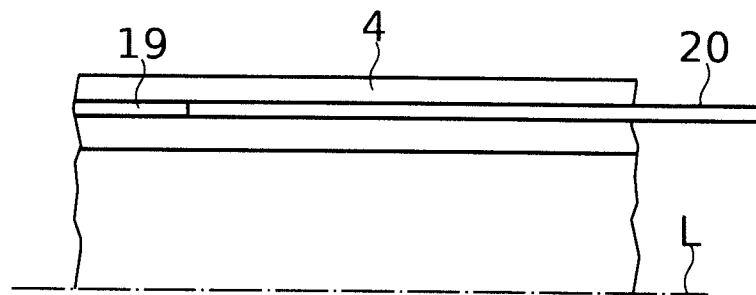
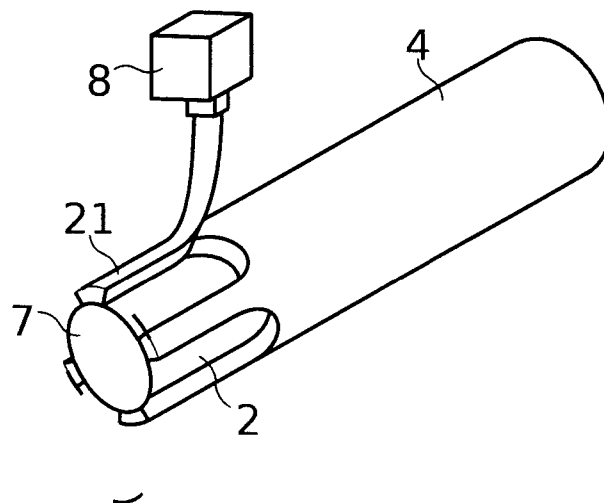

FIG 11



INTERNATIONAL SEARCH REPORT

International application No  
PCT/EP2018/066590

A. CLASSIFICATION OF SUBJECT MATTER  
INV. A61M1/10 A61M1/12  
ADD.  
According to International Patent Classification (IPC) or to both national classification and IPC

B. FIELDS SEARCHED  
Minimum documentation searched (classification system followed by classification symbols)  
A61M  
Documentation searched other than minimum documentation to the extent that such documents are included in the fields searched

Electronic data base consulted during the international search (name of data base and, where practicable, search terms used)  
EPO-Internal, WPI Data

C. DOCUMENTS CONSIDERED TO BE RELEVANT

| Category* | Citation of document, with indication, where appropriate, of the relevant passages  | Relevant to claim No.   |
|-----------|---|-------------------------|
| X<br>A    | US 2012/172655 A1 (CAMPBELL ROBERT L [US] ET AL) 5 July 2012 (2012-07-05)<br>a thicker or less compliant coating can be provided over a portion of the length of the housing to enhance the stiffness in the coated region;<br>paragraphs [0012], [0134], [0144];<br>figures 26-29<br>The compliance of the coating can therefore be modulated by selecting a coating material with the desired material properties, by modulating the thickness of the coating, and determining the appropriate cell size in which the coating is formed, as discussed herein.;<br>paragraph [0131]<br>-----<br>-/-- | 15-22,<br>24-26<br>1-14 |

Further documents are listed in the continuation of Box C.

See patent family annex.

\* Special categories of cited documents :

- "A" document defining the general state of the art which is not considered to be of particular relevance
- "E" earlier application or patent but published on or after the international filing date
- "L" document which may throw doubts on priority claim(s) or which is cited to establish the publication date of another citation or other special reason (as specified)
- "O" document referring to an oral disclosure, use, exhibition or other means
- "P" document published prior to the international filing date but later than the priority date claimed

"T" later document published after the international filing date or priority date and not in conflict with the application but cited to understand the principle or theory underlying the invention

"X" document of particular relevance; the claimed invention cannot be considered novel or cannot be considered to involve an inventive step when the document is taken alone

"Y" document of particular relevance; the claimed invention cannot be considered to involve an inventive step when the document is combined with one or more other such documents, such combination being obvious to a person skilled in the art

"&" document member of the same patent family

|   |   |
|---|---|
| Date of the actual completion of the international search<br><b>9 August 2018</b> | Date of mailing of the international search report<br><b>17/08/2018</b> |
|---|---|

|  |   |
|--|---|
| Name and mailing address of the ISA/<br>European Patent Office, P.B. 5818 Patentlaan 2<br>NL - 2280 HV Rijswijk<br>Tel. (+31-70) 340-2040,<br>Fax: (+31-70) 340-3016 | Authorized officer<br><b>Van Veen, Jennifer</b> |
|--|---|

## INTERNATIONAL SEARCH REPORT

International application No  
PCT/EP2018/066590

| C(Continuation). DOCUMENTS CONSIDERED TO BE RELEVANT |  |                         |
|--|--|-------------------------|
| Category*  | Citation of document, with indication, where appropriate, of the relevant passages   | Relevant to claim No.   |
| X<br>A   | <p>US 2014/012065 A1 (FITZGERALD KEIF M [US] ET AL) 9 January 2014 (2014-01-09)<br/>s, the cannula is differentiated along its length to have varying stiffness;<br/>paragraph [0011]<br/>coating; spinning on a mandrel;<br/>paragraph [0057]<br/>By providing longer connectors 228A, enhanced stiffness can be provided in the impeller zone 212.<br/>The helical zones 260 provide enhanced concentration of material around the proximal apices 232B of circumferential members 224 in the impeller zone 212.<br/>Enhanced concentration of material provides enhanced local stiffness around the proximal apices 232B, which provides greater stiffness and protects the proximal apices 232B and connectors disposed thereon from fracture.;<br/>paragraphs [0063] - [0065]; figure 5<br/>-----</p> | 15-22,<br>24-26<br>1,23 |
| A  | <p>US 2016/279310 A1 (SCHECKEL MARIO [DE] ET AL) 29 September 2016 (2016-09-29)<br/>paragraph [0057]; figures 4A,B<br/>-----</p>   | 1,15                    |
| A  | <p>US 2015/328382 A1 (CORBETT SCOTT C [US] ET AL) 19 November 2015 (2015-11-19)<br/>paragraph [0019]<br/>-----</p>   | 1,15                    |

# INTERNATIONAL SEARCH REPORT

Information on patent family members

|   |
|---|
| International application No<br>PCT/EP2018/066590 |
|---|

| Patent document cited in search report | Publication date | Patent family member(s) | Publication date |
|--|------------------|-------------------------|------------------|
| US 2012172655 A1                       | 05-07-2012       | AU 2012204321 A1        | 25-07-2013       |
|  |                  | CA 2823950 A1           | 12-07-2012       |
|  |                  | EP 2661303 A2           | 13-11-2013       |
|  |                  | TW 201247254 A          | 01-12-2012       |
|  |                  | US 2012172655 A1        | 05-07-2012       |
|  |                  | WO 2012094525 A2        | 12-07-2012       |
|  |                  | -----                   |                  |
| US 2014012065 A1                       | 09-01-2014       | EP 2869866 A1           | 13-05-2015       |
|  |                  | US 2014012065 A1        | 09-01-2014       |
|  |                  | US 2016279309 A1        | 29-09-2016       |
|  |                  | WO 2014008105 A1        | 09-01-2014       |
| -----                                  |                  |                         |                  |
| US 2016279310 A1                       | 29-09-2016       | CA 2928161 A1           | 07-05-2015       |
|  |                  | CN 105682699 A          | 15-06-2016       |
|  |                  | CN 108310496 A          | 24-07-2018       |
|  |                  | DE 202014010832 U1      | 23-12-2016       |
|  |                  | EP 2868331 A2           | 06-05-2015       |
|  |                  | EP 2999496 A2           | 30-03-2016       |
|  |                  | EP 3127563 A1           | 08-02-2017       |
|  |                  | HK 1223867 A1           | 11-08-2017       |
|  |                  | JP 2016538981 A         | 15-12-2016       |
|  |                  | KR 20160078397 A        | 04-07-2016       |
|  |                  | US 2016279310 A1        | 29-09-2016       |
|  |                  | WO 2015063277 A2        | 07-05-2015       |
| -----                                  |                  |                         |                  |
| US 2015328382 A1                       | 19-11-2015       | CA 2947985 A1           | 19-11-2015       |
|  |                  | EP 3142721 A1           | 22-03-2017       |
|  |                  | JP 2017515581 A         | 15-06-2017       |
|  |                  | US 2015328382 A1        | 19-11-2015       |
|  |                  | US 2018104398 A1        | 19-04-2018       |
|  |                  | WO 2015175718 A1        | 19-11-2015       |
| -----                                  |                  |                         |                  |