

(19) World Intellectual Property Organization
International Bureau



(43) International Publication Date
16 March 2006 (16.03.2006)

PCT

(10) International Publication Number
WO 2006/029232 A2

(51) International Patent Classification:
B41J 25/312 (2006.01) *B41J 2/32* (2006.01)

(74) Agents: **KIRK, Trent, A.** et al.; Alston & Bird LLP, Bank of America Plaza, 101 South Tryon Street, Suite 4000, Charlotte, NC 28280-4000 (US).

(21) International Application Number:
PCT/US2005/031919

(81) Designated States (*unless otherwise indicated, for every kind of national protection available*): AE, AG, AL, AM, AT, AU, AZ, BA, BB, BG, BR, BW, BY, BZ, CA, CH, CN, CO, CR, CU, CZ, DE, DK, DM, DZ, EC, EE, EG, ES, FI, GB, GD, GE, GH, GM, HR, HU, ID, IL, IN, IS, JP, KE, KG, KM, KP, KR, KZ, LC, LK, LR, LS, LT, LU, LV, MA, MD, MG, MK, MN, MW, MX, MZ, NA, NG, NI, NO, NZ, OM, PG, PH, PL, PT, RO, RU, SC, SD, SE, SG, SK, SL, SM, SY, TJ, TM, TN, TR, TT, TZ, UA, UG, US, UZ, VC, VN, YU, ZA, ZM, ZW.

(22) International Filing Date:
6 September 2005 (06.09.2005)

(25) Filing Language: English

(26) Publication Language: English

(30) Priority Data:
60/607,674 7 September 2004 (07.09.2004) US

(84) Designated States (*unless otherwise indicated, for every kind of regional protection available*): ARIPO (BW, GH, GM, KE, LS, MW, MZ, NA, SD, SL, SZ, TZ, UG, ZM, ZW), Eurasian (AM, AZ, BY, KG, KZ, MD, RU, TJ, TM), European (AT, BE, BG, CH, CY, CZ, DE, DK, EE, ES, FI, FR, GB, GR, HU, IE, IS, IT, LT, LU, LV, MC, NL, PL, PT, RO, SE, SI, SK, TR), OAPI (BF, BJ, CF, CG, CI, CM, GA, GN, GQ, GW, ML, MR, NE, SN, TD, TG).

(71) Applicant (*for all designated States except US*): **ZIH CORP.** [US/—]; Pearman Building, 3 Gorham Road, 3rd Floor, Hamilton Parish (BM).

(72) Inventors; and

(75) Inventors/Applicants (*for US only*): **BOISDON, Olivier** [FR/FR]; 6 rue des Acacias, F-49170 Saint-Leger-des Bois (FR). **PELLETIER, Joël** [FR/FR]; 17 Avenue Fond Léger, F-49480 Saint Sylvain d'Anjou (FR). **HONAR-YAR, Babak** [—/US]; 177 Camino Pablo, Orinda, CA 94563 (US). **SMITH, Marty** [—/US]; 12451 Ridge Drive, Santa Rosa Valley, CA 93012 (US). **CHAVARRIA, Lionel** [US/US]; 12691 Misty Grove Street, Moorpark, CA 93021 (US).

Published:

— *without international search report and to be republished upon receipt of that report*

For two-letter codes and other abbreviations, refer to the "Guidance Notes on Codes and Abbreviations" appearing at the beginning of each regular issue of the PCT Gazette.

(54) Title: APPARATUS FOR FLOATING PRINT HEAD AND ASSOCIATED METHOD

(57) Abstract: The present invention provides a floating print head assembly and an associated method. According to one embodiment, the floating print head assembly includes a head bracket and a print head attached to the bracket such that the print head is suspended above the printing substrate. The assembly also includes an alignment mechanism disposed within the head bracket, where the alignment mechanism is operable to pivot such that the print head is capable of pivoting to apply substantially uniform print pressure across a substrate.

WO 2006/029232 A2

APPARATUS FOR A FLOATING PRINT HEAD AND ASSOCIATED METHOD

BACKGROUND OF THE INVENTION

1. Field of the Invention.

The present invention relates generally to a floating print head and an associated method for aligning the print head for thermal printing.

2. Description of Related Art.

Thermal printers may be used to print a variety of configurations on substrates, such as cards and webs. A thermal printer typically includes a thermal print head having a row of resistors that may be activated to produce heat that is transferred to a print ribbon having thermally reactive ink or dyes and onto the substrate. One or more platen rollers is typically employed to transfer the substrate to print an array of rows to create an image or graphic, as well as to provide a support surface when the print head prints onto the substrate.

Given the increasing complexity of configurations printed on a substrate, such as images or graphics, the alignment of the print head becomes more important. It is desirable to have the line of resistors substantially aligned relative to the centerline of the platen roller to achieve a consistent print or dot line across the substrate. Because each of the multiple components that comprise the printer may have an associated tolerance, there is a greater probability of mismatching between the line of resistors and the platen as the tolerances stack up and make alignment difficult. Moreover, typical thermal printers do not allow for the print head to adjust once the print head is in a printing position, which makes realignment of the print head difficult, if not impossible.

Techniques have been developed to align the print head for thermal printing. For example, U.S. Patent No. RE38,473 to Smolenski discloses a printer having a floating print head with alignment surfaces to position the print head. The print head is spring loaded to allow the print head to float in a vertical and horizontal direction within a lid assembly. In particular, the printer includes alignment posts having an oblique angle that corresponds to an angle on a print head alignment surface that compensates for linear and rotational misalignment.

The print head includes a leaf spring, and as the print head is lowered, the print head alignment surface contacts a guide post alignment surface in the body of the printer. Because the alignment surfaces contact at oblique angles, there is a certain amount of tolerance in the approach positions between the alignment surfaces provided by the leaf spring. However, although the floating print head allows for translational and pitch alignment, the floating print head may not facilitate rolling adjustment about a longitudinal axis. As such, the Smolenski patent may not ensure that the line of resistors are both aligned relative to the centerline of the platen roller and that each of the resistors applies uniform pressure and thermal transfer across the substrate.

For these and other reasons, it would be advantageous to provide a floating print head assembly that is capable of applying uniform pressure across the substrate. Furthermore, it would be advantageous to provide a floating print head assembly that may compensate for tolerances inherent in the thermal printer assembly. It would also be advantageous to provide a floating print head assembly that is easily operated and assembled.

BRIEF DESCRIPTION OF THE SEVERAL VIEWS OF THE DRAWING(S)

Having thus described the invention in general terms, reference will now be made to the accompanying drawings, which are not necessarily drawn to scale, and wherein:

FIG. 1 is perspective view of a thermal printer, according to one embodiment of the present invention;

FIG. 2 is a perspective view of thermal printer shown in **FIG. 1**, illustrating various features of the thermal printer, according to one embodiment of the present invention;

FIG. 3 is an another perspective view of the thermal printer shown in **FIG. 2** illustrating the various features of the thermal printer;

FIG. 4 is an exploded perspective view of a floating print head assembly, according to one embodiment of the present invention;

FIG. 5 is another exploded perspective view of a floating print head assembly, according to an additional embodiment of the present invention;

FIG. 6 is a side elevation view of the floating print head assembly shown in **FIG. 5** illustrating the floating print head assembly partially assembled and in a partially opened position;

FIG. 7 is a side elevation view of the floating print head assembly shown in **FIG. 4** illustrating the floating print head assembly fully assembled and in an open, non-printing position;

FIG. 8 is a cross-sectional plan view of the floating print head assembly shown in **FIG. 4**;

FIG. 9A is a perspective view of a user opening a cover of the thermal printer shown in **FIG. 1**, according to one embodiment of the present invention;

FIG. 9B is a perspective view of the thermal printer after the user has opened the cover, according to one embodiment of the present invention;

FIG. 10A is a side elevation view of the floating print head assembly in a printing position, according to one embodiment of the present invention;

FIG. 10B is a side elevation view of the floating print head assembly in a non-printing position, according to one embodiment of the present invention;

FIG. 11A is a side elevation view of the floating print head assembly in an open position and a perspective view of a pair of rollers having a ribbon disposed thereon, according to one embodiment of the present invention;

FIG. 11B is a perspective view of a thermal printer with the floating print head assembly in an open position and the rollers and ribbon installed within the thermal printer, according to one embodiment of the present invention;

FIG. 11C is a side elevation view illustrating a user moving the floating print head assembly from an open position to a printing position, according to one embodiment of the present invention;

FIG. 11D is a side elevation view showing the floating print head assembly of **FIG. 11C** in a printing position, according to one embodiment of the present invention;

FIG. 12A is a side elevation view illustrating a floating print head assembly and a lever for applying a print head force to the floating print head assembly, according to another embodiment of the present invention; and

FIG. 12B is a side elevation view of the floating print assembly of **FIG. 12A** in a printing position.

DETAILED DESCRIPTION OF THE INVENTION

The present invention now will be described more fully hereinafter with reference to the accompanying drawings, in which some, but not all embodiments of the invention are shown. Indeed, this invention may be embodied in many different forms and should not be construed as limited to the embodiments set forth herein; rather, these embodiments are provided so that this disclosure will satisfy applicable legal requirements. Like numbers refer to like elements throughout.

The present invention addresses the above needs and achieves other advantages by providing a thermal printer **10**, as shown in **FIG. 1**, that is capable of printing substrates having uniform print quality. In particular, the thermal printer **10** includes a floating print head assembly **11** having an alignment mechanism **12** that allows a floating print head **14** to align itself and apply uniform pressure across a substrate, which results in uniform thermal transfer between the print head and a ribbon to print a variety of configurations on the substrate having a consistent print quality.

Thermal printers, as known to those skilled in the art, typically include a print head having heating resistors thereon, rollers for transferring a ribbon, and a platen roller to transfer a substrate adjacent to the print head such that heat transferred from the heating resistors is transferred to the ribbon. The heated ribbon generally includes thermally reactive ink or dye that is then transferred onto the substrate. The substrates, such as smart cards, labels, identification cards, and the like, are made of a variety of materials (*e.g.*, PVC or composite materials), could be fed individually into the thermal printer, or there may be a stack of substrates that are fed from a card feeder, such as that shown in **FIGS. 2-3**, to one or more platen rollers. As also depicted in **FIGS. 2-3**, the thermal printer may include any number of additional components, such as an encoder for encoding contactless and contact smart cards, a magnetic card stripe encoder, a smart card or magnetic stripe reader, a substrate output hopper, and/or a cleaning station having a cleaning cartridge, where individual substrates are cleaned prior to being transferred by the platen rollers to the print head. However, other mechanisms could be employed to transfer the substrate to the print head or during printing, such as belts, tracks, or carriages.

FIG. 4 illustrates a floating print head assembly **11** including an alignment mechanism **12** having a print head **14** attached to a head bracket **16**. The floating

print head assembly 11 is pivotally attached to the thermal printer 10 through an axis A defined in a pivot bracket through a pivot bracket shaft. The head bracket 16 and print head 14 are pivotally connected to the pivot bracket 18 at axis B, where the head bracket and print head may rotate about multiple axes (e.g., pitch, roll, and yaw) defined by the alignment mechanism 12.

The floating print head assembly 11 includes a print head support 20, where the print head 14 may attach thereto. The head bracket 16 defines a cavity that allows the print head support 20 to fit therein when assembled. The print head support 20 includes a shaft 22 and an adjustment screw 24 and adjustment spring 25 that may engage a threaded portion in the shaft substantially perpendicular to the longitudinal axis of the shaft. The print head support 20 also includes a screw 26 that may engage an end of the shaft 22 along a longitudinal axis of the shaft. Each lateral edge of the print head support 20 further includes one or more detents 28 extending outwardly from the print head support.

The print head support 20 is typically a heat sink, such as die cast aluminum, that is used to conduct heat away from the print head 14. To transfer excessive heat away from the print head 14, the print head support 20 may include one or more fins 30. Typically, the floating print head assembly 11 includes a fan 32, such as a whisper fan or similar electric fan, that aids in drawing heat away from the print head 14. As shown in FIG. 4, the fan 32 is mounted within the head bracket 16 proximate to a grate 34 to draw heat away from the print head 14 and through the head bracket. The grate 34 is preferably defined in the head bracket 16 so that heat may dissipate through openings defined in the grate and away from the floating print head assembly 11. In FIG. 4, the grate 34 is shown defined in a top portion of the head bracket 16, although the grate could be defined in any convenient location on the head bracket. To provide power to generate heat in the print head 14 and operate the fan 32, wiring 33 and associated conduit is provided, as shown in FIG. 7.

A peel bar 74 and a film bar 76 are attached to the print head support 20, as shown in FIGS. 4 and 7. The peel bar 74 is attached to the print head support 20 with screws 78, while the film bar 76 is attached to the print head support with screws 80. The peel bar 74 is used to peel the ribbon off of a substrate and control noise when removing the ribbon, while the film bar 76 creates a smooth contact for the ribbon as a first end of the ribbon extends along the film bar and print head 14

and along the peel bar to a second end of the ribbon. Moreover, the film bar 76 may function as an optically reflective surface for ribbon color LED's for identifying different panel colors for a full color ribbon. The peel bar 74 and film bar 76 are typically sheet metal or similar material to provide a smooth contact surface for the ribbon.

The adjustment screw 24 is utilized to adjust the print head support 20 and print head 14 about a x-axis (*i.e.*, pitch). The adjustment screw 24 is typically adjusted to a predetermined position based on a manufacturer's specifications, such that further adjustments are not usually required once initially set. The adjustment screw 24 may be rotated to adjust the print head 14 angle to ensure that a line of resistors on the print head align with a platen roller positioned adjacent to a ribbon and a substrate. Thus, the dot line produced by the print head 14 is not fixed and may also be adjusted to achieve various degrees of pressure across the substrate by adjusting the position of the print head. The print head 14 may be adjusted linearly and/or about a z-axis (*i.e.*, yaw) with a pair of screws (not shown), where a screw driver or other adjustment device may be inserted through slots 36 defined in the head bracket 16 to access the screws extending through the print head support 20 and into the print head 14. Once the screws are loosened, the print head 14 may be adjusted linearly and/or about a z-axis and the screws retightened to secure the print head in a desired position.

The head bracket 16 includes arcuate slots 38 that mate with the screw 26 and detents 28 of the print head support 20, as illustrated in FIG. 7. In particular, the detents 28 engage the upper and lower arcuate slots 38, while the screw 26 engages an arcuate slot located between the upper and lower slots. The screw 26 and detents 28 engage the arcuate slots 38 such that the print head support 20 may pivot about an x-axis (*i.e.*, pitch) along the arcuate slots. As such, the arcuate slots 38 restrict the degree of pitch that the print head support 20 may be rotated. The arcuate slots 38 are defined in respective lateral edges 40 of the head bracket 16 such that the print head support 20 may engage each of the lateral edges. In general, a position along the midpoint of the arcuate slots 38 corresponds to a centerline of a platen roller positioned adjacent to the print head 14.

The head bracket 16 also defines a latch slot 46, where a latch button 48 is sized and configured to insert through the latch slot. The latch button 48 is operatively connected to a latch 50 such that the latch button may be depressed to

activate the latch. Thus, a distal edge **44** of the head bracket **16** includes an aperture that is sized and configured to allow the latch **50** to extend therethrough and engage the pivot bracket **18**, as depicted in **FIG. 8**. The latch **50** includes a latch spring **52** that forces the latch to engage the pivot bracket, and as the latch button **48** is depressed, the latch spring is biased and the latch moved out of engagement with the pivot bracket **18**. The head bracket **16** may include a spring aperture **53** sized and configured for the latch spring **52**, such that when the latch spring relaxes and extends within the spring aperture to a predetermined position and spring force, the latch **50** is forced to engage the pivot bracket **18**.

FIG. 5 illustrates that the pivot bracket **18** includes a pivot slot **54** that allows an engaging end **55** of the latch **50** to extend therein. The engaging end **55** is preferably in a fork-like configuration to engage the pivot slot **54**, although the engaging end could be any desired configuration that is capable of engaging the pivot slot in alternative embodiments of the present invention. The pivot slot **54** is preferably sized and configured to also allow the engaging end **55** of the latch **50** to pivot therein such that the pivot slot defines an arcuate curvature and is larger than the relative width of the engaging end. It is understood that the pivot slot **54** could be various configurations for facilitating engagement of the engaging end **55** and allowing the engaging end to pivot therein. For example, the pivot slot **54** could include a bearing that receives the engaging end **55** to allow rotation about a roll axis.

The floating print head assembly **11** also includes a sensor **57**, such as an infrared sensor, that may be used to detect when the latch **50** has slid through the head bracket **16** to an unlatched or disengaged position. In one embodiment, the sensor **57** is attached to the head bracket **16** such that the latch **50** may slide through a notch defined in the sensor. When the latch **50** is disengaged with the pivot bracket **18**, the sensor **57** detects when the latch has moved beyond a designated position and sends a signal to the thermal printer **10** to not print since the print head **14** is in a non-printing position.

The floating print assembly **11** includes an alignment mechanism **12** that generally includes a ball joint shaft **56** and a ball joint cap **58**. The ball joint shaft **56** defines various diameters along the axis of the shaft and includes a ball **60** positioned approximately about the midpoint of the shaft, although the ball could be positioned at various locations along the ball joint shaft. The ball **60** is sized

and configured to fit within a socket 62 defined in the ball joint cap 58 such that the head bracket 16 and ball joint cap 58 are capable of pivoting about a x, y, and z-axis. The ball 60 could be integral with, or separately attached to, the ball joint shaft 56. As shown in FIG. 8, the head bracket 16 includes a similar socket 63 that mates with the socket 62 and the ball joint cap 58, which allows the head bracket and ball joint cap to pivot about the ball 60 between each socket. Generally, the diameter of the sockets 62, 63 are substantially similar to that of the ball 60 to permit rotation of the head bracket 16 and ball joint cap 58 thereabout. It is understood that the ball joint shaft 56 could include other suitable pivot members for facilitating rotation, such as a roller or bearing that mates with the head bracket 16 and/or ball joint cap 58 and allows rotation about a roll axis. Thus, the head bracket 16 and ball joint cap 58 could be any desired configuration for cooperating with the ball joint shaft 56 to facilitate rotation about one or more axes.

The head bracket 16 includes a slot 64 defined in each lateral edge 40, where the slots are preferably arcuate to correspond to a radius of the ball joint shaft 56, such that the ball joint shaft may fit within the slots. The ball joint shaft 56 extends through openings 66 defined in the pivot bracket 18. As shown in FIG. 4, one opening 66 defined in the pivot bracket 18 is smaller in diameter than a second opening. The smaller diameter portion of the ball joint shaft 56 is sized and configured to fit within the smaller opening 66 defined in the pivot bracket 18, while the larger diameter portion of the ball joint shaft fits within the larger diameter opening. As such, the ball joint shaft 56 fits within the openings 66 defined in the pivot bracket 18 and the slots 64 defined in the head bracket 16 such that the ball joint shaft is secured therein, while the head bracket 16 and ball joint cap 58 may rotate about a x, y, and/or z axis as the sockets 62 and 63 pivot about the ball 60. It is understood that the slots 64 and openings 66 could be any size and configuration in additional embodiments of the present invention. For example, there could be a single opening 66 such that the ball joint shaft 56 extends completely within the opening, and the openings could be separate but the same diameter.

Although the alignment mechanism 12 is shown to extend along axis B, it is understood that the alignment mechanism could be positioned at various locations. For example, the alignment mechanism 12 could extend along axis A or along shaft 22. Thus, the alignment mechanism 12 could be located at various

locations to achieve a desired amount of rotation about one or more axes to allow the print head 14 to apply uniform pressure on the substrate during printing.

When the ball joint shaft 56 is inserted within the openings 66 defined in the pivot bracket 18, the ball joint cap 58 is assembled to the head bracket 16 with a pair of screws 68. The pivot bracket 18 includes a cavity 70 such that the ball joint cap 58 may fit within the cavity and attach to the head bracket. A screw 72 is inserted within the smaller opening 66 and into the end of the ball joint shaft 56 to prevent the ball joint shaft from sliding out of the opening or out of position, and is preferably fastened flush with the pivot bracket 18.

As shown in FIGS. 12A-12B, a lever 96 may be coupled to the opposite end of the ball joint shaft 56 that includes the screw 72. The end of the ball joint shaft 56 extends through the larger diameter opening 66 such that it may engage the lever 96. Typically, the lever 96 is oriented along the z-axis and could be a rod, longitudinal plate, or similar structure, having at least two holes defined therein. An upper hole 98 is provided in the lever to couple to the ball joint shaft 56 that extends through the larger diameter opening 66 and along axis B. A middle hole 100 is provided in the lever to couple to the pivot bracket shaft through axis A. Any suitable drive or mechanism, such as a cam 104, could engage the lever to apply print head pressure through axis B, as well as cause rotation of the floating print head assembly 11 about axis A. In addition, a third or lower hole could be provided in the lever 96 to connect to the drive mechanism, which could be used to provide the print head force, as well as the rotate the assembly.

Thus, the cooperation of the ball joint shaft 56 and ball joint cap 58 of the alignment mechanism 12 permit the head bracket 16 and print head support 20 to rotate, which causes the print head 14 to rotate. Specifically, the head bracket 16, the print head support 20, and print head 14 are capable of collectively rotating about a x-axis (*i.e.*, pitch), as well as rotating about a y-axis (*i.e.*, roll) and about a z-axis (*i.e.* yaw). Preferably, the print head 14 is fixed in pitch and yaw while in a printing position, but the print head may adjust its roll while in a printing position by gimbaling or floating with the alignment mechanism 12. The slots 64 defined in the head bracket 16 prevent the head bracket 16 from pivoting about a y-axis more than a predetermined angle, such as between 5 and 10 degrees in one embodiment of the present invention, as the print head bracket 16 is only capable

of being pivoted until the ball joint shaft contacts an upper portion of the slot on either of the lateral edges 40 of the head bracket.

FIGS. 5 and 6 illustrate an additional embodiment of the present invention. The floating print head assembly 11 demonstrates that there may be various modifications in the design of the assembly and still be within the scope of the present invention. Thus, the size and configuration of various components of the floating print head assembly 11 could be modified to accommodate any number of thermal printers 10. For example, as depicted in **FIG. 5**, the print head support 20 may be any desired size or configuration, and the head bracket 16 could be modified as well, such as the size and configuration of the arcuate slots 38. Moreover, the ball joint shaft 56 could have various diameters or a single diameter along the shaft, as well as any diameter for the ball 60. The ball joint shaft 56 could be a series of components that are assembled to form the shaft, or the shaft could be manufactured from a single piece of material. Furthermore, the floating print head assembly 11 could include a spring 82 to apply pressure to the print head 14, and/or a spring could be positioned within the pivot bracket 18 to aid in pivoting the head bracket 16 and print head 14 between a printing position and a non-printing position.

FIGS. 7 and 8 illustrate the floating print head assembly 11 with each of its components assembled. To assemble the alignment mechanism 12 within the floating print head assembly 11, generally the latch button 48, latch 50, and latch spring 52 will first be positioned in the head bracket 16. The ball joint shaft 56 may then be inserted within the openings 66 defined in the pivot bracket 18 with the smaller diameter portion of the shaft inserted first. The ball joint shaft 56 will typically include a raised edge or similar structure on the diameter of the ball joint shaft that restricts the movement of the smaller diameter portion from traveling through the openings 66 past a designated position. A screw 72 is then inserted into one end of the ball joint shaft 56 to ensure the ball joint shaft does not slide out of the opening 66 or become misaligned. The ball joint cap 58 is then secured to the head bracket 16 with screws 68. The fan 32 and print head support 20 with the print head 14 attached thereto may then be assembled within the head bracket 16.

FIG. 7 depicts the floating print head assembly 11 in a non-printing position, where the head bracket 16 is pivoted about the ball joint shaft 56

upwardly to a predetermined position. **FIG. 8** shows the floating print head assembly **11** in a printing position, where the head bracket **16** is in a lowered position. When lowered, the curvature of the head bracket **16** and pivot bracket **18** cooperate to define an opening for a first ribbon spool **84** (see **FIG. 10A** showing the spool positioned within the opening). A ribbon **88** extends from the first ribbon spool **84**, along the film bar **76**, under the print head **14**, along a portion of the peel bar **74** and to a second ribbon spool **86**.

FIGS. 11A-D generally depict the location of the ribbon spools **84**, **86** and ribbon **88** in relation to the floating print head assembly **11**, while **FIG. 8** shows a more detailed view of the components that may be in intimate contact with the ribbon. In particular, **FIG. 8** illustrates that the film bar **76** provides a surface for the ribbon **88** to contact as the ribbon extends from the first ribbon spool and below the print head **14**. The film bar **76** typically includes a smooth radius to allow the ribbon to glide along the film bar as the ribbon spools **84**, **86** are rotated. Similarly, the peel bar **74** has a slightly angled surface **90** that provides a smooth transition for the ribbon **88** as the ribbon extends along the print head **14** and to the second ribbon spool **86**. **FIG. 8** also demonstrates that the print head **14** includes a glazed curvature surface that corresponds to a row of heated resistors **92**. The resistors **92** generate heat and transfer the heat to the ribbon **88** during printing to generate a printed dot line across the substrate.

Once assembled, the operation of the floating print head assembly **11** is predominately self-sufficient, such that a minimal amount of user intervention is required to ensure that the print head **14** is aligned and producing uniform pressure across the ribbon **88** and to a substrate. To move the floating print head assembly **11** from a printing position to a non-printing position, a cover **94** on the thermal printer **10** is raised by a user, as shown in **FIGS. 9A-B**. **FIGS. 10A-B** illustrate that as the latch button **48** is moved forwardly (as shown by arrow **1**), the floating print head assembly **11** may be raised from a printing position to a non-printing position (as shown by arrow **2**) either manually by the user or automatically, such as with a spring. Typically, once the latch button **48** is depressed the floating print head assembly **11** is locked in a non-printing position at a predetermined angle, such as 45 degrees. In the non-printing position, the ribbon spools **84**, **86** and ribbon **88** may be replaced, the print head **14** may be manually inspected and/or

cleaned, and/or the positioning of the floating print head assembly 11 may be adjusted.

FIGS. 11A-D illustrate the position of the ribbon 88 within the thermal printer 10, and to move the floating print head assembly 11 from a non-printing position to a printing position, the user simply moves the floating print head assembly downwardly (as shown by the arrow in **FIG. 11C**) until locked in the printing position. When the floating print head assembly 11 is lowered, the engaging end 55 of the latch 50 will be forced to engage within the pivot slot 54 to lock the assembly in the printing position. Typically, the engaging end 55 of the latch 50 is forced along the curvature of the pivot bracket 18, and once the engaging end enters the pivot slot 54, the spring biases the latch into engagement with the pivot bracket.

Once the floating print head assembly 11 is lowered to a printing position, the print head 14 is operational and may print onto a substrate. In the printing position, the print head 14 may align itself to apply uniform pressure across the substrate as the head bracket 16 and ball joint cap 58 rotate to adjust the roll of the print head. There may be a slight movement in the pitch and yaw of the print head 14 as the roll of the print head is adjusted or the print head moves over an uneven surface, although the roll of the print head will be predominately self-adjusted during printing. Thus, the print head 14 may align itself when settling in on the ribbon 88 and substrate. As mentioned previously, the latch 50 includes an engaging end 55 that engages a pivot slot 54, where the pivot slot defines a curvature that corresponds to the rotation about the ball joint shaft 56 about a y-axis (*i.e.*, roll). In addition, the pivot slot 54 is slightly larger in dimension than the engaging end 55 of the latch 50 (see **FIG. 5**) such that as the alignment mechanism 12 pivots about a y-axis, the head bracket 16 and print head support 20 may also pivot about the y-axis.

To create an image or similar configuration on a substrate, the substrate is preferably indexed prior to printing onto the substrate. Specifically, a ribbon 88 typically includes panels of colors arranged in series along the ribbon. Thus, once the substrate and print head 14 are in a starting printing position, the substrate will be moved by one or more platen rollers to generate a plurality of dot lines along the substrate. When additional colors are added to the substrate, print head 14 will be pivoted slightly off of the substrate about the pivot bracket shaft and axis A

such that the substrate may be indexed back to the starting printing position. The ribbon **88** will be indexed to a desired color and positioned adjacent to the substrate, and the printing process is then repeated with additional colors on the ribbon.

Typically, once the substrate and ribbon **88** are properly positioned, the print head **14** is lowered to the printing position and then cycled out of the printing position one time about the pivot bracket shaft to allow the print head to readjust or reset itself, although the print head could be cycled any number of times or none at all. For instance, a device, such as a cam **104**, is used in conjunction with a lever **96** to pivot the floating print head assembly **11** slightly upwards away from the ribbon **88** and substrate and then downwards about the pivot bracket shaft and axis **A** so that the print head **14** may settle in on the ribbon and substrate with the alignment mechanism **12**. Furthermore, the alignment mechanism **12** also facilitates movement of the print head **14** while printing, such that the print head may be continuously adjusting itself about the y-axis (*i.e.*, roll) to ensure that there is uniform pressure applied across the ribbon **88** and substrate.

There are many advantages associated with the present invention. For instance, the design of the floating print head assembly **11** with the head bracket **16** and pivot bracket **18** allows the print head **14** force to be disassociated with the latch **50** force. Thus, to change ribbon **88**, the latch button **48** only needs to be depressed to release the head bracket **16** from the pivot bracket **18**, while the relatively stronger print head **14** force remains engaged through the ball joint shaft **56** and pivot bracket through axis **B**.

Furthermore, the alignment mechanism **12** permits the print head **14** to self-adjust about a y-axis (*i.e.*, roll) to ensure that uniform pressure is applied across the substrate. Applying uniform pressure ensures that there will be uniform thermal transfer from the print head **14** to the ribbon **88** and substrate to produce a consistent quality image. Moreover, given the inherent tolerances associated with each of the components of the floating print head assembly **11**, the alignment mechanism **12** allows for tolerances without sacrificing print quality. Finally, the floating print head assembly **11** and alignment mechanism **12** may be easily assembled and disassembled.

Many modifications and other embodiments of the invention set forth herein will come to mind to one skilled in the art to which this invention pertains

having the benefit of the teachings presented in the foregoing descriptions and the associated drawings. Therefore, it is to be understood that the invention is not to be limited to the specific embodiments disclosed and that modifications and other embodiments are intended to be included within the scope of the appended claims. Although specific terms are employed herein, they are used in a generic and descriptive sense only and not for purposes of limitation.

THAT WHICH IS CLAIMED:

1. A print head assembly capable of applying substantially uniform pressure on a printing substrate comprising:
 - a print head; and
 - an alignment mechanism coupled to said print head, said print head capable of pivoting about said alignment mechanism about a plurality of axes to apply substantially uniform print pressure across the printing substrate.
2. The print head assembly according to Claim 1, wherein said print head is capable of pivoting about said alignment mechanism about at least two of a roll, a pitch, and a yaw axis.
3. The print head assembly according to Claim 1, wherein said alignment mechanism comprises a ball joint shaft and a ball joint cap, and wherein the cap is capable of pivoting about the ball joint shaft.
4. The print head assembly according to Claim 3, wherein the ball joint shaft comprises a ball and the ball joint cap comprises a socket, and wherein the socket is capable of receiving the ball.
5. The print head assembly according to Claim 1, further comprising a print head support coupled to said print head, wherein said alignment mechanism is positioned within said print head support.
6. A print head assembly capable of applying substantially uniform pressure on a printing substrate comprising:
 - a print head bracket;
 - a print head attached to said bracket such that said bracket is operable to carry said print head from an open position suspended above the printing substrate to a closed position adjacent to the printing substrate; and
 - an alignment mechanism disposed within said bracket, said print head bracket operable to pivot about said alignment mechanism about a first axis between the open position and the closed position, said print head bracket further operable to pivot about said alignment mechanism about a second axis such that

said print head is capable of pivoting about the second axis to apply substantially uniform print pressure across the printing substrate in the closed position.

7. The print head assembly according to Claim 6, wherein said alignment mechanism comprises a ball joint shaft and a ball joint cap, and wherein the cap is capable of pivoting about the ball joint shaft.

8. The print head assembly according to Claim 7, wherein the ball joint shaft comprises a ball and the ball joint cap comprises a socket, and wherein the socket is capable of receiving the ball.

9. The print head assembly according to Claim 6, wherein the second axis corresponds to a roll axis.

10. The print head assembly according to Claim 6, wherein the first axis corresponds to a pitch axis.

11. The print head assembly according to Claim 6, wherein said print head is capable of pivoting up to approximately 10 degrees about the second axis.

12. The print head assembly according to Claim 6, further comprising a pivot bracket, wherein said alignment mechanism is coupled to said pivot bracket along the first axis.

13. The print head assembly according to Claim 12, further comprising a latch operable to engage said pivot bracket in the closed position and to disengage a pivot slot defined in said pivot bracket.

14. The print head assembly according to Claim 13, wherein said latch is disposed within said print head bracket and is capable of pivoting about the second axis while engaging the pivot slot in the closed position.

15. A print head assembly capable of applying substantially uniform pressure on a printing substrate comprising:
a print head bracket;

a print head attached to said print head bracket such that said print head bracket is operable to carry said print head from an open position suspended above the printing substrate to a closed position adjacent to the printing substrate;

a pivot bracket coupled to said print head bracket, said print head bracket operable to pivot about said pivot bracket about a first axis between the open position and the closed position, said pivot bracket further operable to apply a print head force along the first axis; and

a latch operable to engage said pivot bracket and secure said print head bracket in the closed position, wherein a latch force required to release said print head bracket from the closed position is disassociated with the print head force.

16. The print head assembly according to Claim 15, further comprising an alignment mechanism disposed within said print head bracket, said print head bracket operable to pivot about said alignment mechanism about a second axis such that said print head is capable of pivoting about the second axis to apply substantially uniform print pressure across the printing substrate in the closed position.

17. The print head assembly according to Claim 16, wherein the second axis corresponds to a roll axis.

18. The print head assembly according to Claim 16, wherein the first axis corresponds to a pitch axis.

19. The print head assembly according to Claim 16, wherein said print head bracket is operable to pivot about said pivot bracket about a third axis.

20. The print head assembly according to Claim 19, wherein the third axis corresponds to a pitch axis.

21. A method for applying substantially uniform pressure on a printing substrate comprising:

providing a print head attached to a print head bracket;

pivoting the print head bracket about a first axis such that the print head bracket carries the print head from an open position suspended above the printing substrate to a closed position adjacent to the printing substrate; and

pivoting the print head bracket about a second axis such that the print head applies substantially uniform print pressure across the printing substrate in the closed position.

22. The method according to Claim 21, further comprising applying a print head force that is disassociated with a latch force required to release the print head bracket from the closed position.

23. The method according to Claim 21, wherein pivoting the print head bracket about the first axis comprises pivoting the print head bracket about a pitch axis.

24. The method according to Claim 21, wherein pivoting the print head bracket about the second axis comprises pivoting the print head bracket about a roll axis.

25. The method according to Claim 21, further comprising positioning a ribbon between the print head and the substrate.

26. The method according to Claim 25, further comprising printing onto the substrate by thermally transferring ink from the ribbon to the substrate.

27. The method according to Claim 26, wherein pivoting the print head bracket about the second axis comprises self-adjusting the print head about the second axis during said printing step.

28. An alignment assembly capable of aligning a print head on a printing substrate, the assembly comprising:
a shaft including a pivot member defined thereon; and
a cap defining a socket, wherein the socket is capable of receiving the pivot member and pivoting thereabout, and wherein said cap is coupled to the print head such that the print head is capable of pivoting about the pivot member.

29. The alignment assembly according to Claim 28, wherein said cap is capable of pivoting about the pivot member about at least one axis.

30. The alignment assembly according to Claim 29, wherein the at least one axis includes at least one of a roll, a pitch, and a yaw axis.

31. The alignment assembly according to Claim 28, wherein the cap is capable of pivoting about the pivot member about a roll axis when the print head is positioned adjacent to the substrate.

32. The alignment assembly according to Claim 28, wherein the pivot member comprises a ball.

33. The alignment assembly according to Claim 28, wherein the pivot member comprises a roller, and wherein the cap is capable of pivoting about a roll axis about the roller.

34. A method for applying substantially uniform pressure on a printing substrate comprising:

providing a print head coupled to an alignment mechanism; and

pivoting the print head about the alignment mechanism about a plurality of axes to apply substantially uniform print pressure across the printing substrate.

35. The method according to Claim 34, wherein pivoting comprises pivoting the print head about the alignment mechanism about at least two of a roll, a pitch, and a yaw axis.

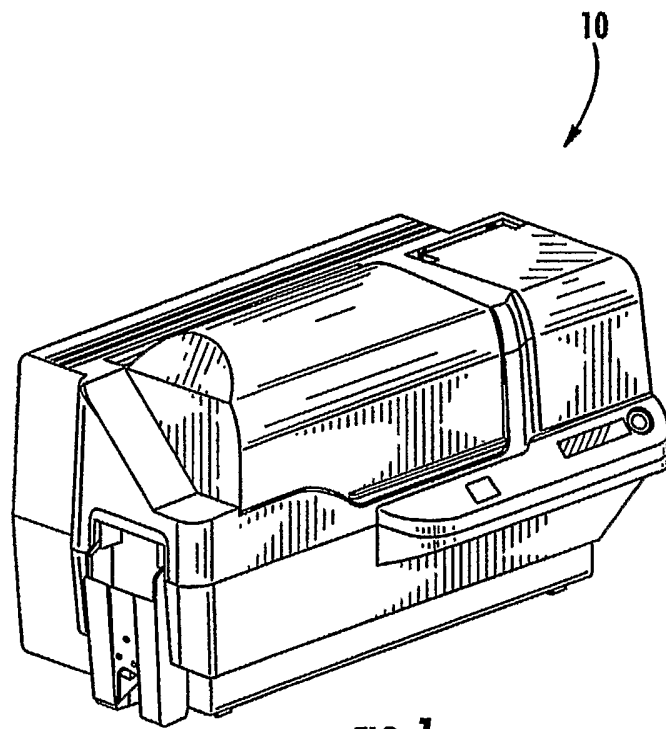

FIG. 1

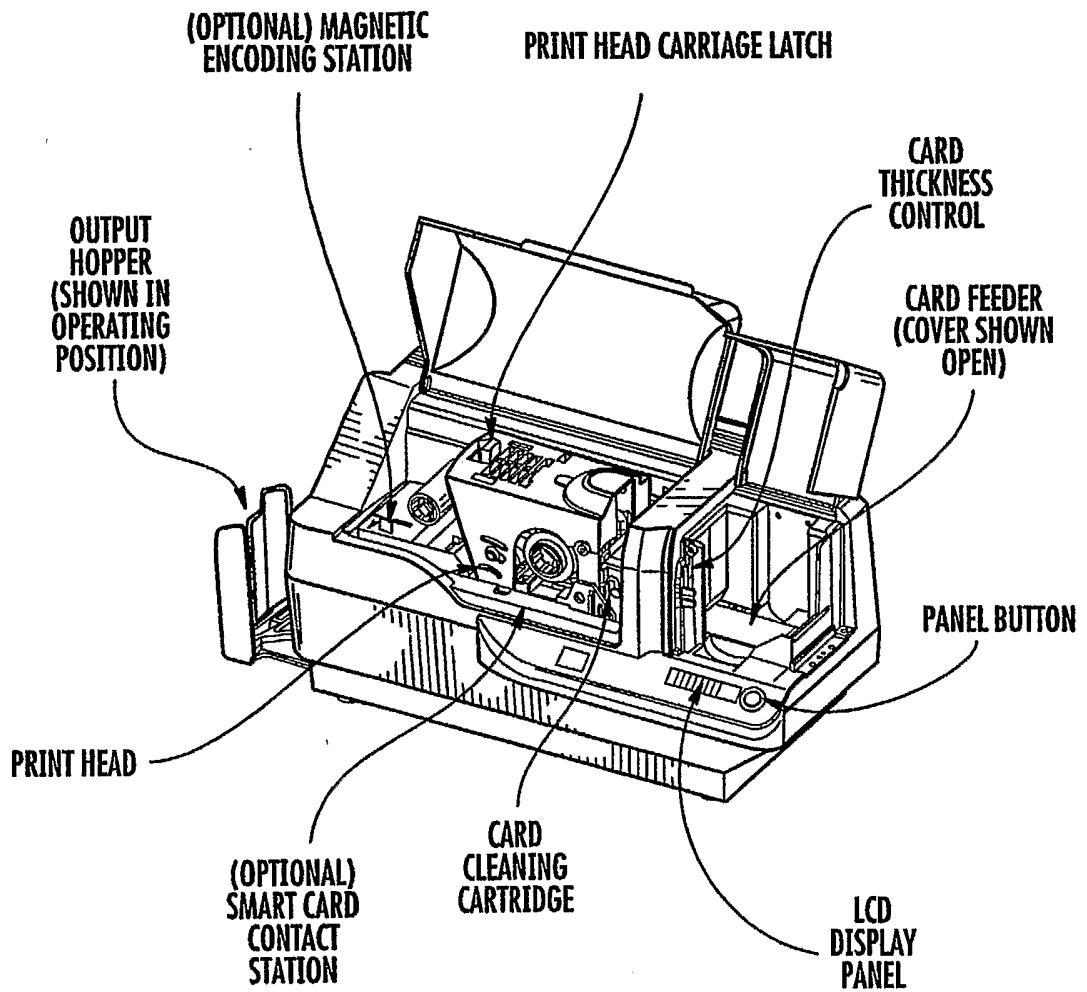
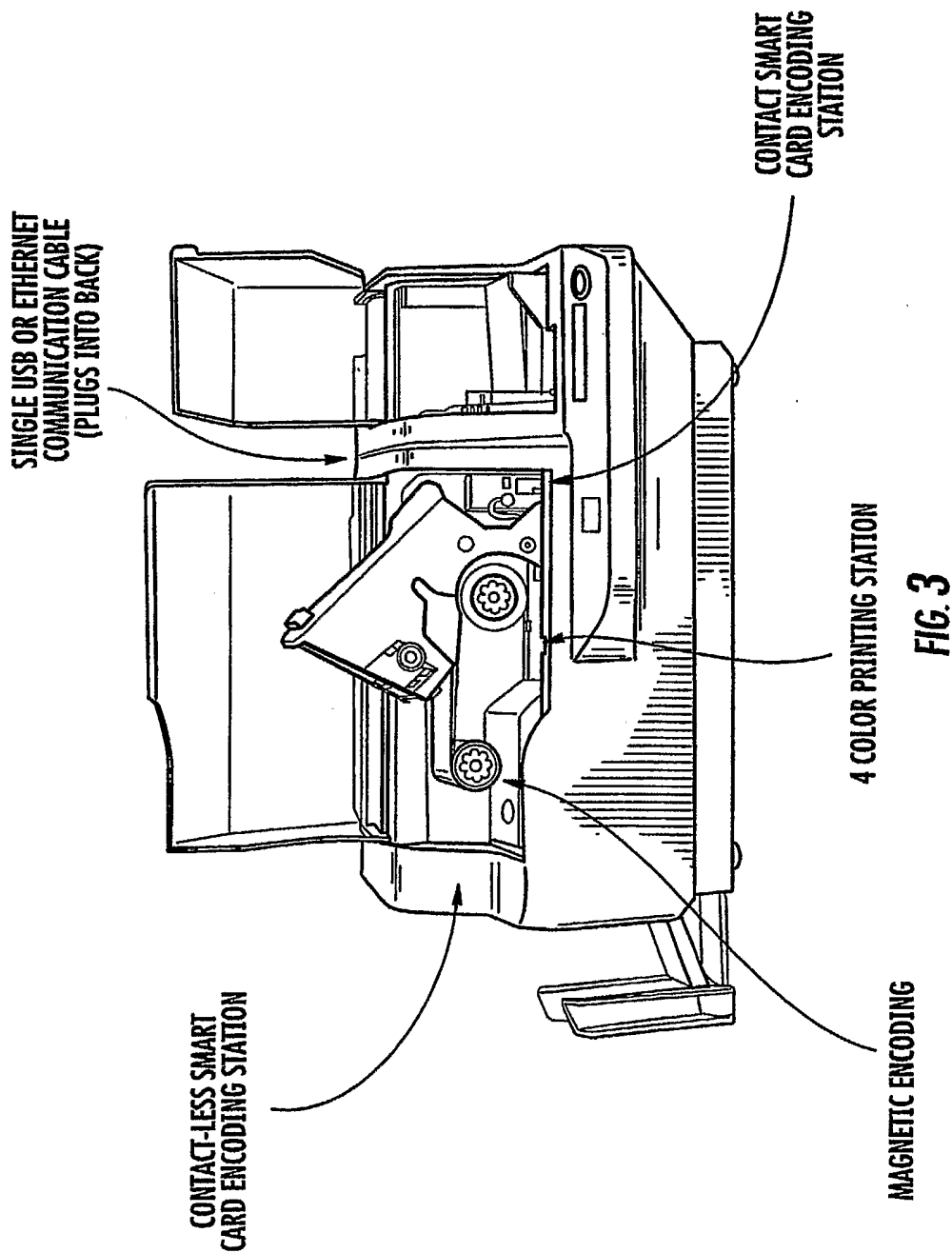

FIG. 2



4/12

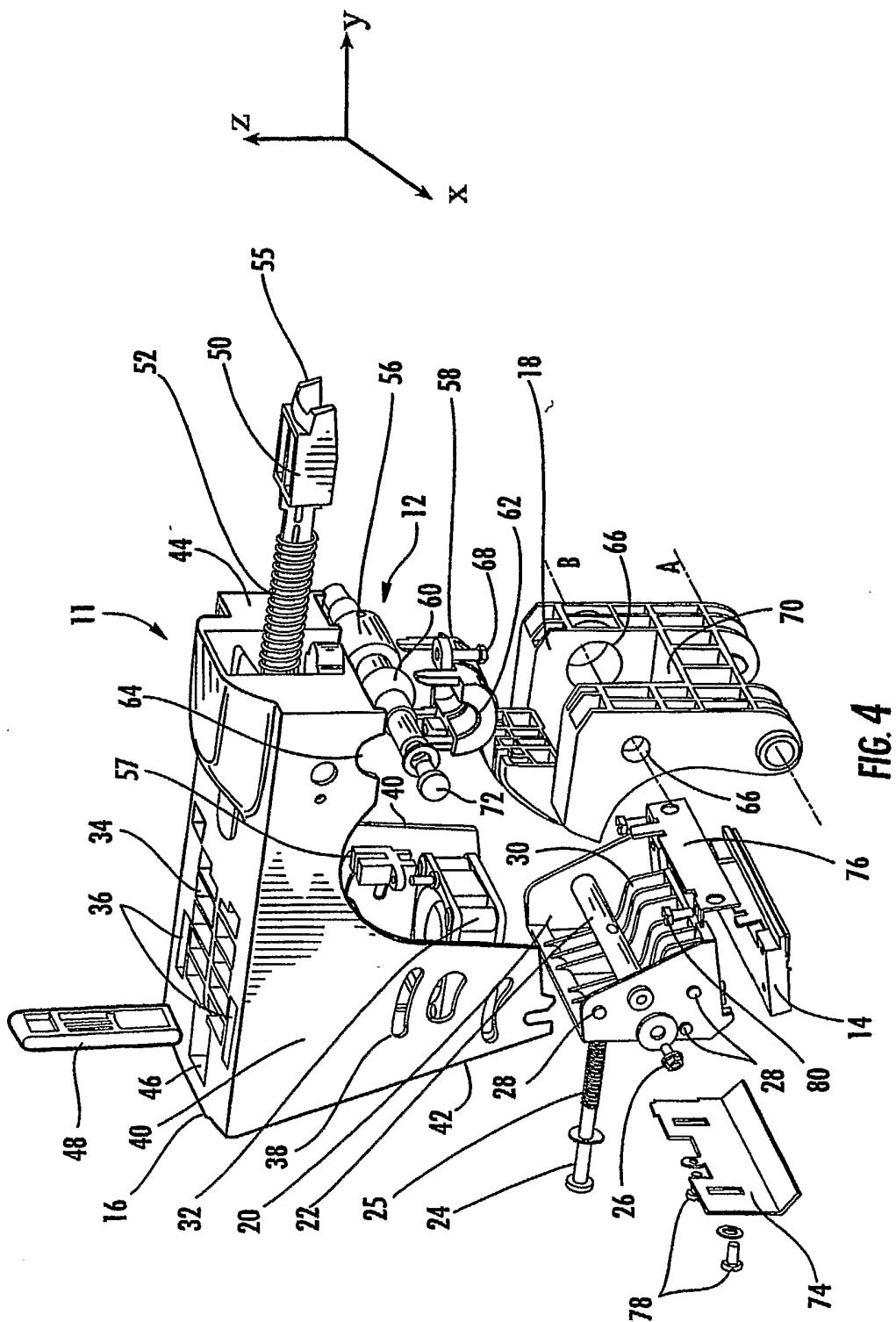

FIG. 4

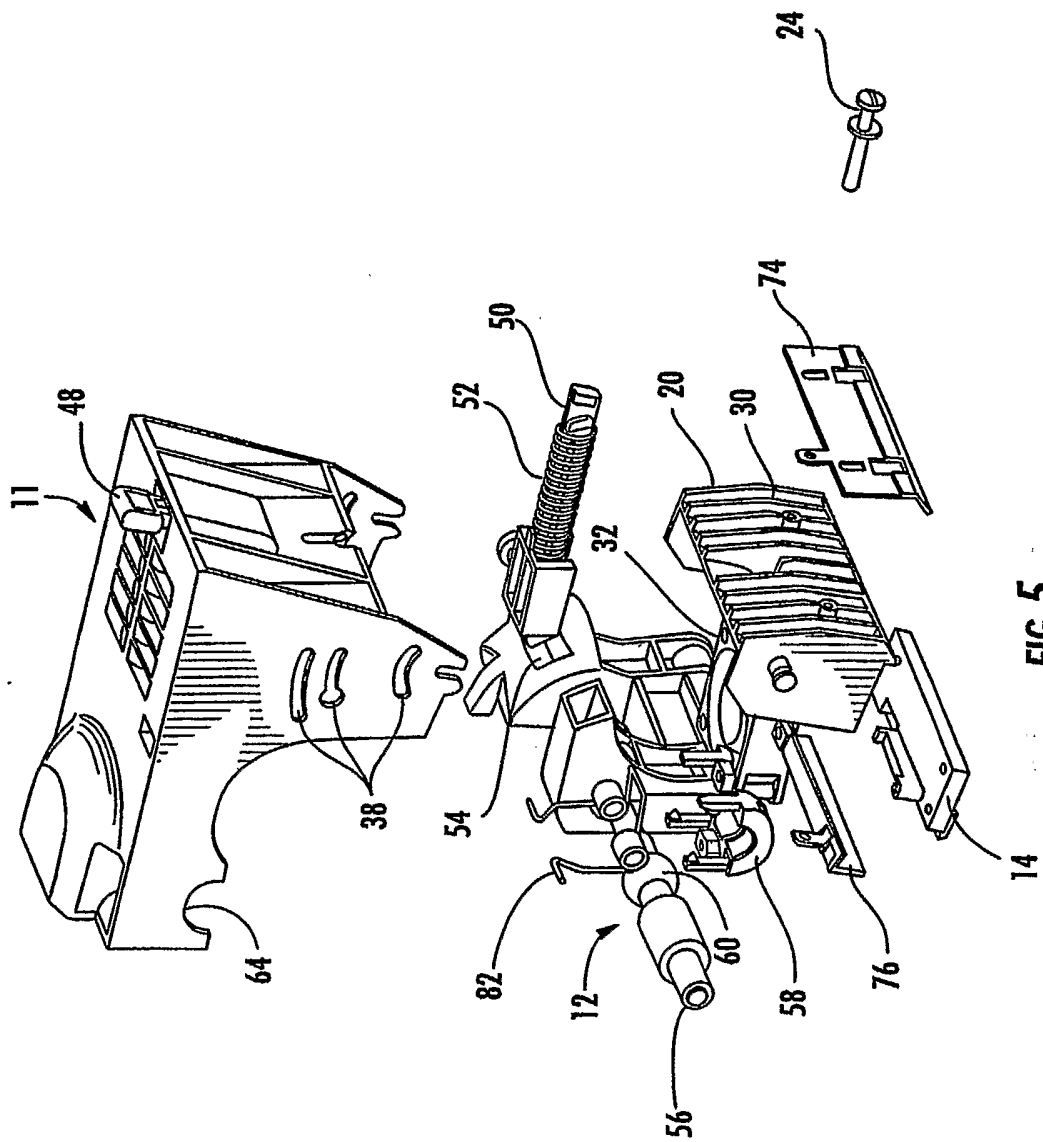
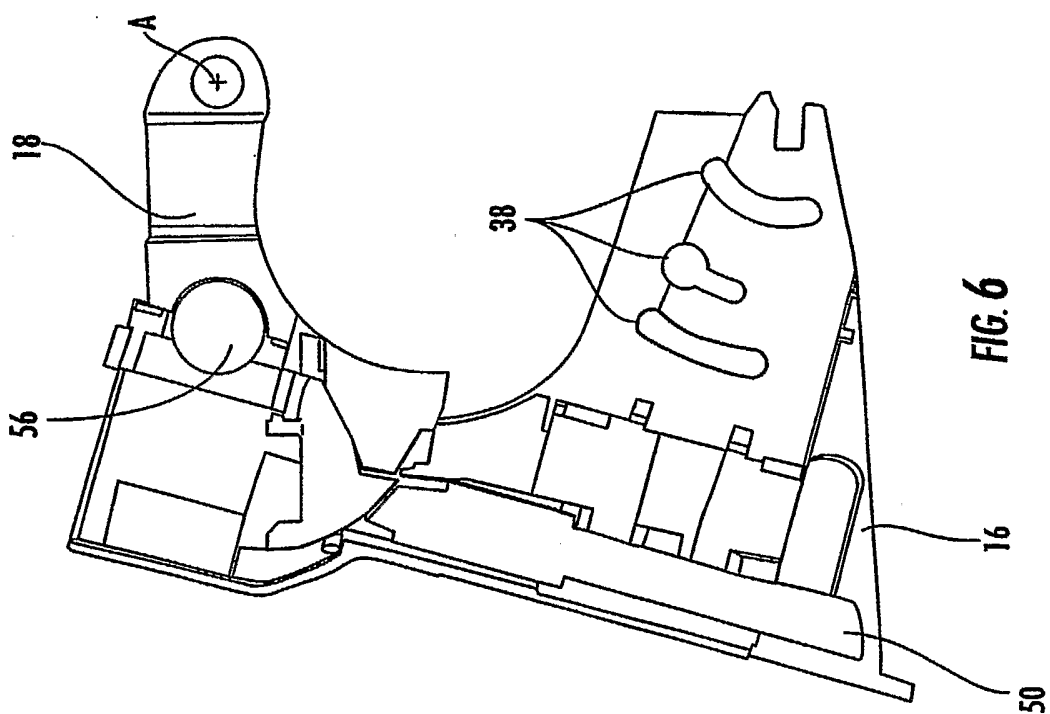

FIG. 5



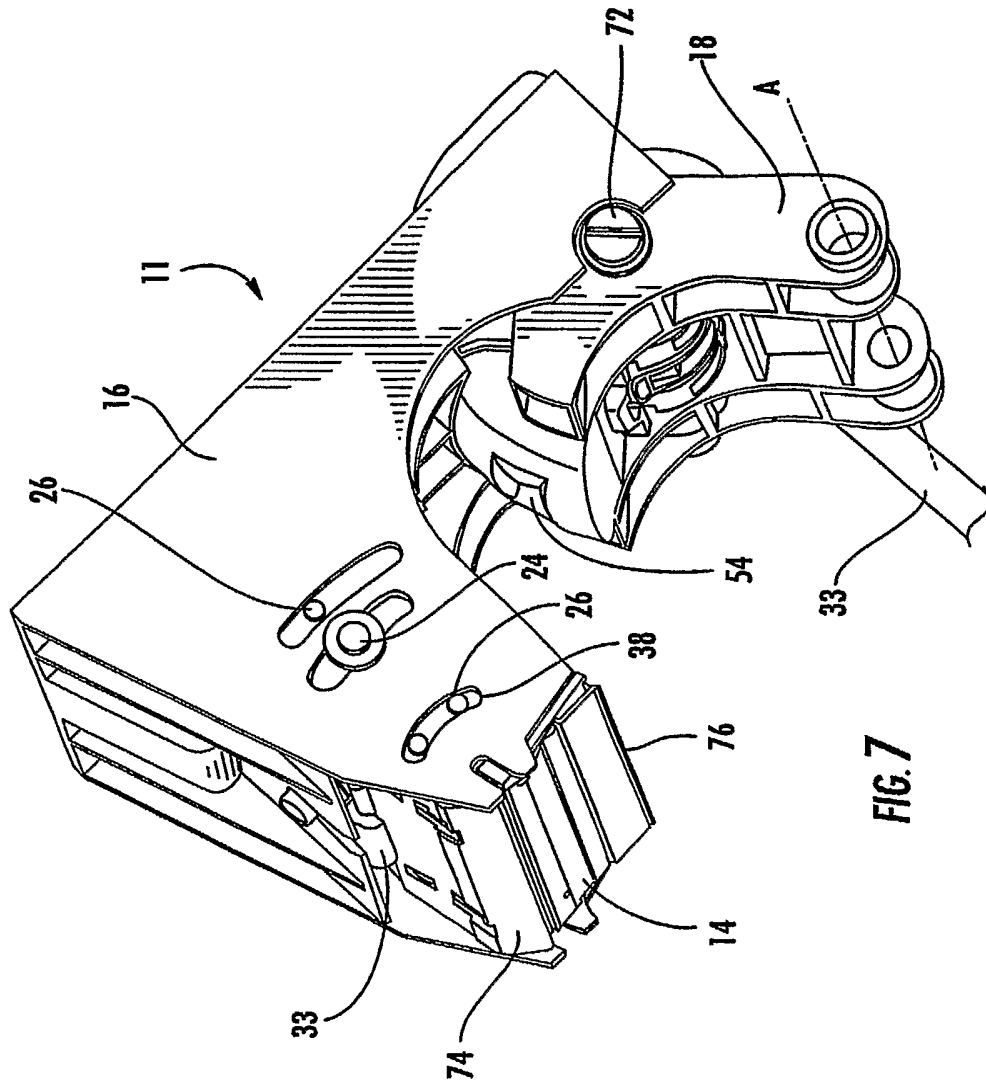
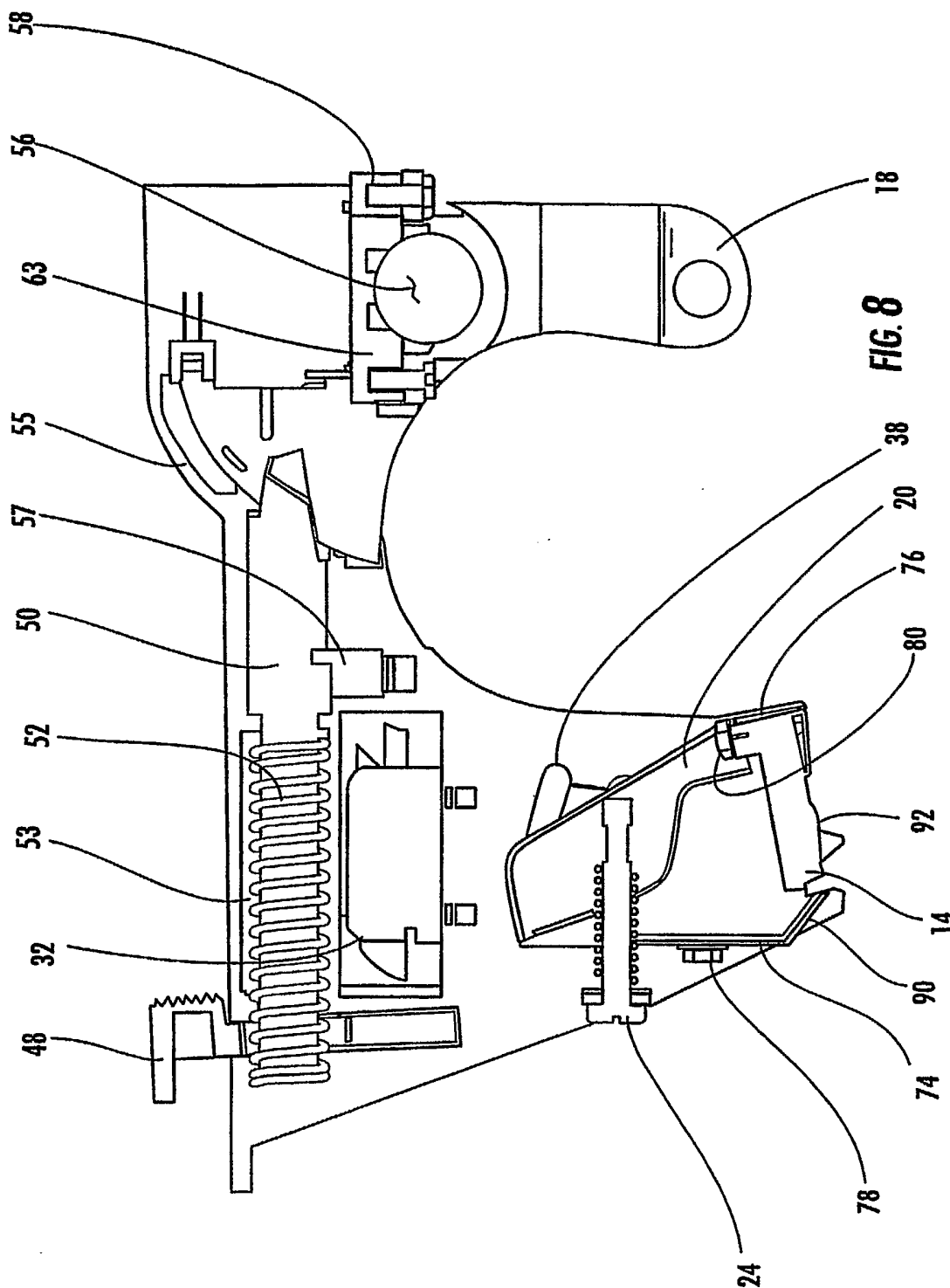

FIG. 7



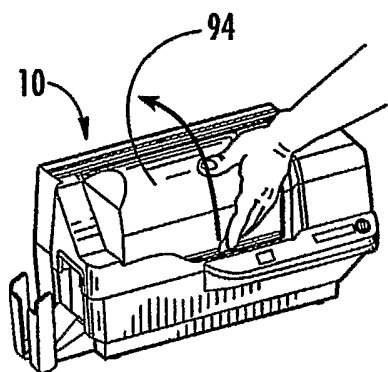

FIG. 9A

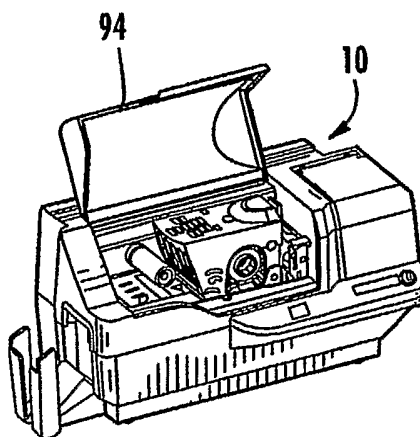

FIG. 9B

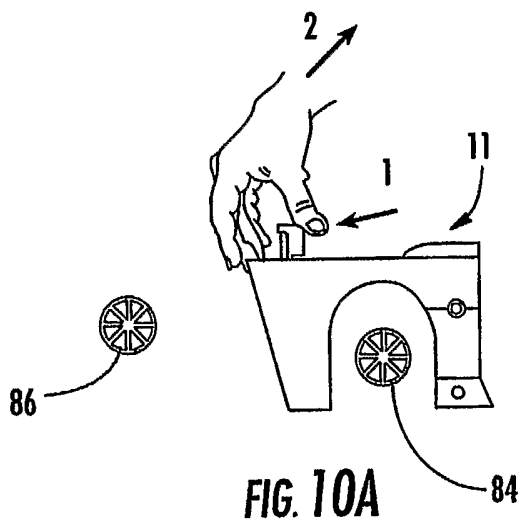

FIG. 10A

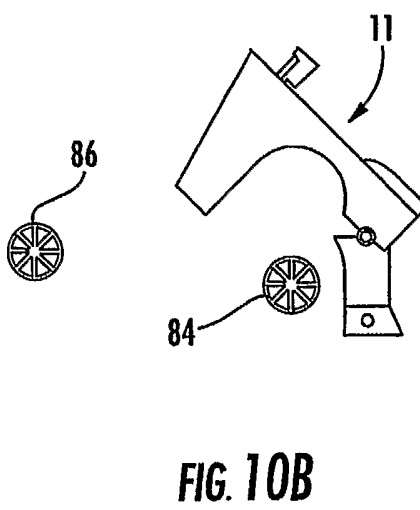

FIG. 10B

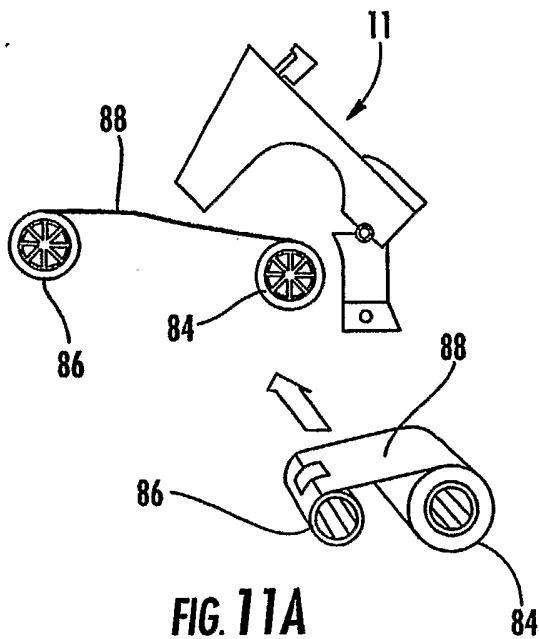

FIG. 11A

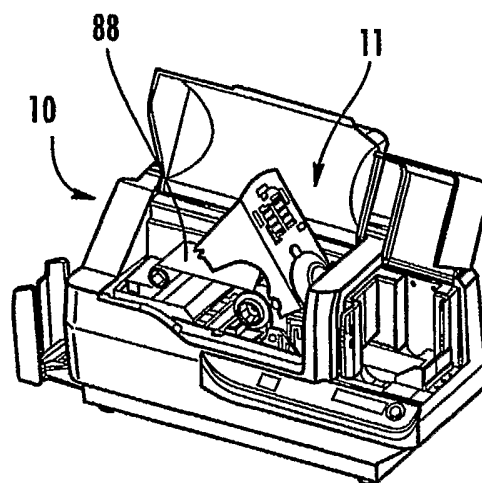

FIG. 11B

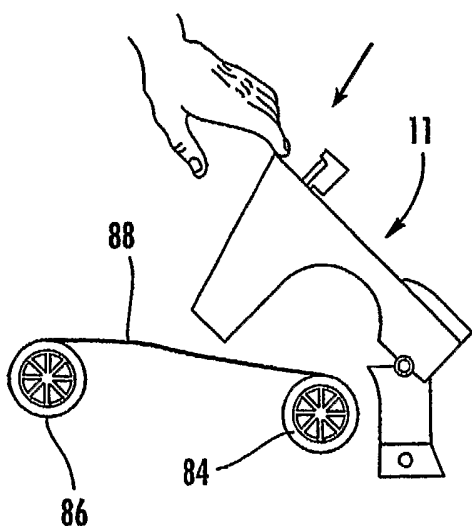

FIG. 11C

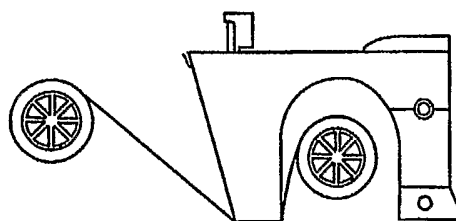

FIG. 11D

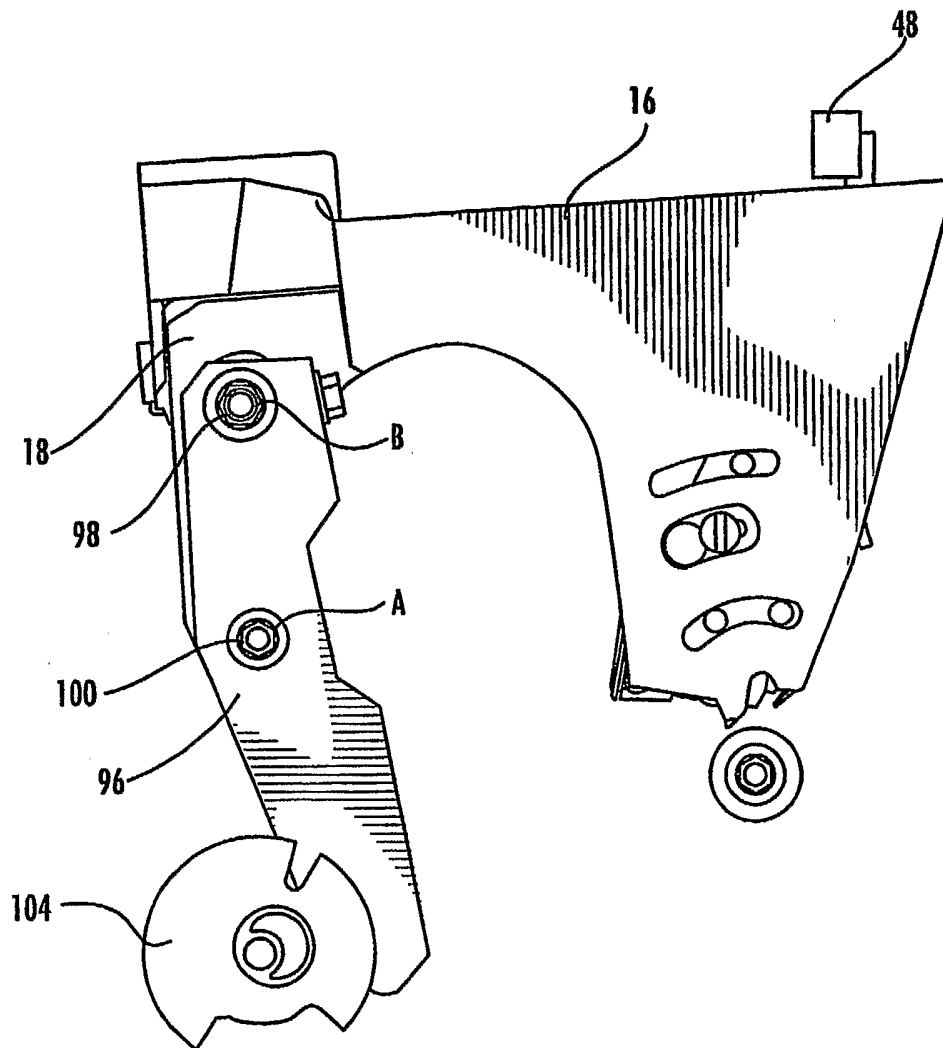

FIG. 12A

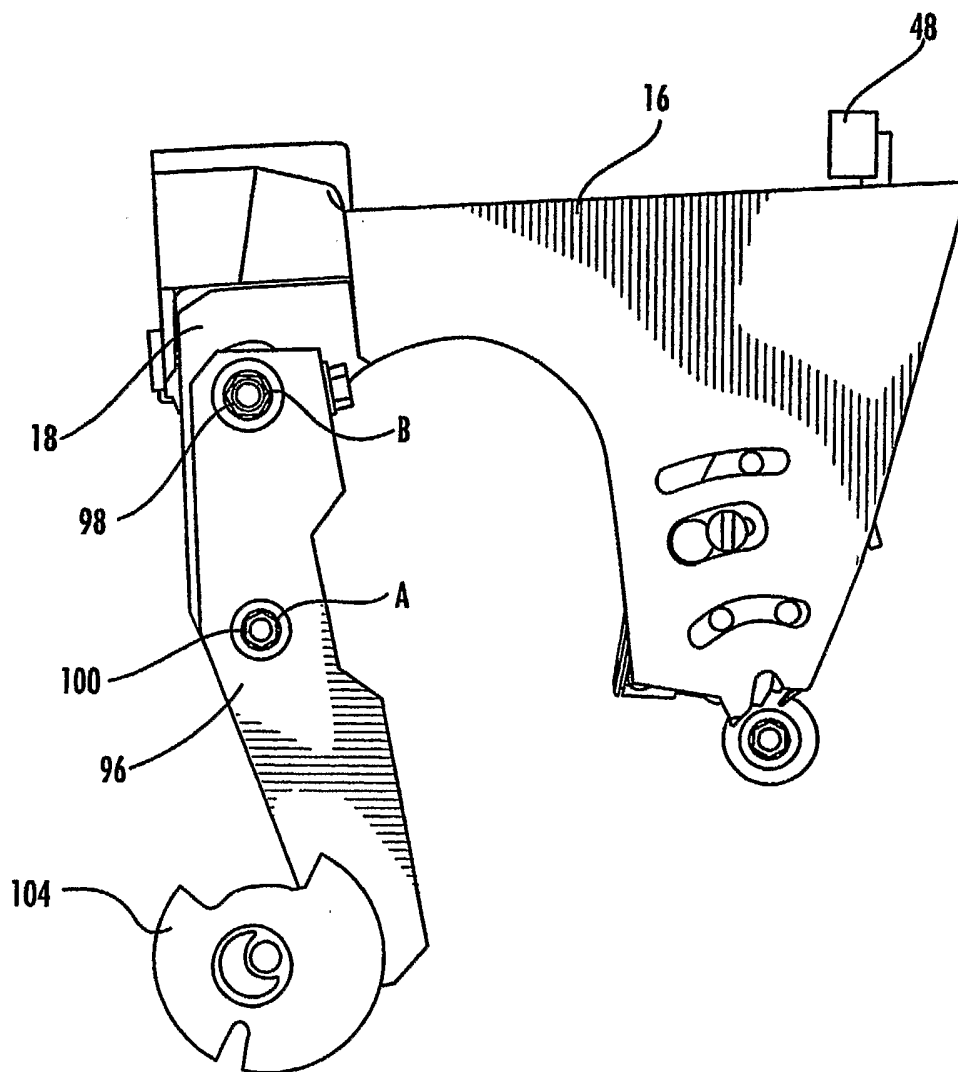

FIG. 12B