



(51) International Patent Classification:
H04W 16/00 (2009.01)

(21) International Application Number:
PCT/CN2009/072388

(22) International Filing Date:
22 June 2009 (22.06.2009)

(25) Filing Language: English

(26) Publication Language: English

(71) Applicant (for all designated States except US):
HUAWEI TECHNOLOGIES CO., LTD. [CN/CN];
Huawei Administration Building, Bantian, Longgang Dis-
trict, Shenzhen, Guangdong 518129 (CN).

(72) Inventors; and

(75) Inventors/Applicants (for US only): **ROBERT
SAFAVI, Anahid** [IR/SE]; Lillsj, Backen 12, S-
SE-16731 Bromma (SE). **WENNSTROM, Mattias** [SE/
SE]; S:t Johannesgatan 7C, S-753 11 Uppsala (SE). **LIU,
Jianghua** [CN/SE]; Haukadalsgatan 3 PO Box 54, S-
SE-164 94 Kista (SE).

(74) Agent: **BEIJING ZBSD PATENT & TRADEMARK
AGENT LTD.**; 501/B, Fortune Building, No.17 Daliushu
Road, Haidian District, Beijing 100081 (CN).

(81) Designated States (unless otherwise indicated, for every
kind of national protection available): AE, AG, AL, AM,
AO, AT, AU, AZ, BA, BB, BG, BH, BR, BW, BY, BZ,
CA, CH, CL, CN, CO, CR, CU, CZ, DE, DK, DM, DO,
DZ, EC, EE, EG, ES, FI, GB, GD, GE, GH, GM, GT,
HN, HR, HU, ID, IL, IN, IS, JP, KE, KG, KM, KN, KP,
KR, KZ, LA, LC, LK, LR, LS, LT, LU, LY, MA, MD,
ME, MG, MK, MN, MW, MX, MY, MZ, NA, NG, NI,
NO, NZ, OM, PE, PG, PH, PL, PT, RO, RS, RU, SC, SD,
SE, SG, SK, SL, SM, ST, SV, SY, TJ, TM, TN, TR, TT,
TZ, UA, UG, US, UZ, VC, VN, ZA, ZM, ZW.

(84) Designated States (unless otherwise indicated, for every
kind of regional protection available): ARIPO (BW, GH,
GM, KE, LS, MW, MZ, NA, SD, SL, SZ, TZ, UG, ZM,
ZW), Eurasian (AM, AZ, BY, KG, KZ, MD, RU, TJ,
TM), European (AT, BE, BG, CH, CY, CZ, DE, DK, EE,
ES, FI, FR, GB, GR, HR, HU, IE, IS, IT, LT, LU, LV,
MC, MK, MT, NL, NO, PL, PT, RO, SE, SI, SK, TR),
OAPI (BF, BJ, CF, CG, CI, CM, GA, GN, GQ, GW, ML,
MR, NE, SN, TD, TG).

Published:

— with international search report (Art. 21(3))

(54) Title: A METHOD AND SYSTEM FOR ASSIGNING REFERENCE SIGNALS IN MULTI ANTENNA CONTEXT

Fig. 2

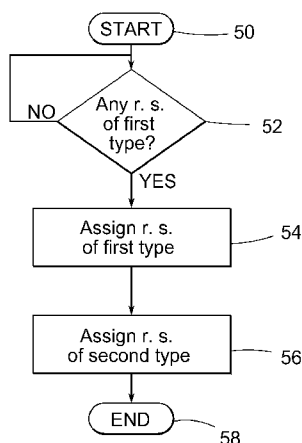

(57) Abstract: The present invention relates to a method of assigning reference signals to antennas and nodes in a wireless communication system comprising N number of transmitting nodes, wherein N is an integer, and N > 1. The transmitting nodes are transmitting reference signals in a first slot and a second slot within sub-frames, over the same bandwidth. Each node has at least one transmit antenna, wherein different nodes can have different number of transmit antennas. The reference signals are of two different types, a first type of reference signals used for demodulation, and a second type of reference signals used for measurements. The method comprises the steps: - to assign reference signals of the first type to a number of transmitting nodes with at least one transmit antenna in the first and second slot in a predefined bandwidth; and - to assign reference signals of the second type to at least one transmitting node with at least transmit antennas in at least one of the first and second slot in the predefined bandwidth.

WO 2010/148550 A1

A METHOD AND SYSTEM FOR ASSIGNING REFERENCE SIGNALS IN A MULTI ANTENNA CONTEXT

5 ***Field of the invention***

The present invention relates in a first aspect to a method of assigning reference signals to antennas and nodes in a wireless communication system.

According to a second aspect the present invention relates to a system operable to assign reference signals to antennas and nodes in a wireless
10 communication system.

According to a third aspect the present invention relates to at least one computer program product for assigning reference signals to antennas and nodes in a wireless communication system.

15 ***Background of the invention***

In a communication system, different categories of reference signals are used. One category of reference signals is used to estimate the channel which is needed to enable coherent demodulation of received signal containing both control and data information. Another category is used for channel quality measurements
20 and enabling scheduling.

For example, in the 3GPP LTE uplink, reference signals which are used for coherent demodulation are called demodulation reference signals (DRS) and reference signals which are used for channel quality measurements are called sounding reference signals (SRS).

Both SRS and DRS reference signals in LTE are decomposed of a cell specific base sequence with a predefined length and a corresponding cyclic shift in time domain. In LTE uplink, the base sequence is a Zadoff-Chu (ZC) or a Computer Generated (CG) sequence. The ZC sequence is used as the base sequence when the length of the base sequence is larger than 24 sub carriers.
25
30 Otherwise Computer Generated (CG) sequence is used. These two kinds of sequences have the advantage of having constant amplitude in time and frequency domain, which is desired for uplink reference signal (RS). Cyclic shift is a linear phase rotation in frequency domain applied to the base sequence. This linear phase shift in frequency domain is equivalent to a cyclic shift in time domain.

Different values of cyclic shifts are used to generate different orthogonal reference signals within one cell, from one base sequence.

In a multi user communication system, where several users with one transmit antenna transmit simultaneously in the same band, as in LTE uplink DRS
5 corresponding to multi-user MIMO or LTE uplink SRS, one cyclic shift is used to generate reference signal of each user. As the reference signals corresponding to users are orthogonal, cyclic shift value and reference signal can be used to separate different users at the receiver side.

In the LTE uplink, predefined and distinct symbols in the uplink sub-frame
10 are dedicated to transmit reference signals (RS), which is illustrated in Fig. 1. In the case of normal Cyclic Prefix (CP), DRS occupies the 4th symbol of each uplink slot and SRS is transmitted in the last symbol of some sub-frames which are configured by eNB. The transmission of DRS and SRS for each user equipment (UE) is independent. If one UE is scheduled in a number of resource blocks (RB)
15 in a subframe for transmitting the physical uplink shared channel (PUSCH), this UE will transmit DRS with length equal to scheduled bandwidth on the 4th symbol of the two slots of the subframe. The transmission bandwidth and sub-frames for SRS is configured by eNB. Even if a UE is not scheduled for data or control transmission, it can still transmit the SRS in the last symbol of the second slot in
20 the configured SRS transmission subframes.

For uplink DRS, multiple users use different cyclic shifts of the base sequence and transmit simultaneously only in the case of uplink multi-user MIMO transmission. Otherwise different users are separated by FDM and TDM. More precisely, when a single user is scheduled in a set of resource blocks and a
25 subframe in LTE uplink, as there is only one transmit antenna, only one DRS is needed and consequently only one cyclic shift is used and remaining cyclic shifts are leaved unused. For SRS on the other hand, multiple users are often scheduled in the same time frequency resource and are separated through different cyclic shifts of the base sequence.

30 For DRS in the case of MU-MIMO and SRS, cyclic shifts must be allocated to different users in such a way that the corresponding time shift between two users becomes larger than the channel delay spread. Otherwise, channels corresponding to different users will interfere with each other when performing

channel estimation at the receiver.. Therefore, not all available cyclic shifts of the base sequence can be used in practice.

Assume the case of an LTE system operating at 5 MHz bandwidth with a typical urban (TU) channel model with UE speed 3 km/h. This is a typical wireless communication channel. According to LTE Release 8, there are a total number of eight cyclic shifts available for SRS and DRS, i. e. up to eight users can be code multiplexed together. If consecutive cyclic shifts are allocated in frequency domain to different users, time shift between users is about 32 samples which is smaller than TU channel delay spread (39 samples). Therefore, in order to give enough protection against multi-path for each user at the receiver, at most every other cyclic shift must be allocated to each user which means that only four out of eight users can be code multiplexed together under the assumption of a TU channel.

LTE-Advanced is the evolution of LTE where the user equipment (UE) or a relay node (RN) has up to four transmit antennas and it is important to know the channel from all transmitter antennas to the receiver antennas since this information is used to select modulation and coding scheme for the data transmission and also to select precoding matrix to be used for the transmission. A precoding matrix, taken from a codebook of available precoding matrices, is selected by the receiver to match the channel and improve the quality of the transmission. The data and the DRS are precoded by the same precoding matrix whereas the SRS are not precoded. Hence, one SRS needs to be transmitted from each of the UEs transmission antennas, Let us consider SRS allocation for this case. When user equipments or relay nodes with multiple antennas are supported, a larger number of cyclic shifts must be allocated per UE or RN compared to LTE ,to distinguish each antenna and each user. In this case, the available eight sounding sequences are rapidly exhausted.

Therefore, the problem is how to estimate the channel from multiple transmit antennas for quality estimation and scheduling, i. e. how to sound the channels from UEs or RNs with multiple transmit antennas.

It is a further problem how to sound the channel from multiple users, were some users have multiple transmit antennas.

Further, it is a related problem how to keep the signalling overhead and reference signal overhead at a minimum.

It is also a related problem how to keep the interference level as low as possible.

The patent document WO 2009/017363 relates to a method and apparatus for multiplexing a reference signal from a User Equipment (UE), not
5 having any other signal transmission in the respective Transmission Time Interval (TTI) with a reference signal from another UE also having data transmission in the respective TTI, or with the control signal and reference signal from another UE transmitted in the respective TTI. The multiplexed reference signal from the UE not
10 having any other signal transmission in the respective TTI can serve as a sounding reference signal to enable the serving base station to apply link adaptation to a subsequent signal transmitted by the UE or it can serve as a reference signal conveying state information, such as resource request or service request. In this document, only the problem of limited number of SRS has been addressed. The other mentioned problems still remain.

15

Summary of the invention

The above mentioned problems are solved by a method of assigning reference signals to antennas and nodes in a wireless communication system according to Claim 1. The wireless communication system comprises N number of
20 transmitting nodes, wherein N is an integer, and $N \geq 1$. The transmitting nodes are transmitting reference signals in a first slot and a second slot within sub-frames, over the same bandwidth. Each node having at least one transmit antenna, wherein different nodes can have different number of transmit antennas. The reference signals are of two different types, a first type of reference signals used
25 for demodulation, and a second type of reference signals used for measurements. The method comprises the steps:

- to assign reference signals of the first type to a number of transmitting nodes with at least one transmit antenna in the first and second slot in a predefined bandwidth; and
- 30 - to assign reference signals of the second type to at least one transmitting node with at least two transmit antennas in at least one of the first and second slot in said predefined bandwidth.

An advantage with the method according to the present invention is that the overhead is the same as in LTE while assigning more sounding reference signals (SRS) to different users and different transmit antennas.

Another advantage is that the interference level between different
5 reference signals is reduced.

A still further advantage with the method according to the present invention is less signalling overhead for indicating cyclic shift value.

A further advantage in this context is achieved if the reference signals of the second type corresponding to at least one transmit antenna are assigned to
10 the first slot, and if the reference signals of the second type corresponding to the rest of the transmit antennas are assigned to the second slot. Hereby is achieved the further advantage that the transmit power per antenna gets higher given that the total transmit power of the user equipment is constant.

According to another embodiment it is an advantage if the reference
15 signals of the second type corresponding to at least one node are assigned to the first slot, and if the reference signals of the second type corresponding to the rest of the nodes are assigned to the second slot.

According to yet another embodiment it is an advantage if the reference signals of the second type corresponding to at least one first node are assigned to
20 the first slot, the reference signals of the second type corresponding to at least one second node are assigned to the second slot, and if the reference signals of the second type corresponding to at least one transmit antenna, for at least one third node, are assigned to the first slot, and if the reference signals of the second type
25 corresponding to the rest of the transmit antennas, for the at least one third node, are assigned to the second slot.

Furthermore, it is an advantage in this context if the reference signals of the second type assigned to the first slot are assigned a value of the cyclic shift different than the value of the cyclic shift assigned to the reference signals of the second type assigned to the second slot.

30 According to another embodiment it is an advantage if the reference signals of the second type assigned to the first slot are assigned a value of the cyclic shift equal to the value of the cyclic shift assigned to the reference signals of the second type assigned to the second slot.

A further advantage in this context is achieved if the antennas are virtual antennas, and if the method also comprises the step:

- to apply a precoding matrix/vector to each reference signal before transmission.

Furthermore, it is an advantage in this context if the reference signals of
5 the first type are demodulation reference signals (DRS).

A further advantage in this context is achieved if the reference signals of the second type are sounding reference signals (SRS).

Furthermore, it is an advantage in this context if the reference signals of the first type is precoded by a precoding matrix/vector whereas the reference
10 signals of the second type is not precoded by a precoding matrix/vector.

Furthermore, it is an advantage in this context if the nodes are user equipments (UE), relay nodes (RN), or mixture of UEs and RNs, in a wireless communication system such as LTE or LTE-advanced.

The above mentioned problems are also solved with a system operable to
15 assign reference signals to antennas and nodes in a wireless communication system according to Claim 12. The wireless communication system comprises N number of transmitting nodes, wherein N is an integer, and $N \geq 1$. The transmitting nodes are operable to transmit reference signals in a first slot and a second slot within sub-frames, over the same bandwidth. Each node has at least one transmit
20 antenna, wherein different nodes can have different number of transmit antennas. The reference signals are of two different types, a first type of reference signals used for demodulation, and a second type of reference signals used for measurements. The system comprises a control means operable to assign reference signals of the first type to a number of transmitting nodes with at least
25 one transmit antenna in the first slot, and in the second slot, in a predefined bandwidth. Furthermore, the control means is also operable to assign reference signals of the second type to at least one transmitting node with at least two transmit antennas in at least one of the first and second slot in said predefined bandwidth.

30 An advantage with the system according to the present invention is that the overhead is the same as in LTE while assigning more sounding reference signals (SRS) to different users and different transmit antennas.

Another advantage is that the interference level between different reference signals is reduced.

A still further advantage with the system according to the present invention is less signalling overhead for indicating cyclic shift value.

A further advantage in this context is achieved if the control means also is operable to assign the reference signals of the second type corresponding to at least one transmit antenna to the first slot, and to assign the reference signals of the second type corresponding to the rest of the transmit antennas to the second slot. Hereby is achieved the further advantage that the transmit power per antenna gets higher given that the total transmit power of the user equipment is constant.

According to another embodiment it is an advantage if the wireless communication system comprises P number of scheduled nodes, wherein P is an integer, and $P \geq 2$. The control means is also operable to assign the reference signals of the second type corresponding to at least one scheduled node to the first slot. The control means is also operable to assign the reference signals of the second type corresponding to the rest of the scheduled nodes to the second slot.

Furthermore, it is an advantage in this context if the control means also is operable to assign the reference signals of the second type corresponding to at least one first scheduled node to the first slot, to assign the reference signals of the second type corresponding to at least one second scheduled node to the second slot. The control means is also operable to assign reference signals of the second type corresponding to at least one transmit antenna, for at least one third scheduled node, to the first slot, and to assign the reference signals of the second type corresponding to the rest of the transmit antennas, for the at least one third scheduled node, to the second slot.

A further advantage in this context is achieved if the control means also is operable to assign the reference signals of the second type assigned to the first slot a value of the cyclic shift different than the value of the cyclic shift assigned to the reference signals of the second type assigned to the second slot.

According to another embodiment it is an advantage if the control means also is operable to assign a value of the cyclic shift to the reference signals of the second type equal to the value of the cyclic shift assigned to the reference signals of the second type assigned to the second slot.

Furthermore, it is an advantage in this context if the reference signals of the first type are demodulation reference signals (DRS).

A further advantage in this context is achieved if the reference signals of the second type are sounding reference signals (SRS).

Furthermore, it is an advantage in this context if the nodes are user equipments (UE), relay nodes (RN), or mixture of UEs and RNs, in a wireless communication system such as LTE or LTE-advanced.

The above mentioned problems are also solved with at least one computer program product according to Claim 21. The at least one computer program product is/are directly loadable into the internal memory of at least one digital computer, and comprises software code portions for performing the steps of the method according to the present invention when the at least one product is/are run on the at least one computer.

An advantage with this solution is that the overhead is the same as in LTE while assigning more sounding reference signals (SRS) to different users and different transmit antennas.

Another advantage is that the interference level between different reference signals is reduced.

A still further advantage with this solution is less signalling overhead for indicating cyclic shift value.

It will be noted that the term "comprises/comprising" as used in this description is intended to denote the presence of a given characteristic, step or component, without excluding the presence of one or more other characteristic, features, integers, components or groups thereof. Embodiments of the invention will now be described with a reference to the accompanying drawings, in which:

25

Brief description of the drawings

Fig. 1 shows an illustration of DRS and SRS position in the uplink sub frame of LTE;

Fig. 2 is a flow chart of a method of assigning reference signals to antennas and nodes in a wireless communication system according to the present invention;

Fig. 3 shows transmission of multiple SRS of one user equipment (UE) with multiple antennas over two slots;

Fig. 4 discloses schematically the relationship between virtual antennas and physical antennas;

Fig. 5 shows transmission of multiple SRS from different user equipments over two slots;

5 Fig. 6 shows a first alternative of the scenario where several user equipments with multiple transmit antennas must be supported;

Fig. 7 shows a second alternative of the scenario where several user equipments with multiple transmit antennas must be supported;

10 Fig. 8 shows mixed transmission of multiple SRS from different user equipments and different antennas;

Fig. 9 shows a scenario where only SRS is transmitted on the DRS symbol of each slot;

15 Fig. 10 discloses schematically different methods of assigning reference signals over time slots using code multiplexing for different nodes with multiple antennas;

Fig. 11 is a block diagram of a system operable to assign reference signals to antennas and nodes in a wireless communication system according to the present invention; and

20 Fig. 12 schematically shows a number of computer program products according to the present invention.

Detailed description of the preferred embodiments

In fig. 2 there is disclosed a flow chart of a method of assigning reference signals to antennas and nodes in a wireless communication system according to the present invention. The wireless communication system comprises N number of transmitting nodes, wherein N is an integer, and $N \geq 1$. The transmitting nodes are transmitting reference signals in a first slot and second slot within sub-frames, over the same bandwidth. Furthermore, each node has at least one transmit antenna, and different nodes can have different number of transmit antennas. The reference signals are of two different types, a first type of reference signals used for demodulation, and a second type of reference signals used for measurements. The method begins at block 50. The method continues, at block 52, to ask the question: Are there any reference signals of the first type? If the answer is negative, the method continues with performing the step 52 again. If, on the other

hand, the answer is affirmative, the method continues, at block 54, with the step: to assign reference signals of the first type to a number of transmitting nodes with at least one transmit antenna in the first and second slot in a predefined bandwidth. Thereafter, the method continues, at block 56, with the step: to assign reference
5 signals of the second type to at least one transmitting node with at least two transmit antennas in at least one of the first and second slot in said predefined bandwidth. The method is completed at block 58.

According to a preferred embodiment of the method according to the present invention, the reference signals of the second type corresponding to at
10 least one transmit antenna are assigned to the first slot, and the reference signals of the second type corresponding to the rest of the transmit antennas are assigned to the second slot.

According to another preferred embodiment, the reference signals of the second type corresponding to at least one node are assigned to the first slot, and
15 the reference signals of the second type corresponding to the rest of the nodes are assigned to the second slot.

According to a further preferred embodiment, the reference signals of the second type corresponding to at least one first node are assigned to the first slot, the reference signals of the second type corresponding to at least one second
20 node are assigned to the second slot, and the reference signals of the second type corresponding to at least one transmit antenna, for at least one third node, are assigned to the first slot, and the reference signals of the second type corresponding to the rest of the transmit antennas, for the at least one third node, are assigned to the second slot.

According to a first alternative of the method according to the present invention, the reference signals of the second type assigned to the first slot are assigned a value of the cyclic shift different than the value of the cyclic shift
25 assigned to the reference signals of the second type assigned to the second slot.

According to a second alternative, the reference signals of the second type assigned to the first slot are assigned a value of the cyclic shift equal to the
30 value of the cyclic shift assigned to the reference signals of the second type assigned to the second slot.

The assignment in the embodiments described here is performed in LTE or LTE-Advanced by control signalling in the physical layer, from the receiver to the

transmitter, using the physical downlink control channel (PDCCH) or in another channel at any layer above the physical layer.

Furthermore, if the transmit antennas are virtual antennas, the method also comprises the step:

- 5 - to apply a precoding matrix/vector to each demodulation reference signal before transmission.

According to a preferred embodiment of the method, the reference signals of the first type are demodulation reference signals (DRS) which are precoded by the precoding matrix/vector, and the reference signals of the second type are
10 sounding reference signals (SRS) which are not precoded by the precoding matrix/vector but transmitted per antenna.

Let us consider the case where there is only one node with multiple antennas to be sounded without loss of generality. In order to sound the channel of a node with multiple antennas, one SRS per antenna is needed. Multiple
15 antennas of one node to be sounded are divided into two antenna groups. Cyclic shifts in the SRS group of first slot are assigned as the SRS of the antennas in the first group and available cyclic shifts in the SRS group of second slot are used for SRS of antennas in the second group. Cyclic shifts for each group of antennas can be same or different. In this case, SRS of each antenna is transmitted once in the
20 sub-frame using SRS and DRS multiplexing. As SRS has lower performance requirement than DRS for demodulation, its transmission could be sparse compared to DRS. In LTE, SRS is only transmitted in the configured sub-frames by eNB to transmit SRS, and SRS only transmits in the last symbol of the configured sub-frame. According to this method, only part of antennas of a certain
25 node transmits SRS on the DRS symbol in one slot.

It should be noted that the term User Equipment (UE) will be used in the following detailed description and associated Figures, as an embodiment of a node but as is evident for those skilled in the art, a node in the present invention is not limited to user equipments, but also other types of nodes in a wireless communication
30 system such as a relay node are within the scope of the description and claims.

In fig. 3 there is disclosed transmission of multiple SRS of one UE with multiple antennas over two slots. Assume that the total available number of DRS cyclic shifts is eight, i. e. CS0-CS7 and a number of resource blocks (RB) are scheduled for UE A with a single antenna for Physical Uplink Shared Channel

(PUSCH) transmission. CS0 is used for DRS of this UE to demodulate PUSCH, and CS1-CS7 are not used. Unused cyclic shifts CS1-CS7 over two slots form two SRS groups respectively. UE B has two transmit antennas (antenna 1 and antenna 2) and two SRS are needed to sound corresponding channels.

5 Therefore, unused DRS cyclic shifts can be used for transmitting two SRS of UE B, i. e. the SRS of UE B is multiplexed with the DRS of UE A using CDM. SRS of antenna 1 and antenna 2 are transmitted in slot 1 and slot 2 respectively. The allocated cyclic shifts for the SRS of antenna 1 and antenna 2 could be same or different, e. g. CS4 is used for both antenna 1 and 2, or CS4 and CS5 are used
 10 for SRS of antenna 1 and 2 respectively. Interference level between SRS of UE B and DRS of UE A is reduced due to the fact that a better distribution of cyclic shifts over each slot is achieved. When the same cyclic shift is assigned to each group, signalling overhead to indicate the value of cyclic shifts is also reduced because only one cyclic shift needs to be indicated. Moreover, antenna 1 and antenna 2
 15 can send full power which was not the case if allocation were made over a single slot.

The “antenna” mentioned above could be a physical antenna or a virtual antenna. In fig. 4 there is schematically disclosed the relationship between virtual antennas and physical antennas. For each virtual antenna, the transmitted SRS is
 20 a precoded SRS. For instance, UE has four physical antennas, and the two precoding vectors are $[1 \ 1 \ 1 \ 1]^T$ and $[1 \ -1 \ 1 \ -1]^T$ or columns of any other orthogonal matrix. IN the first slot, the transmitted SRS is $[1 \ 1 \ 1 \ 1]^T * CS4$, and the SRS in the second slot is $[1 \ -1 \ 1 \ -1]^T * CS4$.

The two SRS resource groups over two slots can also be assigned in a
 25 user wise manner. In this case, multiple users are divided into two groups. Cyclic shift available over the first slot, or the first SRS group, are assigned to the first group of users and cyclic shifts available over the second slot are assigned to the second group of users. This case is based on the assumption that UE needs not transmit SRS two times in one sub-frame as described above, and therefore over
 30 each slot different user equipments can be supported. As in previous case, allocated cyclic shift values to user equipments over each slot could be same or different. It is worth mention that the precoded case also can be applied to the user wise separation scenario.

In fig. 5 there is disclosed transmission of multiple SRS from different user equipments over two slots. Assume that UE A uses only one cyclic shift CS0 as DRS to demodulate PUSCH and frequency hopping is implemented. For each SRS resource group, there is seven available cyclic shifts, i. e. CS1-CS7. UE B and UE C need to transmit SRS for sounding uplink channel. One SRS is needed for each UE. The SRS of UE B is transmitted in the first slot using the assigned cyclic shift (CS4) from the first SRS resource group, and UE C transmits SRS in the second slot using the assigned cyclic shift (CS4) from the second SRS resource group. The allocated SRS sequence for UE B and UE C could be same or different. The multiplexing between SRS and DRS is shown in fig. 5.

Now we shall describe a scenario where several user equipments with multiple transmit antennas must be supported. In this case, there are several user equipments to transmit SRS and each UE needs multiple SRSs. There are two alternative ways to assign the available cyclic shifts in the two SRS resource groups for each UE.

In fig. 6 there is disclosed the first alternative, or antenna wise separation. The multiple antennas of each UE are divided into two groups, and each group of antennas transmits SRS in one slot.

In fig. 7 there is disclosed the second alternative, or user wise separation. All the user equipments to transmit SRS are divided into two groups, and each group of user equipments transmits SRS in one slot.

The assumption on PUSCH transmission UE A is the same as in previous two examples. In this example, no hopping is assumed. There are two user equipments (UE B and UE C) to transmit SRS, and each UE has two transmit antennas.

Now we shall describe mixed allocation. In this approach, separation into two different groups to be allocated over two slots is done on both antenna separation basis and user separation basis. Each group contains SRS for some antennas and some users, and is allocated to a different slot as mentioned before.

IN fig. 8 there is disclosed mixed transmission of multiple SRS from different user equipments and different antennas. Let us consider the case where there is one UE (UE A) sending DRS and there are three different user equipments (UE B, UE C and UE D) each with two transmit antennas to be

sounded. UE B and UE C can be separated in a user wise manner, and different antennas corresponding to UE D is separated in an antenna wise manner.

eNB will schedule a number of RBs for DRS transmission and indicate the used cyclic shift for DRS. The scheduling information including RB allocation, index of cyclic shift for DRS, MCS, etc. is transmitted in PDCCH. After UE receives the scheduling information in PDCCH, it will transmit data and DRS in the certain allocated bandwidth. For SRS transmission, PDCCH can be used to indicate the allocated bandwidth and index of cyclic shift for SRS or this information can be configured by eNB through higher layer signalling, e. g. RRC signalling.

All the above given examples assume that there is one UE to be scheduled. In practice sometimes no UE is scheduled. For this case, all the cyclic shifts are available and can be used for transmitting SRS, i. e. only SRS is transmitted in the DRS symbol place of each slot, which is illustrated in fig. 9.

In fig. 10 there are schematically disclosed different methods of assigning reference signals over time slots using code multiplexing for different nodes with multiple antennas. Fig. 10 summarises examples and scenarios in one scheme by making abstraction on user wise separation or antenna wise separation. Different groups of sounding reference signals corresponding to users or antennas are shown by number 1, 2 and 3. As mentioned before, sounding is multiplexed with demodulation reference signal. Method C indicates the case where allocation of sounding reference signals is done over only one slot. In this method, group 1, 2 and 3 are code multiplexed together. Method B and method A are both describing the cases where allocation of sounding is made over two time slots. Method B indicates the case where allocation is made over two slots with group 1 and 2 using different cyclic shifts. In this case, cyclic shifts are distributed over two slots providing a better separation between them and less interference comparing to the first case. Method A describes the case of allocation over two slots where only cyclic shift is used for different allocation. As mentioned before, with this solution we guarantee less interference and less signalling overhead.

In fig. 11 there is disclosed a block diagram of a system 10 operable to assign reference signals to antennas and nodes in a wireless communication system 12 according to the present invention. In the general case, the wireless communication system 12 comprises N number of transmitting nodes $14_1, \dots, 14_N$, wherein N is an integer, and $N \geq 1$. In fig. 11 there are only disclosed two

transmitting nodes 14_1 , 14_2 for the sake of simplicity. The transmitting nodes are operable to transmit reference signals in a first slot and a second slot within sub-frames, over the same bandwidth. Each transmitting node has at least one transmit antenna 16_{11} , ..., 16_{N_1} , 16_{N_2} , wherein different nodes can have different number of transmit antennas. In the system 10 disclosed in fig. 11, the transmitting node 14_1 has two transmit antennas 16_{11} and 16_{12} , and the transmitting node 14_2 has only one transmit antenna 16_{21} . It is pointed out that the reference signals are of two different types, a first type of reference signals used for demodulation, and a second type of reference signals used for measurements. As is apparent in fig. 11, the system 10 also comprises a control means 18 connected to the wireless communication system 12, and operable to assign reference signals of the first type to a number of transmitting nodes 14_x , in fig. 11, 14_2 with at least one transmit antenna 16_{21} in the first slot and in the second slot, in a predefined bandwidth. The control means 18 is also operable to assign reference signals of the second type to at least one transmitting node 14_y , in fig. 11, 14_1 , with at least two transmit antennas 16_{11} and 16_{12} in at least one of the first and second slot in the predefined bandwidth.

According to a preferred embodiment of the system 10 according to the present invention, the control means 18 is also operable to assign the reference signals of the second type corresponding to at least one transmit antenna 16_{11} to the first slot, and to assign the reference signals of the second type corresponding to the rest of the transmit antennas 16_{12} to the second slot.

According to another embodiment, the wireless communication system 12 comprises, in the general case, P number of scheduled user equipments 20_1 , ..., 20_P , wherein P is an integer, and $P \geq 2$. In fig. 11, there are only disclosed two scheduled user equipments 20_1 and 20_2 . The control means 18 is also operable to assign reference signals of the second type corresponding to at least one scheduled user equipment 20_1 to the first slot. The control means 18 is also operable to assign the reference signals of the second type corresponding to the rest of the scheduled user equipments 20_2 to the second slot.

According to another embodiment of the system 10, the control means 18 is also operable to assign the reference signals of the second type corresponding to at least one first scheduled user equipment to the first slot, to assign reference signals of the second type corresponding to at least one second scheduled user

equipment to the second slot. The control means 18 is also operable to assign the reference signals of the second type corresponding to at least one transmit antenna, for at least one third scheduled user equipment, to the first slot, and to assign the reference signals of the second type corresponding to the rest of the
5 transmit antennas, for the at least one third scheduled user equipment, to the second slot.

Furthermore, according to another alternative, the control means 18 is also operable to assign the reference signals of the second type assigned to the first slot a value of the cyclic shift different than the value of the cyclic shift
10 assigned to the reference signals of the second type assigned to the second slot.

According to another alternative, the control means 18 is also operable to assign a value of the cyclic shift to the reference signals of the second type equal to the value of the cyclic shift assigned to the reference signals of the second type assigned to the second slot.

15 Furthermore, the reference signals of the first type are demodulation reference signals (DRS), and the reference signals of the second type are sounding reference signals (SRS).

In fig. 12, some computer program products $102_1, \dots, 102_n$ according to the present invention are schematically shown. In fig. 12, n different digital
20 computers $100_1, \dots, 100_n$ are shown, wherein n is an integer. In fig. 12, n different computer program products $102_1, \dots, 102_n$ are shown, here shown in the form of CD discs. The different computer program products $102_1, \dots, 102_n$ are directly loadable into the internal memory of the n different computers $100_1, \dots, 100_n$. Each computer program product $102_1, \dots, 102_n$ comprises software code portions for
25 performing all the steps according to fig. 2, when the product/ products $102_1, \dots, 102_n$ is/are run on the computers $100_1, \dots, 100_n$. The computer program products $102_1, \dots, 102_n$ may, for instance, be in the form of diskettes, RAM discs, magnetic tapes, magneto-optical discs or some other suitable products.

The invention is not limited to the described embodiments. It will be
30 evident for those skilled in the art that many different modifications are feasible within the scope of the following Claims.

CLAIMS

1. A method of assigning reference signals to antennas and nodes in a wireless communication system comprising N number of transmitting nodes, wherein N is an integer, and $N \geq 1$, said transmitting nodes transmitting reference signals in a first slot and a second slot within sub-frames, over the same bandwidth, wherein each node having at least one transmit antenna, wherein different nodes can have different number of transmit antennas, **characterized** in that said reference signals are of two different types, a first type of reference signals used for demodulation, and a second type of reference signals used for measurements, said method comprises the steps:
- to assign reference signals of said first type to a number of transmitting nodes with at least one transmit antenna in said first and second slot in a predefined bandwidth; and
 - to assign reference signals of said second type to at least one transmitting node with at least two transmit antennas in at least one of said first and second slot in said predefined bandwidth.
2. A method of assigning reference signals to antennas and nodes in a wireless communication system according to Claim 1, **characterized** in that said reference signals of said second type corresponding to at least one transmit antenna are assigned to said first slot, and in that said reference signals of said second type corresponding to the rest of said transmit antennas are assigned to said second slot.
3. A method of assigning reference signals to antennas and nodes in a wireless communication system according to Claim 1, **characterized** in that said reference signals of said second type corresponding to at least one node are assigned to said first slot, and in that said reference signals of said second type corresponding to the rest of said nodes are assigned to said second slot.
4. A method of assigning reference signals to antennas and nodes in a wireless communication system according to Claim 1, **characterized** in that reference signals of said second type corresponding to at least one first nodes are

assigned to said first slot, said reference signals of said second type corresponding to at least one second node are assigned to said second slot, and in that said reference signals of said second type corresponding to at least one transmit antenna, for at least one third node, are assigned to said first slot, and in
5 that said reference signals of said second type corresponding to the rest of said transmit antennas, for said at least one third node, are assigned to said second slot.

5. A method of assigning reference signals to antennas and nodes in a
10 wireless communication system according to any one of Claims 1-4,
characterized in that said reference signals of said second type assigned to said first slot are assigned a value of the cyclic shift different than the value of the cyclic shift assigned to said reference signals of said second type assigned to said second slot.

15
6. A method of assigning reference signals to antennas and nodes in a wireless communication system according to any one of Claims 1-4,
characterized in that said reference signals of said second type assigned to said first slot are assigned a value of the cyclic shift equal to the value of the cyclic shift
20 assigned to said reference signals of said second type assigned to said second slot.

7. A method of assigning reference signals to antennas and nodes in a wireless communication system according to any one of Claims 1-6,
25 **characterized** in that said antennas are virtual antennas, and in that said method also comprises the step:
- to apply a precoding matrix/vector to each reference signal before transmission.

8. A method of assigning reference signals to antennas and nodes in a
30 wireless communication system according to any one of Claims 1-7,
characterized in that said reference signals of said first type are demodulation reference signals (DRS).

9. A method of assigning reference signals to antennas and nodes in a wireless communication system according to any one of Claims 1-8, **characterized** in that said reference signals of said second type are sounding reference signals (SRS).

5

10. A method of assigning reference signals to antennas and nodes in a wireless communication system according to any one of Claims 1-9, **characterized** in that said nodes are user equipments (UE) , relay nodes (RN) or a mixture of user equipments and relay nodes.

10

11. A method of assigning reference signals to antennas and nodes in a wireless communication system according to Claim 8 and 9 **characterized** in that said reference signals of first type is precoded by a precoding matrix/vector whereas said reference signal of second type is not precoded by a precoding
15 matrix/vector.

15

12. A system (10) operable to assign reference signals to antennas and nodes in a wireless communication system (12) comprising N number of transmitting nodes ($14_1, \dots, 14_N$), wherein N is an integer, and $N \geq 1$, said transmitting nodes
20 ($14_1, \dots, 14_N$) are operable to transmit reference signals in a first and a second slot within sub-frames, over the same bandwidth, wherein each node having at least one transmit antenna ($16_{11}, 16_{12}, 16_{21}, \dots$), wherein different nodes can have different number of transmit antennas, **characterized** in that said reference signals are of two different types, a first type of reference signals used for
25 demodulation, and a second type of reference signals used for measurements, and in that said system (10) comprises a control means (18) operable to assign reference signals of said first type to a number of transmitting nodes (14_x) with at least one transmit antenna (16_1) in said first slot, and in said second slot, in a predefined bandwidth, and in that said control means (18) also is operable to
30 assign reference signals of said second type to at least one transmitting node (14_y) with at least two transmit antennas ($16_{y1}, 16_{y2}$) in at least one of said first and second slot in said predefined bandwidth.

30

13. A system (10) operable to assign reference signals to antennas and nodes in a wireless communication system (12) according to Claim 12, **characterized** in that said control means (18) also is operable to assign said reference signals of said second type corresponding to at least one transmit antenna (16₁₁) to said first slot, and to assign said reference signals of said second type corresponding to the rest of said transmit antennas (16₁₂) to said second slot.

14. A system (10) operable to assign reference signals to antennas and nodes in a wireless communication system (12) according to Claim 12, **characterized** in that said wireless communication system (12) comprises P number of scheduled nodes (20₁, ..., 20_P), wherein P is an integer, and $P \geq 2$, and in that said control means (18) also is operable to assign said reference signals of said second type corresponding to at least one scheduled node (20₁) to said first slot, and in that said control means (18) also is operable to assign said reference signals of said second type corresponding to the rest of said scheduled nodes (20₂, ..., 20_P) to said second slot.

15. A system (10) operable to assign reference signals to antennas and nodes in a wireless communication system (12) according to Claim 14, **characterized** in that said control means (18) also is operable to assign said reference signals of said second type corresponding to at least one first scheduled node (20₁) to said first slot, to assign said reference signals of said second type corresponding to at least one second scheduled node (20₂) to said second slot, and in that said control means (18) also is operable to assign said reference signals of said second type corresponding to at least one transmit antenna (16₁₁), for at least one third scheduled node (20₃), to said first slot, and to assign said reference signals of said second type corresponding to the rest of said transmit antennas (16₁₂), for said at least one third scheduled node (20₃), to said second slot.

16. A system (10) operable to assign reference signals to antennas and nodes in a wireless communication system (12) according to any one of Claims 12-15, **characterized** in that said control means (18) also is operable to assign said reference signals of said second type assigned to said first slot a value of the

cyclic shift different than the value of the cyclic shift assigned to said reference signals of said second type assigned to said second slot.

17. A system (10) operable to assign reference signals to antennas and nodes
5 in a wireless communication system (12) according to any one of Claims 12-15,
characterized in that said control means (18) also is operable to assign a value of
the cyclic shift to said reference signals of said second type equal to the value of
the cyclic shift assigned to said reference signals of said second type assigned to
said second slot.

10

18. A system (10) operable to assign reference signals to antennas and nodes
in a wireless communication system (12) according to any one of Claims 12-17,
characterized in that said reference signals of said first type are demodulation
reference signals (DRS).

15

19. A system (10) operable to assign reference signals to antennas and nodes
in a wireless communication system (12) according to any one of Claims 12-18,
characterized in that said reference signals of said second type are sounding
reference signals (SRS).

20

20. A system (10) operable to assign reference signals to antennas and nodes
in a wireless communication system (12) according to any one of Claims 12-19,
characterized in that said nodes are user equipments (UE) or relay nodes (RN).

25 21. At least one computer program product ($102_1, \dots, 102_n$) directly loadable
into the internal memory of at least one digital computer ($100_1, \dots, 100_n$),
comprising software code portions for performing the steps of Claim 1 when said
at least one product ($102_1, \dots, 102_n$) is/are run on said at least one computer
($100_1, \dots, 100_n$).

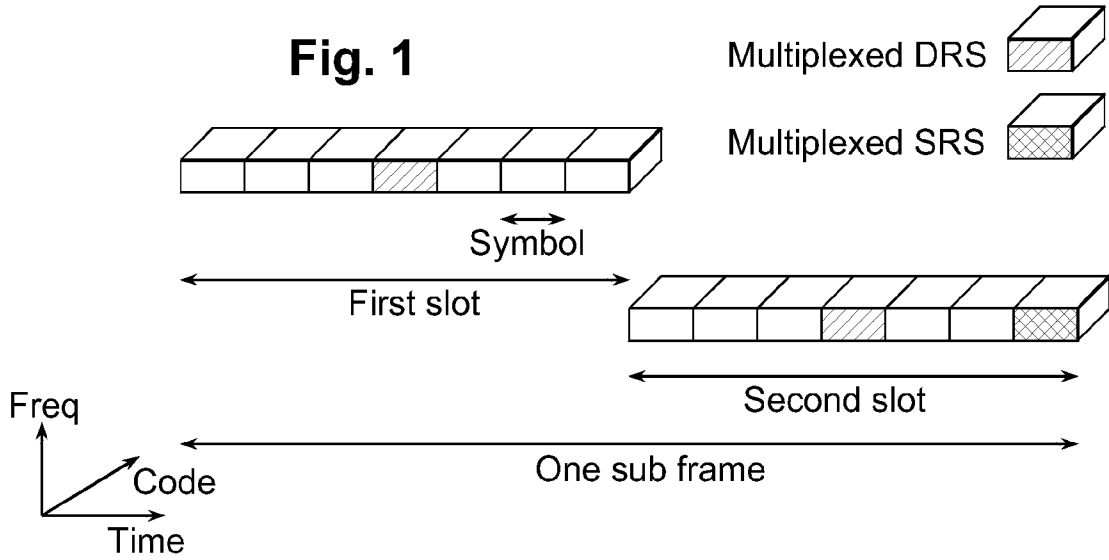

Fig. 2

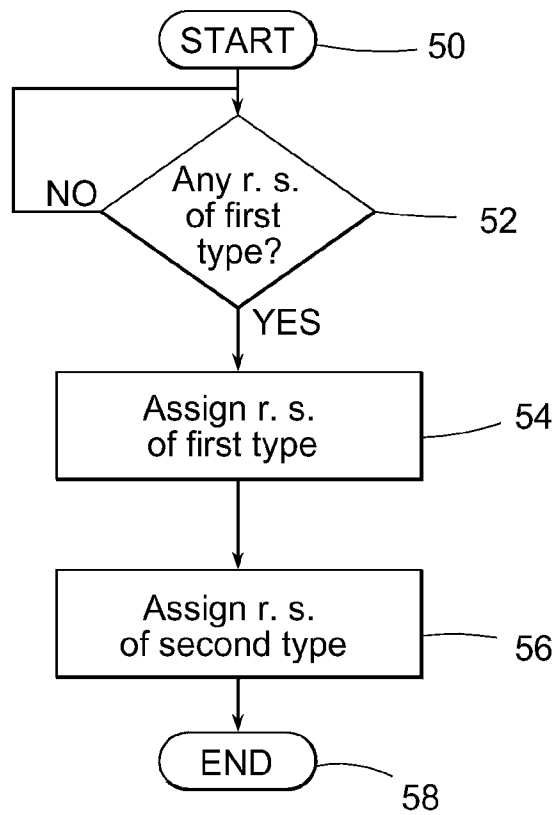

Fig. 3

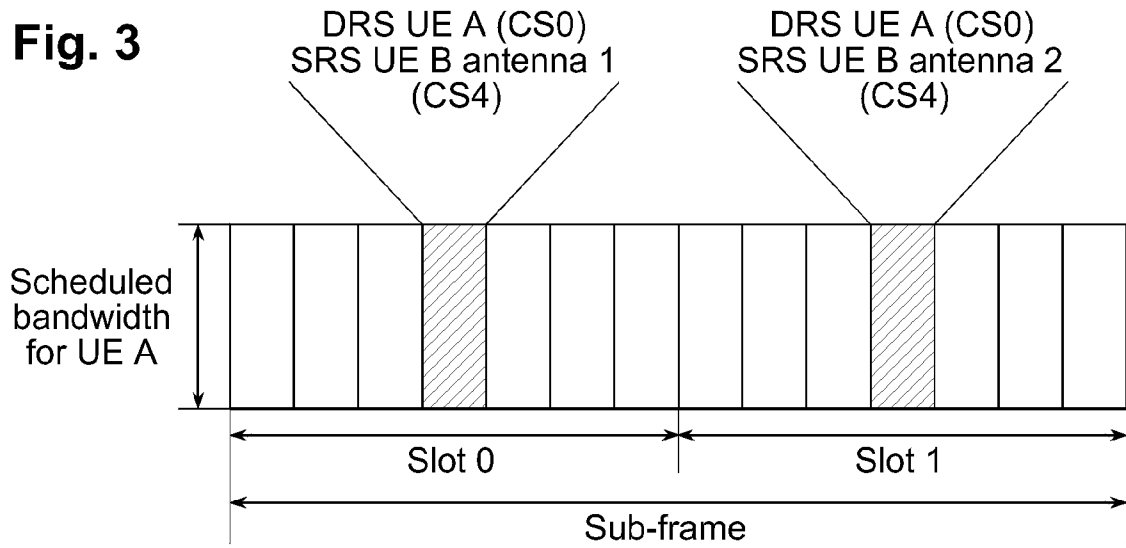
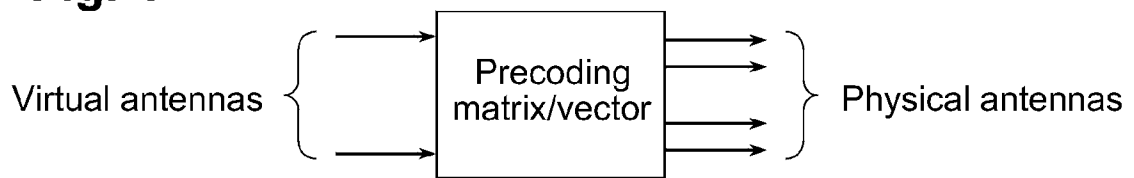

Fig. 4



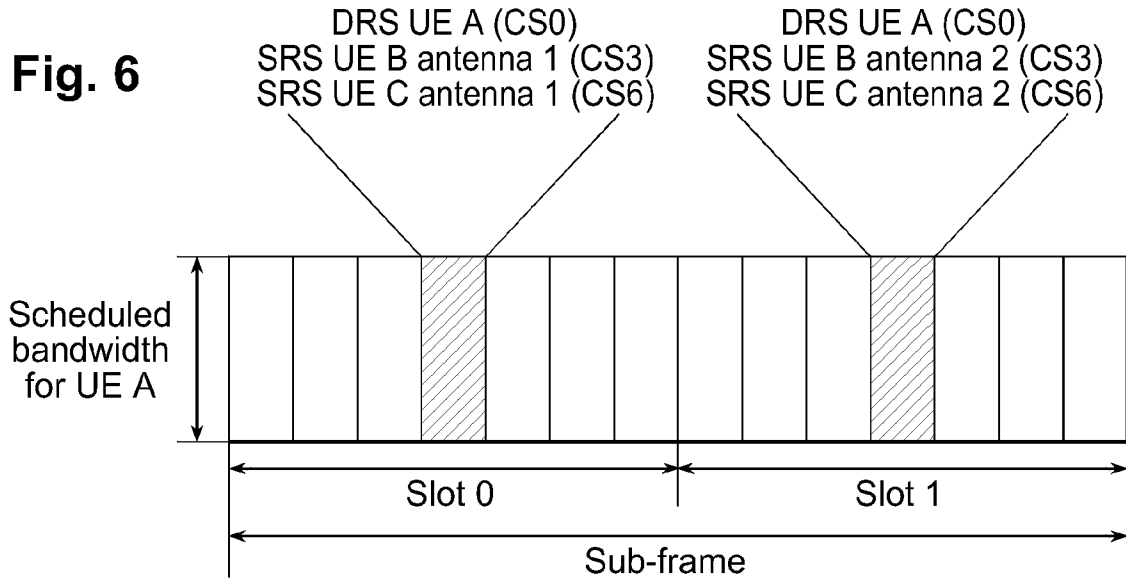
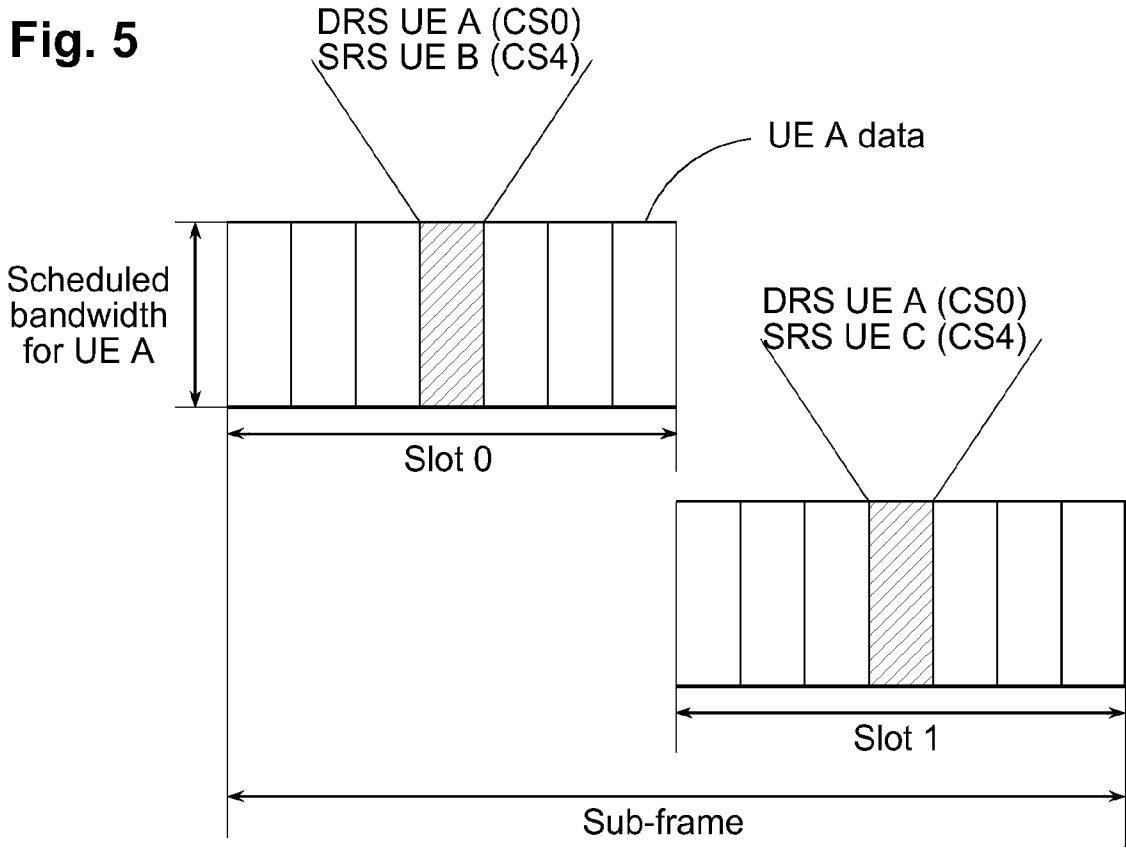

Fig. 7

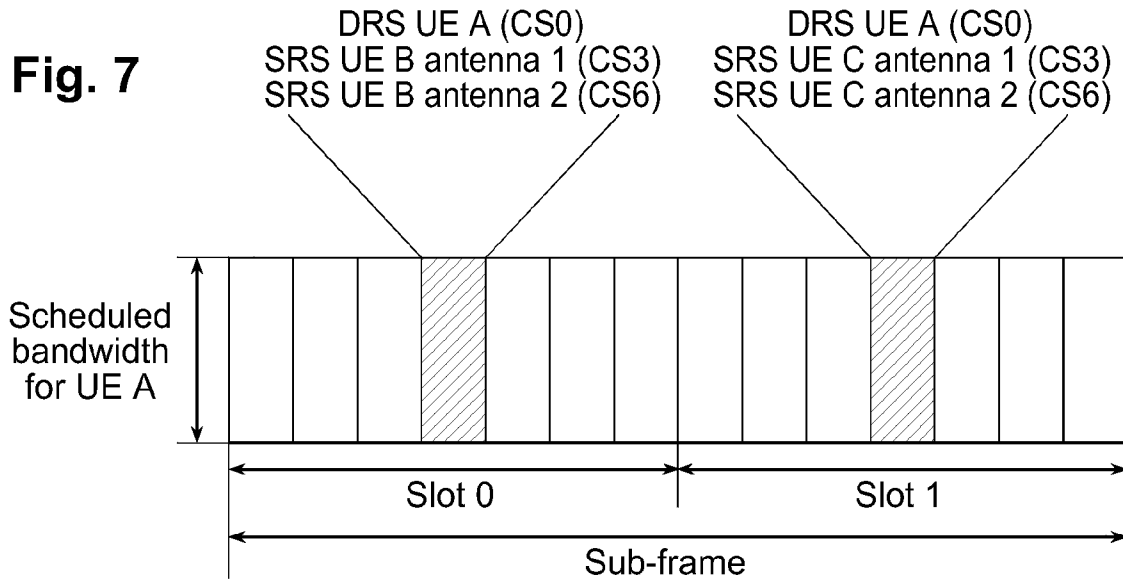

Fig. 8

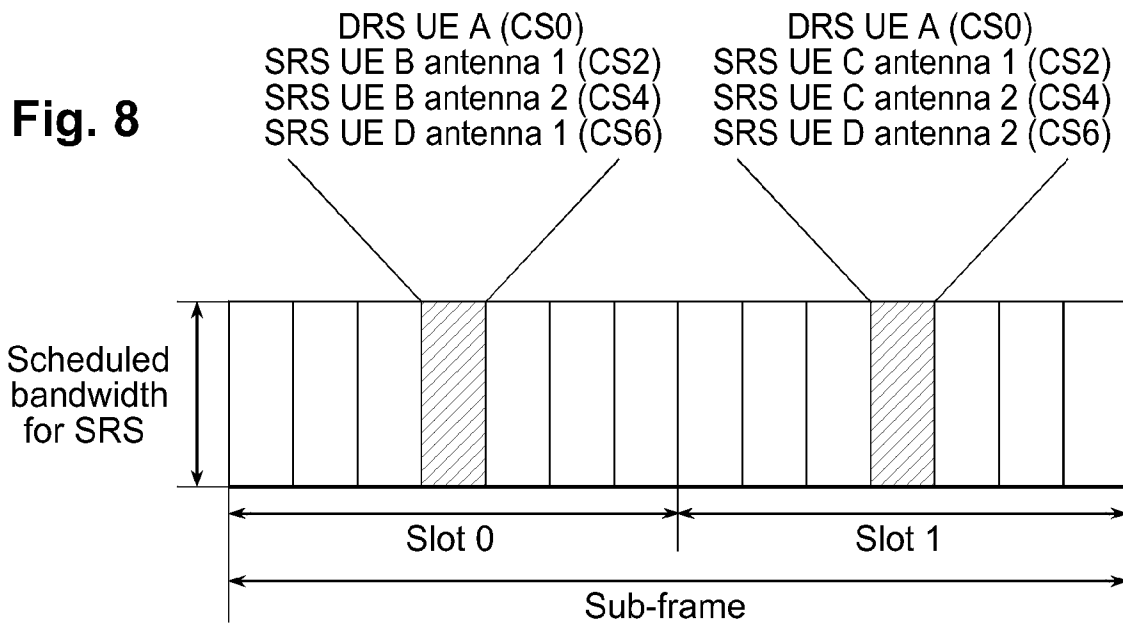

Fig. 9

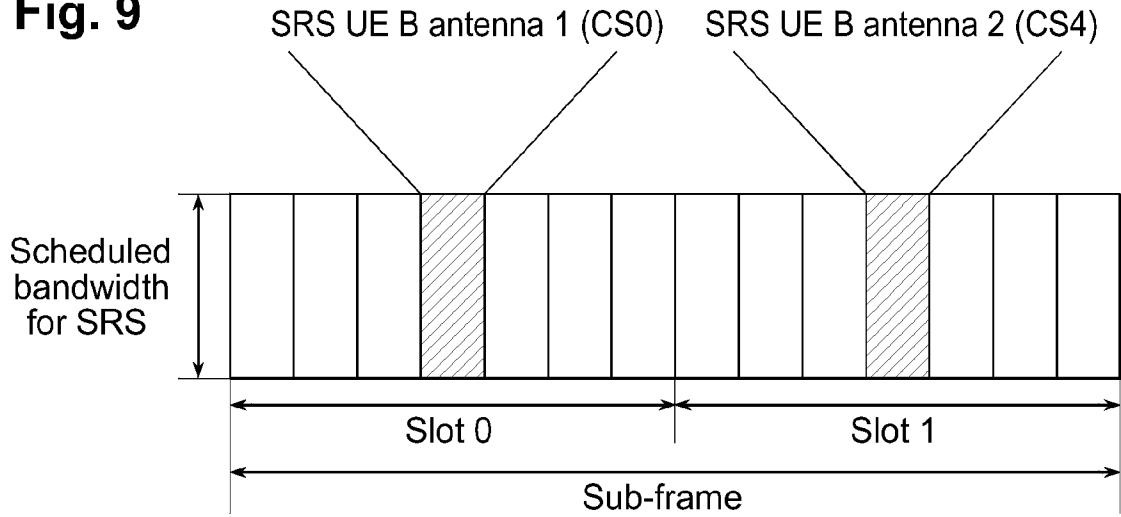

Fig. 10

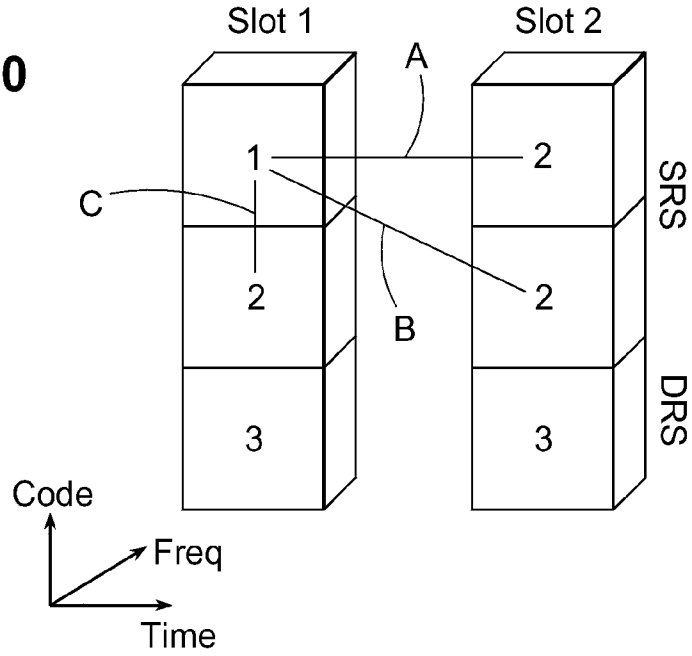

Fig. 11

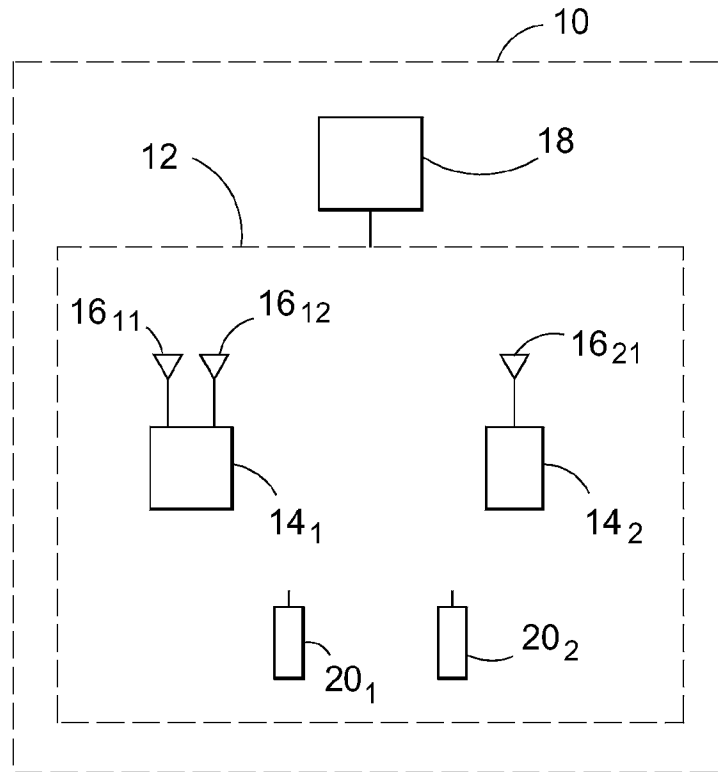
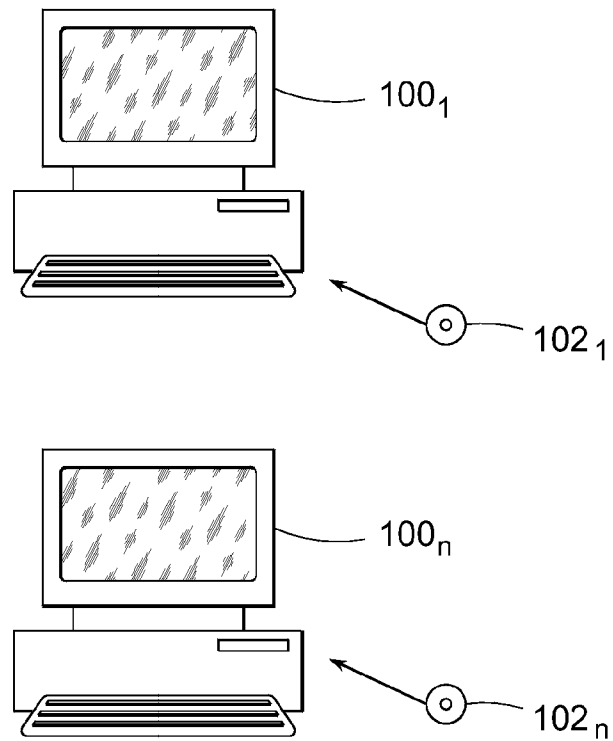

Fig. 12



INTERNATIONAL SEARCH REPORT

International application No.
PCT/CN2009/072388

A. CLASSIFICATION OF SUBJECT MATTER

H04W16/00 (2009.01) i

According to International Patent Classification (IPC) or to both national classification and IPC

B. FIELDS SEARCHED

Minimum documentation searched (classification system followed by classification symbols)

IPC: H04W; H04L; H04B

Documentation searched other than minimum documentation to the extent that such documents are included in the fields searched

Electronic data base consulted during the international search (name of data base and, where practicable, search terms used)

WPI; EPODOC; CNKI; CPRS: demodulation reference signal?, sounding reference signal?, antenna, measurement, slot

C. DOCUMENTS CONSIDERED TO BE RELEVANT

Category*	Citation of document, with indication, where appropriate, of the relevant passages	Relevant to claim No.
X	WO2009020983A1 (QUALCOMM INC) 12 Feb. 2009 (12.02.2009) figures 1, 4, 17	1, 8-11, 12, 18-21
A	WO2008093952A2 (LG ELECTRONICS INC) 07 Aug. 2008 (07.08.2008) the whole document	1-21
A	US2006023680A1 (SAMSUNG ELECTRONICS CO LTD) 02 Feb.2006 (02.02.2006) the whole document	1-21

Further documents are listed in the continuation of Box C.

See patent family annex.

<p>* Special categories of cited documents:</p> <p>“A” document defining the general state of the art which is not considered to be of particular relevance</p> <p>“E” earlier application or patent but published on or after the international filing date</p> <p>“L” document which may throw doubts on priority claim (S) or which is cited to establish the publication date of another citation or other special reason (as specified)</p> <p>“O” document referring to an oral disclosure, use, exhibition or other means</p> <p>“P” document published prior to the international filing date but later than the priority date claimed</p>	<p>“T” later document published after the international filing date or priority date and not in conflict with the application but cited to understand the principle or theory underlying the invention</p> <p>“X” document of particular relevance; the claimed invention cannot be considered novel or cannot be considered to involve an inventive step when the document is taken alone</p> <p>“Y” document of particular relevance; the claimed invention cannot be considered to involve an inventive step when the document is combined with one or more other such documents, such combination being obvious to a person skilled in the art</p> <p>“&”document member of the same patent family</p>
--	--

Date of the actual completion of the international search
12 Mar. 2010 (12.03.2010)

Date of mailing of the international search report
25 Mar. 2010 (25.03.2010)

Name and mailing address of the ISA/CN
The State Intellectual Property Office, the P.R.China
6 Xitucheng Rd., Jimen Bridge, Haidian District, Beijing, China
100088
Facsimile No. 86-10-62019451

Authorized officer
WANG Ran
Telephone No. (86-10)62411390

INTERNATIONAL SEARCH REPORT
Information on patent family members

International application No.
PCT/CN2009/072388

Patent Documents referred in the Report	Publication Date	Patent Family	Publication Date
WO2009020983A1	12.02.2009	US2009073922A1	19.03.2009
		TW200922230A	16.05.2009
WO2008093952A2	07.08.2008	KR20080072486A	06.08.2008
		KR20080096336A	30.10.2008
		GB2459058A	14.10.2009
		WO2008093952A3	05.11.2009
US2006023680A1	02.02.2006	WO2006004383A1	12.01.2006
		EP1617610A2	18.01.2006
		KR20060049923A	19.05.2006
		AU2005260259A1	12.01.2006
		CN1981467A	13.06.2007
		JP2008503176T	31.01.2008
		KR100735433B1	04.07.2007
		INKOLNP200603449E	15.06.2007
		AU2005260259B2	18.09.2008
		RU2364033C2	10.08.2009