



US 20080017323A1

(19) **United States**

(12) **Patent Application Publication**

**Peterson**

(10) **Pub. No.: US 2008/0017323 A1**

(43) **Pub. Date: Jan. 24, 2008**

(54) **HANDHELD ADHESIVE APPLICATOR**

(60) Provisional application No. 60/528,243, filed on Dec. 9, 2003.

(76) Inventor: **Burton J. Peterson**, Waterford, WI (US)

**Publication Classification**

Correspondence Address:  
**REINHART BOERNER VAN DEUREN S.C.**  
**ATTN: LINDA KASULKE, DOCKET**  
**COORDINATOR**  
**1000 NORTH WATER STREET**  
**SUITE 2100**  
**MILWAUKEE, WI 53202 (US)**

(51) **Int. Cl.**  
**B65H 37/02** (2006.01)  
(52) **U.S. Cl.** ..... **156/540**

(57) **ABSTRACT**

(21) Appl. No.: **11/780,034**  
(22) Filed: **Jul. 19, 2007**

**Related U.S. Application Data**

(63) Continuation-in-part of application No. 10/944,535, filed on Sep. 17, 2004.

A handheld adhesive segment applicator is provided for use with an adhesive segment laden carrier release tape. The handheld applicator includes an adhesive dispensing wheel upon which a roll of adhesive segment carrier release tape is mounted and a take-up core system operatively engaged to the dispensing wheel for automatically advancing and positioning the adhesive segment-laden carrier release tape.

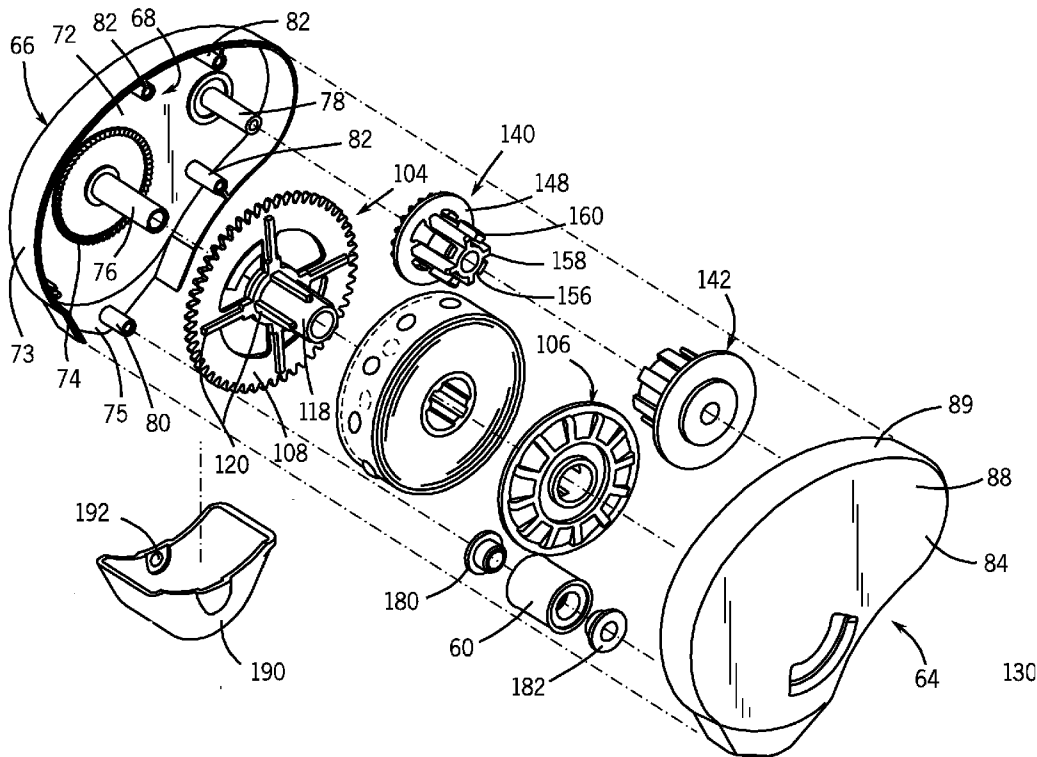

FIG. 1

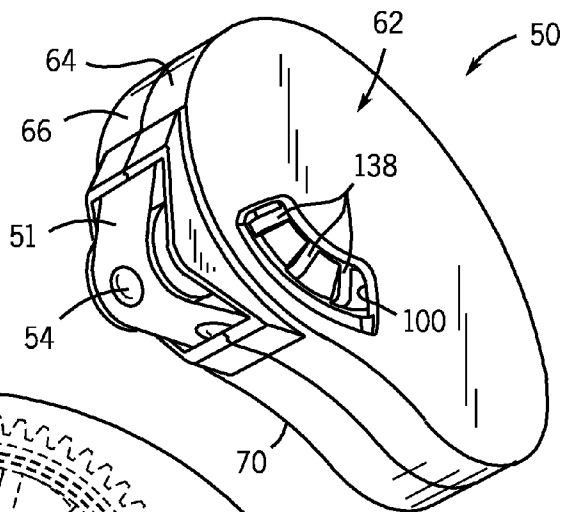

FIG. 2

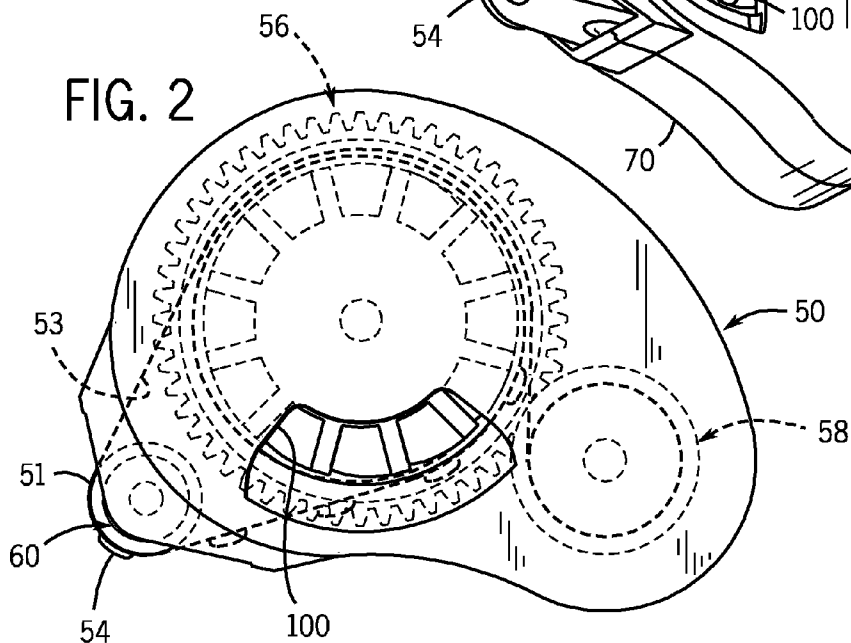
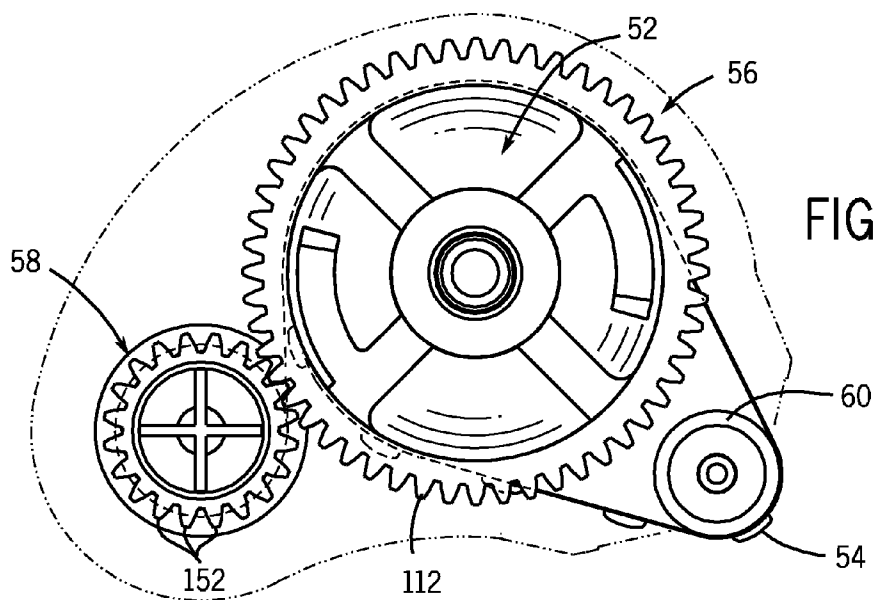

FIG. 3



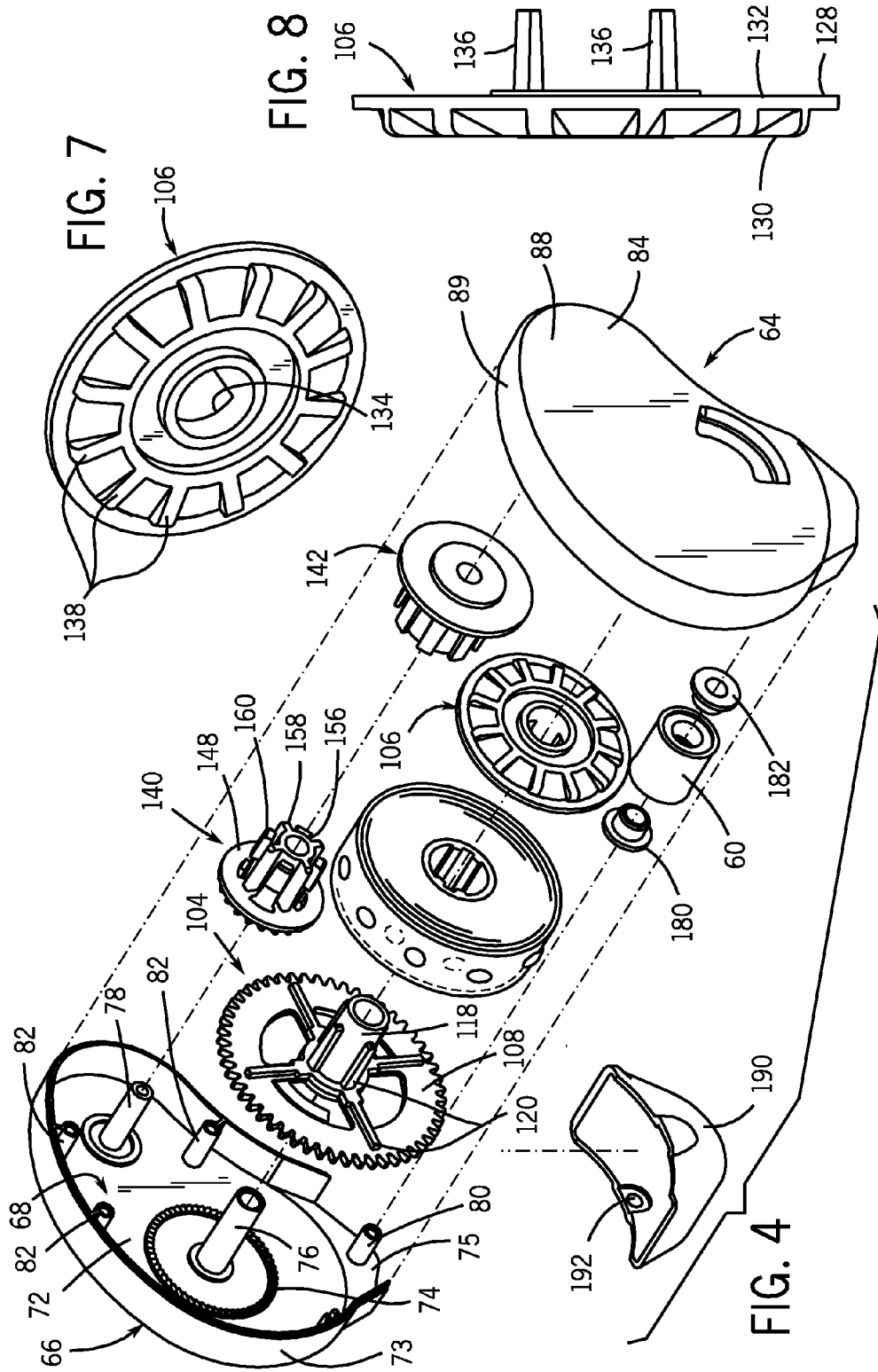

FIG. 7

FIG. 8

FIG. 4

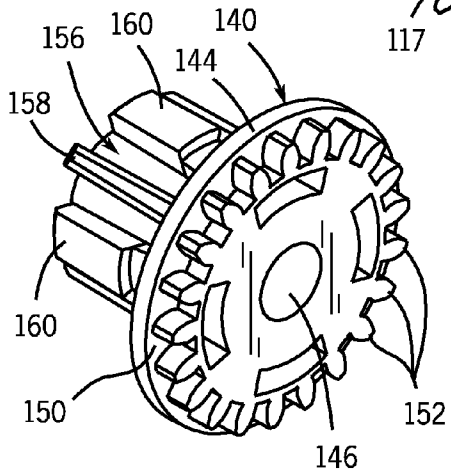
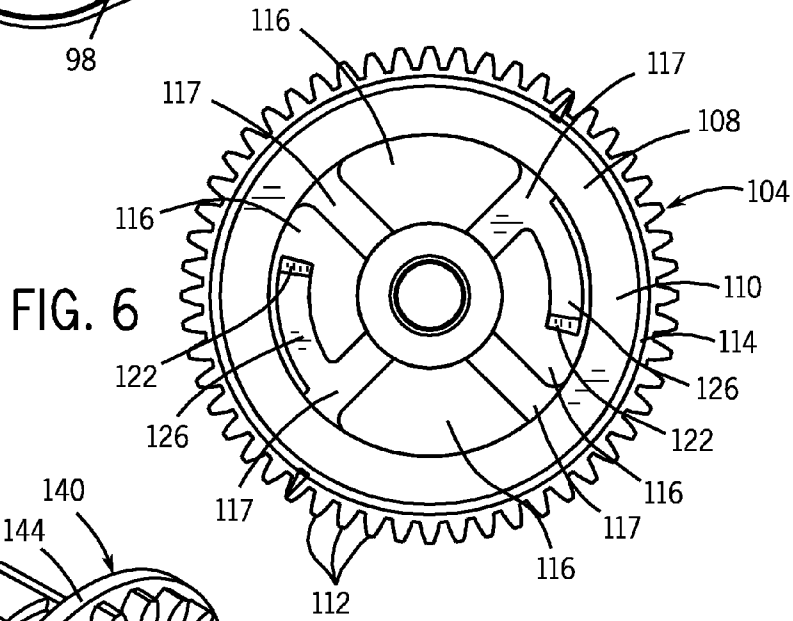
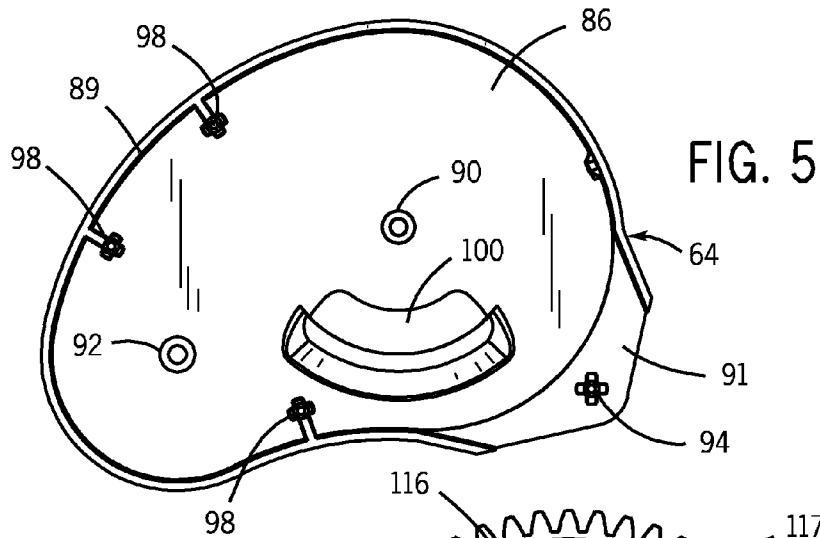

FIG. 9

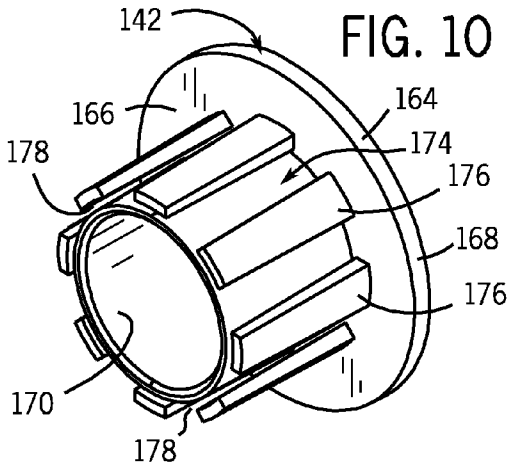
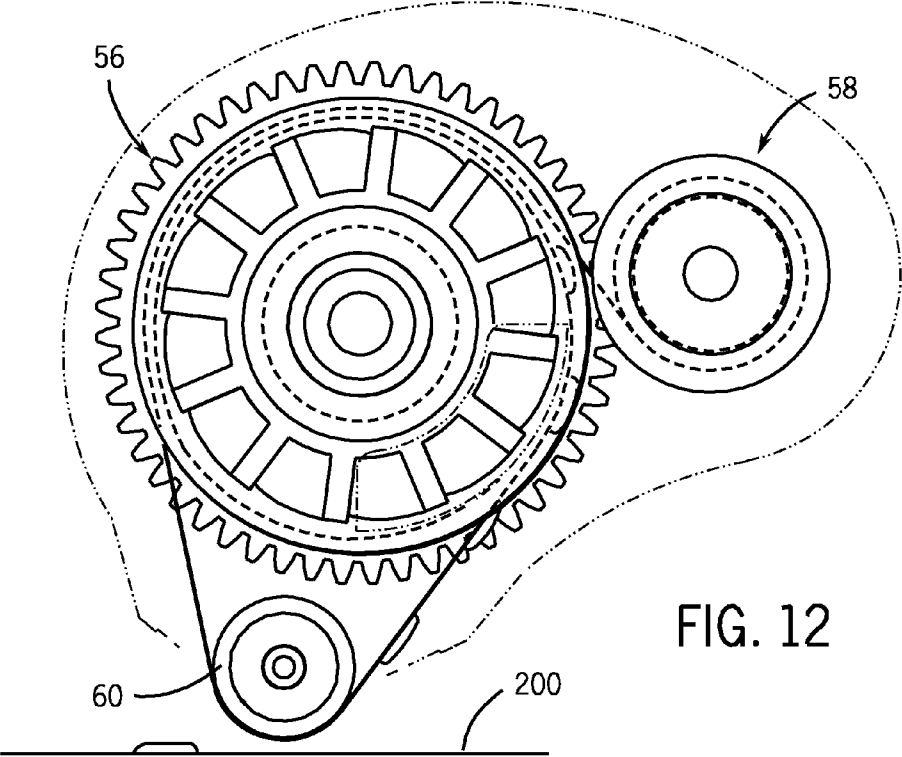
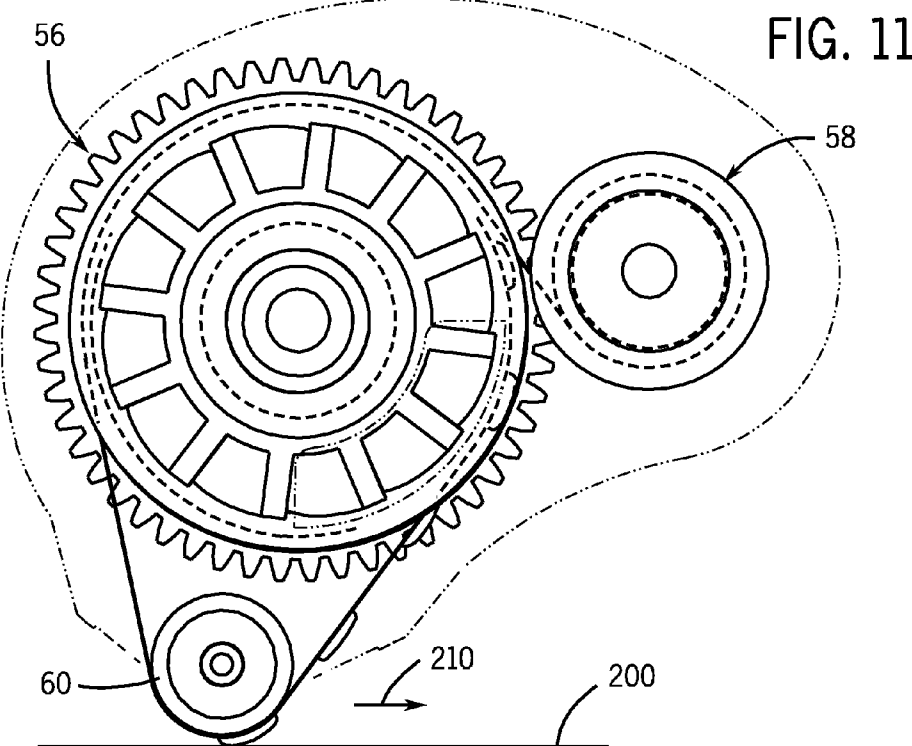
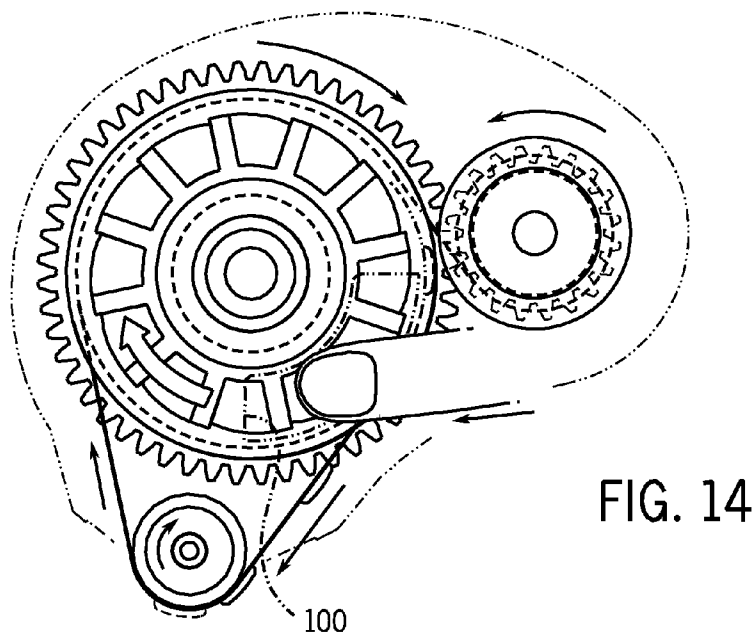
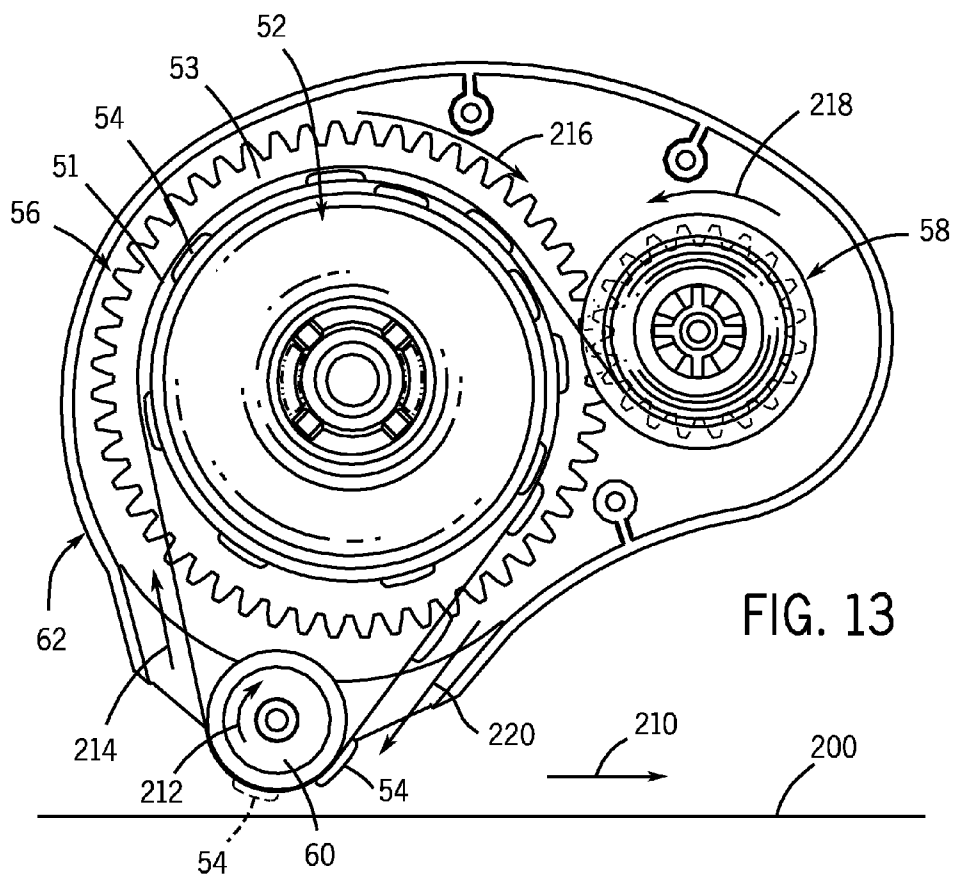

FIG. 10





**HANDHELD ADHESIVE APPLICATOR**

[0001] This application is a continuation-in-part of and claims priority benefit from U.S. patent application Ser. No. 10/944,535, entitled "SYSTEM AND METHOD FOR ADVANCING THERMOPLASTIC ADHESIVE SEGMENT DISPENSING TAPE AND APPLYING ADHESIVE SEGMENTS THEREBY" filed on Sep. 17, 2004, the entirety of which is incorporated herein by reference.

**BACKGROUND OF THE INVENTION**

**Field of the Invention**

[0002] The present invention relates generally to pressure-sensitive adhesives and their application to desired surfaces, and more specifically to a handheld adhesive segment application apparatus.

[0003] One of the most significant adhesive technical breakthroughs of the past century has been the introduction of pressure-sensitive thermoplastic adhesives. Thermoplastic adhesives have excellent adhering qualities; they can be softened by heating and firmed by cooling. These characteristics help thermoplastic adhesives produce waterproof, resilient, and long-lasting flexible bonds. Thermoplastic adhesives have what is known as a "plastic memory," meaning that each time a thermoplastic adhesive is heated, it can be molded into any desired form.

[0004] Thermoplastic adhesives have significant applications in today's industry. For example, in the preparation of mass mailings, marketers often desire to attach a card, such as a credit card or the like, to a carrier document so that a consumer can peel the card easily from the carrier document. One method of making such an attachment involves the use of a pressure-sensitive, thermoplastic adhesive.

[0005] In addition to the uses for thermoplastic adhesives described above, industry is now finding additional uses for them. For example, thermoplastic adhesives are routinely used and applied as small bond points to eliminate the use of mechanical fasteners, such as staples, screws, rivets, clips, snaps, nails, and stitching. Thermoplastic adhesives are also extensively used in the packaging and manufacture of cartons, boxes and corrugated boards, bags, envelopes, disposable products (diapers and other paper products), cigarettes, labels, and stamps. In fact, today's demand for thermoplastic adhesives extends to very broad fields of use and is not limited to assembly line-like settings.

[0006] Increasingly, industry demands thermoplastic adhesive application at on-site locations from portable, simple-to-use, efficient, inexpensive, and safe dispensing apparatuses. Additionally, such dispensing apparatuses must be able to adhere thermoplastic adhesives to non-planar, recessed, difficult to reach, or unstable surfaces. Previously known apparatuses and methods have failed to provide an adequate portable, simple-to-use, efficient, inexpensive, and safe dispensing device and a thermoplastic adhesive carrying medium capable of applying thermoplastic adhesives to non-planar, recessed, difficult to reach, or unstable surfaces.

[0007] In recent years, thermoplastic adhesive applications have expanded from industrial use to home or school use, such as in art projects or crafting. Scrapbooking, rubber stamping, sewing, gift basket making, and candlemaking are just a few examples of these newer arts and crafts, pressure-

sensitive, thermoplastic adhesive uses. As these hobbies have developed over time, the need for a simple, portable apparatus for dispensing thermoplastic adhesives has become increasingly important.

[0008] Several different types of devices are available for applying thermoplastic adhesives. For example, hot glue guns dispense heated thermoplastic adhesive to an item or surface, however, there are safety concerns when using this type of applicator, especially in schools. Additionally, such devices are inconvenient to use where an electrical source is not readily available and they are not readily portable, as a hot glue gun device must be cooled before it can be transported and used in another location.

[0009] Many adhesive applicator devices do not require the use of heat or electricity, however, they can be bulky and cumbersome to use when application of an adhesive segment to a discrete location is required. Further, conventional thermoplastic adhesive applicators are based on the industrial designs, and as such, they can be expensive to purchase, difficult to operate and heavy to transport for regular or routine use.

**SUMMARY OF THE INVENTION**

[0010] With this invention, an adhesive segment applicator apparatus is provided having an adhesive dispensing wheel and a take-up core system within a housing. The configuration of the adhesive applicator of the present invention allows the adhesive segments to be dispensed from the tape using a single hand, and using a single motion simultaneously dispense an adhesive segment and advance the next adhesive segment to a dispensing position.

[0011] The carrier release tape may be made from plain stock carrier release tape, which can be cut into individual tape strips either before or after the adhesive segment application processes. The transverse width of the preferred embodiment is approximately one inch although the dimensions of the carrier release tape strips may vary in accordance with the advancement mechanism associated with the adhesive segment applicator apparatus of the present invention with which it is used.

[0012] The second surface of the carrier release tape has a coefficient of friction different from that of the first so that adhesive segments do not adhere to the second surface as strongly as they do to the first surface. When the carrier release tape is wound into rolls, the first surface, and thus, the adhesive segments applied thereto, will be the external surface of the roll of adhesive segment-laden carrier release tape.

[0013] In certain preferred embodiments of the present invention, the adhesive segment applicator apparatus includes a carrier tape dispensing system comprising a supply wheel, a spent-tape take-up wheel and a roller are each rotatably mounted inside the housing of the adhesive segment applicator apparatus. A roll of adhesive segment-laden carrier release tape is inserted onto the supply wheel and engages the supply wheel in a secure fashion, permitting the roll of adhesive segment-laden carrier release tape to rotate when the supply wheel rotates. The supply wheel includes a gear system or another mechanism for engaging the take-up wheel.

[0014] The take-up wheel is also rotatably mounted inside the housing of the adhesive segment applicator apparatus.

The take-up wheel is operatively engaged to at least a portion of the gear teeth or gear system of supply wheel, permitting rotation of the supply wheel (and the roll of adhesive segment-laden carrier release tape) to drive rotation of the spent carrier tape take-up wheel. An adhesive dispensing roller is also rotatably mounted to the housing of the adhesive segment applicator apparatus but is positioned so that a portion of the roller is located outside the housing to provide an area of contact for the roller to contact a surface or workpiece. The adhesive segment applicator apparatus also may include a cap mounted to or removable from the housing of the adhesive segment applicator apparatus.

[0015] Preferably, the roll of adhesive segment-laden carrier release tape and adhesive dispensing system (including the supply wheel and the take-up wheel) are substantially permanently enclosed within the housing of the adhesive segment applicator apparatus, rendering the applicator disposable. In particular, the housing components are not separable once assembled so that once the adhesive on the roll of adhesive segment-laden carrier release tape is used, the roll is not replaceable. In these embodiments, the applicator housing and each of the components, including the supply wheel, take-up wheel and roller are constructed of an easily disposable, and most preferably recyclable, material.

[0016] The path of the adhesive segment-laden carrier release tape within the applicator provides the applicator with an automatic advancement function. Indeed, once mounted the roll is mounted on to the supply wheel, the carrier tape travels, with adhesive segments facing outwardly, from the supply wheel, out of the housing and over the roller at the point where an adhesive segment or segments are dispensed to the desired object or surface. The spent carrier tape then reenters the housing and passes over the roll of adhesive segment-laden carrier release tape where it is held in place within the housing by the exposed adhesive on the remaining roll of adhesive segment-laden carrier release tape on the supply wheel. The free end of the roll of adhesive segment-laden carrier release tape is mounted to the take-up wheel, and spent carrier tape is wound thereon.

[0017] The adhesive segment applicator apparatus of the present invention can be used to dispense adhesive to a workpiece and automatically advance the carrier tape to expose another adhesive segment to the workpiece. To operate the adhesive segment applicator, the roller containing an exposed adhesive segment, is placed in contact with the intended workpiece or application surface. The exposed adhesive segment is then applied to the intended surface by contacting the adhesive segment to the surface.

[0018] The carrier release tape is advanced by motion of the application process. In particular, the adhesive segment is applied to the surface by moving the adhesive segment applicator apparatus across it in the operational direction. This action causes the roller to rotate, and simultaneous advancement of the adhesive segments on the roll of carrier tape and winding of the spent carrier tape. More specifically, by virtue of the second surface of the spent carrier tape being held in place by the adhesive segments on the roll of adhesive segment-laden carrier release tape on the supply wheel, rotation of the roller, drives the supply wheel, causing the spent carrier tape to be drawn into the housing, thereby automatically advancing the adhesive laden carrier tape. By

nature of the externally exposed adhesive segments on the roll of adhesive segment-laden carrier release tape, the second surface of the spent carrier release tape adheres to the adhesive segments on the wound roll of adhesive segment-laden carrier release tape on the supply wheel and is held in place. However, because the second surface of the carrier release tape has a release property different from that of the first surface the adhesive segments do not adhere to it as strongly as they do to the first surface, the carrier tape can be advanced across the wound roll of adhesive segment-laden carrier release tape without pulling off adhesive segments from the roll.

[0019] In turn, the supply wheel drives the take-up wheel, thereby winding the spent carrier tape on to the take-up spool. Thus, an adhesive segment applicator in accordance with the present invention can be used easily to deposit a series or row of adhesive segments along a work piece surface and also wind spent carrier tape with a single motion, and using a single hand.

[0020] It may be seen that the compact, handheld adhesive segment applicator apparatus of the present invention includes a self-advancing adhesive dispensing system including an adhesive supply wheel, take-up wheel and roller that are each operatively engaged with each other to permit automatic advancement of the adhesive segment-laden carrier release tape during application of an adhesive segment to a surface. In addition, it may be seen that the present invention provides a adhesive segment applicator apparatus that automatically winds the spent carrier release tape onto a roll—thereby reducing the problem of scrap carrier tape interfering with the adhesive application process.

[0021] It may also be seen that the adhesive segment applicator apparatus of the present invention may also be configured to be compact and handheld—therefore, rendering it easy to accurately dispense adhesive using a single hand, allowing the user to stabilize the surface or workpiece with another hand (if necessary) The present invention can be disposable, such that the user may dispose of or recycle the device, rather than take the device apart for difficult or cumbersome reloading thereof.

[0022] Each implementation of the adhesive segment applicator apparatus of the present invention is of a construction which is both durable and long lasting, and will require little or no maintenance to be provided by the user throughout its operating lifetime. The adhesive segment applicator apparatuses of the present invention are also of inexpensive construction to enhance their market appeal and to thereby afford them the broadest possible market. Finally, all of the aforesaid advantages and objectives are achieved without incurring any substantial relative disadvantage.

#### DESCRIPTION OF THE DRAWINGS

[0023] These and other advantages of the present invention are best understood with reference to the drawings, in which:

[0024] FIG. 1 is a perspective view of a handheld adhesive segment applicator apparatus of the present invention;

[0025] FIG. 2 is a side plan view of the handheld adhesive segment applicator illustrated in FIG. 1, including a manual advancement opening and a portion of an advancement cap;



[0026] FIG. 3 is a side plan view of the handheld adhesive segment applicator illustrated in FIGS. 1 and 2, showing operational engagement of the supply and spent tape take-up wheels;

[0027] FIG. 4 is an exploded view of the handheld adhesive segment applicator illustrated in FIGS. 1 through 3;

[0028] FIG. 5 is a side plan view of an interior surface of a front housing piece used to construct the handheld adhesive segment applicator illustrated in FIGS. 1 through 4;

[0029] FIG. 6 is a back plan view of a tape supply gear used to construct the handheld adhesive segment applicator illustrated in FIGS. 1 through 5;

[0030] FIG. 7 is a front perspective view of an advancement cap used to construct the handheld adhesive segment applicator illustrated in FIGS. 1 through 6;

[0031] FIG. 8 is a side view of the advancement cap of the supply wheel of the handheld adhesive segment applicator illustrated in FIGS. 1 through 7;

[0032] FIG. 9 is a rear perspective view of a take-up gear used to construct the handheld adhesive segment applicator illustrated in FIGS. 1 through 8;

[0033] FIG. 10 is a front perspective view of a take-up spool used to construct the handheld adhesive segment applicator illustrated in FIGS. 1 through 10;

[0034] FIG. 11 is a side view of the handheld adhesive segment applicator illustrated in FIGS. 1 through 10, demonstrating the rolling operation of the application while applying an adhesive segment to a surface;

[0035] FIG. 12 is a side view of the handheld adhesive segment applicator illustrated in FIGS. 1 through 11, demonstrating application of an adhesive segment to a surface and automatic advancement of the roll of adhesive segment laden carrier tape;

[0036] FIG. 13 is a side view of the handheld adhesive segment applicator illustrated in FIGS. 1 through 12, illustrating a detailed view of operation of the applicator; and

[0037] FIG. 14 is a side view of the handheld adhesive segment applicator illustrated in FIGS. 1 through 13, illustrating manual advancement of the carrier tape using a finger.

#### DETAILED DESCRIPTION OF THE PREFERRED EMBODIMENT

[0038] A preferred embodiment of an adhesive segment applicator 50 of the present invention is illustrated generally in FIG. 1, with an adhesive segment-laden carrier release 52 tape including a plurality of adhesive segments 54 used therein. It will be appreciated that the applicator 50, and most preferably the applicator housing and gear components, can be constructed of a variety of substantially rigid materials. In particular, the materials of construction can include a thermoplastic material or thermoplastic composite material. It will also be appreciated that the applicator 50 of the present invention can come in a variety of colors or can be transparent, including having individual components of different colors and/or translucency, depending on the desired end-look of the applicator.

[0039] It will be further appreciated that any type of adhesive segment-laden carrier release tape can be used in the applicator 50 of the present invention and is not limited to those shown in the figures. Carrier tapes of different widths and sizes can be used. In addition, the adhesive segments may be of any size, shape or color (including transparent), depending on the desired end-use of the applicator product. Further, it will be appreciated that the roll of adhesive segment-laden carrier release tape can be configured to dispense a single, or multiple adhesive segments at a given time, also depending on the end-use application of the applicator 50.

[0040] Preferably, however, the adhesive segment-laden carrier release tape will be of the type that includes two surfaces, a first surface 51 and a second surface 53, wherein the second surface 53 of the carrier release tape has a coefficient of friction different from that of the first surface 51 so that adhesive segments do not adhere to the second surface as strongly as they do to the first surface 51. When the carrier release tape is wound into rolls, the first surface, and thus, the adhesive segments applied thereto, will be on the external surface of the roll of adhesive segment-laden carrier release tape 52.

[0041] Referring first to FIGS. 1 through 3, the adhesive segment applicator 50, in its simplest form, includes an adhesive tape supply wheel, indicated generally at 56, a spent tape, take-up wheel, indicated generally at 58, and an applicator tip or roller 60, which are each rotatably secured within an applicator housing 62 by any means known to those skilled in the art. The applicator housing 62 is preferably formed in two pieces, including a front housing portion 64 and a rear housing portion 66, as described in more detail below.

[0042] As best illustrated in FIG. 4, the rear housing portion 66 has a side wall 68 having interior and exterior surfaces 70 and 72, respectively, and a side edge 73 encompassing substantially the entire perimeter of the side wall 68. An opening or space 75 is provided in the side edge 73 for accommodating the roller 60 and the adhesive segment-laden carrier release tape 52.

[0043] The interior surface 70 of the rear housing portion 66 includes a plurality of outwardly projecting teeth 74 and a supply wheel mounting shaft 76 for operatively engaging the supply wheel 56. The interior surface 70 also includes a take-up wheel mounting shaft 78 for operatively engaging the take-up wheel 58, and a roller mounting shaft 80 for operatively engaging the roller 60. When the applicator 50 is assembled, each of the mounting shafts 76, 78 and 80 are configured to extend from the rear housing portion 66 to the front housing portion 64.

[0044] A plurality of locking pins 82 also project from the interior surface 70 of the side wall 68 of the rear housing portion 66. The locking pins 82 are configured to engage corresponding locking pins within the front housing portion 64 of the applicator 50 in order to retain the front and rear applicator housing portions 64 and 66, respectively, together.

[0045] Preferably, the teeth 70, each of the mounting shafts 76, 78 and 80 and the locking pins 82 are integrally formed within the interior surface 70 of the side wall 68 of the rear housing portion 66. However, the rear housing

portion 66 may be constructed so that the mounting shafts 76, 78 and 80 and the locking pins 82 are secured to the inside surface 70 after it is formed. It will also be appreciated that the outside surface 72 of the rear housing portion 66 can be texturized or include gripping portions to facilitate a user's ability to grasp the applicator 50 with a single hand.

[0046] Turning now to FIG. 5, in addition to FIG. 4, the front housing portion 64 has a side wall 84 having interior and exterior surfaces 86 and 88, respectively, and a side edge 89 encompassing substantially the entire perimeter of the side wall 84. An opening or space 91 is provided in the side edge 89 for accommodating the roller 60 and the adhesive segment-laden carrier release tape 52.

[0047] The interior surface 86 includes a first tubular projection or prong 90 configured to interfit and/or engage the mounting shaft 76, permitting the supply wheel 56 to be rotatably secured within the housing 62. A second tubular projection or prong 92 extending from the inside surface 86 of the front housing portion 64 is configured to interfit and/or engage take-up wheel mounting shaft 78, permitting the take-up wheel 58 to be rotatably secured within the housing 62. Likewise, a third tubular projection or prong 94 extending from the inside surface 86 is configured to interfit and/or engage the roller mounting shaft 80, permitting the roller 60 to be rotatably secured within the housing 62.

[0048] A plurality of locking pins 98 also project from the interior surface 86 of the front housing portion 64. The locking pins 98 are located within the side wall 84 so that they are aligned with and engage the locking pins 82 in the rear housing portion 66. In certain preferred embodiments of the present invention, the locking pins 98 and 82, respectively, are tubular and are configured so that they interfit with each other and lock together, so that the front and rear housing portions 64 and 66 cannot be easily separated once assembled.

[0049] The front and rear applicator housing portions 64 and 66 can be held together by any means known to those skilled in the art; however, it is preferable that once the front and rear housing portions 64 and 66 are assembled, the housing 62 will be difficult, if not impossible to separate, preventing the adhesive segment-laden carrier release tape 52 from becoming unthreaded within or removed from the applicator 50. In certain other preferred embodiments, the locking pins 98 and 82 are configured so that they interfit with each other but are easily separated as well, permitting the front and rear housing portions 64 and 66 to be separated from each other for re-loading the applicator 50 with adhesive tape 52 and reassembling it.

[0050] Preferably, each of prongs 90, 92 and 94 and the locking pins 98 are integrally formed within the interior surface 86 of the side wall 84 of the front housing portion 64. However, the front housing portion 64 may be constructed so that the prongs 90, 92 and 94 and the locking pins 98 are secured to the inside surface 86 after it is formed.

[0051] As best illustrated in FIGS. 1, 5 and 14, the front housing portion 64 includes an arcuate aperture 100 positioned within the side wall 84 in a location that will be close to the location of the adhesive tape supply wheel 56 when the applicator 50 is assembled. This aperture 100 will permit the user to manually advance the adhesive segment-laden carrier release tape 52 if required, as will be described in

more detail below with respect to FIG. 14. Further, it will also be appreciated that the outside surface 88 of the front housing portion 64 can be texturized or include gripping portions to facilitate a user's ability to grasp the applicator 50 with a single hand.

[0052] Turning next to FIGS. 6 through 8, in addition to FIGS. 3 and 4, the adhesive tape supply wheel 56 is illustrated. The adhesive tape supply wheel 56 is configured to rotatably mount on to the supply wheel mounting shaft 76 and comprises a supply gear 104 and a supply advancement cap 106. The supply gear 104 and the advancement cap are configured to hold the roll of adhesive segment-laden carrier release tape 52 therebetween.

[0053] Accordingly, the supply gear 104 includes a circular base 108 having several openings or cut-outs 116 formed therein. In between each opening 116, extension arms 117 are included, adding rigidity to the base portion 108 of the supply gear 104. The supply gear 104 further includes front and back surfaces 108 and 110, respectively, and a plurality of gear teeth 112 formed around an edge 114 thereof. The front surface 108 of the supply gear 104 includes a tubular shaft 118 with a plurality of elongated ribs 120 formed therein for securely receiving the roll of adhesive segment-laden carrier release tape 52. It will be recognized by those skilled in the art that the tubular shaft 118 can be configured in any manner that permits the supply roll of adhesive tape to be received thereon, e.g. depending on the size and shape of the core onto which the adhesive laden carrier tape 52 is wound.

[0054] As best illustrated in FIG. 6, the supply gear 104 is formed so that the back surface 110 includes at least one arcuate arm 126 extending outwardly from at least one of the extension arms 117. The arcuate arms 126 include an outwardly projecting tang 122 configured to engage at least one of the teeth 74 formed in the rear housing portion 66. During use of the adhesive applicator 50, the tangs 122 prevent rotation of the supply wheel 56 in a direction opposite the dispensing direction, and thus, prevent the carrier release tape 52 from coming loose within the applicator housing 62.

[0055] As best illustrated in FIGS. 7 and 8, the advancement cap 106 is substantially circular including a base 128 having front and back surfaces 130 and 132, respectively. The base 128 includes an opening 134 formed therein and arcuate extensions 136 projecting from the back surface 132 thereof. The arcuate extensions 136 are laterally spaced apart and sized to fit within the tubular shaft 118 of the supply gear 104. As will be appreciated, when the applicator 50 is assembled, arcuate extensions 136 are inserted into the tubular shaft 118 securing the supply gear 104 and advancement cap 106 together with the roll of adhesive segment-laden carrier release tape 52 securely positioned therebetween. The front surface 130 of the advancement cap 106 includes a plurality of spaced-apart ridges 138 that permit the supply wheel 56 to be manually advanced if desired.

[0056] Preferably, each of the supply gear 104 and the advancement cap 106 are constructed of a single piece of material; however, they may be constructed of multiple pieces and assembled together, as will be well known to those skilled in the art.

[0057] Turning, next to FIGS. 9 and 10, in addition to FIGS. 1 through 4, the take-up wheel 58 is illustrated. The

take-up wheel **58** comprises a take-up gear **140** and a take-up spool **142**. The take-up gear **140** includes a circular base **144** having a circular opening **146** formed therein for accommodating the take-up wheel mounting shaft **78**, and further includes front and back surfaces **148** and **150**, respectively. The back surface **150** of the take-up gear **140** includes a plurality of gear teeth **152** configured to operatively interfit with the plurality of gear teeth **112** formed around the edge **114** of the supply gear **104** of the supply wheel **56**, in order to provide an adhesive applicator **50** with automatic advancement of the carrier tape as well as simultaneous winding of spent carrier tape.

[0058] The front surface **148** of the take-up gear **140** includes a tubular shaft **156** with a plurality of elongated, space-apart ribs **158** extending radially therefrom. The take-up gear **140** also includes a plurality of fingers **160** extending outwardly from the front surface **148** of the base **144**. Each finger **160** is formed between two of the ribs located on the tubular shaft **156**, and are sized to provide a friction fit with the take-up spool **142**. It will be recognized by those skilled in the art that the tubular shaft **156**, ribs **158** and fingers **160** can be configured in any manner the permits the take-up spool **142** to be securely but removably secured to the take-up gear **140**.

[0059] The take-up spool **142** is substantially circular including a base **164** having front and back surfaces **166** and **168**, respectively. The base **164** includes an opening **170** formed therein for accommodating the take-up wheel mounting shaft **78**. A tubular shaft **174** having ribs **176** formed therein extends from front surface **166** of the base **164**. The diameter of the tubular shaft **174** is sized to fit around the tubular shaft **156** and ribs **158** on the take-up gear **140** thereby securing the take-up spool **142** to the take-up gear **140**. The take-up spool **142** further includes at least one slot **178**, located between at least one of the ribs **176** on the tubular shaft **174** for securing a free end of the roll of adhesive segment-laden carrier release tape **52**.

[0060] Preferably, each of the take-up gear **140** and the take-up spool are constructed of a single piece of material; however, they may be constructed of multiple pieces and assembled together, as will be well known to those skilled in the art.

[0061] As best illustrated in FIGS. **1** through **4**, the roller **60** is rotatably secured within the housing **62** using hub elements **180** and **182**. In use, the roller **60** is the point of application for the adhesive segments **54** as they are dispensed on to a surface. The hub elements **180** and **182** are substantially identical to each other and are configured to fit over the roller mounting shaft **80**, while rotatably securing the roller **60** therebetween. It will be appreciated that the roller **60** may be rotatably secured within the housing **62** by any means known to those skilled in the art.

[0062] The roller **60** may be constructed of a silicone or rubber material to provide the appropriate coefficient of friction between the roller **60** and the carrier tape to prevent slipping or unwanted movement of the carrier tape with respect to the roller **60**. Preferably, the roller **60** may be formed of or contain a soft overmolded cushion or resilient cushion around its external circumference to permit the roller **60** of the adhesive segment applicator apparatus **50** to engage non-flat, recessed, difficult to reach, or unstable surfaces.

[0063] The adhesive segment applicator apparatus **50** may also include a cover or cap **190** that is hingedly attached to the housing **62** with a fastener **192** and/or a cap can be removably mounted or snapped on to the applicator housing **62** in order to cover the adhesive segments on the carrier tape and also to protect the roller **60**.

[0064] Turning next to FIGS. **11** through **14**, in addition to FIGS. **1** through **4**, assembly and operation of the adhesive applicator **50** of the present invention is illustrated. The supply wheel **56** is rotatably mounted within the rear housing portion **66** by inserting the supply gear **104** on to the supply wheel mounting shaft **76**, loading and securely mounting a roll of adhesive segment-laden carrier release tape **52** thereto and securing it in place using the advancement cap **106**. As illustrated in the FIGS., the roll of adhesive segment-laden carrier release tape **52** is loaded on to the supply wheel **56** with the adhesive segments **54** disposed on the outside or exposed surface of the carrier tape.

[0065] Likewise, the take-up wheel **58** is rotatably mounted within the rear housing portion **66** by inserting the take-up gear **140** on to the take-up wheel mounting shaft **78**, securely mounting the free end of the roll of adhesive segment-laden carrier release tape **52** within one of the slots **178** on the take-up spool **142** and securing it into place on the take-up gear **140**.

[0066] As illustrated in FIGS. **3**, **13** and **14**, once installed on the take-up gear mounting shaft **78**, it can be seen that a portion of the gear teeth **152** on the take-up gear **140** functionally engage a portion of the gear teeth **112** on the edge **114** of the supply gear **104** of the supply gear **104**. Clearly, as the supply wheel **56** rotates (e.g. is automatically or manually driven in the dispensing direction of the applicator **50**), the operational interaction of the gear teeth **112** of the supply gear **104** and the gear teeth **152** on the take-up gear **140** causes the take-up spool to also rotate. (The take-up gear **140** is the driven gear).

[0067] Accordingly, FIG. **13** best illustrates the path of the adhesive segment-laden carrier release tape **52** within the applicator **50**. Once mounted on to the supply wheel **56**, the carrier tape travels, with adhesive segments facing out, from the supply wheel **56**, out of the housing **62** and over the roller **60** at the point where an adhesive segment(s) is dispensed to a surface **200**. The spent carrier tape then continues over the roller **60**, enters the housing **60** and passes over the roll of adhesive segment-laden carrier release tape **52** where it is held in place within the housing **60** by the exposed adhesive **54** on the remaining roll of adhesive segment-laden carrier release tape **52**. The free end of the roll of adhesive segment-laden carrier release tape **52** is mounted to the take-up wheel, and spent carrier tape is wound thereon. It will be appreciated that due to the respective sizes of the supply wheel **56** and the take-up wheel **58**, a limited amount of slip or slack in the carrier tape is permitted inside the housing **62**.

[0068] Finally, after the roll of adhesive segment-laden carrier release tape **52** is properly threaded, the housing **62** is secured together by aligning the locking pins **82** and side edge opening **75** in the rear housing portion **66** with the locking pins **98** and side edge opening **91** in the front housing portion **64**. In this way, each of the mounting shafts **76**, **78** and **80** in the rear housing portion **66** will be aligned and engaged with each of the first, second and third prongs

90, 92 and 94 in the front housing portion 64. The front and rear housing portions 64 and 66 are then secured together and locked into position by pushing the housing components together. Once assembled, it can be seen that a portion of the roller 60 is outside of the housing 62 to facilitate application of the adhesive to a work-piece or surface.

[0069] In certain preferred embodiments of the present invention, the applicator 50 is configured to be disposable, i.e. the housing components are not separable once assembled so that once the adhesive on the roll of adhesive segment-laden carrier release tape is used, the roll is not replaceable. In these embodiments, the applicator housing 62 and each of the components, including the supply wheel, take-up wheel and roller are constructed of an easily disposable, and most preferably recyclable, material.

[0070] However, consistent with the broader aspects of the invention, and as well known to those skilled in the art, the adhesive applicator 50 can be designed to be reusable, including the ability to easily separate the housing components 64 and 66 and replace an empty roll of adhesive segment-laden carrier release tape with a new roll of adhesive segment-laden carrier release tape.

[0071] As illustrated in FIGS. 11 through 14, the adhesive segment applicator apparatus 50 of the present invention can be used to dispense adhesive to a workpiece and automatically advance the carrier tape to expose another adhesive segment to the workpiece. To operate the adhesive segment applicator 50 of the present invention, the adhesive segment-laden carrier release tape 52 is installed as described above, and an adhesive segment 54 is exposed at the roller 60 of the adhesive segment applicator 50. As illustrated in FIG. 11, the roller 60, containing the adhesive segment 54, is placed in contact with the intended workpiece or application surface 200. Then, as illustrated in FIG. 12, the adhesive segment 54 is then applied to the intended surface 200 by contacting the adhesive segment 54 to the surface 200.

[0072] The carrier release tape is advanced by motion of the application process. In particular, as the adhesive segment 54 is applied to a surface 200, e.g., by moving the adhesive segment applicator apparatus 50 across the surface 200 in the direction 210, the roller 60 rotates in the direction 212.

[0073] By virtue of the second surface 53 of the spent carrier tape being held in place by the adhesive segments 54 on the roll of adhesive segment-laden carrier release tape 52 on the supply wheel 56, rotation of the roller 60, drives the supply wheel 56 in direction 216, causing the spent carrier tape to be drawn into the housing 62 in the direction 214 and advances the adhesive laden carrier tape in the direction 220. By nature of the externally exposed adhesive segments 54 on the roll of adhesive segment-laden carrier release tape 52, the second surface 53 of the spent carrier release tape adheres to the adhesive segments 54 on the wound roll of adhesive segment-laden carrier release tape 54 on the supply wheel 56 and is held in place. However, because the second surface 53 of the carrier release tape has a release property different from that of the first surface 51 the adhesive segments 54 do not adhere to it as strongly as they do to the first surface 51, the carrier tape can be advanced across the wound roll of adhesive segment-laden carrier release tape 52 without pulling off adhesive segments 54 from the roll.

[0074] In turn, the supply wheel 56 drives the take-up wheel 58 in the direction 218, thereby winding the spent

carrier tape on to the take-up spool 142. Thus, an adhesive segment applicator apparatus 50 in accordance with the present invention and can be used easily to deposit a series or row of adhesive segments 53 along a work piece surface 200 and also wind spent carrier tape with a single motion, and using a single hand.

[0075] Turning for the moment to FIG. 14, it can be seen that the opening 100 provides the applicator 50 with a manual advancement mechanism. In particular, if the roll of adhesive segment-laden carrier release tape 52 comes loose within the housing 62 and/or the automatic advancement feature of the applicator 50 is not working properly, the adhesive segments can be advanced manually. Using a finger or thumb, the user can rotate the supply wheel by gripping or moving the ribs 138 in the operational direction 216. As will be appreciated, even if the supply wheel, and thus they adhesive segments, are manually rotated, this motion will still cause simultaneous winding of the spent carrier tape on to the take-up wheel as described above.

[0076] Although an exemplary embodiment of the adhesive segment applicator apparatus of the present invention has been shown and described with reference to particular embodiments and applications thereof, it will be apparent to those having ordinary skill in the art that a number of changes, modifications, or alterations to the invention as described herein may be made, none of which depart from the spirit or scope of the present invention. All such changes, modifications, and alterations should therefore be seen as being within the scope of the present invention.

What is claimed is:

1. A handheld adhesive segment dispensing apparatus, comprising:

- (a) a housing;
- (b) a tape supply wheel rotatably mounted to the housing;
- (c) a roll of flexible carrier release tape mounted to the tape supply wheel, the roll of flexible carrier release tape extending longitudinally and having a transverse width, opposed first and second release surfaces, and a plurality of adhesive segments arrayed non-contiguously in a longitudinally spaced-apart progression along the first release surface of the carrier release tape;
- (d) a take-up wheel rotatably mounted to the housing, adapted to receive an end of the flexible carrier release tape, and operatively coupled to the tape supply wheel such that rotation of the tape supply wheel drives rotation of the take-up wheel; and
- (e) an adhesive dispensing roller rotatably mounted to the housing;

wherein the tape supply wheel, take-up wheel, and adhesive dispensing roller are mounted with respect to each other and the housing such that a flexible carrier release tape from a roll of flexible carrier release tape held on the supply wheel may be extended from the supply wheel, around the adhesive dispensing roller, and onto the take-up wheel such that rotation of the supply wheel to advance the carrier release tape to position an adhesive segment at the adhesive dispensing roller simultaneously rotates the take-up wheel to wind carrier release tape with the adhesive segments removed therefrom around the take-up wheel.

2. The adhesive segment dispensing apparatus of claim 1, wherein the housing includes an opening formed in a side thereof located substantially near the supply wheel, wherein the supply wheel is manually advanceable through the opening in the housing.

3. The adhesive segment dispensing apparatus of claim 2, wherein the supply wheel comprises a supply gear and an advancement cap and the roll of flexible carrier release tape is securely mounted therebetween.

4. The adhesive segment dispensing apparatus of claim 3, wherein the advancement cap has a first surface securely engaged to the supply gear and a second surface comprising a plurality of manually engagable ribs, wherein a least a portion of the ribs are always accessible through the opening in the housing.

5. The adhesive segment dispensing apparatus of claim 1, wherein each of the supply wheel and the take-up wheel comprise a gear wheel having a plurality of gear teeth formed thereon and wherein a portion of the gear teeth on the supply wheel is operatively engaged to a portion of the gear teeth of the take-up wheel.

6. The adhesive segment dispensing apparatus of claim 1, wherein the supply wheel comprises a supply gear and an advancement cap and the roll of flexible carrier release tape is securely mounted therebetween.

7. The adhesive segment dispensing apparatus of claim 1, wherein the take-up wheel comprises a take-up gear and a take-up core secured together and rotatably secured within the housing.

8. A handheld, disposable adhesive segment dispensing apparatus, comprising:

a housing having a first opening;

a roller element rotatably secured to the housing, wherein at least a portion of the roller element extends out of the first opening in the housing;

a roll of flexible carrier release tape rotatably mounted inside the housing and operatively engaged to the roller element such that rotation of the roller element causes simultaneous rotation of the roll of flexible carrier release tape, wherein the roll of flexible carrier release tape extends longitudinally and has a transverse width, opposed first and second release surfaces, and a plurality of adhesive segments arrayed non-contiguously in a longitudinally spaced-apart progression along the first release surface of the carrier release tape; and

a take-up wheel rotatably mounted inside the housing, having a portion at least operatively engaged to the roll of flexible carrier release tape, such that rotation of the roll of flexible carrier release tape causes simultaneous rotation of the take-up wheel, whereby spent carrier release tape is wound on to the take-up wheel.

9. The disposable adhesive segment dispensing apparatus of claim 8, wherein the housing comprises first and second housing portions secured together with the take-up wheel completely secured therein, wherein at least one of the portions includes a second opening located substantially near the roll of flexible carrier release tape, wherein the roll of flexible carrier release tape is manually advanceable therethrough.

10. The disposable adhesive segment dispensing apparatus of claim 9, wherein the first and second housing portions are substantially unseparable once secured together.

11. The disposable adhesive segment dispensing apparatus of claim 9, wherein the roll of flexible carrier release tape further comprises a supply gear having a plurality of gear teeth formed on an edge thereof and an advancement cap, wherein the roll of flexible carrier release tape is positioned therebetween and wherein a least a portion of the advancement cap is always accessible through the second opening in the housing.

12. The disposable adhesive segment dispensing apparatus of claim 11, wherein the take-up wheel comprises a take-up gear having a plurality of gear teeth formed on an edge thereof and a take-up spool for securing a free end of the roll of flexible carrier release tape, wherein a portion of the gear teeth on the supply wheel is operatively engaged to a portion of the gear teeth of the take-up wheel.

13. A handheld adhesive segment dispensing apparatus, comprising:

a housing having an inside surface;

a tape supply wheel including a plurality of gear teeth formed around the circumference thereof, the supply wheel rotatably mounted to the inside surface of the housing and configured to receive a roll of

a roll of flexible carrier release tape having first and second release surfaces and including a plurality of adhesive segments disposed thereon, wherein the roll of flexible carrier release tape is formed such that the plurality of adhesive segments are outwardly exposed;

a take-up wheel rotatably mounted to the inside surface of the housing and comprising a take-up gear including plurality of gear teeth, wherein a portion of the plurality of gear teeth on the take-up gear is always in operational engagement with the plurality of gear teeth on the tape supply wheel such that rotation of the supply wheel causes simultaneous rotation of the take-up wheel; and

a roller rotatably secured to the housing, and having a portion extending outside the housing; wherein the roll of carrier release tape extends from the supply wheel to the roller and back to the supply wheel such that the roller is in operational engagement with the supply wheel, wherein rotation of the roller causes simultaneous rotation of the supply wheel and advancement of an adhesive segment on the roll of flexible carrier release tape.

14. The adhesive segment dispensing apparatus of claim 13 wherein the supply wheel, the take-up wheel and the roller are mounted to the housing via a support structure extending from the inside surface of the housing.

15. The adhesive segment dispensing apparatus of claim 13, wherein the housing further comprises an opening formed in a side thereof located substantially near the supply wheel, wherein the supply wheel is manually advanceable through the opening in the housing.

16. The adhesive segment dispensing apparatus of claim 15, wherein the supply wheel comprises an advancement cap having a surface including a plurality of manually engagable ribs, wherein a least a portion of the ribs are always accessible through the opening in the housing.

17. The adhesive segment dispensing apparatus of claim 13 wherein the tape supply wheel, take-up wheel, and roller are mounted with respect to each other such that the flexible carrier release tape having the first release surface with the adhesive segments arrayed thereon facing outward may be extended from the supply wheel, around the roller, over the

first release surface of a portion of the roll of flexible carrier release tape held on the supply wheel, and onto the supply wheel such that the portion of the carrier release tape extending between the roller and the take-up wheel are held in position by adhesive segments on the first release surface.

\* \* \* \* \*