



(11) **EP 2 457 453 A1**

(12) **EUROPEAN PATENT APPLICATION**

(43) Date of publication:
30.05.2012 Bulletin 2012/22

(51) Int Cl.:
A24D 1/02 (2006.01)

(21) Application number: **12156227.6**

(22) Date of filing: **02.04.2007**

(84) Designated Contracting States:
AT BE BG CH CY CZ DE DK EE ES FI FR GB GR HU IE IS IT LI LT LU LV MC MT NL PL PT RO SE SI SK TR
Designated Extension States:
HR

(72) Inventors:
• **Garg, Rajesh K.**
Richmond, VA Virginia 23233 (US)
• **Phan, Tony A.**
Richmond, VA Virginia 23236 (US)

(30) Priority: **31.03.2006 US 787540 P**

(74) Representative: **Marlow, Nicholas Simon**
Reddie & Grose
16 Theobalds Road
London
WC1X 8PL (GB)

(62) Document number(s) of the earlier application(s) in accordance with Art. 76 EPC:
07789552.2 / 2 007 232

(71) Applicant: **Philip Morris Products S.A.**
2000 Neuchâtel (CH)

Remarks:

This application was filed on 20-02-2012 as a divisional application to the application mentioned under INID code 62.

(54) **Slit banded paper**

(57) Wrappers of smoking articles having slit banded regions 30 exhibit both low ignition propensity and reduced rates of self-extinguishment under free burn conditions. The slit banded regions comprises first 31, second 32 and third 33 zones, with the second zone having

greater permeability than the first and third zones, which comprise add-on material, the first second and third zones being of substantially the same width as each other. A method of making the wrapper as is also disclosed, as are smoking articles including the wrappers.

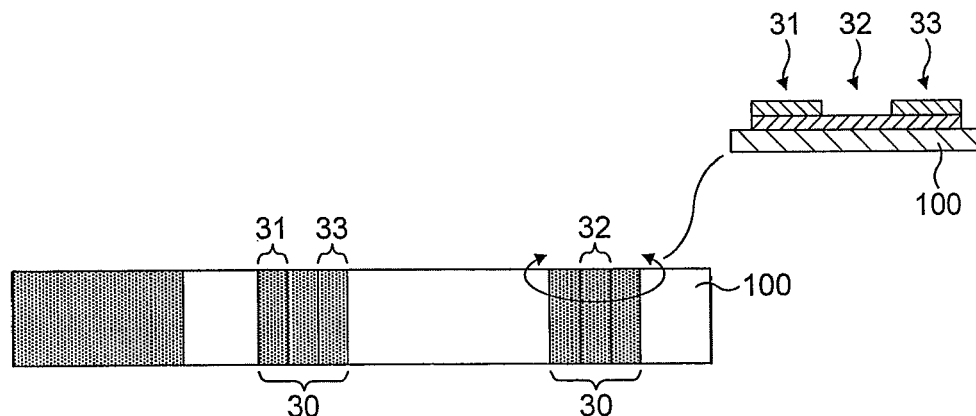

FIG. 3

Description

5 [0001] According to the invention there is provided a wrapper of a smoking article comprising a base web and a transverse banded region of add-on material, the transverse banded region sufficient to cause extinguishment of smoking articles comprising the transverse banded region when left upon a substrate, the wrapper further comprising at least one air permeable second, intermediate zone along the transverse banded region defining first and third zones of add-on material outward of the second zone, the widths of the first, second and third zones being substantially equal, such that the occurrences of self-extinguishments of smoking articles comprising the the said wrapper is statistically reduced over those without the second zone. Preferably, the width of each of the first, second and third zones is about 2 mm.

10 [0002] In another aspect the invention provides a wrapper of a smoking article comprising a base web and at least one transverse banded region comprising first, second and third zones. The first and third zones comprise add-on material, which reduces permeability of the wrapper. The first and third zones each have a width such that if either of said first or third zone were applied separately to wrappers of smoking articles, the smoking articles would exhibit statistically significant occurrences of total burn through and statistically few or no occurrences of self-extinguishment under free burn conditions. The sum of the widths of the first and third zones is such that if the zones were applied to wrappers of smoking articles as a single continuous band (without a slit or other discontinuity), the smoking articles would exhibit statistically few or no occurrences of total burn through and statistically significant occurrences of self-extinguishment under free burn conditions. The first and third zones are separated by the second zone. The wrapper has greater permeability along the second zone than along the first and third zones. The second zone has a width less than or equal to either width of the first and third zones, so that lit smoking articles comprising the first, second and third zones exhibit statistically reduced occurrences of self-extinguishment under free burn conditions, as compared to smoking articles comprising wrappers whereon the first and third zones are applied as a single continuous band, while maintaining statistically few or no occurrences of total burn through.

15 [0003] In another aspect the invention is provides a wrapper of a smoking article comprising a base web and a transverse banded region of add-on material. The transverse banded region is sufficient to cause extinguishment of smoking articles comprising the transverse banded region when left upon a substrate. The wrapper further comprises at least one air permeable, intermediate zone along the transverse banded region such that the occurrences of self-extinguishments of smoking articles comprising the wrapper is statistically reduced over those without the intermediate zone.

20 [0004] In another aspect, the invention provides a wrapper of a smoking article comprising a base web and at least one transverse banded region comprising first, second and third zones on the base web. The at least one transverse banded region is free of fillers. The first and third zones are outward of the second zone, and the second zone has a greater permeability compared to the first and third zones.

25 [0005] In another aspect, the invention provides a wrapper of a smoking article comprising a base web and at least one transverse banded region comprising first, second and third zones on the base web. The first and third zones are outward of the second zone, the second zone has a greater permeability compared to the first and third zones, and the second zone and the first and third zones comprise add-on material.

30 [0006] In another aspect, the invention provides a method of making a banded wrapper of a smoking article comprising supplying a base web and forming at least one transverse banded region comprising first, second and third zones on the base web. The first and third zones are outward of the second zone, the second zone has a greater permeability compared to the first and third zones, and at least the first and third zones are formed from an add-on material free of fillers and optionally at least one of the zones is formed at least in part from an add-on material which includes a filler.

35 [0007] In another aspect, the invention provides a method of making a banded wrapper of a smoking article comprising supplying a base web and forming at least one transverse banded region comprising first, second and third zones on the base web. The first and third zones are outward of the second zone, the second zone has a greater permeability compared to the first and third zones, and the second zone and the first and third zones are formed from an add-on material.

BRIEF DESCRIPTION OF THE DRAWINGS

40 [0008]

FIGs. 1-3 are illustrations of smoking articles comprising the slit banded paper as described herein.

FIGs. 4-5 illustrate alternate embodiments of smoking articles comprising the split banded paper as described herein.

45 FIG. 6 is a schematic view of a multiple stage printing apparatus.

DETAILED DESCRIPTION

50 [0009] Preferably, a smoking article extinguishes when placed onto a substrate, and the tendency to do so is referenced

herein as a smoking article having "low ignition propensity". Ideally, a low propensity smoking article will continue to burn when freely suspended such as within the holder of an ashtray or when being held in the hand without puffing ("free burn"). Many prior cigarette designs that achieve low ignition propensity requirements exhibit high rates of self-extinguishment under free burn conditions.

5 [0010] The phrase "total burn through" as used herein, refers to testing by American Society of Testing and Materials (ASTM) Standard E2187-04, "Standard Test Method for Measuring the Ignition Strength of Cigarettes", which provides a measure of the capability of a lit banded-papered cigarette, positioned on a combustible substrate, to continue burning without puffing. Thus, "total burn through" refers to the situation in which the coal proceeds entirely through a banded region on a cigarette wrapper and does not cause extinguishment of the lit cigarette. Further, the phrases "self-extinguish under free burn conditions" or "self-extinguishment under free burn conditions" as used herein, refer to the extinguishment of a lit cigarette without puffing, when such cigarette is under free burn conditions.

10 [0011] The banded regions described herein exhibit both low ignition propensity and reduced rates of self-extinguishment under free burn conditions. The banded regions are preferably formed by printing, specifically gravure printing, as described in detail below. As an alternative to printing, the banded regions may comprise a slurry of highly refined fibrous cellulose (e.g., fibers, fibrils, microfibrils, or combinations thereof) or other add-on material applied using various spray or coating techniques, including application techniques that utilize a moving orifice applicator at the forming section of a paper-making machine as described in commonly owned US 5 997 691 and US 6 596 125, the contents of which are hereby incorporated by reference in their entirety.

15 [0012] In one embodiment, the banded region can comprise first, second and third zones of add-on material, which may be applied by any of the methods disclosed herein, wherein the second zone includes perforations which preferably are filled with an occluding material which melts or is evaporated when the burning coal approaches the banded region to thereby provide the second zone with increased permeability.

20 [0013] Thus, provided is a wrapper of a smoking article comprising a base web and at least one transverse banded region comprising first, second and third zones. The first and third zones comprise add-on material, which reduces permeability of the wrapper. The first and third zones each have a width such that if either of said first or third zone were applied separately to wrappers of smoking articles, the smoking articles would exhibit statistically significant occurrences of total burn through and statistically few or no occurrences of self-extinguishment under free burn conditions (e.g., after testing a batch of 20 to 50 cigarettes). The sum of the widths of the first and third zones is such that if the zones were applied to wrappers of smoking articles as a single continuous band (without a slit or other discontinuity), the smoking articles would exhibit statistically few or no occurrences of total burn through and statistically significant occurrences of self-extinguishment under free burn conditions. The first and third zones are separated by the second zone. The second zone comprises less add-on material than the first and third zones or no add-on material. The wrapper has greater permeability along the second zone than along the first and third zones. Lit smoking articles comprising the first, second and third zones exhibit statistically reduced occurrences of self-extinguishment under free burn conditions, as compared to smoking articles comprising wrappers whereon the first and third zones are applied as a single continuous band, while maintaining statistically few or no occurrences of total burn through. Preferably, the first and third zones are of uniform add-on material across the first and third zones.

25 [0014] Total weight of add-on material for the banded region preferably lies in the range of 0.5 grams per square meter (g/m^2) to $15\text{g}/\text{m}^2$, more preferably in the range of from $0.5\text{g}/\text{m}^2$ to $3\text{g}/\text{m}^2$, even more preferably in the range of from $0.5\text{g}/\text{m}^2$ to $1.5\text{g}/\text{m}^2$, approximately. Conventional cigarette paper is permeable, with the permeability commonly designated in CORESTA, which measures paper permeability in terms of volumetric flow rate (cm^3/sec) per unit area (cm^2) per unit pressure drop (cm of water). Permeability of the cigarette paper normally exceeds 20 CORESTA and preferably, the cigarette paper has a permeability of about 33 to about 60 CORESTA and a basis weight of about $22\text{g}/\text{m}^2$ to $30\text{g}/\text{m}^2$. However, permeability through the banded regions and the underlying cigarette paper preferably lies in the range of 0 to 15 CORESTA. The reduction in permeability preferably restricts air flow needed to support combustion of the cigarette coal in the vicinity of the banded region.

30 [0015] The first and third zones preferably have a greater basis weight in grams per square meter than the intermediate second zone; for example, the basis weight in grams per square meter of the first and third zones may be at least twice the basis weight in grams per square meter of the second zone. The second zone may comprise a gap. As used herein, the term "gap" refers to a discrete area of a banded region, between the first and third zones, lacking any permeability reducing add-on material (i.e., containing no layers of permeability reducing add-on material). In order to aid combustion in the second zone, the wrapper may comprise iron oxide at the location of the second zone. The second zone preferably has a greater permeability than the first and third zones.

35 [0016] The at least one transverse banded region preferably comprises a first printed layer contacting the base web and a second printed layer, preferably having an equal or greater basis weight in grams per square meter than the first printed layer, on the first printed layer. However, the second and/or subsequent layers may be less in basis weight than the first layer. For example, the basis weight in grams per square meter of the second printed layer may be at least twice the basis weight in grams per square meter of the first printed layer. In an embodiment, the second zone may comprise

a single printed layer and the first and third zones may each comprise at least two printed layers (more preferably three or more layers). Alternatively, the first and third zones may each comprise at least three or four printed layers, and the second zone may comprise only one or two or no printed layers.

5 [0017] Non-banded areas of the base web preferably do not comprise permeability reducing add-on material. As described below with reference to FIG. 2, the transverse banded region may comprise greater than three zones. For example, the transverse banded region may comprise, for example, five zones, with the second and fourth zones separating the first, third and fifth zones and the wrapper having greater permeability along the second and fourth zones than along the first, third and fifth zones.

10 [0018] Also provided is an wrapper of a smoking article comprising a base web and a transverse banded region of add-on material. The transverse banded region is designed to cause extinguishment of smoking articles comprising the transverse banded region when left upon a substrate. The wrapper further comprises a more permeable, intermediate zone along the transverse banded region such that the occurrences of self-extinguishments of smoking articles comprising the wrapper is statistically reduced over those without the intermediate zone. In a further embodiment, a wrapper of a smoking article comprises a base web and at least one transverse banded region comprising first, second and third zones on the base web. The at least one transverse banded region can be free of fillers and optionally at least one of the zones is formed at least in part from an add-on material which includes a filler. The add-on material is preferably uniform across the first and third zones. The first and third zones are outward of the second zone, and the overall wrapper structure at the second zone has a greater permeability compared to the overall wrapper structure at the first and third zones.

20 [0019] Additionally provided is a wrapper of a smoking article comprising a base web and at least one transverse banded region comprising first, second and third zones on the base web. The first and third zones are outward of the second zone, the second zone has a greater permeability compared to the first and third zones, and the second zone and the first and third zones comprise add-on material.

25 [0020] The wrappers of the invention are preferably supplied on bobbins and it is preferred that the wrapper on the bobbin comprises evenly spaced apart transverse banded regions or a repeating series of transverse banded regions.

30 [0021] Moreover, provided is a method of making a banded wrapper of a smoking article comprising supplying a base web and forming at least one transverse banded region comprising first, second and third zones on the base web. The first and third zones are outward of the second zone, the second zone has a greater permeability compared to the first and third zones, and at least the first and third zones are formed from an add-on material free of fillers. Optionally at least one of the zones is formed at least in part from an add-on material which includes a filler. The add-on material is preferably uniform across the first and third zones.

35 [0022] Furthermore, provided is a method of making a banded wrapper of a smoking article comprising supplying a base web and forming at least one transverse banded region comprising first, second and third zones on the base web. The first and third zones are outward of the second zone, the second zone has a greater permeability compared to the first and third zones, and the second zone and the first and third zones are formed from an add-on material. Optionally at least one of the zones is formed at least in part from an add-on material which includes a filler. The add-on material is preferably uniform across the first and third zones.

40 [0023] FIGs. 1-3 illustrate smoking articles comprising slit banded paper as described herein. Specifically, FIG. 1 illustrates a smoking article having two banded regions 10, each comprising first and third zones of add-on material 11, 13 separated by a second zone 12, which may be in the form of a gap or may be in the form of a zone of reduced add-on material. The first and third zones of add-on material 11, 13 may each be, for example, about 2 mm to 5 mm, preferably about 2 mm to 3 mm, wide, and the second zone 12 may be, for example, about 1 mm to 2 mm wide. More specifically, the first and third zones of add-on material 11, 13 may each be, for example, about 3 mm wide, and the second zone 12 may be, for example, about 1.5mm or 2 mm wide. The first and third zones of add-on material 11, 13 preferably comprise multiple layers of add-on material, such as, for example, two, three or four layers of add-on material. The add-on material is preferably uniform across the first and third zones 11, 13.

45 [0024] FIG. 2 illustrates a smoking article having two banded regions 20, each comprising first, third and fifth zones of add-on material 21, 23, 25 separated by second and fourth zones 22, 24, which may be in the form of gaps or in the form of reduced levels of add-on material. The first, third and fifth zones of add-on material 21, 23, 25 may each be, for example, about 2mm to 3mm wide, and the second and fourth zones 22, 24 may each be, for example, about 1mm to 2mm wide. More preferably, the first, third and fifth zones of add-on material 21, 23, 25 may each be, for example, about 2mm wide, and the second and fourth zones 22, 24 may each be, for example, about 1mm wide or less. The first, third and fifth zones of add-on material 21, 23, 25 preferably comprise multiple layers of add-on material, such as, for example, two, three or four layers of add-on material. The add-on material is preferably uniform across the first, third and fifth zones 21, 23, 25.

55 [0025] FIG. 3 illustrates a smoking article having two banded regions 30, each comprising first and third zones of add-on material 31, 33 separated by a second zone of less add-on material 32. The first and third zones of add-on material 31, 33 may each be, for example, about 2 mm to 3 mm wide, and the second zone of less add-on material 32 may be,

for example, about 1 mm to 2 mm wide. More preferably, the first and third zones of add-on material 31, 33 may each be, for example, about 3 mm wide, and the second zone of less add-on material 32 may be, for example, about 2 mm wide or less. The first and third zones of add-on material 31, 33 preferably comprise multiple layers of add-on material, such as, for example, two, three or four layers of add-on material, while the second zone of less add-on material 32 may comprise, for example, one or two layers of add-on material. The add-on material is preferably uniform across the first and third zones 31, 33. Although second zones 32 are operative at a 1 mm width, the embodiment performs better at a 1.2 mm width or greater.

[0026] Referring to FIGs. 1-3, slit banded paper facilitates use of wrappers of lower permeability for a given level of CO than prior designs of banded paper. For example, it was found in some circumstances that a tobacco rod comprising paper having a permeability of 33 CORESTA and a CO (FTC) delivery of 11 mg would produce 15 mg of CO (FTC) if previous versions of bands were applied without further change. In order to counteract this increase, the permeability of the wrapper would have to be raised to about 46 CORESTA. Such changes create a multitude of consequence in cigarette design, such as, for example, impacting puff count, possibly lessening machinability of the paper, and the like. In contrast, the slit banded paper having a permeability of 33 CORESTA provided 12 mg CO (FTC). Thus, the slit banded banded technology described herein facilitates application of bands with a lesser impact on CO levels (FTC).

[0027] Referring to FIGs. 4 and 5, further embodiments may include banded regions wherein the zones extend longitudinally instead of circumferentially. More specifically, FIG. 4 corresponds to banded region configuration of FIG. 2 with the zones extend longitudinally instead of circumferentially, and FIG. 5 corresponds to banded region configuration of FIG. 3 with the zones extend longitudinally instead of circumferentially.

[0028] In a preferred embodiment, the first layer of each banded region is preferably formed using an aqueous occlusive composition, which extends completely across the banded region. The successive layer (or layers) of each banded region may be formed by using the same aqueous film forming composition or different aqueous compositions. For example, multiple layers may all comprise layers containing exclusively starch or multiple layers may comprise one or more layers containing exclusively starch and one or more layers containing calcium carbonate (in any order). During gravure printing, the occlusive composition is preferably heated to a temperature where its viscosity lies within the range of viscosities suitable for gravure printing. When the heated occlusive composition is applied, the occlusive composition is cooled or quenched and may be gelatinized. Thus, a portion of the free water in the occlusive composition becomes bound and unavailable to soak or migrate into underlying fibers of the base web. That binding of free water inhibits formation of waviness, cockling, and/or wrinkling in the base web. Successive layers of the banded regions preferably have increased thickness relative to the first layer. The banded regions provide a reduction in permeability to the underlying base web, which preferably restricts air flow needed to support combustion of the cigarette coal in the vicinity of the banded region. Further details of progressive multi-pass printing can be found in commonly owned U.S. Provisional Application No. 60/707,964 entitled PROGRESSIVE MULTI-PASS PRINT BANDED PAPER filed August 15, 2005, the contents of which are hereby incorporated by reference in their entirety.

[0029] The occlusive composition used in the occlusive composition may be selected from the group consisting of starch, alginate, carrageenan, guar gum, pectin, and mixtures thereof. Preferably, the occlusive composition comprises starch, more preferably oxidized starch, such as, for example, tapioca starch, more specifically oxidized tapioca starch. In embodiments, the occlusive composition preferably does not contain fillers, such as, for example, calcium carbonate, which would increase the burn rate through the banded region. In a preferred embodiment, the occlusive composition used for printing comprises water and about 20% to about 50%, by weight, of the occlusive composition. At higher concentrations of the occlusive composition in the composition, the composition may experience gelatinization when its temperature is rapidly reduced. Thus, the binding of free water into the printed banded region may occur.

[0030] At room temperature (about 23°C), the high-solids-content occlusive composition has a viscosity exceeding about 2 mPa·s (200 centipoise (cP)) and is unsuitable for gravure printing; however, at a temperature in the range of about 40°C to about 90°C, the viscosity of the occlusive composition is decreased sufficiently for use as a gravure printing composition. For gravure printing, the upper limit of suitable viscosity is about 2 mPa·s (200 cP). Most preferably, the occlusive composition has a viscosity of about 1 mPa·s (100 cP) at a temperature in the range of 40°C to 90°C so that the composition can be quenched on contact with the paper after gravure printing at that temperature. The viscosity of the composition at room temperature is also important. The high viscosity at room temperature is needed so that the occlusive composition gels at room temperature.

[0031] Preferably, the banded regions are applied to the wrapper using a successive gravure printing process. Gravure printing operations are capable of precise registry of successive printing operations. Accordingly, gravure printing can be used to effectively print not only the first layer of the banded regions, but also the optional successive layers.

[0032] In a successive gravure printing process, preferably after the first layer is applied to the base web it is allowed to dry thereon using suiting arrangements, prior to being advanced to a second gravure printing station where a second layer is applied to the first layer using conventional successive-pass gravure printing equipment. Preferably, the second layer is coextensive with the first layer in both width and length; however, the second layer may have a different basis weight in grams per square meter than the first layer. The occlusive composition of the second layer gels on the cooler

first layer - and free water does not migrate or become absorbed by the paper. Preferably, the second layer is allowed to dry using suitable arrangements prior to being advanced to successive gravure printing station(s) where successive layer(s) are applied. Preferably, the successive layer(s) are coextensive with the previous layer(s) in both width and length (*i.e.*, the layers do not have a stepped appearance); however, the successive layer(s) may have different basis weight in grams per square meter than the previous layer(s) or may comprise different add-on compositions. Preferably, successive layer(s) are preferably allowed to dry after the printing of each successive layer in accordance with well-known gravure printing techniques and conventional gravure printing systems.

[0033] The gravure printing process can be used immediately following paper manufacture, *i.e.*, at a printing station at a location near the end of the paper making machine. Alternatively, the gravure printing process can be used in connection with reels carrying the wrapper onto which the banded regions are to be printed. For example, a reel of wrapper having a selected permeability and a selected basis weight is mounted so that the wrapper can be unspooled from the reel as a continuous base web.

[0034] The base web advances or passes through a first gravure printing station where the first layer of each banded region is printed on the paper. The printing process may be applied to the felt side or the wire side of the paper, or both. Next, the wrapper passes through a second gravure printing station where a second layer of each banded region is printed on the corresponding first layer. Additional layers are applied in a similar manner as described. Finally, the wrapper with the printed banded regions is wound up on a collection reel. The collection reel is then cut into bobbins. The bobbins are then used during manufacture of the desired smoking article in conventional tobacco rod making machines.

[0035] The apparatus at each of the gravure printing stations is essentially the same in its material aspects. Accordingly, it will suffice to describe one of the gravure printing stations in detail, it being understood that the other gravure printing stations have common features, unless otherwise noted. A single pass technique can be used to make the banded paper instead of a multi-pass technique.

[0036] At the first gravure printing station, the apparatus includes a gravure cylinder or roller generally mounted for rotation around a horizontal axis. The generally cylindrical surface of the roller is patterned (*i.e.*, with dots, lines, cells, etc.) in a suitable process to define a negative of the first layer of banded regions. Conventional engraving (etching), chemical engraving, electronic engraving, and photo etching can be used to pattern the surface of the gravure cylinder. The circumference of the roller is determined such that it is an integral multiple of the sum of the nominal distance between banded regions plus the banded region width. Thus, for each revolution of the roller, that integral number of first layers of the banded regions is printed on the wrapper.

[0037] With gravure printing, while each layer of add-on material may be applied uniformly, each layer of add-on material need not be applied uniformly. For example, a layer of add-on material may be applied such that discrete portions of the layer have differing grams per square meter weights than other areas of the layer. This may be accomplished, for example, by printing a discrete portion of the layer having a differing basis weight than other areas of the layer in a separate printing stage using add-on material having a differing basis weight. Alternatively, a layer of add-on material may be applied such that discrete portions of the layer have differing depths than other areas of the layer. This may be accomplished, for example, by patterning the gravure cylinder or roller so as to provide a discrete portion of the layer having a differing depth than other areas of the layer.

[0038] The multiple zones, for example, first, second and third zones, of the banded regions described herein may be applied in a single printing stage or multiple printing stages. When applied in multiple printing stages, each zone which contains add-on material may be applied in a separate printing stage. For example, for a banded region containing first, second and third zones, wherein only the first and third zones contain add-on material, the first zone may be applied in a first printing stage and the third zone may be applied in a second printing stage. Alternatively, when applied in a single printing stage, the zones containing add-on material are applied using an appropriately patterned gravure cylinder or roller. For example, for a banded region containing first, second and third zones, wherein only the first and third zones contain add-on material, the gravure cylinder or roller is patterned so as to apply add-on material only in the first and third zones.

[0039] An impression cylinder is mounted for counter-rotation on an axis parallel to the axis of the roller. In some applications, the impression cylinder includes a nonmetallic resilient surface. The impression cylinder is positioned between the roller and a backing roller, which is also mounted for rotation on an axis parallel to the axis of the roller and which counter-rotates relative to the impression cylinder. One of the functions provided by the backing roller is stiffening the central portions of the impression cylinder so that the uniform printing pressure is attained between the roller and the impression cylinder. The gravure cylinder or roller and the impression cylinder cooperate to define a nip through which the base web advances during the printing process. That nip is sized to pinch the base web as it moves between the gravure cylinder and the impression cylinder. The nip pressure on the base web ensures the correct transfer of the composition from the cylinder to the paper.

[0040] A reservoir contains the occlusive composition discussed above for forming banded regions on the wrapper. The reservoir communicates with a suitable pump which is capable of handling the viscous occlusive composition. The

occlusive composition may then flow to a suitable heat exchanger where the temperature of the occlusive composition is elevated so that it lies in the range of about 40°C to about 90°C so that the viscosity of the occlusive composition is adjusted to a level which is suitable for gravure printing. As discussed above, viscosity for gravure printing usually needs to be less than about 200 cP. Preferably, the temperature of the occlusive composition is selected so that the viscosity is less than about 100 cP.

[0041] While a separate heat exchanger is disclosed, it may be desirable to provide thermal conditioning of the occlusive composition in the reservoir itself. For example, heating elements and stirring apparatus may be included in the reservoir to maintain the elevated temperature for the occlusive composition. Placement of the thermal conditioning in the reservoir has the advantage of making pump selection and operating requirements simpler since the pump need not handle the occlusive composition at the higher viscosity associated with lower temperatures because the occlusive composition would already be heated and, therefore, at the lower viscosity. Whether thermal conditioning occurs in the reservoir or in a separate heat exchanger, it is important that the thermal conditioning step occur at a temperature selected to avoid scorching the occlusive composition. Scorching can cause discoloration of the occlusive composition, and can affect the occlusive characteristics of the composition. Thus, scorching is to be avoided while the occlusive composition is subjected to thermal conditioning.

[0042] Regardless of where the thermal conditioning step occurs, the heated occlusive composition is delivered to a suitable applicator that spreads the occlusive composition along the length of the gravure cylinder. That spreading step may be effected by pouring or spraying the occlusive composition onto the gravure cylinder, or simply by delivering the liquid occlusive composition to a bath of occlusive composition that collects at the bottom of the gravure cylinder, between the gravure cylinder and a collector. The cylinder may be heated to prevent premature cooling of the composition.

[0043] Generally, the collector extends vertically around the gravure roller to a height sufficient to collect the bath, but to a height well below the top of the gravure cylinder. When the bath reaches the top of the collector, occlusive composition can flow through a drain at the bottom of the apparatus back into the reservoir. Thus, the occlusive composition circulates through the printing station and can be maintained at suitable printing viscosity by the thermal conditioning apparatus discussed above.

[0044] As the gravure cylinder rotates through the applicator and/or the bath, the occlusive composition adheres to the surface of the gravure cylinder, including in the impressions provided therein to define the banded regions. Further rotation of the gravure cylinder toward the nip moves the cylinder surface past a suitable doctor blade. The doctor blade extends along the length of the gravure cylinder and is positioned so that it wipes the surface of the gravure cylinder. In this way, those portions of the gravure cylinder that define the nominal spacing between adjacent banded regions is essentially wiped clean of the occlusive composition, while engraved portions of the gravure cylinder that define the banded regions themselves advance toward the nip full of the occlusive composition.

[0045] As the wrapper and the surface of the gravure cylinder move through the nip, the occlusive composition is transferred to the surface of the wrapper. The linear speed or velocity of the wrapper matches the tangential surface speed of both the gravure cylinder and the impression cylinder as the wrapper passes through the nip. In that way, slippage and/or smearing of the occlusive composition on the wrapper are avoided.

[0046] The thickness of the multilayer banded regions preferably is less than about 20% of the thickness of the base web, and may be less than 5% of the thickness of the base web. The thickness of the first layer of the banded region applied in the first gravure printing station, preferably is less than 4% of the base web thickness, and may be less than 1% of the base web thickness. Thus, it is seen that the thickness of the first layer is small in relation to the thickness of the underlying base web.

[0047] FIG. 5 is a schematic view of a multiple stage printing apparatus. With reference to the above-description for multiple stage printing, FIG. 5 illustrates a reel 40, first gravure printing station 42, second gravure printing station 44, third gravure printing station 46, collection reel 48, rollers 50, impression cylinder 52, backing roller 54, nips 56, reservoir 58, pump 60, heat exchanger 62, applicator 64, bath 66, collector 67, drain 68, doctor blade 70, adjustment cylinders 72, and idler roller 74. In FIG. 5, features of the first gravure printing station 42 contain reference numerals with the suffix "a", corresponding features of the second gravure printing station 44 contain the same reference numeral with the suffix "b", and corresponding features of the third gravure printing station 46 contain the same reference numeral with the suffix "c".

EXAMPLES

[0048] The following examples are intended to be non-limiting and merely illustrative. Cigarettes with five different wrappers (i.e., wrappers with five different banded region configurations), were tested for ignition propensity ("IP") and self-extinguishment ("SE") at 0° (horizontal). The base web of each of the wrappers had a permeability of 33 CORESTA and basis weight of 25 g/m². As used herein "IP" refers to total burn through of a cigarette. Accordingly, an IP value of 0% indicates that 0% of the cigarettes tested exhibited total burn through, an IP value of 2.5% indicates that 2.5% of the cigarettes tested exhibited total burn through, and an IP value of 5% indicates that 5% of the cigarettes tested exhibited

EP 2 457 453 A1

total burn through. As used herein "SE" refers to self-extinguishment under free burn conditions. Thus, for example, an SE value of 95% indicates that 95% of the cigarettes tested exhibited self-extinguishment under free burn conditions, while an SE value of 20% indicates that 20% of the cigarettes tested exhibited self-extinguishment under free burn conditions.

5

Table 1

10

15

Wrapper	Banded Region Configuration*	Total Banded Region Width	IP Run 1	IP Run 2	IP Run 3	IP Avg.	SE @ 0°
A	Control	6 mm	0%	0%	0%	0%	95%
B	3-1-3	7 mm	0%	2.5%	0%	0.8%	60%
C	3-2-3	8 mm	0%	0%	5%	1.7%	25%
D	2-2-2	6 mm	2.5%	0%	0%	0.8%	45%
E	2-1-2-1-2	8 mm	2.5%	2.5%	2.5%	2.5%	20%

* Numbers refer to zone widths in mm (see Tables 2-5, below)

20

[0049] Referring to Table 1, wrapper A was a control, comprising a continuous, solid 6mm printed banded region, having an add-on rate of 5.5x. As used herein, an add-on rate of 5.5x results in 8 g/m² to 9 g/m² of add-on material on a dry weight basis, and a basis weight of 26.5 g/m² for 6 mm banded regions with a 27 mm phase (i.e., the spacing from the leading edge of a banded region to the leading edge of the next banded region) applied to a base web with a basis weight of 25 g/m².

25

Table 2 - Details of Wrapper B

30

	Zone 1	Zone 2	Zone 3
Width	3 mm	1 mm	3 mm
Layers of Add-on Material	2	1	2
Add-on Rate Per Layer	1.5x/4x	1.5x/0	1.5x/4x
Total Add-on Material	5.5x	1.5x	5.5x

35

Table 3 - Details of Wrapper C

40

	Zone 1	Zone 2	Zone 3
Width	3mm	2mm	3 mm
Layers of Add-on Material	2	1	2
Add-on Rate Per Layer	1.5x/4x	1.5x/0	1.5x/4x
Total Add-on Material	5.5x	1.5x	5.5x

45

Table 4 - Details of Wrapper D

50

55

	Zone 1	Zone 2	Zone 3
Width	2 mm	2 mm	2 mm
Layers of Add-on Material	2	2	2
Add-on Rate Per Layer	1.5x/4x	1.5x/2x	1.5x/4x
Total Add-on Material	5.5x	3.5x	5.5x

EP 2 457 453 A1

Table 5 - Details of Wrapper E

	Zone 1	Zone 2	Zone 3	Zone 4	Zone 5
Width	2 mm	1 mm	2mm	1 mm	2 mm
Layers of Add-on Material	2	1	2	1	2
Add-on Rate Per Layer	1.5x/4x	1.5x/0	1.5x/4x	1.5x/0	1.5x/4x
Total Add-on Material	5.5x	1.5x	5.5x	1.5x	5.5x

[0050] As compared to control wrapper A, wrappers B-E exhibited the desired reduction in SE while maintaining IP (*i.e.*, without significantly increasing IP). In particular, wrapper B exhibited an improvement over control wrapper A, as evidenced by the decrease in SE average from 95% to 60%. Further, comparing wrappers B and D, it can be seen that by increasing the width of the second zone from 1 mm to 2 mm, the SE average decreased from 60% to 25% (while approximately maintaining the IP value). Thus, the width of the second zone is preferably greater than 1 mm, preferably about 1.5 mm or about 2 mm. While good results were also shown by wrapper C, which exhibited an SE average of 45%, the best results were shown by wrapper E, which exhibited an SE average of 20%.

[0051] It should be noted that wrapper E, having a banded region comprising first, second, third, fourth and fifth zones and which showed the best results, had 1 mm second and fourth zones of greater permeability. In contrast, wrapper B, having a banded region comprising just first, second and third zones, with a 1 mm second zone of a greater permeability, did not perform as well. Thus, wrappers having banded regions comprising just first, second and third zones preferably have wider zones of greater permeability (*i.e.*, about 1.5 mm or about 2 mm) than the zones of greater permeability of wrappers having banded regions comprising first, second, third, fourth and fifth zones.

[0052] The terms and phrases used herein are not to be interpreted with mathematical or geometric precision, rather geometric terminology is to be interpreted as meaning approximating or similar to the geometric terms and concepts. Terms such as "generally" are intended to encompass both precise meanings of the associated terms and concepts as well as to provide reasonable latitude which is consistent with form, function, and/or meaning.

[0053] While various embodiments have been described, it is to be understood that variations and modifications may be resorted to as will be apparent to those skilled in the art. For example, the embodiments are described as having slits preferably 1 mm to 2 mm wide; other embodiments could be constructed with slits 1 mm to 3 mm wide. Such variations and modifications are to be considered within the purview and scope of the claims appended hereto.

[0054] Further aspects of the invention are set out in the following numbered sections:

1. A wrapper of a smoking article, comprising:

a base web; and
at least one transverse banded region comprising first, second and third zones,
said first and third zones comprising add-on material, which reduces permeability of said wrapper;
said first and third zones each having a width such that if either of said first or third zone were applied separately to wrappers of smoking articles, the smoking articles would exhibit statistically significant occurrences of total burn through and statistically few or no occurrences of self-extinguishment under free burn conditions;
the sum of said widths of said first and third zones being such that if the first and third zones were applied to wrappers of smoking articles as a single continuous band, the smoking articles would exhibit statistically few or no occurrences of total burn through and statistically significant occurrences of self-extinguishment under free burn conditions,
said first and third zones being separated by said second zone,
said wrapper having greater permeability along said second zone than along said first and third zones, said second zone having a width less than either width of said first and third zones, so that lit smoking articles comprising said first, second and third zones exhibit statistically reduced occurrences of self-extinguishment under free burn conditions, as compared to smoking articles comprising wrappers whereon the first and third zones are applied as a single continuous band, while maintaining statistically few or no occurrences of total burn through.

2. A wrapper according to section 1 wherein the first and third zones have a greater basis weight in grams per square meter than the second zone.

3. A wrapper according to section 1 or 2 wherein the basis weight in grams per square meter of the first and third zones is at least twice the basis weight in grams per square meter of the second zone.

4. A wrapper according to section 1, 2 or 3 wherein the second zone comprises a gap.

5. A wrapper according to any of sections 1 to 4 wherein the wrapper comprises iron oxide at the location of the second zone.

6. A wrapper according to any of sections 1 to 5 wherein the first and third zones comprise add-on material which is uniform across each of the first and third zones.

5 7. A wrapper according to any of sections 1 to 6 wherein the at least one transverse banded region comprises a first printed layer contacting the base web and a second printed layer on the first printed layer.

8. A wrapper according to any of sections 1 to 7 wherein the first and third zones each comprise at least three or four printed layers.

10 9. A wrapper of a smoking article, comprising:

a base web; and
at least one transverse banded region comprising first, second and third zones on the base web,

15 wherein the first and third zones are outward of the second zone, and
wherein the second zone has a greater permeability compared to the first and third zones.

10. A wrapper according to any of sections 9 wherein non-banded areas of the base web are not printed.

11. A wrapper of a smoking article, comprising:

20 a base web; and
at least one transverse banded region comprising first, second and third zones on the base web,

wherein the first and third zones are outward of the second zone,
wherein the second zone has a greater permeability compared to the first and third zones, ; and wherein the second zone and the first and third zones comprise add-on material.

25 12. A smoking article comprising the wrapper of any of sections 1 to 11, 9.

13. A method of making a banded wrapper of a smoking article, comprising:

30 supplying a base web; and
forming at least one transverse banded region comprising first, second and third zones on the base web;

wherein the first and third zones are outward of the second zone,
wherein the second zone has a greater permeability compared to the first and third zones, and wherein at least the first and third zones are formed from an add-on material free of fillers.

35 14. A method according to section 13 comprising forming at least the first and third zones by printing a first printed layer of add-on material on the base web.

15. A method according to section 13 or 14 comprising adding less add-on material in the second zone than the first and third zones.

16. A method according to section 13, 14 or 15 wherein the first and third zones have a greater basis weight in grams per square meter than the second zone.

40 17. A method according to section 16 wherein the basis weight in grams per square meter of the first and third zones is at least twice the basis weight in grams per square meter of the second zone.

18. A method according to any of sections 13 to 17 comprising forming the second zone and the first and third zones by printing a first printed layer of add-on material on the base web.

45 19. A method according to any of sections 13 to 18 wherein the at least one transverse banded region is formed by printing an occlusive material on the base web.

20. A method according to section 19 to wherein the printing comprises:

50 heating the occlusive material;
applying the heated occlusive material to a patterned gravure cylinder;
contacting the advancing wrapper with the patterned gravure cylinder; and
gelling the occlusive material by contact with the wrapper surface so that the occlusive material does not disrupt planarity of the wrapper.

55 21. A wrapper with slit banded regions comprises first, second, third, fourth and fifth zones, wherein the second and fourth zones have greater permeability than the first, third and fifth zones, which comprise add-on material.

22. A method of reducing the effect on at least one smoke constituent when adding a banded region to an existing design of a smoking article, said method comprising the step of adding an intermediate zone of increased permeability to said banded region.

Claims

1. A wrapper of a smoking article comprising:

5 a base web; and
a transverse banded region of add-on material, the transverse banded region sufficient to cause extinguishment of smoking articles comprising the transverse banded region when left upon a substrate,
the wrapper further comprising at least one air permeable second, intermediate zone along the transverse
10 banded region defining first and third zones of add-on material, the widths of the first, second and third zones being substantially equal, such that the occurrences of self-extinguishments of smoking articles comprising the said wrapper is statistically reduced over those without the second zone.

2. A wrapper according to claim 1 in which the width of each of the first, second and third zones is about 2 mm.

15 3. A wrapper according to claim 1 or 2 wherein the second zone comprises a gap.

4. A wrapper according to claim 1 or 2 wherein the second zone comprises a single printed layer and the region of add-on material comprises at least two printed layers.

20 5. A wrapper according to any preceding claim wherein non-banded areas of the base web are not printed.

6. A wrapper according to any preceding claim in which:

25 the zones each have a width such that if either of the first or third zone were applied separately to wrappers of smoking articles, the smoking articles would exhibit statistically significant occurrences of total burn through and statistically few or no occurrences of self-extinguishment under free burn conditions; and
the sum of the widths of the first and third zones is such that if the first and third zones were applied to wrappers of smoking articles as a single continuous band, the smoking articles would exhibit statistically few or no occurrences of total burn through and statistically significant occurrences of self-extinguishment under free burn
30 conditions.

7. A wrapper according to any preceding claim wherein the first and third zones have a greater basis weight in grams per square meter than the second zone, preferably wherein the basis weight in grams per square meter of the first and third zones is at least twice the basis weight in grams per square meter of the second zone.

35 8. A wrapper according to any preceding claim wherein the wrapper comprises iron oxide at the location of the second zone.

9. A wrapper according to any preceding claim wherein the first and third zones comprise add-on material which is uniform across each of the first and third zones.

40 10. A wrapper according to any preceding claim wherein the at least one transverse banded region comprises a first printed layer contacting the base web and a second printed layer on the first printed layer.

45 11. A wrapper according to any preceding claim wherein the first and third zones each comprise at least three or four printed layers.

12. A smoking article comprising a wrapper according to any preceding claim.

50 13. A method of making a banded wrapper of a smoking article, comprising:

supplying a base web; and
forming at least one transverse banded region comprising first and third zones and an intermediate second zone on the base web,

55 wherein the first and third zones are outward of the second zone,
wherein the second zone has a greater permeability compared to the first and third zones, wherein at least the first and third zones are formed from an add-on material free of fillers and wherein the zones are formed so that widths

of the first, second and third zones are substantially equal.

5 14. A method according to claim 13 wherein the zones are formed so that widths of the first, second and third zones are each about 2 mm.

15. A method according to claim 13 or 14 comprising forming at least the first and third zones by printing a first printed layer of add-on material on the base web.

10 16. A method according to claim 13, 14 or 15 comprising adding less add-on material in the second zone than the first and third zones.

15 17. A method according to any of claims 13 to 16 wherein the first and third zones have a greater basis weight in grams per square meter than the second zone, preferably wherein the basis weight in grams per square meter of the first and third zones is at least twice the basis weight in grams per square meter of the second zone.

18. A method according to any of claims 13 to 17 comprising forming the second zone and the first and third zones by printing a first printed layer of add-on material on the base web.

20 19. A method according to any of claims 13 to 18 wherein the at least one transverse banded region is formed by printing an occlusive material on the base web.

25 20. A method according to claim 19 wherein the printing comprises:

heating the occlusive material;

25 applying the heated occlusive material to a patterned gravure cylinder;

contacting the advancing wrapper with the patterned gravure cylinder; and

gelling the occlusive material by contact with the wrapper surface so that the occlusive material does not disrupt planarity of the wrapper.

30

35

40

45

50

55

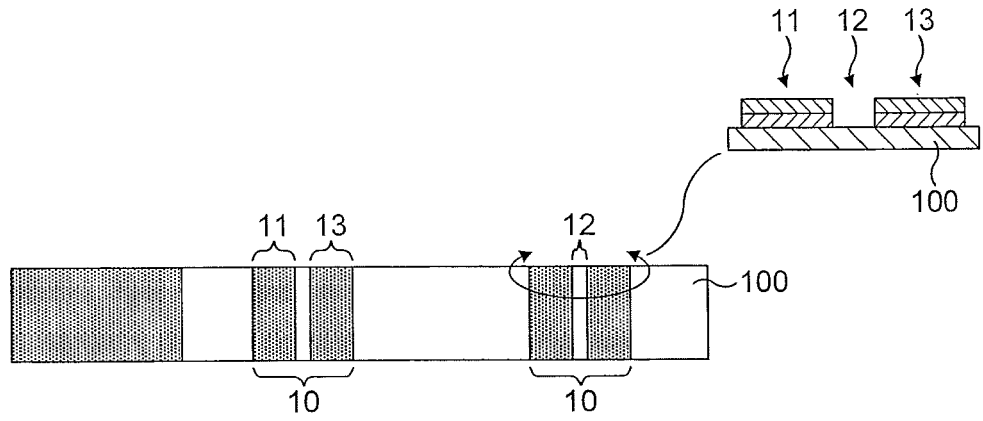

FIG. 1

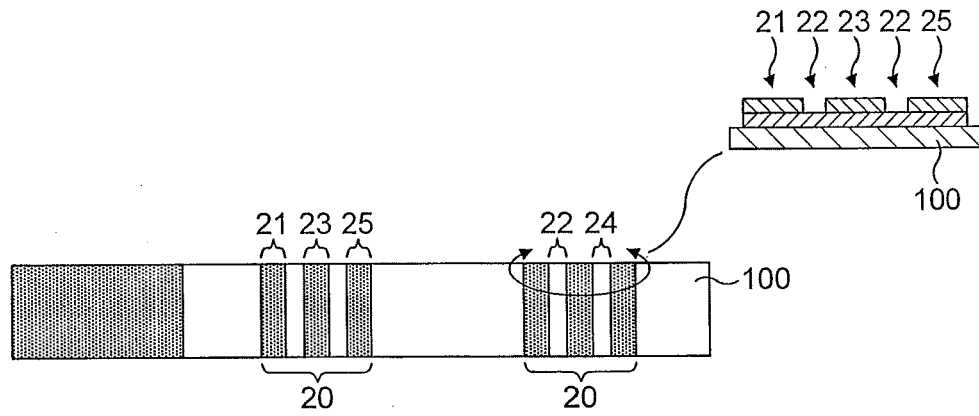

FIG. 2

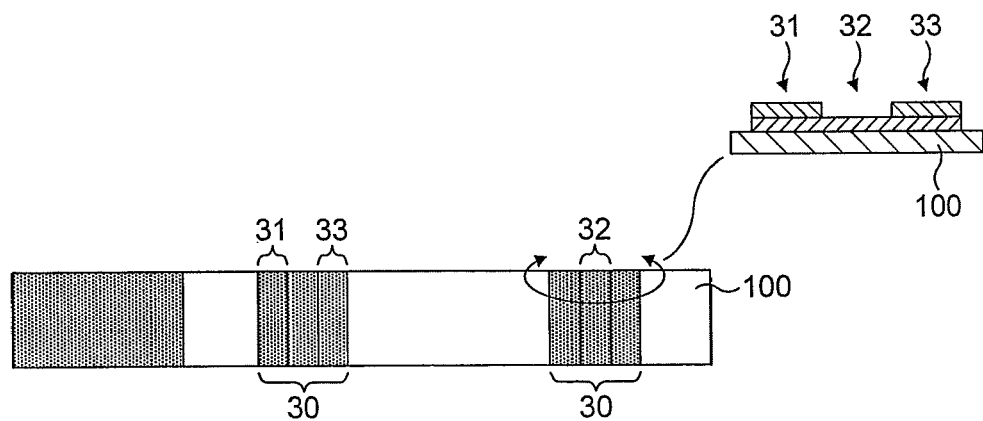

FIG. 3

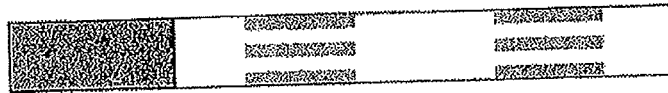

FIG. 4

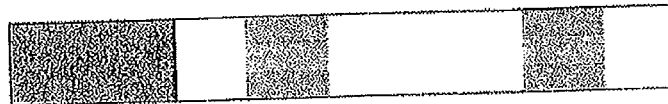
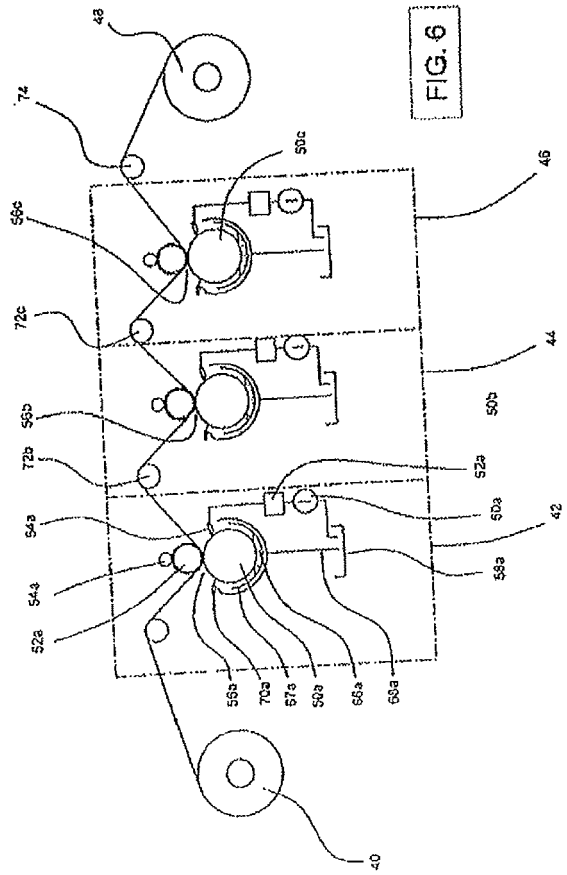

FIG. 5





EUROPEAN SEARCH REPORT

Application Number
EP 12 15 6227

DOCUMENTS CONSIDERED TO BE RELEVANT			
Category	Citation of document with indication, where appropriate, of relevant passages	Relevant to claim	CLASSIFICATION OF THE APPLICATION (IPC)
X	US 4 077 414 A (BAKER RICHARD ROLAND ET AL) 7 March 1978 (1978-03-07)	1-3,5,7-9,12-15,17,19	INV. A24D1/02
Y	* column 1, line 65 - column 2, line 18; figures; examples *	4,6,10,11,16,18,20	
X	US 2003/136420 A1 (KRAKER THOMAS A [US]) 24 July 2003 (2003-07-24)	1,3,5,7,9,12,13,15,17-20	
Y	* paragraph [0007] - paragraph [0020]; claims; figures *		
Y	US 2004/099280 A1 (STOKES CYNTHIA STEWART [US] ET AL) 27 May 2004 (2004-05-27)	4,6,10,11,16,18,20	
Y	* paragraph [0001]; figures; examples *		
A	EP 1 234 514 A (LORILLARD LICENSING COMPANY LL [US]) 28 August 2002 (2002-08-28)	1-20	TECHNICAL FIELDS SEARCHED (IPC) A24D B05C D21H
A	* the whole document *		
A	US 2005/172977 A1 (JADOT PAUL [US] ET AL) 11 August 2005 (2005-08-11)	1-20	
A	* the whole document *		
A	WO 2005/002370 A (PHILIP MORRIS USA INC [US]; LI PING [US]; GEDEVANISHVILI SHALVA [US];) 13 January 2005 (2005-01-13)	8	
A	* paragraph [0024] - paragraph [0025]; figures *		

The present search report has been drawn up for all claims			
Place of search		Date of completion of the search	Examiner
Munich		3 April 2012	Marzano Monterosso
CATEGORY OF CITED DOCUMENTS		T : theory or principle underlying the invention E : earlier patent document, but published on, or after the filing date D : document cited in the application L : document cited for other reasons & : member of the same patent family, corresponding document	
X : particularly relevant if taken alone Y : particularly relevant if combined with another document of the same category A : technological background O : non-written disclosure P : intermediate document			

1
EPO FORM 1503 03.82 (P04C01)

ANNEX TO THE EUROPEAN SEARCH REPORT
ON EUROPEAN PATENT APPLICATION NO.

EP 12 15 6227

This annex lists the patent family members relating to the patent documents cited in the above-mentioned European search report. The members are as contained in the European Patent Office EDP file on
The European Patent Office is in no way liable for these particulars which are merely given for the purpose of information.

03-04-2012

Patent document cited in search report		Publication date	Patent family member(s)	Publication date
US 4077414	A	07-03-1978	AU 500814 B2	31-05-1979
			AU 8786375 A	30-06-1977
			BE 837440 A1	03-05-1976
			BR 7600035 A	03-08-1976
			CA 1035230 A1	25-07-1978
			CH 604576 A5	15-09-1978
			DE 2559071 A1	15-07-1976
			DK 5576 A	10-07-1976
			FI 753635 A	10-07-1976
			GB 1524211 A	06-09-1978
			JP 1176698 C	14-11-1983
			JP 51095197 A	20-08-1976
			JP 58005662 B	01-02-1983
			NL 7600147 A	13-07-1976
			US 4077414 A	07-03-1978
ZA 7507980 A	29-12-1976			

US 2003136420	A1	24-07-2003	AT 424122 T	15-03-2009
			BR 0307111 A	28-12-2004
			CA 2467767 A1	31-07-2003
			CN 1612700 A	04-05-2005
			EP 1482815 A1	08-12-2004
			ES 2321597 T3	09-06-2009
			HK 1077713 A1	02-11-2007
			JP 4672261 B2	20-04-2011
			JP 2005514939 A	26-05-2005
			JP 2011069040 A	07-04-2011
			MX PA04007017 A	14-10-2004
			NZ 532956 A	30-11-2006
			PT 1482815 E	05-05-2009
			RU 2313264 C2	27-12-2007
			US 2003136420 A1	24-07-2003
US 2004255966 A1	23-12-2004			
WO 03061410 A1	31-07-2003			

US 2004099280	A1	27-05-2004	US 2004099280 A1	27-05-2004
			US 2006124146 A1	15-06-2006

EP 1234514	A	28-08-2002	AT 468765 T	15-06-2010
			AU 2002240293 B2	09-10-2008
			CA 2442615 A1	06-09-2002
			EP 1234514 A2	28-08-2002
			ES 2346129 T3	11-10-2010
			HK 1048420 A1	28-01-2011
			NZ 528529 A	31-08-2006
			US 2002179105 A1	05-12-2002

EPO FORM P0459

For more details about this annex : see Official Journal of the European Patent Office, No. 12/82

**ANNEX TO THE EUROPEAN SEARCH REPORT
ON EUROPEAN PATENT APPLICATION NO.**

EP 12 15 6227

This annex lists the patent family members relating to the patent documents cited in the above-mentioned European search report. The members are as contained in the European Patent Office EDP file on
The European Patent Office is in no way liable for these particulars which are merely given for the purpose of information.

03-04-2012

Patent document cited in search report	Publication date	Patent family member(s)	Publication date
		US 2003164173 A1	04-09-2003
		WO 02067704 A1	06-09-2002

US 2005172977	A1	11-08-2005	NONE

WO 2005002370	A	13-01-2005	
		AR 045429 A1	26-10-2005
		AT 379978 T	15-12-2007
		AU 2004246883 A1	23-12-2004
		AU 2004253467 A1	13-01-2005
		BR PI0411362 A	25-07-2006
		BR PI0411445 A	18-07-2006
		CA 2526424 A1	23-12-2004
		CA 2527359 A1	13-01-2005
		CN 1805696 A	19-07-2006
		CN 1806080 A	19-07-2006
		DE 602004010511 T2	27-11-2008
		EP 1635657 A2	22-03-2006
		EP 1635658 A2	22-03-2006
		ES 2297480 T3	01-05-2008
		HK 1084163 A1	25-07-2008
		IL 172274 A	01-09-2009
		JP 4637099 B2	23-02-2011
		JP 2006526996 A	30-11-2006
		JP 2007511204 A	10-05-2007
		KR 20060026870 A	24-03-2006
		KR 20060026875 A	24-03-2006
		MA 27877 A1	02-05-2006
		MA 27878 A1	02-05-2006
		MX PA05013556 A	05-04-2006
		MX PA05013559 A	05-04-2006
		NO 327251 B1	25-05-2009
		PT 1635658 E	21-02-2008
		UY 28363 A1	31-12-2004
		WO 2004110189 A2	23-12-2004
		WO 2005002370 A2	13-01-2005
		ZA 200509378 A	27-08-2008
		ZA 200509578 A	29-11-2006

EPO FORM P0459

For more details about this annex : see Official Journal of the European Patent Office, No. 12/82

REFERENCES CITED IN THE DESCRIPTION

This list of references cited by the applicant is for the reader's convenience only. It does not form part of the European patent document. Even though great care has been taken in compiling the references, errors or omissions cannot be excluded and the EPO disclaims all liability in this regard.

Patent documents cited in the description

- US 5997691 A [0011]
- US 6596125 B [0011]
- US 70796405 P [0028]