



US00D759596S

(12) **United States Design Patent**  
**Byrne et al.**

(10) **Patent No.:** **US D759,596 S**

(45) **Date of Patent:** **\*\* Jun. 21, 2016**

(54) **ELECTRICAL POWER UNIT FOR A WORK SURFACE**

(71) Applicants: **Norman R. Byrne**, Ada, MI (US);  
**Timothy J. Warwick**, Sparta, MI (US)

(72) Inventors: **Norman R. Byrne**, Ada, MI (US);  
**Timothy J. Warwick**, Sparta, MI (US)

(\*\*) Term: **14 Years**

(21) Appl. No.: **29/517,408**

(22) Filed: **Feb. 12, 2015**

(51) **LOC (10) Cl.** ..... **13-03**

(52) **U.S. Cl.**  
USPC ..... **D13/137.2**

(58) **Field of Classification Search**  
USPC ..... D13/137.1–137.4, 138.1–138.2,  
D13/139.1–139.8, 110, 152, 171, 156, 199;  
174/480, 483; 439/131; 307/117;  
D14/305; 1/1; 361/611  
CPC ..... A47B 21/06; H02G 3/185  
See application file for complete search history.

(56) **References Cited**

**U.S. PATENT DOCUMENTS**

676,622 A	6/1901	Gochnauer
2,811,574 A	10/1957	Guerrero
2,861,857 A	11/1958	Lee
3,131,512 A	5/1964	MacLeod, Jr.
3,353,137 A	11/1967	Miller
3,433,886 A	3/1969	Myers
3,622,684 A	11/1971	Press
3,646,244 A	2/1972	Cole
3,794,956 A	2/1974	Dubreuil
D233,729 S	11/1974	De Forrest
3,892,095 A	7/1975	Vankuik
3,972,579 A	8/1976	Kohaut
3,992,070 A	11/1976	Dunn
4,059,321 A	11/1977	Rasmussen
4,272,643 A	6/1981	Carroll
4,372,629 A	2/1983	Propst
4,551,198 A	11/1985	Wiley

4,551,577 A	11/1985	Byrne
4,747,788 A	5/1988	Byrne
4,792,881 A	12/1988	Wilson
4,828,513 A	5/1989	Morrison
4,967,041 A	10/1990	Bowman
4,984,982 A	1/1991	Brownlie
4,986,762 A	1/1991	Keith
5,023,396 A	6/1991	Bartee
5,114,365 A	5/1992	Thompson
5,122,069 A	6/1992	Brownlie
5,230,552 A	7/1993	Schipper
5,231,562 A	7/1993	Pierce
5,351,173 A	9/1994	Byrne

(Continued)

**OTHER PUBLICATIONS**

Co-pending and commonly-owned design U.S. Appl. No. 29/516,875, filed Feb. 6, 2015.

*Primary Examiner* — Holly Baynham

*Assistant Examiner* — Rhea Shields

(74) *Attorney, Agent, or Firm* — Gardner, Linn, Burkhardt & Flory, LLP

(57) **CLAIM**

The ornamental design for an electrical power unit for a work surface, as shown and described.

**DESCRIPTION**

FIG. 1 is a front perspective view of an electrical power unit for a work surface in an open configuration showing our new design; FIG. 2 is a rear perspective view thereof; FIG. 3 is a front elevation thereof; FIG. 4 is a rear elevation thereof; FIG. 5 is a top plan view thereof; FIG. 6 is a bottom plan view thereof; FIG. 7 is a left side elevation thereof; and, FIG. 8 is a right side elevation thereof. In the drawings, the broken lines are for the purpose of illustrating environment only and form no part of the claimed design.

**1 Claim, 7 Drawing Sheets**

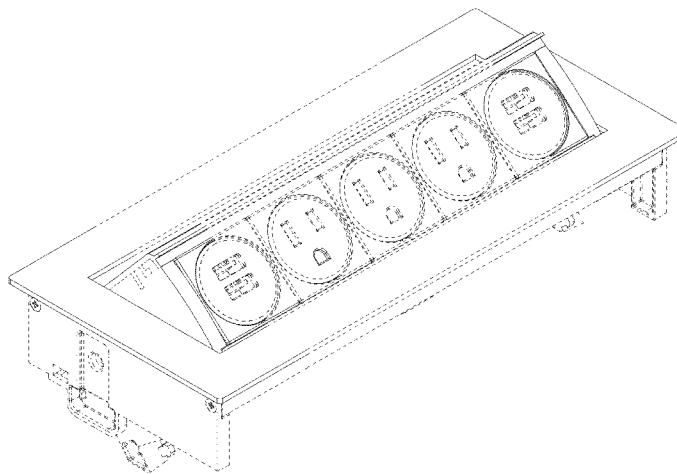

(56)

References Cited

U.S. PATENT DOCUMENTS

D353,363 S 12/1994 Toby  
 D355,890 S 2/1995 Lentz  
 5,387,761 A 2/1995 Simonis  
 5,516,298 A 5/1996 Smith  
 D370,622 S 6/1996 Byrne  
 D372,018 S 7/1996 Byrne  
 D375,292 S 11/1996 D'Amato  
 5,575,668 A 11/1996 Timmerman  
 5,705,772 A 1/1998 Brown  
 5,709,156 A 1/1998 Gevaert  
 D392,254 S 3/1998 Gevaert  
 5,757,668 A 5/1998 Zhu  
 D397,086 S \* 8/1998 Lin ..... D13/137.2  
 D405,051 S \* 2/1999 Byrne ..... D13/139.4  
 D405,052 S \* 2/1999 Byrne ..... D13/139.4  
 D406,103 S \* 2/1999 Byrne ..... D13/139.4  
 D407,374 S 3/1999 Byrne  
 D412,695 S \* 8/1999 Byrne ..... D13/139.4  
 D412,696 S \* 8/1999 Byrne ..... D13/139.4  
 D412,697 S \* 8/1999 Byrne ..... D13/139.4  
 D412,698 S \* 8/1999 Byrne ..... D13/139.4  
 D413,571 S \* 9/1999 Glass ..... D13/139.4  
 5,980,279 A 11/1999 Muller  
 D420,327 S 2/2000 Byrne  
 6,028,267 A 2/2000 Byrne  
 D437,827 S 2/2001 Gershfeld  
 D442,143 S \* 5/2001 Gershfeld ..... D13/139.4  
 D446,188 S \* 8/2001 Gershfeld ..... D13/139.4  
 6,290,518 B1 9/2001 Byrne  
 D449,819 S \* 10/2001 Gershfeld ..... D13/139.4  
 D454,541 S \* 3/2002 Gershfeld ..... D13/139.4  
 D455,123 S 4/2002 Gershfeld  
 D455,716 S 4/2002 Gershfeld  
 D456,357 S \* 4/2002 Gershfeld ..... D13/139.4  
 D457,137 S 5/2002 Gershfeld  
 D460,736 S 7/2002 Pincek et al.  
 D463,775 S \* 10/2002 Byrne ..... D13/139.4  
 D464,627 S \* 10/2002 Metcalf ..... D13/152  
 D465,201 S \* 11/2002 Gershfeld ..... D13/139.4  
 D466,868 S 12/2002 Gershfeld  
 D467,873 S \* 12/2002 Yu ..... D13/137.2  
 6,492,591 B1 \* 12/2002 Metcalf ..... A47B 21/06  
 174/480  
 D468,701 S \* 1/2003 Byrne ..... D13/156  
 D472,213 S 3/2003 Byrne  
 D473,525 S 4/2003 Pincek et al.  
 D475,016 S \* 5/2003 Gershfeld ..... D13/139.4  
 D477,280 S \* 7/2003 Gershfeld ..... D13/139.4  
 6,923,663 B2 8/2005 Oddsen  
 D512,964 S \* 12/2005 Kissinger ..... D13/139.4  
 D513,493 S \* 1/2006 Feldstein ..... D13/139.4  
 D516,513 S 3/2006 Kissinger et al.  
 7,045,706 B1 5/2006 Lincoln

7,053,296 B2 \* 5/2006 Drane ..... H02G 3/185  
 174/483  
 D524,310 S \* 7/2006 Kent ..... D13/147  
 D526,961 S 8/2006 Kissinger et al.  
 D534,495 S \* 1/2007 Gershfeld ..... D13/139.4  
 D535,257 S 1/2007 Byrne  
 7,163,409 B1 \* 1/2007 Chen ..... H01R 25/006  
 439/131  
 D537,039 S 2/2007 Pincek  
 7,183,501 B2 \* 2/2007 Bowman ..... H02G 3/185  
 174/480  
 D537,785 S 3/2007 Pincek  
 D549,656 S \* 8/2007 Hsiao ..... D13/139.8  
 D553,306 S \* 10/2007 Hansen ..... D13/139.4  
 D556,139 S 11/2007 Gershfeld  
 D569,863 S \* 5/2008 Feldstein ..... D14/305  
 7,407,392 B2 8/2008 Cooke et al.  
 D576,118 S \* 9/2008 Beilstein ..... D13/199  
 D579,873 S \* 11/2008 Gershfeld ..... D13/139.4  
 D591,682 S \* 5/2009 Lin ..... D13/139.2  
 D597,960 S 8/2009 Dinh et al.  
 D603,411 S \* 11/2009 Zonshine ..... D13/139.5  
 7,614,889 B1 11/2009 Black et al.  
 7,663,866 B2 \* 2/2010 Lee ..... H01R 13/652  
 307/117  
 D614,574 S 4/2010 Thommes  
 7,736,178 B2 6/2010 Byrne  
 D622,219 S 8/2010 Byrne  
 D626,069 S 10/2010 Byrne  
 D626,070 S 10/2010 Byrne  
 D635,921 S \* 4/2011 Sato ..... D13/139.4  
 D639,244 S 6/2011 Byrne  
 7,989,738 B2 8/2011 Byrne  
 D649,514 S 11/2011 Byrne  
 D657,315 S \* 4/2012 Feldstein ..... D13/139.4  
 D660,237 S 5/2012 Byrne  
 D665,355 S 8/2012 Byrne  
 D685,329 S \* 7/2013 Byrne ..... D13/139.4  
 8,482,252 B2 7/2013 Byrne  
 8,625,255 B2 \* 1/2014 Linnane ..... H02G 3/0608  
 361/611  
 D707,178 S 6/2014 Byrne et al.  
 D709,031 S \* 7/2014 Byrne ..... D13/139.4  
 D709,832 S 7/2014 Byrne et al.  
 D711,323 S 8/2014 Wardenburg  
 D715,740 S \* 10/2014 Byrne ..... D13/139.4  
 D716,232 S 10/2014 Byrne et al.  
 D721,330 S 1/2015 Byrne et al.  
 D730,834 S 6/2015 Byrne et al.  
 9,071,002 B2 \* 6/2015 Mazzullo ..... H01R 13/516  
 D736,159 S \* 8/2015 Byrne ..... D13/139.4  
 D741,266 S 10/2015 Byrne et al.  
 D741,267 S 10/2015 Byrne et al.  
 2004/0147147 A1 7/2004 Griepentrog  
 2004/0238197 A1 12/2004 Gates, II

\* cited by examiner

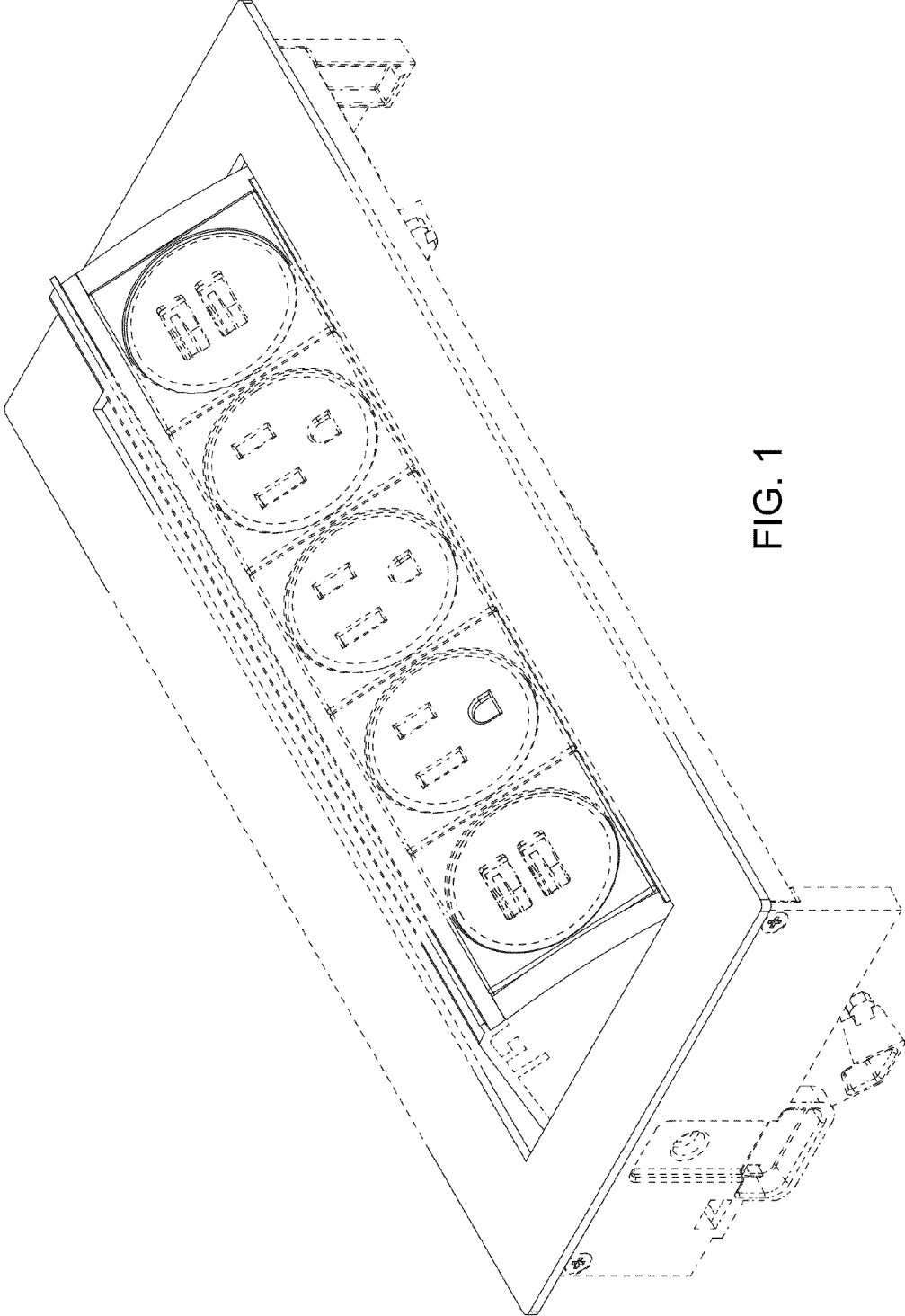

FIG. 1

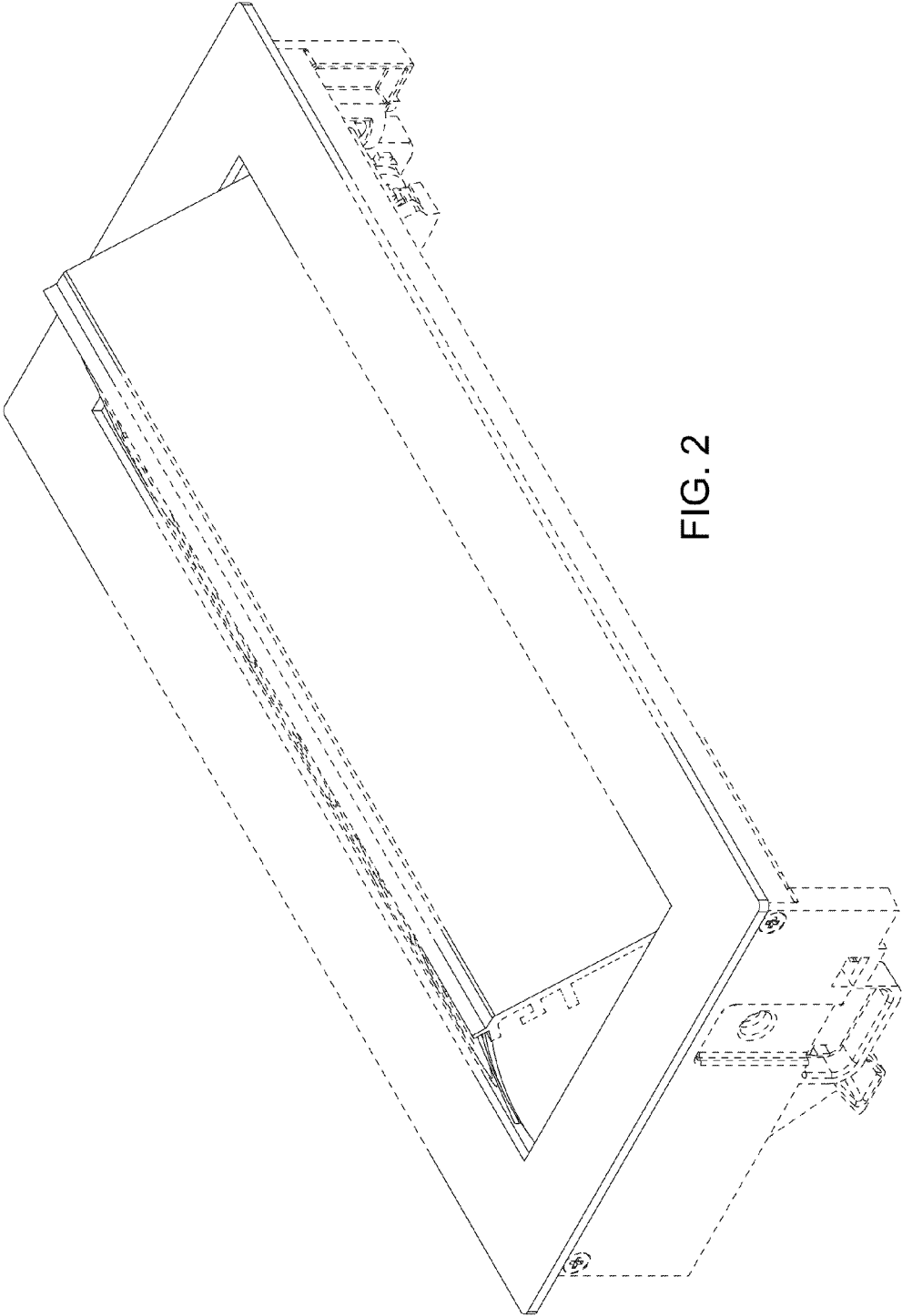

FIG. 2

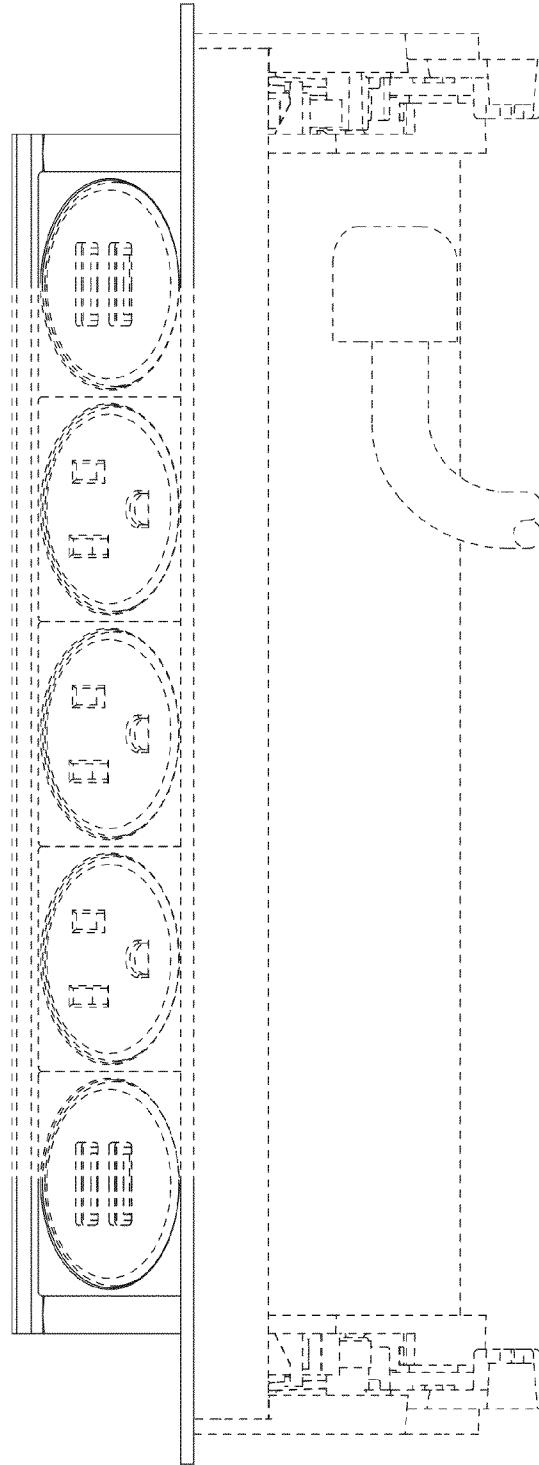

FIG. 3

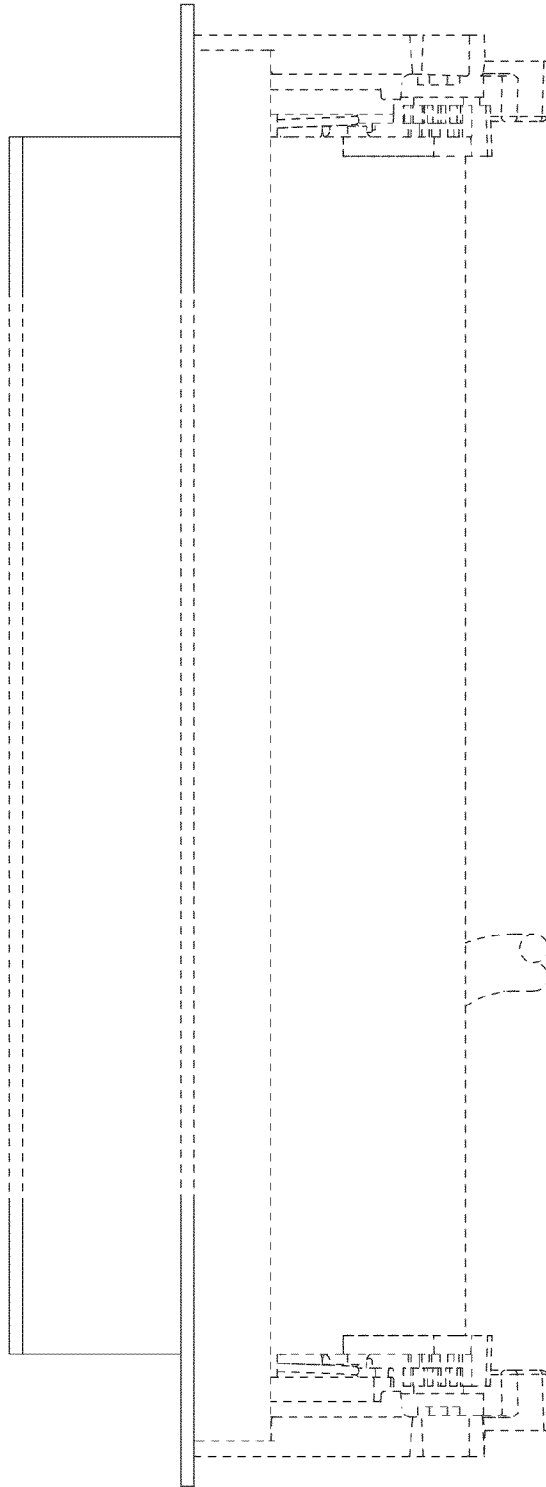

FIG. 4

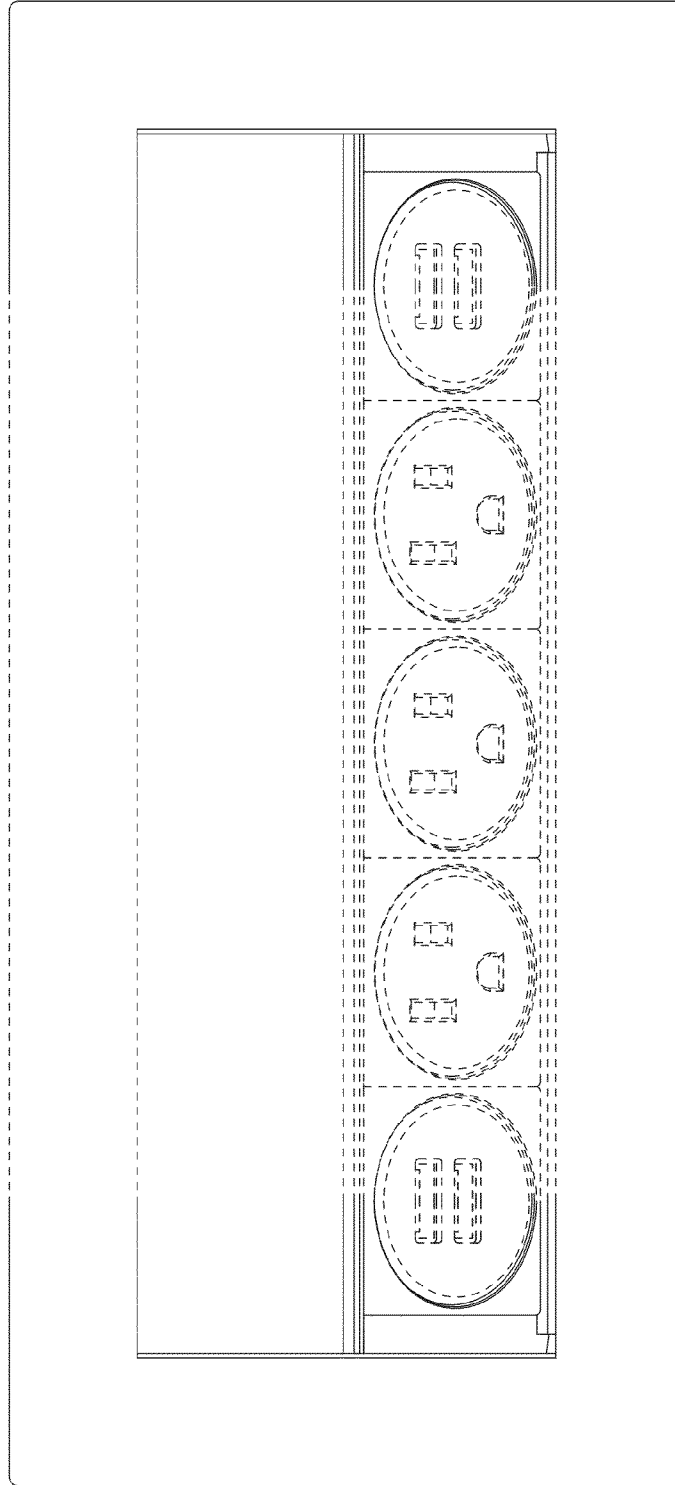

FIG. 5

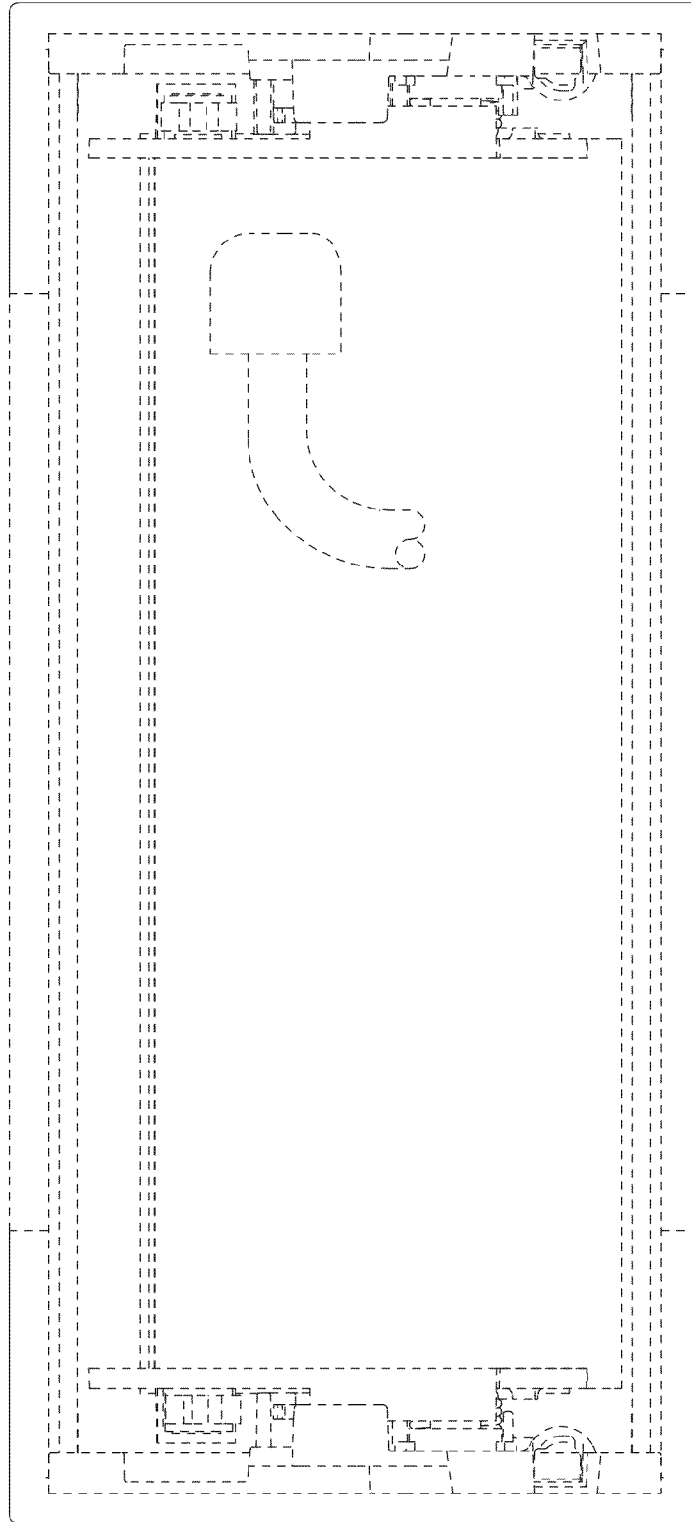

FIG. 6



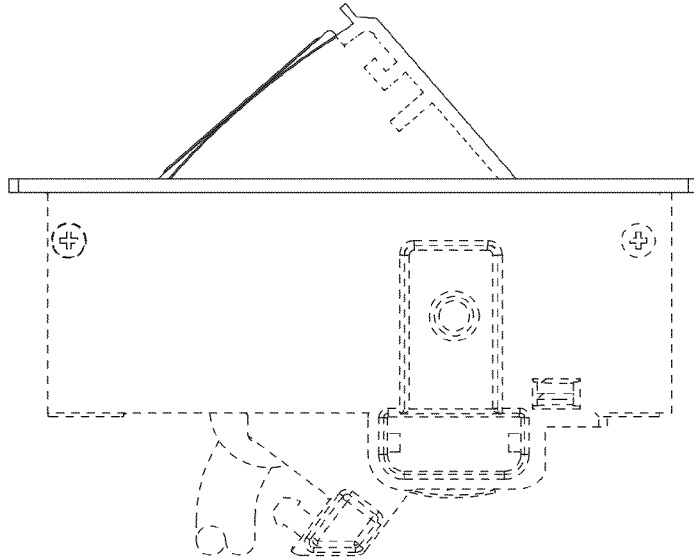

FIG. 7

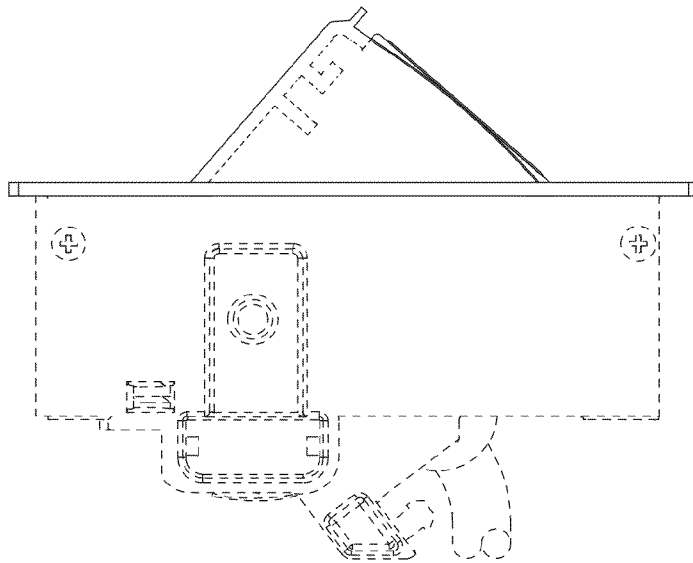

FIG. 8