



(19) **United States**

(12) **Patent Application Publication**

Kato

(10) **Pub. No.: US 2002/0041603 A1**

(43) **Pub. Date: Apr. 11, 2002**

(54) **CONTROL METHOD AND COMMUNICATION DEVICE**

Publication Classification

(51) **Int. Cl.⁷ H04J 3/22**

(52) **U.S. Cl. 370/465**

(75) **Inventor: Junji Kato, Tokyo (JP)**

(57) **ABSTRACT**

Correspondence Address:
**LERNER, DAVID, LITTENBERG,
KRUMHOLZ & MENTLIK
600 SOUTH AVENUE WEST
WESTFIELD, NJ 07090 (US)**

A power consumption required for communication between communication devices connected to a network constituted by an IEEE 1394 bus line is reduced. When communication in a synchronous communication mode and communication in an asynchronous communication mode can be performed, a power supply of a part (110) for a communication process in a synchronous communication mode is controlled independently of a power supply of a part (105, 106) for executing a communication process in an asynchronous communication mode. The power supply of the part (105, 106) for executing the communication process in the asynchronous communication mode is controlled independently of the power supply of the part (110) for executing the communication process in the synchronous communication mode.

(73) **Assignee: Sony Corporation**

(21) **Appl. No.: 09/870,047**

(22) **Filed: May 30, 2001**

(30) **Foreign Application Priority Data**

Jun. 20, 2000 (JP) P2000-185048

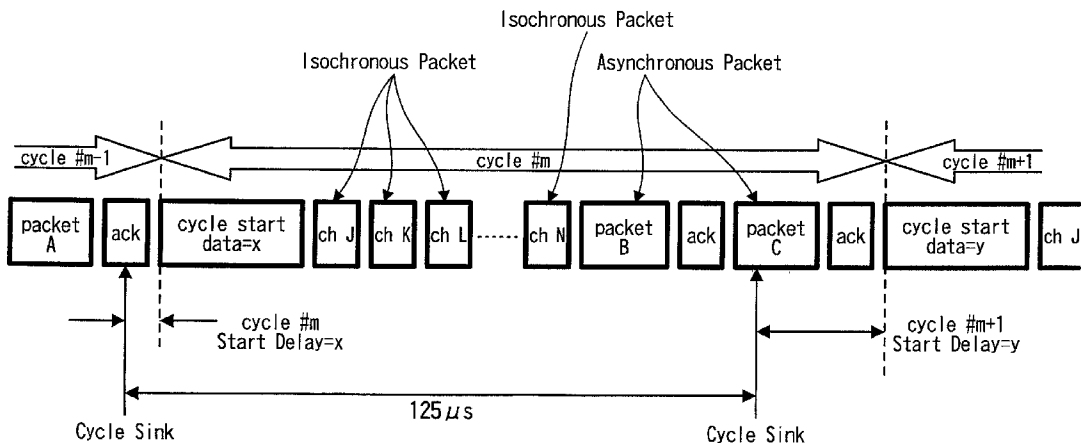
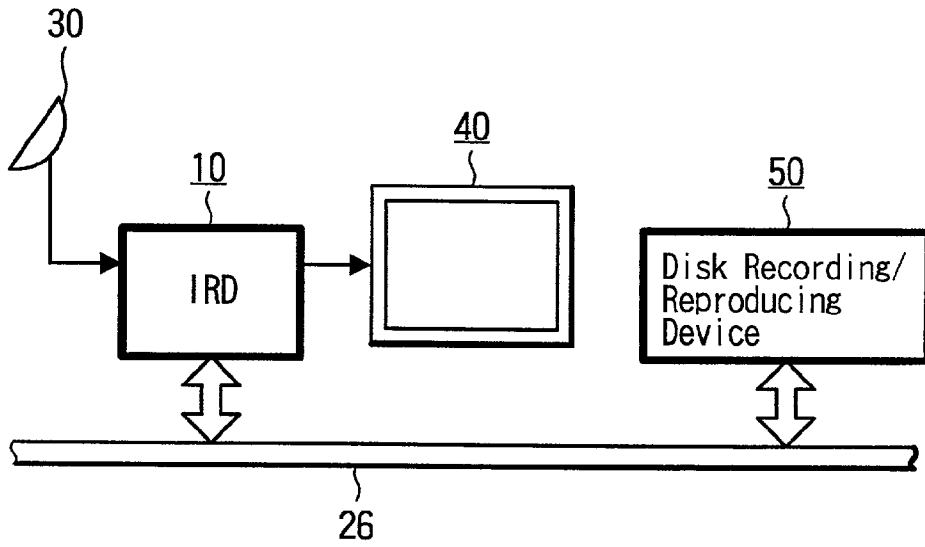

FIG. 1



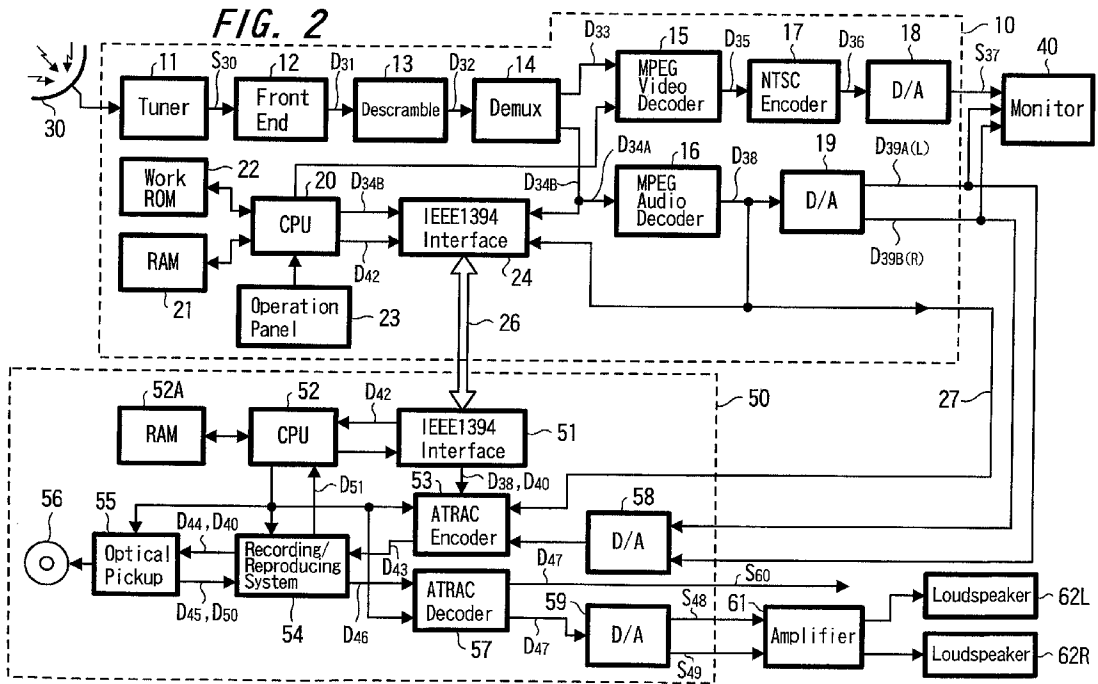

FIG. 3

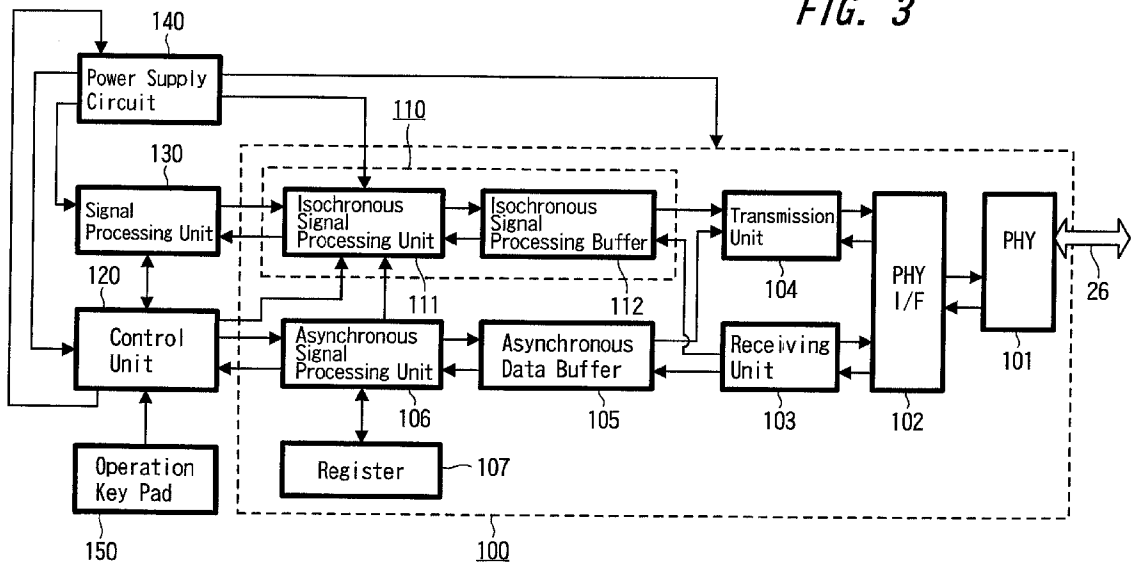

FIG. 4

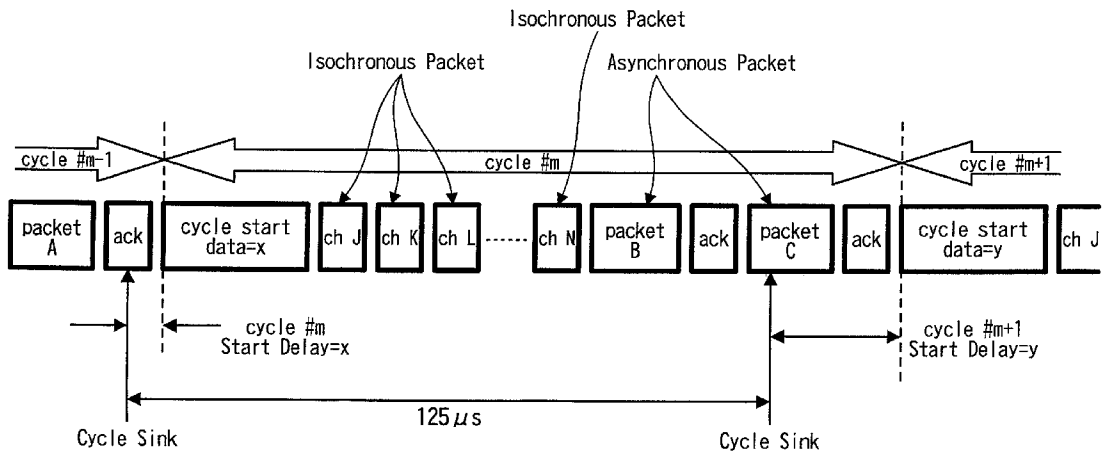

FIG. 5

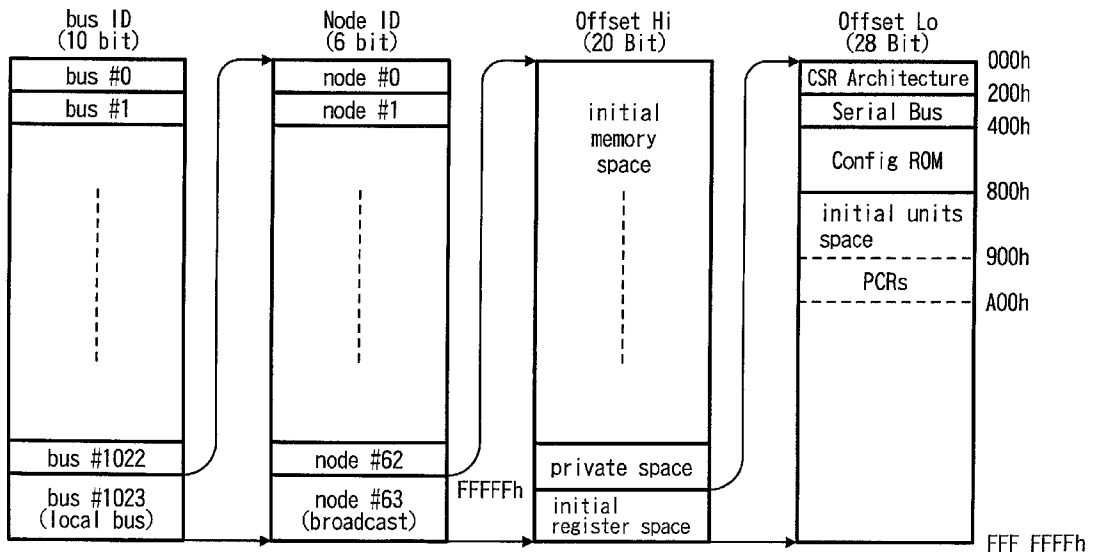

FIG. 6

Offset	Name	Operation
000h	State_Clear	State And Control Information
004h	State_Set	Set State_Clear Bit
008h	Node_IDs	Represent 16_Bit Node ID
00Ch	Reset_Start	Start Command Reset
018-01Ch	Split_Timeout	Regulate Maximum Time of Split
200h	Cycle_Time	Cycle Time
210h	Busy_Timeout	Regulate Limit of Retry
21Ch	Bus_Manager	Represent ID of Bus Manager
220h	Bandwidth_Available	Represent Band Which Can be Allocated to Isochronous Communication
224h-228h	Channels_Available	Represent Using States of Channels

FIG. 7

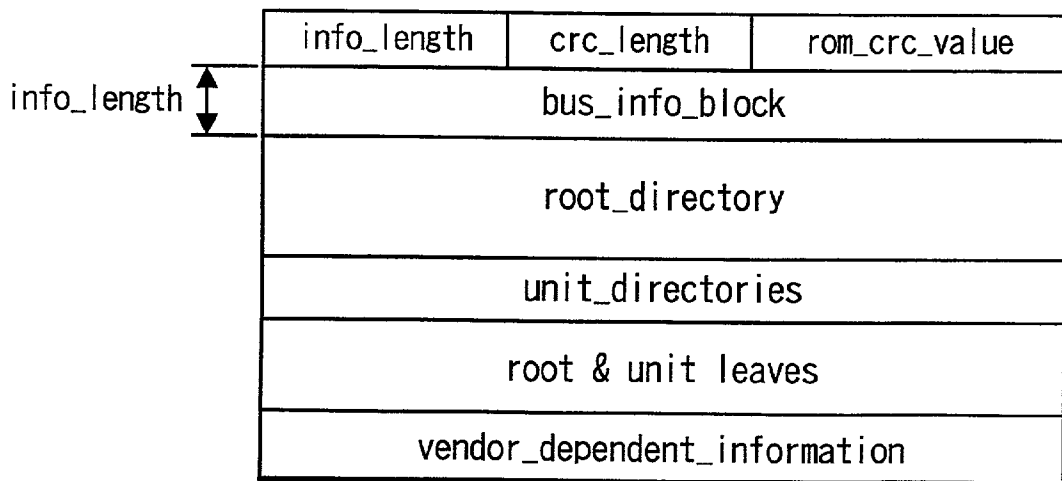

FIG. 8

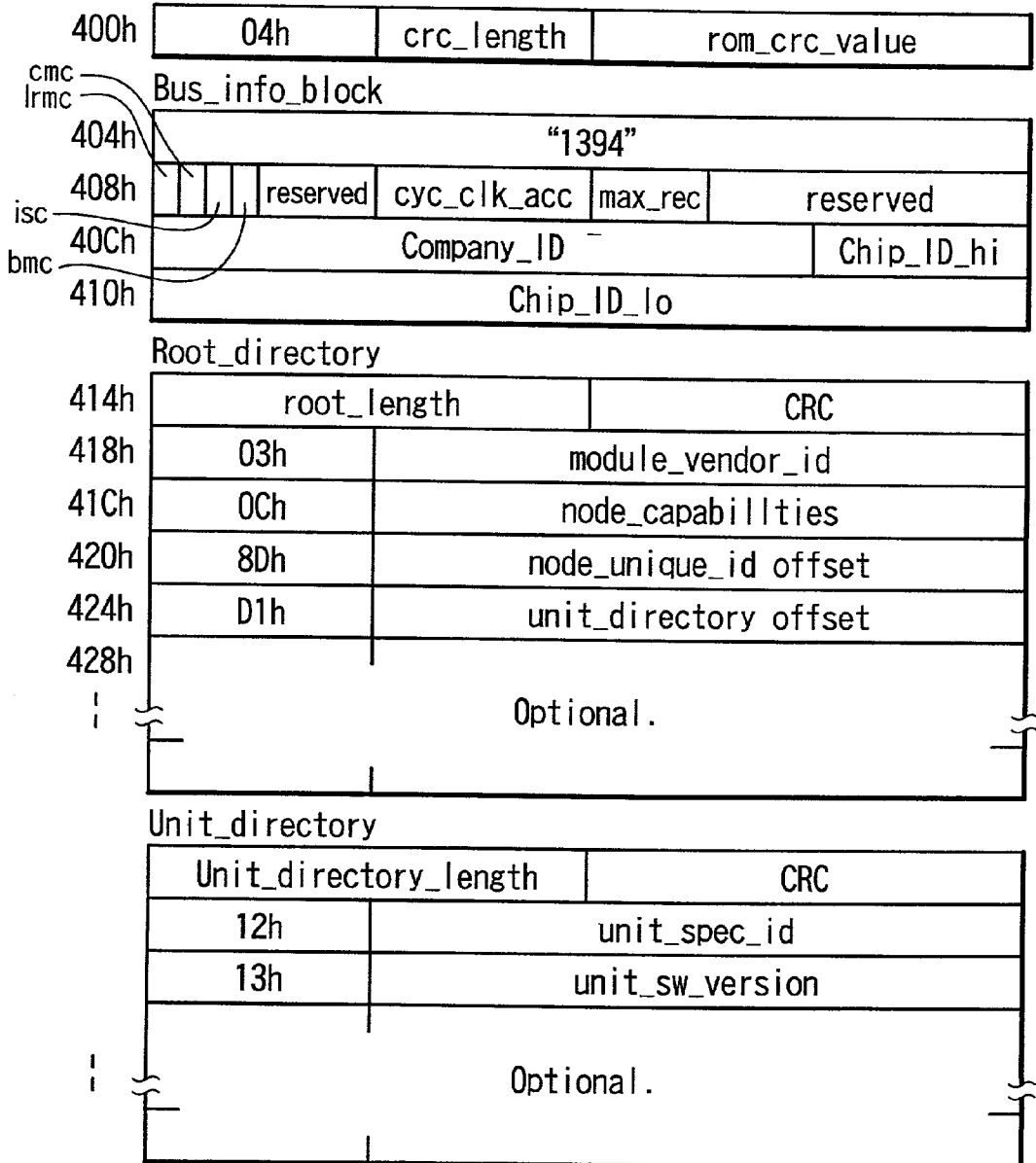

FIG. 9

900h	Output Master Plug Register
904h	Output Plug Control Register #0
908h	Output Plug Control Register #1
⋮	⋮
97Ch	Output Plug Control Register #30
980h	Input Master Plug Register
984h	Input Plug Control Register #0
988h	Input Plug Control Register #1
⋮	⋮
9FCh	Input Plug Control Register #30

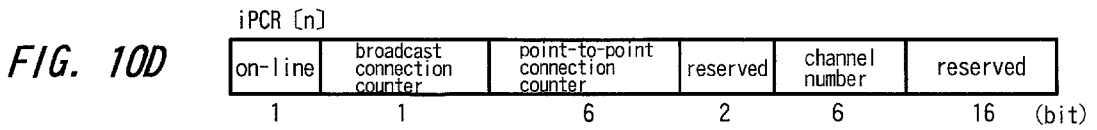
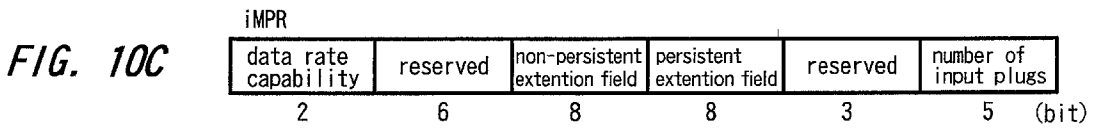
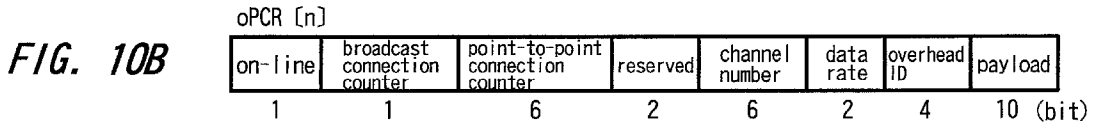
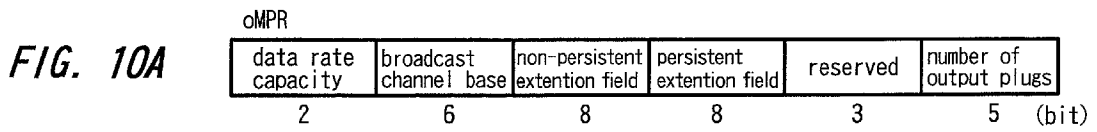

FIG. 11

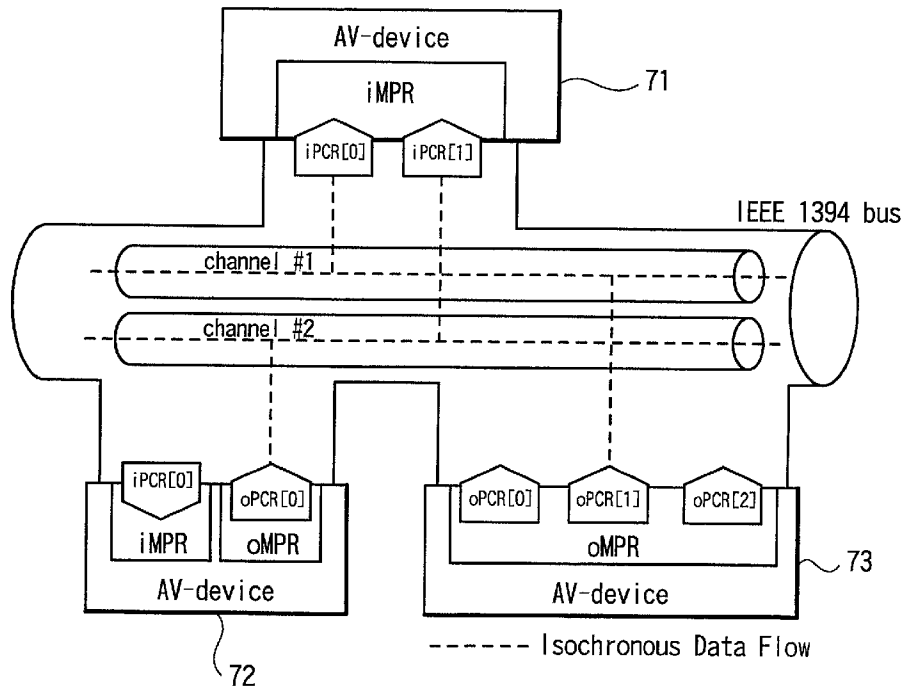

FIG. 12

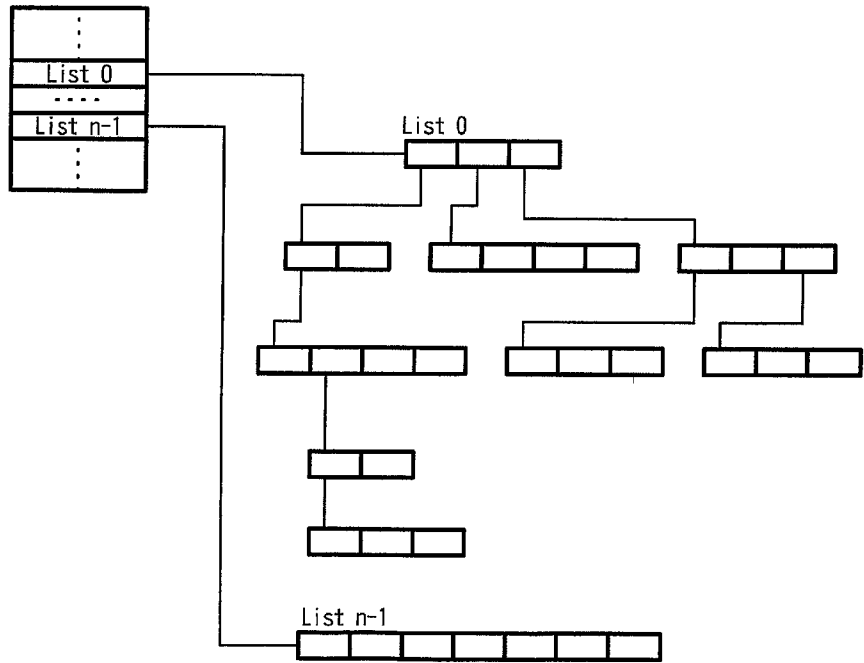

FIG. 13

The General Subunit Identifier Descriptor	
address	contents
00 00 ₁₆	descriptor_length
00 01 ₁₆	
00 02 ₁₆	generation_ID
00 03 ₁₆	size_of_list_ID
00 04 ₁₆	size_of_object_ID
00 05 ₁₆	size_of_object_position
00 06 ₁₆	number_of_root_object_lists(n)
00 07 ₁₆	
00 08 ₁₆	root_object_list_id_0
⋮	
⋮	⋮
⋮	root_object_list_id_n-1
⋮	
⋮	subunit_dependent_length
⋮	
⋮	subunit_dependent_information
⋮	
⋮	manufacturer_dependent_length
⋮	
⋮	manufacturer_dependent_information
⋮	
⋮	

FIG. 14

generation_ID values	
generation_ID	meaning
00 ₁₆	Data structures and command sets as specified in the AV/C General Specification, version 3.0
all others	reserved for future specification

FIG. 15

List ID Value Assignment Ranges	
range of values	list definition
0000 ₁₆ -0FFF ₁₆	reserved
1000 ₁₆ -3FFF ₁₆	subunit-type dependent
4000 ₁₆ -FFFF ₁₆	reserved
1 000 ₁₆ -max list ID value	subunit-type dependent

FIG. 16

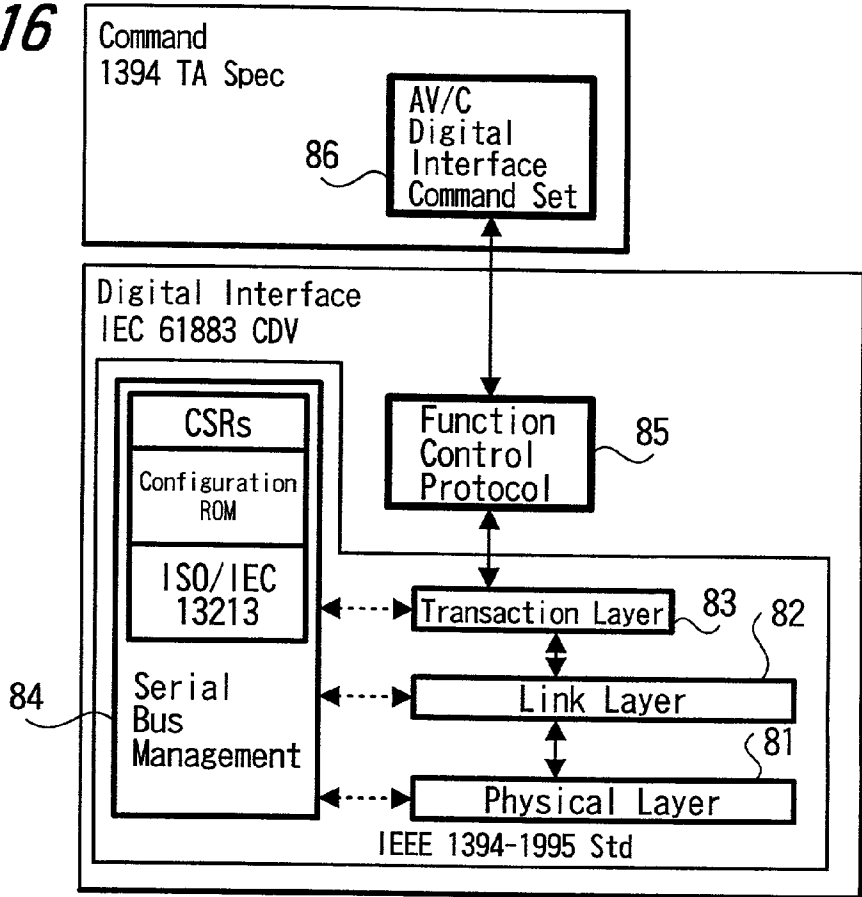

FIG. 17

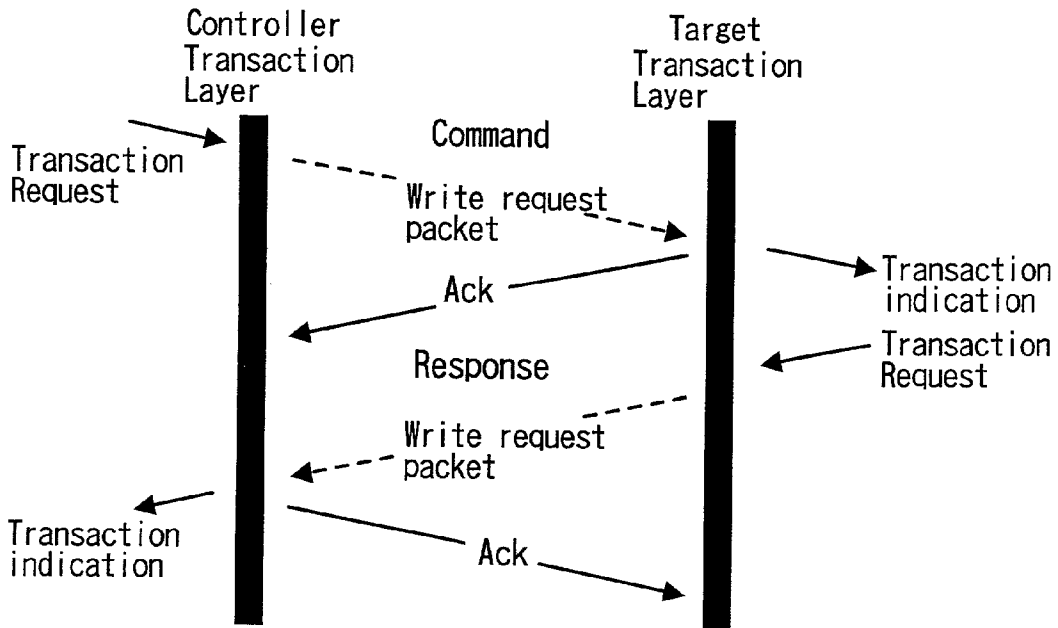

FIG. 18

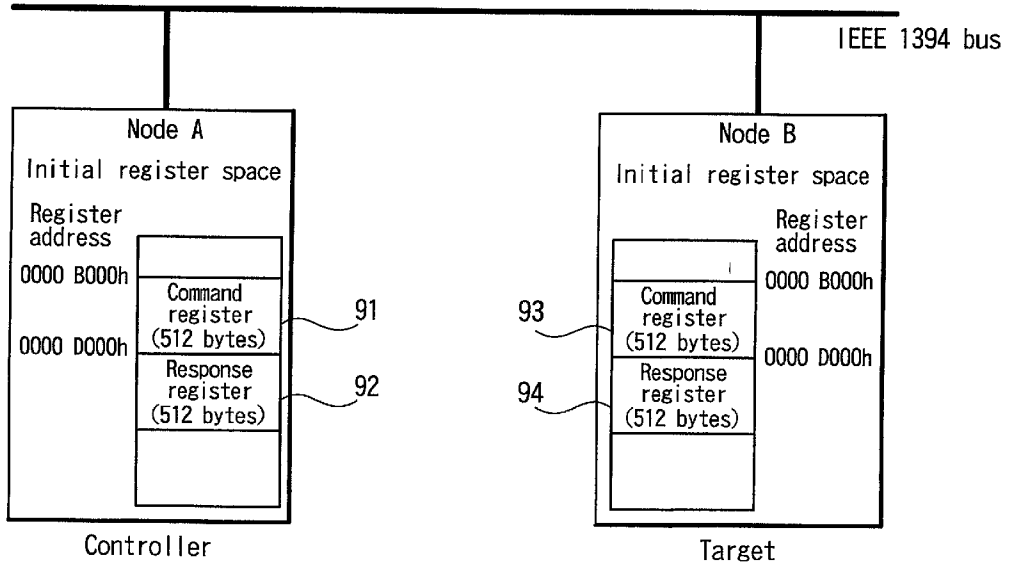
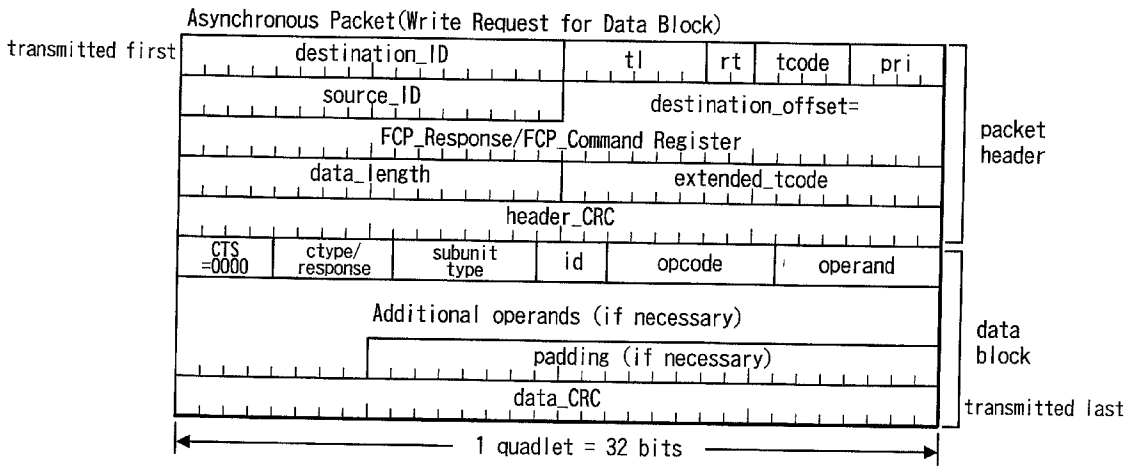

FIG. 19



ctype/response	
Command	0000 Control
	0001 Status
	0010 Specific Inquiry
	0011 Notify
	0100 General Inquiry
	0101
	? (reserved for future specification)
Response	0111
	1000 Not Implemented
	1001 Accepted
	1010 Rejected
	1011 In Transition
	1100 Implemented/Stable
	1101 Changed
1110 (reserved for future specification)	
1111 Interim	

FIG. 20A

subunit_type	
00000 ?	Video Monitor (reserved)
00011	Disc recorder/Player
00100	Tape recorder/Player
00101	Tuner
00111 ?	Video Camera (reserved)
11100	Vendor unique
11101	reserved
11110	Subunit type extended to next byte
11111	Unit

FIG. 20B

opcode: Operation Code	
00h	Vendor-Dependent
50h	Search Mode
51h	Time Code
52h	ATN
60h	Open MIC
61h	Read MIC
62h	Write MIC
C1h	Load Medium
C2h	Record
C3h	Play
C4h	Wind
?	?

FIG. 20C

FIG. 21A

AV/C	control	tape recorder /player	Case of Tape Recorder ID0	Play	Forward
CTS= 0000	ctype= 0000	subunit type= 00100	id= 000	opcode= C3h	operand= 75h

FIG. 21B

AV/C	accepted	tape recorder /player	Case of Tape Recorder ID0	Play	Forward
CTS= 0000	response =1001	subunit type= 00100	id= 000	opcode= C3h	operand= 75h

FIG. 22

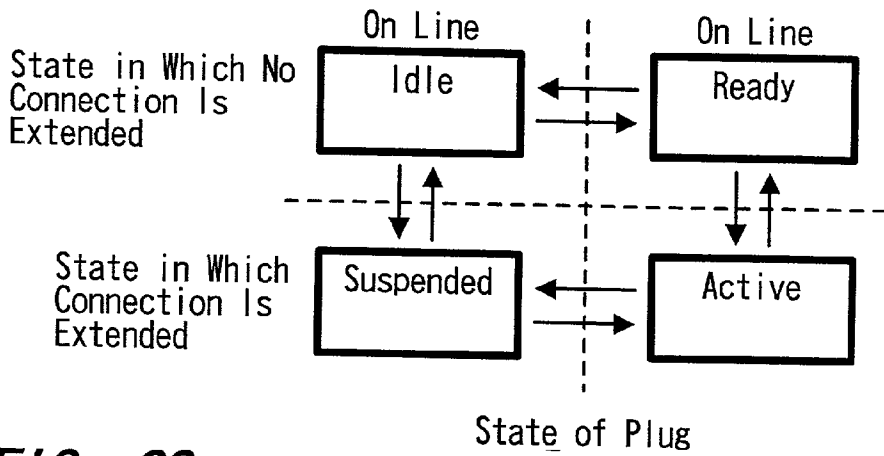

FIG. 23

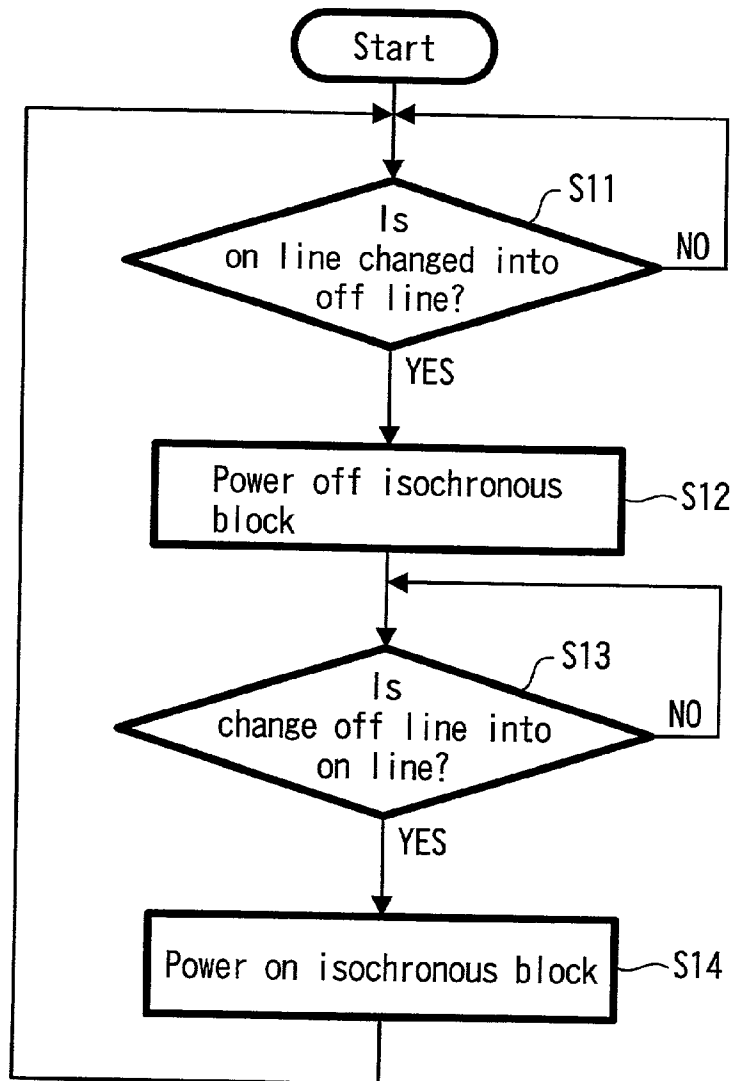
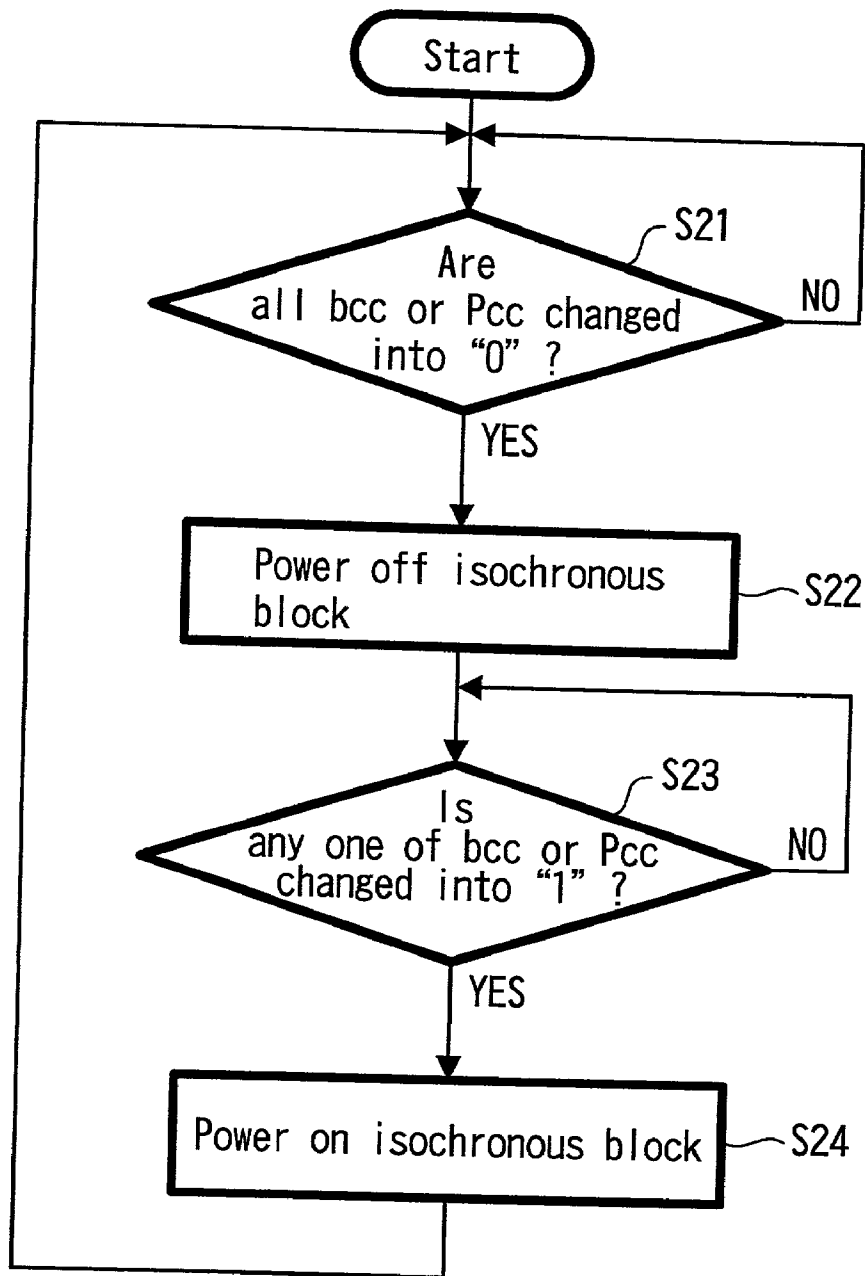

FIG. 24



CONTROL METHOD AND COMMUNICATION DEVICE

BACKGROUND OF THE INVENTION

[0001] 1. Field of the Invention

[0002] The present invention relates to a control method applied to data transmission between devices connected through a network of IEEE (The Institute of Electrical and Electronics Engineers) 1394 bus line or the like and a communication device to which the control method is applied.

[0003] 2. Description of the Prior Art

[0004] AV devices which can transmit information to each other through a network using an IEEE 1394 serial data bus are developed. When data transmission is performed through the bus, a synchronous communication mode used when audio data or the like is transmitted on real time and an asynchronous communication mode used when a static image, text data, a control command, or the like is reliably transmitted are prepared, bands dedicated to the respective modes are used in transmission. In the IEEE 1394 scheme, the synchronous communication mode is called an isochronous communication mode, and the asynchronous communication mode is called an asynchronous communication mode.

[0005] In communication in the isochronous communication mode, a device set as an IRM (Isochronous Resource Manager) in a network manages a channel and a band, and a device for executing communication isochronous communication mode performs the process of obtaining a channel and a band to the IRM. The channel mentioned here is a path for flowing isochronous data between a transmission side and a reception side, and the band mentioned here is in proportion to the size of a packet transmitted on one channel, and is a band amount isochronous communication which is in inverse proportion to a transmission rate.

[0006] By using the obtained channel and band, isochronous data is transmitted between the devices which connection is set. As settings of the connection, a point-to-point connection (called a PtP connection) for connecting an output plug of one device and an input plug of another device and a broadcast connection for performing transmission by using a channel for broadcast are known.

[0007] In communication in the asynchronous communication mode, an input plug and an output plug which are different from those in the isochronous communication mode are set, and communication is executed by a control process which is different from that in the isochronous communication mode.

[0008] A communication circuit included in a device connected to the IEEE 1394 bus line, as described above, has to communication modes having different communication forms. Since the communication circuit is designed such that communication in the isochronous communication mode and communication in the asynchronous communication mode can be executed, the communication circuit has a circuit configuration having a relatively large scale and a relatively high power consumption, disadvantageously.

[0009] Basically, in a device connected to the conventional IEEE 1394 bus line, only two states, i.e., a state in

which communication through the bus line can be performed and a state in which communication through the bus line cannot be performed at all because the power supply of the device is in an OFF state or a standby state can be selected. Therefore, when the power supply of the device is turned on to set the device in a state in which communication can be performed, a communication circuit connected to the bus line is always operates to consume power for the communication process.

[0010] The communication process in the device connected to the IEEE 1394 bus line has been described above. However, a similar problem is posed in communication devices for various communication methods which can perform communication in a synchronous communication mode and communication in an asynchronous communication mode simultaneously.

SUMMARY OF THE INVENTION

[0011] It is an object of the present invention to reduce a power consumption required for communication in a communication device connected to a network of this type.

[0012] In a control device according to the first aspect of the present invention, a power supply of a part for executing a communication process in a synchronous communication mode is controlled independently of a power supply of a part for executing a communication process in an asynchronous communication mode.

[0013] According to the first aspect of the present invention, the power supply of only the part for executing the communication process in the synchronous communication mode is independently controlled. For example, when synchronous communication need not be performed, the power supply of the part can be turned off.

[0014] In a control method according to the second aspect of the present invention, a power supply of a part for executing a communication process in an asynchronous communication mode is controlled independently of a power supply of a part for executing a communication process in a synchronous communication mode.

[0015] According to the second aspect of the present invention, the power supply of only the part for executing the communication process in the asynchronous communication mode is independently controlled. For example, when asynchronous communication need not be performed, the power supply of the part can be turned off.

[0016] A communication device according to the third aspect of the present invention includes a first communication process unit for performing a communication process in a synchronous communication mode, a second communication process unit for performing a communication process in an asynchronous communication mode, an input/output unit for performing a process between the first and second communication process units and a network, and a control unit which controls the synchronous communication and the asynchronous communication and can independently control only the power supply of the first communication process unit.

[0017] According to the third aspect of the present invention, only the power supply of the first communication process unit for executing the communication process in the

synchronous communication mode can be independently controlled by the control of the control unit. For example, the synchronous communication need not be performed, the power supply of only the first communication process unit can be turned off.

[0018] In a communication device according to the fourth aspect of the present invention includes a first communication process unit for performing a communication process in a synchronous communication mode, a second communication process unit for performing a communication process in an asynchronous communication mode, an input/output unit for performing a process between the first and second communication process units and a network, and a control unit which controls the synchronous communication and the asynchronous communication and can independently control only the power supply of the second communication process unit.

[0019] According to the fourth aspect of the present invention, only the power supply of the second communication process unit for executing the communication process in the asynchronous communication mode can be independently controlled by the control of the control unit. For example, the asynchronous communication need not be performed, the power supply of only the second communication process unit can be turned off.

BRIEF DESCRIPTION OF THE DRAWINGS

[0020] FIG. 1 is a block diagram showing an example of the configuration of an entire system according to an embodiment of the present invention;

[0021] FIG. 2 is a block diagram showing an example of the internal configuration of an IRD and a disk recording/reproducing device according to an embodiment of the present invention;

[0022] FIG. 3 is a block diagram showing an example of the configuration of a communication process unit according to an embodiment of the present invention;

[0023] FIG. 4 is a diagram for explaining an example of the cycle structure of data transmission on an IEEE 1394 bus;

[0024] FIG. 5 is a diagram for explaining an example of the structure of an address space of a CRS architecture;

[0025] FIG. 6 is a diagram for explaining examples of the position, name, and operation of a main CRS;

[0026] FIG. 7 is a diagram for explaining an example of a general ROM format;

[0027] FIG. 8 is a diagram for explaining examples of a bus info block, a root directory, and a unit directory;

[0028] FIG. 9 is a diagram for explaining an example of the configuration of a PCR;

[0029] FIGS. 10A to 10D are diagrams for explaining examples of the configurations of oMPR, an oPCR, and iPCR;

[0030] FIG. 11 is a diagram for explaining an example of the relationship among a plug, a plug control register, and a transmission channel;

[0031] FIG. 12 is a diagram for explaining an example of the data structure obtained by the hierarchical structure of a descriptor;

[0032] FIG. 13 is a diagram for explaining an example of the data format of the descriptor;

[0033] FIG. 14 is a diagram for explaining an example of a generation ID in FIG. 13;

[0034] FIG. 15 is a diagram for explaining an example of a list ID in FIG. 13;

[0035] FIG. 16 is a diagram for explaining an example of the stack model of an AV/C command;

[0036] FIG. 17 is a diagram for explaining the relationship between a command and a response of an FCP;

[0037] FIG. 18 is a diagram for explaining the relationship between the command and the response in FIG. 17 in detail;

[0038] FIG. 19 is a diagram for explaining an example of the data structure of an AV/C command;

[0039] FIGS. 20A to 20C are diagrams for explaining concrete examples of AV/C commands;

[0040] FIGS. 21A and 21B are diagram for explaining concrete examples of a command and a response of an AV/C command;

[0041] FIG. 22 is a diagram for explaining an example of the relationship between a state of a plug and a connection;

[0042] FIG. 23 is a flow chart showing an example of a power supply control process of an isochronous block; and

[0043] FIG. 24 is a flow chart showing another example of the power supply control process of an isochronous block.

DETAILED DESCRIPTION OF THE PREFERRED EMBODIMENTS

[0044] An embodiment of the present invention will be described below with reference to the accompanying drawings.

[0045] An example of the configuration of a network system to which the present invention is applied will be described below with reference to FIG. 1. In this network system, a plurality of devices are connected through a cable 26 constituting an IEEE 1394 serial data bus. In this case, as shown in FIG. 1, an IRD (Integrated Receiver Decoder) 10 having a terminal for connecting an IEEE 1394 bus and a disk recording/reproducing device 50 are connected to the cable 26. The cable 26 corresponds to the IEEE 1394 bus line.

[0046] The IRD 10 is a digital satellite broadcast receiver, and is designed to a receiving process of a signal input through a connected antenna 30 and also to perform a demodulation process or the like of a broadcast signal of the received channel. In this case, as the channel which can be received, in addition to a television broadcasting channel constituted by a video signal and an audio signal, a radio broadcasting channel constituted by an audio signal or a data broadcasting channel exists.

[0047] A television monitor 40 is connected to the IRD 10 through an analog cable. A program received by the IRD 10

can be viewed and heard with the monitor 40. The television monitor 40 may be connected to the cable 26 so that video data or the like may be transmitted to the television monitor 40 through the cable 26.

[0048] The disk recording/reproducing device 50 is a device which uses a photomagnetic disk called a mini disk (MD) or an optical disk as a recording medium to record and reproduce an audio signal or the like.

[0049] In FIG. 1, a network configuration is a most simple configuration in which only two devices are connected to the cable 26 serving as a bus line. However, another device is connected to the cable 26, so that a larger network configuration can also be obtained.

[0050] FIG. 2 is a diagram showing the details of a configuration which receives a broadcast signal of a digital satellite broadcast system and records the broadcast signal. A broadcast radio wave from a satellite (not shown) is received by the antenna 30 and transmitted to a tuner 11 serving as a program selection means arranged in the IRD 10 serving as a program receiving device. The IRD 10 is designed such that respective circuits operate on the basis of the control of a CPU 20. A reception signal S30 from a transponder selected by the tuner 11 is transmitted to a front-end unit 12.

[0051] The front-end unit 12 demodulates the reception signal S30 and performs an error correction process to reception data obtained as a result of the demodulation. Thereafter, the reception data is transmitted to a descramble circuit 13 as a reception data stream D31.

[0052] The descramble circuit 13, on the basis of cryptograph key information of a contract channel stored in an IC card (not shown) inserted into the body of the IRD 10, extracts multiplexing data D32 of the contract channel from the reception data stream D31 to transmit the multiplexing data D32 to a demultiplexer 14.

[0053] The demultiplexer 14 rearranges the multiplexing data D32 in units of channels, extracts only a channel designated by a user, transmits a video stream D33 constituted by the packet of a video portion to an MPEG video decoder 15, and transmits an overlap stream D34A constituted by the packet of an audio portion to an MPEG audio decoder 16.

[0054] The MPEG video decoder 15 decodes the video stream D33 to recover video data D35 obtained before compression coding, and transmits the recovered video data D35 to an NTSC encoder 17. The NTSC encoder 17 converts the video data D35 into a luminance signal and a color difference signal of the NTSC system, and transmits the luminance signal and the color difference signal to a digital analog conversion circuit 18 as NTSC data D36. The digital analog conversion circuit 18 converts the NTSC data D36 into an analog signal S37 and outputs the analog signal S37 to the monitor 40.

[0055] The MPEG audio decoder 16 decodes the overlap stream D34A to recover a PCM (Pulse Code Modulation) audio data D38 obtained before compression coding, and transmits the PCM audio data D38 to a digital-analog conversion circuit 19. The PCM audio data D38 is supplied to an interface 24, and can be transmitted to a bus line 26. In addition, the PCM audio data D38 can be directly

transmitted to a disk recording/reproducing device 50 through a cable 27 which is not a bus line.

[0056] The digital-analog conversion circuit 19 converts the PCM audio data D38 into an analog signal to generate an LCh audio signal S39A and an RCh audio signal S39B, outputs the LCh audio signal S39A and the RCh audio signal S39B as a speech through a loudspeaker (not shown) of the monitor 40, and transmits the LCh audio signal S39A and the RCh audio signal S39B to an analog-digital conversion circuit 58 of the disk recording/reproducing device 50.

[0057] When a music channel of contract channels is designed, the demultiplexer 14 transmits the audio stream D34A of the multiplexing data D32 to the MPEG audio decoder 16 and outputs speech-added information stream D34B serving as added information constituted by the packets of speech-added information to the CPU 20 through the IEEE 1394 interface 24.

[0058] The CPU 20 generates title data D40 from the packets of the speech-added information stream D34B expressed by characters, numbers, and the like on the basis of ID (IDentification) numbers added the packets.

[0059] At this time, the CPU 20 serving as a recording control means generates recording control data D41 serving as a control signal for controlling a recording operation such as a recording start operation or a recording stop operation on the basis of a recording instruction input by a user through an operation button (not shown) on an operation panel 23, and returns the recording control data D41 and the title data D40 as control data D42 to the IEEE 1394 interface 26.

[0060] The IEEE 1394 interface 26 transmit the control data D42 supplied from the CPU 20 from the IEEE 1394 cable 26 serving as a data transmission/reception means to a CPU 52 through an IEEE 1394 interface 51 of the disk recording/reproducing device 50 serving as a data recording/reproducing means, and transmits the PCM audio data D38 from the IEEE 1394 cable 26 to an ATRAC encoder 53 through the IEEE 1394 interface 51.

[0061] The ATRAC encoder 53 highly efficiently codes the PCM audio data D38 by the ATRAC system on the basis of the control of the CPU 52, and transmits the coded data to a recording/reproducing system 54 as PCM audio data D43.

[0062] The CPU 52 of the disk recording/reproducing device 50 is designed to control recording operations of a recording/reproducing system 54 and an optical pickup 55 on the basis of the recording control data D41 of the control data D42. Adding an error correction code and a predetermined modulation process to the PCM audio data D43 are performed by the recording/reproducing system 54. Thereafter, the PCM audio data D43 is recorded as recording data D44 in a designated region of a photomagnetic disk 56 serving as a recording medium through the optical pickup 55.

[0063] The CPU 52 of the disk recording/reproducing device 50 controls recording operations of the recording/reproducing system 54 and the optical pickup 55 on the basis of the recording control data D41, so that, of the title data D40, data expressed by half-size katakana and alphanumerical characters is recorded as kana alphanumerical code title

data D40A in a predetermined area of the photomagnetic disk 56, and records data expressed by full-size kanji and hiragana characters as kanji code title data D40B in a predetermined area.

[0064] In this manner, the IRD 10 controls the recording operation of the disk recording/reproducing device 50 by the CPU 20 to make it possible that the PCM audio data D38 can be recorded in a predetermined region of the photomagnetic disk 56 and to record the title data D40 corresponding to the PCM audio data D38 to be recorded in a predetermined area (TOC area) of the photomagnetic disk 56.

[0065] In reproduction, the disk recording/reproducing device 50 transmits reproduced data D45 reproduced by the optical pickup 55 to the recording/reproducing system 54. The recording/reproducing system 54 performs an error correction process and a predetermined demodulation process to the reproduced data D45 and transmits the reproduced data D45 to an ATRAC decoder 57 as reproduced data D46.

[0066] The ATRAC decoder 57 decodes the reproduced data D46 by the ATRAC system. The ATRAC decoder 57 externally outputs the decoded data D46 as digital reproduced data D47 through an optical digital cable 60 or converts the decoded data D46 into an analog LCh audio signal S48 and an analog RCh audio signal S49 to output the LCh audio signal S48 and the RCh audio signal S49 as speech from loudspeakers 61L and 61R connected to an amplification device 61.

[0067] The disk recording/reproducing device 50 reads title data D50 corresponding to the reproduced data D45, which is being reproduced, from the TOC 1 area or the TOC 4 area of the photomagnetic disk 56 by the optical pickup 55 and transmits the title data D50 to the recording/reproducing system 54. The recording/reproducing system 54 performs an error correction process and a predetermined demodulation process to the title data D50 and then transmits the processed title data D50 as title data D51 to the CPU 52.

[0068] The CPU 52 stores the title data D51 in a RAM 52A and transmits the title data D51 to a RAM 21 through the IEEE 1394 interface 51, the IEEE 1394 cable 26, the IEEE 1394 interface 24, and the CPU 20 to store the title data D51 in the RAM 21 serving as a storage means.

[0069] In this state, when instruction information for displaying image data corresponding to the title data D51 on the monitor 40 is input through an operation panel 46, the CPU 20 serving as a display control means reads title data D52 from the RAM 21 and transmits the title data D52 to the MPEG video decoder 15. The MPEG video decoder 15 performs a predetermined graphics process to the title data D52, and transmits the resultant image data to the monitor 40 through the NTSC encoder 17 and the digital-analog conversion circuit to display a GUI (Graphic User Interface) screen on the monitor 40 serving as the display means.

[0070] In reproduction from the disk, the reproduced audio data or the like may be transmitted from the IEEE 1394 interface 51 to another device through the cable 26.

[0071] The configuration for performing communication of the devices (in this case, the IRD 10 and the disk recording/reproducing device 50) constituted as described above and connected to the cable 26 serving as an IEEE

1394 bus line through the bus line of the devices will be described below with reference to FIG. 3.

[0072] In FIG. 3, a communication process block 100 is a processing block for performing communication with another device through the cable 26. This communication process block 100 corresponds to the IEEE 1394 interface 24 when the IRD 10 is used, and corresponds to the IEEE 1394 interface 51 when the disk recording/reproducing device 50 is used. In addition, a communication process in the communication process block 100 is executed by the control of a control unit 120. This control unit 120 corresponds to the CPU 20 when the IRD 10 is used, and corresponds to the CPU 52 when the disk recording/reproducing device 50 is used. In addition, a process for stream data transmitted by the communication process block 100 or a process for received stream data are executed by a signal processing unit 130. This signal processing unit 130 corresponds to a block for receiving broadcast data when the IRD 10 is used, and corresponds to a block for recording stream data on a disk and reproducing the stream data when the disk recording/reproducing device 50 is used.

[0073] In FIG. 3, a power circuit 140 for supplying a power to these blocks is shown. The supply state of the power supply from the power circuit 140 is controlled by the control unit 120. In particular, a power supply to an isochronous block 110 (to be described later) can be controlled independently of a power supply to another block. The details of the power supply process will be described later. In addition, an operation key pad 150 for setting the operations states of the devices is connected to the control unit 120. This operation key pad 150 is constituted by, e.g., the operation panel 23 in the IRD 10 shown in FIG. 2.

[0074] The configuration of the communication process block 100 for performing communication with an IEEE 1394 bus line will be described below. An input/output unit of this communication process block 100 directly connected to the cable 26 is called as a physical layer (PHY layer) 101. In this physical layer 101, an input process from the bus line and an output process to the bus line are performed.

[0075] To the physical layer 101, a reception unit 103 and a transmission unit 104 are connected through a physical layer interface unit 102. Here, for transmission in the IEEE 1394 bus line, communication in an isochronous communication mode which is a mode in which stream data is synchronously communicated and communication in an asynchronous communication mode which is a mode in which control data is asynchronously communicated can be performed. In the reception unit 103 and the transmission unit 104, the processes in both the communication modes can be performed. More specifically, in the reception unit 103, of data transmitted through the bus line, data the destination of which is set as the device is received, and data received in the isochronous communication mode is supplied to an isochronous data buffer 112 in the isochronous block 110. Data received in the asynchronous communication mode is supplied to an asynchronous data buffer 105. The transmission unit 104 performs a transmitting process to transmitted data supplied from the isochronous data buffer 112 in the isochronous block 110 in the isochronous communication mode, and performs a transmission process to transmitted data supplied from the asynchronous data buffer 105 in the asynchronous communication mode.

[0076] The isochronous block **110** is constituted by an isochronous signal processing unit **111** and an isochronous data buffer **112**. Isochronous data in units of received packets is supplied to the isochronous signal processing unit **111** through the buffer **112**, and continuous stream data is obtained on the basis of a time stamp added to the data. The obtained stream data is supplied to the signal processing unit **130**. When the stream data transmitted from the signal processing unit **130** is supplied, the stream data is divided by the isochronous signal processing unit **111** into isochronous data in units of packets, and time stamps are added to the data of the respective packets. The isochronous data divided in units of packets are transmitted to the transmission unit **104** through the buffer **112**. At a timing at which data is input to or output from the isochronous data buffer **112** is controlled by the isochronous signal processing unit **111**, the reception unit **103**, and the transmission unit **104**.

[0077] The isochronous signal processing unit **111** and the buffer **112** in the isochronous block **110** in this embodiment are designed such that the power supplies of the isochronous signal processing unit **111** and the buffer **112** are controlled independently of the other circuits in the communication process block **100**. More specifically, when power is supplied to the other circuits in the communication process block **100**, the power supply to the isochronous block **110** can be stopped.

[0078] An asynchronous signal processing unit **106** is connected to the asynchronous data buffer **105**, data (asynchronous packet) received in the asynchronous communication mode is determined by the asynchronous signal processing unit **106**, and is supplied to the control unit **120** if necessary. Data (asynchronous packet) transmitted from the asynchronous signal processing unit **106** is supplied to the transmission unit **104** through the buffer **105**. A register **107** for managing communication is connected to the asynchronous signal processing unit **106**. By the received data, data is written in the register **107**, and response to the data read from the register **107** is performed. The configuration of the register **107** will be explained in the description of a communication process configuration of the IEEE **1394** system. However, by using a partial storage area, a plug control register for imaginarily setting plugs in the respective communication modes is prepared. When isochronous communication is performed by the isochronous block **110**, reading and writing of the plug control register are performed in the asynchronous communication to extend connection and to perform communication. The value of the plug control register in the register **107** can be determined by the control unit **120**.

[0079] A communication state in an IEEE **1394** bus line and a process configuration required for the communication will be described below. FIG. **4** is a diagram showing the cycle structure of data transmission of devices connected by the IEEE **1394** bus line. In the IEEE **1394** bus line, data is divided into packets, and the packets are time-divisionally transmitted with reference a cycle having a length of $125\ \mu\text{S}$. This cycle is made by a cycle start signal supplied from a node (one of the devices connected to the bus) having a cycle master function. An isochronous packet secures a band (although the band is a time unit) required for transmission from the starts of all the cycles. For this reason, in isochronous transmission, transmission of data within a predetermined period of time is assured. However, a transmission

error is generated, a protecting device is not arranged, data is lost. In a period of time which is not used for isochronous transmission of each cycle, a node which secures a bus as a result of arbitration transmits an asynchronous packet in the asynchronous transmission. However, in the asynchronous transmission asynchronous packet, by using acknowledge and retry, reliable transmission is assured, but a transmission timing is not constant.

[0080] In order to cause a predetermined node to perform isochronous transmission, the node must correspond to an isochronous function. At least one of nodes corresponding to the isochronous function must have a cycle master function. In addition, at least one of nodes connected to the IEEE **1394** serial bus must have the function of isochronous resource manager.

[0081] The IEEE **1394** conforms to a CSR (Control & Status Register) architecture having 64-bit address space regulated by ISO/IEC **13213**. FIG. **5** is a diagram for explaining the structure of the address space of the CSR architecture. This data is registered in the register **107** shown in FIG. **3** and set. The upper 16 bits correspond to a node ID representing a node on each IEEE **1394** bus line, and the remaining 48 bits are used to designate an address space given to each node. The upper 16 bits are divided into 10 bits of a bus ID and 6 bits of a physical ID (which strictly means a node ID). Since a value at which all the bits are 1 each is used for a special purpose, **1023** buses and **63** nodes can be designated.

[0082] A space regulated by upper 20 bits of an address space regulated by lower 48 bits is divided into an initial register space (Initial Register Space) used in a register inherent in a 2048-byte CSR, a register inherent in IEEE **1394**, or the like, a private space (Private Space), an initial memory space (Initial Memory Space) and the like. A space regulated by lower 28 bits, when a space regulated by the upper 20 bits is an initial register space, is used as a configuration ROM (Configuration ROM), an initial unit space (Initial Unit Space) used for a purpose inherent in a node, a plug control register (Plug Control Register (PCRS)), or the like.

[0083] FIG. **6** is a diagram for explaining offset addresses, names, and operations of a main CSR. An offset in FIG. **6** represents an offset address from number FFFF000000h (a number having h at the last represents a number in hexadecimal notation) at which an initial register space is started. A bandwidth available register (Bandwidth Available Register) having an offset 220h represents a band which can be allocated to isochronous communication, and only the value of a node operated as an isochronous resource manager (IRM) is made effective. More specifically, although the CSR in FIG. **5** is included in each node, a bandwidth available register of only the isochronous resource manager is made effective. In other words, the bandwidth available register is substantially included in only the isochronous resource manager. The maximum value is stored in the bandwidth available register when no band is allocated to the isochronous communication, and the value decreases each time a band is allocated to the isochronous communication.

[0084] A channels available register (Channels Available Register) of offsets 224h to 228h has bits corresponding channel numbers 0 to 63. A bit of 0 represents that the

channel has been allocated. only the channels available register of a node operating as an isochronous resource manager is effective.

[0085] Returning to FIG. 5, at addresses 200h to 400h in the initial register space, configuration ROMs based on a general ROM format are arranged. FIG. 7 is a diagram for explaining the general ROM format. A node serving as a unit of access on the IEEE 1394 can have a plurality of units which independently operate while commonly using an address space. Unit directories can indicate the versions and positions of pieces of software corresponding to the units. Although the positions of a bus info block and a root directory are fixed, the positions of other blocks are designated by offset addresses.

[0086] FIG. 8 is a diagram showing the details of a bus info block, a root directory, and a unit directory. In Company ID in the bus info block, an ID number representing a manufacturer of a device is stored. In Chip ID, a unique ID in the world which is not equal to the IDs of other devices. In addition, according to the standards of IEC 61833, in the unit spec ID of the unit directory of a device which satisfies the IEC 61883 standards, 00h, A0h, and 2Dh are written in the first octet, the second octet, and the third octet, respectively. Furthermore, 01h is written in the first octet of a unit switch version (unit sw version), and 1 is written in the LSB (least Significant Bit) of the third octet.

[0087] Since input/output operations of a device are controlled through an interface, a node has a PCR (Plug Control Register) regulated by the IEC 61883 standards at addresses 900h to 9FFh in the initial unit space in FIG. 5. In this case, in order to form a signal path logically similar to an analog interface, the concept of a plug is imaginarily constituted by a register to be embodied.

[0088] FIG. 9 is a diagram for explaining the configuration of the PCR. The PCR has an oPCR (output Plug Control Register) representing an output plug and an iPCR (input Plug Control Register) representing an input plug. The PCR also has a register oMPR (output Master Plug Register) and an IMPR (input Master Plug Register) representing an output plug or an input plug inherent in each device. Each device does not have a plurality of oMPRs and a plurality of iPCRs, but each device can have a plurality of oPCR and a plurality of iPCR corresponding to each plug depending on the capability of the device. The PCR shown in FIG. 9 has 31 oPCRs and 31 iPCRs. A flow of isochronous data is controlled by operating registers corresponding to these plugs.

[0089] FIGS. 10A to 10D are diagrams showing the configurations of an oMPR, an oPCR, an iMPR, and an iPCR. FIG. 10A shows the configuration of the oMPR, and FIG. 10B shows the configuration of the oPCR. FIG. 10C shows the configuration of the iMPR, and FIG. 10D shows the configuration of the iPCR. In 2-bit data rate capability on the MSB side of the oMPR and the IMPR, a code representing the maximum transmission rate of isochronous data which can be transmitted and received by the device. The broadcast channel base of the oMPR regulates the number of a channel used in broadcast outputting.

[0090] In 5-bit number of output plugs on the LSB side of the oMPR, the number of output plugs included in the device, i.e., the value representing the number of oPCRs is

stored. In 5-bit number of input plugs on the LSB side of the iMPR, the number of input plugs included in the device, i.e., the value representing the number of iPCRs. A non-persistent extension field and a persistent extension field are regions defined for expansion in the future.

[0091] The on-lines of the MSBs of the oPCR and iPCR represent using states of the plugs. More specifically, a value of 1 represents an on-line plug, and a value of 0 represents an off-line plug. The on-line plug represents a state in which transmission can be performed by using the plug. The off-line plug represents a state in which transmission cannot be performed by using the plug. The values of the broadcast connection counter (bcc) of the oPCR and the iPCR are 1 when a broadcast connection is extended. The values are 0 when a broadcast connection is not extended.

[0092] Values of a point-to-point connection counter (pcc) having a 6-bit width of the oPCR and the iPCR represent states of a point-to-point connection included in the plug. The value of the point-to-point connection counter is any one of values of 1 to 63 when a PtoP connection is extended. The value is 0 when the PtoP connection is not extended. Therefore, a state in which all the 7 bits of the broadcast connection counter and the point-to-point connection counter are 0 data represents a state in which a connection is not extended to the corresponding plug, and a state in which at least one bit of the 7 bits is 1 data represents a state in which a connection is extended to the plug.

[0093] Values of channel numbers each having a 6-bit width of the oPCR and the iPCR represent the numbers of isochronous channels to which the plug is connected. The value of a data rate having a 2-bit width of the oPCR represents an actual transmission rate of a packet of isochronous data output from the plug. Three types of transmission rates, e.g., 100 Mbps (S100 mode), 200 Mbps (S200 mode), and 400 Mbps (S400 mode) are prepared. The value of the data rate represents a transmission rate which is selected from the three types of transmission rates and at which data is transmitted by the connection obtained at that time. A code stored in an overhead ID having a 4-bit width of the oPCR is a value obtained in consideration of propagation delay occurring when stream data is transmitted by isochronous communication. The value of a payload having a 10-bit width of the oPCR represents the size of stream data transmitted by the plug in a quadlet unit.

[0094] FIG. 11 is diagram showing the relationship between a plug, a plug control register, and an isochronous channel. The AV devices 71 to 73 are connected to each other through an IEEE 1394 serial bus. Of oPCR [0] to oPCR [2] in which transmission rates and the numbers of oPCR are regulated by the oMPR of the AV device 73, isochronous data having a channel designated by oPCR [1] is transmitted to a channel #1 of the IEEE 1394 serial bus. Of an iPCR [0] and an iPCR [1] in which transmission rates and the number of iPCRs are regulated by the iMPR of the AV device 71, the input channel #1 is set by the iPCR [0], and the AV device 71 reads the isochronous data transmitted to the channel #1 of the IEEE 1394 serial bus. Similarly, the AV device 72 transmits isochronous data to a channel #2 designated by the oPCR, and the AV device 71 reads the isochronous data from the channel #2 designated by the iPCR [1].

[0095] In this manner, data transmission is performed between devices connected to each other through an IEEE

1394 serial bus. However, in the system of this embodiment, by using an AV/C command set regulated as a command for controlling the devices connected to each other through the IEEE **1394** serial bus, control of the devices and decision of the states of the devices can be performed. The AV/C command set will be described below.

[**0096**] When various pieces of information are recorded by the system according to this embodiment, the data structure of Subunit Identifier Descriptor to be used will be described below with reference to FIGS. **12** to **15**. **FIG. 12** shows the data structure of Subunit Identifier Descriptor. As shown in **FIG. 12**, the data structure is constituted by the list of a hierarchical structure of Subunit Identifier Descriptor. The list indicates a receivable channel when a tuner is used, and, when a disk is used, the list indicates the names of songs recorded on the disk. The list of the uppermost layer of the hierarchical structure is called a root list. For example, list 0 is a root corresponding to the lower list of the list of the uppermost layer. Lists 2 to (n-1) are similarly root lists. The number of root lists is equal to the number of objects. Here, the object indicates each channel or the like in digital broadcast when an AV device is a tuner. All the lists of one layer share common information.

[**0097**] **FIG. 13** shows the format of the general subunit identifier descriptor. In Subunit Identifier Descriptor, subsidiary information related to a function is described in contents. The value of descriptor length field itself is not included. Generation ID represents the version of an AV/C command set. The value of the generation ID is "00h" (h represents hexadecimal notation) at the present as shown in **FIG. 14**. Here, "00h" means that data structures and command sets are specified in version 3.0 of the AV/C general specification. As shown in **FIG. 14**, all the values except for "00h" are preserved and secured for specifications in the future.

[**0098**] Size of list ID represents the number of bytes of a list ID. The size of object ID represents the number of an object ID. Size of object position represents a position (the number of bytes) in a list used in referring is performed in control. Number of root object lists represents the number of root object lists. Root object list id represents an ID for identifying the root object list of the uppermost layer of the independent layers.

[**0099**] Subunit dependent length represents the number of bytes of the subsequent subunit dependent information field. The subunit dependent information is a field representing information inherent in a function. Manufacturer dependent length represents the number of bytes of the subsequent manufacturer dependent information field. The manufacturer dependent information is a field representing specification information of a vender (maker). When no manufacturer dependent information is not included in a descriptor, the field does not exist.

[**0100**] **FIG. 15** shows an allocation range of the list ID shown in **FIG. 13**. As shown in **FIG. 15**, "0000h" to 0FFFh" and "4000h to FFFFh" are secured and preserved as an allocation range for specifications in the future. "1000h to 3FFFh" and "10000h to max list ID value" are prepared to identify subsidiary information of a function type.

[**0101**] An AV/C command set used in this embodiment will be described below with reference to FIGS. **16** to **21**.

FIG. 16 shows a stack model of the AV/C command set. As shown in **FIG. 16**, a physical layer **81**, a link layer **82**, a transaction layer **83**, and a serial bus management **84** conform to the IEEE **1394**. An FCP (Function Control Protocol) **85** conforms to the IEC **61883**. An AV/C command set **86** conforms to AV/C Digital Interface Command Set General Specification.

[**0102**] **FIG. 17** is a diagram for explaining a command and a response of the FCP (Function Control Protocol) **85** in **FIG. 16**. FCP is a protocol for performing the control of an AV device on an IEEE **1394** bus. As shown in **FIG. 17**, a controller controls a target, and the target is controlled by the controller. Transmission of the command or the response of the FCP is performed between nodes by using light transaction of IEEE **1394** asynchronous communication. The target which receives data returns an acknowledge to the controller for confirming reception.

[**0103**] **FIG. 18** is a diagram for more exactly explaining the relationship between the command and the response of the FCP shown in **FIG. 17**. A node A and a node B are connected to each other through an IEEE **1394** bus. The node A is a controller, and the node B is a target. For each of the nodes A and B, a 512-byte command register and a 512-byte response register are prepared. As shown in **FIG. 18**, the controller writes a command message in a command register **93** of the target to transmit an instruction. In contrast to this, the target writes a response message in a response register **92** of the controller to transmit a response. For the two messages, control information is exchanged. The type of a command set transmitted by the FCP is described in a CTS in a data field in **FIG. 19** (to be described later).

[**0104**] **FIG. 19** shows the data structure of a packet transmitted in an asynchronous transfer mode of an AV/C command. The AV/C command set is a command set for controlling an AV device, and has a CTS (ID of the command set)="0000". An AV/C command frame and a response frame are exchanged between nodes using the FCP. In order to reduce a load on the bus and the AV device, a response to the command must be performed within 100 ms. As shown in **FIG. 19**, the data of an asynchronous packet is constituted by 32 bits (=1 quadlet) in the horizontal direction. The upper half in **FIG. 19** shows the header portion of the packet, and the lower half shows a data block. Destination ID represents a destination.

[**0105**] CTS represents the ID of a command set, and satisfies CTS="0000" in the AV/C command set. The field of ctype/response represents a function classification when the packet is a command, and represents a process result of the command when the packet is a response. Commands are roughly classified into four types, i.e., (1) a command (CONTROL) for controlling a function from the outside, (2) a command (STATUS) for inquiring about a state from the outside, (3) a command (GENERAL INQUIRY (the presence/absence of support of opcode) and SPECIFIC INQUIRY (the presence/absence of support of opcode and operands)), and (4) a command (NOTIFY) for requiring that a change in state is notified to the outside.

[**0106**] A response is returned depending on the type of a command. As responses to the CONTROL command, NOT IMPLEMENTED (not implemented), ACCEPTED (accepted), REJECTED (rejection), and INTERIM (interim) are known. As responses to the STATUS command, NOT

IMPLEMENTED, REJECTED, IN TRANSITION (transition is being performed), and STABLE (stability) are known. As responses to GENERAL INQUIRY command and SPECIFIC INQUIRY command, IMPLEMENTED (implemented) and NOT IMPLEMENTED are known. As responses to NOTIFY command, NOT IMPLEMENTED, REJECTED, INTERIM, and CHANGED (changed) are known.

[0107] Subunit type is set to specify a function in the device. For example, a tape recorder/player, a tuner, or the like is allocated to the subunit type. In order to perform a discrimination when a plurality of subunits of the same type exist, addressing is performed by subunit id as a discrimination number. Opcode represents a command, and operand represents a parameter of the command. Additional operands are fields indicates a field added as needed. Padding indicates a field added as needed. Data CRC (Cyclic Redundancy Check) is used for error check in data transmission.

[0108] FIGS. 20A to 20C shows concrete examples of the AV/C command. FIG. 20A shows a concrete example of ctype/response. The upper half in FIG. 20A represents a command, and the lower half in FIG. 20A represents a response. CONTROL is allocated to "0000", STATUS is allocated to "0001", SPECIFIC INQUIRY is allocated to "0010", NOTIFY is allocated to "0011", GENERAL INQUIRY is allocated to "0100". "0101 to 0111" are preserved and secured for specifications in the future. NOT IMPLEMENTED is allocated to "1000", ACCEPTED is allocated to "1001", REJECTED is allocated to "1010", IN TRANSITION is allocated to "1011", IMPLEMENTED/STABLE is allocated to "1100", CHANGED is allocated to "1101", and INTERIM is allocated to "1111". "1110" is preserved and secured for specifications in the future.

[0109] FIG. 20B shows a concrete example of subunit type. Video Monitor is allocated to "00000", Disk recorder/Player is allocated to "00011", Tape recorder/Player is allocated to "00100", Tuner is allocated to "00101", Video Camera is allocated to "00111", Vender unique is allocated to "11100", Subunit type extended to next byte is allocated to "11110". Although a unit is allocated to "11111". This is used when the device itself is transmitted. For example, an ON/OFF operation of a power supply is known.

[0110] FIG. 20C shows a concrete example of opcode. Tables of opcode exist for subunit types, respectively. Here, FIG. 20C a shows opcode obtained when the subunit type is Tape recorder/Player. Operand is defined every opcode. In this case, VENDER-DEPENDENT is allocated to "00h", SEARCH MODE is allocated to "50h", TIMECODE is allocated to "51h", ATN is allocated to "52h", OPEN MIC is allocated to "60h", READ MIC is allocated to "61h", WHITE MIC is allocated to "62h", LOAD MEDIUM is allocated to "C1h", RECORD is allocated to "C2h", PLAY is allocated to "C3h", and WIND is allocated to "C4h".

[0111] FIGS. 21A and 21B show concrete examples of an AV/C command and a response. For example, when a reproducing device serving as a target (consumer) is instructed to be reproduced, the controller sends a command shown in FIG. 21A to the target. Since this command uses an AV/C command set, CTS="0000" is satisfied. Since a command (CONTROL) for controlling the device from the outside is used for ctype, ctype="0000" is satisfied (see FIG. 20A). Since the subunit type is Tape recorder/Player, subunit

type="00100" is satisfied (see FIG. 20B). id represents that ID is 0, and id=000 is satisfied. Opcode is "C3h" meaning reproduction (FIG. 20C). Operand is "75h" meaning FORWARD. When data is reproduced, the target returns a response as shown in FIG. 21B to the controller. In this case, ACCEPTED meaning acceptance is set in the response, response="1001" is satisfied (see FIG. 20A). Since FIG. 21B is the same as FIG. 21A except for the response, a description thereof will be omitted.

[0112] A control process for the states of devices in this embodiment when communication is performed between the devices connected to each other through the IEEE 1394 bus line described above will be described below. As has been described with reference to FIGS. 9 and 10, in this embodiment, a plug regulated by the standards of IEC 61883 and called a PCR is set in a register. When isochronous communication is performed by the plug, a connection to another device is set. In this case, using states of plugs are represented by on-line data for the output plug oPCR shown in FIG. 10B and the input plug iPCR shown in FIG. 10D. An on-line state or an off-line state is determined on the basis of the on-line data, so that the control unit of the device controls the power supplies of the communication process block and the peripheral circuit thereof.

[0113] A case in which the plug of the device is in an on-line state and a case in which the plug of the device is in an off-line state will be described below with reference to FIG. 22. When a connection is extended to the corresponding plug or no connection is extended to the corresponding plug, the on-line state and the off-line state exist. More specifically, when a connection is extended to the corresponding plug to set an on-line state, an active state in which an isochronous packet can be output or input is set. When a connection is extended to the corresponding plug to set an off-line state, a suspended state in which the device is on standby to output or input an isochronous packet is set. In addition, when no connection is extended to the corresponding plug to set an on-line state, a ready state in which the isochronous packet cannot be output or input is set. When no connection is extended to set an off-line state, an idle state in which communication cannot be performed is set. When data is written in a register constituting the plug, a change between the on-line state and the off-line state and a change between a state in which a connection is extended and a state in which no connection is extended are performed.

[0114] As is apparent from FIG. 22, an isochronous packet is actually input or output in only an on-line state. In this embodiment, in consideration of this point, in the off-line state, a power is not supplied to a circuit for performing isochronous communication. More specifically, the settings of the plugs of the register 107 in the communication processing block 100 shown in FIG. 3 are determined by the control unit 120. When it is determined that all the plugs for the isochronous communication are in off-line states, a power supply from the power supply circuit 140 to the isochronous block 110 is stopped, so that a power-off state is set. A power is always supplied to the other circuits in the communication processing block 100 while the device in which the communication processing block 100 is built operates to set a state in which asynchronous communication can be performed.

[0115] The on-line and off-line states are designed to be set by the power supply mode of the device in which the

communication processing block **100** is built. For example, as shown in the next [Table 1], the power supply of the device is set in an ON state by operating the power supply key in the operation key pad **150**, the states of all the oPCR and iPCR in the device are set in on-line states. When the device is set in a standby state by operating the power supply key in the operation key pad **150** prepared for the device, the states of all the oPCR and iPCR in the device are set in off-line states. In the on-line state, an ON state for supplying a power to the isochronous communication process unit is set. In the off-line state, an OFF state for stopping power supply to the isochronous communication process unit is set.

Power Supply Mode of Device	Power Supply of Isochronous Communication Process Unit	State of PCR
Standby	OFF	Off-line
ON	ON	On-line

[0116] In addition to the case in which the power supply key pad prepared for the device is directly operated to control the power supply, a case in which settings of a power-on state and a standby state are controlled from another device by transmission of the AV/C command.

[0117] The flow chart in FIG. 23 shows an example of the process in which the settings of the plugs of register **107** are determined by the control unit **120** to perform power supply control of the isochronous block. This process will be described below. It is assumed, as an initial state, that the power supply of the isochronous block is set in an ON state. The control unit **120** checks whether the states of the plugs in the register **107** are changed from the on-line states to the off-line states or not (step S11). If the states are not changed, the control unit **120** is on standby in this state. If the change from the on-line states to the off-line states is detected, power supply from the power supply circuit **140** to the isochronous block **110** is stopped to set a power-off state (step S12).

[0118] After the power-off state is set, it is checked whether the states of the plugs in the register **107** are changed from the off-line states to the on-line states or not (step S13). If the states are not changed, the control unit **120** is on standby. If the change from the off-line states to the on-line states is detected, power supply from the power supply circuit **140** to the isochronous block **110** is started to set a power-on state (step S14). Thereafter, the flow returns to the decision in step S11.

[0119] In this manner, on the basis of the settings of the on-line states and the off-line states of the plugs for isochronous communication, a power supply of a part for performing signal processing for the isochronous communication is controlled. For this reason, in a period of time in which isochronous communication need not be performed, the power supply of the part for performing a process for isochronous communication can be turned off, so that a power consumption of the communication circuit can be reduced. In this case, since power is always supplied to the part for performing signal processing for the isochronous communication to set the portion in an operation state, the device can always asynchronously communicate with another device. On the network configuration, the corre-

sponding device (node) keeps connected to the bus line, bus reset or the like does not occur, re-adding of a node ID caused by the bus reset is not performed, and a controller on the network need not frequently perform the bus reset. For this reason, a control process of the network is simplified.

[0120] When the power supply of a signal processing unit for isochronous communication is turned off, the device can asynchronously communicate with another device. For this reason, an instruction for turning on the power supply of a signal processing unit for isochronous communication of the device is transmitted such that the AV/C command or the like from another device by the asynchronous communication, and the corresponding process can also be performed. Even though the power supply of the isochronous block is in an OFF state, a measure to transmit stream data from another device can be made.

[0121] In the process shown in FIG. 23, on the basis of detection of the on-line states and the off-line states of the plugs, the power supply of the isochronous block is controlled independently of another block. However, on the basis of detection of other states, the power supply of the isochronous block may be performed independently of another block. The flow chart in FIG. 24 shows another example. In this example, in the output plug oPCR shown in FIG. 10B and the input plug iPCR shown in FIG. 10D, the setting states of the connections are decided on the basis of a value of a broadcast connection counter (bcc) and the value of a point-to-point connection counter (pcc). When it is decided by the decision that any connection does not set, the power supply is turned off.

[0122] More specifically, as shown in FIG. 24, if the power supply of the isochronous block is in an ON state as an initial state, the control unit **120** decides the states of the plugs in the register **107** to decide whether the values of the bcc and the pcc of all the plugs are 0 data or not (step S21). When the values are not changed, the control unit **120** is on standby. When it is detected that the values of the bcc and the pcc of all the plugs are 0 data, power supply from the power supply circuit **140** to the isochronous block **110** is stopped to set a power-off state (step S22).

[0123] After the power-off state is set, the states of the plugs in the register **107** are decided, and it is decided whether any one of the bits of the value of the bcc or the pcc of any one of the plugs is 1 data or not (step S23). When the value is not changed, the control unit **120** is on standby. When it is detected that any one of the bits of the value of the bcc or the pcc of any one of the plugs is 1 data, power supply from the power supply circuit **140** to the isochronous block **110** is started to set a power-off state (step S24). Thereafter, the flow returns to the decision in step S21.

[0124] When the process is performed as described above, as in the case of the flow chart in FIG. 23, the presence/absence of isochronous communication is reliably decided to control the ON or OFF state of the power supply of the isochronous block. When the isochronous communication need not be performed, the power supply of the block for performing the communication process is turned off, so that a power consumption of the communication circuit can be reduced.

[0125] In the flow charts in FIGS. 23 and 24, the state of the plugs for isochronous communication are decided. When

the isochronous communication need not be performed, the power supply of the block for the isochronous communication process is turned off. However, the power supply of the block for the isochronous communication process can be independently controlled depending on the operation state of the power supply key of the device. More specifically, when a power-on state is set as a power-on state of the device (i.e., the device is set in an operation state), both of the power supply of the block for an isochronous communication process and the power supply of the block for an asynchronous communication process are turned on to set in a standby state (i.e., only the control unit of the device is set in an operation state), the power supply of the block for the isochronous communication process may be turned off, and only the power supply of the block for the asynchronous communication process may be kept in an ON state. In this case, a power-off state can be set independently of a standby state, so as to a mode in which both the power supplies, i.e., the power supply of the block for the isochronous communication process and the power supply of the block for the asynchronous communication process can be turned off may be able to be set.

[0126] In the embodiment described above, power supply control is performed in only the block for directly performing a communication process. However, power supply control for a circuit block depending on the format of stream data for performing a transmission process or a reception process in the block may also be performed while being linked with the power supply control of the block for performing the isochronous block.

[0127] For example, when the power supply of the isochronous communication block in the disk recording/reproducing device 50 is turned off, the power supplies of the block for performing a recording process of data obtained in this block in the ATRAC system and the block for performing a reproducing process the data in the ATRAC system to transmit the data to the isochronous communication block may be turned off.

[0128] In addition, for example, when the power supply of the isochronous communication block in the IRD 10 is in an OFF state, the block for performing a process in which video data of the MPEG system is received by the device in the block is in a power-off state, so that a receiving process of the video data or the like which is stream data output from the isochronous communication block may not be performed. In this manner, a power consumption of the device can be further reduced.

[0129] In the embodiment described above, on the basis of the state of a register in the communication process block, the power supply of the isochronous communication block is controlled. However, the power supply of the isochronous communication block may be automatically controlled while being linked with any state of the device. For example, in a device using a recording medium such as the disk recording/reproducing device 50, the power supply of the isochronous communication block may be controlled while being linked with loading a recording medium (disk) on the device. More specifically, when no recording medium is loaded on the device, it is decided that stream data need not be input or output by the device, and the control unit sets the power supply of the isochronous communication block in an off state. When the recording medium is loaded, data can be

recorded or reproduced by the device. For this reason, the control unit may set the power supply of the isochronous communication block in an ON state. In this manner, on the basis of the state of the device, the power supply of the isochronous communication block can be appropriately controlled. The disk recording/reproducing device 50 of this embodiment is a recording device for audio data. However, when a recording/reproducing device for recording video data or the like on a medium (disk, tape, memory card, or the like) and reproducing the video data is used, similarly, the power supply of the isochronous communication process unit may be controlled while being linked with the presence/absence of a loaded medium.

[0130] In the embodiment described above, as a device in which the communication processing block 100 shown in FIG. 3 is built, the IRD 10 and the disk recording/reproducing device 50 are described. However, the present invention can also be applied to a case in which a similar communication process block is built in another device and connected to a bus line to perform synchronous communication and asynchronous communication.

[0131] In the embodiment described above, power supply to the block for performing an isochronous communication process is controlled independently of a block for performing another communication process. However, the power supply of the block (i.e., a block for asynchronous communication) for performing the asynchronous communication process may be controlled independently of the block for performing the other communication process. More specifically, for example, the power supply of the asynchronous signal processing unit 106 and the power supply of the asynchronous data buffer 105 in the communication processing block 100 shown in FIG. 3 are designed to be controlled independently of the other circuits in the communication processing block 100. When the control unit 120 decides that only asynchronous communication need not be performed, power supply to the asynchronous signal processing unit 106 and the asynchronous data buffer 105 are stopped.

[0132] In the state in which only the asynchronous communication need not be performed, a monitoring video camera is used as a device having a communication process block 100 built therein, and photographing is continuously executed by the monitoring video camera in a constant state. A process in which video data obtained by the photographing is always continuously transmitted to a recording device or a monitor is performed in an isochronous communication mode. It is assumed that a command for performing operation control of the video camera need not be transmitted by the asynchronous communication.

[0133] In such a case, when the power supply of the block for processing asynchronous communication is turned off, a communication process can be performed with a small power consumption, and monitoring can be continuously performed in a constant state. Even though a device except for the monitoring camera is used, when transmission of serial stream data must be continuously transmitted in a constant state, similarly, only the block for processing the asynchronous communication may be independently controlled.

[0134] In the embodiment described above, a network constituted by an IEEE 1394 bus has been described. How-

ever, the present invention can also be applied to a case in which the same data transmission is performed between devices connected through another network configuration (e.g., USB). As a transmission path between the devices, a wireless transmission path may also be used in addition to the bus line described above. As the wireless transmission path, when a network is constituted between a plurality of devices by wireless communication of the standards called, e.g., Bluetooth, the power supply of at least one of a block for performing a synchronous communication process and a block for performing an asynchronous communication process can be independently controlled by the devices in the network.

[0135] According to a control method described in the first aspect of the present invention, a power supply of only a part for executing a communication process in a synchronous communication mode is independently controlled. For example, when synchronous communication need not be performed, the power supply of the portion can be turned off. Therefore, power may be supplied to the part for executing the communication process in the synchronous mode only when synchronous communication must be performed, so that power required for the communication process can be reduced.

[0136] According to a control method described in the second aspect of the present invention, in the invention described in the first aspect, the power supply of the part for executing the communication process in the synchronous communication mode is turned off in a period in which the communication in the synchronous communication mode is not executed, and a state in which only a power supply of a part for executing a communication process in an asynchronous communication mode is turned on is set. For this reason, the power supply of only the communication process unit in the asynchronous communication mode may be turned on in a period in which the communication in the synchronous communication mode is not performed, and power required for the communication process can be reduced.

[0137] According to a control method according to the third aspect of the present invention, in the invention described in the second aspect, a power supply of a part for performing a process depending on a format of data communicated in the synchronous communication mode is also turned off, so that a power consumption can be reduced.

[0138] According to a control method according to the fourth aspect of the present invention, in the invention described in the first aspect, a connected network is a network in which communication in an asynchronous communication mode and communication in a synchronous communication mode are connected to each other by a bus line which can coexist in a time divisional manner on the same line. For this reason, power required for communication between devices when communication is executed by using the network constituted such that connection is performed by the bus line having the above configuration can be effectively reduced.

[0139] According to the control method described in the fifth aspect of the present invention, in the invention described in the fourth aspect, when a setting of a plug for a synchronous communication mode is in an OFF state, a power supply of a part for executing a communication

process in the synchronous communication mode is turned off. For this reason, the power supply of the part for executing the communication process in the synchronous communication mode can be preferably controlled.

[0140] According to the seventh aspect of the present invention, in the invention described in the fourth aspect, when a connection for synchronous communication with another device in a network is not set, a power supply of a part for executing a communication process in a synchronous communication mode is turned off. For this reason, the power supply of a part for executing the communication process in the synchronous communication mode can be preferably controlled.

[0141] According to a control method described in the ninth aspect of the present invention, in the invention described in the first aspect, when unloading a recording medium is detected, the power supply of the part for executing the communication process in the synchronous communication mode is turned off, and, when the recording medium is loaded, the power supply of the part for executing the communication process in the synchronous communication mode is turned on. For this reason, the power supply of the communication process unit in the synchronous communication mode is ON/OFF-controlled while being linked with loading/unloading the recording medium. For example, when data read from the recording medium is transmitted to the network in the synchronous communication mode, or when data received in the synchronous communication mode through the network is recorded on the recording medium, if these processes cannot be executed, a power supply of a communication process unit in the synchronous communication mode is automatically turned off, and the power supply of the communication process unit in the synchronous communication mode can be preferably controlled in accordance with a state of a device.

[0142] According to a control method described in the eleventh aspect of the present invention, a power supply of only a part for executing a communication process in an asynchronous communication mode is independently controlled, and, for example, when asynchronous communication need not be performed, the power supply of the part can be turned off. Therefore, power may be supplied to the part for executing the communication process in the asynchronous communication mode only when the asynchronous communication must be performed, so that power required for the communication process can be reduced.

[0143] According to a control method described in the twelfth aspect of the present invention, in the invention described in the eleventh aspect, communication in the synchronous communication mode is continuously executed, and, when communication in the asynchronous communication mode need not be performed, the power supply of the part for executing the communication process in the asynchronous communication mode is turned off. For example, as in transmission or the like of video data from a monitoring camera in a synchronous communication mode, continuous data communication is performed in a constant state, and, when control data or the like related to the data communication in the asynchronous communication mode need not be performed, a process for communication can be performed with a small power consumption.

[0144] According to a communication device described in the thirteenth aspect of the present invention, only a power

supply of a first communication process unit for executing a communication process in a synchronous communication mode can be independently controlled, and, for example, when synchronous communication need not be performed, a power supply of only the first communication process unit can be turned off. For this reason, in accordance with a communication state decided by a control unit, a power consumption of the first communication process unit can be turned off to reduce a power consumption.

[0145] According to a communication device described in the fourteenth aspect of the present invention, in the invention described in the thirteenth aspect, by control of the control unit, in a period in which communication in the synchronous communication mode is not executed, the power supply of the first communication process unit is turned off, and power supplies of a second communication process unit and an input/output unit are set in ON states. For this reason, only the second communication process unit may be powered on in the period in which the communication in the synchronous communication mode is not performed, and power required for the communication process can be reduced.

[0146] According to a communication device described in the fifteenth aspect of the present invention, in the invention described in the fourteenth aspect, a data processing unit for performing a process depending on a format of data communicated in the synchronous communication mode is comprised, and, by the control of the control unit, a power supply of the data processing unit is turned off in the period in which the communication in the synchronous communication mode is not executed. For this reason, a power consumption can be reduced.

[0147] According to a communication device described in the sixteenth aspect of the present invention, in the invention described in the thirteenth aspect, a network connected to the input/output unit is a network in which communication in an asynchronous communication mode and communication in a synchronous communication mode are constituted by a bus line which can coexist in a time divisional manner on the same line. For this reason, power required for communication between communication devices for the network constituted such that connection is performed by the bus line having the above configuration can be effectively reduced.

[0148] According to a communication device described in the eighteenth aspect of the present invention, in the invention described in the sixteenth aspect, when a control unit decides that a plug for the synchronous communication mode is set in an OFF state, the control unit turns off the power supply of the first communication unit. For this reason, control of the power supply of the first communication unit for executing the communication process in the synchronous communication mode can be preferably performed.

[0149] According to a communication device described in the twentieth aspect of the present invention, in the invention described in the sixteenth aspect, when a control unit decides that a connection for synchronous communication with another device in a network is not set, the control unit turns off the power supply of the first communication unit. For this reason, control of the power supply of the first communication unit for executing the communication process in the synchronous communication mode can be preferably performed.

[0150] According to a communication device described in the twenty-first aspect of the present invention, in the invention described in the thirteenth aspect, a loading unit on which a recording medium is loaded is comprised, the control unit turns off the power supply of the first communication process unit when the control unit detects unloading the recording medium on the loading unit, and the control unit turns on the power supply of the first communication process unit when the control unit detects loading the recording medium on the loading unit. For this reason, the power supply of the first communication process unit is automatically ON/OFF-controlled while being linked with loading/unloading the recording medium. For example, when data read from the recording medium is transmitted to the network in the synchronous communication mode, or when data received in the synchronous communication mode through the network is recorded on the recording medium, if these processes cannot be executed, the power supply of the communication process unit in the synchronous communication mode is automatically turned off. Therefore, the power supply of the communication process unit in the synchronous communication unit can be preferably controlled in accordance with a state of a device.

[0151] According to a control device described in the twenty-second aspect of the present invention, by controlling a control unit, only a power supply of a second communication process unit for executing a communication process in an asynchronous communication mode can be independently controlled. For example, when the asynchronous communication need not be performed, only the power supply of the second communication process unit can be turned off. Therefore, the power supply of the second communication unit can be turned off to reduce a power consumption in accordance with a state of communication decided by the control unit.

[0152] According to a communication device described in the twenty-third aspect of the present invention, in the invention described in the twenty-second aspect, communication in the synchronous communication mode is continuously executed by the first communication process unit, and, when communication in an asynchronous communication mode need not be performed in the second communication process unit, the control unit turns off the power supply of the second communication process unit. For this reason, for example, as in transmission or the like of video data from a monitoring camera in the synchronous communication mode, continuous data communication is performed in a constant state, and, control data or the like related to the data communication need not be transmitted in the asynchronous communication mode, a process for communication can be performed with a small power consumption.

[0153] Having described preferred embodiments of the invention with reference to the accompanying drawings, it is to be understood that the invention is not limited to those precise embodiments and that various changes and modifications could be effected therein by one skilled in the art without departing from the spirit or scope of the invention as defined in the appended claims.

What is claimed is:

1. A control method for a device connected to a predetermined network and having a first communication process unit for executing communication in an asynchronous com-

munication mode and a second communication process unit for executing communication in a synchronous communication mode, comprising

the power supply control step of controlling a power supply of the second communication process unit for executing a communication process in the synchronous communication mode independently of a power supply of the first communication process unit for executing a communication process in the asynchronous communication mode.

2. The control method according to claim 1, wherein, in the power supply control step,

the power supply of the second communication process unit for executing the communication process in the synchronous communication mode is turned off in a period in which the communication in the synchronous communication mode is not executed, and only a power supply of the first communication process unit for executing the communication process in the asynchronous communication mode is turned on is set in an ON state.

3. The control method according to claim 2, wherein, in the power supply control step,

a power supply of a part for performing a process depending on a format of data communicated in the synchronous communication mode is turned off.

4. The control method according to claim 1, wherein the predetermined network is constituted by a bus line on which communication data in the asynchronous communication mode and communication data in the synchronous communication mode are transmitted such that both the communication data can coexist in a time divisional manner on the same line.

5. The control method according to claim 4, wherein, in the power supply control step,

on the basis of a setting of a plug for the synchronous communication mode, the power supply of the second communication process unit for executing the communication process in the synchronous communication mode.

6. The control method according to claim 5, wherein in the power supply control step,

when the setting of the plug for the synchronous communication mode is in an OFF state, the power supply of the part for executing the communication process in the synchronous communication mode is turned off.

7. The control method according to claim 4, wherein, in the power supply control step,

on the basis of a setting of a connection for synchronous communication with another device in a network, a power supply of a communication process unit for executing the communication process in the synchronous communication mode is controlled.

8. The control method according to claim 7, wherein, in the power supply control step,

when a connection for synchronous communication with another device in a network is not set, the power supply of the part for executing the communication process in the synchronous communication mode is turned off.

9. The control method according to claim 1, wherein the device has loading means for loading a recording medium,

and, in the power supply control step, a power supply of a second communication control unit for executing the communication process in the synchronous communication mode is controlled on the basis of a loading state of the recording medium on the loading means.

10. The control method according to claim 9, wherein, in the power supply control step,

the power supply of the second communication process unit for executing the communication process in the synchronous communication mode is turned off when unloading the recording medium is detected, and

the power supply of the second communication process unit for executing the communication process in the synchronous communication mode is turned on when the recording medium is loaded.

11. A control method for a device connected to a predetermined network and having a first communication process unit for executing communication in a synchronous communication mode and a second communication process unit for executing communication in an asynchronous communication mode, comprising

the power supply control step of controlling a power supply of the second communication process unit for executing a communication process in the asynchronous communication mode independently of a power supply of the first communication process unit for executing a communication process in the synchronous communication mode.

12. The control method according to claim 11, wherein, in the power supply control step,

communication in the synchronous communication mode is continuously executed, and, when communication in the asynchronous communication mode need not be performed, the power supply of the second communication process unit for executing the communication process in the asynchronous communication mode is turned off.

13. A communication device which is connected to a predetermined network and which can perform synchronous communication in a synchronous communication mode through the network and asynchronous communication in the asynchronous communication mode through the network, comprising:

a first communication process unit for performing a communication process in the synchronous communication mode;

a second communication process unit for performing a communication process in the asynchronous communication mode;

an input/output unit for performing inputting/outputting between the first and second communication process units and the network; and

a control unit for controlling the synchronous communication and the asynchronous communication to independently control only the power supply of the first communication process unit.

14. The communication device according to claim 13, wherein the control unit

turns off the power supply of the first communication process unit in a period in which communication in the

synchronous communication mode is not executed to set the power supply of the second communication process unit in an ON state.

15. The communication device according to claim 14, comprising a data processing unit for performing a process depending on a format of data communicated in the synchronous communication mode, and

wherein the control unit turns off a power supply of the data processing unit in the period in which the communication in the synchronous communication mode is not executed.

16. The communication device according to claim 13, wherein, on the network, communication data in the asynchronous communication mode and communication data in the synchronous communication mode are transmitted such that both the communication data can coexist in a time divisional manner on the same line.

17. The communication device according to claim 16, wherein the control unit

turns off the power supply of the first communication control unit on the basis of a setting of a plug for the synchronous communication mode.

18. The communication device according to claim 17, wherein the control unit

turns off the power supply of the first communication process unit when the control unit determines that the setting of the plug for the synchronous communication mode is in an OFF state.

19. The communication device according to claim 16, wherein the control unit

turns off the power supply of the first communication process unit on the basis of a setting of a connection for synchronous communication with another device in the network.

20. The communication device according to claim 19, wherein the control unit

turns off the power supply of the first communication control unit when the control unit determines that the connection for the synchronous communication with another device in the network is not set.

21. The communication device according to claim 13, comprising:

a loading unit for loading a recording medium; and

a loading detection unit for detecting loading/unloading a recording medium on the loading unit, and wherein

when the loading detection unit detects unloading the recording medium on the loading unit, the control unit turns off the power supply of the first communication process unit, and

when the loading detection unit detects loading the recording medium on the loading unit, the control unit turns on the first communication process unit.

22. A communication device which is connected to a predetermined network and which can perform synchronous communication in a synchronous communication mode through the network and asynchronous communication in the asynchronous communication mode through the network, comprising:

a first communication process unit for performing a communication process in the synchronous communication mode;

a second communication process unit for performing a communication process in the asynchronous communication mode;

an input/output unit for performing inputting/outputting between the first and second communication process units and the network; and

a control unit for controlling the synchronous communication and the asynchronous communication so that only the power supply of the second communication process unit can be independently controlled.

23. The communication device according to claim 22, wherein, communication in the synchronous communication mode is continuously executed by the first communication process unit, and, when communication in the asynchronous communication mode need not be performed by the second communication process unit, the control unit turns off the power supply of the second communication process unit.

* * * * *