

(19) World Intellectual Property Organization  
International Bureau



(43) International Publication Date  
18 May 2007 (18.05.2007)

PCT

(10) International Publication Number  
**WO 2007/055781 A1**

(51) International Patent Classification:  
A61F 2/06 (2006.01)

(21) International Application Number:  
PCT/US2006/034311

(22) International Filing Date: 29 August 2006 (29.08.2006)

(25) Filing Language: English

(26) Publication Language: English

(30) Priority Data:  
11/266,587 2 November 2005 (02.11.2005) US

(71) Applicant (for all designated States except US): **CARDIOMIND, INC.** [US/US]; 257 Humboldt Court, Sunnyvale, California 94089 (US).

(72) Inventors; and

(75) Inventors/Applicants (for US only): **TON, Dai, T.** [US/US]; 1514 Mt. Diablo Avenue, Milpitas, California 95035 (US). **GEORGE, William, R.** [US/US]; 435 Oxford Way, Santa Cruz, California 95060 (US). **LICATA, David** [US/US]; P.O. Box 60819, Palo Alto, California 94306 (US).

(74) Agent: **BABA, Edward, J.**; Bozicevic, Field & Francis LLP, 1900 University Avenue, Suite 200, East Palo Alto, California 94303 (US).

(81) Designated States (unless otherwise indicated, for every kind of national protection available): AE, AG, AL, AM, AT, AU, AZ, BA, BB, BG, BR, BW, BY, BZ, CA, CH, CN, CO, CR, CU, CZ, DE, DK, DM, DZ, EC, EE, EG, ES, FI, GB, GD, GE, GH, GM, HN, HR, HU, ID, IL, IN, IS, JP, KE, KG, KM, KN, KP, KR, KZ, LA, LC, LK, LR, LS, LT, LU, LV, LY, MA, MD, MG, MK, MN, MW, MX, MY, MZ, NA, NG, NI, NO, NZ, OM, PG, PH, PL, PT, RO, RS, RU, SC, SD, SE, SG, SK, SL, SM, SV, SY, TJ, TM, TN, TR, TT, TZ, UA, UG, US, UZ, VC, VN, ZA, ZM, ZW.

(84) Designated States (unless otherwise indicated, for every kind of regional protection available): ARIPO (BW, GH, GM, KE, LS, MW, MZ, NA, SD, SL, SZ, TZ, UG, ZM, ZW), Eurasian (AM, AZ, BY, KG, KZ, MD, RU, TJ, TM), European (AT, BE, BG, CH, CY, CZ, DE, DK, EE, ES, FI, FR, GB, GR, HU, IE, IS, IT, LT, LU, LV, MC, NL, PL, PT, RO, SE, SI, SK, TR), OAPI (BF, BJ, CF, CG, CI, CM, GA, GN, GQ, GW, ML, MR, NE, SN, TD, TG).

**Published:**

- with international search report
- before the expiration of the time limit for amending the claims and to be republished in the event of receipt of amendments

For two-letter codes and other abbreviations, refer to the "Guidance Notes on Codes and Abbreviations" appearing at the beginning of each regular issue of the PCT Gazette.

(54) Title: TWIST-DOWN IMPLANT DELIVERY TECHNOLOGIES

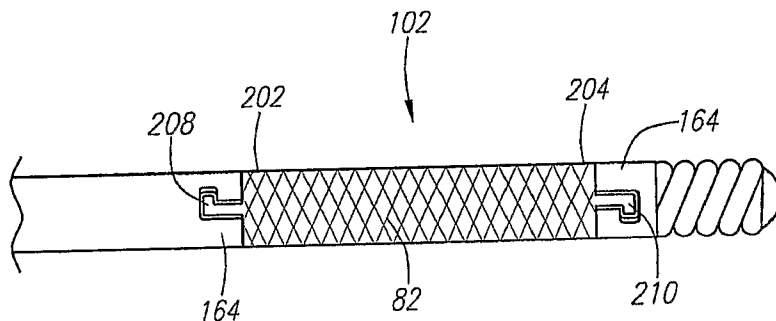

(57) Abstract: Medical devices and methods for delivery or implantation of tubular prostheses within hollow body organs and vessels or other luminal anatomy are disclosed. A prosthesis is held in a compressed form upon an inner wire of a delivery guide by twisting the device. The subject technologies may be used in the treatment of atherosclerosis in stenting procedures or for other purposes.

WO 2007/055781 A1

## TWIST-DOWN IMPLANT DELIVERY TECHNOLOGIES

## BACKGROUND

Implants such as stents and occlusive coils have been used in patients for a wide variety of reasons. One of the most common "stenting" procedures is carried out in connection with the treatment of atherosclerosis, a disease which results in a narrowing and stenosis of body lumens, such as the coronary arteries. At the site of the narrowing (i.e., the site of a lesion) a balloon is typically dilatated in an angioplasty procedure to open the vessel. A stent is set in apposition to the interior surface of the lumen in order to help maintain an open passageway. This result may be affected by means of scaffolding support alone or by virtue of the presence of one or more drugs carried by the prosthesis to aid in the prevention of restenosis.

Various stent designs exist and are in use today, but self-expandable and balloon-expandable stent systems and their related deployment techniques are now predominant. Examples of currently available self-expandable stents are the Magic WALLSTENT® stents and Radius stents (Boston Scientific). The Cypher® stent (Cordis Corporation) is a commonly used balloon-expandable stent. Additional self-expanding stent background is presented in: "An Overview of Superelastic Stent Design," *Min. Invas Ther & Allied Technol* 822: 9(3/4) 235-246, "A Survey of Stent Designs," *Min. Invas Ther & Allied Technol* 822: 11(4) 137-147, and "Coronary Artery Stents: Design and Biologic Considerations," *Cardiology Special Edition*, 823: 9(2) 9-14, "Clinical and Angiographic Efficacy of a Self-Expanding Stent" *Am Heart J* 823: 145(5) 868-874.

Because self-expanding prosthetic devices need not be set over a balloon (as with balloon-expandable designs), self-expanding stent delivery systems can be designed to a relatively smaller outer diameter than their balloon-expandable counterparts. As such, self-expanding stents may be better suited to reach the smallest vasculature or achieve access in more difficult cases. To realize such benefits, however, there continues to be a need in developing improved stents and stent delivery systems.

The present invention offers a stent and system having a space-efficient mode of stent delivery.

## SUMMARY

Variations of the invention hold a radially-expandable prosthesis (such as a stent) in a compressed configuration for delivery either with or without the use of a tubular restraint covering at least a portion of the prosthesis body. By employing a twist-down mode for collapsing the diameter of the stent, the system does not require a sleeve to retain the stent

PCT/US2006/034311

or, if a sleeve is provided, the stent does not strain against it as would otherwise be the case. As discussed herein, stents used in the inventive systems have projections that include interface features for mating or seating with complimentary features on the delivery device that allow for the stent to be delivered in a collapsed (twisted-down) state and, when desired, expanded for implantation.

- 1006] Delivery systems according to the present invention may include use-manipulable element(s) that allow for actuation of the subject system. These elements may include handles, finger actuators, or other means as commonly known and used for such devices. They may allow for rotation, axial movement, withdrawal of a sheath, or other manipulations required to deploy or load a prosthesis as discussed herein.
- 1007] Stents employed in the systems are tubular-type members (i.e., they are not coil stents). The stents are lattice, cage or successive linked ring type structures or they are mesh-like woven or assembled bodies. Most often, the stents are produced by cutting round tubing. However, other means or modes of manufacture are possible as well.
- 1008] In one variation of the delivery system, a body or shaft of a delivery guide is provided in the form of a tube or sleeve that includes projections in the form of hooks at a distal end (where the hook portion extends out-of-plane). The body is advantageously made of hypotubing in order to manufacture hooks integral thereto. Complementary hooks may be formed distal thereto and supported by a core member over which the sleeve rides. The distal hooks may be formed in connection with a ring or be provided otherwise.
- 1009] Similar construction may be employed in another variation of the invention, in which the hooks or hook-type projection features are oriented substantially circumferentially. In this fashion, interlocking ends of the stent and hooks lie next to one another or occupy the same circumferential region. In any case, the hooks (typically numbering at least two per side of the implant to balance forces) are dimensioned with a prong and recess suited for receipt of a stent. The hooks may be J-shaped, T-shaped or otherwise configured as elaborated upon below.
- 1010] In yet another variation of the invention, one or more ends of the stent and interfacing delivery system may include axially-directed interface features. Rather than utilizing an interlocking interface, the projections employed in these variations of the invention provide lateral capture and axial disengagement without a requirement for out-of-plane movement.
- 1011] Irregardless of the manner in which the respective interface or mating portions are configured, a twisting mode of stent compression and retention is employed. Stent release is accomplished by releasing the twist or torque (possibly tension as well) that holds a given stent in a collapsed profile or by other means including radial release and foreshortening of

~~PCT/US06/24311~~  
of the stent to pull out of the interface member to allow it to then unwind from the twisted, collapsed profile.

- 012] The combination of interfacing stent and delivery system features may work alone, or in conjunction with supplemental hold-down features. Sleeve and band type members are discussed herein, though other options are possible as well. For example, generic concepts expressed herein may be supported and/or practiced employing variations of the invention as set forth in U.S. Patent Application Serial No. 11/265,999, entitled "Indirect-Release Implant Delivery Systems," filed on even date herewith and incorporated by reference in its entirety for this or any other purpose.
- 013] Methodology described in association with the devices disclosed and implicit to their use also forms part of the invention. Such methodology may include that associated with completing an angioplasty, bridging an aneurysm, deploying radially-expandable anchors for pacing leads or an embolic filter, or placement of a prosthesis within neurovasculature, an organ selected from the kidney and liver, within reproductive anatomy such as selected vasdeferens and fallopian tubes or other applications.

#### DEFINITIONS

- 014] The term "stent" as used herein includes any stent, such as coronary artery stents, other vascular prosthesis, or other radially expanding or expandable prosthesis or scaffold-type implant suitable for the noted treatments or otherwise. Exemplary structures include wire mesh or lattice patterns and coils, though others may be employed in the present invention.
- 015] A "self-expanding" stent as used herein is a scaffold-type structure (serving any of a number of purposes) that expands from a reduced-diameter (be it circular or otherwise) configuration to an increased-diameter configuration. The mechanism for shape recover may be elastic or pseudoelastic. While it is generally desirable to employ an alloy (such as nickel-titanium, or Nitinol alloy) set for use as a superelastic alloy, it may alternatively employ thermal shape memory properties to drive expansion upon release.
- 016] A "wire" as used herein generally comprises a common metallic member. However, the wire may be coated or covered by a polymeric material (e.g., with a lubricious material such as TEFLON®, i.e., PolyTetraFluoroEthylene or PTFE) or otherwise. Still further, the "wire" may be a hybrid structure with metal and a polymeric material (e.g., Vectran™, Spectra™, Nylon, etc.) or composite material (e.g., carbon fiber in a polymer matrix). The wire may be a filament, bundle of filaments, cable, ribbon or in some other form. It is generally not hollow.
- 017] A "corewire" or "core member" may be use interchangeably and, as referred to herein, has a wire form and may be made from any biocompatible material including; but not limited

PCT/US06/34311

to, stainless steel and any of its alloys; titanium alloys, e.g., Ni-Ti alloys; other shape memory alloys (i.e., SMAs); tantalum; polymers, e.g., polyethylene and copolymers thereof, polyethylene terephthalate or copolymers thereof, nylon, silicone, polyurethane fluoropolymers, poly (vinylchloride), and combinations thereof.

- 018]** An "inner member" as disclosed herein includes a core member or a corewire and a cladding, cladding sections or a cladding layer which covers or surrounds at least a portion of the core member or corewire. The two may be bonded together or otherwise connected/interconnected.
- 019]** A "cladding" as referred to herein means an outer layer of material which is bonded to a core member or a core wire. As with the "wire" discussed above, the material defining the cladding may be metallic, polymeric or a hybrid of thereof or a composite material. The cladding material may have the same flexibility or greater flexibility than the member to which it is bonded to so as not impeded the member's flexibility.
- 020]** A "hypotube" or "hypotubing" as referred to herein means small diameter tubing in the size range discussed below, generally with a thin wall. The hypotube may specifically be hypodermic needle tubing. Alternatively, it maybe wound or braided cable tubing, such as provided by Asahi Intec Co., Ltd. or otherwise. As with the "wire" discussed above, the material defining the hypotube may be metallic, polymeric or a hybrid of metallic and polymeric or composite material.
- 021]** A "sleeve" as referred to herein may be made of hypotubing or otherwise constructed. The sleeve may be a tubular member, or it may have longitudinal opening(s). It is an outer member, able to slidingly receive and hold at least a portion of an inner member.
- 022]** An "atraumatic tip" may comprise a plurality of spring coils attached to a tapered wire section. At a distal end of the coils typically terminate with a bulb or ball that is often made of solder. In such a construction, the coils and/or solder are often platinum alloy or another radiopaque material. The coils may also be platinum, or be of another material. In the present invention, the wire section to which the coils are attached may be tapered, but need not be tapered. In addition, alternate structures are possible. In one example, the atraumatic tip may comprise a molded tantalum-loaded 35 durometer Pebax™ tip. However constructed, the atraumatic tip may be straight or curved, the latter configuration possibly assisting in directing or steering the delivery guide to a desired intravascular location.
- 023]** To "connect" or to have or make a "connection" between parts refers to fusing, bonding, welding (by resistance, laser, chemically, ultrasonically, etc.), gluing, pinning, crimping, clamping or otherwise mechanically or physically joining, attaching or holding components together (permanently or temporarily).

~~PCT/US2006/034311~~

024] To "bond" or form a "bonding" between structures refers to forming an intimate contact between the structures, typically where the contact is intended to be permanent. The bond or bonding may be achieved by any known means and process including, but not limited to, pressure rolling, extruding, drawing, swaging and adhesion.

025] "Radiopaque markers" are understood to be markers or features of the various delivery system components, corewire or implant that may be employed to facilitate visualization of the system components. As such, various platinum (or other radiopaque material) bands or other markers (such as tantalum plugs) may be variously incorporated into the system. Alternatively, or additionally, the stent may be made of radiopaque material or incorporate them. Especially where the stent employed may shorten somewhat upon deployment, it may also be desired to align radiopaque features with the expected location (relative to the body of the inner member) of the stent upon deployment. A filter used with the subject devices may also be made of radiopaque material for the same reasons.

026] "Releaseably locked" or "lockable" is understood to mean that the lockable components may be prevented from accidentally moving. For example, a handle may be releasably locked to a delivery guide by use of some mechanical stop or fitting (e.g., such as a collet that must be loosened, a latch that must be disengaged, a key that must be removed, etc.). Many common examples of mechanical stops or fittings are found in medical devices where pre-mature actuation of one or more components has the potential to cause trauma to a patient.

#### BRIEF DESCRIPTION OF THE DRAWINGS

027] The Figures shown herein are not necessarily drawn to scale, with some components and features being exaggerated for clarity. Each of the Figures diagrammatically illustrates aspects of the invention. Of these:

Fig. 1 shows a heart in which its vessels may be the subject of one or more angioplasty and stenting procedures;

Fig. 2A shows an expanded stent cut pattern as may be used in producing a stent according to a first aspect of the invention; Fig. 2B shows a stent cut pattern for a second stent produced according to another aspect of the present invention;

Fig. 3A shows an expanded stent cut pattern as may be used in producing a stent according to a first aspect of the invention; Fig. 3B shows a stent cut pattern for a second stent produced according to another aspect of the present invention;

PCT/US06/34311

Figs. 4A-4L illustrate stent deployment methodology to be carried out with the subject delivery guide member;

Fig. 5 provides an overview of a delivery system incorporating a tubular member according to the present invention;

Fig. 6 illustrates an example of a variation of a delivery system of the present invention without the prosthesis (or in an unloaded configuration);

Fig. 7 illustrates an example of a stent for use with the present invention;

Figs. 8A-8F illustrates various projections of the mating portions of stents in accordance with the present invention;

Figs. 9A-9C depicts variations of the implant delivery system;

Fig. 10A illustrates an additional variation of an implant delivery system;

Fig. 10B illustrates an additional variation of an implant delivery system having a moveable sheath over the proximal portion of the delivery system;

Figs. 11A-11C illustrate an additional variation of an implant delivery system having a sleeve covering the stent;

Figs. 11D-11E illustrate variations of sleeves for use with the system;

Figs. 12A-12B show side views of an implant delivery system of the present invention in an unloaded and loaded configuration respectively;

Figs. 13A-13B shows another variation of an implant delivery system according to the principles of the present invention;

Fig. 14A is a partial sectional view of the end of a stent and corresponding features of a delivery guide interface; and

Fig. 14B is an end view of the members shown in Fig. 14A.

Variation of the invention from the examples pictured is, of course, contemplated.

## DETAILED DESCRIPTION

028] Various exemplary embodiments of the invention are described below. Reference is made to these examples in a non-limiting sense. They are provided to illustrate more broadly applicable aspects of the present invention. Various changes may be made to the invention described and equivalents may be substituted without departing from the true spirit and scope of the invention. In addition, many modifications may be made to adapt a particular situation, material, composition of matter, process, process act(s) or step(s) to the objective(s), spirit or scope of the present invention. All such modifications are intended to be within the scope of the claims made herein.

029] In light of this framework, Fig. 1 shows a heart 2 in which its vessels may be the subject of one or more angioplasty and/or stenting procedures. To date, however, significant

~~PCT/US2006/034311~~

difficulty or impossibility is confronted in reaching smaller coronary arteries 4. If a stent and a delivery system could be provided for accessing such small vessels and other difficult anatomy, an additional 20 to 25% coronary percutaneous procedures could be performed with such a system. Such potential offers opportunity for huge gains in human healthcare and a concomitant market opportunity – with the further benefit of avoiding loss of income and productivity of those treated.

030] Features of the present invention are uniquely suited for a system able to reach small vessels (though use of the subject systems is not limited to such a setting.) By “small” coronary vessels, it is meant vessels having an inside diameter from between about 1.5 to 2 mm and up to about 3 mm in diameter. These vessels include, but are not limited to, the Posterior Descending Artery (PDA), Obtuse Marginal (OM) and small diagonals. Conditions such as diffuse stenosis and diabetes produce situations that represent other access and delivery challenges that can be addressed with a delivery system according to the present invention. Other extended treatment areas addressable with the subject systems include vessel bifurcations, chronic total occlusions (CTOs), and prevention procedures (such as in stenting of vulnerable plaque).

031] It may be preferred to use a drug eluting stent (DES) in such an application to aid in preventing restenosis. A review of suitable drug coatings and available vendors is presented in “DES Overview: Agents, release mechanism, and stent platform” a presentation by Campbell Rogers, MD incorporated by reference in its entirety. However, bare-metal stents may be employed in the present invention.

032] Examples of various therapeutic agents that may be used in or on the subject prosthesis include, but are not limited to, antibiotics, anticoagulants, antifungal agents, anti-inflammatory agents, antineoplastic agents, antithrombotic agents, endothelialization promoting agents, free radical scavengers, immunosuppressive agents, antiproliferative agents, thrombolytic agents, and any combination thereof. The therapeutic agent may be coated onto the implant, mixed with a biodegradable polymer or other suitable temporary carrier and then coated onto the implant, or, when the implant is made from a polymeric material dispersed throughout the polymer. The agent can be directly applied to the stent surface(s), or introduced into pockets or an appropriate matrix set over at least an outer portion of the stent.

033] While some might argue that the particular role and optimal usage of self expanding stents has yet to be defined, they offer an inherent advantage over balloon expandable stents. The latter type of devices produce “skid mark” trauma (at least when delivered uncovered upon a balloon) and are associated with a higher risk of end dissection or barotraumas



~~PCT/US06/34311~~

caused at least in part by high balloon pressures and related forces when deforming a balloon-expandable stent for deployment.

034] Yet, with an appropriate deployment system, self-expanding stents may offer one or more of the following advantages over balloon-expandable models: 1) greater accessibility to distal, tortuous and small vessel anatomy – by virtue of decreasing crossing diameter and increasing compliance relative to a system requiring a deployment balloon, 2) sequentially controlled or “gentle” device deployment, 3) use with low pressure balloon pre-dilatation (if desirable) to reduce barotraumas, 4) strut thickness reduction in some cases reducing the amount of “foreign body” material in a vessel or other body conduit, 5) opportunity to treat neurovasculature – due to smaller crossing diameters and/or gentle delivery options, 6) the ability to easily scale-up a successful treatment system to treat larger vessels or vice versa, 7) a decrease in system complexity, offering potential advantages both in terms of reliability and system cost, 8) reducing intimal hyperplasia, and 9) conforming to tapering anatomy – without imparting complimentary geometry to the stent (though this option exists as well).

035] At least some of these noted advantages may be realized using a stent 10 as shown in Fig. 2A. The stent pattern pictured is well suited for use in small vessels. It may be collapsed to an outer diameter of about 0.018 inch (0.46 mm), or even smaller to about 0.014 inch (0.36 mm) - including the restraint/joint used to hold it down - and expanded to a size (fully unrestrained) between about 1.5 mm (0.059 inch) or 2 mm (0.079 inch) or 3 mm (0.12 inch) and about 3.5 mm (0.14 inch).

036] In use, the stent will be sized so that it is not fully expanded when fully deployed against the wall of a vessel in order to provide a measure of radial force thereto (i.e., the stent will be “oversized” as discussed above). The force will secure the stent and offer potential benefits in reducing intimal hyperplasia and vessel collapse or even pinning dissected tissue in apposition.

037] Stent 10 preferably comprises NiTi that is superelastic at or below room temperature (i.e., as in having an Af as low as 15 degrees C or even 0 degrees C). Also, the stent is preferably electropolished to improve biocompatibility and corrosion and fatigue resistance. The stent may be a DES unit as referenced above. The stent may be coated with gold and/or platinum to provide improved radiopacity for viewing under medical imaging.

038] For a stent able to collapse to an outer diameter of about 0.012 inches and expand to about 3.5 mm, the thickness of the NiTi is about 0.0025 inch (0.64 mm). Such a stent is designed for use in a 3 mm vessel or other body conduit, thereby providing the desired radial force in the manner noted above. Further information regarding radial force parameters in coronary stents may be noted in the article, “Radial Force of Coronary Stents: A Comparative

Analysis," Catheterization and Cardiovascular Interventions 46: 380-391 (1999), incorporated by reference herein in its entirety.

- 039] In one manner of production, the stent in Fig. 2A is laser or EDM cut from round NiTi tubing, with the flattened-out pattern shown wrapping around the tube as indicated by dashed lines. In such a procedure, the stent is preferably cut in its fully-expanded shape. By initially producing the stent to full size, the approach allows cutting finer details in comparison to simply cutting a smaller tube with slits and then heat-expanding/annealing it into its final (working) diameter. Avoiding post-cutting heat forming also reduces production cost as well as the above-reference effects.
- 040] Regarding the finer details of the subject stent, as readily observed in the detail view provided in Fig. 2B, necked down bridge sections 12 are provided between axially/horizontally adjacent struts or arms/legs 14, wherein the struts define a lattice of closed cells 16. Such a closed cell design facilitate twist-down because the otherwise free ends of an open ended cell (or successive ring) design have a tendency to lift-off in a radial direction due to complex stress distributions.
- 041] In certain variations of the invention, however, the bridge sections can be strategically separated or opened as indicated by the broken lines in Fig. 2A. Doing so disrupts the closed cell pattern discussed above, but may increase stent conformability to tortuous anatomy. One situation in which such modification may be useful is in those variations of the invention employing a sleeve or sheath overlying the stent. In any case, to facilitate such tuning of the stent, the bridge sections are preferably sufficiently long so that fully rounded ends may be formed internally to the lattice just as shown at terminal ends 18 of the cells not carrying stent/delivery system interface features.
- 042] As for the optional double-concave profile of each strut bridge 12 shown, this form is advantageous in that it reduces material width (relative to what would otherwise be presented by a parallel side profile) to improve flexibility and thus trackability and conformability of the stent within the subject anatomy while still maintaining the option for separating/breaking the cells apart. Whether cut to provide rounded end portions or adjoined by a bridge section 12, strut junction sections 28 connect circumferentially or vertically adjacent struts (as illustrated). Where no bridge sections are provided, the junction sections can be unified between horizontally adjacent stent struts as indicated in region 30.
- 043] Further optional features of stent 10 are employed in the strut junction sections 28 of the design. Specifically, strut ends 20 increase in width relative to medial strut portions 22. Such a configuration distributes bending (during collapse of the stent) preferentially toward the mid region of the struts. For a given stent diameter and deflection, longer struts allow for lower stresses within the stent (and, hence, a possibility of higher compression ratios).

PCT/US06/34311

Shorter struts allow for greater radial force (and concomitant resistance to a radially applied load) upon deployment.

- 044] In order to increase stent compliance so that it collapses as much as possible, accommodation is made for the stiffer strut ends 20 provided in the design shown in Fig. 2A. Namely, the gap 24 between the strut ends 22 is set at a smaller angle as if the stent were already partially collapsed in that area. Thus, the smaller amount of angular deflection that occurs at ends 20 can bring the sections parallel (or nearly so) when the strut medial portions 22 are so-arranged. In the variation of the invention in Fig. 2A, radiused or curved sections 26 provide a transition from a medial strut angle  $\alpha$  (ranging from about 85 degrees to about 60 degrees) to an end strut angle  $\beta$  (ranging from about 30 to about 0 degrees) at the strut junctions 28 and/or extensions therefrom.
- 045] In addition, it is noted that gap 24 an angle  $\beta$  may actually be configured to completely close prior to fully collapsing angle  $\alpha$ . The stent shown is not so-configured. Still, the value of doing so would be to limit the strains (and hence, stresses) at the strut ends 22 and cell end regions 18 by providing a physical stop to prevent further strain.
- 046] In the detail view of Fig. 2B, angle  $\beta$  is set at 0 degrees. The gap 24 defined thereby by virtue of the noticeably thicker end sections 20 at the junction result in very little flexure along those lever arms. The strut medial portions are especially intended to accommodate bending. In addition, a hinging effect at the corner or turn 32 of junction section 28 may allow the strut to swing around angle  $\alpha$  to provide the primary mode for compression of the stent.
- 047] Additional features of interest in the stent design include near and far delivery system interface mating portions 208 and 210, respectively. These elements are formed within projections 212 that may be integral to the prosthesis 82 (e.g., when the prosthesis is constructed from a single tube of material, or when a number of wire-type elements are woven to form the body where the ends of the elements form the prosthesis). Alternatively, the projections may be affixed or connected to the stent (e.g., via welding, adhesive bonding, fastening, etc.). In another variation of the invention, the projections may comprise polymeric material that is coated onto the prosthesis 82. Other modes of construction are possible as well. Further details of the projections and respective mating portions are discussed in detail below. Suffice it to say here that elements are sufficiently "floppy" and/or rounded to offer an atraumatic interface with opposing tissue.
- 048] The stent pattern shown in Fig. 3A and detailed in Fig. 3B offers certain similarities as well as some major differences from the stent pattern presented in Figs. 2A and 2B. As in the variation above, stent 82 includes necked down bridge sections 42 provided between adjacent struts or arms/legs 44, wherein the struts define a lattice of closed cells 46. In addition,

PCT/US2006/034311

terminal ends 48 of the cells are preferably rounded-off so as to be atraumatic, as may mating portions 208, 210.

049] Furthermore, the bridge sections 42 of stent 82 can be separated for compliance purposes. In addition, they may be otherwise modified (e.g., as described above) or even eliminated. Also, in each design, the overall dimensions of the cells and indeed the number of cells provided to define axial length and/or diameter may be varied (as indicated by the vertical and horizontal section lines in Fig. 3A).

050] Like the previous stent design, strut ends 50 may offer some increase in width relative to medial strut portions 52. However, as shown in Fig. 3B, as compared to Fig. 2B, the angle  $\beta$  is relatively larger. Such a configuration is not concerned with developing a hinge section and a relatively stiffer outer strut section. Instead, angle  $\beta$  in the Fig. 3A/3B design is meant to collapse and the strut ends are meant to bend in concert with the medial strut portions so as to essentially straighten-out upon collapsing the stent, generally forming tear-drop spaces between adjacent struts. This approach offers a stress-reducing radius of curvature where struts join, and maximum stent compression.

051] The "S" curves defined by the struts are produced in a stent cut to a final or near final size (as shown in Figs. 3A and 3B). The curves are preferably determined by virtue of their origination in a physical or computer model that is expanded from a desired compressed shape to the final expanded shape. So derived, the stent can be compressed or collapsed under force to provide an outer surface profile that is as solid or smooth and/or cylindrical as possible or feasible. Such action is enabled by distribution of the stresses associated with compression to generate strains to produce the intended compressed and expanded shapes. This effect is accomplished in a design unaffected by one or more expansion and heat setting cycles that otherwise deteriorate the quality of the superelastic NiTi stent material. Further details regarding the "S" stent design and alternative stent constructions as may be used in the present invention are disclosed in U.S. Provisional Patent Application Serial No. 60/619,437, entitled, "Small Vessel Stent Designs", filed October 14, 2004 and incorporated herein by reference in its entirety.

052] For use in the present invention, it has been discovered that the design in Figs. 3A and 3B not only compresses to a closely cylindrical profile, but that it maintains such a shape when twisted. Not to be bound by a particular theory, but it is believed that this device excels in the twisting mode because of the extremely even stress distribution it offers when simply compressed. As such, while each of the stent types shown in Figs. 2A-3B may be employed in any of the systems described herein, the latter design may be preferred. Furthermore, the manner in which the "S" curves have been generated may be extended such that the analysis used to generate the as-cut (or near to as-cut) structures specifically accounts for the twisting

~~PCT/US06/34311~~

the design will be subject to in certain variations of the invention. Specifically, physical or computational models may be employed in expanding a stent from an idealized compressed state to generate the desired uncompressed stent geometry.

0053] However derived, in order that the stent pack cleanly when twisted, it may be desired to pre-curve its shape. That is to say, the stent may be configured so that when it is twisted, its members go from a pre-twisted shape to a straightened configuration as shown. The amount of shaping to account for hold-down twist, may be in the form of a simple bias or helix, S-curves or other shape(s).

0054] Since each of the above stent designs account for problematic strain (and in the latter case actually uses the same to provide an improved compressed profile), very high compression ratios of the stent may be achieved from about 5X to about 10X or above. Moreover, they can be twisted a number of times to maintain a compressed delivery profile. The number of twists required for such action will vary depending on stent diameter and length. For a 28 mm stent sized to treat 3.0 mm vessels, between three and four twists may be desired. Similar diameter, shorter stents will require proportionally fewer rotations, as will generally smaller diameter stents.

0055] Regardless of the design selected, it is noted that each of them exhibit significant foreshortening when expanding from a compressed profile. Essentially, the angle change of the struts relative to the central axis of the tubular body accounts for change in length. The amount of foreshortening experienced will, thus, depend on a combination of factors: strut length and angle as well as the number of repeating units within the design. The manner in which the resultant foreshortening is put to use in the present invention is elaborated upon below.

0056] Before this discussion, however, it is noted that systems according to the present invention are advantageously sized to correspond to existing guidewire sizes. For example, the system may have about a 0.014 (0.36mm), 0.018 (0.46mm), 0.022 (0.56mm), 0.025 (0.64mm) inch crossing profile. Of course, intermediate sizes may be employed as well, especially for full-custom systems. Still further, it is contemplated that the system sizing may be set to correspond to French (FR) sizing. In that case, system sizes contemplated range at least from about 1 to about 2 FR, whereas the smallest known balloon-expandable stent delivery systems are in the size range of about 3 to about 4 FR. In instances where the overall device crossing profile matches a known guidewire size, they may be used with off-the-shelf components such as balloon and microcatheters.

0057] At least when produced in the smallest sizes (whether in an even/standard guidewire or FR size, or otherwise), the system enables a substantially new mode of stent deployment in which delivery is achieved through an angioplasty balloon catheter or small microcatheter

PCT/US06/34311

lumen. Further discussion and details of "through the lumen" delivery is presented in U.S. Patent Application Serial No. 10/746,455 "Balloon Catheter Lumen Based Stent Delivery Systems" filed on December 24, 2003 and its PCT counterpart US2004/008909 filed on March 23, 2004, each incorporated by reference in its entirety.

- 058] In larger sizes (i.e., up to about 0.035 inch crossing profile or more), the system is most applicable to peripheral vessel applications as elaborated upon below. Yet, even in "small vessel" cases or applications (where the vessel to be treated has a diameter up to about 3.0 mm), it may also be advantageous to employ a stent delivery system sized at between about 0.022 to about 0.025 inch in diameter. Such a system can be used with catheters compatible with 0.022 and/or 0.025 inch diameter guidewires.
- 059] While such a system may not be suitable for reaching the very smallest vessels, this variation of the invention is quite advantageous in comparison to known systems in reaching the larger of the small vessels (i.e., those having a diameter of about 2.5 mm or larger). By way of comparison, among the smallest known over-the-guidewire delivery systems are the Micro-Driver™ by Medtronic and Pixel™ systems by Guidant. These are adapted to treat vessels between 2 and 2.75 mm, the latter system having a crossing profile of 0.036 inches (0.91 mm). A system described in U.S. Patent Publication No. 2002/0147491 for treating small vessels is supposedly capable of downsizing to 0.026 inch (0.66 mm) in diameter. Furthermore, because the core member of the subject device can be used as a guidewire (in one fashion or another) after stent delivery, the present invention offers further advantages in use as elaborated upon below.
- 060] As referenced above, it may be desired to design a variation of the subject system for use in deploying stents in larger, peripheral vessels, biliary ducts or other hollow body organs. Such applications involve a stent being emplaced in a region having a diameter from about 3.5 to 13 mm (0.5 inch). In which case, a 0.035 to 0.039 inch (3 FR) diameter crossing profile system is advantageously provided in which the stent expands (unconstrained) to a size between about roughly 0.5 mm and about 1.0 mm greater than the vessel or hollow body organ to be treated. Sufficient stent expansion is easily achieved with the exemplary stent patterns shown in Figs. 2A/2B or 3A/3B.
- 061] Again, as a matter of comparison, the smallest delivery systems known to applicants for stent delivery in treating such larger-diameter vessels or biliary ducts is a 6 FR system (nominal 0.084 inch outer diameter), which is suited for use in an 8 FR guiding catheter. Thus, even in the larger sizes, the present invention affords opportunities not heretofore possible in achieving delivery systems in the size range of a commonly used guidewire, with the concomitant advantages discussed herein.

- 062] As for the manner of using the inventive system as optionally configured, Figs. 4A-4L illustrate an exemplary angioplasty procedure. Still, the delivery systems and stents or implants described herein may be used otherwise – especially as specifically referenced herein.
- 063] Turning to Fig. 4A, it shows a coronary artery 60 that is partially or totally occluded by plaque at a treatment site/lesion 62. Into this vessel, a guidewire 70 is passed distal to the treatment site. In Fig. 4B, a balloon catheter 72 with a balloon tip 74 is passed over the guidewire, aligning the balloon portion with the lesion (the balloon catheter shaft proximal to the balloon is shown in cross section with guidewire 70 therein).
- 064] As illustrated in Fig. 4C, balloon 74 is expanded (dilatated or dialated) in performing an angioplasty procedure, opening the vessel in the region of lesion 62. The balloon expansion may be regarded as “predilatation” in the sense that it will be followed by stent placement (and optionally) a “postdilatation” balloon expansion procedure.
- 065] Next, for compatible systems (i.e., systems able to pass through a balloon catheter lumen) the balloon is at least partially deflated and passed forward, beyond the dilate segment 62' as shown in Fig. 4D. At this point, guidewire 70 is removed as illustrated in Fig. 4E. It is exchanged for a delivery guide member 80 carrying stent 82 as further described below. This exchange is illustrated in Figs. 4E and 4F.
- 066] However, it should be appreciated that such an exchange need not occur. Rather, the original guidewire device inside the balloon catheter (or any other catheter used) may be that of item 80, instead of the standard guidewire 70 shown in Fig. 4A. Thus, the steps depicted in Figs. 4E and 4F (hence, the figures also) may be omitted.
- 067] Alternatively, the exchange of the guidewire for the delivery system may be made before the dilatation step. Yet another option is to exchange the balloon catheter used for predilatation for a fresh one to effect postdilatation.
- 068] In addition, there may be no use in performing the step in Fig. 4D of advancing the balloon catheter past the lesion, since such placement is merely for the purpose of avoiding disturbing the site of the lesion by moving a guidewire past the same. Fig. 4G illustrates the next act in either case. Particularly, the balloon catheter is withdrawn so that its distal end 76 clears the lesion. Preferably, delivery guide 80 is held stationary, in a stable position. After the balloon is pulled back, so is delivery device 80, positioning stent 82 where desired. Note, however, that simultaneous retraction may be undertaken, combining the acts depicted in Figs. 4G and 4H. Whatever the case, it should also be appreciated that the coordinated movement will typically be achieved by virtue of skilled manipulation by a doctor viewing one or more radiopaque features associated with the stent or delivery system under medical imaging.

~~PCT/US06/34311~~

- 069] Once placement of the stent across from dilated segment 62' is accomplished, stent deployment commences. The manner of deployment is elaborated upon below. Upon deployment, stent 82 assumes an at least partially expanded shape in apposition to the compressed plaque as shown in Fig. 4I. Next, the aforementioned postdilatation may be effected as shown in Fig. 4J by positioning balloon 74 within stent 82 and expanding both. This procedure may further expand the stent, pushing it into adjacent plaque – helping to secure each.
- 070] Naturally, the balloon need not be reintroduced for postdilatation, but it may be preferred. Regardless, once the delivery device 80 and balloon catheter 72 are withdrawn as in Fig. 4K, the angioplasty and stenting procedure at the lesion in vessel 60 is complete. Fig. 4L shows a detailed view of the emplaced stent and the desired resultant product in the form of a supported, open vessel.
- 071] Furthermore, it is to be recognized that the subject invention may be practiced to perform “direct stenting.” That is, a stent may be delivered alone to maintain a body conduit, without preceding balloon angioplasty. Likewise, once one or more stents are delivered with the subject system (either by a single system, or by using multiple systems) the post-dilatation procedure(s) discussed above are merely optional. In addition, other endpoints may be desired such as implanting an anchoring stent in a hollow tubular body organ, closing off an aneurysm, delivering a plurality of stents, etc. In performing any of a variety of these or other procedures, suitable modification will be made in the subject methodology. The procedure shown is depicted merely because it illustrates a preferred mode of practicing the subject invention, despite its potential for broader applicability.
- 072] Returning to Fig. 4L, the stent 82 comprises a near end 202, a far end 204 and a support structure 206 extending therebetween. The support structure 206 is configured to reduce in diameter upon rotation of the near end 202 relative to the far end 204. The stent 82 further comprises projections 212 that allow the stent to be retained upon the delivery system when in a twist-down or compressed state. The projections 212 comprise a near mating portion 208 and a far mating portion 210 that permit retention of the prosthesis 82 on a delivery system when the ends are rotated relative to one another.
- 073] A given implant may have a number of projections 212, each having various shapes rather than having a single configuration. Typically, at least two projections will be provided on each side of the stent. When not every stent crown is capped by a projection, the projections are advantageously spaced substantially equally about the perimeter of the stent to evenly distribute loads upon the stent. In which case, the projections may be aligned with one another along the axis of the stent as shown in Fig. 4L or staggered about its axis of the stent. More typically, each crown will terminate with a projection and mating features. In this



PCT/US2006/034311

manner, the stent can be fully constrained without members tending to lift-off the delivery guide in a pure twisting mode of diameter reduction for delivery. Still further, it is contemplated that the number of crowns may be reduced by taking out adjacent arm sections to turn what was a four-crown design on each end into a two-crown design. In this way, fewer projections can be used, while still providing one for every full cell at each end of the stent.

074] The projections may vary in length, especially depending on the form of interface or mating portion they carry or form. The projections advantageously have a length that allow for efficiently transitioning or transferring the twisting load to the stent while occupying minimal space. Though not necessarily excluded from the invention, projections longer than about one cell's length may have a tendency either warp or twist about the delivery device body in attempted use. This feature can introduce undesirable sizing effects and/or difficulty in handling.

075] Turning to Fig. 5, the mating portions 208, 210 of stent 82 have a shape that nests within seats 162, 164 of the system 100. The projections 212 may comprise shapes including, but not limited to an "L" shape, "T" shape, "V" shape, circular, rectangular, square, polygonal, diamond, triangular, elongate, and slotted projections 212 as the mating portions. In essence, the projections may take any number of shapes so long as they retain the stent in its twist-down state upon the delivery system. Furthermore, the projections 212 on a single stent 82 are not required to be the same shape. Instead, the shapes of the projections 212 may vary from each side of the stent. Furthermore a projection may have a distinct shape from an adjacent projection.

076] In any case, there will be at least a sufficient number of projections 212 extending from each end of the prosthesis 82 to balance the force required to maintain the prosthesis 82 in a reduced diameter upon twisting. For smaller designs (i.e., delivery systems with 0.014 to 0.016 inch crossing profiles) in certain systems, as few as two mating features may be provided on each side of the implant. With an increased compressed size, space is made available for more projections/mating features.

077] The stent 82 may be secured on the delivery system by twisting (or at least partially twisting) the stent 82 prior to loading on the delivery system. Alternatively, the expanded stent 82 may be placed over a delivery system core member, and the ends of the stent 82 then twisted to constrict the stent 82 about the delivery system. Further, appropriate fixturing or preloading into a sleeve or multiple sleeve portions that may be twisted relative to one another may assist in loading of the stent about the delivery system as described in U.S. Patent Application Serial No. 11/265,999, entitled "Indirect-Release Implant Delivery Systems," incorporated by reference for this purpose. Naturally, the approach described there may be

PCT/US2006/034311

modified to accommodate differences between the system referenced therein and those of the present invention.

078] As for a general overview of the subject delivery systems as provided in Fig. 5, delivery system 100 is shown with a stent carried at a distal end 102 of an elongate body in a collapsed configuration. In this example the twisted stent is overlaid by a full-length sheath 104. With the stent in a twisted configuration, at least initial motion of the sheath is eased. In other words, because the stent is held in an at least a partially compressed configuration by the twist imparted thereto, the stent does not push or strain against the sheath to the same degree (or at all), thereby reducing friction at the interface. Thus, the overlaying sheath may be removed (or at least the initial movement of the sheath) more easily relative to a simple-sheath type delivery system. For examples in which the key/seat portions are rotatably manipulatable relative to one another (for example by a handle knob and as in other examples elaborated below) to hold the stent in a collapsed configuration, the sheath may be fully withdrawn from the at least partially twisted stent. As compared to a sheathless-twistdown as provided below, an additional safety margin may be offered by the overlying sheath.

079] As elaborated upon below, alternative stent hold-down features or means may be provided in accordance with the present invention. Regardless, the delivery guide preferably includes/comprises a flexible atraumatic distal tip 108 of one variety or another.

080] On the other end of the delivery device, a handle 110 may be provided. A body 112 of the handle may include one or more of a lever or slider 114 or other means (such as a trigger, knob or wheel) for actuating optional sheath/restraint or core member withdrawal. The delivery device handle may include a lock 116 to prevent inadvertent actuation. Similarly, handle 110 may include various safety or stop features and/or ratchet or clutch mechanisms to ensure one-way actuation. The handle 110 further includes a knob 124 that permits twisting/untwisting of the stent. Of course, other alternative interface means may be provided to effect such action.

081] Furthermore, a removable interface member 118 may be provided to facilitate taking the handle off of the delivery system proximal end 120. The interface may be lockable with respect to the body and preferably includes internal features for disengaging the handle from the delivery guide. Once accomplished, it will be possible to attach or "dock" a secondary length of wire 122 on the delivery system proximal end, allowing the combination to serve as an "exchange length" guidewire, thereby facilitating changing-out the balloon catheter or performing another procedure. Alternatively, a core member within the system may be an exchange-length wire.

082] Fig. 5 also shows packaging 150 containing at least one coiled-up delivery system 100. Packaging may include one or more of an outer box 152 and one or more inner trays

PCT/US2006/034311

154, 156 with peel-away coverings as is customary in medical device product packaging. Naturally, instructions for use 158 may also be provided. Such instructions may be printed product included within packaging 150 or be provided in connection with another readable (including computer-readable) medium. The instructions may include provision for basic operation of the subject devices and associated methodology.

- 083] In support of such use, it is to be understood that various radiopaque markers or features may be employed in the system to 1) locate stent position and length, 2) indicate device actuation and stent delivery and/or 3) locate the distal end of the delivery guide. As such, various platinum (or other radiopaque material) bands or other markers (such as tantalum plugs) may be incorporated into the system. Especially where the stent employed may shorten somewhat upon deployment, it may also be desired to align radiopaque features with the expected location (relative to the body of the guide member) of the stent upon deployment. For such purposes, radiopaque features may be set upon the core member of the delivery device proximal and distal of the stent.
- 084] While Fig. 5 illustrates a full-size delivery system, a number of the following figures illustrate detail views of the far or distal end 102 of such a system 100, that depict a number of approaches for releasably securing a stent for delivery according to the present invention. The device features are typically incorporated into complete systems and may be used in the manner described, as well as others as may be apparent to those with skill in the art.
- 085] Accordingly, Fig. 6 illustrates the far end 102 of a delivery system end including a prosthesis (e.g., a stent) 82 placed about an inner member underlying the stent. As referenced above, prosthesis 82 comprises a proximal/near end 202, a distal/far end 204 and a support structure 206 extending therebetween. As noted above, support structure 206 comprises a mesh, lattice, woven, or other similar structure that reduces in diameter upon rotation of near end 202 relative to far end 204. Such a structure offers excellent strength and uniform support when expanded, yet does not foreshorten to the degree that a coil stent does in expansion from a compressed configuration.
- 086] Prosthesis 82 further comprises projections that permit retention of the prosthesis 82 on delivery system 100 when the ends are rotated relative to one another. The projections shown comprise a near key, interface or mating portion 208 and a far key, interface or mating portion 210. The various structures described for the seats and mating portions that interface or compliment one another to retain the stent to the elongate member may be regarded as the various means for retaining the prosthesis to the elongate member disclosed herein. An exemplary representation of the stent-side mating/interface features is presented in Figs. 8A-8D.

~~PCT/US06/34311~~

087] Complimentary seats are shown in the various delivery guide portions. For example, In Figs. 6 and 7 respective seats 162, 164 of system 100 receive hook or L-shaped mating portions 208 and 210 of the type shown in Fig. 8A.

088] Fig. 7 depicts the variation of the system 100 shown in Fig. 6 without the prosthesis so as to better illustrate the various elements. As illustrated, an inner member 170 extends through at least a portion of the system 100. It should be noted that the inner member 170 may comprise a coiled guide wire, a core wire, or other member that extends through the entire system 100 or at least a portion of the system. The distal end of the core member 170 comprises the distal end of the system 100 and may include a coil tip 172 or other atraumatic tip for navigation through delicate body structures (e.g., the peripheral vasculature, or other vasculature, ducts passageways, etc.). The core member 170 includes a section for mounting the prosthesis which may be tapered from a remainder of the core member. In addition, to accommodate a coil tip 172, the core member 170 may include one or more additional tapered segments that permit tuning system flexibility and/or construction of a compliant coil tip 172.

089] Fig. 7 also shows the far seat 164 associated with the core member 170. The seat comprises a geometry 168 shaped to receive the far mating portion of the prosthesis. The far seat 164 may be integral with the core member 170 or may be affixed to the core member.

090] The near seat 162 includes a receptacle form 166 that is shaped to receive the near mating portion of the prosthesis. As illustrated, the near seat 162 is formed from the distal end of an outer member 174 that extends over at least a portion of the core member 170. In this variation, the core member 170 may be moveable relative to the outer member 174. In one variation, the core member 170 may be rotatable relative to the outer member 174. Alternatively, or additionally, the core member 170 and the outer member 174 may be axially moveable relative to each other. Such features are useful to retain and/or deploy the prosthesis as discussed below.

091] The core member 170 may be elongate and have a comparatively small effective diameter. It has the function of permitting delivery of the prosthesis to a selected site and supporting the prosthesis in a collapsed form during positioning and implantation. The core member may be solid, or may have a lumen extending therethrough, depending on such factors as the degree of flexibility required, the type of associated release mechanism, the constituent material, and the like. The tip of the core member (i.e., the distal end of the delivery system) may include an atraumatic tip and be tapered and/or straight, curved, or J-shaped, depending on factors such as physician preference the anatomy of the tubular organ or region of interest, degree of stiffness required, and the like.

~~PCT/US06/34311~~

0092] As noted herein, the subject delivery system 100 employs a prosthesis 82 that reduces in diameter when the ends of the prosthesis are rotated relative to each other in a first direction. Accordingly, when the mating portions 208, 210 of the prosthesis are nested with the near and far seats 162, 164, the near and far ends 202, 204 of the prosthesis 82 are restrained or prevented from rotating in a second direction to expand the prosthesis until desired by the medical practitioner. To assist in restraining the prosthesis, the core member 170 may be releasably locked relative to the outer member 174 to prevent relative movement. Therefore, when desired, the core member 170 and outer member 174 may be released so that the prosthesis may untwist to expand in diameter (e.g., where the prosthesis self expands). In some variations of the invention, the medical practitioner may assist in expanding the prosthesis by rotating the core member 170 relative to the outer member 174.

0093] The ability to axially move the outer member 174 relative to the core member 170 may assist in restraining or assist in deploying the prosthesis. For example, variations of the invention described herein may rely upon moving the far seat 164 distally relative to the near seat 162 to disengage the projections of the prosthesis from the seats. Alternatively, when the projections are hook or L-shaped, movement of the far seat 164 distally relative to the near seat 162 causes axial "extension" of the prosthesis which counteracts any internal bias within the prosthesis to expand. It should be noted that movement of the seats may be accomplished in any number of ways. For example, the core member may advance relative to the near seat. Alternatively, the near seat (or outer member) may be withdrawn relative to the distal seat.

0094] As mentioned above, the near and far seats 162, 164 each define a receptacle form 166, 168 shaped to receive the mating portions 208, 210 of the prosthesis. The receptacle geometries may comprise a plurality of openings (as illustrated) shaped to receive one or more projection(s) of the prosthesis. The openings may extend partially to a certain depth (i.e., forming a pocket). Alternatively, the openings may extend through the entire member. As noted above with respect to the projections, the shapes of the openings may include, but are not limited to: "L" shapes, "T" shapes, "V" shapes, circular, rectangular, square, polygonal, diamond, triangular, and slot shapes.

0095] Figs. 8A-8F, illustrates variations of projections 212 for use in the present invention. As illustrated Fig. 8A shows an "L" shaped projection. Fig. 8B illustrates a rectangular shaped projection 212. It is noted that Fig. 8B also illustrates the projection 212 as having optional notches 214. Such features can assist by offering additional compliance in compressing the adjacent struts 52 of the stent through material removal at their junction with the projection. Fig. 8C illustrates a "T" shaped projection 212. Figs. 8D and 8E illustrates circular shaped projections and "V" shaped projections respectively. Fig. 8D also illustrates an example of

PCT/US2006/34311

radiopaque marker 216 (e.g., a tantalum plug). The projections may align with the struts/cell geometry, or they may be offset therefrom. By offsetting the entire projection and/or portion(s) thereof (e.g., as in the Fig. 8A variation) the features may be situated to more advantageously counteract any tendency of the ends of the stent or the projections themselves to lift off the delivery guide body components due to the twisting imparted to the same.

096] Alternatively, region 216 may be left open in order to provide a mating portion defined by negative space. In such fashion, the mating portion of the projection comprises the receptacle for receiving a pin or another member (the seating interface on the delivery system). A similar approach is shown in Fig. 8F, but negative space 216 is provided as a portion of the stent cell geometry in a "C" shaped form. Irregardless of construction, various male or female interface approaches may be employed. Indeed, the mating portions formed on or by the projections may have any number of different shapes so long as they are conducive to interfacing with complimentary delivery system hardware.

097] In addition, a single prosthesis or stent may have any number of projections of various shapes so long as the projections do not unacceptably interfere or contact on another when compressing the stent. Accordingly, it is understood that the shape and configuration of the projection may vary for any number of factors (e.g., the particular application, the size of the stent, the tortuosity of the vasculature, etc.). As a result, the projections may comprise any hook, prong, opening, socket, key, grasper, tooth, bar or slot shaped configuration (whether the shape is nearly planar or significantly extends in three dimensions) in addition to those shapes discussed herein. In accordance with the above, it follows that the corresponding seating features will be selected to accommodate the shape of the respective projection.

098] In any case, the shapes of the projections will be selected so as not to create undue risk of injury to the patient. For example, for vascular applications, the shape of the projections must be chosen so as not to create undue trauma to the vessel wall. On the other hand, non-vascular applications may not present the same risks. Accordingly, the design of the projections may be more aggressive in stents intended for such applications.

099] As discussed above, the invention contemplates the use of one or more sleeves completely covering the implant as shown in Fig. 5, or set about the near and/or far end of the stent to assist in retention of the stent about the system. Alternative variations of the delivery system 100 may employ the stent without any additional sleeves or restraints as shown in Fig. 6 and others below, including the variation shown in Fig. 9A.

100] In Fig. 9A, delivery system end 102 employs elongate projections 212 nested in the near and far seats 162, 164 that have "slot-shaped" openings 166, 168 to accommodate the elongate projections. The prosthesis or stent 82 may be deployed by rotating the far seat 164 relative to the near seat 162 to untwist the stent 82, allowing the projections 212 to slide or

PCT/US2006/034311

release (radially outward) from the seats. Alternatively, or in combination, the near and far seats 162, 164 may be moved away from each other to free a self-expanding stent 82 from restraint. In such a case, the stent 82, once removed from the restraints, untwists to expand.

0101] Fig. 9B illustrates the system interface approach taught in Fig. 9A with the addition of at least one of a near and far (or first and second) sleeves or bands 176, 178. It should be noted that for clarity the sleeves are drawn as being clear. However, the sleeves may be clear, opaque, radiolucent, or otherwise visible. The sleeves may be desired in order to provide an additional level of safety from inadvertent release of the stent. The sleeves insure that projections 210 cannot lift out of their respective seats (e.g., in extreme tortuosity). Rather, the stent can only be released upon untwisting of the stent (causing foreshortening and pull-out) or by user separation of the seats by manipulation of delivery system 100.

0102] The release may occur simultaneously between the ends, or it may be staged. To stage the release when using elongate members that pull out of their respective seats, the length of the projections may vary from one side of the implant to the other. Assuming an equal rate of withdrawal, this can cause the shorter one(s) to withdraw relatively sooner, leaving at least a portion of the longer members engaged. Alternatively, the longer one(s) may remain stationary due to higher static friction than the shorter one(s), while the shorter members are first withdrawn. In either case, the remaining side of the implant may be released by manipulating the position of the delivery system (e.g., moving it proximally to release a proximal side or distally to release a distal side). Alternatively, expansion of the stent from the first side released can cause foreshortening and/or an angle change at the second end of the stent causing it to self-deploy in sequential fashion. In yet another approach in support of sequential end release, the projections may differ in shape from one side to the other such that one side is retained by an interlocking interface while the other is withdrawn. Such systems are discussed further below.

0103] Fig. 9C illustrates another variation optionally employing a substantially different mode of implant release. In this variation, the system end 102 comprises near and far seats 162, 164 having near and far openings 166, 168 that each have "L" shaped openings. The stent 82 comprises corresponding "L" shaped projections. To deploy the stent 82, the near and far seats 162, 164 are rotated relative to one another causing the stent 82 to expand at its center. This action may cause the mating portions to lift out of their nesting regions. Alternatively, once the center of the stent 82 expands by untwisting alone, the practitioner may move the seats together to force the projections to lift out of the seats and deform cap or sleeve portions 176, 178.

0104] Accordingly, the sleeves or caps in the variation show in Fig. 9C must be flexible enough or friable/splittable to allow the mating portions to lift out. Stated otherwise, the

PCT/US2006/034311

sleeves 176, 178 will be adapted to allow the projections to leave the openings. As the stent foreshortens, the projections will typically retract past the sleeve portions 176, 178. In contrast, note that the sleeves or caps 176, 178 in the variation of the invention in Fig. 9B may be either flexible or rigid since their deformation is not required to release the mating portions which are not initially axially locked.

0105] Fig. 10A illustrates a variation of a delivery system according to the present invention with an end 102 adapted to employ a stent 82 with projections having different configurations on either end of its body. In the illustrated example, the near and far seats 162, 164 seat a stent 82 having projections 212 at a far end 204 that are elongate and projections 212 at a near end 202 that are hooked (having a hook portion extending out-of-plane) or "L" shaped. Stent deployment in this variation of the invention occurs as discussed above via axial movement of the far seat 164 (or core member) away from the near seat 162 to disengage the projections 212 at the far end 204 of the stent while those at the near end 202 remain engaged with the near seat 162. Then, once released from the state of tension/torsion, the near keys/engagement members release from the seats. Though expansion of the stent may occur nearly instantaneously, it still results in a distal-to-proximal deployment as is generally desired.

0106] Fig. 10B illustrates a system having an end 102 similar to that of Fig. 10A, with the addition of a sleeve 180 that is slidable over a portion of the system 100. In this variation, the system also includes a far sleeve or cap 178. However, it is contemplated that the sleeve 180 may be extendable over the entire length of the stent 82 to serve as a sheath without the use of such a sleeve or cap as in a system described above in connection with Fig. 5. The sheath may comprise a flexible polymeric material or be otherwise constructed.

0107] With the device shown in Fig. 10B, deployment occurs by moving the proximal seat (together with sleeve 180) relative to the distal seat 164 to first release the slidable projections 212 from far seat 164. At this point, the stent unwinds and expands. Then, sleeve or sheath 180 is withdrawn to release the projections from proximal seat 162. (In this instance, at least the distal end of sleeve is such that it can hold the keyed features without their automatic release as in the variation of the invention in Fig. 9C.) In such a configuration, sleeve or sheath 180 offers a remotely actuatable "saftey" ensuring so that the stent is prevented from deploying until desired by the medical practitioner.

0108] Fig. 11A shows a detail view of the system 100 approach described in connection with Fig. 5 in which a stent 82 may be twisted to the reduced diameter configuration and covered with a sleeve 180 that is slidable over the stent at a distal end 102 of the system. With one or more sleeve portions covering a majority or substantially all of the stent, the stent need not be twisted down to the degree required for full compression without the sleeve.



- 00109] Each of Figs. 11B and 11C illustrate approaches resembling those in Figs. 10B and 9C, respectively. They differ primarily in that the Fig. 11B and 11C variations include a longer sleeve 180 that is relied upon, in part to maintain the compressed diameter of the stent. As shown in these figures, when sleeve 180 is withdrawn, stent 82 bulges outward. Such an approach may be employed to accomplish stent release without the need for any rotational manipulation of the delivery guide. Rather, by foreshortening the stent out of the far seats, the far side of the stent is able to self-release upon withdrawing sleeve 180.
- 00110] In the alternative, delivery systems as shown in Figs. 11A-11C may be employed more like simple-sheath systems. That is to say, twist imparted upon the stent may be imparted directly preceding insertion in the body or before sheath 180 withdrawal. In this manner, the twist imparted to the body may help break any stiction (static friction) and/or reduces the stent-induced-friction against the sleeve 180 by virtue of the twist to the stent body reducing the outward force the stent imparts on the sleeve. As such, the practitioner may then remove the sleeve 180 using less force.
- 00111] In any case, Figure 11B illustrates a variation in which an additional sleeve 178 is located over the far end of the stent 82 and where the far seat 164 allows for self-release of the stent 82. As the sleeve 180 withdraws from the stent 82, the stent 82 bulges or expands causing it to foreshorten and self-release from the far seat 164. It should be noted that the near end of the stent 82 may be designed to release the stent 82 upon removal of the sleeve 180. Alternatively, the near end of the stent 82 may release after the remainder of the stent 82 expands to a certain-size that causes the near end to pull out of the near seat 166.
- 00112] Figure 11C illustrates a variation similar to that of Figs. 11A and 11B in that the additional sleeve 178 is located over the stent 82. In this variation, the system includes an additional deformable sleeve 178. As the sleeve 180 withdraws from over the far end of the stent 82, the stent 82 bulges causing the deformable sleeve 178 to deform. This action allows the far end of the stent 82 to release from the far seats 164. As noted above, the near end of the stent 82 may be designed to release the stent 82 either upon removal of the sleeve 180. Alternatively, the near end of the stent 82 may release after the remainder of the stent 82 expands to a certain size that causes the near end to pull out of the near seat 166.
- 00113] Fig. 11D illustrates a variation of a sleeve 180 for use with the systems such as described in Figs. 11A-C. As shown, the sleeve 180 may be fabricated to include one or more wires or filaments 182 within or just beneath the sleeve wall. In practice, the medical practitioner pulls the wire/filament causing a tear in the sheath that allows (or causes) the stent to expand. In an alternative construction, the tear-wire 182 may be a suture strand or another filament that underlies the body and wraps around as shown. Fig. 11E illustrates another variation of a sleeve 180 including an everting portion 184 that folds upon itself.

PCT/US2006/034311

When subjected to the expansion force applied by the stent as it expands, the member may roll back. Such a construction may offer an alternative in instances above where a flexible sleeve 184 was called-out.

- 00114] In another mode of operation, the everting portion 184 may evert when the sleeve 180 is withdrawn. As shown, the everting portion may comprise a plurality of separate members. Alternatively, sleeve 180 may be whole such that the outer sleeve portion and the everting portion roll past one another. Still further, it is contemplated that (especially for small-diameter delivery systems) that the everting portion tears open into individual segments as the near end of sleeve 180 is withdrawn. The material may be pre-scored or notched to facilitate such action as may be desirable for lowering forces or accommodating substantially inelastic material rolling from a smaller diameter to a relatively larger diameter.
- 00115] Addition delivery system designs are shown in Figs. 12A-14B. As in the other systems described herein, these delivery systems hold a radially-expandable prosthesis (such as a stent) in a collapsed configuration for delivery (at least in part) by winding-up or twisting the stent in a compressed profile. In certain of these examples, the stents include projections that nest within seats of the delivery system. In those variations in which the implant body does not include such projections, the delivery seats are adapted to interface directly with the stent.
- 00116] Figs 12A and 12B show a first variation of these devices in which projections from the stent may or may not be employed. As with the other variations of the invention above, delivery guide 182 preferably includes an atraumatic tip 1202. A body or shaft 1204 of the device in the form of a tube or sleeve includes hooks 1206 at a distal end. The body is advantageously made of hypotubing in order to manufacture the hooks integral thereto.
- 00117] Near and far mating portions of the stent may be provided in openings within the cell structure or recesses formed within stent projections (see, e.g., Figs. 8D and 8E) that accommodate the near and far seats of the delivery guide 1800. In this variation, the near seats comprise complementary seating hooks 1206' that are formed from the hypotubing. The hooks 1206' are distal to the hypotubing and supported by a core member 1208. Hooks 1206' may be formed in connection with a ring 1210 or be provided otherwise. In any case, the hooks (typically numbering at least two per side to balance forces) are dimensioned with a prong 1212 and recess 1214 suited for receipt of a stent. Together a complementary set of hooks 1206/1206' comprise the near and far seats that receive a stent and stretch it to hold it in a collapsed form when stretched or extended axially and twisted as shown in Fig. 12B. Alternatively, a twisting mode of stent compression or retention may alone be employed. Still, it has been appreciated that in certain loading schemes that a hook type interface (as shown in Fig. 12A and 12B or as in Figs. 6 and 7) can be very helpful.

~~PCT/US06/34311~~

- 00118] Regardless, in the configuration shown where the hooks have no overhang (so as to facilitate stent release), the system relies on friction between the stent and hooks to hold the stent in place when the stent is axially stretched. Still, interference features between the stent and hooks may be provided to facilitate hold-down. Whatever the case, stent release is accomplished by releasing the tension and/or torque holding the stent in its collapsed profile.
- 00119] In the variation of the invention shown in Fig. 13A and 13B, a delivery guide 1300 is provided that, again, preferably includes an atraumatic tip 1302. Furthermore, a body or shaft 1304 (advantageously, hypotubing) and a core wire member 1308 are provided. However, in the variation shown in Figs. 13A and 13B, rather than providing radially-oriented hooks as seats, the near and far seats comprise radially oriented thread-like graspers 1306 and 1306'. At a proximal side of the device, they are shown integral with the hypotube. At a distal end, they are shown fabricated in connection with a ring 1310.
- 00120] As shown in Fig. 13B, the graspers (ranging in number from at least one per side to very many) act like teeth capture a complimentary shaped stent 1312 having mating portions or keys 1314 sized to fit within grasper slots 1316. By virtue of their complimentary angular component along which the stent projections and delivery guide components interface, these members are intended to "bite" like a threaded interface in order to reinforce their association. Otherwise, the current system differs little from that shown in Figs. 6 and 7, relying on flag or flat hook-shaped members.
- 00121] As in other one of the subject delivery systems, the stent is collapsed or at least held in collapsed state for delivery by imparting a torque to the system. In addition, the stent may be placed under tension as indicated – pushing the core wire forward relative to the hypotube (or vice versa). Naturally, release will be effected upon removal of the wind-up and/or pull-down forces. In which case, the stent will be able to expand and free its keys 1314 from slots 1314 by way of radial expansion.
- 00122] The final example of twist-based stent hold down provided herein is illustrated in Figs. 14A and 14B. Fig. 14B shows a detail view of a delivery guide device seat in the form of a chuck-type 1400 feature comprising a body 1402 and a plurality of extensions 1404 therefrom. The body may be provided by hypotubing or a separate member. In any case, seat 1400 is shown riding over a core wire 1406 of a delivery device as with the hook or grasper features in the preceding variations of the invention.
- 00123] The number of extension for the seat will depend on the stent 1408 with which the member is designed to interface. As shown in Fig. 14B, a four-extension chuck interface mates neatly with a stent having end portions that include four strut ends 1410. When closely-packed as shown, counter-rotation of complementary pairs of seats/chucks 1400 will capture the stent. Thus captured, the stent may be held down to a core member for delivery by this

PCT/US2006/034311

mode alone. In the alternative, some measure of tension, an overlaying sheath, or band, etc. may be applied thereto. Whatever the hold-down mode desired, it can be appreciated that the system of Figs. 14A and 14B represents a sort of "self-locking" system, just as other ones of those described above.

0124] In more general terms, the invention includes methods that may be performed using the subject devices or by other means. The methods may all comprise the act of providing a suitable device. Such provision may be performed by the end user. In other words, the "providing" (e.g., a delivery system) merely requires the end user obtain, access, approach, position, set-up, activate, power-up or otherwise act to provide the requisite device in the subject method. Methods recited herein may be carried out in any order of the recited events which is logically possible, as well as in the recited order of events.

0125] Exemplary aspects of the invention, together with details regarding material selection and manufacture have been set forth above. As for other details of the present invention, these may be appreciated in connection with the above-referenced patents and publications as well as generally known or appreciated by those with skill in the art. For example, one with skill in the art will appreciate that a lubricious coating (e.g., hydrophilic polymers such as polyvinylpyrrolidone-based compositions, fluoropolymers such as tetrafluoroethylene, hydrophilic gel or silicones) may be placed on the core member of the device, if desired to facilitate low friction manipulation. The same may hold true with respect to method-based aspects of the invention in terms of additional acts as commonly or logically employed.

0126] In addition, though the invention has been described in reference to several examples, optionally incorporating various features, the invention is not to be limited to that which is described or indicated as contemplated with respect to each variation of the invention. Various changes may be made to the invention described and equivalents (whether recited herein or not included for the sake of some brevity) may be substituted without departing from the true spirit and scope of the invention. In addition, where a range of values is provided, it is understood that every intervening value, between the upper and lower limit of that range and any other stated or intervening value in that stated range is encompassed within the invention.

0127] Also, it is contemplated that any optional feature of the inventive variations described may be set forth and claimed independently, or in combination with any one or more of the features described herein. Reference to a singular item, includes the possibility that there are plural of the same items present. More specifically, as used herein and in the appended claims, the singular forms "a," "an," "said," and "the" include plural referents unless the specifically stated otherwise. In other words, use of the articles allow for "at least one" of the subject item in the description above as well as the claims below. It is further noted that the claims may be drafted to exclude any optional element. As such, this statement is intended to

PCT/US2006/034311

serve as antecedent basis for use of such exclusive terminology as “solely,” “only” and the like in connection with the recitation of claim elements, or use of a “negative” limitation.

0128] Without the use of such exclusive terminology, the term “comprising” in the claims shall allow for the inclusion of any additional element – irrespective of whether a given number of elements are enumerated in the claim, or the addition of a feature could be regarded as transforming the nature of an element set forth in the claims. Except as specifically defined herein, all technical and scientific terms used herein are to be given as broad a commonly understood meaning as possible while maintaining claim validity.

0129] The breadth of the present invention is not to be limited to the examples provided and/or the subject specification, but rather only by the scope of the claim language. That being said, we claim:

~~PCT/US2006/034311~~

1. A system for treating a body organ, the system comprising:
  - an elongate member having a distal portion;
  - a prosthesis comprising a near end, a far end and a structure extending therebetween, where the structure comprises a mesh, lattice, or woven structure that is able to reduce in diameter upon rotation of the near end relative to the far end, the prosthesis further comprising a near mating portion and a far mating portion, where the near and far ends are rotated relative to one another in a first direction to reduce a diameter of the prosthesis to mount the prosthesis to the distal portion of the elongate member; and
  - a near seat receiving the near mating portion of the prosthesis and a far seat receiving the far mating portion of the prosthesis, wherein when the mating portions are nested with the near and far seats, the near and far ends of the prosthesis are restrained from rotating in a second direction to expand the prosthesis.
2. The deliver system of claim 1, wherein the near seat and near mating portion comprise a near retaining means for retaining the near end of the prosthesis to the elongate member, and wherein the far seat and far mating portion comprise a far retaining means for retaining the far end of the prosthesis to the elongate member.
3. The deliver system of claim 1, wherein the near and far seats each comprise a respective geometry shaped to receive the near and far mating portions respectively.
4. The delivery system of claim 3, wherein the near mating portion of the prosthesis comprises a plurality of near projections and the far mating portion of the prosthesis comprises a plurality of far projections where each projection extends from the near and far ends of the prosthesis respectively, and wherein the near seat geometry comprises a plurality of openings shaped to receive at least one of the near projections and wherein the far seat geometry comprises a plurality of openings shaped to receive at least one of the far projections.
5. The delivery system of claim 4, where each of the plurality of near seat openings comprises an elongate opening.
6. The delivery system of claim 4, where the plurality of near seat openings comprises a plurality of pockets.
7. The delivery system of claim 4, where each of the plurality of far seat openings comprises an elongate opening.

PCT/US2006/034311

8. The delivery system of claim 4, where the plurality of far seat openings comprises a plurality of pockets.
9. The delivery system of claim 3, where the near seat geometry is selected from "L" shape, "T" shape, "V" shape, "C" shape, circular, rectangular, square, polygonal, triangular and elongate forms.
10. The delivery system of claim 3, where the far seat geometry is selected from "L" shape, "T" shape, "V" shape, "C" shape, circular, rectangular, square, polygonal, triangular and elongate forms.
11. The delivery system of claim 3, where the near mating portion comprises a plurality of hook shaped members.
12. The delivery system of claim 11, where the near seat geometry comprises an opening shaped to receive a portion of the hook shaped member.
13. The delivery system of claim 3, where the far mating portion comprises a plurality of hook shaped members.
14. The delivery system of claim 13, where the near seat geometry comprises an opening shaped to receive a portion of a hook shaped member.
15. The delivery system of claim 1, where the near seat and far seat are attached to the elongate member.
16. The delivery system of claim 15, where the elongate member further comprises an inner member and an outer member having a distal end.
17. The delivery system of claim 16, where the inner member extends through at least a portion of the outer member and out through the distal end of the outer member, and where the inner member is moveable relative to the distal end of the outer member.
18. The delivery system of claim 17, where the outer member comprises a radiopaque marker.
19. The delivery system of claim 17, where outer member includes the near seat and the inner member includes the far seat.

PCT/US2006/034311

20. The delivery system of claim 17, where the inner member and outer member are axially moveable relative to one another.
21. The delivery system of claim 17, where the inner member and outer member are rotatable relative to one another.
22. The delivery system of claim 21, where the near seat and far seat are releasably lockable to control rotation of the near seat relative to the far seat.
23. The delivery system of claim 17, where the prosthesis is mounted about a distal portion of the inner member and adjacent to the distal end of the outer member.
24. The delivery system of claim 16, where the outer member is slidably located over at least the near seat.
25. The delivery system of claim 16, where the outer member further comprises a wire or filament located in a wall of the outer member, such that when pulled, the wire or filament tears the outer member.
26. The delivery system of claim 16, where the outer member further comprises an end portion configured to evert.
27. The delivery system of claim 1, where the prosthesis comprises a stent.
28. The delivery system of claim 27, where an Af temperature of the stent is set for a shape memory.
29. The delivery system of claim 28, where the Af temperature of the stent is set for super-elasticity.
30. The delivery system of claim 27, where the stent is a self-expanding stent.
31. The delivery system of claim 27, where the stent further comprises a therapeutic agent.
32. The delivery system of claim 27, where the stent further comprises a radiopaque marker.
33. The delivery system of claim 1, where the elongate member further comprises a radiopaque marker.



PCT/US2006/034311

34. The delivery system of claim 1, further comprising a first sleeve located over at least the near seat.
35. The delivery system of claim 34, where the first sleeve is flexible.
36. The delivery system of claim 1, further comprising a second sleeve located over at least the far seat.
37. The delivery system of claim 36, where the second sleeve is flexible.
38. A delivery system for treating a body organ, the system comprising:  
an elongate member having a distal portion and an outer member;  
a prosthesis comprising a near end, a far end and a structure extending therebetween, where the structure comprises a mesh, lattice, or woven structure that is able to reduce in diameter upon rotation of the near end relative to the far end, the prosthesis further comprising a near mating portion and a far mating portion, where the ends are rotated relative to one another in a first direction to reduce a diameter of the prosthesis to mount the prosthesis to the distal portion of the elongate member;  
a near seat receiving the near mating portion of the prosthesis and a far seat receiving the far mating portion of the prosthesis, where when the mating portions are nested with the near and far seats, the near and far ends of the prosthesis are restrained from rotating in a second direction to expand the prosthesis; and  
the outer member located over at least the near seat.
39. The deliver system of claim 38, where near seat and near mating portion comprises a near retaining means for retaining the near end of the prosthesis to the elongate member, and where the far seat and far mating portion comprises a far retaining means for retaining the far end of the prosthesis to the elongate member.
40. The deliver system of claim 38, where the near seat and far seat each comprise a respective geometry shaped to receive the near and far mating portions respectively.
41. The delivery system of claim 40, where the near mating portion of the prosthesis comprises a plurality of near projections and the far mating portion of the prosthesis comprises a plurality of far projections where each projection extends from the near and far ends of the prosthesis respectively, and where the near seat geometry comprises a plurality of openings shaped to receive at least one of the

PCT/US2006/034311

near projections and where the far seat geometry comprises a plurality of openings shaped to receive at least one of the far projections.

42. The delivery system of claim 41, where the plurality of near seat openings comprises elongate opening.
43. The delivery system of claim 41, where the plurality of near seat openings comprises a plurality of pockets.
44. The delivery system of claim 41, where the plurality of far seat openings comprises elongate opening.
45. The delivery system of claim 41, where the plurality of far seat openings comprises a plurality of pockets.
46. The delivery system of claim 41, where the near seat geometry comprises a shape selected from the following: "L" shape, "T" shape, "V" shape, circular, rectangular, square, polygonal, diamond, triangular, elongate, and slot shaped.
47. The delivery system of claim 41, where the far seat geometry comprises a shape selected from the following: "L" shape, "T" shape, "V" shape, circular, rectangular, square, polygonal, diamond, triangular, elongate, and slot shaped.
48. The delivery system of claim 40, where the near mating portion comprises a plurality of hook shaped members.
49. The delivery system of claim 40, where the near seat geometry comprises an opening shaped to receive a portion of the hook shaped member.
50. The delivery system of claim 40, where the far mating portion comprises a plurality of hook shaped members.
51. The delivery system of claim 50, where the near seat geometry comprises an opening shaped to receive a portion of the hook shaped member.
52. The delivery system of claim 40, where the near seat and far seat are attached to the elongate member.
53. The delivery system of claim 38, where the elongate member further comprises an inner member, where the inner member extends through at least a

PCT/US06/34311

portion of the outer member and out through the distal end of the outer member, and where the inner member is moveable relative to the distal end of the outer member.

54. The delivery system of claim 53, where the outer member is slidable over at least a portion of the inner member.
55. The delivery system of claim 54, where the outer member is slidable over the prosthesis.
56. The delivery system of claim 53, where the outer member comprises a radiopaque marker.
57. The delivery system of claim 53, where outer member includes the near seat and the inner member includes the far seat.
58. The delivery system of claim 53, where the inner member and outer member are axially moveable relative to one another.
59. The delivery system of claim 53, where the inner member and outer member are rotatable relative to one another.
60. The delivery system of claim 53, where the outer member further comprises a wire or filament located in a wall of the outer member, such that when pulled, the wire or filament tears the sheath.
61. The delivery system of claim 53, where the outer member further comprises an end portion configured to evert.
62. The delivery system of claim 59, where the near seat and far seat are releasably lockable to control rotation of the near seat relative to the far seat.
63. The delivery system of claim 59, where the prosthesis is mounted about the distal portion of the inner member and adjacent to the distal end of the outer member.
64. The delivery system of claim 38, where the prosthesis comprises a stent.
65. The delivery system of claim 64, where the stent comprises a shape memory alloy.

PCT/US2006/034311

66. The delivery system of claim 65, where the shape memory alloy comprises a super-elastic alloy.
67. The delivery system of claim 64, where the stent is a self-expanding stent.
68. The delivery system of claim 64, where the stent further comprises a antiproliferative drug.
69. The delivery system of claim 64, where the stent further comprises a radiopaque marker.
70. The delivery system of claim 38, where the elongate member further comprises a radiopaque marker.
71. The delivery system of claim 38, further comprising a second sleeve located over at least the far seat.
72. The delivery system of claim 71, where the second sleeve is flexible.
73. A medical device prosthesis for use with a twist-down delivery system, the prosthesis comprising:  
a near end, a far end and a support structure extending therebetween, where the structure comprises a mesh or woven structure that is able to reduce in diameter upon rotation of the near end relative to the far end;  
a near mating portion comprising a plurality of near projections; and  
a far mating portion comprising a plurality of far projections, such that when the ends are rotated relative to one another in a first direction to reduce a diameter of the prosthesis and the near and far mating portions are releasably restrained on the delivery system, the structure retains a reduced diameter, and when the near and far mating portions are released from the delivery system, the structure rotates in a second direction to assume an expanded diameter.
74. The prosthesis of claim 73, where one of the plurality of near projections or far projections comprise a shape selected from "L" shape, "T" shape, "V" shape, "C" shape, circular, rectangular, square, polygonal, triangular and elongate forms.
75. The prosthesis of claim 73, where the structure comprises a closed cell structure.

PCT/US2006/034311

76. The prosthesis of claim 73, where the plurality of far projections comprises a plurality of hook shaped members.
77. The prosthesis of claim 73, where the plurality of near projections comprises a plurality of hook shaped members.
78. The prosthesis of claim 73, where the support structure comprises a shape memory alloy.
79. The prosthesis of claim 78, where the shape memory alloy comprises a super-elastic alloy.
80. The prosthesis of claim 73, where the stent is a self-expanding stent.
81. The prosthesis of claim 73, where the stent further comprises a therapeutic agent.
82. The prosthesis of claim 73, where the stent further comprises a radiopaque marker.
83. A method of securing a mesh stent on a delivery guide, the method comprising:  
twisting a first end of the mesh stent relative to a second end of the mesh stent to reduce a diameter of the stent; and  
removably securing a plurality of projections on each end of the stent to a delivery guide.
84. The method of claim 83, further comprising placing a first sleeve over the first end of the mesh stent.
85. The method of claim 83, further comprising a second sleeve over the second end of the mesh stent.
86. The method of claim 83, where removably securing the plurality of projections on each end of the stent comprises axially moving a distal portion of the delivery guide and a proximal portion of the delivery catheter away from each other and placing the mesh stent between each portion to place the mesh stent in a state of compression.

PCT/US06/34311

87. The method of claim 83, where the delivery guide includes a plurality of seats having a geometry to receive the plurality of projections.
88. The method of claim 87, where at least one seat comprise an opening or pocket.
89. The method of claim 87, where the plurality of seats comprises a plurality of near seats and a plurality of far seats.
90. The method of claim 83, further comprising a sheath covering at least a portion of the stent.
91. The method of claim 90, where the sheath includes a wire or filament located in a wall of the sheath, and further comprising pulling the wire or filament to weaken or tear the wall of the sheath to allow the stent to expand.
92. The method of claim 90, further comprising at least partially withdrawing the sheath from the stent to cause a portion of the stent to expand and disengage from the delivery guide.
93. The method of claim 90, further comprising everting a portion of the sheath to permit at least a portion of the stent to disengage from the delivery guide.
94. The method of claim 90, further comprising:  
further reducing the stent in diameter by twisting such that a friction between the stent and sheath decreases, and  
withdrawing the sheath from the stent.
95. The method of claim 83, where at least one of the projections comprises a shape selected from L" shape, "T" shape, "V" shape, circular, rectangular, square, polygonal, diamond, triangular, elongate, hook and slot shape.
96. The method of claim 83, where at least one of the projections comprises a hook-shape.
97. A method of deploying a mesh stent within a body organ where a near end of the mesh stent is rotated in a first direction relative to a far end of the mesh stent, and where the near end and far end include a plurality of projections removably secured to a delivery guide, the method comprising:

~~PCT/US06/34311~~

moving a first portion of the delivery guide relative to a second portion of the delivery guide to release the projections from the delivery guide.

98. The method of claim 97, where moving the first portion of the delivery guide causes the mesh stent to rotate in a second direction.
99. The method of claim 97, where moving the first portion of the delivery guide relative to the second portion of the delivery guide comprises rotating the first portion relative to the second portion in a second direction.
100. The method of claim 97, where moving the first portion of the delivery guide relative to the second portion of the delivery guide comprises moving the first portion of the delivery guide axially away from the second portion of the delivery guide.
101. The method of claim 97, where moving the first portion of the delivery guide relative to the second portion of the delivery guide comprises moving the first portion of the delivery guide axially towards the second portion of the delivery guide.
102. The method of claim 97, where the guide includes a plurality of seats having a geometry to receive the plurality of projections.
103. The method of claim 102, where at least one seat comprise an opening or pocket.
104. The method of claim 102, where the plurality of seats comprises a plurality of near seats and a plurality of far seats.
105. The method of claim 97, further comprising at least one sleeve over a portion of the projections of the stent.
106. The method of claim 97, further comprising a sheath covering at least a portion of the stent.
107. The method of claim 106, where the sheath includes a wire or filament located in a wall of the sheath, and further comprising pulling the wire or filament to weaken or tear the wall of the sheath to allow the stent to expand.
108. The method of claim 106, further comprising at least partially withdrawing the sheath from the stent to cause a portion of the stent to expand and disengage from the delivery guide.

PCT/US2006/034311

109. The method of claim 106, further comprising everting a portion of the sheath to permit at least a portion of the stent to disengage from the delivery guide.
110. The method of claim 106, further comprising:  
further reducing the stent in diameter by twisting such that a friction between the stent and sheath decreases, and  
withdrawing the sheath from the stent.
111. The method of claim 97, where at least one of the projections comprises a shape selected from L" shape, "T" shape, "V" shape, circular, rectangular, square, polygonal, diamond, triangular, elongate, hook and slot shape.
112. The method of claim 97, where at least one of the projections comprises a hook-shape.



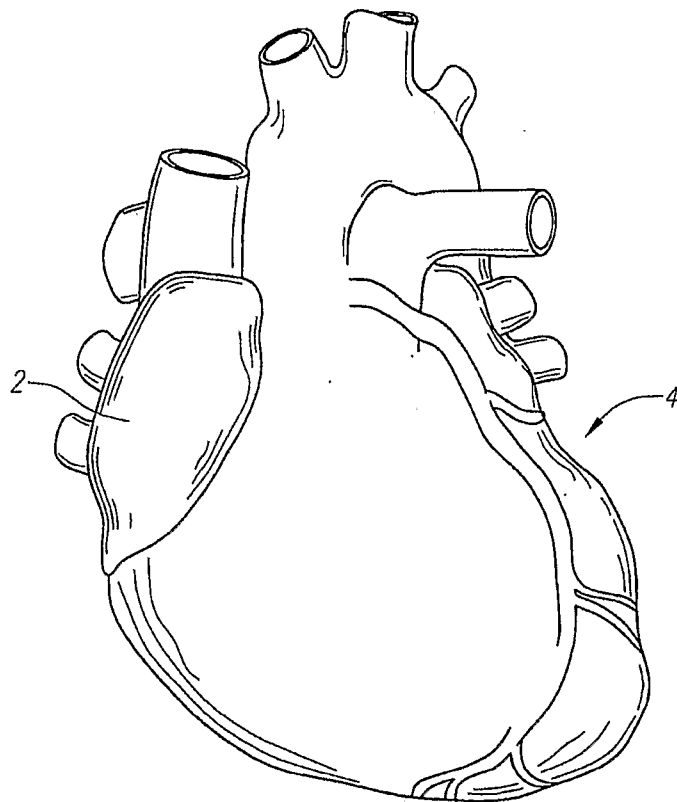

*FIG. 1*



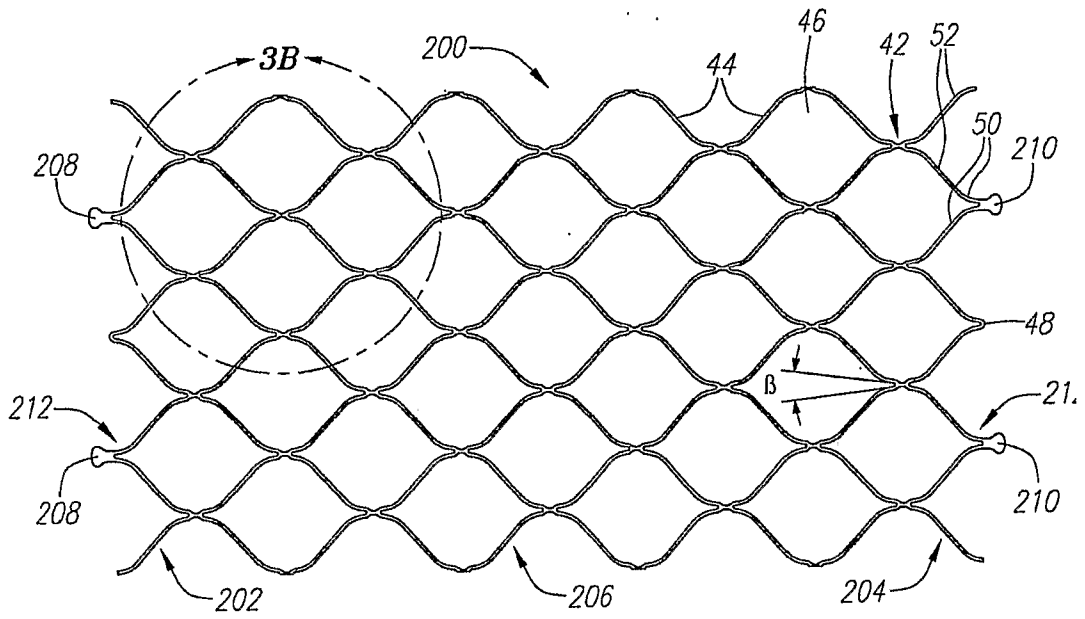

FIG. 3A

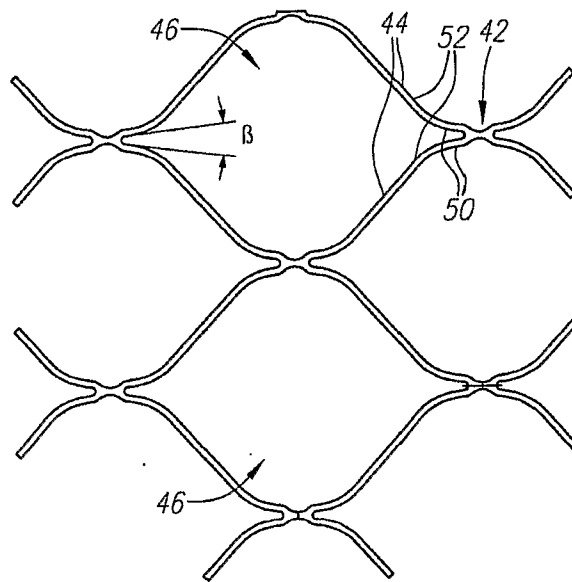

FIG. 3B

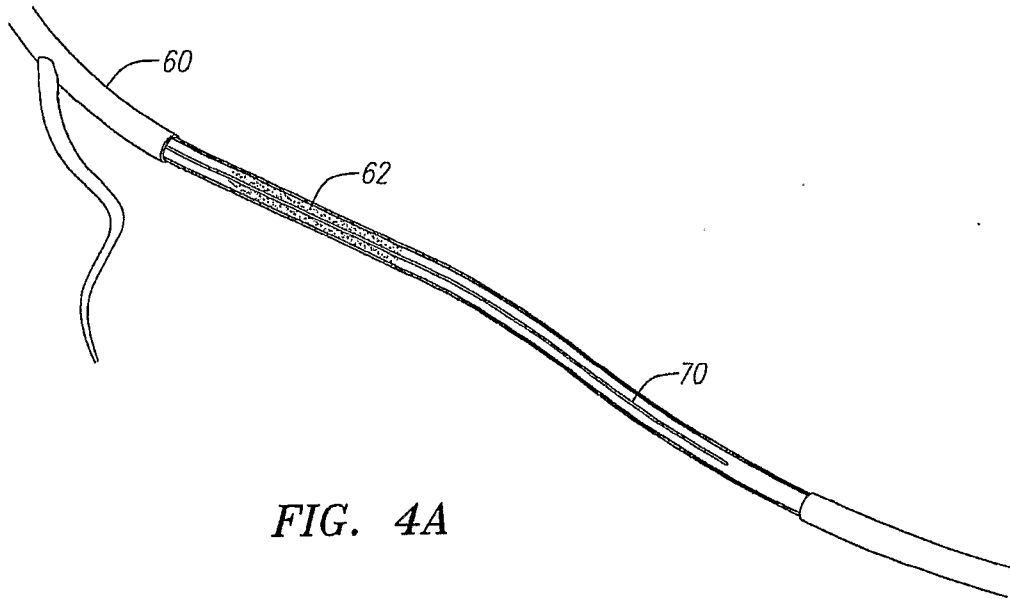

FIG. 4A

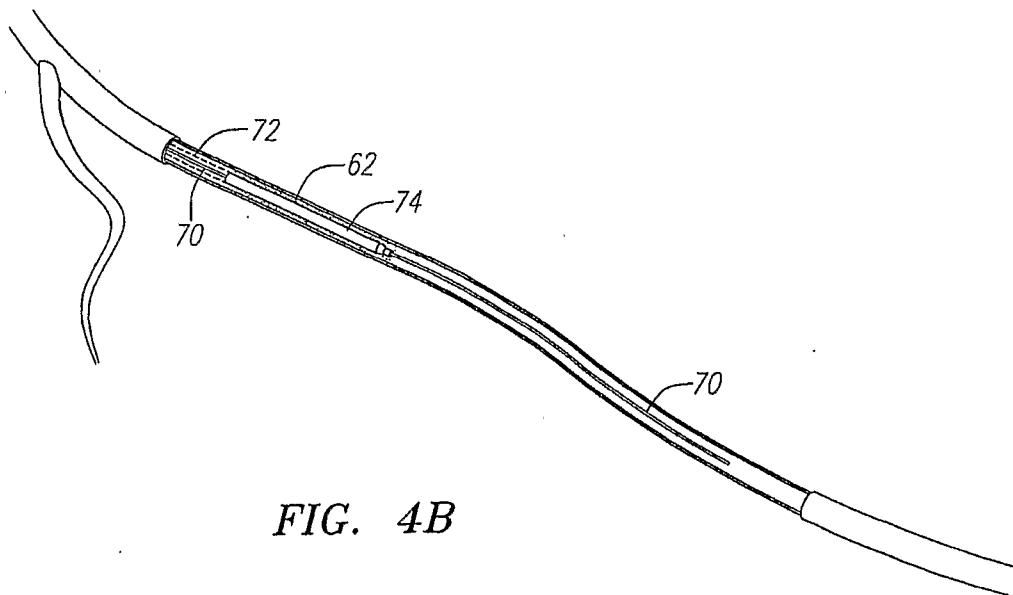

FIG. 4B

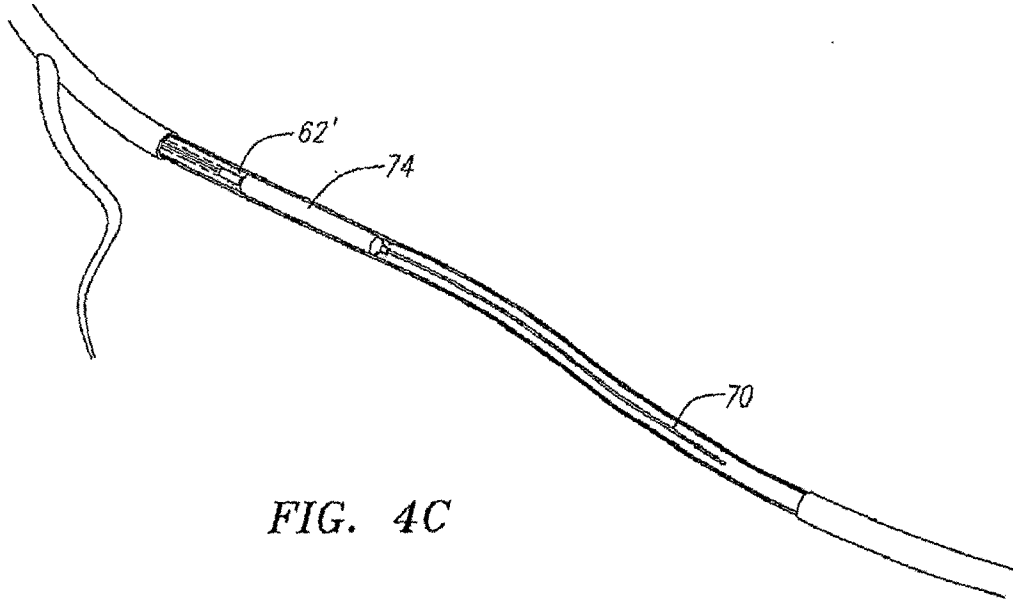

FIG. 4C

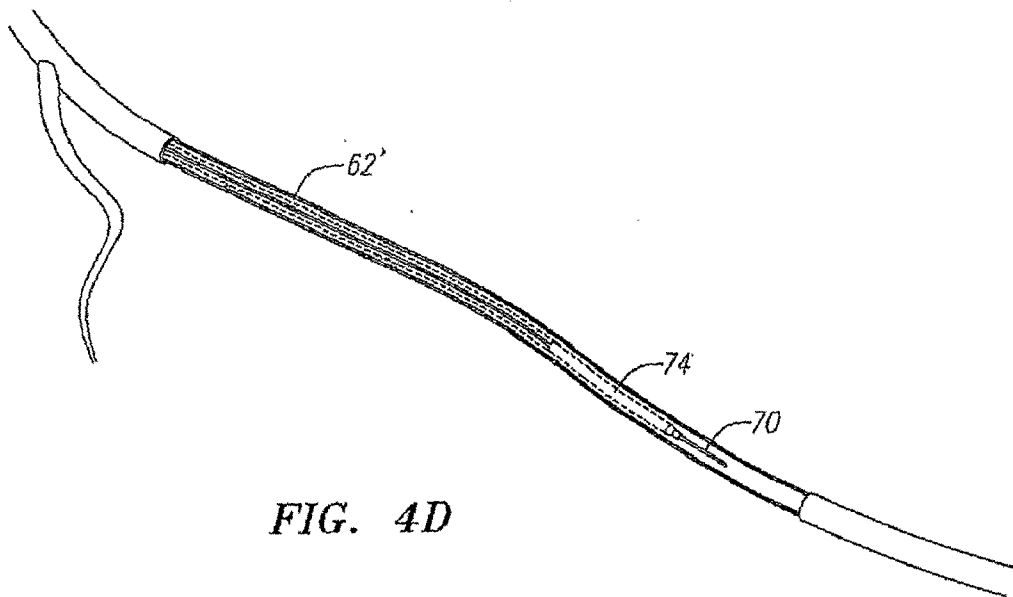

FIG. 4D

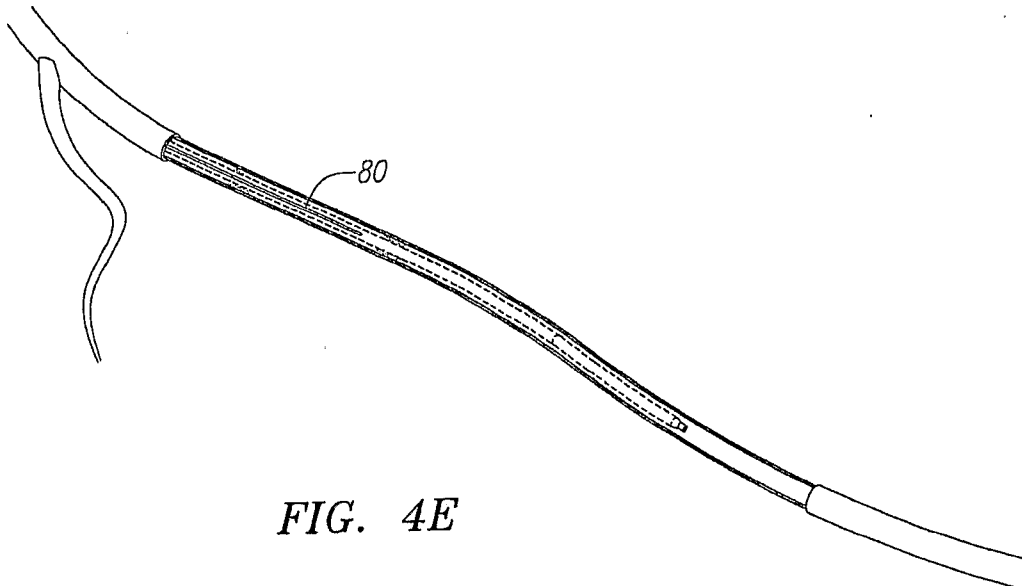

FIG. 4E

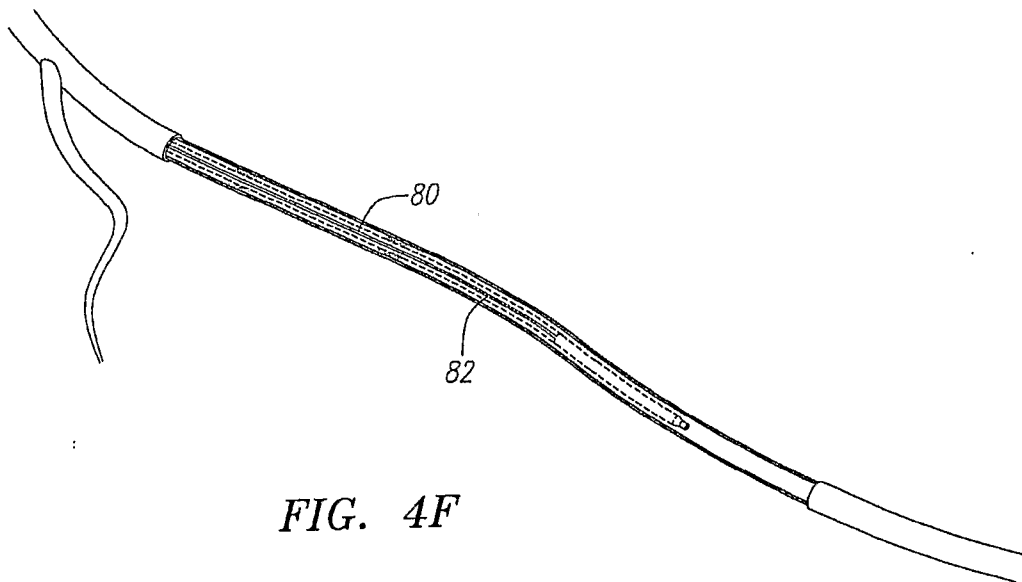
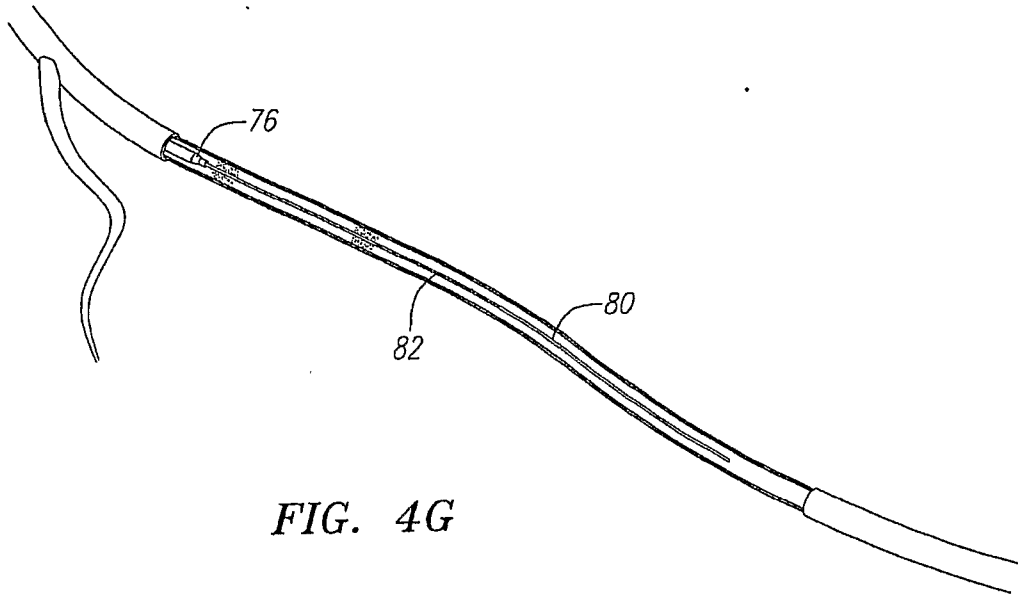
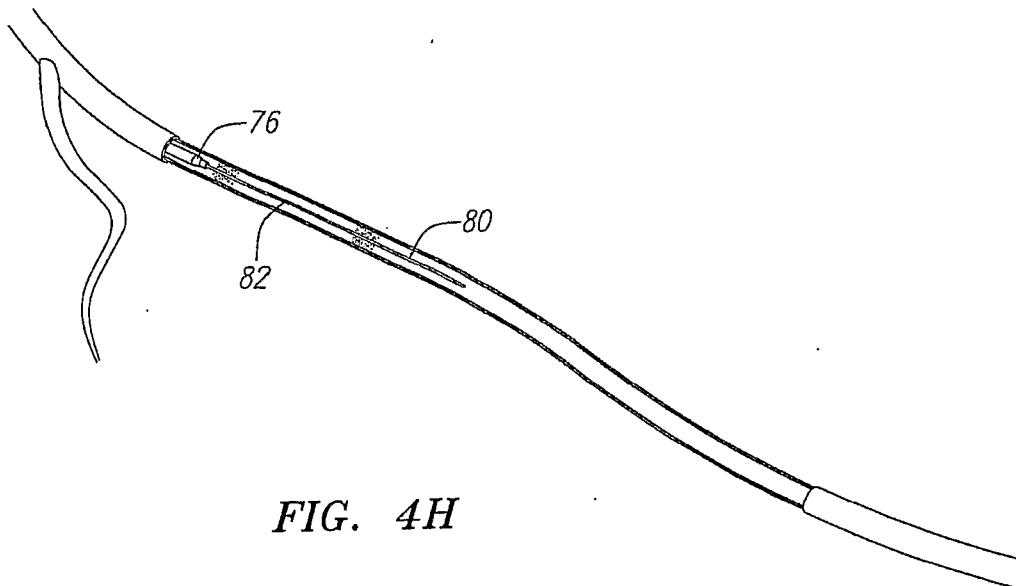

FIG. 4F

7/19



*FIG. 4G*



*FIG. 4H*

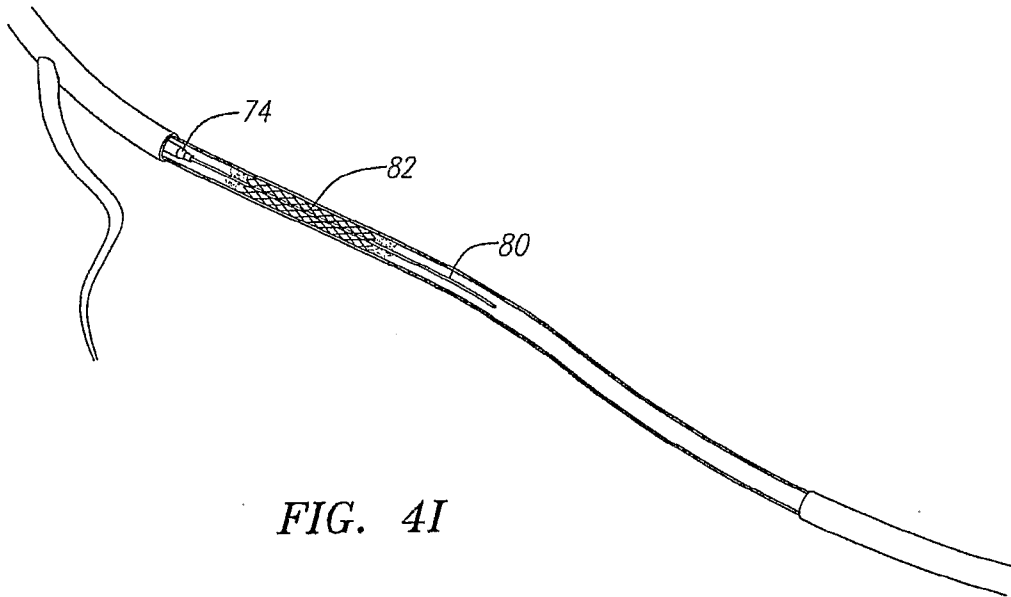

FIG. 4I

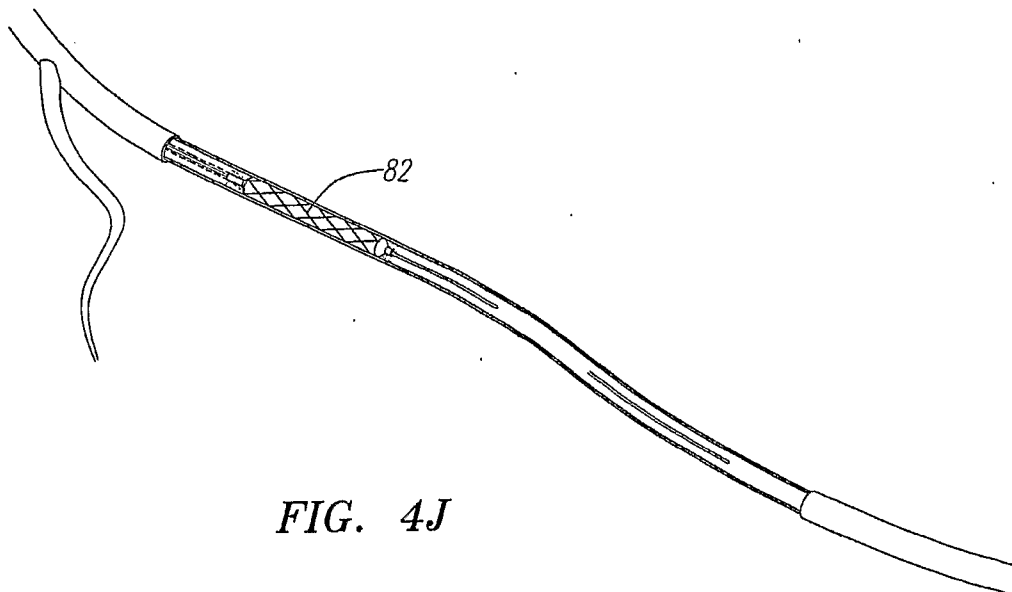

FIG. 4J



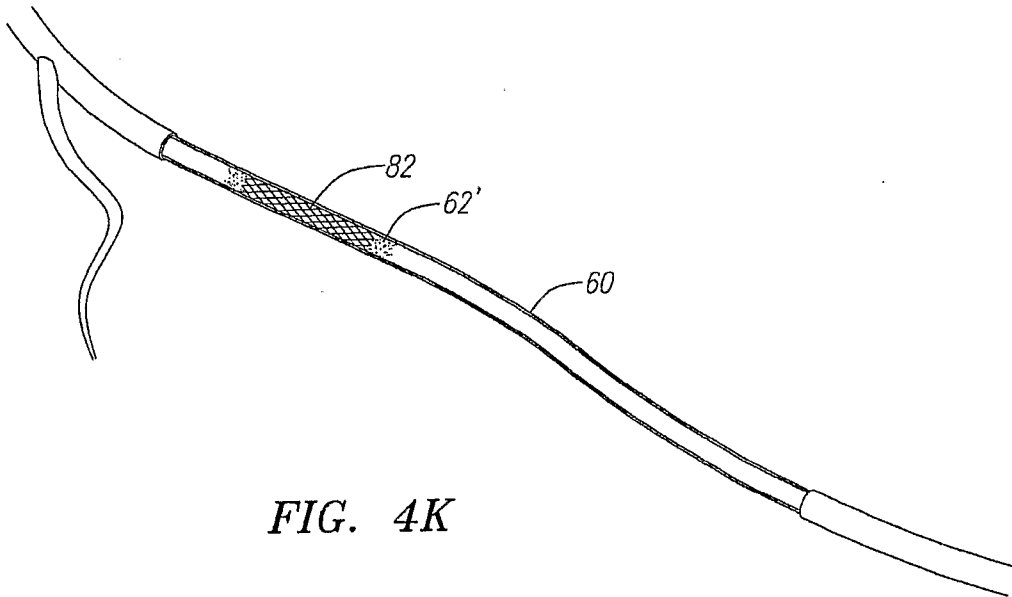

FIG. 4K

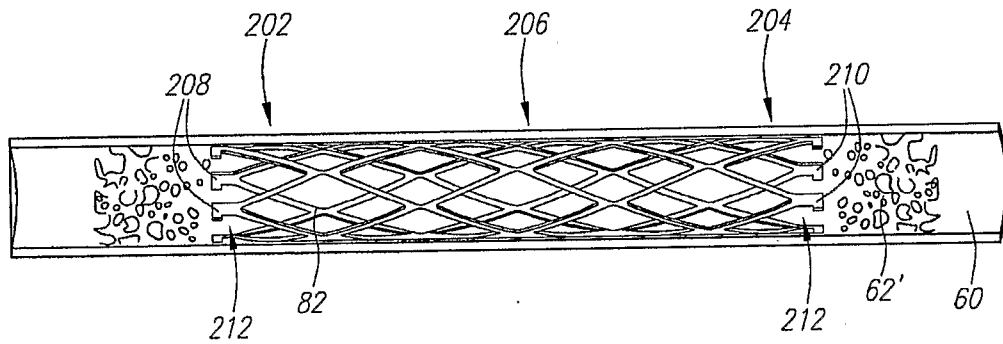
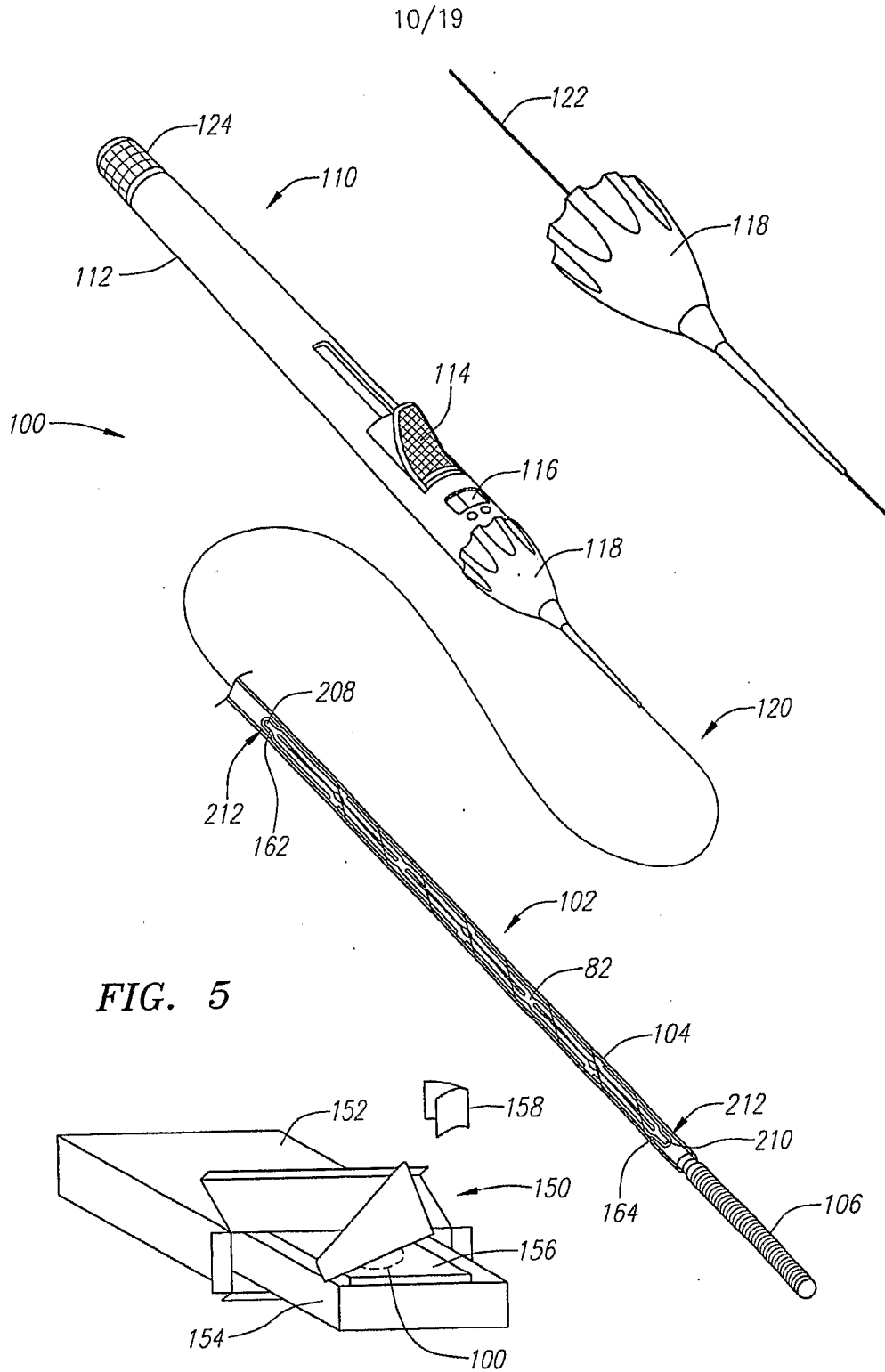

FIG. 4L



11/19

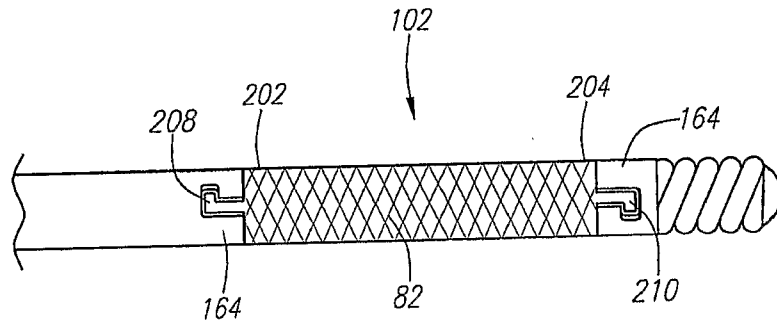

FIG. 6

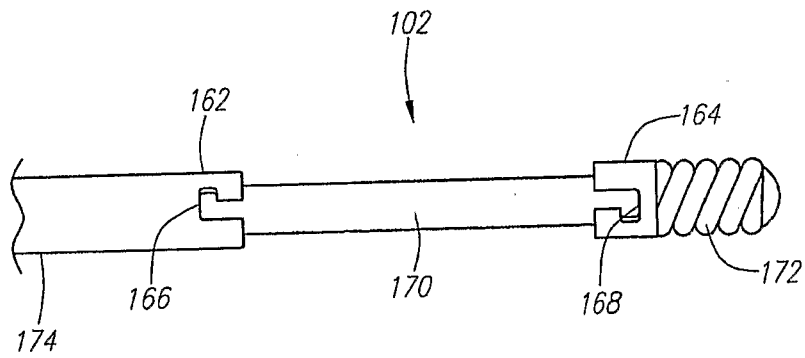
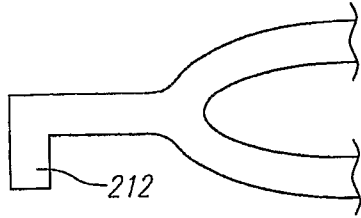
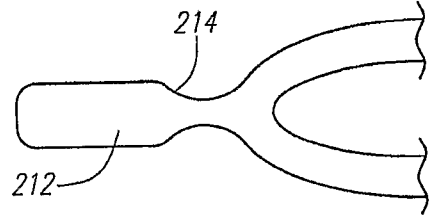

FIG. 7



**FIG. 8A**



**FIG. 8B**

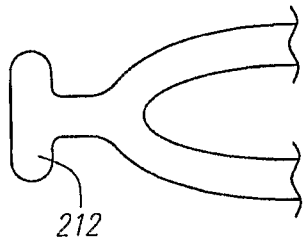

**FIG. 8C**

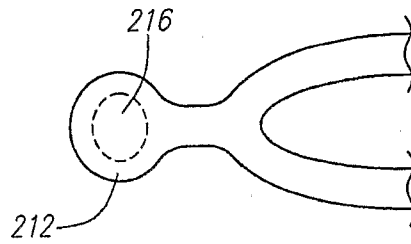

**FIG. 8D**

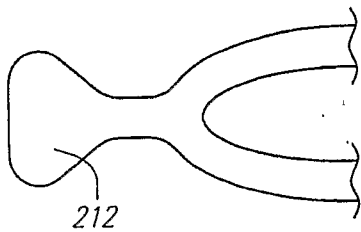

**FIG. 8E**

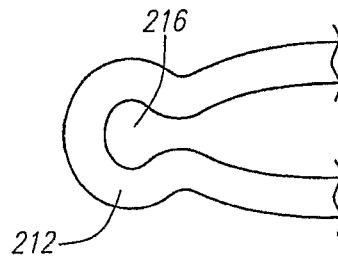

**FIG. 8F**

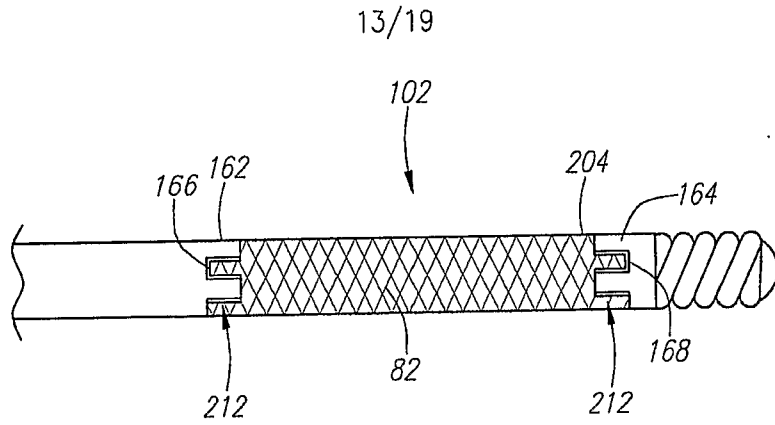

FIG. 9A

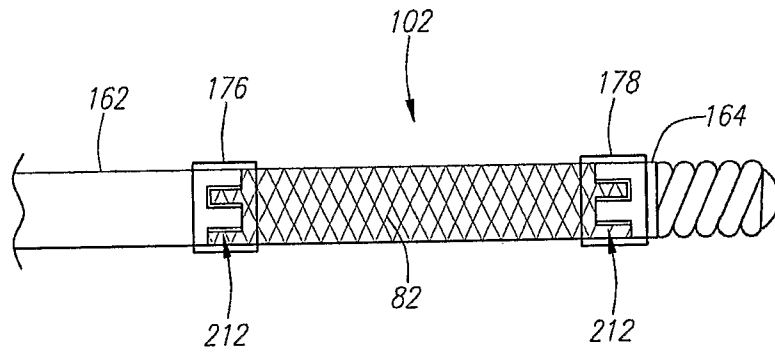

FIG. 9B

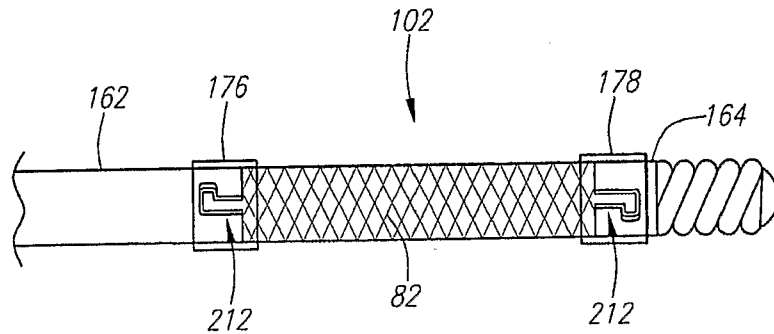

FIG. 9C

14/19

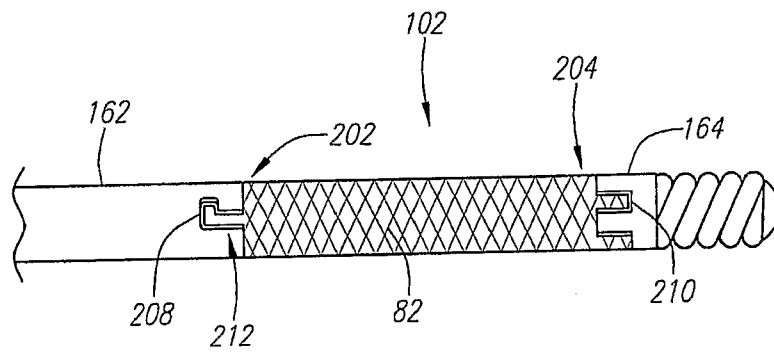

FIG. 10A

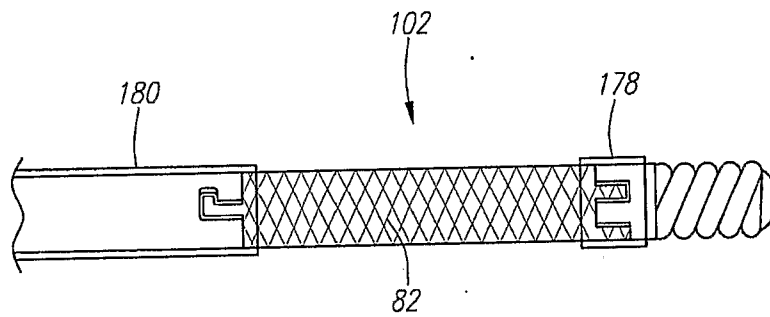

FIG. 10B

15/19

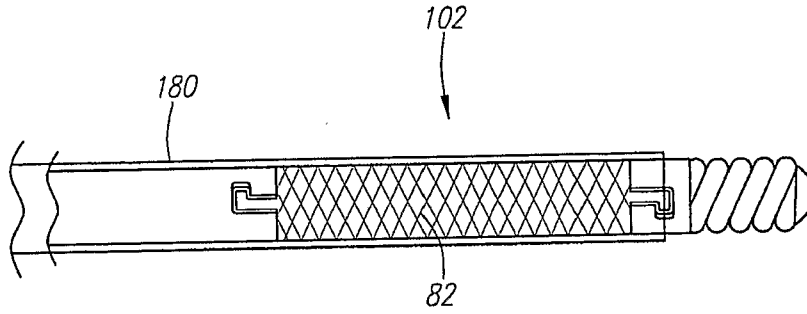

FIG. 11A

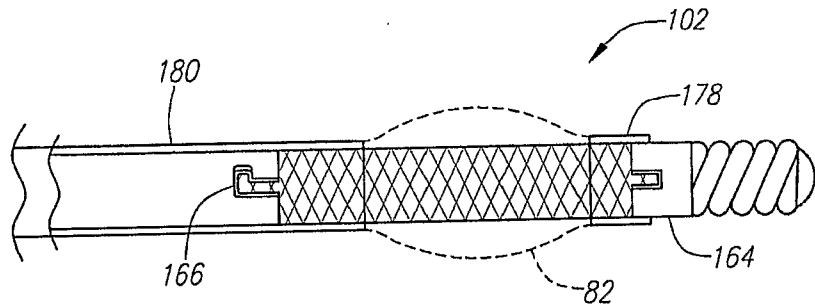

FIG. 11B

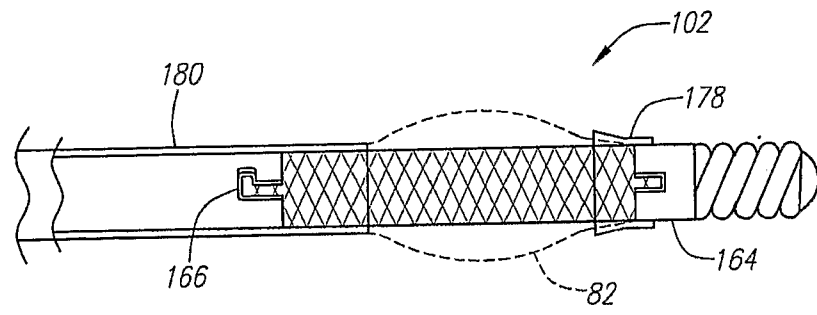
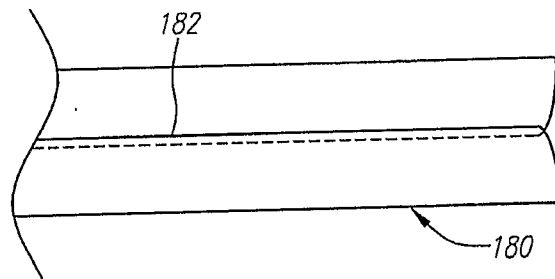
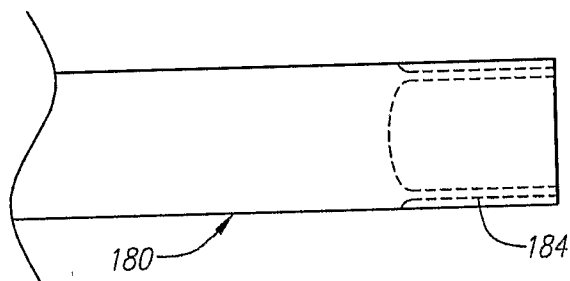

FIG. 11C



**FIG. 11D**



**FIG. 11E**



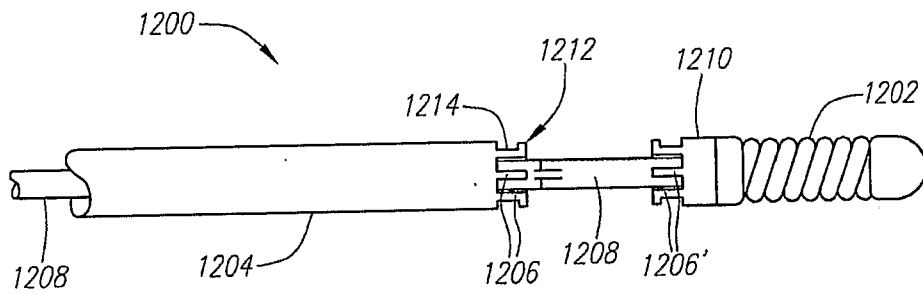

FIG. 12A

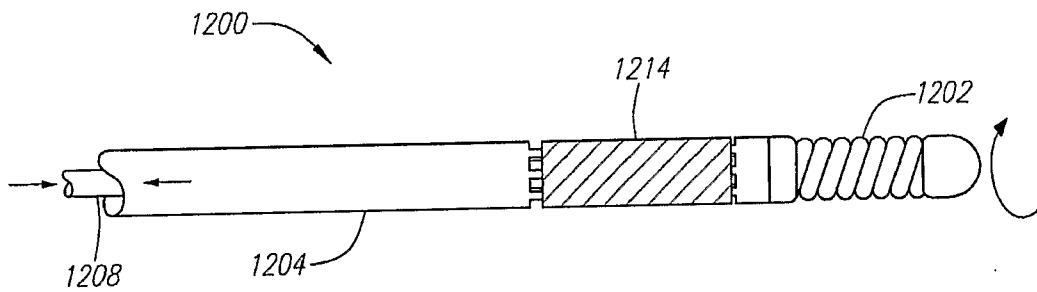

FIG. 12B

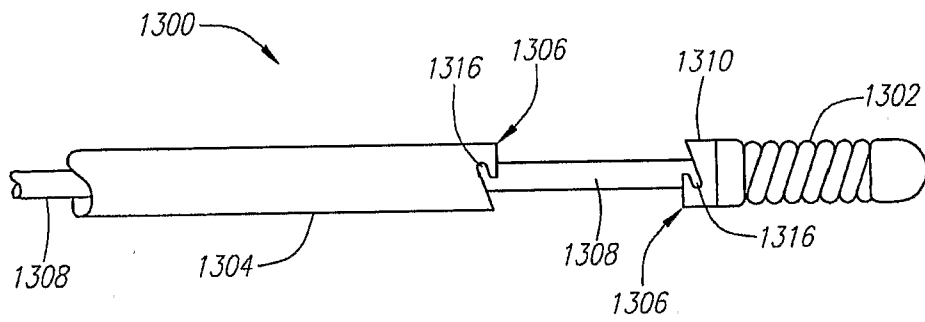

FIG. 13A

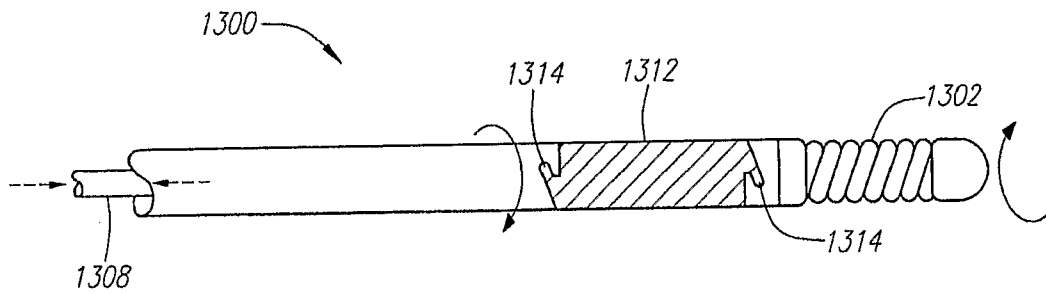
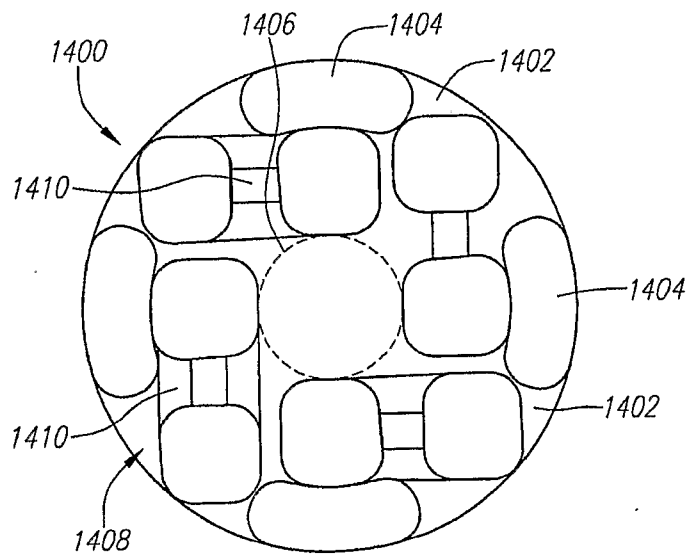
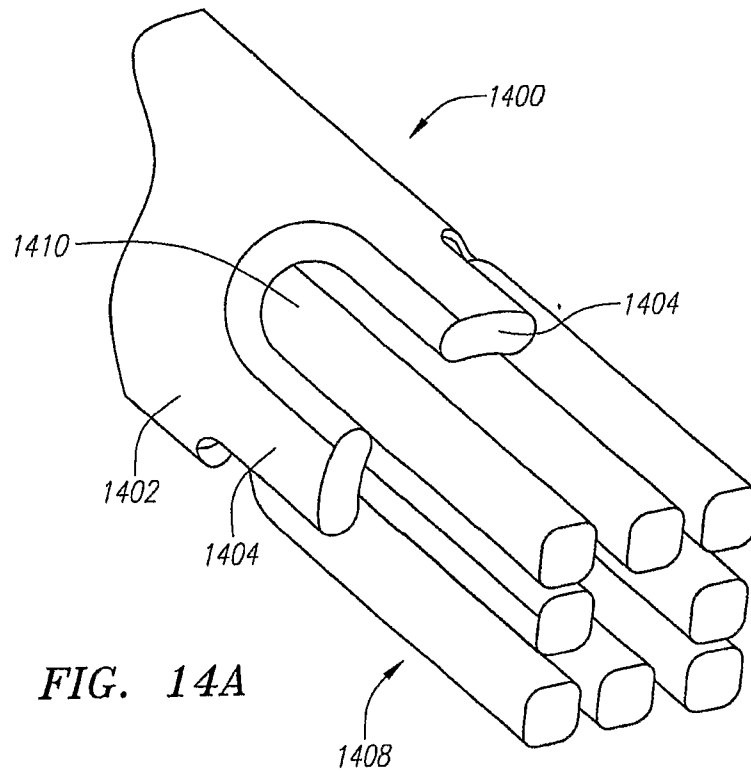

FIG. 13B



# INTERNATIONAL SEARCH REPORT

International application No.

PCT/US 06/34311

<b>A. CLASSIFICATION OF SUBJECT MATTER</b> IPC(8) - A61F 2/06 (2006.01) USPC - 623/1.2 According to International Patent Classification (IPC) or to both national classification and IPC		
<b>B. FIELDS SEARCHED</b> Minimum documentation searched (classification system followed by classification symbols) USPC: 623/1.2; 623/1.11; 623/1.12; 623/1.15; 623/1.18; 623/1.21; 623/1.23 Documentation searched other than minimum documentation to the extent that such documents are included in the fields searched USPC: 623/1.2; 623/1.11; 623/1.12; 623/1.15; 623/1.18; 623/1.21; 623/1.23 (text search - see terms below) Electronic data base consulted during the international search (name of data base and, where practicable, search terms used) PubWEST(USPT,PGPB,EPAB,JPAB); WIPO search Search Term: stent\$; prosthesis; twist; implant		
<b>C. DOCUMENTS CONSIDERED TO BE RELEVANT</b>		
Category*	Citation of document, with indication, where appropriate, of the relevant passages	Relevant to claim No.
Y	WO 1997/048343 A1 (KLEIN, E, J.) 24 December 1997 (24.12.1997), entire document	1-3, 9-21, 23-40, 48-61, 63-72
Y	US 5,108,416 A (RYAN et al.) 28 August 1992 (28.08.1992), Fig 7A. Col. 5-6	1-3, 9-21, 23-40, 48-61, 63-72
<input type="checkbox"/> Further documents are listed in the continuation of Box C. <span style="float: right;"><input type="checkbox"/> 4</span>		
* Special categories of cited documents: "A" document defining the general state of the art which is not considered to be of particular relevance "E" earlier application or patent but published on or after the international filing date "L" document which may throw doubts on priority claim(s) or which is cited to establish the publication date of another citation or other special reason (as specified) "O" document referring to an oral disclosure, use, exhibition or other means "P" document published prior to the international filing date but later than the priority date claimed "T" later document published after the international filing date or priority date and not in conflict with the application but cited to understand the principle or theory underlying the invention "X" document of particular relevance; the claimed invention cannot be considered novel or cannot be considered to involve an inventive step when the document is taken alone "Y" document of particular relevance; the claimed invention cannot be considered to involve an inventive step when the document is combined with one or more other such documents. such combination being obvious to a person skilled in the art "&" document member of the same patent family		
Date of the actual completion of the international search 8 February 2007 (08.02.2007)	Date of mailing of the international search report <div style="font-size: 2em; font-weight: bold; text-align: center;">22 MAR 2007</div>	
Name and mailing address of the ISA/US Mail Stop PCT, Attn: ISA/US, Commissioner for Patents P.O. Box 1450, Alexandria, Virginia 22313-1450 Facsimile No. 571-273-3201	Authorized officer: <div style="text-align: right;">Lee W. Young</div> PCT Helpdesk: 571-272-4300 PCT OSP: 571-272-7774	