

(19) (KR)  
(12) (B1)

(51) 。 Int. Cl. <sup>7</sup> (45) 2003 04 08  
A61B 17/70 (11) 10 - 0379194  
(24) 2003 03 26

(21) 10 - 2001 - 0067394 (65) 0000 - 0000000  
(22) 2001 10 31 (43) 0000 00 00

(73) 529 - 1  
(72) 7 606  
, , . 60612 1063, 1725  
, 60564, 3619  
2 505 6 707

(74)  
:

(54)

, 가 (50) , 가 U (56) ,  
(58) , 가 (74)가 (60) , 가  
가 ,

3

1 ,

2 ,

3 ,

4 ,

5 3 ,

6 3 ,

7 ,

8 ,

9 .

<

50 : 52 :

54 : 56 :

58 : 60 :

68 : 70 :

72 : U 74 :

76 : 78 :

,

.

2000 - 48562 ,

628044

2 가 .

2000 - 48562 1 , (12) 가 (10) ,  
 (12) (14) , (14) (16)  
 가 (16) (R) U 가  
 (18) , (18) (R) (20) .

(12) (22)가 , (22)  
 (24) (18) (20)가  
 (26)가 , (14) (12)가 (28)가  
 (14) (28) (12) (12)

(20) , (R)가 (14) , (14)  
 (16) (10)

6280442 2 , (30) (32) (34)  
 (36) (38) (32) , (3)  
 2) (40) , (40) (36) (R)  
 (42)

(36) (40) (42)가  
 , (42) (R) (40)  
 , (36) (40) (30) (32)  
 (36) , (38) (30) (36)

가 (40)

16) , 2000 - 48562 , ( )  
 (12)가

(38) 6280442 2000 - 48562 ,  
 가

가 , , 가 , 가 , 가 U ,  
가 , , 가 , 가 ,  
가 , , 가 , 가 ,

가 , , 가 ,  
가 , , 가 ,

가

10° , 1°

3 4 , , (52) (54) 가 (R) (  
50) , , (54) (56) , , (54) (56) (R) (R)  
(60)가 (58) . (58) (R)

(50) (52) ,

가

가

가

가

가

가

(50) (54) 가  
(62)

(56) 6 , ,  
(66) (68)  
(54) .

(64)  
(68)가

, , (62)  
 . (68)  
(P3)가 (54)  
(64)

(58) 5 , (56) (54)가  
(70) , (R)가 U (72) .  
(70) (54) 2 (74)가 ,  
(P1)(P2)가 (54) 3 , 4  
(74) (P2) (P1)  
(54)  
(70) (74) , (56) (74)  
(76) , (56) (60)가 (78) .  
(76) (76) (78) , (78)  
(56)  
(78) , (56) (60)  
(H1) (H2)  
(60) (R) 가 (R)가  
(78) (58)  
(60)  
가  
(F1) 가  
(F1) 10° , (F2) 가  
(60) (56) 1° ,  
(78) (60)  
(60) , (78) (80)  
(82) (84)  
(58) (50) (58) (70) (74)  
(54) , (56) (78) (56) , (56) (76)  
(76) (56) (56) (56)

(50) (R) U (66) (72) 가 (54) (56) (62) (50) (60)

(P3)가 (60) (74) (54) (R) (56) (P1)(P2)가 (54) (50)가 (54) (56)

(50) 7 , 26 °

8 (14 N.m) (60) , 가 (54)가 ( )

(MTS 793) , ASTM F1717

9 (F) 가 (R) (M)가 ( ) (50) (M) 76mm 40mm ( )

A , B 6280442 , C 2000 - 48562

300N , 550N , 450N

가 .

(57)

1.

가 , 가 가 U 가 , 가

2.

1 , 가 , 가



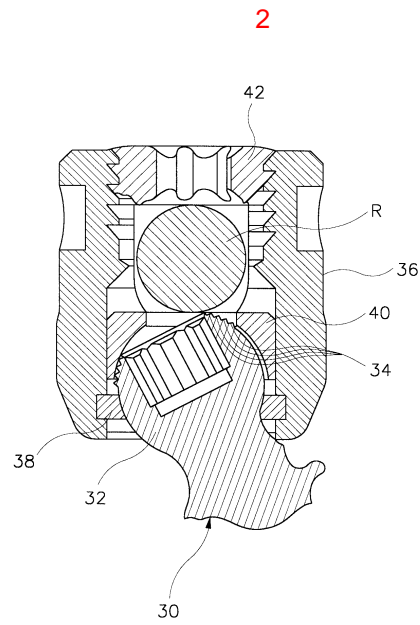
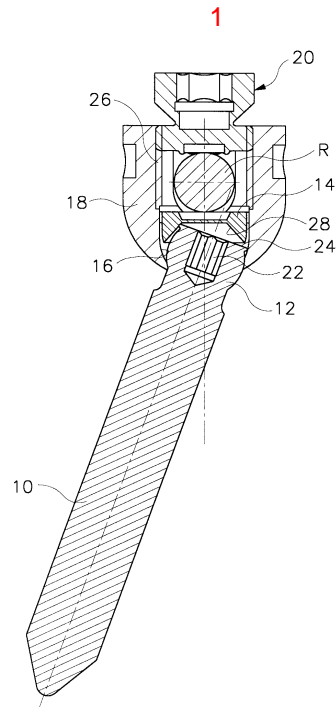



3

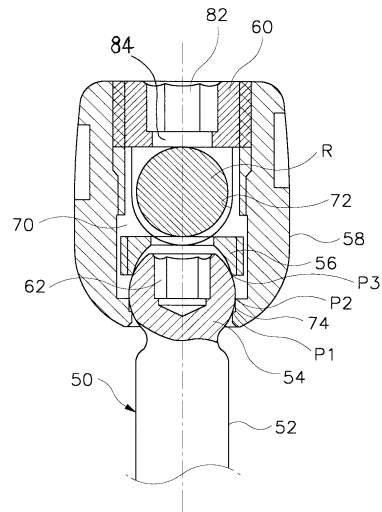

4

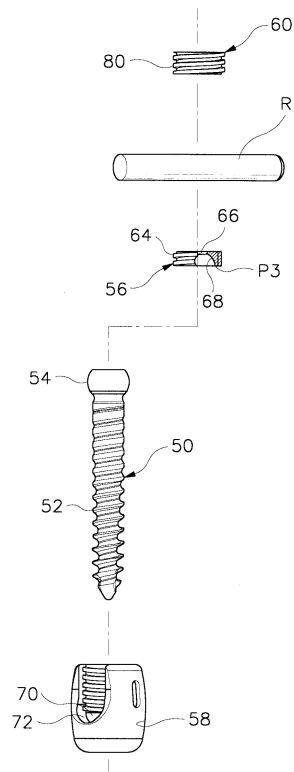

5

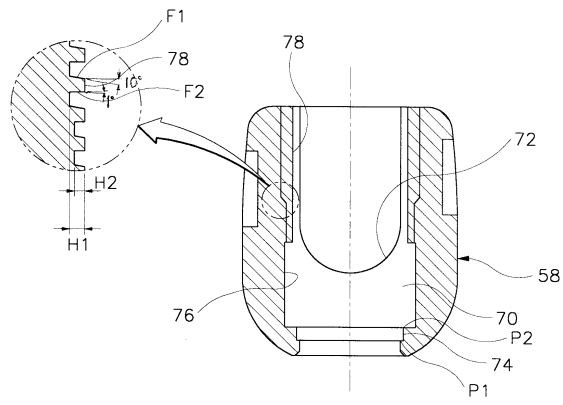

6

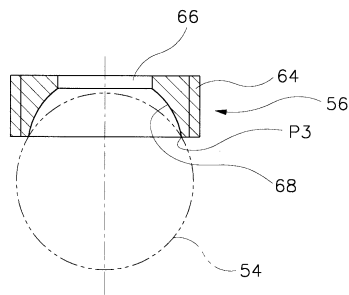

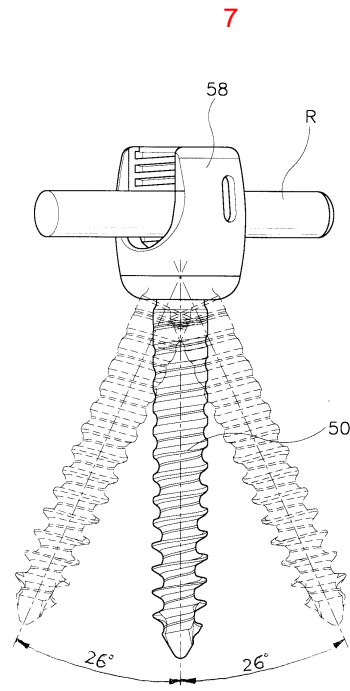

8

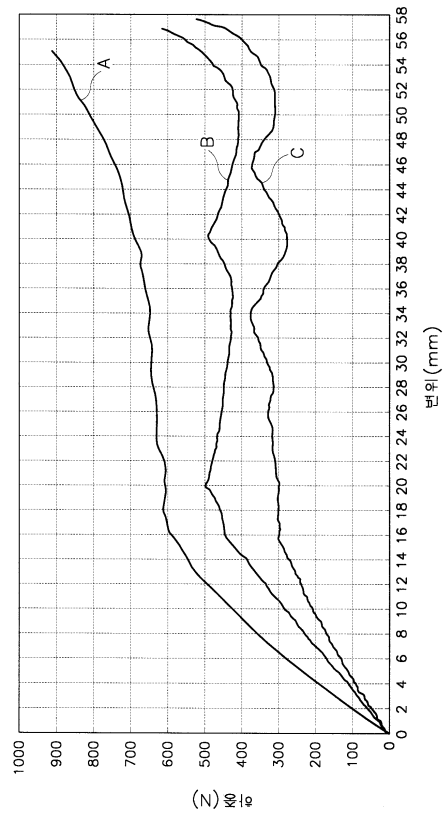

9

