



US010959881B2

(12) **United States Patent**
Muri et al.

(10) **Patent No.:** **US 10,959,881 B2**

(45) **Date of Patent:** **Mar. 30, 2021**

(54) **FLUIDICS CASSETTE FOR OCULAR SURGICAL SYSTEM**

(56) **References Cited**

U.S. PATENT DOCUMENTS

(75) Inventors: **John I. Muri**, Aliso Viejo, CA (US);
Craig Edwards, Mission Viejo, CA (US)

1,848,024 A 3/1932 Owen
2,123,781 A 7/1938 Huber
(Continued)

(73) Assignee: **Johnson & Johnson Surgical Vision, Inc.**, Santa Ana, CA (US)

FOREIGN PATENT DOCUMENTS

AU 2006235983 A1 5/2007
CA 2662797 A 3/2008

(Continued)

(*) Notice: Subject to any disclaimer, the term of this patent is extended or adjusted under 35 U.S.C. 154(b) by 1149 days.

OTHER PUBLICATIONS

(21) Appl. No.: **11/558,435**

International Search Report for Application No. PCT/US07/084163, dated Apr. 1, 2008, 3 pages.

(Continued)

(22) Filed: **Nov. 9, 2006**

Primary Examiner — Andrew J Mensh

(74) *Attorney, Agent, or Firm* — Johnson & Johnson Surgical Vision, Inc.

(65) **Prior Publication Data**

US 2008/0112828 A1 May 15, 2008

(51) **Int. Cl.**

A61M 1/00 (2006.01)

A61F 9/007 (2006.01)

(52) **U.S. Cl.**

CPC **A61F 9/00736** (2013.01); **A61M 1/0058** (2013.01); **A61M 2205/123** (2013.01);

(Continued)

(58) **Field of Classification Search**

CPC A61M 1/0007; A61M 1/0058; A61M 2205/123; A61M 2205/3569; A61M 2205/505; A61M 2205/6018; A61M 2205/6036; A61M 2210/0612; A61F 9/00736

(Continued)

(57)

ABSTRACT

Methods, devices, and systems for laser eye surgery generally make use of a console that interchangeably accepts multiple types of eye treatment cassettes. The cassettes enable one or both of displacement-based or vacuum-based aspiration. The console and the cassette may communicate to establish the functionality of the installed cassette by utilizing a component indigenous to the operation of the cassette. A dual-mode cassette may include a separable holding tank for enabling vacuum-based aspiration. A displacement-based pump may be provided to drain the holding tank while the vacuum system continues to aspirate fluids. A vacuum sensor for controlling the flow of aspirated fluids may have three ports for communicating with a handpiece, a displacement-based pump, a vacuum-based pump, or an irrigation source. The handpiece may be vented during vacuum-based aspiration by opening a vent valve interposed between the handpiece and the vacuum source.

13 Claims, 10 Drawing Sheets

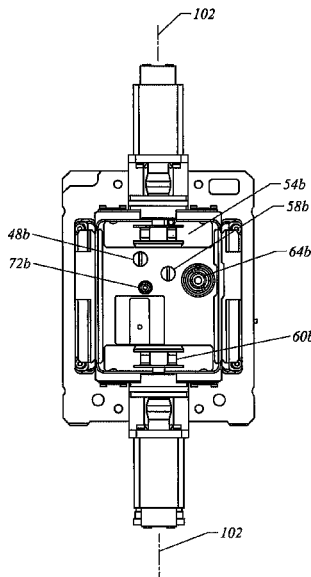

(52) **U.S. Cl.**
 CPC *A61M 2205/3569* (2013.01); *A61M 2205/505* (2013.01); *A61M 2205/6018* (2013.01); *A61M 2205/6036* (2013.01); *A61M 2210/0612* (2013.01)

(58) **Field of Classification Search**
 USPC 604/294
 See application file for complete search history.

(56) **References Cited**
 U.S. PATENT DOCUMENTS

2,990,616 A	7/1961	Balamuth et al.	5,351,676 A	10/1994	Putman
3,076,904 A	2/1963	Kleesattel et al.	5,354,268 A	10/1994	Peterson et al.
3,116,697 A	1/1964	Bilichniansky	5,364,144 A	11/1994	Satterfield et al.
3,439,680 A	4/1969	Thomas, Jr.	5,378,126 A	1/1995	Abrahamson et al.
3,526,219 A	9/1970	Balamuth	5,388,569 A	2/1995	Kepley
3,781,142 A	12/1973	Zweig	5,429,601 A	7/1995	Conley et al.
3,857,387 A	12/1974	Shock	5,445,506 A	8/1995	Aflerbaugh et al.
4,017,828 A	4/1977	Watanabe et al.	5,454,783 A	10/1995	Griehaber et al.
4,037,491 A	7/1977	Newbold	5,464,391 A	11/1995	Devale
4,189,286 A	2/1980	Murry et al.	5,470,211 A	11/1995	Knott et al.
4,193,004 A	3/1980	Lobdell et al.	5,470,312 A	11/1995	Zanger et al.
4,247,784 A	1/1981	Henry	5,499,969 A	3/1996	Beuchat et al.
4,276,023 A	6/1981	Phillips et al.	5,505,330 A	4/1996	Nunes
4,286,464 A	9/1981	Tauber et al.	5,520,652 A	5/1996	Peterson
4,479,760 A	10/1984	Bilstad et al.	5,533,976 A	7/1996	Zaleski et al. 604/153
4,537,561 A	8/1985	Xanthopoulos	5,549,461 A	8/1996	Newland
4,564,342 A	1/1986	Weber et al.	5,554,894 A	9/1996	Sepielli
4,590,934 A	5/1986	Malis et al.	5,558,240 A	9/1996	Karp
4,662,829 A	5/1987	Nehring	5,561,575 A	10/1996	Eways
4,665,621 A	5/1987	Ackerman et al.	5,569,188 A	10/1996	Mackool
4,706,687 A	11/1987	Rogers et al.	5,580,347 A	12/1996	Reimels
4,713,051 A	12/1987	Steppe et al.	5,591,127 A	1/1997	Barwick, Jr. et al.
4,757,814 A	7/1988	Wang et al.	5,653,887 A	8/1997	Wahl et al.
4,758,220 A	7/1988	Sundblom et al.	5,657,000 A	8/1997	Ellingboe
4,758,238 A	7/1988	Sundblom et al.	5,676,530 A	10/1997	Nazarifar
4,772,263 A	9/1988	Dorman et al.	5,676,649 A	10/1997	Boukhny et al.
4,773,897 A	9/1988	Scheller et al.	5,676,650 A	10/1997	Griehaber et al.
4,818,186 A	4/1989	Pastrone et al.	5,693,020 A	12/1997	Rauh
4,819,317 A	4/1989	Bauer et al.	5,697,898 A	12/1997	Devine
4,837,857 A	6/1989	Scheller et al.	5,697,910 A	12/1997	Cole et al.
4,920,336 A	4/1990	Meljer	5,700,240 A	12/1997	Barwick, Jr. et al.
4,920,645 A	5/1990	Baudouin	5,724,264 A	3/1998	Rosenberg et al.
4,921,477 A	5/1990	Davis	5,728,130 A	3/1998	Ishikawa et al.
4,925,444 A	5/1990	Orkin, I et al.	5,733,256 A	3/1998	Costin
4,933,843 A	6/1990	Scheller et al.	5,733,263 A	3/1998	Wheatman
4,941,518 A	7/1990	Williams et al.	5,745,647 A	4/1998	Krause
4,954,960 A	9/1990	Lo et al.	5,746,713 A	5/1998	Hood et al.
4,961,424 A	10/1990	Kubota et al.	5,747,824 A	5/1998	Jung et al.
4,965,417 A	10/1990	Massie	5,752,918 A	5/1998	Fowler et al.
4,983,901 A	1/1991	Lehmer	5,777,602 A	7/1998	Schaller et al.
4,998,972 A	3/1991	Chin et al.	5,805,998 A	9/1998	Kodama
5,006,110 A	4/1991	Garrison et al.	5,807,075 A	9/1998	Jacobsen et al.
5,020,535 A	6/1991	Parker et al.	5,810,765 A	9/1998	Oda
5,026,387 A	6/1991	Thomas	5,810,766 A	9/1998	Barnitz et al.
5,032,939 A	7/1991	Mihara et al.	5,830,176 A	11/1998	Mackool
5,039,973 A	8/1991	Carballo	5,843,109 A	12/1998	Mehta et al.
5,091,656 A	2/1992	Gahn	5,859,642 A	1/1999	Jones
5,108,367 A	4/1992	Epstein et al.	5,871,492 A	2/1999	Sorensen
5,110,270 A	5/1992	Morrisk	5,879,298 A	3/1999	Drobnitzky et al.
5,125,891 A	6/1992	Hossain et al.	5,883,615 A	3/1999	Fago et al.
5,160,317 A	11/1992	Costin	5,899,674 A	5/1999	Jung et al.
5,195,960 A	3/1993	Hossain et al.	5,928,257 A	7/1999	Kablik et al.
5,195,961 A	3/1993	Takahashi et al.	5,938,655 A	8/1999	Bisch et al.
5,195,971 A	3/1993	Sirhan	5,983,749 A	11/1999	Holtorf
5,230,614 A	7/1993	Zanger et al.	6,002,484 A	12/1999	Rozema et al.
5,242,404 A	9/1993	Conley et al.	6,024,428 A	2/2000	Uchikata
5,249,121 A	9/1993	Baum et al.	6,028,387 A	2/2000	Boukhny
5,267,956 A	12/1993	Beuchat	6,036,458 A	3/2000	Cole et al.
5,268,624 A	12/1993	Zanger	D423,349 S	4/2000	Lyons et al.
5,271,379 A	12/1993	Phan et al.	6,062,829 A	5/2000	Ognier
5,282,787 A	2/1994	Wortich	6,077,285 A	6/2000	Boukhny
5,323,543 A	6/1994	Steen et al.	6,086,598 A	7/2000	Appelbaum et al.
5,342,293 A	8/1994	Zanger	6,109,895 A	8/2000	Ray et al.
5,350,357 A	9/1994	Kamen et al.	6,117,126 A	9/2000	Applebaum et al.
			6,139,320 A	10/2000	Hahn
			6,150,623 A	11/2000	Chen
			6,159,175 A	12/2000	Strukel et al.
			6,179,829 B1	1/2001	Bisch et al.
			6,200,287 B1	3/2001	Keller et al.
			6,219,032 B1	4/2001	Rosenberg et al.
			6,251,113 B1	6/2001	Appelbaum et al.
			6,260,434 B1	7/2001	Holtorf
			6,360,630 B2	3/2002	Holtorf
			6,368,269 B1	4/2002	Lane
			6,383,804 B1	5/2002	Ward, Jr. et al.
			6,411,062 B1	6/2002	Baranowski et al.
			6,424,124 B2	7/2002	Ichihara et al.
			6,436,072 B1	8/2002	Kullas et al.
			6,452,120 B1	9/2002	Chen

(56)

References Cited

U.S. PATENT DOCUMENTS

6,452,123	B1	9/2002	Chen	2004/0092922	A1	5/2004	Kadziauskas et al.
6,491,661	B1	12/2002	Boukhny et al.	2004/0097868	A1	5/2004	Kadziauskas et al.
6,511,454	B1	1/2003	Nakao et al.	2004/0127840	A1	7/2004	Gara et al.
6,537,445	B2	3/2003	Muller	2004/0193182	A1	9/2004	Yaguchi et al.
6,561,999	B1	5/2003	Nazarifar et al.	2004/0212344	A1	10/2004	Tamura et al.
6,595,948	B2	7/2003	Suzuki et al.	2004/0215127	A1	10/2004	Kadziauskas et al.
6,632,214	B2	10/2003	Morgan et al.	2004/0224641	A1	11/2004	Sinn
6,674,030	B2	1/2004	Chen et al.	2004/0253129	A1	12/2004	Sorensen et al.
6,830,555	B2	12/2004	Rockley et al.	2005/0039567	A1	2/2005	Peterson et al.
6,852,092	B2	2/2005	Kadziauskas et al.	2005/0054971	A1	3/2005	Steen et al.
6,862,951	B2	3/2005	Peterson et al.	2005/0065462	A1	3/2005	Nazarifar et al.
6,908,451	B2	6/2005	Brody et al.	2005/0069419	A1	3/2005	Cull et al.
6,962,488	B2	11/2005	Davis et al.	2005/0070859	A1	3/2005	Cull et al.
6,962,581	B2	11/2005	Thoe	2005/0070871	A1	3/2005	Lawton et al.
6,986,753	B2	1/2006	Bui	2005/0095153	A1	5/2005	Demers et al.
7,011,761	B2	3/2006	Muller	2005/0103607	A1	5/2005	Mezhinsky
7,012,203	B2	3/2006	Hanson et al.	2005/0109595	A1	5/2005	Mezhinsky et al.
7,070,578	B2	7/2006	Leukanech et al.	2005/0118048	A1	6/2005	Traxinger
7,073,083	B2	7/2006	Litwin, Jr. et al.	2005/0119679	A1	6/2005	Rabiner et al.
7,087,049	B2	8/2006	Nowlin et al.	2005/0130098	A1	6/2005	Warner
7,103,344	B2	9/2006	Menard	2005/0187513	A1	8/2005	Rabiner et al.
7,167,723	B2	1/2007	Zhang	2005/0197131	A1	9/2005	Ikegami
7,168,930	B2	1/2007	Cull et al.	2005/0209552	A1	9/2005	Beck et al.
7,169,123	B2	1/2007	Kadziauskas et al.	2005/0209560	A1	9/2005	Boukhny et al.
7,236,766	B2	6/2007	Freeburg	2005/0228266	A1	10/2005	McCombs
7,236,809	B2	6/2007	Fischedick et al.	2005/0236936	A1	10/2005	Shiv et al.
7,242,765	B2	7/2007	Hairston	2005/0245888	A1	11/2005	Cull
7,244,240	B2*	7/2007	Nazarifar et al. 604/30	2005/0261628	A1	11/2005	Boukhny et al.
7,289,825	B2	10/2007	Fors et al.	2005/0267504	A1	12/2005	Boukhny et al.
7,300,264	B2	11/2007	Souza	2006/0035585	A1	2/2006	Washiro
7,316,664	B2	1/2008	Kadziauskas et al.	2006/0036180	A1	2/2006	Boukhny et al.
7,336,976	B2	2/2008	Ito	2006/0041220	A1	2/2006	Boukhny et al.
7,381,917	B2	6/2008	Dacquay et al.	2006/0046659	A1	3/2006	Haartsen et al.
7,439,463	B2	10/2008	Brenner et al.	2006/0074405	A1	4/2006	Malackowski et al.
7,465,285	B2	12/2008	Hutchinson et al.	2006/0078448	A1	4/2006	Holden
7,470,277	B2	12/2008	Finlay et al.	2006/0114175	A1	6/2006	Boukhny
7,526,038	B2	4/2009	McNamara	2006/0145540	A1	7/2006	Mezhinsky
7,591,639	B2	9/2009	Kent	2006/0219049	A1	10/2006	Horvath et al.
7,731,484	B2	6/2010	Yamamoto et al.	2006/0219962	A1	10/2006	Dancs et al.
7,776,006	B2	8/2010	Childers et al.	2006/0224107	A1	10/2006	Claus et al.
7,785,316	B2	8/2010	Claus et al.	2006/0236242	A1	10/2006	Boukhny et al.
7,811,255	B2	10/2010	Boukhny et al.	2007/0016174	A1	1/2007	Millman et al.
7,883,521	B2	2/2011	Rockley et al.	2007/0049898	A1	3/2007	Hopkins et al.
7,921,017	B2	4/2011	Claus	2007/0060926	A1	3/2007	Escaf
7,967,777	B2*	6/2011	Edwards et al. 604/30	2007/0073214	A1	3/2007	Dacquay et al.
8,070,712	B2*	12/2011	Muri et al. 604/30	2007/0073309	A1	3/2007	Kadziauskas et al.
8,075,468	B2	12/2011	Min et al.	2007/0078379	A1	4/2007	Boukhny et al.
D693,463	S	11/2013	Burger et al.	2007/0085611	A1	4/2007	Gerry et al.
D698,019	S	1/2014	Oliveira	2007/0107490	A1*	5/2007	Artsyukhovich et al. 73/1.16
9,033,940	B2	5/2015	Muri et al.	2007/0231205	A1	10/2007	Williams et al.
9,658,468	B2	5/2017	Dai	2007/0248477	A1	10/2007	Nazarifar et al.
2001/0023331	A1	9/2001	Kanda et al.	2007/0249942	A1	10/2007	Salehi et al.
2001/0047166	A1	11/2001	Wuchinich	2007/0252395	A1	11/2007	Williams et al.
2001/0051788	A1	12/2001	Paukovits et al.	2007/0287959	A1	12/2007	Walter et al.
2002/0004657	A1	1/2002	Morgan et al.	2008/0033342	A1	2/2008	Staggs
2002/0007671	A1	1/2002	Lavi et al.	2008/0066542	A1	3/2008	Gao
2002/0019215	A1	2/2002	Romans	2008/0067046	A1	3/2008	Dacquay et al.
2002/0019607	A1	2/2002	Bui	2008/0082040	A1	4/2008	Kubler et al.
2002/0045887	A1	4/2002	Dehoogh et al.	2008/0112828	A1	5/2008	Muri et al.
2002/0070840	A1	6/2002	Fischer et al.	2008/0114289	A1	5/2008	Muri et al.
2002/0098859	A1	7/2002	Murata	2008/0114290	A1	5/2008	King et al.
2002/0137007	A1	9/2002	Beerstecher	2008/0114291	A1*	5/2008	Muri et al. 604/35
2002/0179462	A1	12/2002	Silvers	2008/0114300	A1	5/2008	Muri et al.
2002/0183693	A1	12/2002	Peterson et al.	2008/0114311	A1*	5/2008	Muri et al. 604/294
2003/0028091	A1	2/2003	Simon et al.	2008/0114312	A1	5/2008	Muri et al.
2003/0050619	A1	3/2003	Mooijman et al.	2008/0114372	A1	5/2008	Edwards et al.
2003/0073980	A1	4/2003	Finlay et al.	2008/0114387	A1	5/2008	Hertweck et al.
2003/0083016	A1	5/2003	Evans et al.	2008/0125694	A1	5/2008	Domash
2003/0108429	A1	6/2003	Angelini et al.	2008/0125695	A1	5/2008	Hopkins et al.
2003/0125717	A1	7/2003	Whitman	2008/0125697	A1	5/2008	Gao
2003/0224729	A1	12/2003	Arnold	2008/0125698	A1	5/2008	Gerg et al.
2003/0226091	A1	12/2003	Platenberg et al.	2008/0129695	A1	6/2008	Li
2004/0019313	A1	1/2004	Childers et al.	2008/0146989	A1	6/2008	Zacharias
2004/0037724	A1	2/2004	Haser et al.	2008/0200878	A1	8/2008	Davis et al.
2004/0068300	A1	4/2004	Kadziauskas et al.	2008/0243105	A1	10/2008	Horvath
				2008/0262476	A1	10/2008	Krause et al.
				2008/0281253	A1	11/2008	Injev et al.
				2008/0294087	A1	11/2008	Steen et al.
				2008/0312594	A1	12/2008	Urich et al.

(56)

References Cited

U.S. PATENT DOCUMENTS

2009/0005712 A1 1/2009 Raney
 2009/0005789 A1 1/2009 Charles
 2009/0048607 A1 2/2009 Rockley
 2009/0087327 A1 4/2009 Voltenburg, Jr. et al.
 2009/0124974 A1 5/2009 Crank et al.
 2009/0163853 A1 6/2009 Cull et al.
 2010/0036256 A1 2/2010 Boukhny et al.
 2010/0057016 A1 3/2010 Dale et al.
 2010/0069825 A1 3/2010 Raney
 2010/0069828 A1 3/2010 Steen et al.
 2010/0140149 A1 6/2010 Fulkerson et al.
 2010/0152685 A1 6/2010 Goh
 2010/0185150 A1 7/2010 Zacharias
 2010/0249693 A1 9/2010 Links
 2010/0280435 A1 11/2010 Raney et al.
 2011/0092887 A1 4/2011 Wong et al.
 2011/0092924 A1 4/2011 Wong et al.
 2011/0092962 A1 4/2011 Ma et al.
 2011/0098721 A1 4/2011 Tran et al.
 2011/0160646 A1 6/2011 Kadziauskas et al.
 2011/0208047 A1 8/2011 Fago
 2011/0251569 A1 10/2011 Turner et al.
 2011/0300010 A1 12/2011 Jarnagin et al.
 2012/0065580 A1 3/2012 Gerg et al.
 2012/0078181 A1 3/2012 Smith et al.
 2012/0083735 A1 4/2012 Pfouts
 2012/0083736 A1 4/2012 Pfouts et al.
 2012/0083800 A1 4/2012 Andersohn
 2013/0072853 A1 3/2013 Wong et al.
 2013/0169412 A1 7/2013 Roth
 2013/0184638 A1 7/2013 Scarpaci et al.
 2013/0184676 A1 7/2013 Kamen et al.
 2013/0245543 A1 9/2013 Gerg et al.
 2013/0267892 A1 10/2013 Woolford
 2013/0289475 A1 10/2013 Muri et al.
 2013/0303978 A1 11/2013 Ross
 2013/0336814 A1 12/2013 Kamen et al.
 2014/0178215 A1 6/2014 Baxter et al.
 2014/0188076 A1 7/2014 Kamen et al.
 2014/0276424 A1 9/2014 Davis et al.
 2016/0151564 A1 6/2016 Magers et al.

JP 2005195653 A 7/2005
 JP 2008188110 A 8/2008
 WO 9220310 A1 11/1992
 WO WO-9315777 A2 8/1993
 WO WO 93/24082 12/1993
 WO WO-9405346 A1 3/1994
 WO WO-9632144 A1 10/1996
 WO 9737700 A1 10/1997
 WO WO 98/18507 5/1998
 WO 99/17818 4/1999
 WO WO 99/17818 * 4/1999 A61M 1/00
 WO 0000096 A1 1/2000
 WO WO-0070225 A1 11/2000
 WO WO-0122696 A1 3/2001
 WO 0226286 A2 4/2002
 WO WO-0228449 A2 4/2002
 WO 02/34314 A1 5/2002
 WO WO 02/34314 A1 * 5/2002 A61M 1/36
 WO WO-03102878 A1 12/2003
 WO WO-04096360 A1 11/2004
 WO WO-2004114180 A1 12/2004
 WO WO 2005/084728 9/2005
 WO 05092047 A2 10/2005
 WO WO-05092023 A2 10/2005
 WO 06101908 A2 9/2006
 WO 06125280 A1 11/2006
 WO WO 93/17729 11/2006
 WO 2007121144 A1 10/2007
 WO 2007143797 A1 12/2007
 WO WO 2007/143677 A2 12/2007
 WO WO-2007149637 A2 12/2007
 WO 2008030872 A1 3/2008
 WO 2008060995 A1 5/2008
 WO WO-2008060859 A1 5/2008
 WO WO-2008060902 A1 5/2008
 WO 2009123547 A1 10/2009
 WO 2010054146 A1 5/2010
 WO 2010054225 A2 5/2010
 WO 2010151704 A1 12/2010
 WO 2012151062 A1 11/2012
 WO WO-2013142009 A1 9/2013
 WO 2015009945 A1 1/2015

OTHER PUBLICATIONS

“Phacoemulsification. Oct. 12, 2006. Wikipedia.com. Jun. 19, 2009 <http://en.wikipedia.org/wiki/Phacoemulsification>.”
 Boyd, “Preparing for the Transition” in: The Art and the Science of Cataract Surgery, Chapter 7, 2001, pp. 93-133.
 Co-pending U.S. Appl. No. 13/922,475, filed Jun. 20, 2013.
 English Human Translation of JP57024482 from Feb. 9, 1982.
 International Preliminary Report on Patentability and Written Opinion for Application No. PCT/US07/083875, dated May 12, 2009, 8 pages.
 International Preliminary Report on Patentability and Written Opinion for Application No. PCT/US07/084157, dated May 12, 2009, 10 pages.
 International Search Report for Application No. PCT/US07/083875, dated May 7, 2008, 4 pages.
 International Search Report for Application No. PCT/US07/083880, dated May 30, 2008, 4 pages.
 International Search Report for Application No. PCT/US07/084157, dated Apr. 1, 2008, 3 pages.
 International Search Report for Application No. PCT/US08/064240, dated Oct. 29, 2008, 3 pages.
 International Search Report for Application No. PCT/US08/071704, dated Nov. 26, 2008, 3 pages.
 International Search Report for Application No. PCT/US08/072974, dated Feb. 23, 2009, 2 pages.
 International Search Report for Application No. PCT/US2009/052473, dated Nov. 2, 2009, 3 pages.
 Definition of “Parameter”, Retrieved from the Internet:< URL: <http://dictionary.reference.com/browse/parameter>>.
 European Search Report for Application No. EP10164058, dated Jun. 25, 2010, 2 pages.

FOREIGN PATENT DOCUMENTS

DE 3826414 A1 2/1989
 EP 56019 A1 7/1982
 EP 424687 A1 5/1991
 EP 619993 A1 10/1994
 EP 1010437 A1 6/2000
 EP 1072285 A1 1/2001
 EP 1113562 A1 7/2001
 EP 1310267 5/2003
 EP 1464310 A1 10/2004
 EP 1469440 A2 10/2004
 EP 1550406 A2 7/2005
 EP 1704839 A1 9/2006
 EP 1 787 606 A1 * 5/2007 A61F 9/007
 EP 1779879 A1 5/2007
 EP 1787606 A1 5/2007
 EP 1849443 A1 10/2007
 EP 1849444 A1 10/2007
 EP 1857128 A1 11/2007
 EP 1310267 B1 1/2008
 EP 1873501 A1 1/2008
 EP 1900347 A1 3/2008
 EP 1925274 A2 5/2008
 EP 1867349 11/2008
 EP 1867349 B1 11/2008
 ES 2264369 A1 12/2006
 GB 2230301 A 10/1990
 GB 2352887 A 2/2001
 GB 2438679 A 12/2007
 JP 57024482 A 2/1982
 JP S58167333 A 10/1983
 JP S62204463 A 9/1987

(56)

References Cited

OTHER PUBLICATIONS

European Search Report for Application No. EP13184138.9, dated Oct. 24, 2013, 7 pages.

Examination Report dated Mar. 28, 2012 for European Application No. EP09791072 filed Jul. 31, 2009, 3 pages.

International Preliminary Report on Patentability and Written Opinion for Application No. PCT/US07/083880, dated May 12, 2009, 7 pages.

International Preliminary Report on Patentability and Written Opinion for Application No. PCT/US07/084163, dated May 12, 2009, 8 pages.

International Preliminary Report on Patentability and Written Opinion for Application No. PCT/US08/064240, dated Nov. 24, 2009, 7 pages.

International Preliminary Report on Patentability and Written Opinion for Application No. PCT/US2006/38978, dated Apr. 16, 2008, 8 pages.

International Preliminary Report on Patentability and Written Opinion for Application No. PCT/US2006/39868, dated Apr. 16, 2008, 6 pages.

International Preliminary Report on Patentability and Written Opinion for Application No. PCT/US2008/072974, dated Feb. 16, 2010, 6 pages.

International Preliminary Report on Patentability and Written Opinion for Application No. PCT/US2009/052473, dated Feb. 1, 2011, 7 pages.

International Preliminary Report on Patentability and Written Opinion for Application No. PCT/US2009/063479, dated May 10, 2011, 11 pages.

International Preliminary Report on Patentability and Written Opinion for Application No. PCT/US2009/063589, dated May 10, 2011, 12 pages.

International Search Report and Written Opinion for Application No. PCT/US2014/047055, dated Oct. 17, 2014, 11 pages.

International Search Report and Written Opinion, dated Mar. 2, 2010, and International Preliminary Report on Patentability, dated May 10, 2011, for Application No. PCT/US2009/063482, 13 pages.

International Search Report and Written Opinion, dated Nov. 2, 2009, and International Preliminary Report on Patentability, dated Feb. 1, 2011, for Application No. PCT/US2009/052466, 12 pages.

International Search Report and Written Opinion, dated May 10, 2010, and International Preliminary Report on Patentability, dated May 10, 2011, for Application No. PCT/US2009/063569, 17 pages.

International Search Report and Written Opinion, dated Feb. 11, 2010, and International Preliminary Report on Patentability, dated May 10, 2011, for Application No. PCT/US2009/063486, 13 pages.

International Search Report for Application No. PCT/US2006/38978, dated Feb. 27, 2007, 3 pages.

International Search Report for Application No. PCT/US2006/39868, dated Nov. 12, 2007, 3 pages.

International Search Report for Application No. PCT/US2009/063479, dated Jun. 11, 2010, 5 pages.

International Search Report for Application No. PCT/US2009/063589, dated Jul. 21, 2010, 7 pages.

International Search Report for Application No. PCT/US2013/027728, dated Jul. 31, 2013, 9 pages.

Merritt R., et al., Wireless Nets Starting to link Medical Gear [online] 2004 [retrieved on Feb. 12, 2007]. Retrieved from the Internet: <http://WWW.embedded.com/news/embeddedindustry/17200577?_requestid=174370>.

"At Issue: venturi vs. peristaltic pumps," Ocular Surgery News U.S. Edition, Sep. 1, 2003, 6 pages.

"4.2.1 Design/Operating principle," Pfeiffer Vacuum, Retrieved from the Internet: (<https://www.pfeiffer-vacuum.com/en/know-how/vacuum-generation/rotar-vane-vacuum-pumps/design-operating-principle/>), printed Oct. 31, 2020.

"An Introduction to Rotary Vane Vacuum Pumps," Gardner Denver GmbH, Retrieved from the Internet: (<https://www.gardnerdenver.com/en-us/knowledge-hub/articles/an-introduction-to-rotary-vane-vacuum-pumps>), printed Oct. 31, 2020.

"Rotary Vane Vacuum Pumps," Becker Pumps Corporation, Retrieved from the Internet: (<https://beckerpumps.com/rotary-vane-oil-less-vacuum-pumps/>), printed Oct. 31, 2020.

* cited by examiner

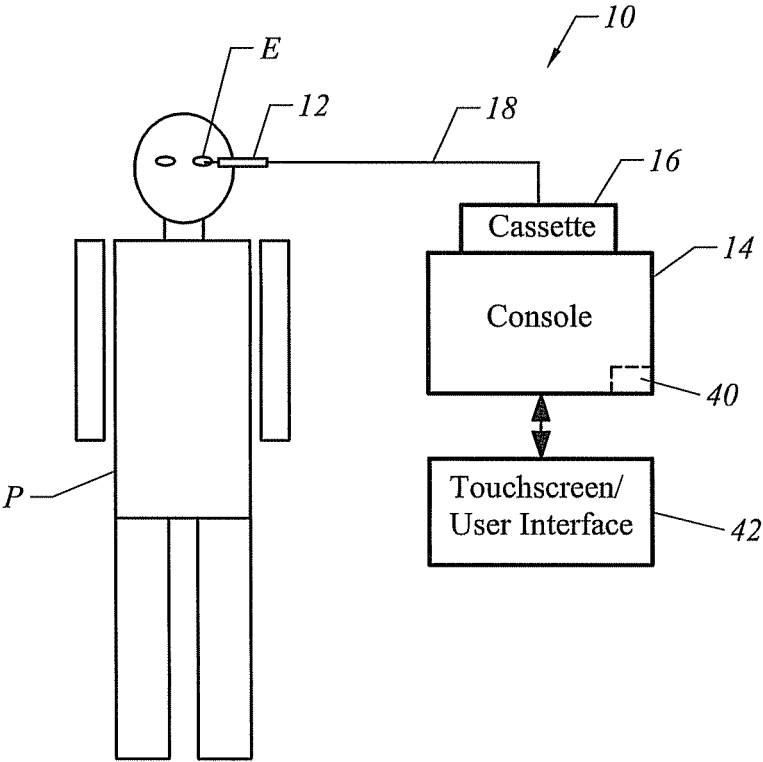

FIG. 1

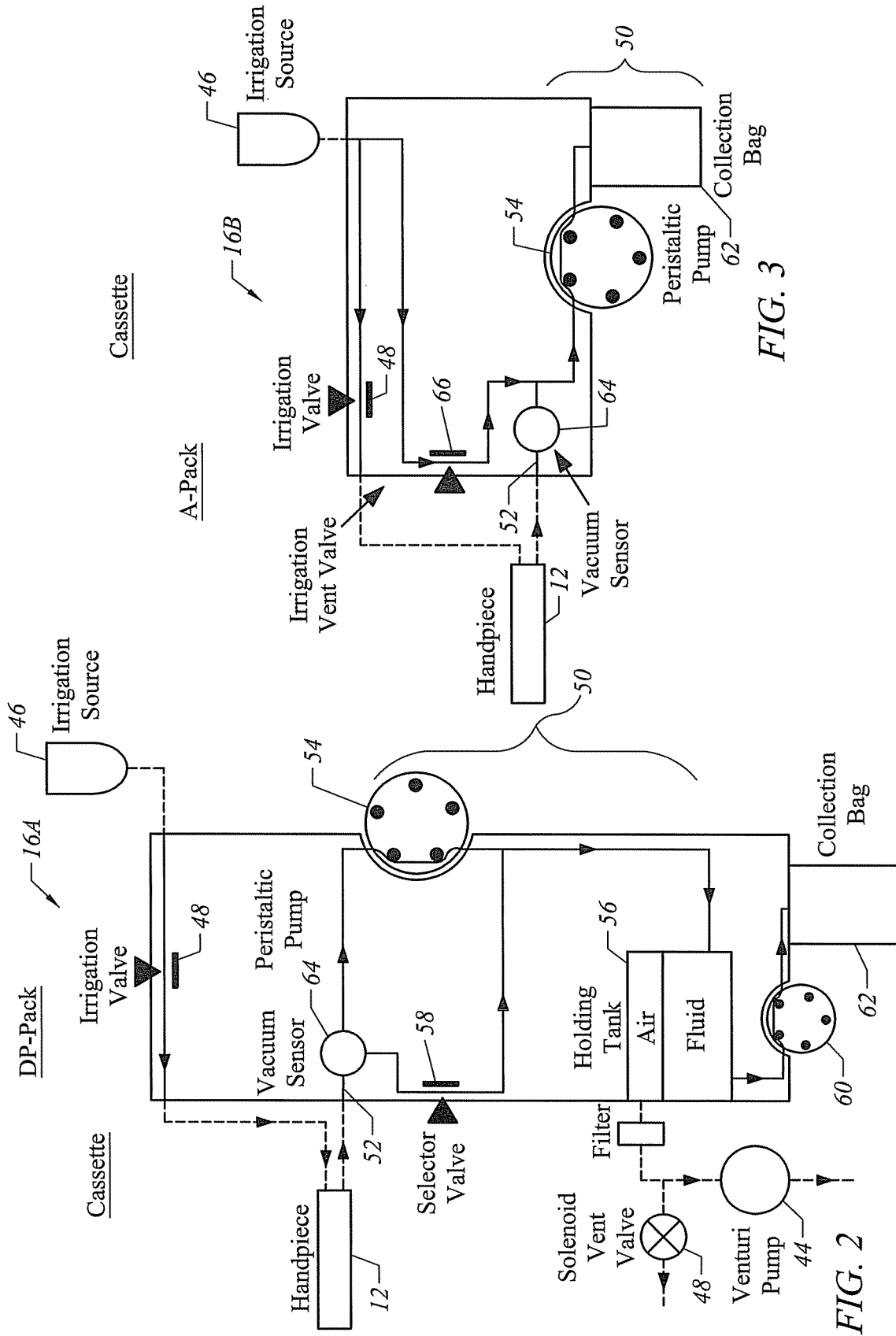

FIG. 2

FIG. 3

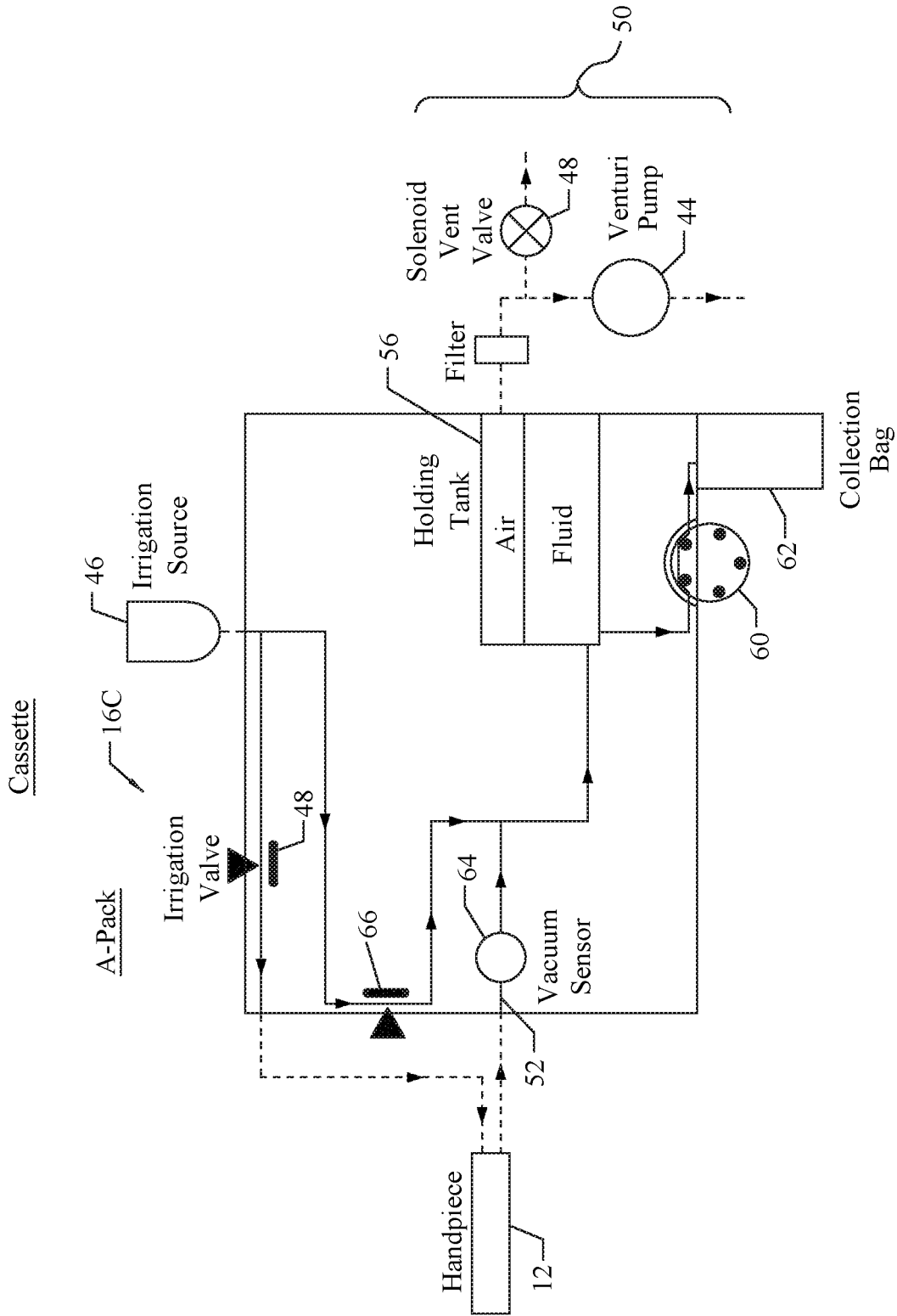

FIG. 3A

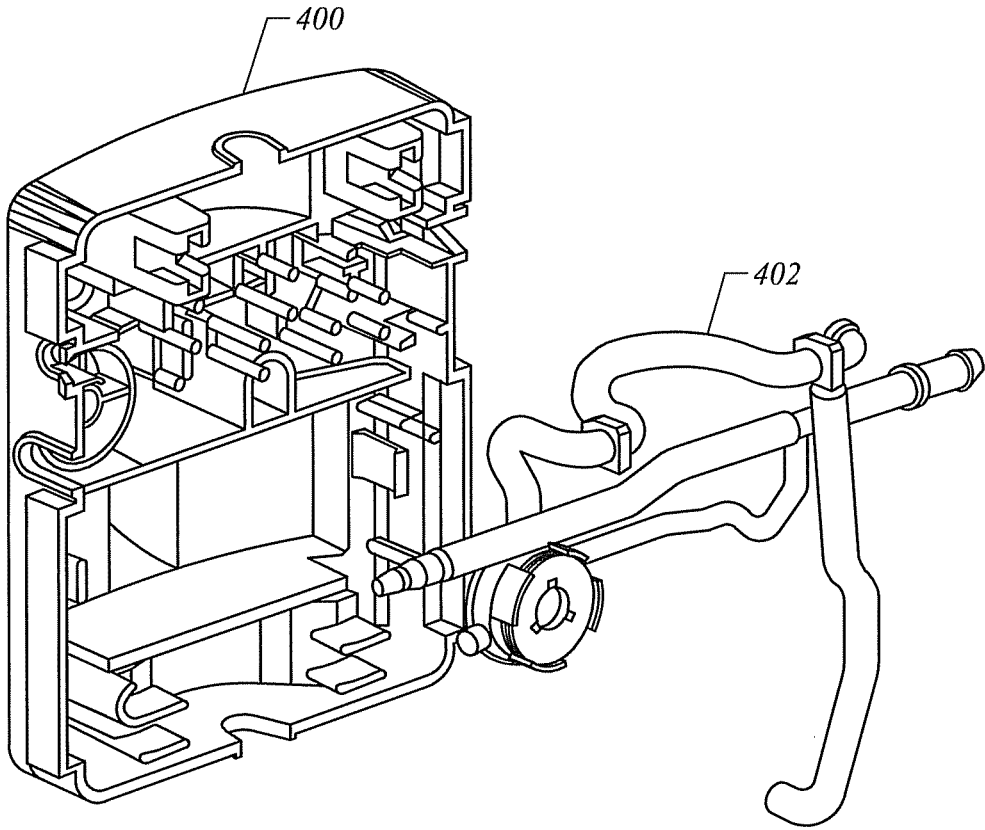

FIG. 4

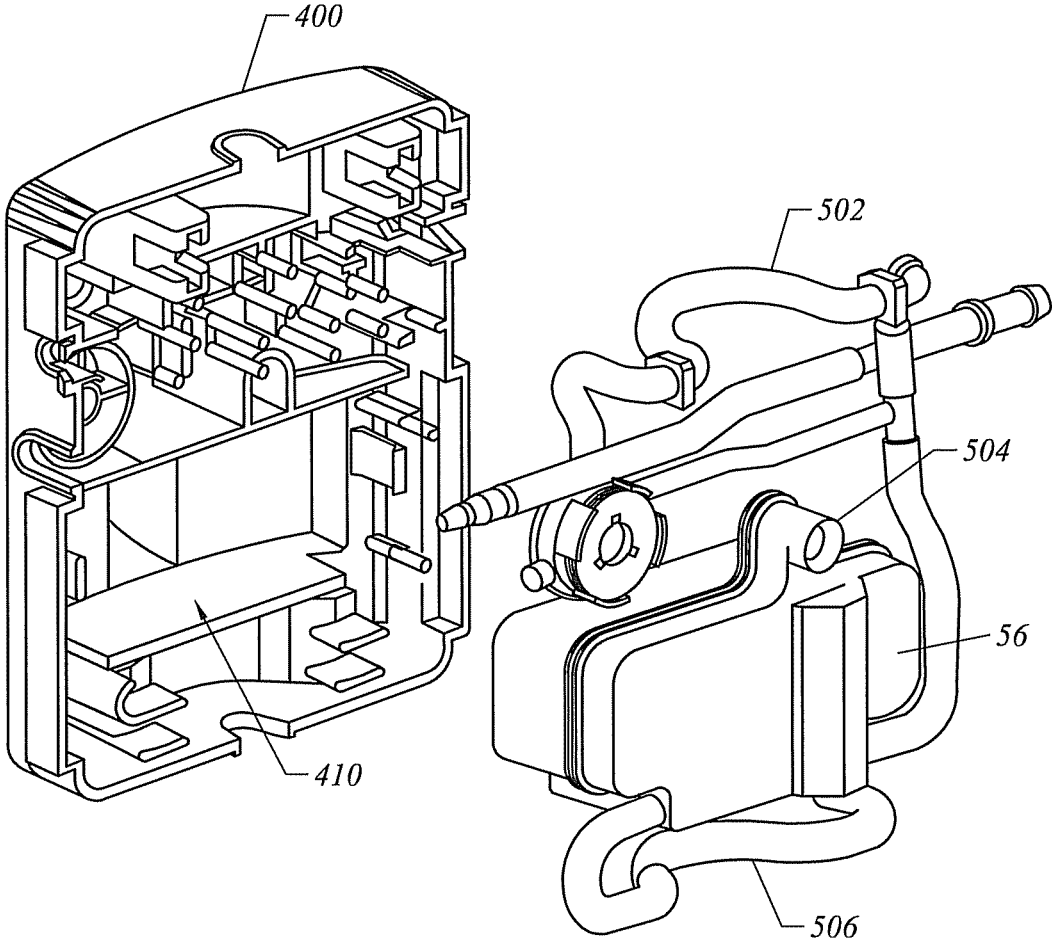

FIG. 5

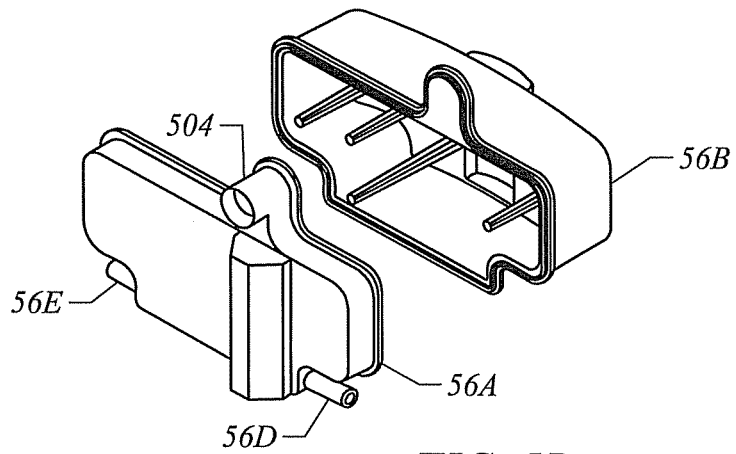

FIG. 5B

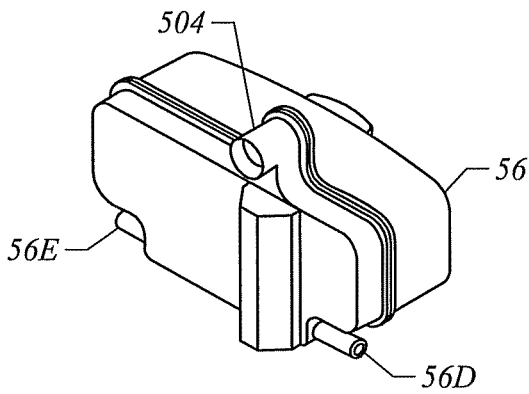

FIG. 5A

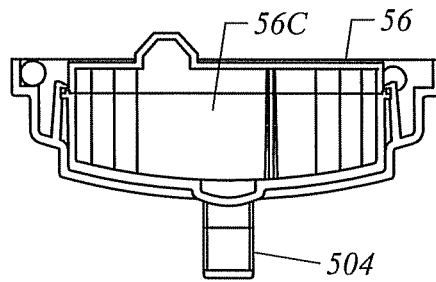

FIG. 5C

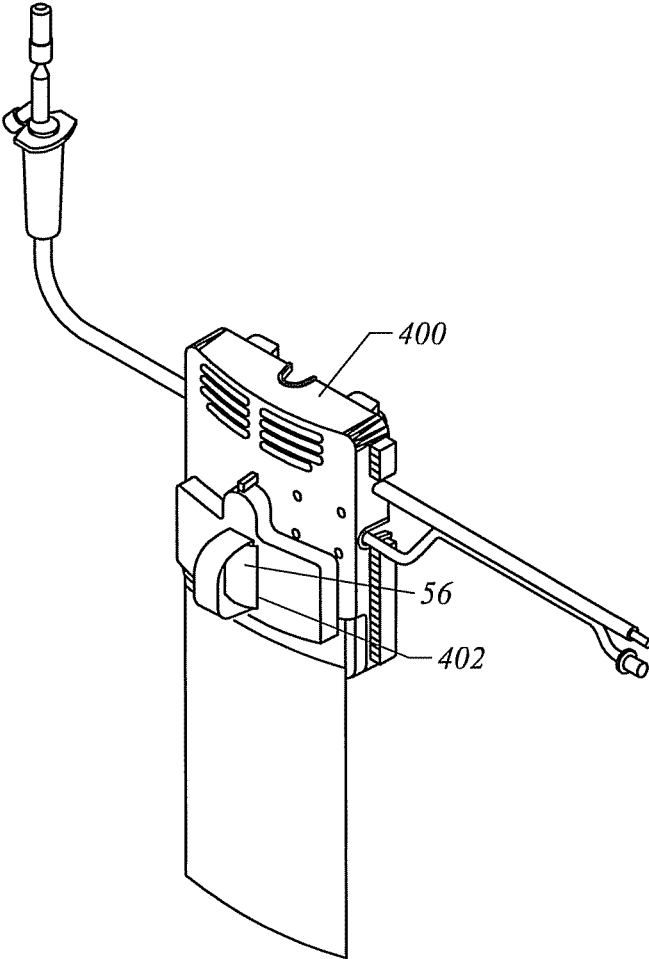

FIG. 6

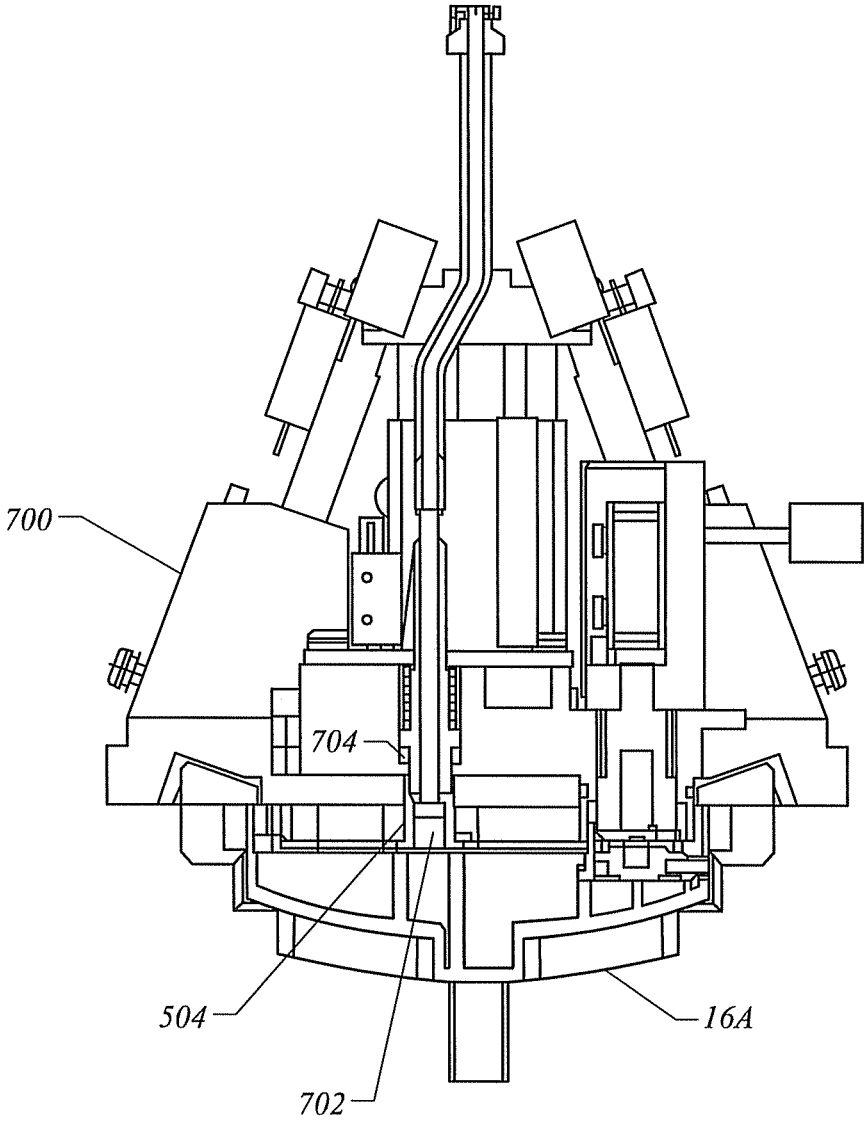

FIG. 7

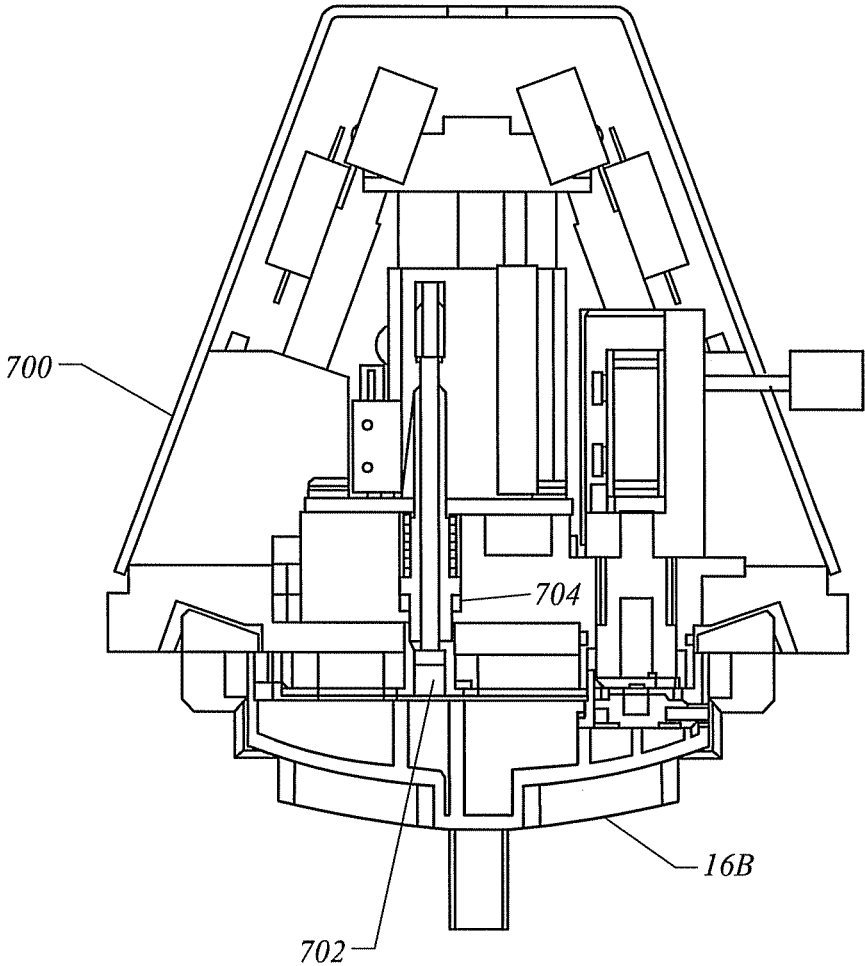

FIG. 7A

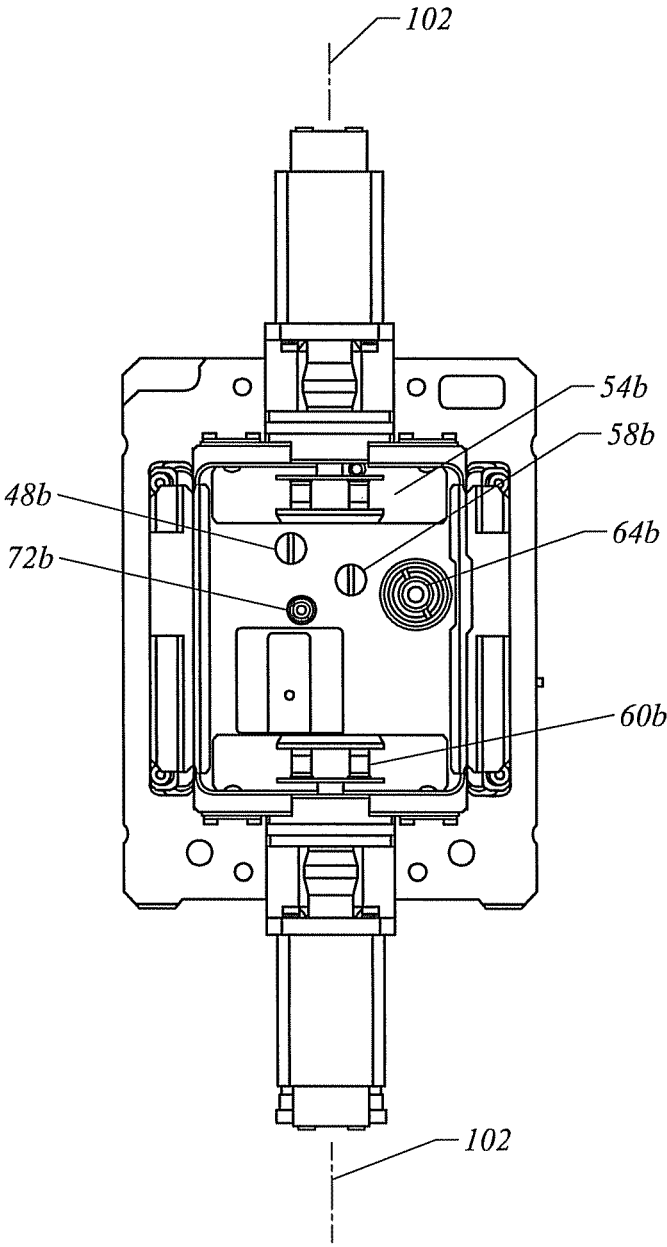

FIG. 8

FLUIDICS CASSETTE FOR OCULAR SURGICAL SYSTEM

BACKGROUND OF THE INVENTION

The present invention is generally related to methods, devices, and systems for controlling surgical fluid flows, particularly during treatment of an eye.

The optical elements of the eye include both a cornea (at the front of the eye) and a lens within the eye. The lens and cornea work together to focus light onto the retina at the back of the eye. The lens also changes in shape, adjusting the focus of the eye to vary between viewing near objects and far objects. The lens is found just behind the pupil, and within a capsular bag. This capsular bag is a thin, relatively delicate structure which separates the eye into anterior and posterior chambers.

With age, clouding of the lens or cataracts are fairly common. Cataracts may form in the hard central nucleus of the lens, in the softer peripheral cortical portion of the lens, or at the back of the lens near the capsular bag.

Cataracts can be treated by the replacement of the cloudy lens with an artificial lens. Phacoemulsification systems often use ultrasound energy to fragment the lens and aspirate the lens material from within the capsular bag. This may allow the capsular bag to be used for positioning of the artificial lens, and maintains the separation between the anterior portion of the eye and the vitreous humour in the posterior chamber of the eye.

During cataract surgery and other therapies of the eye, accurate control over the volume of fluid within the eye is highly beneficial. For example, while ultrasound energy breaks up the lens and allows it to be drawn into a treatment probe with an aspiration flow, a corresponding irrigation flow may be introduced into the eye so that the total volume of fluid in the eye does not change excessively. If the total volume of fluid in the eye is allowed to get too low at any time during the procedure, the eye may collapse and cause significant tissue damage. Similarly, excessive pressure within the eye may strain and injure tissues of the eye.

While a variety of specific fluid transport mechanisms have been used in phacoemulsification and other treatment systems for the eyes, aspiration flow systems can generally be classified in two categories: 1) volumetric-based aspiration flow systems using positive displacement pumps; and 2) vacuum-based aspiration systems using a vacuum source, typically applied to the aspiration flow through an air-liquid interface. These two categories of aspiration flow systems each have unique characteristics that render one more suitable for some procedures than the other, and vice versa.

Among positive displacement aspiration systems, peristaltic pumps (which use rotating rollers that press against a flexible tubing to induce flow) are commonly employed. Such pumps provide accurate control over the flow volume. The pressure of the flow, however, is less accurately controlled and the variations in vacuum may result in the feel or traction of the handpiece varying during a procedure. Peristaltic and other displacement pump systems may also be somewhat slow.

Vacuum-based aspiration systems provide accurate control over the fluid pressure within the eye, particularly when combined with gravity-fed irrigation systems. While vacuum-based systems can result in excessive fluid flows in some circumstances, they provide advantages, for example, when removing a relatively large quantity of the viscous vitreous humour from the posterior chamber of the eye. However, vacuum-based aspiration flow systems connected

to Venturi pumps, rotary vane pumps, and other vacuum sources are subject to pressure surges during occlusion of the treatment probe, and such pressure surges may decrease the surgeon's control over the eye treatment procedure.

Different tissues may be aspirated from the anterior chamber of the eye with the two different types of aspiration flow. For example, vacuum-induced aspiration flow may quickly aspirate tissues at a significant distance from a delicate structure of the eye (such as the capsular bag), while tissues that are closer to the capsular bag are aspirated more methodically using displacement-induced flows.

Conventionally, fluid aspiration systems include a console and a fluidic cassette mounted on the console. The fluidic cassette is changed for each patient and cooperates with the console to provide fluid aspiration. Generally, a single type of cassette is used by a particular console, regardless of whether the procedure will require positive displacement aspiration, vacuum-based aspiration, or both.

In light of the above, it would be advantageous to provide improved devices, systems, and methods for eye surgery.

It would be particularly advantageous if these improvements allowed a console to interchangeably accept different types of cassettes tailored to the type of procedure to be performed.

It would also be particularly advantageous if the console and the cassette automatically communicated to establish the functionalities of the mounted cassette.

It would also be particularly advantageous if the different types of cassettes were modularly produced using common components.

It would also be particularly advantageous if improved means are provided for controlling the volume of the irrigation flow.

BRIEF SUMMARY OF THE INVENTION

The present invention is generally directed to improved methods, devices, and systems for eye surgery. In some embodiments, the invention may provide a console that interchangeably accepts multiple types of fluidic cassettes. The multiple types of cassettes may enable one or both of displacement-based and vacuum-based eye surgery fluid management systems during phacoemulsification, vitreotomy, therapies of the retina, and other treatments that involve penetration into one or more chambers of the eye. The console and the cassettes may automatically communicate to establish the available aspiration modes of the mounted cassette and activate the appropriate mechanisms to enable functionality of the cassettes. Establishment of an available mode or functionality of the cassettes may be passively provided so that a component and/or function indigenous to the operation of one of the cassettes, but not another, is utilized to provide the mode or functionality of one or both cassettes.

Optionally, both displacement and vacuum pumping components may be included in a first type of cassette, and only positive displacement components may be provided in a second type of cassette. Multiple types of fluidic cassettes may be fabricated using a common frame and have visual indicia that identify the type of cassette to a system user. The multiple types of fluidic cassettes may be interchangeably accepted by the console and may include functional indicators that identify to the console the functionalities of the cassettes. A dual mode cassette that enables both displacement-based and vacuum-based fluid aspiration may provide a further displacement-based pump for draining the holding tank of the vacuum-based aspiration system while the

vacuum system continues operation. The dual mode cassette may include an additional, separably coupled holding tank and may provide venting via a vent valve interposed between the holding tank and the vacuum source. A vacuum sensor may also be provided having three ports for connection to the handpiece, a displacement-based pump, and, alternatively, a vacuum source or an irrigation source.

One aspect of the present invention is directed to an eye treatment system that includes an eye treatment probe, a console having a cassette receptacle, and a cassette received in the receptacle configured to couple the console with the probe. The console and the received cassette may communicate to establish a functionality of the cassette. In related aspects, the console may detect a functional indicator of the received cassette. The functional indicator may comprise an indigenous component of the cassette and/or console, for example, a connecting stem an indigenous holding tank actuates a microswitch or optical switch within the console. The functionality of the cassette may comprise displacement-based aspiration induced by a peristaltic pump formed by engagement of the cassette with the console. The functionality of the cassette may comprise vacuum-based aspiration induced by a Venturi or rotary vane pump in the console.

Another aspect of the present invention is directed to a method for operating a surgical console with an eye treatment cassette. The eye treatment cassette is received in a cassette receptacle of the console. The console and the cassette communicate to establish a functionality of the cassette. Vacuum-based aspiration is enabled when the functionality is detected in the cassette.

Another aspect of the present invention is directed to eye treatment cassettes of multiple types configured to interchangeably couple with the same surgical console. A first type of cassette enables displacement-based aspiration when coupled with the console and a second type of cassette enables both displacement-based aspiration and vacuum-based aspiration when coupled with the console. The second type of cassette comprises a separably coupled holding tank for enabling the vacuum-based aspiration. In related aspects, the second type of cassette may comprise the holding tank separably coupled to a fluid network of the first type of cassette. The holding tank may connect to a vacuum source in the console and to a collection bag. The holding tank may communicate to the console that vacuum-based aspiration is available when the second type of cassette is coupled with the console.

Another aspect of the present invention is directed to a method for manufacturing eye treatment cassettes of multiple types configured to interchangeably couple with the same surgical console. A first type of cassette having a fluid network is made for enabling displacement-based aspiration when coupled with the console. A second type of cassette is made for enabling both displacement-based aspiration and vacuum-based aspiration when coupled with the console by separably coupling a holding tank to the fluid network used for the first type of cassette.

Another aspect of the present invention is directed to an eye treatment cassette that includes a fluid network for aspirating fluids from an eye of a patient, and a vacuum sensor connected to the fluid network for controlling a flow of the aspirated fluids having a first port for connecting to a handpiece and second and third ports. In related aspects, the second port connects to a displacement-based pump and the third port alternatively connects to a vacuum source or an irrigation source.

Another aspect of the present invention is directed to a method for venting a handpiece of an eye treatment cassette. The eye treatment cassette is operated such that a vacuum is induced at the handpiece by a vacuum source communicating with the handpiece. The handpiece is vented by opening a vent valve interposed between the vacuum source and the handpiece.

Another aspect of the present invention is directed to an eye treatment cassette that includes a handpiece configured to aspirate fluids from a patient's eye, a vacuum source communicating with the handpiece, and a vent valve interposed between the vacuum source and the handpiece configured to vent the handpiece when opened.

Another aspect of the present invention is directed to a method for draining aspirated fluids collected in a holding tank of an eye treatment cassette. A vacuum source connected to a handpiece via the holding tank continues to operate while a displacement-based pump connected between the holding tank and a collection bag operates to drain the aspirated fluids into the collection bag.

Another aspect of the present invention is directed to an eye treatment cassette that includes a handpiece configured to aspirate fluids from a patient's eye, a vacuum source communicating with the handpiece, a holding tank interposed between the handpiece and the vacuum source configured to hold the aspirated fluids, and a collection bag connected to the holding tank for collecting the aspirated fluids. A displacement-based pump interposed between the holding tank and the collection bag is configured to operate while the vacuum source continues to aspirate fluids via the handpiece to drain the aspirated fluids into the collection bag.

BRIEF DESCRIPTION OF THE DRAWINGS

FIG. 1 schematically illustrates an eye treatment system in which a cassette couples an eye treatment probe with an eye treatment console, along with a method for use of the system for treating the eye of a patient.

FIG. 2 schematically illustrates a dual mode cassette having a surgical fluid pathway network for use in the system of FIG. 1.

FIG. 3 schematically illustrates a single mode displacement-based aspiration cassette having a surgical fluid pathway network for use in the system of FIG. 1.

FIG. 3A schematically illustrates a single mode vacuum-based aspiration cassette having a surgical fluid pathway network for use in the system of FIG. 1.

FIG. 4 is a perspective view showing a single mode fluid network that is mountable on a common cassette frame.

FIG. 5 is a perspective view showing a dual mode fluid network that is mountable on a common cassette frame.

FIGS. 5(a)-(c) are perspective views of the holding tank of the dual mode fluid network of FIG. 5.

FIG. 6 is a perspective view showing an eye treatment cassette having a visual indication of its functionality.

FIG. 7 is a plan view showing the actuation of a microswitch in the console by a functional indicator of the eye treatment cassette.

FIG. 7(a) is a plan view showing a position of the microswitch in the console when the installed eye treatment cassette does not have a functional indicator.

FIG. 8 is a plan view showing the coupling components of a console configured to receive multiple types of eye treatment cassettes.

DETAILED DESCRIPTION OF THE
INVENTION

The present invention generally provides improved devices, systems, and methods for treating an eye of the patient.

In one embodiment of the present invention, a fluid aspiration system includes a console on which multiple types of interchangeable fluidic cassettes can be mounted. Each type of cassette may include components for enabling one or both of displacement-based and vacuum-based aspiration. The cassette may include a surgical fluid network, and mounting of the cassette to the console allows various network elements of the cassette to interface with corresponding components of the console. The fluid network of the cassette may include resiliently deformable tubing, a pressure sensor, a holding tank or chamber, and the like. The components of the fluid network may change depending on whether the cassette enables displacement-based or vacuum-based aspiration, or both. For example, in order to enable displacement-based aspiration, a cassette body may constrain a segment of the tubing in an arcuate configuration, so that when the cassette is mounted to the console, a peristaltic drive rotor of the console engages the arc segment of tubing. This allows positive displacement pumping of aspiration fluid from the eye, through the probe, and into a waste receptacle. When vacuum-based aspiration is needed, the fluid network of the cassette may include a vacuum chamber drawing on a vacuum source within the console.

Referring to FIG. 1, a system 10 for treating an eye E of a patient P generally includes an eye treatment probe handpiece 12 coupled to a console 14 by a cassette 16 mounted on the console. Handpiece 12 generally includes a handle for manually manipulating and supporting an insertable probe tip. The probe tip has a distal end which is insertable into the eye, with one or more lumens in the probe tip allowing irrigation fluid to flow from the console 14 and/or cassette 16 into the eye. Aspiration fluid may also be withdrawn through a lumen of the probe tip, with the console 14 and cassette 16 generally including a vacuum aspiration source, a positive displacement aspiration pump, or both to help withdraw and control a flow of surgical fluids into and out of eye E. As the surgical fluids may include biological materials that should not be transferred between patients, cassette 16 will often comprise a disposable (or alternatively, sterilizable) structure, with the surgical fluids being transmitted through flexible conduits 18 of the cassette that avoid direct contact in between those fluids and the components of console 14.

When a distal end of the probe tip of handpiece 12 is inserted into an eye E (for example) for removal of a lens of a patient with cataracts, an electrical conductor (not shown) may supply energy from console 14 to an ultrasound transmitter of the handpiece. Alternatively, the handpiece 12 may be configured as an I/A or vitrectomy handpiece. Also, the ultrasonic transmitter may be replaced by other means for emulsifying a lens, such as a high energy laser beam. The ultrasound energy from handpiece 12 helps to fragment the tissue of the lens, which can then be drawn into a port of the tip by aspiration flow. So as to balance the volume of material removed by the aspiration flow, an irrigation flow through handpiece 12 (or a separate probe structure) may also be provided, with both the aspiration and irrigations flows being controlled by console 14.

So as to avoid cross-contamination between patients without incurring excessive expenditures for each procedure, cassette 16 and its flexible conduit 18 may be disposable. Alternatively, the flexible conduit or tubing may be

disposable, with the cassette body and/or other structures of the cassette being sterilizable. Regardless, the disposable components of the cassette are typically configured for use with a single patient, and may not be suitable for sterilization. The cassette will interface with reusable (and often quite expensive) components of console 14, including peristaltic pump rollers, a Venturi pump, rotary vane pump, or other vacuum source, a controller 40, and the like.

Controller 40 may include an embedded microcontroller and/or many of the components of a personal computer, such as a processor, a data bus, a memory, input and/or output devices (including a touch screen user interface 42), and the like. Controller 40 will often include both hardware and software, with the software typically comprising machine readable code or programming instructions for implementing one, some, or all of the methods described herein. The code may be embodied by a tangible media such as a memory, a magnetic recording media, an optical recording media, or the like. Controller 40 may have (or be coupled to) a recording media reader, or the code may be transmitted to controller 40 by a network connection such as an internet, an intranet, an Ethernet™, a wireless network, or the like. Along with programming code, controller 40 may include stored data for implementing the methods described herein, and may generate and/or store data that records perimeters with corresponding to the treatment of one or more patients. Many components of console 14 may be found in or modified from known commercial phacoemulsification systems from Advanced Medical Optics Inc. of Santa Ana, Calif.; Alcon Manufacturing, Ltd. of Ft. Worth, Tex., Bausch and Lomb of Rochester, N.Y., and other suppliers.

Referring now to FIGS. 1 and 2, components of the aspiration and irrigation fluid flow networks of system 10 are described in more detail with respect to a dual mode cassette 16A that enables both displacement-based and/or vacuum-based aspiration modes. FIG. 2 generally highlights the surgical aspiration and irrigation fluid control elements included within the cassette 16A, with the irrigation components often being relatively straightforward. An irrigation source 46 of, and/or controlled by, the console optionally provides irrigation fluid pressure control via an irrigation line 51 by relying at least in part on a gravity pressure head that varies with a height of an irrigation fluid bag or the like. An irrigation on/off pinch valve 48 may generally include a short segment of a flexible conduit of cassette 16A, which can be engaged and actuated by an actuator of the console 14, with a surface of the cassette body often being disposed opposite the actuator to facilitate closure of the conduit lumen. Alternative irrigation flow systems may include positive displacement pumps, alternative fluid pressurization drive systems, fluid pressure or flow modulating valves, and/or the like. In certain embodiments, irrigation fluid is alternatively or additionally provided to a separate handpiece (not shown).

The aspiration flow network 50 generally provides an aspiration flow path 52 that can couple an aspiration port in the tip of handpiece 12 to either a peristaltic pump 54, formed by engagement of the cassette with the console via the cassette receptacle 57, and/or a holding tank 56. Fluid aspirated through the handpiece 12 may be contained in holding tank 56 regardless of whether the aspiration flow is induced by peristaltic pump 54 or the vacuum applied to the holding tank 56. When valve 58 is closed and peristaltic pump 54 is in operation, pumping of the aspiration flow may generally be directed by the peristaltic pump 54, independent of the pressure in the holding tank 56. Conversely, when peristaltic pump 54 is off, flow through the peristaltic

pump may be halted by pinching of the elastomeric tubing arc of the peristaltic pump by one or more of the individual rollers of the peristaltic pump rotor. Hence, any aspiration fluid drawn into the aspiration network when peristaltic pump 54 is off will typically be effected by opening of a selector control valve 58 so that the aspiration port of the probe is in fluid communication with the holding tank. Regardless, the pressure within tank 56 may be maintained at a controlled vacuum level, often at a fixed vacuum level, by a vacuum system 44 of the console. The vacuum system 44 may comprise a Venturi pump, a rotary vane pump, a vacuum source, or the like. Aspiration flow fluid that drains into holding tank 56 may be removed by a peristaltic drain pump 60 and directed to a disposal fluid collection bag 62. Vacuum pressure at the surgical handpiece may be maintained within a desired range through control of the fluid level in the holding tank. In particular, peristaltic drain pump 60 enables the holding tank 56 to be drained while vacuum-based aspiration continues using vacuum system 44.

In more detail, the operation of aspiration flow network 50 can be understood by first considering the flow when valve 58 is closed. In this mode, peristaltic pump 54 draws fluid directly from handpiece 12, with a positive displacement peristaltic pump flow rate being controlled by the system controller 40 (see FIG. 1). To determine the appropriate flow rate, the level of vacuum within the aspiration flow network may be identified in part with reference to a vacuum sensor 64 with three ports disposed along the aspiration flow network 50 between peristaltic pump 54, handpiece 12, and selector valve 58. This allows the system to detect and adjust for temporary occlusions of the handpiece and the like. Venting or reflux of the handpiece 12 in this state may be achieved by reversing the rotation of peristaltic pump 54 or by opening selector valve 58 to equalize fluid pressures. Selector valve 58 may be configured as a variable restrictor to regulate the amount of fluid that is vented from the high pressure side of peristaltic pump 54 to the low pressure side. In this mode, while the aspiration material flows through holding tank 56 and eventually into collection bag 62, the holding tank pressure may have little or no effect on the flow rate.

When peristaltic pump 54 is not in operation, rotation of the peristaltic pump is may be inhibited and the rotors of the peristaltic pump generally pinch the arcuate resilient tubing of the probe so as to block aspiration flow. Material may then be drawn into the aspiration port of handpiece 12 by opening selector valve 58 and engagement or operation of the vacuum system 44. When valve 58 is open, the aspiration port draws fluid therein based on the pressure differential between holding tank 56 and the chamber of the eye in which the fluid port is disposed, with the pressure differential being reduced by the total pressure loss of the aspiration flow along the aspiration path between the tank and port. In this mode, venting or reflux of the handpiece 12 may be accomplished by opening the solenoid vent valve 48', which pressurizes the holding tank 56 to increase the tank pressure and push fluid back towards (i.e., "vents") the handpiece 12. In some embodiments, the vent valve 48' may be used to increase the pressure inside the tank 56 to at or near atmospheric pressure. Alternatively, venting of the handpiece may be accomplished in this mode by closing selector valve 58, and by rotation peristaltic pump 54 in reverse (e.g., clockwise in FIG. 2). Accordingly, aspiration network 50 of the dual mode cassette 16A allows system 10 to operate in either peristaltic or vacuum-based pumping modes and to incorporate three different venting modes. In some embodiments, an additional valve is added to the cassette 16A that

may be used to fluidly couple the irrigation line 51 to the aspiration flow network 50, thus providing an addition option for venting or refluxing the handpiece 12.

When only displacement-based pumping will be used for a particular procedure, an alternative cassette may be employed in the console 14, with the alternative cassette lacking a holding tank 56, selector valve 58, and the like. Referring now to FIGS. 1 and 3, components of a single mode cassette 16B are described, the single mode cassette enabling only the displacement-based aspiration mode. Within the single mode cassette, peristaltic pump 54 draws fluid directly from handpiece 12, with a positive displacement peristaltic pump flow rate being controlled by the system controller 40 (see FIG. 1). To determine the appropriate flow rate, the level of vacuum within the aspiration flow network may be identified in part with reference to a vacuum sensor 64 with three ports disposed along the aspiration flow network 50 between peristaltic pump 54, handpiece 12, and irrigation vent valve 66. The aspiration material flows directly into collection bag 62. Alternatively, a single mode cassette may also be provided that only enables vacuum-based aspiration, as illustrated in FIG. 3A.

As a dual mode cassette may be somewhat more complex, a single mode cassette may be both simpler and less expensive. Therefore, the present invention may avoid complexity and provide cost savings by enabling the use of a less expensive single mode cassette when only a single aspiration mode is needed during a procedure on a particular patient.

In one embodiment of the present invention, fluid networks specialized for each different type of cassette (e.g., single mode or dual mode) can be interchangeably mounted within a common cassette frame. With reference to FIGS. 4 and 5, a single mode fluid network 402 (displacement mode only) and a dual mode fluid network 502 are both mountable on a common cassette frame 400. The common cassette frame 400 includes channels and receptacles for receiving and securing the fluid networks' tubing, valves, tanks, etc. The cassette frame and the fluid networks are cooperatively designed such that the cassette frame is capable of receiving multiple, differently configured fluid networks. By utilizing a common frame for multiple types of cassettes, the present invention may eliminate or reduce the excess production and inventory costs related to having multiple types of cassettes. The common frame 400 also makes it easier for the console to accept multiple types of cassettes, whereby at least the physical dimensions of the cassette frame remain the same amongst different types of cassettes.

As shown in FIG. 5, fluid network 502, which is a dual mode fluid network that enables vacuum-based aspiration, includes a holding tank 56 that is not present in fluid network 402. Tank 56 may be connected to a vacuum pump (e.g., a Venturi pump) located in the surgical console and may provide vacuum-based aspiration to the handpiece when selector valve 58 (FIG. 2) connects the handpiece to the vacuum generated in tank 56. As illustrated by FIG. 5, common cassette frame 400 may include a receptacle 410 configured to receive holding tank 56. The holding tank may also receive aspirated fluids before the fluid is drained to the collection bag.

FIGS. 5(a)-(c) illustrate an exemplary holding tank 56 from dual mode fluid network 502. In particular, tank 56 may be formed from two clear plastic pieces 56A and 56B to define a hollow interior 56C therein. The tank may include a connecting stem 504 that communicates with hollow interior 56C and connects the tank to an exterior vacuum source (e.g., a vacuum pump located in the console). Tank

56 may also include connectors **56D** and **56E**, which allow the tank to be connected to the fluid network via tubing. For example, connector **56D** may connect the holding tank (via the selector valve) to the handpiece **12** (FIG. 2). Vacuum suction may be provided to the handpiece through connector **56D** and aspirated fluids may be received into the holding tank via this connector. Connector **56E** may connect the holding tank to the collection bag **62** (FIG. 2). Tubing that leads from connector **56E** to the collection bag may include an arcuate section **506** (FIG. 5) that enables displacement-based evacuation of the fluids in the holding tank when coupled with a peristaltic pump (e.g., pump **60** of FIG. 2). Accordingly, the holding tank **56** may be connected to the fluid network when vacuum-based aspiration is desired. When not needed, the separable holding tank **56** may be removed from the fluid network to reduce the cost of the cassette.

The console and the cassette may communicate to establish the functionality of the mounted cassette (i.e., the modes of aspiration enabled by the cassette). In one approach, a cassette may include a functional indicator that is detected by the console and which identifies the available functionalities of the installed cassette. For example, with reference to FIG. 5, fluid network **502** for a dual mode cassette includes the holding tank **56**. Holding tank **56** includes a connecting stem **504**, which connects the holding tank with a vacuum pump (not shown) located in the surgical console on which the dual mode cassette **16A** is mounted. With reference to FIG. 7, engagement of the connecting stem **504** with a sealing nipple **702** of the surgical console **700** may actuate a microswitch **704** and indicate to the console that vacuum-enabled cassette **16A** has been installed. In response, the console **700** may activate its vacuum pump and other necessary mechanism in preparation for vacuum-based aspiration. Thus, indigenous or native element of the dual mode cassette **16A**, that is, the holding tank **56** with the connecting stem **504**, are utilized to communicate to the console to establish a functionality of the mounted cassette.

By contrast, as illustrated by FIG. 7(a), the cassette **16B** does not contain a holding tank **56** with a connecting stem **504**, indigenous to the operation of cassette **16A** within the system. Thus, when cassette **16B** is installed on console **700**, microswitch **704** is not triggered because no holding tank is native to the cassette **16B**. Accordingly, the console will be informed that no vacuum-based aspiration is available with the mounted cassette. Therefore, utilizing a functional indicator (absence of a holding tank **56** with a connecting stem **504**), the surgical console may be informed upon mounting of the cassette that vacuum-based aspiration is available with the mounted cassette. In an embodiment where only two different cassettes are available (i.e., a displacement mode cassette and a dual mode cassette with vacuum aspiration), the console may confirm by presence of the holding tank which of the two types of cassettes has been mounted on the console. In some embodiments the use of an indigenous element or function may increase the reliability of accurately communicating correct mode or functionality information, since the communication is based on an actual cassette capability and not on, for example, on a modification to the cassette frame or a component of the cassette which correlates with a function that may or may not actually be present. An example of the later might include the use of a tab that is left or removed from the cassette body, depending of capability of the cassette to support vacuum pump operation. In this case, for example due to a human

error, the tab might be incorrectly set to communication support of vacuum pump operation, when in fact no such support exist.

It should be understood that the foregoing example of the use of an indigenous element of the cassette is illustrative only. Alternative methods and structures may also be used. For example, a non-mechanical method may be used where the cassette is labeled with a bar code containing functional information that is automatically scanned by the console. Regardless of the specific method used, the console and cassette of the present invention communicate to establish the functionalities available with the installed cassette, and the console prepares itself accordingly.

The exemplary cassette may possess a visual indicator of its functionality (i.e., the aspiration modes enabled by the cassette). For example, with reference to FIG. 6, cassette frame **400** may include a window **404** through which the holding tank **56** of a dual mode fluid network may be seen. Therefore, if a holding tank is visible through window **402**, a system operator will be informed that vacuum-based aspiration is available with the mounted cassette. In an embodiment where only two different cassettes are available (i.e., a displacement mode cassette and a dual mode cassette with vacuum aspiration), an operator may also visually confirm which of the two types of cassettes has been mounted on the console. Other visual indicia, such as alphanumeric codes or color-coded patches, may also be used to indicate the functionality of the cassette. In some embodiments, a clear cassette may be provided through which the presence of a holding tank may be visually confirmed and indicate the functionality of the cassette.

FIG. 8 illustrates a surgical console of the present invention which interchangeably receives multiple types of fluidic cassettes that enable one or both of displacement-based and vacuum-based aspiration modes. Engagement between the cassette and the cassette receptacle **57** of console **14** can be understood with reference to FIGS. 2, 3, and 8. In particular, aspiration drive rotor **54b** rotates about axis **102** and drives peristaltic pump **54** in either cassette **16A** or **16B**. Pressure receiver **64b** and valve actuator **48b** respectively couple with vacuum sensor **64** and irrigation valve **48** mounted in either type of cassette. When dual mode cassette **16A** is mounted on the console, drain drive rotor **60b** rotates about axis **102** to drive peristaltic drain pump **60** in the cassette. Valve actuator **58b** is coupled with switching valve **58** of cassette **16A**. Vacuum coupler **72b** couples with holding tank **56** of cassette **16A**. And, as previously described with respect to FIGS. 5 and 7, connecting stem **504** of holding tank **56** actuates a microswitch **704** within coupler **72b** and indicates to the console that vacuum aspiration is available with the mounted cassette. It should be understood that the console may use other methods to actively detect or passively receive information from the mounted cassette regarding its functionality.

While the exemplary embodiments have been described in some detail for clarity of understanding and by way of example, a variety of changes, modifications, and adaptations will be obvious to those of skill in the art. Hence, the scope of the present invention is limited solely by the appended claims.

What is claimed is:

1. An eye treatment system comprising:

an eye treatment probe;

a console having a cassette receptacle, wherein the cassette receptacle is configured to interchangeably receive a first cassette type configured to facilitate a positive displacement aspiration functionality, a second

11

cassette type configured to facilitate vacuum-based aspiration functionality, and a third cassette type configured to facilitate both the positive displacement aspiration functionality and the vacuum-based aspiration functionality, the console comprising a driver rotor to enable the positive displacement aspiration functionality and a vacuum source configured to induce the vacuum-based aspiration functionality; and

a cassette selected from a group consisting of the first cassette type, the second cassette type, and the third cassette type, wherein the cassette is configured to be received in the receptacle and to couple the console with the eye treatment probe forming at least one fluid network, and wherein the console and the received cassette are configured to communicate a functionality of the received cassette based on the cassette type by the console detecting a functional indicator of the received cassette, and

wherein the console is configured to activate the vacuum source configured to induce the vacuum-based aspiration functionality or the drive rotor to enable the positive displacement aspiration functionality in the at least one fluid network as indicated by the detected functional indicator.

2. The eye treatment system of claim 1, wherein the functional indicator of the received cassette comprises a holding tank having a connecting stem that actuates a microswitch within the console.

3. The eye treatment system of claim 1, wherein the positive displacement aspiration functionality comprises aspiration induced by a peristaltic pump formed by engagement of the received cassette with the drive rotor of the console.

4. The eye treatment system of claim 1, wherein the vacuum source configured to induce the vacuum-based aspiration functionality is a Venturi pump or a rotary vane pump.

5. An eye treatment system comprising:
an eye treatment probe;
a console comprising a cassette receptacle, a driver rotor to enable a positive displacement aspiration functionality and a vacuum source configured to induce a vacuum-based aspiration functionality; and
a cassette selected from a group consisting of a first cassette type, a second cassette type, and a third cassette type, the first cassette type configured to facilitate the positive displacement aspiration functionality, the second cassette type configured to facilitate the vacuum-based aspiration functionality, and the third cassette type configured to facilitate both the positive displacement aspiration functionality and the vacuum-based aspiration functionality, wherein each cassette type is configured to fluidly couple the console with the eye treatment probe,
wherein the cassette receptacle is configured to receive the first cassette type, the second cassette type, and the third cassette type, and wherein each received cassette type is configured to communicate its functionality to the console, by the console detecting an indigenous element of the received cassette, and the console is configured to activate at least one of the vacuum source configured to induce vacuum-based aspiration or the

12

drive rotor to enable the positive displacement aspiration functionality based on the functionality communicated.

6. The eye treatment system of claim 5, wherein the indigenous element comprises a functional indicator of the received cassette.

7. The eye treatment system of claim 5, wherein the indigenous element comprises a holding tank having a connecting stem that actuates a micro switch within the console.

8. The eye treatment system of claim 5, wherein the positive displacement aspiration functionality comprises aspiration induced by a peristaltic pump formed by engagement of the received cassette with the drive rotor of the console.

9. The eye treatment system of claim 5, wherein the vacuum source configured to induce the vacuum-based aspiration functionality comprises a Venturi pump or a rotary vane pump.

10. An eye treatment system comprising:
a console comprising a cassette receptacle, a driver rotor to enable a positive displacement aspiration functionality and a vacuum source configured to induce a vacuum-based aspiration functionality;
an eye treatment probe configured to be fluidly connected to the console via a cassette disposed within the cassette receptacle, the cassette selected from a group consisting of a first cassette type, a second cassette type, and a third cassette type, wherein the cassette receptacle is configured to interchangeably receive the first cassette type, the second cassette type and the third cassette type, the first cassette type configured to facilitate the positive displacement aspiration functionality, the second cassette type configured to facilitate the vacuum-based aspiration functionality, and the third cassette type configured to facilitate the positive displacement aspiration functionality and the vacuum-based aspiration functionality, and wherein the console and each received cassette type are configured to communicate to establish the functionality of each received cassette type by the console detecting a functional indicator in each received cassette type, wherein the console is configured to activate at least one of the vacuum source configured to induce the vacuum-based aspiration functionality or the drive rotor to enable the positive displacement aspiration functionality, based on the indicated functionality to the received cassette commensurate with the detected functional indicator.

11. The eye treatment system of claim 10, wherein the functional indicator comprises a holding tank having a connecting stem, that actuates a micro switch within the console.

12. The eye treatment system of claim 10, wherein the positive displacement aspiration functionality is induced by a peristaltic pump formed by engagement of the received cassette with the drive rotor of the console.

13. The eye treatment system of claim 10, wherein the vacuum source configured to induce the vacuum-based aspiration functionality comprises a Venturi pump or a rotary vane pump.

* * * * *