

(19) World Intellectual Property Organization
International Bureau



(43) International Publication Date
27 December 2007 (27.12.2007)

PCT

(10) International Publication Number
WO 2007/149254 A2

(51) International Patent Classification:
A47L 9/16 (2006.01) B04C 5/185 (2006.01)

(74) Agent: MOLDOVANYI, Jay, F.; Fay Sharpe LLP, 1100 Superior Avenue, 7th Floor, Cleveland, OH 44114 (US).

(21) International Application Number:
PCT/US2007/013678

(81) Designated States (unless otherwise indicated, for every kind of national protection available): AE, AG, AL, AM, AT, AU, AZ, BA, BB, BG, BH, BR, BW, BY, BZ, CA, CH, CN, CO, CR, CU, CZ, DE, DK, DM, DO, DZ, EC, EE, EG, ES, FI, GB, GD, GE, GH, GM, GT, HN, HR, HU, ID, IL, IN, IS, JP, KE, KG, KM, KN, KP, KR, KZ, LA, LC, LK, LR, LS, LT, LU, LY, MA, MD, ME, MG, MK, MN, MW, MX, MY, MZ, NA, NG, NI, NO, NZ, OM, PG, PH, PL, PT, RO, RS, RU, SC, SD, SE, SG, SK, SL, SM, SV, SY, TJ, TM, TN, TR, TT, TZ, UA, UG, US, UZ, VC, VN, ZA, ZM, ZW.

(22) International Filing Date: 11 June 2007 (11.06.2007)

(25) Filing Language: English

(26) Publication Language: English

(30) Priority Data:
60/814,661 16 June 2006 (16.06.2006) US
60/818,149 30 June 2006 (30.06.2006) US
60/837,988 16 August 2006 (16.08.2006) US
11/607,362 1 December 2006 (01.12.2006) US

(84) Designated States (unless otherwise indicated, for every kind of regional protection available): ARIPO (BW, GH, GM, KE, LS, MW, MZ, NA, SD, SL, SZ, TZ, UG, ZM, ZW), Eurasian (AM, AZ, BY, KG, KZ, MD, RU, TJ, TM), European (AT, BE, BG, CH, CY, CZ, DE, DK, EE, ES, FI, FR, GB, GR, HU, IE, IS, IT, LT, LU, LV, MC, MT, NL, PL, PT, RO, SE, SI, SK, TR), OAPI (BF, BJ, CF, CG, CI, CM, GA, GN, GQ, GW, ML, MR, NE, SN, TD, TG).

(71) Applicant (for all designated States except US): ROYAL APPLIANCE MFG. CO. [US/US]; 7005 Cochran Road, Glenwillow, OH 44139 (US).

(72) Inventors; and

(75) Inventors/Applicants (for US only): MAKAROV, Sergey, V. [US/US]; 33273 Cottesmore Pl., Solon, OH 44139 (US). PALIOBEIS, Steven, J. [US/US]; 631 Lanark Lane, Painesville, OH 44077 (US). LOEBIG, Jeffrey, C. [US/US]; 8988 Birchwood Drive, Twinsburg, OH 44087 (US).

Published:

— without international search report and to be republished upon receipt of that report

For two-letter codes and other abbreviations, refer to the "Guidance Notes on Codes and Abbreviations" appearing at the beginning of each regular issue of the PCT Gazette.

(54) Title: SEPARATELY OPENING DUST CONTAINERS

(57) Abstract: The present invention relates to a home cleaning appliance including a housing including a nozzle having a main suction opening and a brush. An air stream suction source, mounted to the housing, includes a suction airstream inlet and a suction airstream outlet. The suction source selectively establishes and maintains a suction airstream from the nozzle main suction opening to the airstream outlet. A cyclone main body is mounted to the housing and is in communication with the nozzle main suction opening. The cyclone main body includes an upstream, first, cyclonic separator for separating dust from dust-laden air, and at least one downstream, second, cyclonic separator for separating remaining dust particles from the air. A dirt cup is connected to the cyclone main body. The dirt cup includes a first particle collector communicating with the first separator for collecting dust particles separated by the first separator, and a second particle collector communicating with the at least one second separator for collecting dust particles separated by the at least one second separator. The first particle collector and the second particle collector are configured to empty independently of each other.

WO 2007/149254 A2

SEPARATELY OPENING DUST CONTAINERS

Cross Reference to Related Applications

[0001] This application claims priority from U.S. Provisional Patent Application Serial No. 60/814,661 filed June 16, 2006; U.S. Provisional Patent Application Serial No. 60/818,149 filed June 30, 2006; and U.S. Provisional Patent Application Serial No. 60/837,988 filed August 16, 2006. Each provisional patent application is expressly incorporated herein by reference, in its entirety.

Background of the Invention

[0002] The present invention relates to vacuum cleaners. More particularly, the present invention relates to dual stage cyclonic vacuum cleaners used for suctioning dirt and debris from carpets and floors. Such vacuum cleaners can be upright, canister, hand-held or stationary, built into a house. Moreover, cyclonic designs have also been used on carpet extractors and "shop" type vacuum cleaners.

[0003] Upright vacuum cleaners are well known in the art. The two major types of traditional vacuum cleaners are a soft bag vacuum cleaner and a hard shell vacuum cleaner. In the hard shell vacuum cleaner, a vacuum source generates the suction required to pull dirt from the carpet or floor being vacuumed through a suction opening and into a filter bag or a dust cup housed within the hard shell upper portion of the vacuum cleaner. After multiple uses of the vacuum cleaner, the filter bag must be replaced or the dust cup emptied.

[0004] To avoid the need for vacuum filter bags, and the associated expense and inconvenience of replacing the filter bag, another type of upright vacuum cleaner utilizes cyclonic air flow and perhaps one or more filters, rather than a replaceable filter bag, to separate the dirt and other particulates from the suction air stream. If filters are used, they would need infrequent replacement.

[0005] While some prior art cyclonic air flow vacuum cleaner designs and constructions are acceptable, the need exists for continued improvements and alternative designs for such vacuum cleaners. For example, it would be desirable to simplify assembly and improve filtering and dirt removal.

[0006] Accordingly, the present invention provides a new and improved upright vacuum cleaner having a dual stage cyclonic air flow design which overcomes certain difficulties with the prior art designs while providing better and more advantageous overall results.

Brief Description

[0007] In accordance with one aspect of the present invention, a home cleaning appliance comprises a housing comprising a nozzle including a main suction opening and a brush. An air stream suction source, mounted to the housing, includes a suction airstream inlet and a suction airstream outlet. The suction source selectively establishes and maintains a suction airstream from the nozzle main suction opening to the airstream outlet. A cyclone main body is mounted to the housing and is in communication with the nozzle main suction opening. The cyclone main body includes an upstream, first, cyclonic separator for separating dust from dust-laden air, and at least one downstream, second, cyclonic separator for separating remaining dust particles from the air. A dirt cup is connected to the cyclone main body. The dirt cup includes a first particle collector communicating with the first separator for collecting dust particles separated by the first separator, and a second particle collector communicating with the at least one second separator for collecting dust particles separated by the at least one second separator. The first particle collector and the second particle collector are configured to empty independently of each other.

[0008] In accordance with another aspect of the present invention, an upright vacuum cleaner comprises a nozzle base having a main suction opening and a housing pivotally mounted on the nozzle base. An airstream suction source is mounted to one of the housing and the nozzle base for selectively establishing and maintaining a suction airstream from the nozzle main suction opening to an exhaust outlet of the suction source. A cyclone main body is mounted to the housing. The cyclone main body comprises a first upstream cyclone part for separating coarse dust from dust-laden air, and a second downstream cyclone part for separating remaining dust particles from the air. A first particle collector is mounted to the housing and communicates with the first cyclone part for collecting a first portion of dust particles. The first particle collector includes a first closure

member operably secured to the first particle collector for emptying the first particle collector. A separate second particle collector is mounted to the housing and communicates with the second cyclone part for collecting a second portion of dust particles. The second particle collector includes a second closure member operably secured to the second particle collector for independent emptying of the second particle collector.

[0009] In accordance with yet another aspect of the present invention, a household vacuum cleaner comprises a first housing section including a suction opening, and at least one wheel to allow the first housing section to roll over a subjacent surface. A second housing section is connected to the first housing section. An airstream suction source is mounted to one of the first and second housing sections. A cyclone main body is mounted to the second housing section. The cyclone main body includes an upstream separator stage including an upstream cyclone, and a downstream separator stage including a plurality of downstream cyclones. The airstream suction source communicates with the first housing section suction opening via the cyclone main body so that an airstream flows from the suction opening through the upstream cyclone, the plurality of downstream cyclones and to an inlet of the airstream suction source. A first particle collector communicates with the upstream cyclone. A second particle collector communicates with the plurality of downstream cyclones. The second particle collector is configured to empty independently of the first particle collector.

[0010] In accordance with still yet another aspect of the present invention, a home vacuum cleaner includes a housing in fluid communication with a main suction opening and a brush roll rotatably mounted in the main suction opening. An airstream suction source is mounted to the housing for selectively establishing and maintaining a suction airstream flowing from the main suction opening to an exhaust outlet of the suction source. A dirt collector is mounted to the housing. The dirt collector comprises a first upstream cyclone part for separating dust from dust-laden air, a second downstream cyclone part for separating remaining dust particles from the air. A first particle collector communicates with the first cyclone part for collecting dust particles, and a second particle collector communicates with the second cyclone part for collecting dust particles. The first particle

separator generally surrounds the second particle collector. The first particle collector and the second particle collector are configured to independently store and separately empty dirt and dust particles separated by the respective first and second cyclone parts.

[0011] Still other aspects of the invention will become apparent from a reading and understanding of the detailed description of the several embodiments described hereinbelow.

Brief Description of the Drawings

[0012] The present invention may take physical form in certain parts and arrangements of parts, several embodiments of which will be described in detail in this specification and illustrated in the accompanying drawings which form a part of the disclosure.

[0013] FIGURE 1 is a front perspective view illustrating a dual stage cyclone vacuum cleaner in accordance with a first embodiment of the present invention.

[0014] FIGURE 2 is a rear perspective view of the dual stage cyclone vacuum cleaner of FIGURE 1.

[0015] FIGURE 3 is a rear perspective view of an assembled dust collector for the dual stage vacuum cleaner of FIGURE 1.

[0016] FIGURE 4 is a front perspective view of the assembled dust collector for the dual stage vacuum cleaner of FIGURE 1.

[0017] FIGURE 5 is an enlarged exploded perspective view of the dust collector of the dual stage vacuum cleaner of FIGURE 1, together with associated components thereof.

[0018] FIGURE 6 is an enlarged cross-sectional view of the dust collector of FIGURE 4.

[0019] FIGURE 7 is a bottom perspective view of the dust collector of FIGURE 6 showing a first bottom lid for a first dust cup in a first open position and a second bottom lid for a second dust cup in a second open position.

[0020] FIGURE 8 is a right side cross-sectional view of a dual stage cyclone vacuum cleaner including a dust collector in accordance with a second embodiment of the present invention.

[0021] FIGURE 9 is an enlarged left side elevational view of the assembled dust collector of FIGURE 8.

[0022] FIGURE 10 is a right side elevational view of the assembled dust collector of FIGURE 9.

[0023] FIGURE 11 is a rear perspective view of the assembled dust collector of FIGURE 9.

[0024] FIGURE 12 is a cross-sectional of the assembled dust collector of FIGURE 11.

[0025] FIGURE 13 is a rear elevational view of the assembled dust collector of FIGURE 9.

[0026] FIGURE 14 is a cross-section view taken generally along section lines 14-14 of the assembled dust collector of FIGURE 13.

[0027] FIGURE 15 is a reduced cross-section view taken generally along section lines 15-15 of the assembled dust collector of FIGURE 13.

[0028] FIGURES 16 and 17 are enlarged bottom perspective views of the dust collector of FIGURES 9 and 10, respectively, showing a first bottom lid for a first dust cup and a second bottom lid for a second dust cup, with both lids in an open position.

[0029] FIGURE 18 is a front perspective view illustrating a dual stage cyclone vacuum cleaner including an assembled dust collector in accordance with a third embodiment of the present invention.

[0030] FIGURE 19 is a front perspective view of the dual stage vacuum cleaner of FIGURE 18 showing a first separator, a first dirt cup and a second dirt cup of the dust collector detached from the assembled dust collector.

[0031] FIGURE 20 is a front perspective view illustrating the dual stage cyclone vacuum cleaner of FIGURE 18 including an assembled dust collector in accordance with a fourth embodiment of the present invention.

[0032] FIGURE 21 is a front perspective view of the dual stage vacuum cleaner of FIGURE 20 showing a first separator and a first dirt cup detached from the assembled dust collector.

[0033] FIGURE 22 is a front perspective view of the dual stage vacuum cleaner of FIGURE 21 showing both the first dirt cup and second dirt cup separately detached from the assembled dust collector.

[0034] FIGURE 23 is a perspective view illustrating a dual stage cyclonic dust collector in accordance with a fifth embodiment of the present invention showing a bottom lid in an open position and a dirt collection cup removed from the dust collector.

[0035] FIGURE 24 is a cross-sectional view of the dual stage cyclonic dust collector of FIGURE 23 showing the dirt collection cup mounted within the dust collector.

[0036] FIGURE 25 is a perspective view illustrating a dual stage cyclonic dust collector in accordance with a sixth embodiment of the present invention showing a bottom lid in an open position and a dirt retention cap removed from the dust collector.

[0037] FIGURE 26 is a cross-sectional view of the dual stage cyclonic dust collector of FIGURE 25 showing the dirt retention cap mounted within the dust collector.

[0038] FIGURE 27 is a front perspective view illustrating a dual stage cyclone vacuum cleaner in accordance with a seventh embodiment of the present invention.

[0039] FIGURE 28 is a rear perspective view of the dual stage cyclone vacuum cleaner of FIGURE 27.

[0040] FIGURE 29 is a right side cross-sectional view of the dual stage cyclone vacuum cleaner of FIGURE 27.

[0041] FIGURE 30 is a front perspective view of an assembled dust collector for the dual stage vacuum cleaner of FIGURE 27.

[0042] FIGURE 31 is a rear perspective view of the assembled dust collector for the dual stage vacuum cleaner of FIGURE 27.

[0043] FIGURE 32 is an enlarged exploded perspective view of the dust collector of the dual stage vacuum cleaner of FIGURE 27, together with associated components thereof.

[0044] FIGURE 33 is a cross-sectional of the assembled dust collector of FIGURE 31.

[0045] FIGURE 34 is a bottom perspective view of the dust collector of FIGURE 30 showing a first bottom lid for a first dust cup in a first open position and a second bottom lid for a second dust cup in a second open position.

Detailed Description of the Invention

[0046] It should, of course, be understood that the description and drawings herein are merely illustrative and that various modifications and changes can be made in the

structures disclosed without departing from the scope and spirit of the invention. Like numerals refer to like parts throughout the several views. It will also be appreciated that the various identified components of the vacuum cleaner disclosed herein are merely terms of art that may vary from one manufacturer to another and should not be deemed to limit the present invention. While the invention is discussed in connection with an upright vacuum cleaner, it could also be adapted for use with a variety of other household cleaning appliances, such as carpet extractors, bare floor cleaners, "shop" type cleaners, canister cleaners, hand-held cleaners and built-in units. Moreover, the design could also be adapted for use with robotic units which are becoming more widespread.

[0047] Referring now to the drawings, wherein the drawings illustrate the preferred embodiments of the present invention only and are not intended to limit same, FIGURES 1 and 2 illustrate an upright dual stage vacuum cleaner 10 including a nozzle base 12 and an upper housing 14 mounted atop the nozzle base via conventional means. Mounted to one of the nozzle base and the upper housing is an electric motor and fan assembly 16. The upper housing 14 releasably supports a dust collector 20. The upper housing 14 and the nozzle base 12 are pivotally or hingedly connected through the use of trunnions or another suitable hinge assembly, so that the upper housing pivots between a generally vertical storage position (as shown) and an inclined use position. Both the nozzle base 12 and the upper housing 14 can be made from conventional materials, such as molded plastics and the like. A handle 22 extends upward from the upper housing 14, by which an operator of the dual stage cyclone vacuum cleaner 10 is able to grasp and maneuver the vacuum cleaner.

[0048] During vacuuming operations, the nozzle base 12 travels across a floor, carpet, or other subjacent surface being cleaned. As shown in FIGURE 2, an underside of the nozzle base includes a main suction opening 24 formed therein, which can extend substantially across the width of the nozzle at the front end thereof. As is known, the main suction opening is in fluid communication with the dust collector 20 through a conduit, which can be a center dirt passage 26. Of course, the dirt passage can also be located to either side of the center line of the upper housing 14 and the nozzle base 12. As best shown in FIGURE 1, the dirt passage includes a first section 30 having a longitudinal axis

generally parallel to a longitudinal axis of the dust collector and a second section **32** having a longitudinal axis generally normal to the axis of the first section. The second section directs dirt-laden air tangentially into the dust collector.

[0049] With continued reference to FIGURES 1 and 2, a connector hose assembly, such as at **38**, fluidly connects the air stream from the main suction opening to the center dirt passage. A rotating brush assembly (not visible) is positioned in the region of the nozzle main suction opening **24** for contacting and scrubbing the surface being vacuumed to loosen embedded dirt and dust. A plurality of wheels **44** and rollers **46** supports the nozzle base on the surface being cleaned and facilitates its movement thereacross. A latch assembly (not shown) can be mounted to the upper housing **14** for securing the dust collector thereto. A base member **50** can be mounted to the electric motor and fan assembly **16** for releasably supporting the dust collector **20**. A support brace (not visible) can extend from the upper housing **14** and attach to the center dirt passage to provide support.

[0050] The electric motor and fan assembly **16** is housed in a motor housing **60** which includes a hose connector **62** (FIGURE 2) and an exhaust duct (not visible). The motor and fan assembly generates the required suction airflow for cleaning operations by creating a suction force in a suction inlet and an exhaust force in an exhaust outlet. The motor and fan assembly airflow exhaust outlet can be in fluid communication with an exhaust grill (not visible) covering the exhaust duct. If desired, a final filter assembly can be provided for filtering the exhaust air stream of any contaminants which may have been picked up in the motor assembly immediately prior to its discharge into the atmosphere. The motor assembly suction inlet, on the other hand, is in fluid communication with the dust collector **20** of the vacuum cleaner **10** to generate a suction force therein.

[0051] With reference now to FIGURES 3 and 4, the dust collector **20** includes a cyclone main body **70**, an air manifold **74** and cover unit **76** attached to an upper portion of the cyclone main body, and a dirt cup **80** connected with a lower portion of the cyclone main body. The dirt cup includes a first dust collection chamber **82** and a second dust collection chamber **84**. The cyclone main body **70** includes a first cyclone part **88** and a second cyclone part **90**. As will be described in greater detail below, the first and second

dust collection chambers are configured to independently store and empty dirt and dust particles separated by the respective first and second cyclone parts. The dirt cup **80** and the first cyclone part **88** can be made of a transparent material so that the presence of dirt can be seen in the dust collector **20**.

[0052] As shown in FIGURES 5 and 6, a portion **92** of a first wall **94** of the first dust collection chamber **82** acts as a barrier between the first and second dust collection chambers **82** and **84**. The barrier is curved toward the second dust collection chamber such that the first collection chamber can be formed in a cylindrical shape. Thus, the first and second dust collection chambers are completely separated from each other such that the airflow in one of the chambers does not affect the airflow in the other of the chambers. This further improves the dust collection efficiency of the dust collector **20**.

[0053] As shown in FIGURES 5 and 6, the first cyclone part **88** comprises a generally frusto-conical shaped first stage cyclone separator **96**. The first stage separator includes a dirty air inlet conduit **98**, a top wall **100** and a sidewall **102** having an outer surface and an inner surface. The outer surface of the sidewall can form at least a part of an external surface of the vacuum cleaner **10**. A lower end **108** of the first stage cyclone separator is secured to a lower skirt **110**.

[0054] The conduit **98** has an inlet section **114** in fluid communication with an outlet end **116** of the center dirt passage **26** and an outlet section (not visible) in fluid communication with a dirty air inlet (not visible) of the first stage separator **96**. The dirty air inlet of the separator can be generally rectangular in cross-section. It should be appreciated that the outlet section can have a varying dimension which allows the air stream to be drawn into the first stage separator **96** by way of the venturi effect, which increases the velocity of the air stream and creates an increased vacuum in the separator dirty air inlet. For example, the dirty air inlet conduit **98** can include a decreasing cross-sectional area. Alternatively, the dirty air conduit can transition from a rectangular cross-sectional area into, for example, a venturi-type discharge opening or a round discharge opening.

[0055] In the depicted embodiment, the conduit **98** has an enlarged inlet **120** having an inner dimension greater than an outer dimension of the outlet end **116** of the second section **32** of the center dirt passage **26**, such that the outlet end is frictionally received in the

enlarged inlet. However, it should be appreciated that other known ways of securing these components together are also contemplated.

[0056] The airflow into the first stage separator **96** is tangential which causes a vortex-type, cyclonic or swirling flow. Such vortex flow is directed downwardly in the first stage separator by the top wall **100**. Cyclonic action in the first stage separator **96** removes a substantial portion of the entrained dust and dirt from the suction air stream and causes the dust and dirt to be deposited in the first dust collection chamber **82** of the dirt cup **80**. As shown in FIGURE 6, the lower skirt **110** is secured to an upper portion of the first wall **94** of the first dust collection chamber **82** via conventional means.

[0057] Operably secured to the dust collector **20** is a first closure member or bottom plate or lid **130**, which allows for emptying of the first dust collection chamber **82**. In the depicted embodiment, the bottom lid is pivotally secured to a lower portion of the first wall **94** of the dirt cup **80**; although, this is not required. A seal ring (not shown) can be fitted around the first bottom lid to create a seal between the first lid and the dirt cup. As shown in FIGURE 7, a first hinge assembly **132** can be used to mount the first bottom lid **130** to a bottom portion of the dirt cup. The first hinge assembly allows the first bottom lid to be selectively opened so that dirt and dust particles that were separated from the air stream by the first stage separator **96** can be emptied from the first dust collection chamber **82**. A first latch assembly (not shown) can be located diametrically opposed from the first hinge assembly **132**. Normally, the first latch assembly maintains the first bottom lid **130** in a closed position.

[0058] With reference to FIGURES 5 and 6, fluidly connecting the first cyclone part **88** to the second cyclone part **90** is a perforated tube **140**. The perforated tube is disposed within the first stage separator **96** and extends longitudinally from the top wall **100** of the separator. In the present embodiment, the perforated tube has a longitudinal axis coincident with the longitudinal axes of the first stage separator **96** and the first dust collection chamber **82** thereby creating a central air path; although, it should be appreciated that the respective axes can be spaced from each other. In the depicted embodiment, the perforated tube includes a generally cylindrical section **142**. A plurality of openings or perforations **144** is located around a portion of the circumference of the

cylindrical section. The openings are useful for removing threads and fibers from the air stream which flows into the perforated tube. As might be expected, the diameter of the openings **144** and the number of those openings within the perforated tube **140** directly affect the filtration process occurring within the dirt cup. Also, additional openings result in a larger total opening area and thus the airflow rate through each opening is reduced. Thus, there is a smaller pressure drop and lighter dust and dirt particles will not be as likely to block the openings. The openings **144** serve as an outlet from the first stage separator **96**, allowing the partially cleaned air to enter the second cyclone part **90**. It should be appreciated that the cylindrical section **142** can have a varying dimension which allows the air stream to be drawn into the perforated tube **140** by way of the venturi effect, which increases the velocity of the air stream flowing through the perforated tube and creates an increased vacuum in the openings **144**. For example, the cylindrical section **142** can include a decreasing cross-sectional area.

[0059] The perforated tube **140** can also include at least one fin (not shown) mounted to an inside surface of the cylindrical section **142** and extending generally longitudinally through the perforated tube. The at least one fin eliminates cyclonic flow inside the perforated tube.

[0060] An upper end **146** of the perforated tube is mounted to a mouth **148** extending downwardly from the top wall **100** of the first stage separator **96**. In particular, the upper end of the perforated tube has an inner diameter greater than an outer diameter of the mouth such that the mouth is received in the upper end. These two elements can be secured together by adhesives, frictional welding or the like. It can be appreciated that the perforated tube can be made removable from the dust collector **20** for cleaning purposes.

[0061] Connected to a lower, closed end **150** of the perforated tube is a shroud **152** for retarding an upward flow of dirt and dust particles that have fallen below the lower end **108** of the first stage separator **96**. The shroud has an outwardly flared section **160** and a flange **162** extending downwardly from the flared section. As is best illustrated in FIGURE 6, a diameter of the shroud, particularly an end of the outwardly flared section, is larger than a diameter of the separator lower end **108** and an inside diameter of the first dust collection chamber **82** is substantially larger than the diameter of the separator lower end.

This prevents dust from being picked up by flow of air streaming from the first dust collection chamber 82 toward the openings 144 of the perforated tube 140. The flared section 160 of the shroud 152, which is generally parallel to the lower skirt 110, and the lower skirt define a first air channel 170. The shroud flange 162, which is generally parallel to the first dust collection chamber wall 94, and the wall define a second air channel 172. The first and second air channels direct air from the first stage separator 96 into the first dust collection chamber 82. The first air channel and the second air channel have a substantially constant volume for maintaining airflow velocity. Also, the volume of the first air channel is approximately equal to the volume of the second air channel.

[0062] A laminar flow member, such as one or more baffles or fins 176, is mounted to the closed lower end 150 of the perforated tube 140. At least a portion of the laminar flow member is encircled by the shroud 152. The laminar flow member extends generally along a longitudinal axis of the perforated tube and partially into the first dust collection chamber 82. As shown in FIGURE 5, the depicted baffle 176 can be cruciform in shape and include a cross blade assembly, which can be formed of two flat blade pieces that are oriented approximately perpendicular to each other. It should be appreciated that the baffles 176 are not limited to the configuration shown in FIGURE 5 but may be formed of various shapes. For example, if a blade is employed, it can have a rectangular shape, a triangular shape or an elliptical shape, when viewed from its side. Also, in addition to a cross blade design, other designs are also contemplated. Such designs can include blades that are oriented at angles other than normal to each other or that use more than two sets of blades. The blades can be twisted along their length, if so desired, as this may reduce the noise generated by the vacuum cleaner's cyclonic operation. These baffles can assist in allowing dirt and dust particles to fall out of the air stream between the perforated tube lower end 150 and the first bottom lid 130 of the first dust collection chamber 82.

[0063] With continued reference to FIGURES 5 and 6, an upper end or air outlet 180 of the perforated tube 140 is in fluid communication with an air inlet section 182 of the air manifold 74 positioned above the first stage separator 96. The air manifold includes a top

guide plate **190** and a bottom guide plate **192**. The guide plates direct partially cleaned air from the perforated tube **140** to the second cyclone part **90**.

[0064] The top guide plate **190** is provided under the cover unit **76** and includes a wall **194**. Extending downwardly from a first end portion **198** of the wall is a generally arcuate flange **200**, which forms a portion of the manifold air inlet section **182**. Located at a second end portion **204** of the top wall **194** is a plurality of discharge guide tubes **208**. As shown in FIGURE 5, each of the discharge guide tube **208** has a generally cylindrical shape and projects downward from the top guide plate **190**. The discharge guide tubes direct the cleaned air exhausted from the second cyclone part **90** into the cover unit **76**. Each discharge guide tube can include a laminar flow member to stop the air from circulating within the discharge tube. As shown in FIGURE 5, the laminar flow member is a generally cross-shaped baffle **210**. However, it should be appreciated that other shapes are also contemplated. A portion of the baffle projects a predetermined distance from a lowermost end of each discharge guide tube into the interior of the second cyclone part. The cross-sectional area of the baffle at any point along its length can be generally cross-shaped.

[0065] The bottom guide plate **192** is spaced away from the top guide plate **190** by a generally continuous, peripheral barrier **212** extending upwardly from a wall **214**. The barrier abuts against a bottom surface of wall **194** and flange **200** to define an air passage from the manifold air inlet section **194** to the second cyclone part **90**.

[0066] With reference again to FIGURE 5, the second cyclone part comprises a plurality of spaced apart, frusto-conical, downstream, second stage cyclonic separators **220**. The downstream separators are arranged in parallel and are mounted radially on the air manifold **74** outside of the first cyclone part **88**. In the depicted embodiment, the downstream separators project downwardly from the wall **214** of the bottom guide plate **192** such that uppermost end **222** of each downstream separator is located approximately in the same plane defined by the top wall **100** of the first stage separator **96**. Each downstream separator **220** includes a dirty air inlet **224** in fluid communication with the air passage defined by the guide plates **190** and **192**. In particular, the air passage is separated into a plurality of isolated air conduits **228** by a plurality of dividing walls **230** extending inwardly

from the barrier **212**. The dividing walls at least partially surround the dirty air inlet of each downstream separator. Each manifold air conduit **228** has an air outlet **234** which directs a volume of partially cleaned air generally tangentially into the inlet **224** of each second stage separator **220**. This causes a vortex-type, cyclonic or swirling flow. Such vortex flow is directed downwardly in the downstream separator since a top end thereof is blocked by the bottom surface of wall **204**. Each second stage or downstream separator **220** can have a dimensional relationship such that a diameter of its upper end is three times the diameter of its lower end. This relationship is seen to improve the efficiency of cyclonic separation. An outer cover **240** at least partially encases or surrounds the plurality of downstream separators **220**. The outlet cover can be secured to the bottom guide plate **192** via conventional fasteners.

[0067] With reference again to FIGURE 5, each downstream separator **220** includes a dust blocking member **250** having a connection member **252** and a dust blocking plate **254**. The connecting member is mounted to a lower end **256** of each downstream separator **220**. In this embodiment, an upper portion of the connecting member is integrally formed with the separator lower end; although, this is not required. The dust blocking plate **254** is attached to a lower portion of the connecting member so as to be spaced from a particle outlet **260** of the downstream separator by a predetermined distance. The blocking plate limits turbulence in the second dust collection chamber **84** attached to a lower portion of the outer cover **240** and prevents dirt that has fallen into the second dust collection chamber from becoming mixed into the cleaned air exiting each downstream separator. The lower end **256** of each second stage separator **220** and a bottom surface of the dust blocking plate **254** can be inclined at an acute angle of approximately fifteen degrees (15°) relative to a longitudinal axis of each separator. This configuration allows dirt to easily pass downwardly through the particle outlet **260** and into the second dust collection chamber **84** reducing risk of dirt collecting in the area of the particle outlet and causing a blockage.

[0068] The dirt separated by each downstream separator **220** is collected in the second dust collection chamber **84**. With reference again to FIGURE 7, operably secured to the dust collector **20** is a second closure member or bottom plate or lid **272**, which allows for

independent emptying of the second dust collection chamber **84**. In the depicted embodiment, the bottom lid **272** is pivotally secured to a lower portion of a second wall **270** of the dirt cup **80**; although, this is not required. Instead, the lid **272** could be indirectly secured to the dirt cup if so desired. A seal ring (not shown) can be fitted around the second bottom lid to create a seal between the second lid and the dirt cup. A second hinge assembly **274** can be used to mount the second bottom lid **270** to a bottom portion of the dirt cup. The second hinge assembly allows the second bottom lid to be independently selectively opened so that dirt and dust particles that were separated from the air stream by the downstream separators **220** can be emptied from the second dust collection chamber **84**. A second latch assembly (not shown) can be located diametrically opposed from the second hinge assembly **274**. Normally, the second latch assembly maintains the second bottom lid **270** in a closed position.

[0069] As indicated previously, each discharge guide tube **208** directs the cleaned air exhausted from the second cyclone part **90** into the cover unit **76** before being discharged to an inlet of the electric motor and fan assembly **16**. As shown in FIGURE 5, the cyclone cover **76** includes a bottom plenum **280** and a top plenum **282**. The bottom plenum can be hinged to provide access to the second stage separators for cleaning. The bottom plenum collects a flow of cleaned air from the downstream separators **220** and directs the cleaned air through a two stage filter assembly **288** for filtering any remaining fine dust remaining in the airflow exiting the downstream separators. In this embodiment, the two stage filter element **288** includes at least one foam filter. Such a filter can be a compound member with a coarse foam layer **290** and a fine foam layer **292**, at least partially housed in the bottom plenum **288**. The two foam layers can, if desired, be secured to each other by conventional means. Located downstream therefrom can be a pleated filter **294**, such as a High-Efficiency Particulate Arresting (HEPA) grade filter, housed in the top plenum **282**. By housing the pleated filter in the cover unit **76**, there is no need for an additional filter plenum and the foam filters are separated from the pleated filter. The two stage filter element **288** and the pleated filter **294** can both be easily serviced by removing the top plenum from the bottom plenum. For example, the top plenum can be pivotally mounted to the bottom plenum.

This separation of the filters prevents transfer of dust from the two stage filter element to the pleated filter during service.

[0070] With reference to FIGURES 1 and 5, the top plenum 282 collects a flow of cleaned air from the filter assembly and merges the flow of cleaned air into a first cleaned air outlet conduit 300. The first outlet conduit has a first section 302 projecting radially from the cover unit and a downwardly projecting second section 304. A second cleaned air conduit 310 is attached to an end 312 of the first conduit. In this embodiment, the end 312 of the first conduit has an inner diameter greater than an outer diameter of a first end 314 of the second conduit such that the first end is frictionally received in the end 312. The second conduit has a longitudinal axis which is oriented approximately parallel to the longitudinal axis of the dust collector 20. An outlet end 320 of the second conduit is attached to the hose connector 62 of the motor housing 60 and is in fluid communication with the inlet of the electric motor and fan assembly 16.

[0071] In operation, dirt entrained air passes into the upstream, first cyclone separator 96 through the inlet 98 which is oriented tangentially with respect to the sidewall 102 of the separator. The air then travels around the separation chamber where many of the particles entrained in the air are caused, by centrifugal force, to travel along the interior surface of the sidewall of the separator 96 and drop out of the rotating air flow by gravity. However, relatively light, fine dust is less subject to a centrifugal force. Accordingly, fine dust may be contained in the airflow circulating near the bottom portion of the dirt cup. Since the cross blade 176 extends into the bottom portion of the first dust collection chamber 82 of the dirt cup 80, the circulating airflow hits the blade assembly and further rotation is stopped, thereby forming a laminar flow. In addition, if desired, extending inwardly from a bottom portion of the wall 94 of the first dust collection chamber 82 can be laminar flow members (not visible) which further prevent the rotation of air in the bottom of the dirt cup. As a result, the most of the fine dust entrained in the air is also allowed to drop out.

[0072] The partially cleaned air travels through the openings 144 of the perforated tube 140. The partially cleaned air then travels through the air manifold 74 mounted above the perforated tube and into the frusto-conical downstream cyclonic separators 220. There, the air cyclones or spirals down the inner surfaces of the cyclonic separators before

moving upward through the discharge guide tubes **208** and into the cover unit **76**. The baffle **210** causes the air flowing through each discharge guide tube to be a laminar flow. Fine dirt separated in the downstream cyclonic separators collects in the second dust collection chamber **84**. The cleaned air flows out of the downstream separators into the bottom plenum **280**, through the filter assembly **288**, into the upper plenum **282** and into the first and second conduits **300**, **310**, respectively. It will be appreciated that the volume of the bottom plenum before the foam filter can be generally the same as the volume of the upper plenum after the pleated filter. The conduits are in fluid communication with the air inlet to the electric motor and fan assembly **16**.

[0073] To empty the dirt collected in the first dust collection chamber, the first bottom lid **130** can be opened. To empty the dirt collected in the second collection chamber, the second bottom lid **270** can be opened, independent of the first bottom lid. Each bottom lid **130** and **270** can include a device to delay the opening of the bottom lid and/or moderate movement of the bottom lid, causing the bottom lid, on release from its closed position, to be opened smoothly yet steadily and slowly. This delayed or slowed movement retards the reintroduction of the dirt collected in each collection chamber **82**, **84** into ambient air. The device can include conventional damping devices, such as a spring, piston and the like, and/or a mechanism integrated in each bottom lid or the dirt cup **80**. It should also be appreciated that the bottom lids can be configured such that the second bottom lid can not be opened until the first bottom lid is opened. For example, this can be accomplished by any known type of mechanical interlock of the two lids.

[0074] Similar to the aforementioned embodiment, a second embodiment of a dust collector for a dual stage cyclone vacuum cleaner is shown in FIGURES 8-17. Since most of the structure and function is substantially identical, reference numerals with a single primed suffix (') refer to like components (e.g., vacuum cleaner **10** is referred to by reference numeral **10'**), and new numerals identify new components in the additional embodiment.

[0075] With reference now to FIGURES 8-12, a dust collector **402** for the dual stage cyclone vacuum cleaner **10'** includes a cyclone main body **404**, an air manifold **406** and cover unit **408** attached to an upper portion of the cyclone main body, and a dirt cup **410**

connected with the cyclone main body. The dirt cup includes a first dust collection chamber 412 and a second dust collection chamber 414. The cyclone main body 404 includes a first cyclone part or first cyclonic stage 418 and a second cyclone part or second cyclonic stage 420. Similar to the previous embodiment, the first and second dust collection chambers are configured to independently store and empty dirt and dust particles separated by the respective first and second cyclone parts.

[0076] As shown in FIGURES 12 and 13, the second dust collection chamber 414 includes an upper collection section 428 in communication with a lower collection section 430. The upper collection section generally surrounds an upper portion of the first cyclone part 418. As shown in FIGURES 9-11, a bottom portion 432 of the upper collection section 428 is tapered to promote sliding and transferring of remaining dust particles separated by the second cyclone part 420 from the upper collection section 428 into the lower collection section 430. The lower collection section extends outwardly from a sidewall 434 of the first dust collection chamber 412. Thus, the first and second dust collection chambers are completely separated from each other such that the airflow in one of the chambers does not affect the airflow in the other of the chambers. This further improves the dust collection efficiency of the dust collector 402. In the depicted embodiment, a portion of the upper collection section 428, which is in communication with the lower collection section 430, and the lower collection section are generally box-like; although, this is not required. Alternative conformations are also contemplated.

[0077] With reference again to FIGURE 8, and additional reference to FIGURE 14, the first cyclone part 418 comprises a generally cylindrical shaped first stage cyclone separator 440. However, it should be appreciated that the first cyclone part can comprise a generally frusto-conical shaped first stage cyclone separator. The first stage separator includes a dirty air inlet conduit 442, a top wall 444 and a sidewall 446 having an outer surface and an inner surface. The outer surface of the sidewall can form at least a part of an external surface of the vacuum cleaner 10'. The airflow into the first stage separator 440 is tangential which causes a vortex-type, cyclonic or swirling flow. Such vortex flow is directed downwardly in the first stage separator by the top wall 444. Cyclonic action in the first stage separator removes a substantial portion of the entrained dust and dirt from the

suction air stream and causes the dust and dirt to be deposited in the first dust collection chamber **412** of the dirt cup **410**.

[0078] With reference to FIGURES 16 and 17, pivotally secured to a lower portion of the wall **434** of the first dust collection chamber **412** is a first bottom plate or lid **450**, which allows for emptying of the first dust collection chamber **412**. A seal ring (not shown) can be fitted around the first bottom lid to create a seal between the first lid and the dirt cup. A first hinge assembly **452** can be used to mount the first bottom lid **450** to a bottom portion of the dirt cup **410**. The first hinge assembly allows the first bottom lid to be selectively opened so that dirt and dust particles that were separated from the air stream by the first stage separator **440** can be emptied from the first dust collection chamber **412**. A first conventional latch assembly (not shown), which can be located diametrically opposed from the first hinge assembly **452**, normally maintains the first bottom lid **450** in a closed position.

[0079] Similar to the previous embodiment, and with reference to FIGURES 12 and 14, fluidly connecting the first cyclone part **418** to the second cyclone part **420** is a perforated tube **460**. The perforated tube is disposed within the first stage separator **440** and extends longitudinally therein. The perforated tube includes a generally cylindrical section **462** including a plurality of openings or perforations **464** located around a portion of the circumference of the cylindrical section. The openings **464** serve as an outlet from the first stage separator **440**, allowing the partially cleaned fluid to enter the second cyclone part **420**. The perforated tube **460** can also include at least one internally mounted fin to eliminate cyclonic flow inside the perforated tube.

[0080] Connected to a lower, closed end **470** of the perforated tube is a shroud **472** for retarding an upward flow of dirt and dust particles that have fallen below the first stage separator **440**. A laminar flow member, such as one or more baffles or fins **476**, is mounted to the closed lower end **470** of the perforated tube **460**. At least a portion of the laminar flow member is encircled by the shroud **472**. With reference again to FIGURES 12 and 14, an upper end or air outlet **480** of the perforated tube **460** is in fluid communication with an air inlet section **482** of the air manifold **406** positioned above the first stage separator **440**. In the depicted embodiment, the air inlet section **482** has a varying

dimension. Specifically, the air inlet section includes a first, lower end connected to the air outlet **480** of the perforated tube **460** and a second, upper end connected to an air outlet section **490** of the air manifold **406**. The air inlet section first end has a first dimension and the air inlet section second end has a smaller second dimension. This decreasing cross-sectional area allows the air stream to be drawn into the perforated tube **460** by way of the venturi effect, which increases the velocity of the air stream flowing through the perforated tube and creates an increased vacuum in the openings **464**. Alternatively, the air inlet section can have a constant longitudinal dimension approximately equal to a dimension of the cylindrical section of the perforated tube (i.e., a diameter of the air inlet section is approximately equal to a diameter of the perforated tube).

[0081] As shown in FIGURE 14, the air manifold **406** includes the air inlet section **482**, the air outlet section **490** and an air guide **494** provided under the cover unit **408**. Both the air inlet section and the air outlet section have a longitudinal axis coincident with the longitudinal axis of the perforated tube **460**. The air guide includes an opening **496** dimensioned to receive a portion of the air outlet section **490**. As will be described in greater detail below, the air guide further includes an air passage in fluid communication with the air outlet section for directing partially cleaned air from the perforated tube **460** to the second cyclone part **420**.

[0082] With reference again to FIGURES 12 and 14, and similar to the previous embodiment, the second cyclone part **420** comprises a plurality of spaced apart, frusto-conical, downstream, second stage cyclonic separators **500**. The downstream separators are arranged in parallel and are mounted radially on the air manifold **406** above of the first cyclone part **418**. The separators project downwardly from the air guide **494** at least partially into the upper collection section **428** of the second dust collection chamber **414**. As shown in FIGURE 15, each downstream separator **500** includes a dirty air inlet **502** in fluid communication with the air passage defined by the air guide **494**. In particular, the air passage is separated into a plurality of isolated air conduits **510**, which extend from the opening **496**, by a plurality of dividing walls **512**. The dividing walls at least partially surround the dirty air inlet of each downstream separator. Each manifold air conduit **510** has an air outlet **514** which directs a volume of partially cleaned air generally tangentially into

the inlet 502 of each second stage separator 500. This causes a vortex-type, cyclonic or swirling flow. Such vortex flow is directed downwardly in the downstream separator since a top end thereof is blocked by the air guide 494. An outer cover (not visible), which can be secured to the dust collector 402, can at least partially encase or surround the plurality of downstream separators 500.

[0083] With reference again to FIGURE 14, each downstream separator 500 includes a dust blocking member 520 which limits turbulence in the second dust collection chamber 414 and prevents re-entrainment of dirt that has fallen into the second dust collection chamber into the cleaned air exiting each downstream separator.

[0084] The dirt separated by each downstream separator 200 is collected in the second dust collection chamber 414. With reference again to FIGURES 16 and 17, pivotally secured to a lower portion of a wall 530 of the second dust collection chamber 414 is a second bottom plate or lid 532, which allows for independent emptying of the second dust collection chamber. Again, a seal ring (not shown) can be fitted around the second bottom lid to create a seal between the second lid and the dirt cup. A second hinge assembly 534 can be used to mount the second bottom lid 532 to a bottom portion of the dirt cup. The second hinge assembly allows the second bottom lid to be independently selectively opened so that remaining dirt and dust particles that were separated from the air stream by the downstream separators 500 can be emptied from the second dust collection chamber 84. A second latch assembly, which can be located diametrically opposed from the second hinge assembly 534, normally maintains the second bottom lid 532 in a closed position.

[0085] As shown in FIGURES 14 and 15, located on the air guide 494 and projecting downwardly therefrom is a plurality of discharge guide tubes 540. The discharge guide tubes direct clean air exhausted from the second cyclone part 420 into the cover unit 408 before being discharged to an inlet of the electric motor and fan assembly 16'. Each discharge guide tube 250 can include a laminar flow member, such as a generally cross-shaped baffle 542, to stop the air from circulating within the discharge tube.

[0086] As to a further discussion of the structure, manner of usage and operation of the second embodiment, the same should be apparent from the above description relative to

the first embodiment. Accordingly, no further discussion relating to the manner of usage and operation will be provided.

[0087] Similar to the aforementioned embodiments, a third embodiment of a dual stage cyclone vacuum cleaner and a dust collector are shown in FIGURES 18 and 19.

[0088] With reference to FIGURE 18, an upright dual stage vacuum cleaner **600** generally includes an electric motor and fan assembly **602**, a nozzle base **604**, and a housing **610** pivotally or hingedly mounted atop the nozzle base via conventional means. A handle **614** extends upward from the housing, by which an operator of the dual stage cyclone vacuum cleaner is able to grasp and maneuver the vacuum cleaner. An underside of the nozzle base includes a main suction opening **616** formed therein, which is in fluid communication with a dust collector **618** through a conduit **620**. A section **622** of the conduit directs dust-laden air tangentially into the dust collector. A base member **628** of the housing **610** can be mounted to a motor housing **630** of the electric motor and fan assembly **602** for releasably supporting the dust collector **618**. A latch assembly (not shown) can be mounted to the base member **628** for releasably securing the dust collector thereto.

[0089] With reference to FIGURE 19, the housing **610** includes a cyclone main body **640**, an air manifold **642** and cover unit **646** attached to an upper portion of the cyclone main body, and a dirt cup **650** connected with a lower portion of the cyclone main body. The dirt cup includes a first dust collection chamber **652** and a second dust collection chamber **654**. The cyclone main body **640** includes a first cyclone part **658** and a separate second cyclone part **660**. The first cyclone part comprises a generally frusto-conical shaped first stage cyclone separator **670** mounted atop the first dust collection chamber **652**. The second cyclone part comprises a plurality of spaced apart, frusto-conical, downstream, second stage cyclonic separators (not visible) arranged in parallel and mounted radially on the air manifold **642** outside of the first cyclone part **658**. An outer cover **676**, which is releasably mounted atop the second dust collection chamber **654**, at least partially encases or surrounds the plurality of downstream separators. A flange **678** extends inwardly from an end **682** of the outer cover and sealingly abuts an outer surface of a sidewall **686** of the first cyclone part.

[0090] Similar to the previous embodiments, the first and second dust collection chambers **652**, **654** are configured to independently store and empty dirt and dust particles separated by the respective first and second cyclone parts **658**, **660**. Pivotaly secured to a lower portion of a sidewall **690** of the first collection chamber **652** is a first bottom plate or lid **692**. Pivotaly secured to a lower portion of a sidewall **696** of the second collection chamber **654** is a second bottom plate or lid **698**. Each bottom lid can be separately opened which allows for independent emptying of its respective dust collection chamber. A single compound hinge assembly (not visible) or separate hinge assemblies (not visible) can be used to mount the bottom lids to a bottom portion of the dirt cup.

[0091] As discussed above with respect to the operation of the previous embodiment, the first cyclone part separates dust from dust-laden air and the second cyclone part separates remaining dust particles from the air. As such, the first collection chamber **652** requires emptying more frequently than the second collection chamber **654**. The dirt-laden air is exhausted from the second cyclone part **660** into the cover unit **646** before being discharged through a cleaned air conduit **704** to an inlet (not visible) of the electric motor and fan assembly **602**.

[0092] With continued reference to FIGURE 19, the first cyclone part **658**, the first dust collection chamber **652** and the second dust collection chamber **654** can be selectively detached from the dust collector **610**. The second cyclone part **660** remains removably mounted to the dust collector, which again can also be selectively detached from the vacuum cleaner **600**. In this version, a common wall is shared by the collection chambers. Specifically, sidewall **696**, which can be integrally formed with sidewall **690**, extends outwardly from sidewall **690**. An inner wall **710** acts as a barrier between the first and second dust collection chambers **652** and **654**. A handle **720** can be attached to one of the first cyclone part and the first dust collection chamber to aid in the removal and subsequent handling of the detached unit.

[0093] Similar to the third embodiment, a fourth embodiment of a dust collector for a dual stage cyclone vacuum cleaner is shown in FIGURES 20-22. Since most of the structure and function of the fourth embodiment is substantially identical to the third embodiment, reference numerals with a single primed suffix (') refer to like components

(e.g., vacuum cleaner 600 is referred to by reference numeral 600'), and new numerals identify new components in the additional embodiment.

[0094] With reference to FIGURE 21, the first cyclone part 658' and the first dust collection chamber 652' can be selectively detached from the housing 610'. The second cyclone part 660' and the second dust collection chamber 654' can remain removably mounted to the housing. In this embodiment, no common wall is shared by the collection chambers, each sidewall 690' and 696' enclosing its respective dust collection chamber 652' and 654'. Because the first collection chamber 652' requires emptying more frequently than the second collection chamber 654', the first dust collection chamber can be detached for cleaning without removing the second dust collection chamber. This minimizes the amount of fine dust introduced into ambient air during servicing of the vacuum cleaner.

[0095] With reference to FIGURE 22, the second collection chamber 654' can also be independently detached from the housing 610' to empty the collected fine dust. Particularly, the second collection chamber is detached from the outer cover 676', the second cyclone part remaining removably mounted to the housing. A second handle 730 can be attached to the second dust collection chamber to aid in the removal and subsequent handling of the detached unit.

[0096] In this embodiment of the housing 610', separate hinge assemblies (not visible) can be used to mount the bottom opening lids 692' and 698' of the respective first and second dust collection chambers 652' and 654'. Additionally, in the above embodiments, the first and second dust collection chambers are completely separated from each other such that the airflow in one of the chambers does not affect the airflow in the other of the chambers, thereby improving the dust collection efficiency of the dust collector. It should be noted that one or both of the cyclonic stages 658' and 660' can be detached from the housing 610'. Also, each of the dust collection chambers 652' and 654' can be detached from the housing.

[0097] As to a further discussion of the manner of usage and operation of the third and fourth embodiments, the same should be apparent from the above description relative to

the first embodiment. Accordingly, no further discussion relating to the manner of usage and operation will be provided.

[0098] Fifth and sixth embodiments of a dual stage cyclonic dust collector are shown in FIGURES 23-24 and FIGURES 26-26, respectively.

[0099] In the fifth embodiment, a dust collector **800** includes a cyclone main body **810** and lid or cover unit **812** attached to an upper portion of the cyclone main body. The cyclone main body **810** includes a first cyclone part **820** and a separate second cyclone part **822**. The first cyclone part comprises a generally cylindrical-shaped first stage cyclone separator **830**. The second cyclone part comprises a plurality of spaced apart, frusto-conical, downstream, second stage cyclonic separators **832** arranged in parallel and mounted outside of the first cyclone part **820**. The cover unit at least partially encases or surrounds the plurality of downstream separators.

[00100] Fluidly connecting the first cyclone part **820** to the second cyclone part **822** is a perforated tube **840**. The perforated tube is disposed within the first stage separator **830** and extends longitudinally, downwardly from a top wall **842** of the separator. The perforated tube includes a cylindrical section **844** which is generally parallel to the interior surface of a separator sidewall **846**. A plurality of openings **850** is located around a portion of the circumference of the cylindrical section. The openings serve as an outlet from the first stage separator to the second stage separators. A lower end of the perforated tube is closed by a generally tubular member **854**. An open upper end **856** of the tubular member is in communication with an open lower end **858** of a generally frusto-conical shaped member **860** disposed within the perforated tube. An upper open end **864** of the frusto-conical member **860** is connected to a sidewall **868** of the second cyclone part **822**. An open lower end **870** of the tubular member **854** is closed by a bottom lid or cover **880**, which is hingedly connected to the cyclone main body **810**.

[00101] As discussed previously with respect to the operation of the first embodiment, the first cyclone part separates dust from dust-laden air and the second cyclone part separates remaining dust particles from the air. The cleaned air is exhausted from the second stage separators **832** into the cover unit **812** before being discharged through a cleaned air outlet **882** to an inlet of an electric motor and fan assembly. Dirt separated in

the first stage separator collects on the bottom lid **880**. Fine dirt separated in the downstream cyclonic separators falls down the frusto-conical member **860** and into the tubular member **854**.

[00102] In the fifth embodiment of FIGURES 23 and 24, located within the tubular member and adjacent the bottom lid is a removable dirt collection cup **890** having an open upper end **892** and a closed lower end **894**. A seal ring can be fitted around at least one of the cup upper and lower end to create a seal between the dirt collection cup and the tubular member. The dirt collection cup is configured to collect the separated fine dirt. Thus, the dust collector **800** is configured to independently store and separately empty dirt and dust particles separated by the respective first and second cyclone parts **820**, **822**. To empty the dirt separated by the first stage separator, the bottom lid **880** can be opened. To empty the dirt separated by the second stage separators, the dirt collection cup **890** can be detached from the tubular member **854** and emptied. This minimizes the amount of fine dust introduced into ambient air during servicing of the household cleaning appliances. A separately emptying second dirt collection cup is advantageous since the first stage dirt collection chamber fills much more frequently than does the second stage dirt collection chamber or cup. The cup can be transparent so as to visibly indicate when emptying is needed.

[00103] In the sixth embodiment of FIGURES 25 and 26, like components are identified by like numerals with a primed (') suffix and new components are identified by new numerals. In this embodiment, a dirt retention cap **900** can be removably secured within a tubular member **854'** via conventional means. For example, the cap can be threadedly secured within the tubular member. It should be appreciated that alternate means for removably securing the cap are also contemplated. A seal ring can be fitted around the cap to create a seal between the cap and the tubular member. Fine dirt separated in several downstream cyclonic separators **832'** collects in the tubular member **854'** on the cap **900**. To empty the collected fine dirt, the cap is removed from the tubular member. The cap **900** can be transparent, as can at least the lower portion of the tubular member **854'**, in order to allow a user to see when emptying is needed.

[00104] In another embodiment (not illustrated), a second bottom lid can be pivotally mounted within the tubular member **854'** to collect the fine dirt separated by the downstream separators **832'**. Again, a seal ring can be fitted around the second bottom lid to create a seal between the second lid and the tubular member. A second hinge assembly can be used to mount the second bottom lid to a bottom portion of the tubular member. Each bottom lid can be separately opened which allows for independent, selective emptying of dirt and dust particles separated by the respective first and second cyclone parts.

[00105] Similar to the first and second embodiments, a seventh embodiment of a dust collector for a dual stage cyclone vacuum cleaner is shown in FIGURES 27-34.

[00106] With reference to FIGURE 27-29, an upright dual stage vacuum cleaner **1000** generally includes a nozzle base **1002** and a housing **1004** mounted atop the nozzle base via conventional means. Mounted to one of the nozzle base and the upper housing is an electric motor and fan assembly **1006**. A handle **1008** extends upward from the housing, by which an operator of the dual stage cyclone vacuum cleaner is able to grasp and maneuver the vacuum cleaner. An underside of the nozzle base includes a main suction opening **1010** formed therein, which is in fluid communication with a dust collector **1020** through a conduit **1022**. A section **1024** of the conduit directs dust-laden air tangentially into the dust collector. A latch assembly **1026** can be mounted to the dust collector for releasably securing the dust collector to the housing.

[00107] With reference to FIGURES 30-32, the dust collector **1020** includes a cyclone main body **1040**, an air manifold **1042** and cover unit **1046** attached to an upper portion of the cyclone main body, and a dirt cup **1050** connected with a lower portion of the cyclone main body. The dirt cup includes a first dust collection chamber **1052** and a second dust collection chamber **1054**. Similar to the previous embodiments, the first and second dust collection chambers are configured to independently store and empty dirt and dust particles separated by the respective first and second cyclone parts.

[00108] The cyclone main body **1040** includes a first cyclone part **1058** and a separate second cyclone part **1060**. The first cyclone part comprises a generally frusto-conical shaped first stage cyclone separator **1070** mounted atop the first dust collection chamber

1052. However, it should be appreciated that the first cyclone part can comprise a generally cylindrical shaped first stage cyclone separator. The second cyclone part comprises a plurality of spaced apart, frusto-conical, downstream, second stage cyclonic separators **1072** arranged in parallel and mounted on the air manifold **1042** outside of the first cyclone part **1058**. An outer cover **1076**, which is releasably mounted atop the second dust collection chamber **1054**, at least partially encases or surrounds the plurality of downstream separators. The outer cover sealingly abuts an outer surface of a sidewall **1086** of the first cyclone part.

[00109] With reference again to FIGURE 32, and additional reference to FIGURE 33, the first stage separator **1070** includes a dirty air inlet conduit **1090** and the sidewall **1086** having an outer surface and an inner surface. The outer surface of the sidewall can form at least a part of an external surface of the vacuum cleaner **1000**. The airflow into the first stage separator **1070** is tangential which causes a vortex-type, cyclonic or swirling flow. Such vortex flow is directed downwardly in the first stage separator by a bottom guide plate **1092** of the air manifold **1042**. Cyclonic action in the first stage separator removes a substantial portion of the entrained dust and dirt from the suction air stream and causes the dust and dirt to be deposited in the first dust collection chamber **1052** of the dirt cup **1050**.

[00110] With reference to FIGURES 32-34, operably secured to the cyclone main body **1040** is a first bottom plate or lid **1100**, which allows for emptying of the first dust collection chamber **1052**. The first lid **1100** pivotally and sealingly engages a lower portion of the wall **1102** of the first dust collection chamber **1052**. A seal ring **1104** can be fitted around the first bottom lid to create a seal between the first lid and the dirt cup. A first hinge assembly **1108** can be used to mount the first bottom lid **1100** to a lower portion of the dirt cup **1050**. The first hinge assembly allows the first bottom lid to be selectively opened so that dirt and dust particles that were separated from the air stream by the first stage separator **1070** can be emptied from the first dust collection chamber **1052**. A first latch assembly **1110**, which can be located diametrically opposed from the first hinge assembly **1108**, normally maintains the first bottom lid **1100** in a closed position. In the depicted embodiment, the first latch assembly includes a first arm **1112**, a biasing member, such as a spring **1114**, and a first projection **1116** located on the wall **1102** and a first latch **1120** located on the

first lid. In use, as the first arm is pushed downwardly, the first arm engages the first latch and moves the first latch off of the first projection allowing the first lid to open.

[00111] Similar to the previous embodiments, fluidly connecting the first cyclone part **1058** to the second cyclone part **1060** is a perforated tube **1130**. The perforated tube is disposed within the first stage separator **1070** and extends longitudinally therein. The perforated tube includes a generally cylindrical section **1132** including a plurality of openings or perforations **1134** located around a portion of the circumference of the cylindrical section. The openings **1134** serve as an outlet from the first stage separator **1070**, allowing the partially cleaned fluid to enter the second cyclone part **1060**.

[00112] Connected to a lower, closed end **1136** of the perforated tube is a shroud **1140** for retarding an upward flow of dirt and dust particles that have fallen below the first stage separator **1070**. A laminar flow member, such as one or more baffles or fins **1142**, is mounted to the closed lower end **1136** of the perforated tube **1130**. At least a portion of the laminar flow member is encircled by the shroud. An upper end or air outlet **1146** of the perforated tube **1130** is in fluid communication with an air inlet section **1150** of the air manifold **1042** positioned above the first stage separator **1070**.

[00113] As shown in FIGURES 32 and 33, the air manifold **1042** includes the bottom guide plate **1092**, the air inlet section **1150** and a top guide plate **1152**. The guide plates form an air passage for directing partially cleaned air from the perforated tube **1130** to the second cyclone part **1060**. A seal ring **1154** can be fitted between the guide plates to create a seal. The top guide plate **1152** is provided under the cover unit **1046** and includes a top wall **1160** and a plurality of discharge guide tubes **1162**. Each of the discharge guide tube has a generally cylindrical shape and projects downward from the top wall. The discharge guide tubes direct the cleaned air exhausted from the second stage separators **1072** into a filter assembly **1164**. Each discharge guide tube can include a laminar flow member to stop the air from circulating within the discharge tube. As shown in FIGURE 32, the laminar flow member is a generally cross-shaped baffle **1166**. However, it should be appreciated that other shapes are also contemplated. The bottom guide plate **1092** is spaced away from the top guide plate **1152** by a generally continuous, peripheral barrier

1170 extending upwardly from a wall **1172**. The barrier and wall **1160** define an air passage from the manifold air inlet section **1150** to the second stage separators **1072**.

[00114] With reference again to FIGURES 32 and 33, the downstream separators **1072** project downwardly from the bottom guide plate **1092**. Each downstream separator includes a dirty air inlet **1180** in fluid communication with the air inlet section **1150**. The air manifold directs a volume of partially cleaned air generally tangentially into the inlet **1180** of each second stage separator **1072**. This causes a vortex-type, cyclonic or swirling flow. Such vortex flow is directed downwardly in the downstream separator since a top end thereof is blocked by the top guide plate **1152**. Each downstream separator includes a dust blocking member **1182** which limits turbulence in the second dust collection chamber **1054** and prevents re-entrainment of dirt that has fallen into the second dust collection chamber into the cleaned air exiting each downstream separator.

[00115] The dirt separated by each downstream separator **1072** is collected in the second dust collection chamber **1054**. With reference again to FIGURES 32-34, operably secured to the cyclone main body **1040** is a second bottom plate or lid **1190**, which allows for emptying of the second dust collection chamber **1054**. The second lid **1190** pivotally and sealingly engages a lower portion of the wall **1192** of the second dust collection chamber **1054**. Again, a seal ring **1194** can be fitted around the second bottom lid to create a seal between the second lid and the dirt cup. A second hinge assembly **1198** can be used to mount the second bottom lid **1190** to a lower portion of the dirt cup **1050**. A second latch assembly **1200** normally maintains the second bottom lid in a closed position. Similar to the first latch assembly, the second latch assembly includes a second arm **1202**, a biasing member, such as a spring **1204**, and a second projection **1206** located on the wall **1192** and a second latch **1210** located on the second lid.

[00116] As with the previous embodiments, the two lids **1100** and **1190** can be interconnected in order that, for example, the second lid **1190** cannot be opened unless the first one has already been opened. Also, the lids **1100** and **1190** can be mounted to the dirt cup **1050** either directly or indirectly. While a single dirt cup, having two dust collection chambers is shown in this embodiment, it should be appreciated that two

separate dirt cups could also be employed. In that case, the dirt cups could be spaced from each other, if so desired.

[00117] As indicated previously, each discharge guide tube **1162** directs the cleaned air exhausted from the second cyclone part **1160** into the filter assembly **1164** housed in the cover unit **1046** before being discharged to an inlet of the electric motor and fan assembly **1006**. As shown in FIGURE 32, the filter assembly includes a lower plenum **1220** and an upper plenum **1222**. The lower plenum collects a flow of cleaned air from the downstream separators **1072** and directs the cleaned air through a two stage filter element **1244** for filtering any remaining fine dust remaining in the airflow exiting the downstream separators. The two stage filter element can be a compound member with a coarse foam layer **1228** and a fine foam layer **1330**, at least partially housed in the lower plenum. Located downstream therefrom can be a pleated filter **1232**, such as a High-Efficiency Particulate Arresting (HEPA) grade filter, housed in the top plenum. A seal ring **1234** can be used to create a seal between the upper and lower plenums. The upper plenum collects a flow of cleaned air from the filters and directs the flow of cleaned air into a cleaned air outlet conduit **1240**, which is in fluid communication with the inlet of the electric motor and fan assembly.

[00118] With reference again to FIGURES 30-32, the cyclone cover unit **1046** includes a bottom housing **1250** and a top housing **1252** having a handle **1254**. The two stage filter element **1224** and the pleated filter **1232** can both be easily serviced by removing the top housing from the bottom housing. For example, the top housing can be pivotally mounted to the bottom housing. A push button latch assembly **1260** can be operably mounted to cover unit for releasably locking the top housing to the bottom housing. The bottom housing is configured to cover an upper portion of both the first and second cyclone parts **1058** and **1060**.

[00119] As to a further discussion of the structure, manner of usage and operation of the seventh embodiment, the same should be apparent from the above description relative to the first embodiment. Accordingly, no further discussion relating to the manner of usage and operation will be provided.

[00120] The present invention has been described with reference to the several embodiments. Obviously, modifications and alterations will occur to others upon reading and understanding the preceding detailed description. It is intended that the present

invention be construed as including all such modifications and alterations insofar as they come within the scope of the appended claims or the equivalents thereof.

What we claim is:

1. A home cleaning appliance comprising:
 - a housing comprising a nozzle, including a main suction opening and a brush;
 - an air stream suction source, mounted to said housing and including a suction airstream inlet and a suction airstream outlet, said suction source selectively establishing and maintaining a suction airstream from said nozzle main suction opening to said airstream outlet;
 - a cyclone main body, mounted to said housing and in communication with said nozzle main suction opening, said cyclone main body including:
 - an upstream, first, cyclonic separator for separating dust from dust-laden air, and
 - at least one downstream, second, cyclonic separator for separating remaining dust particles from the air; and
 - a dirt cup connected to said cyclone main body, said dirt cup including:
 - a first particle collector communicating with said first separator for collecting dust particles separated by said first separator, and
 - a second particle collector communicating with said at least one second separator for collecting dust particles separated by said at least one second separator, wherein said first particle collector and said second particle collector are configured to empty independently of each other.
2. The appliance of claim 1, further comprising:
 - a first closure member operably secured to said cyclone main body for emptying of said first particle collector, and
 - a second closure member operably secured to said cyclone main body for emptying of said second particle collector.
3. The appliance of claim 2, wherein at least one of said first particle collector and said second particle collector can be selectively detached from said dirt cup.

4. The appliance of claim 1, wherein at least one of said first separator and said at least one second separator is selectively detachable from said housing.

5. The appliance of claim 4, wherein at least one of said first particle collector and said second particle collector is selectively detachable from said dirt cup.

6. The appliance of claim 1, wherein said cyclone main body is selectively detachable from said housing and wherein at least one of said first particle collector and said second particle collector is selectively detachable from said cyclone main body.

7. The appliance of claim 1, wherein said second particle collector includes an upper collection section in communication with a lower collection section, said upper collection section generally surrounding an upper portion of said first separator, a bottom portion of said upper collection section being tapered to promote sliding and transferring of remaining dust particles separated by said at least one second separator from said upper collection section into said lower collection section.

8. The appliance of claim 1, further comprising:
a perforated tube extending along a longitudinal axis of said first separator,
and
an air manifold disposed above said cyclone main body, said perforated tube and said air manifold fluidly connecting said first separator to said at least one second separator.

9. The appliance of claim 8, wherein said perforated tube includes at least one internally mounted fin configured to eliminate cyclonic flow inside said perforated tube.

10. The appliance of claim 9, wherein said air manifold includes an inlet passage in communication with an outlet of said perforated tube, at least one of said inlet passage

and said perforated tube includes a varying cross-sectional area for allowing air stream to be drawn into said perforated tube by way of the venturi effect.

11. The appliance of claim 8, wherein said at least one second separator includes a plurality of cyclonic separators and said manifold includes a plurality of separate air conduits for directing a volume of partially cleaned air generally tangentially into an inlet of each second stage separator.

12. The appliance of claim 1, wherein said first separator includes a dirty air inlet, a top wall and a sidewall having an outer surface and an inner surface, wherein said outer surface of said sidewall forms at least a part of an external surface of said housing.

13. The appliance of claim 1, wherein said at least one second separator includes a dust blocking member which is inclined at an acute angle relative to a longitudinal axis of said at least one second separator.

14. An upright vacuum cleaner comprising:
a nozzle base having a main suction opening;
a housing pivotally mounted on said nozzle base;
an airstream suction source mounted to one of said housing and said nozzle base for selectively establishing and maintaining a suction airstream from said nozzle main suction opening to an exhaust outlet of said suction source; and
a cyclone main body mounted to said housing, said cyclone main body comprising:
a first upstream cyclone part for separating coarse dust from dust-laden air, and
a second downstream cyclone part for separating remaining dust particles from the air;
a first particle collector mounted to said housing and communicating with said first cyclone part for collecting a first portion of dust particles, said first particle

collector including a first closure member operably secured to said first particle collector for emptying said first particle collector; and

a separate second particle collector mounted to said housing and communicating with said second cyclone part for collecting a second portion of dust particles, said second particle collector including a second closure member operably secured to said second particle collector for independent emptying of said second particle collector.

15. The vacuum cleaner of claim 14, wherein at least one of said first particle collector and said second particle collector can be selectively detached from said housing.

16. The vacuum cleaner of claim 14, wherein at least one of said first cyclone part and said second cyclone part can be selectively detached from said cyclone main body.

17. The vacuum cleaner of claim 14, wherein said second cyclone part includes a plurality of cyclonic separators arranged in parallel.

18. A household vacuum cleaner, comprising:
a first housing section including a suction opening, and at least one wheel to allow said first housing section to roll over a subjacent surface;
a second housing section connected to said first housing section;
an airstream suction source mounted to one of said first and second housing sections;
a cyclone main body mounted to said second housing section and including:
an upstream separator stage including an upstream cyclone, and
a downstream separator stage including a plurality of downstream cyclones;
wherein said airstream suction source communicates with said first housing section suction opening via said cyclone main body so that an airstream flows

from said suction opening through said upstream cyclone, said plurality of downstream cyclones and to an inlet of said airstream suction source;

a first particle collector communicating with said upstream cyclone;

and

a second particle collector communicating with said plurality of downstream cyclones, wherein said second particle collector is configured to empty independently of said first particle collector.

19. The vacuum cleaner of claim 18 further comprising a closure member for selectively closing said second particle collector.

20. The vacuum cleaner of claim 19 further comprising a fastening member cooperating with said closure member of said second particle collector to selectively maintain said closure member in a closed position.

21. A home vacuum cleaner including:
a housing in fluid communication with a main suction opening and a brush roll rotatably mounted in said main suction opening;
an airstream suction source mounted to said housing for selectively establishing and maintaining a suction airstream flowing from said main suction opening to an exhaust outlet of said suction source; and
a dirt collector mounted to said housing, said dirt collector comprising:
a first upstream cyclone part for separating dust from dust-laden air,
a second downstream cyclone part for separating remaining dust particles from the air,
a first particle collector communicating with said first cyclone part for collecting dust particles,
a second particle collector communicating with said second cyclone part for collecting dust particles, said first particle separator generally surrounding said second particle collector, wherein said first particle collector and said second

particle collector are configured to independently store and separately empty dirt and dust particles separated by the respective first and second cyclone parts.

22. The vacuum cleaner of claim 21, wherein said second cyclone part includes a plurality of cyclonic separators arranged in parallel.

23. The vacuum cleaner of claim 21, wherein said second particle collector is selectively removable from said dust collector.

24. The vacuum cleaner of claim 21, further including:
a first closure member operably secured to said first particle collector, and
a separate second closure member operably secured to said second particle collector.

25. The vacuum cleaner of claim 24, wherein said first closure member includes a top surface and said second closure member includes a bottom surface, said bottom surface being spaced from said top surface.

26. The vacuum cleaner of claim 24, wherein said first closure member has a diameter which is larger than a diameter of said second closure member.

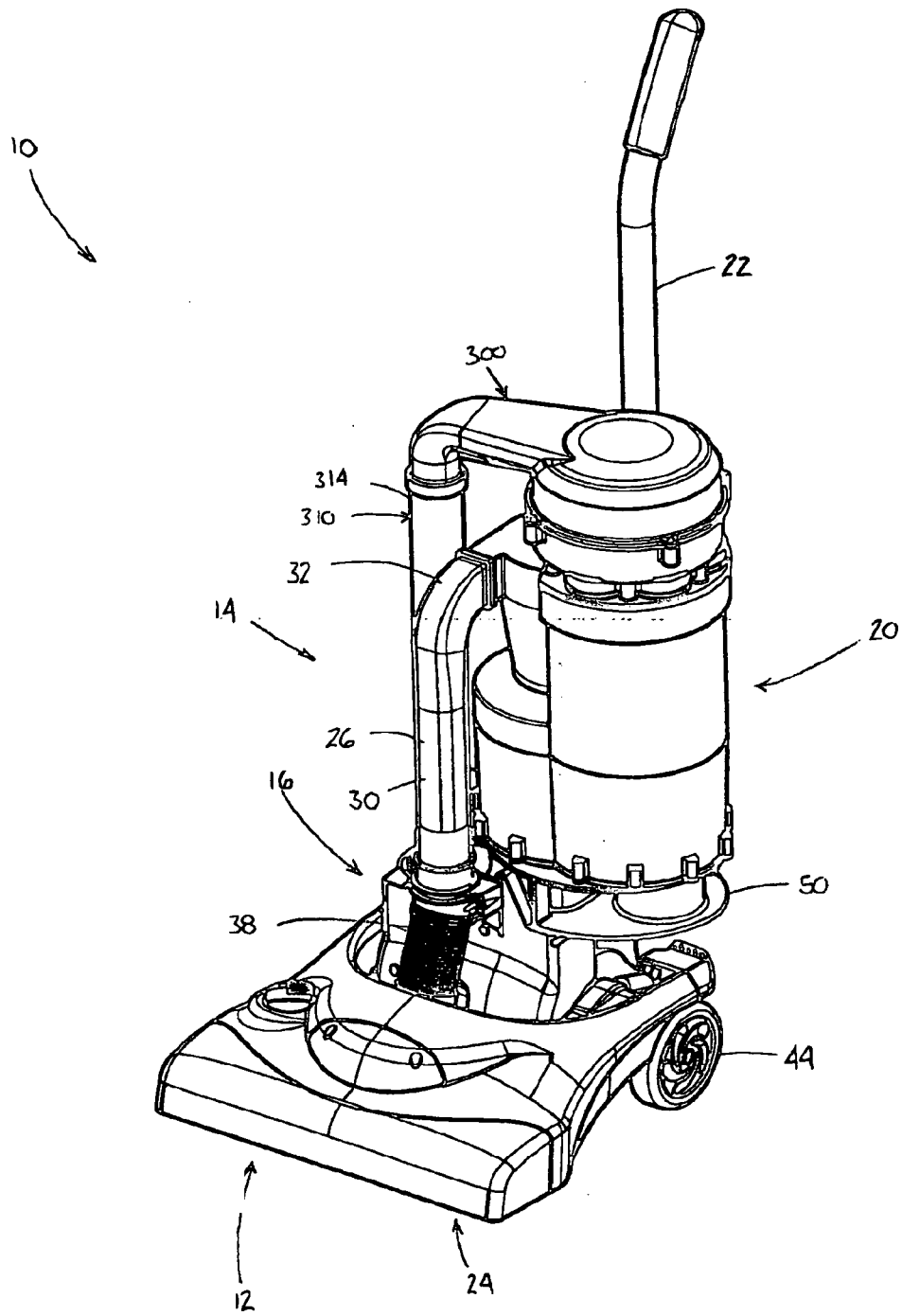

FIGURE 1

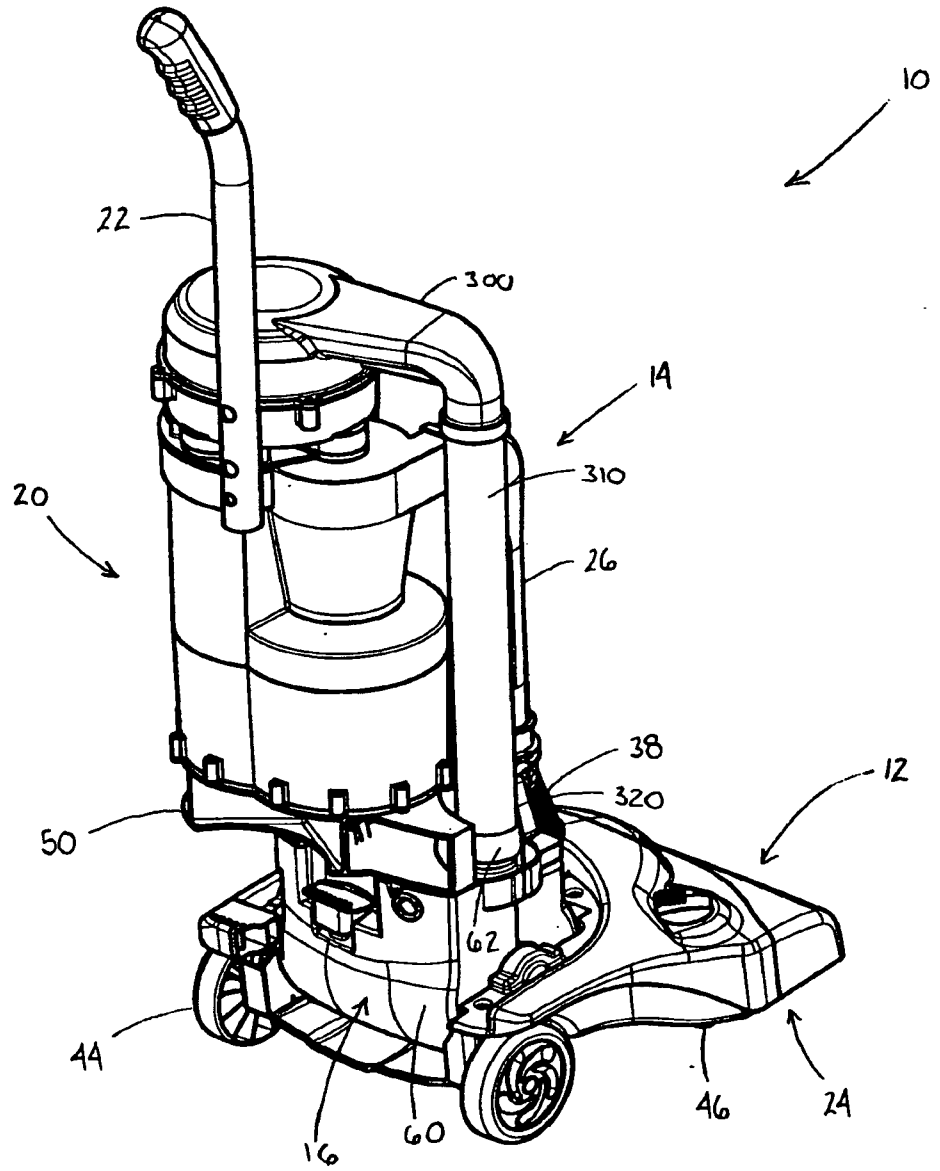

FIGURE 2

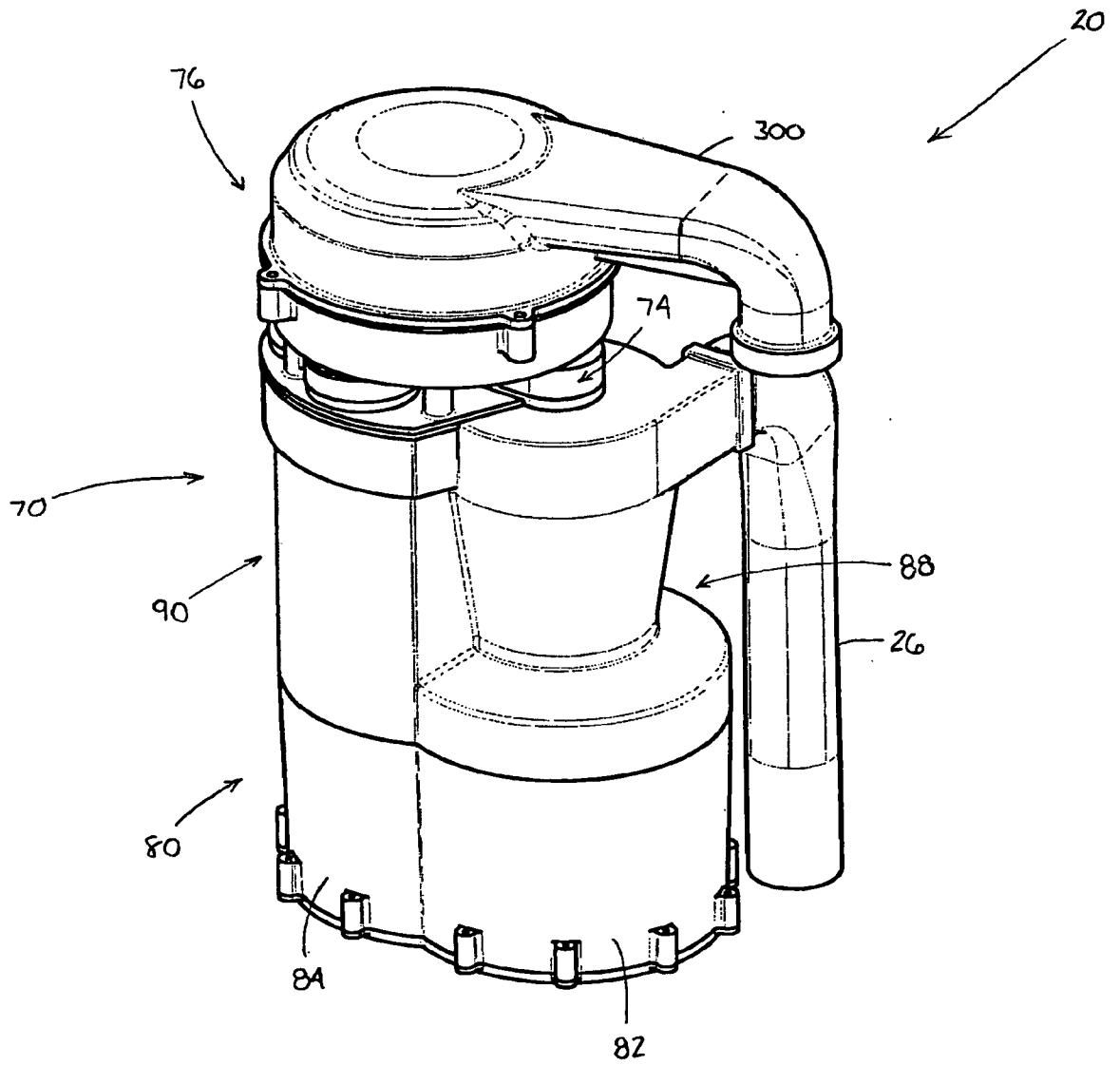

FIGURE 3

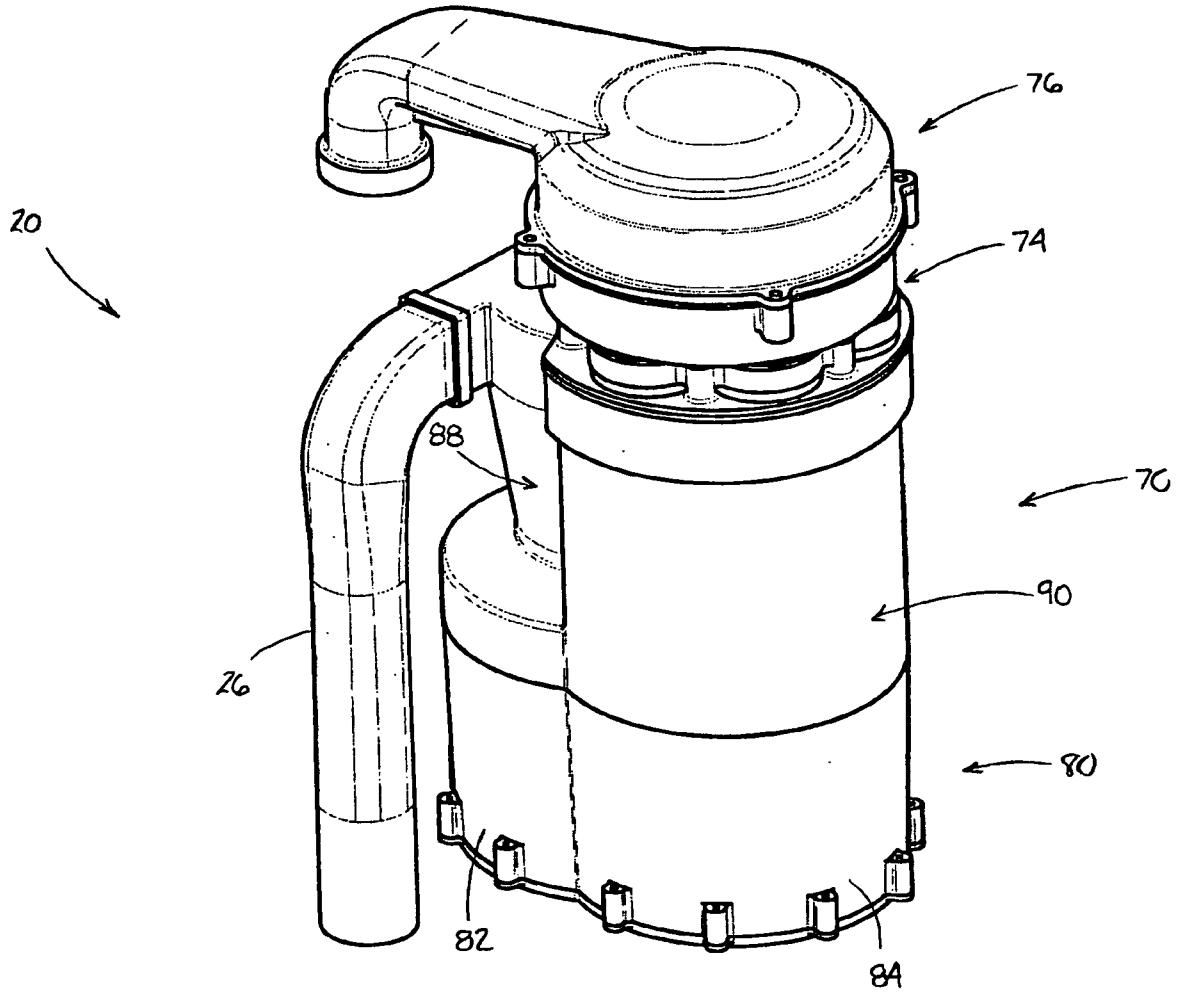

FIGURE A

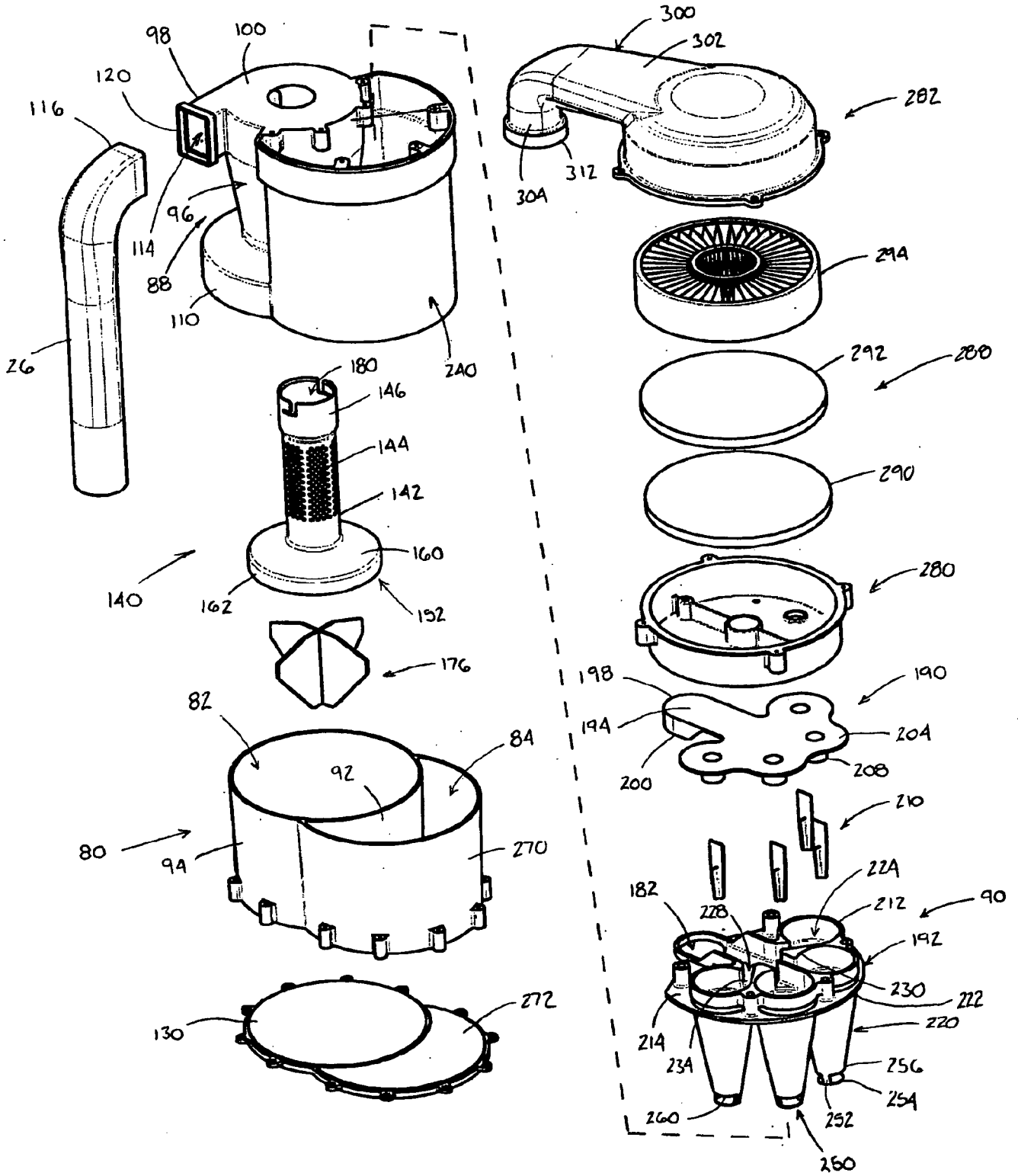

FIGURE 5

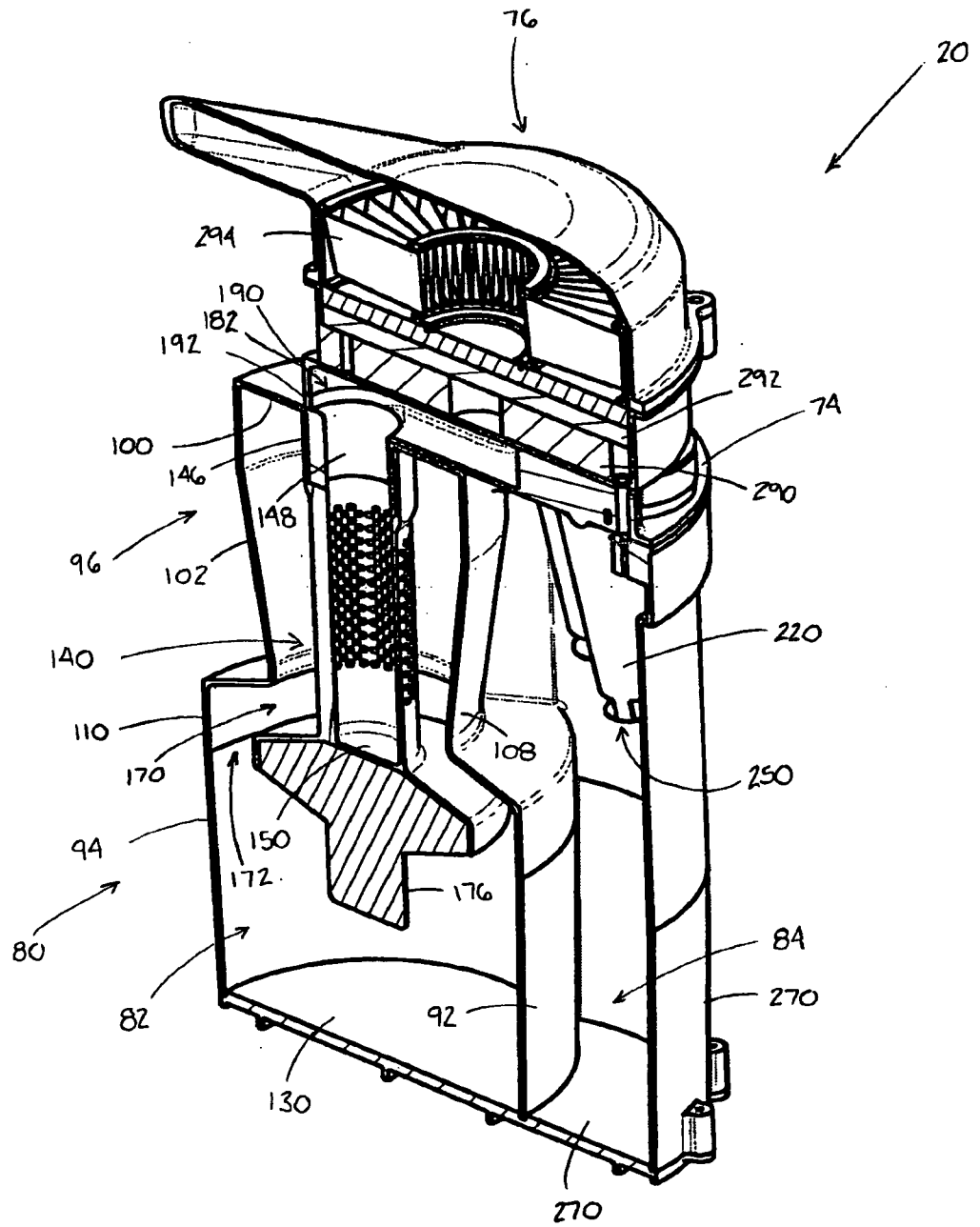

FIGURE 6

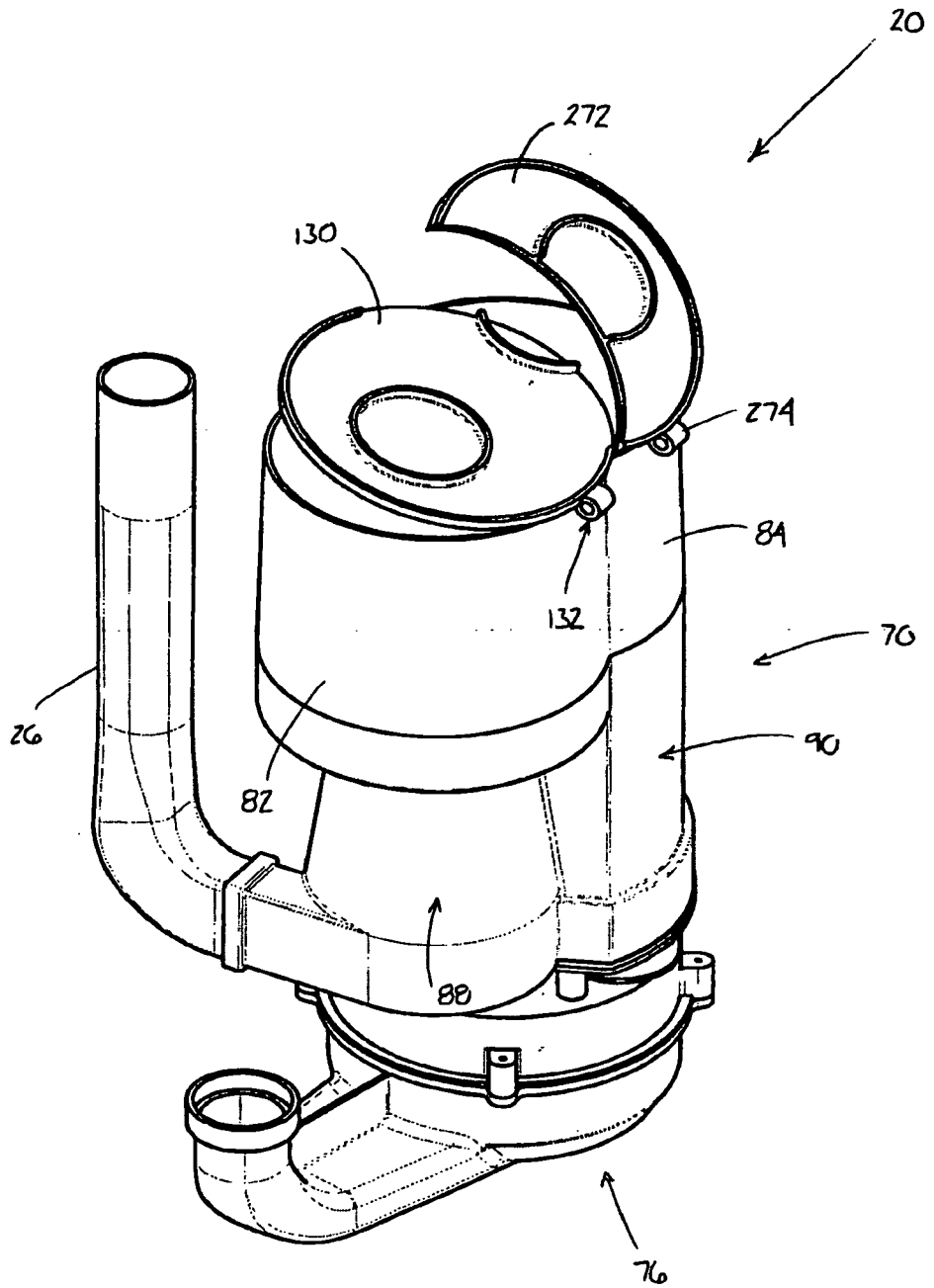

FIGURE 7

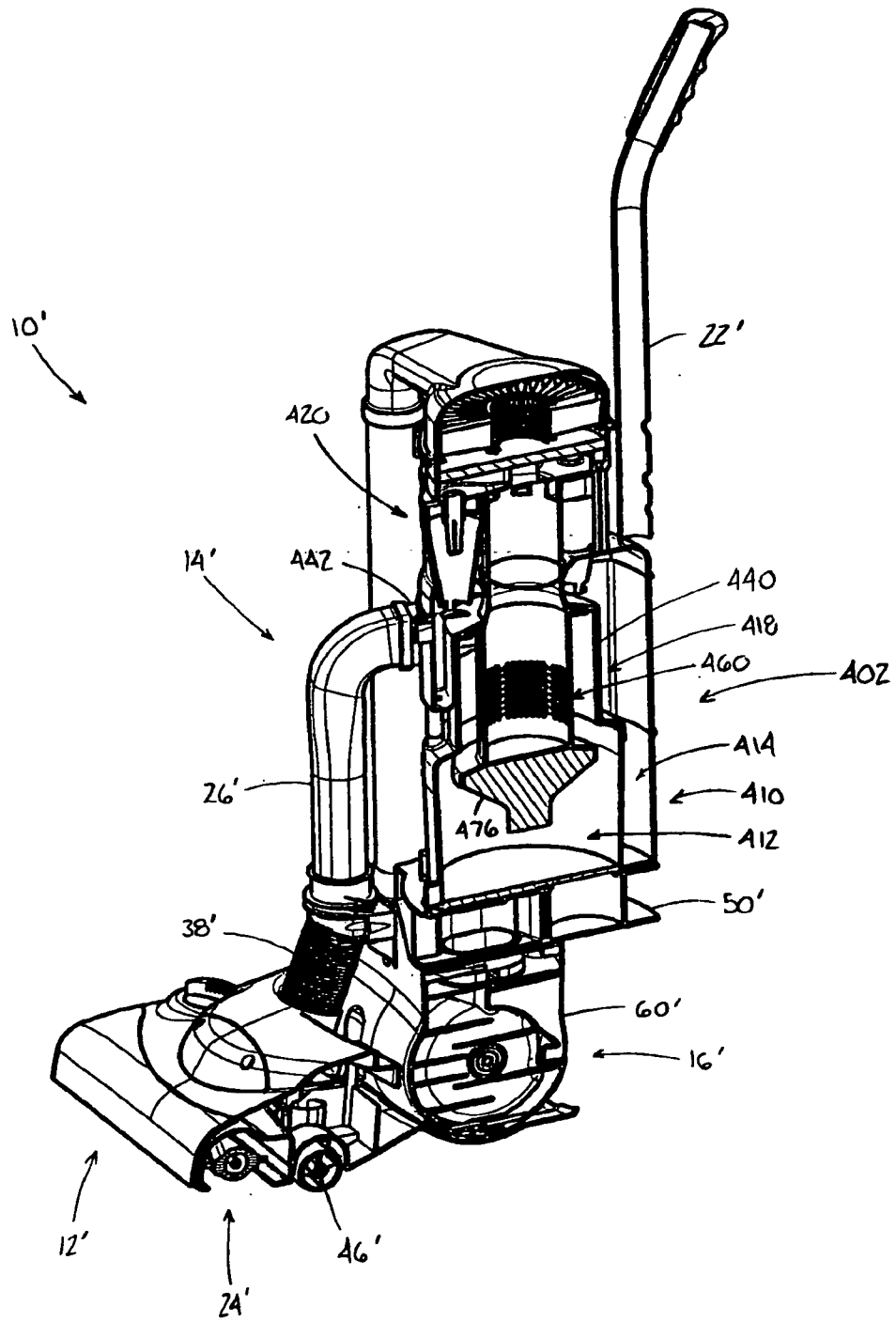

FIGURE 8

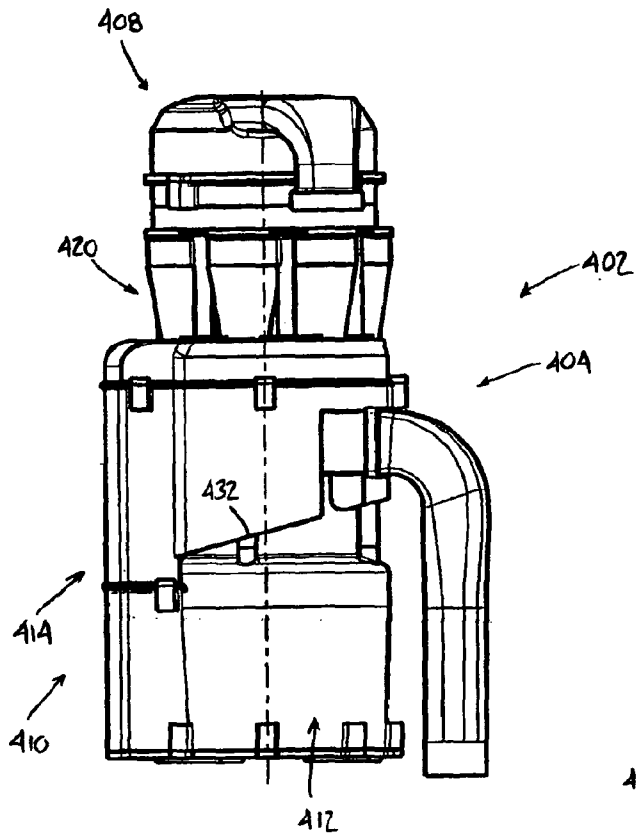

FIGURE 9

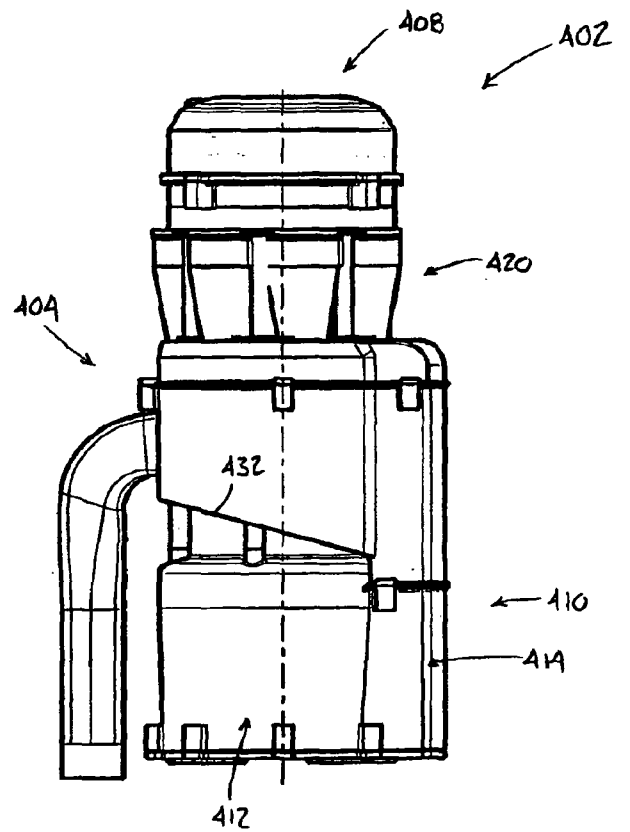

FIGURE 10

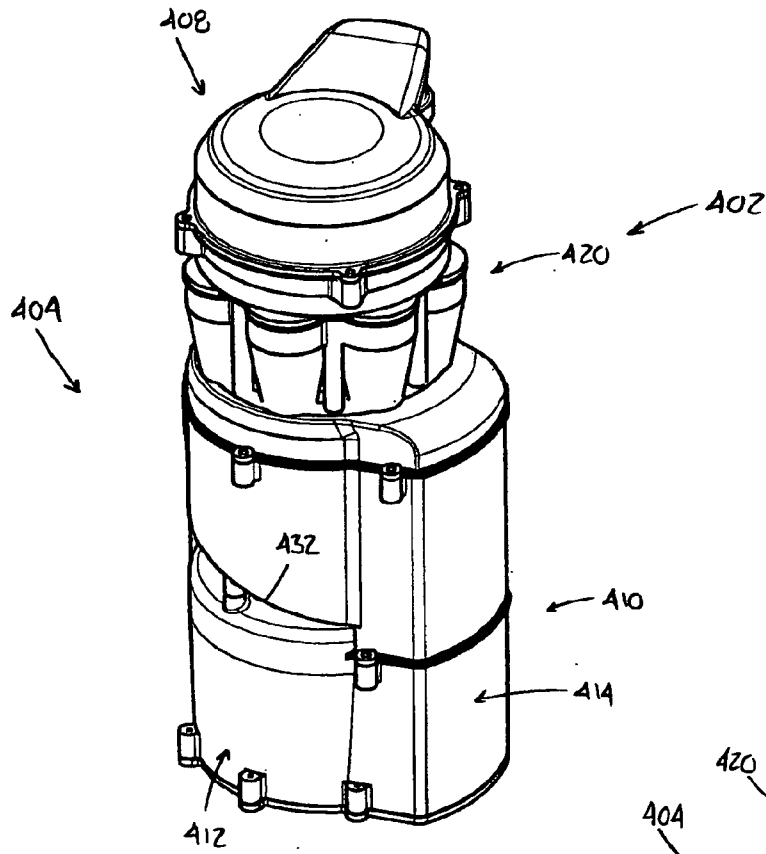

FIGURE 11

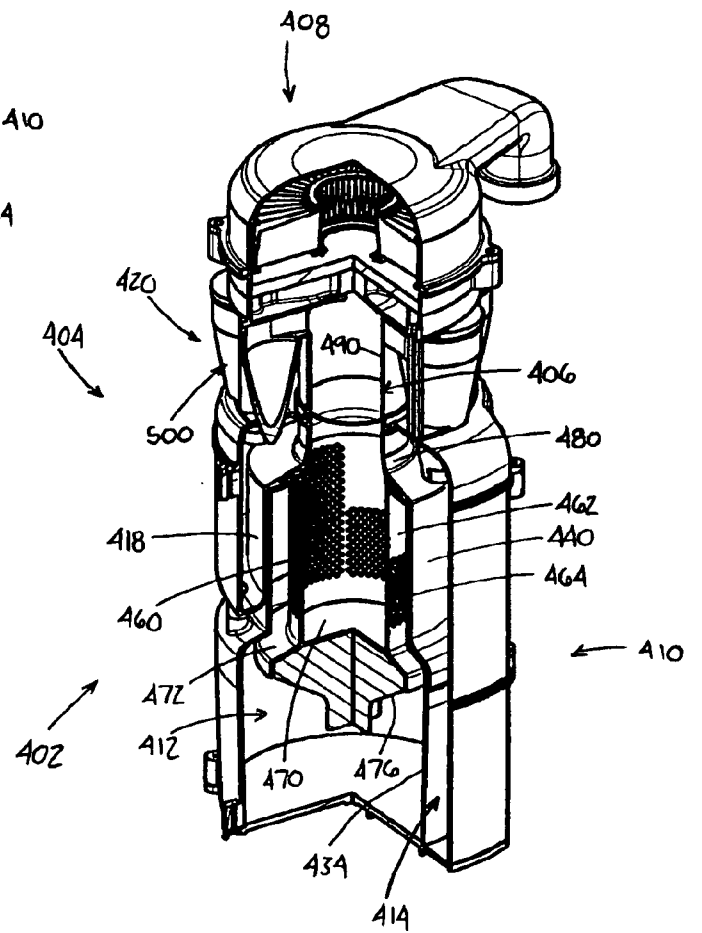

FIGURE 12

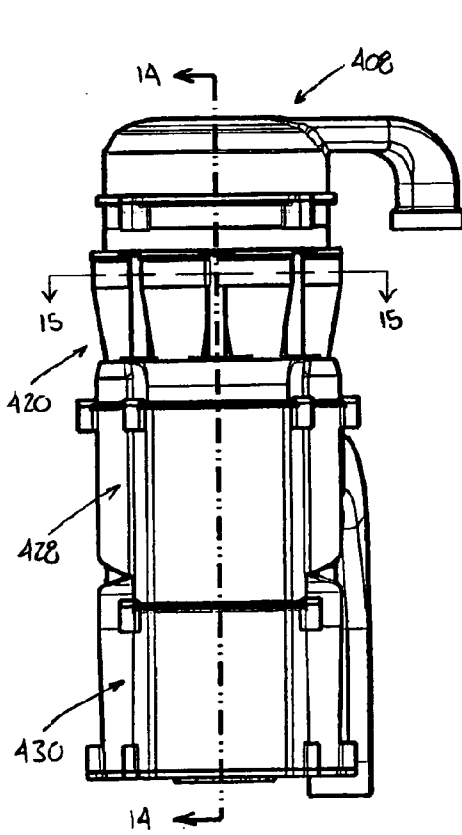
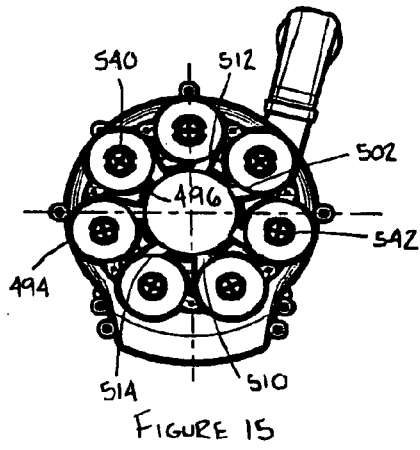

FIGURE 13

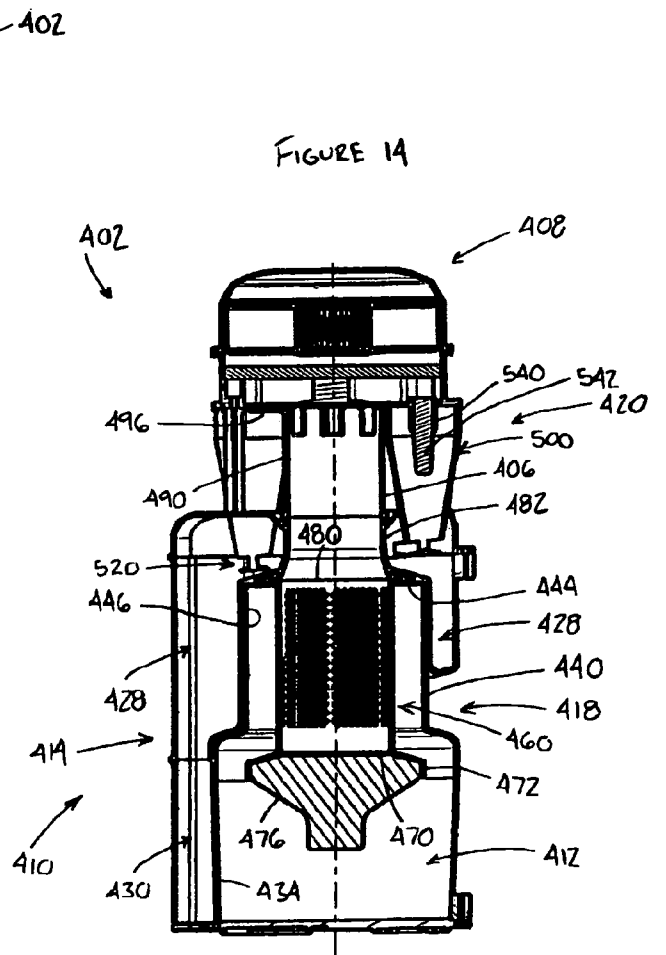
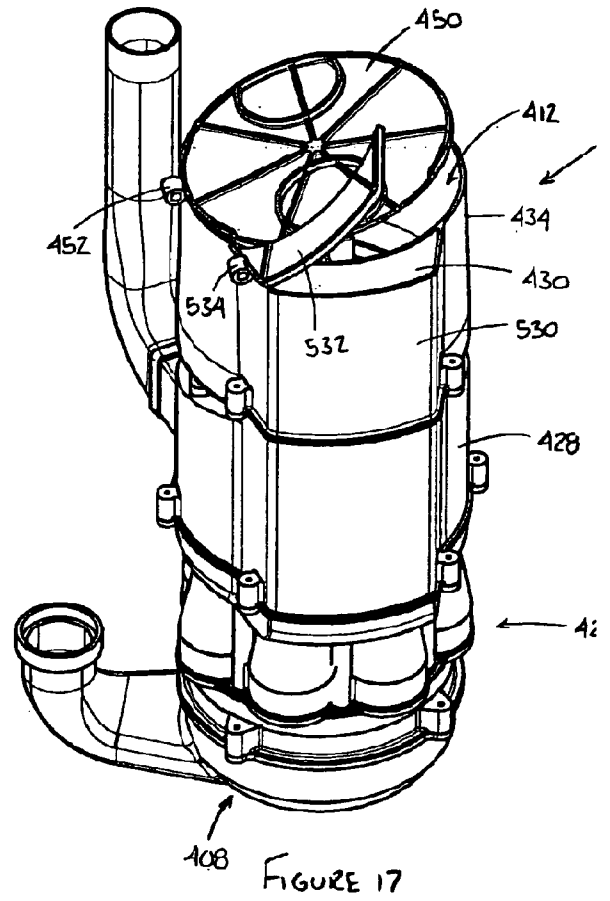
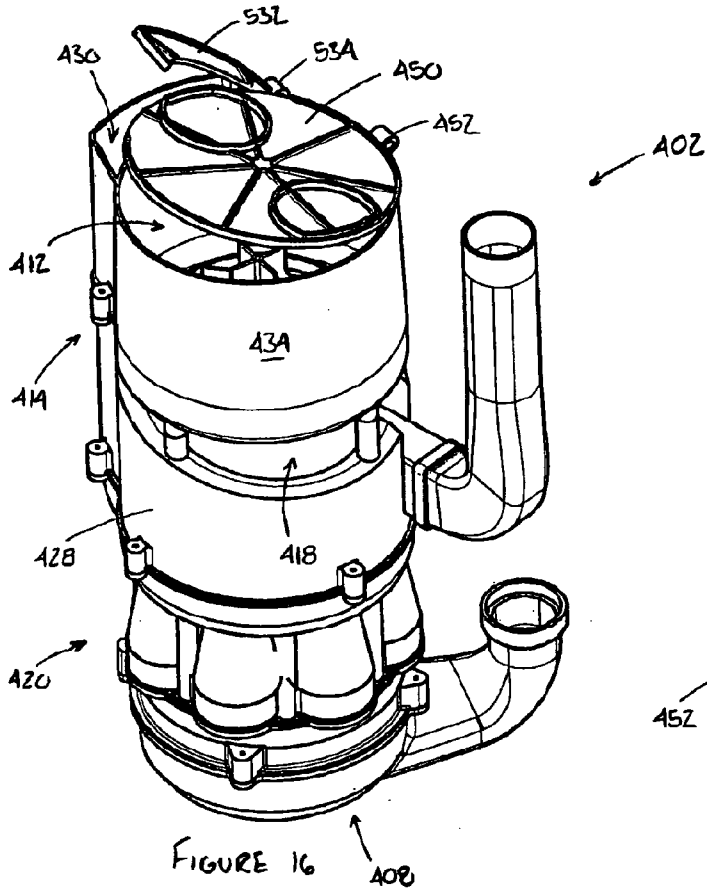

FIGURE 14



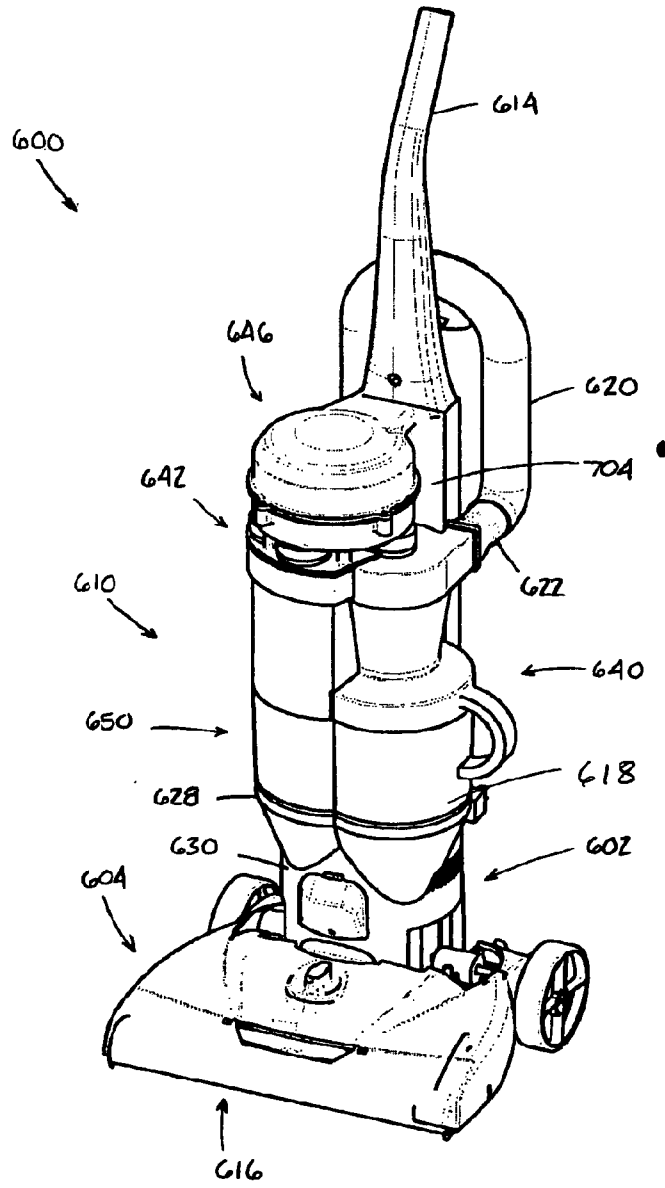

FIGURE 18

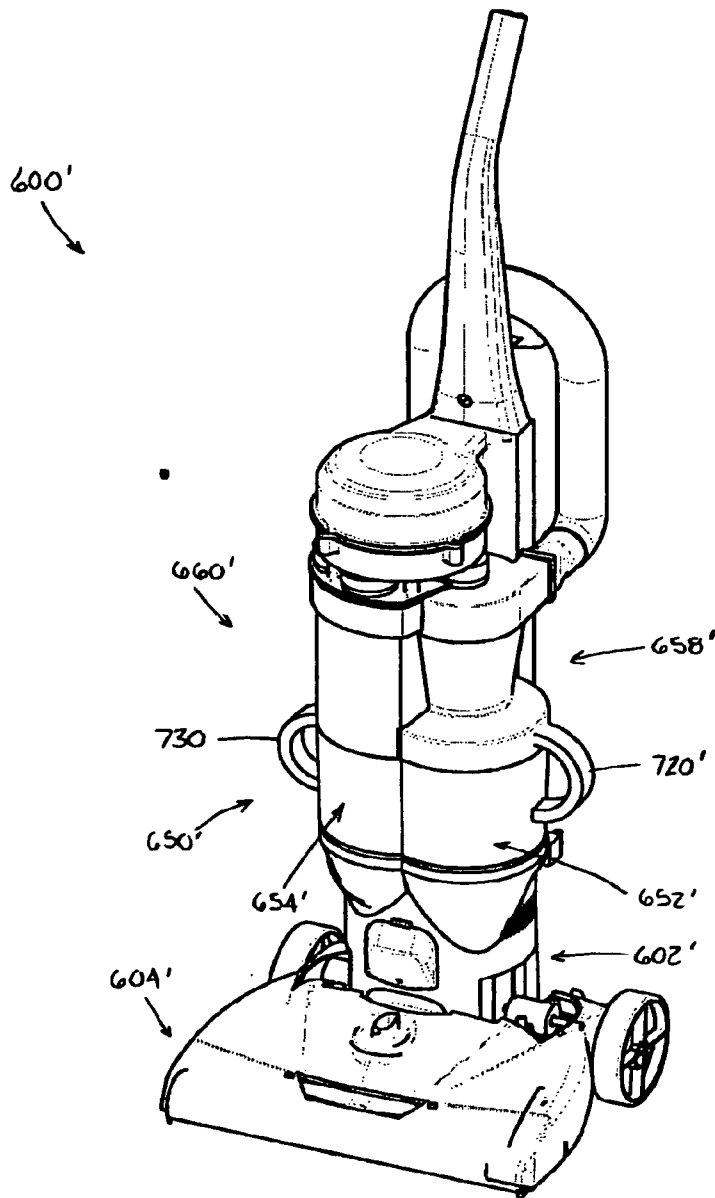

FIGURE 20

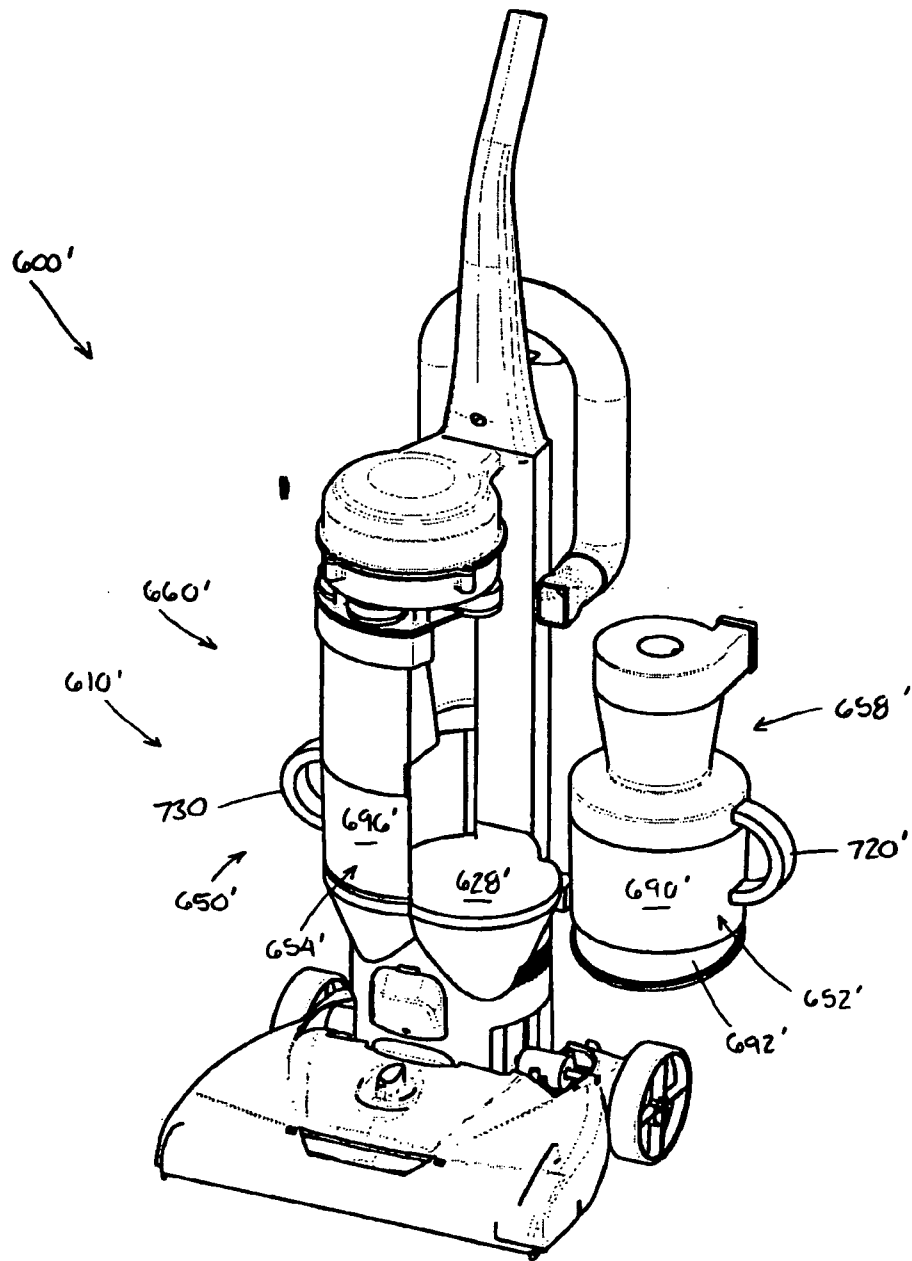

FIGURE 21

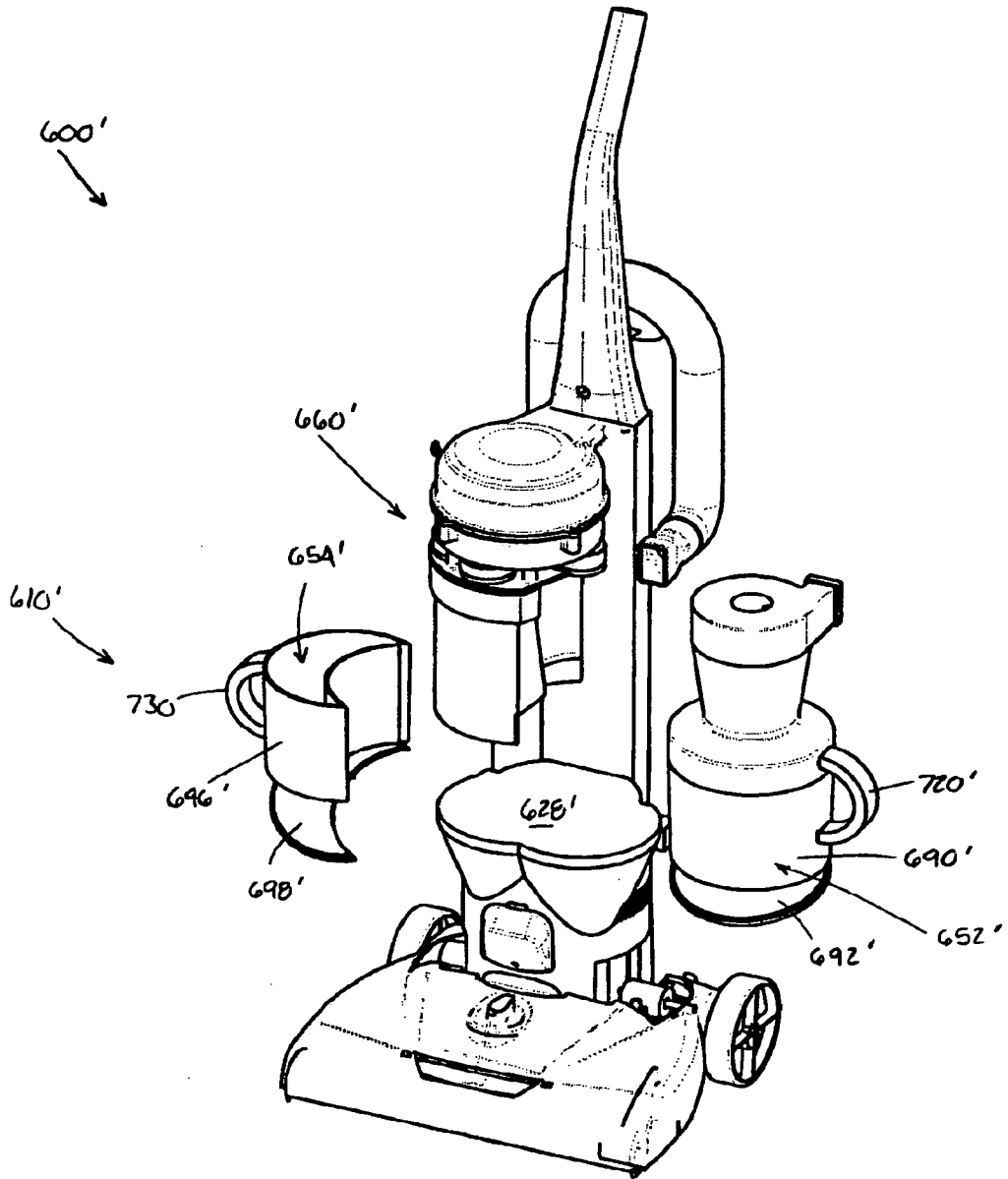

FIGURE 22

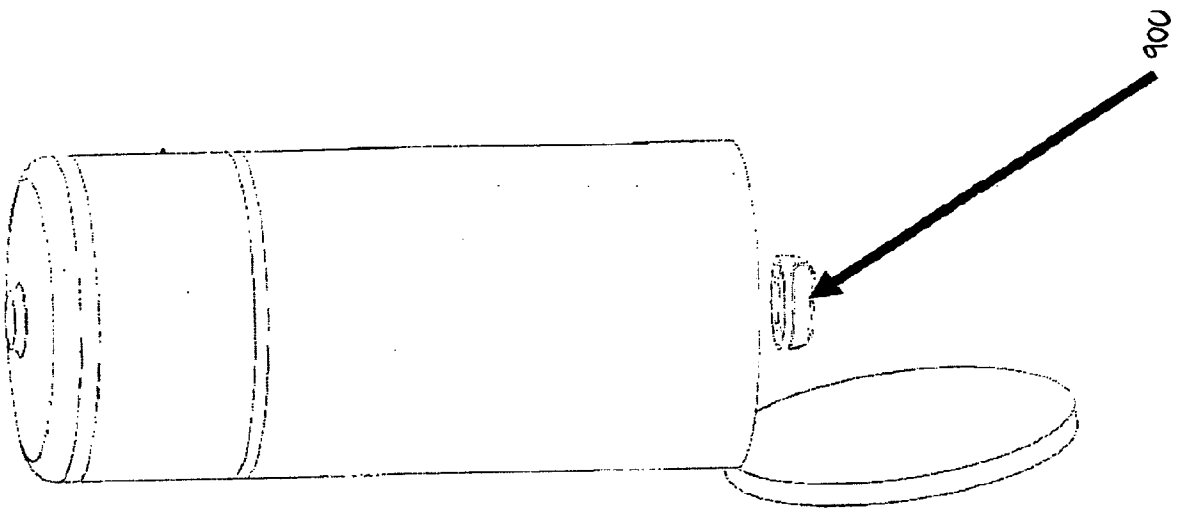
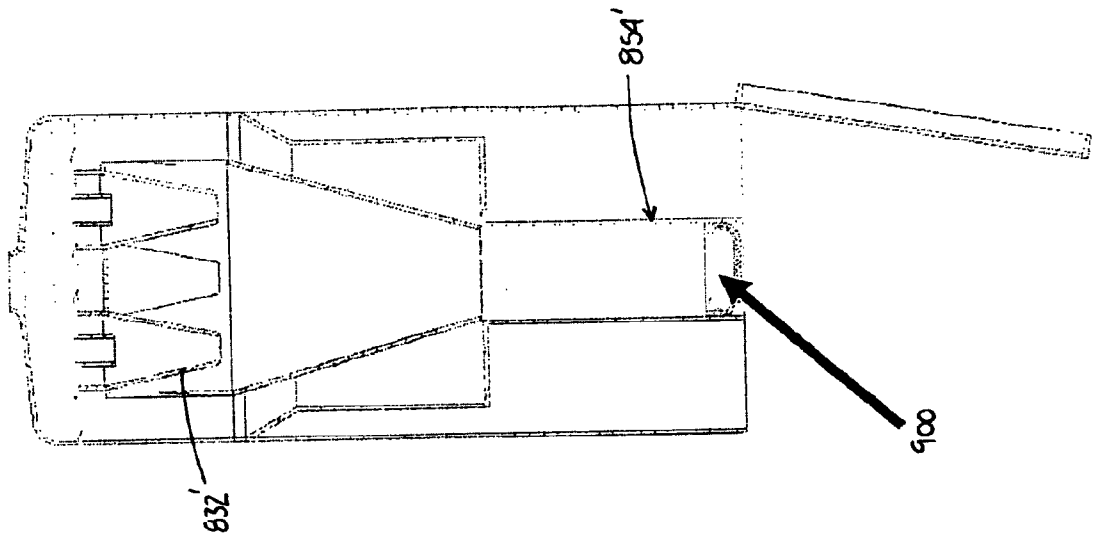

FIGURE 26

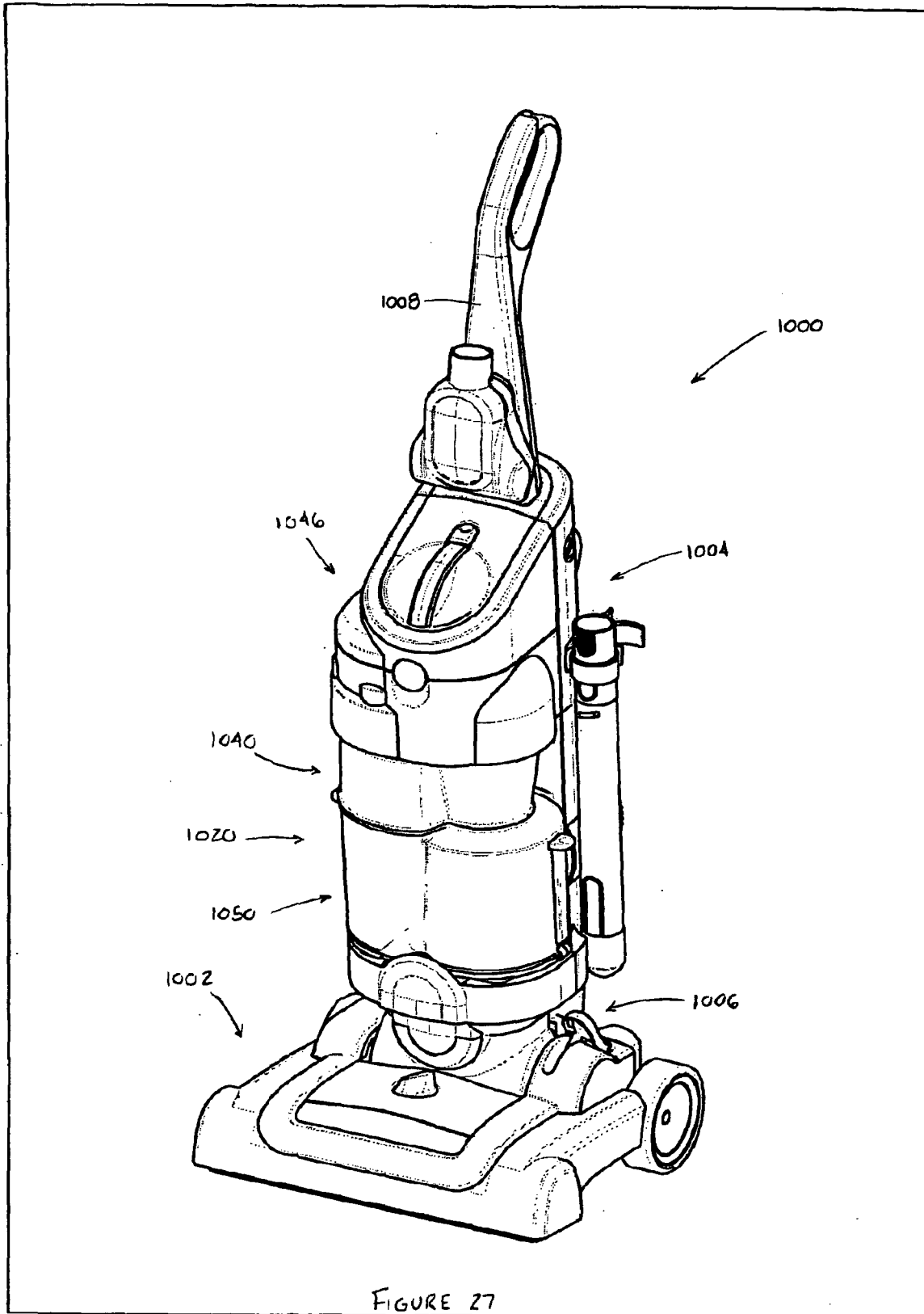

FIGURE 27

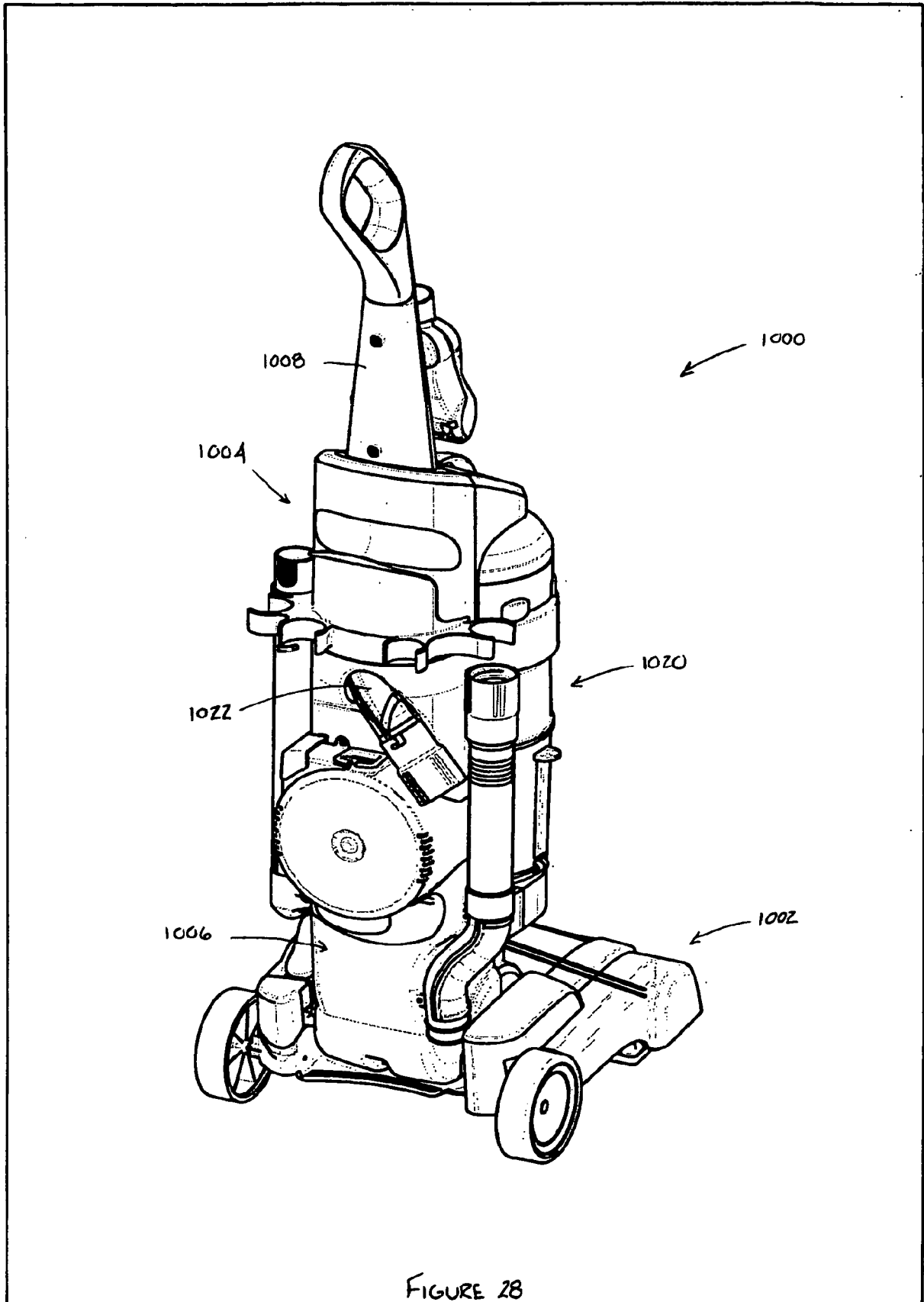
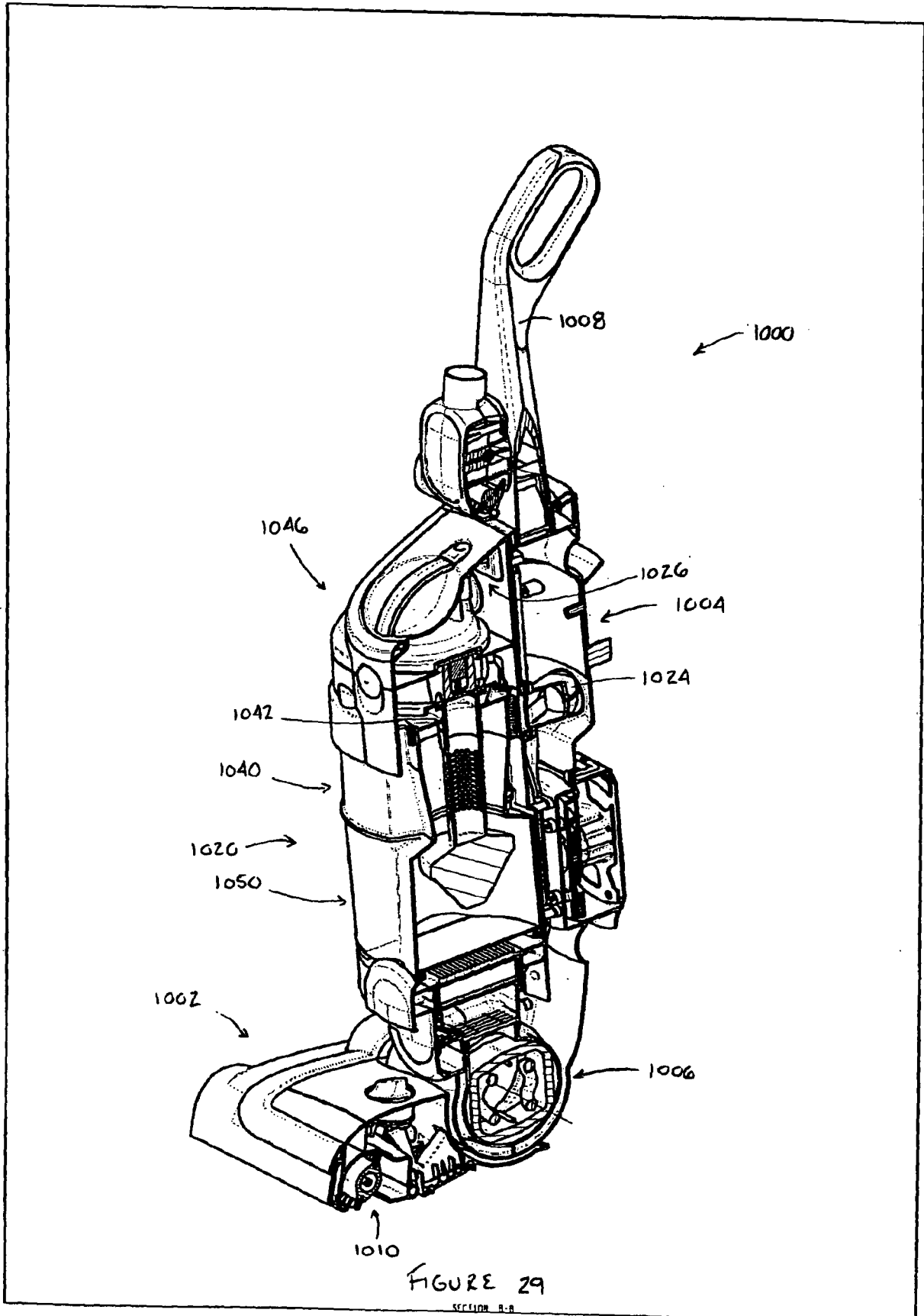

FIGURE 28



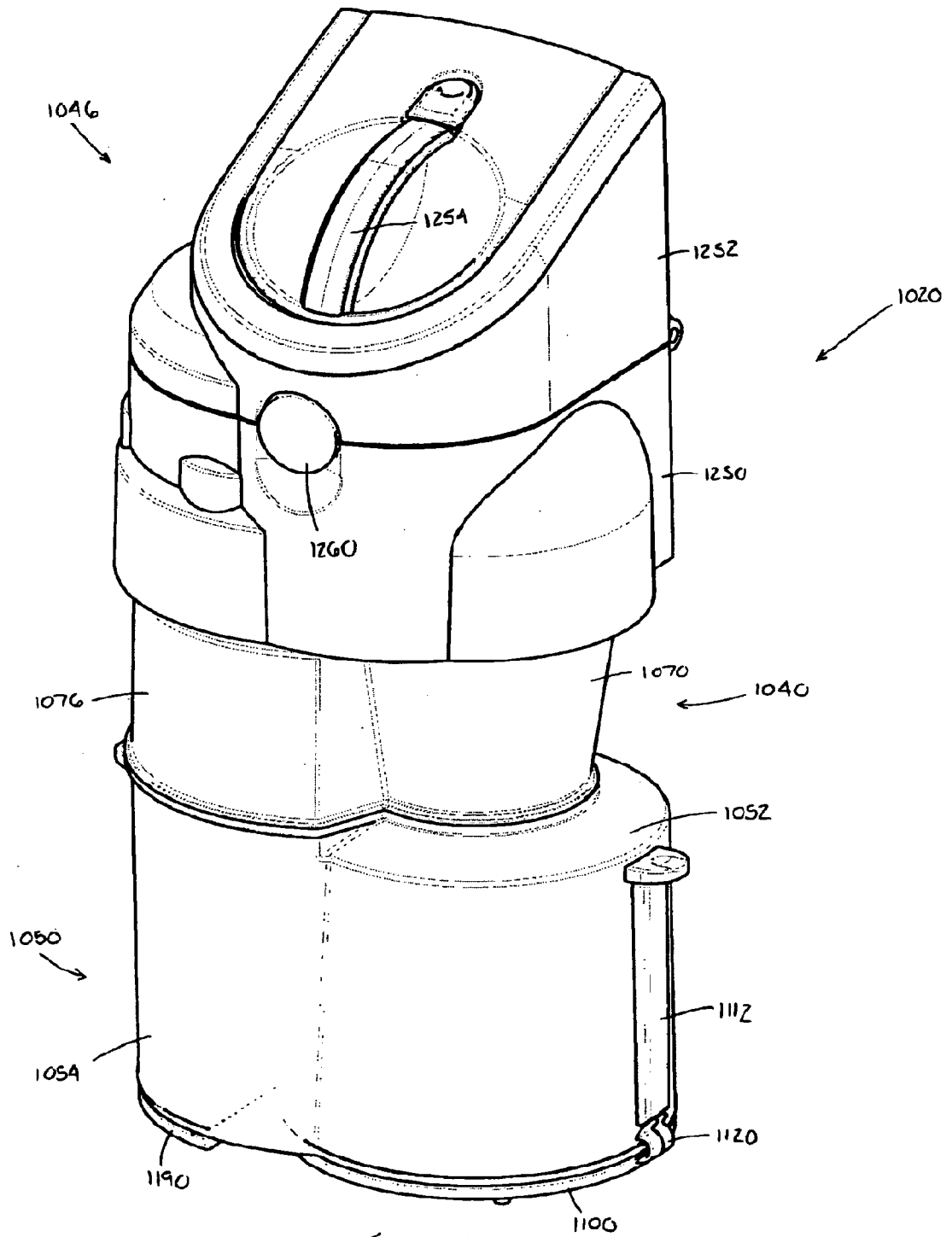

FIGURE 30

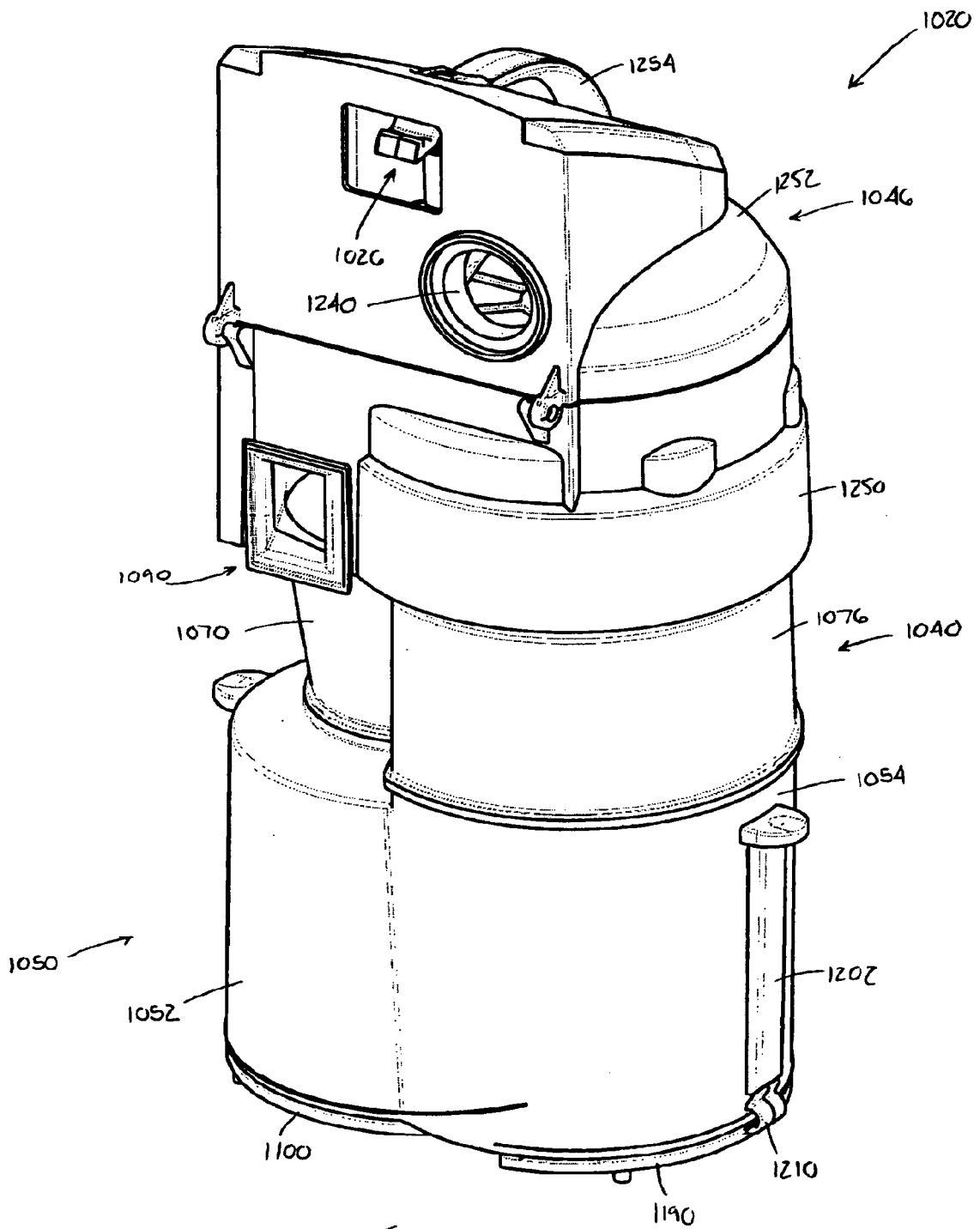
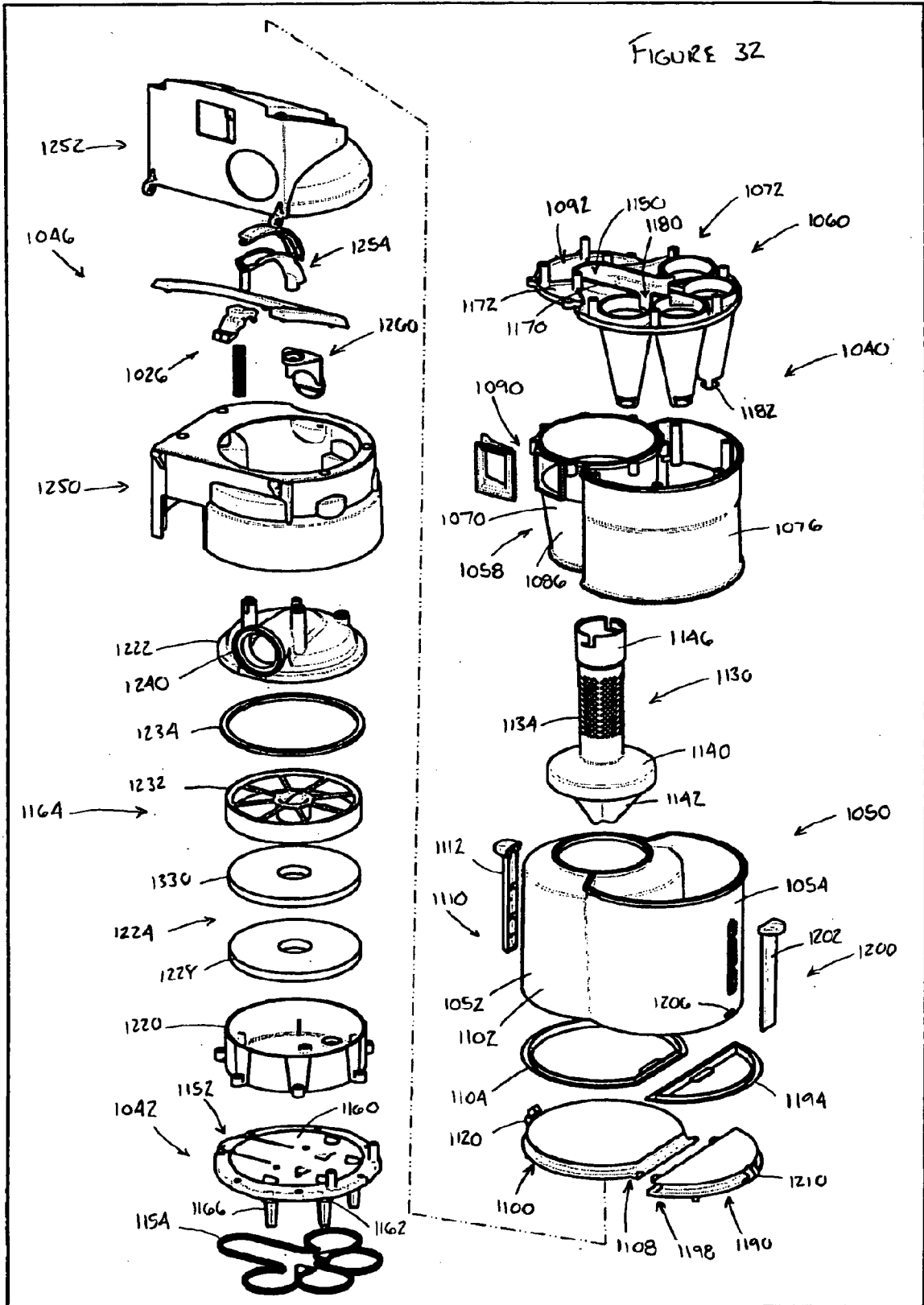

FIGURE 31



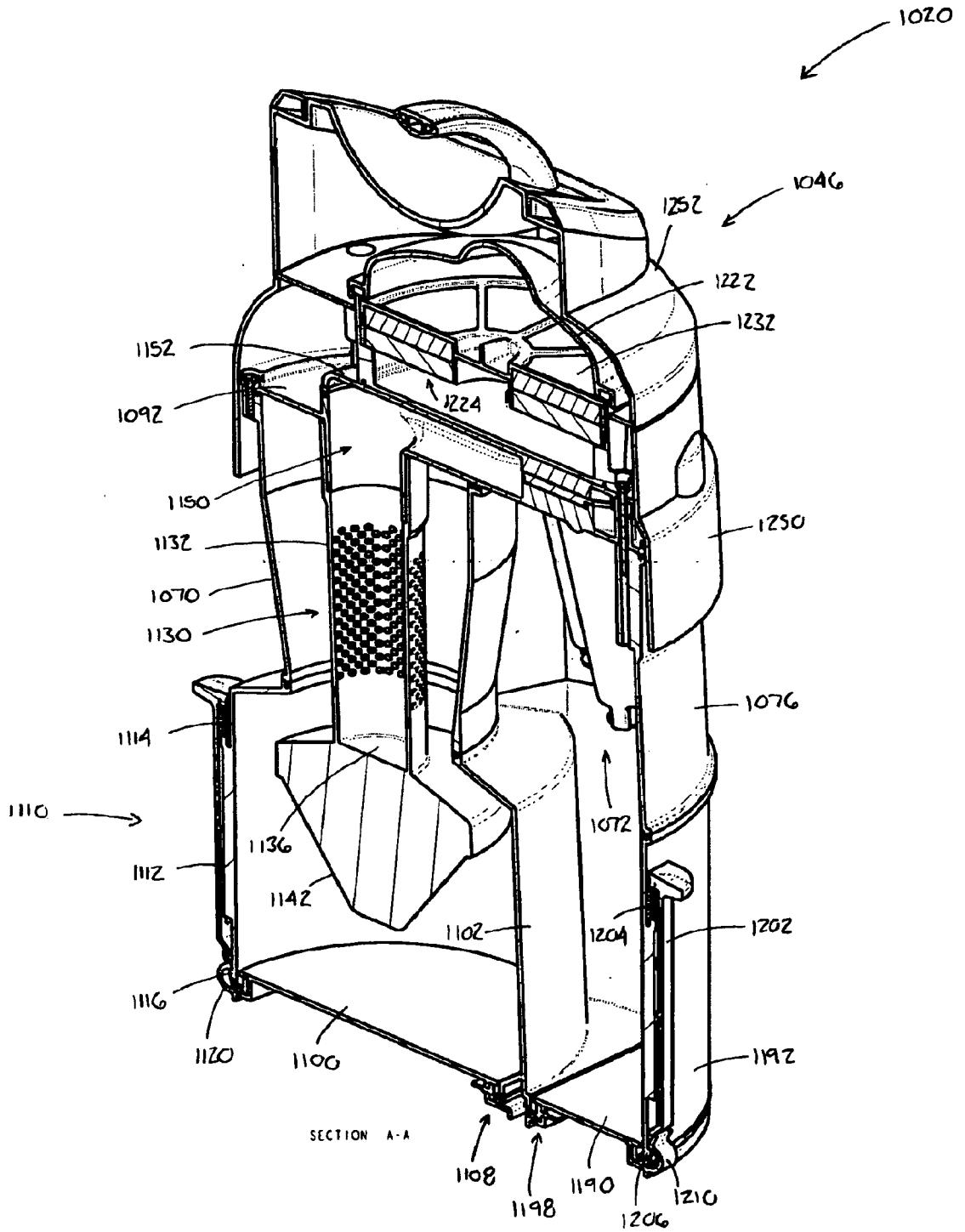

FIGURE 33

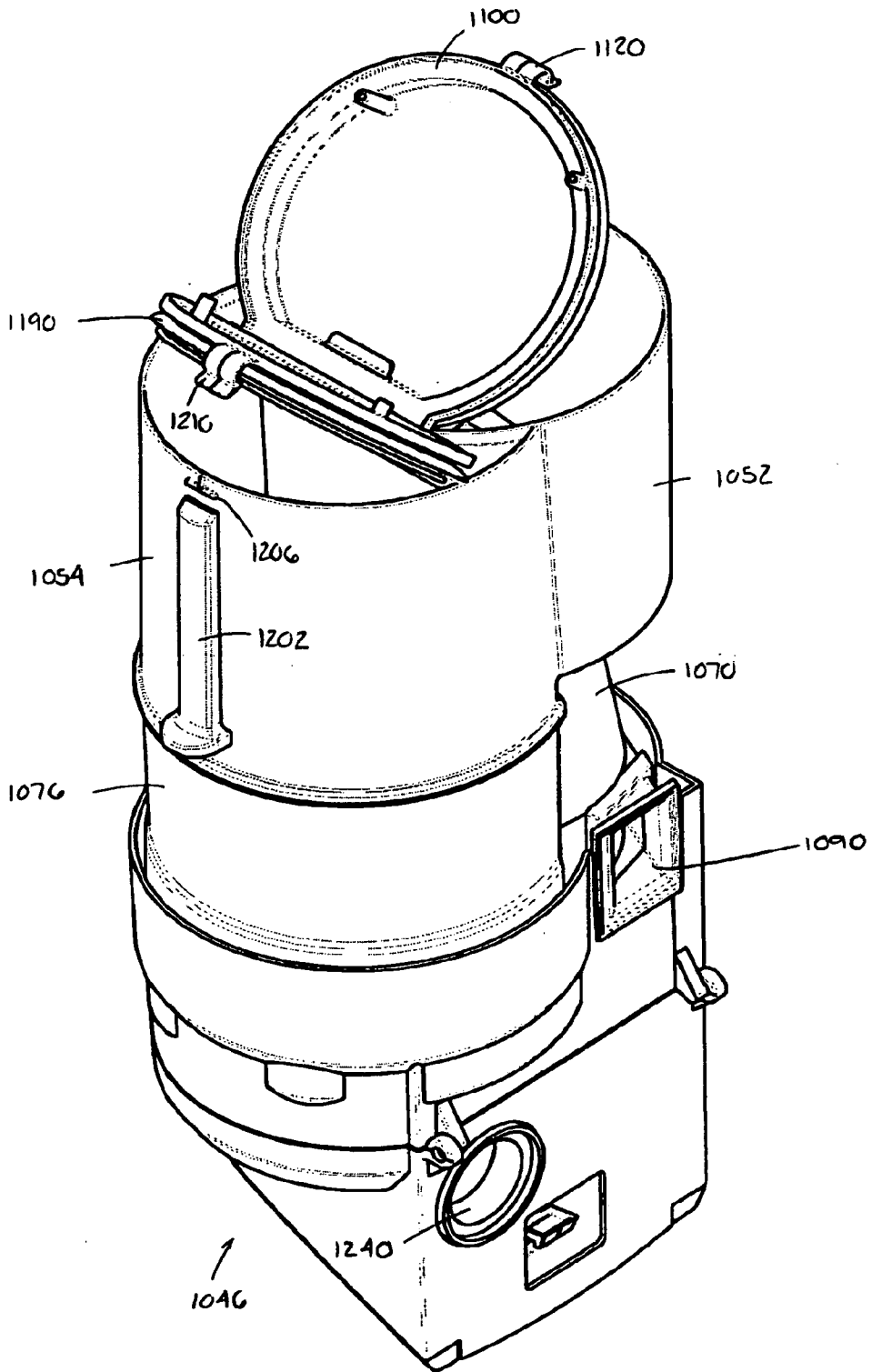

FIGURE 3A