



US 20160211555A9

(19) **United States**
(12) **Patent Application Publication**
Bradwell et al.

(10) **Pub. No.: US 2016/0211555 A9**
(48) **Pub. Date: Jul. 21, 2016**
CORRECTED PUBLICATION

(54) **ELECTROCHEMICAL ENERGY STORAGE DEVICES**

(60) Provisional application No. 61/715,821, filed on Oct. 18, 2012, provisional application No. 61/763,925, filed on Feb. 12, 2013.

(71) Applicant: **Ambri Inc.**, Cambridge, MA (US)

(72) Inventors: **David J. Bradwell**, Arlington, MA (US);
Hari Nayar, Woburn, MA (US)

(21) Appl. No.: **14/688,179**

(22) Filed: **Apr. 16, 2015**

Prior Publication Data

(15) Correction of US 2015/0249273 A1 Sep. 3, 2015
See (63) and (60) Related U.S. Application Data.

(65) US 2015/0249273 A1 Sep. 3, 2015

Related U.S. Application Data

(63) Continuation of application No. PCT/US2013/065092, filed on Oct. 15, 2013, which is a continuation-in-part of application No. 13/801,333, filed on Mar. 13, 2013, now Pat. No. 9,312,522.

Publication Classification

(51) **Int. Cl.**
H01M 10/39 (2006.01)
H01M 4/38 (2006.01)
H01M 10/42 (2006.01)
(52) **U.S. Cl.**
CPC *H01M 10/399* (2013.01); *H01M 10/425* (2013.01); *H01M 4/381* (2013.01); *H01M 4/382* (2013.01); *H01M 4/38* (2013.01); *H01M 2010/4271* (2013.01); *H01M 2220/20* (2013.01)

(57) **ABSTRACT**

Provided herein are energy storage devices. In some cases, the energy storage devices are capable of being transported on a vehicle and storing a large amount of energy. An energy storage device is provided comprising at least one liquid metal electrode, an energy storage capacity of at least about 1 MWh and a response time less than or equal to about 100 milliseconds (ms).

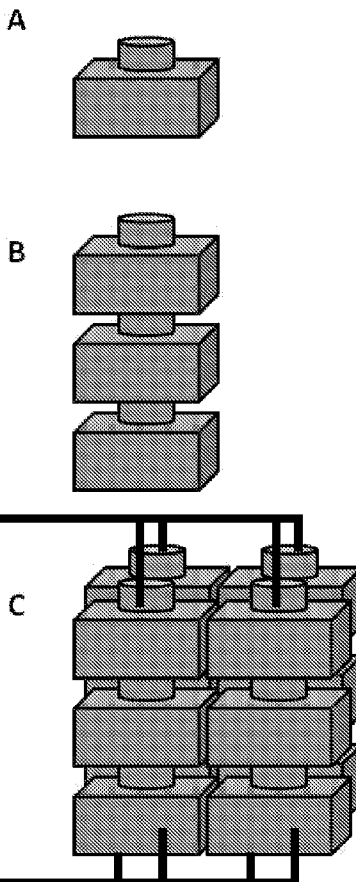

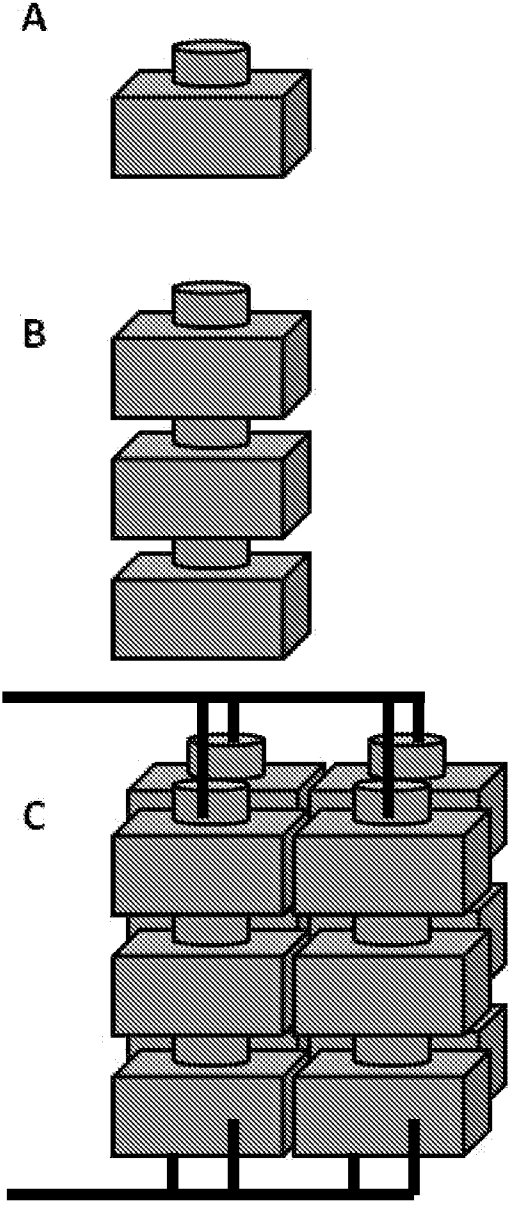

FIG. 1

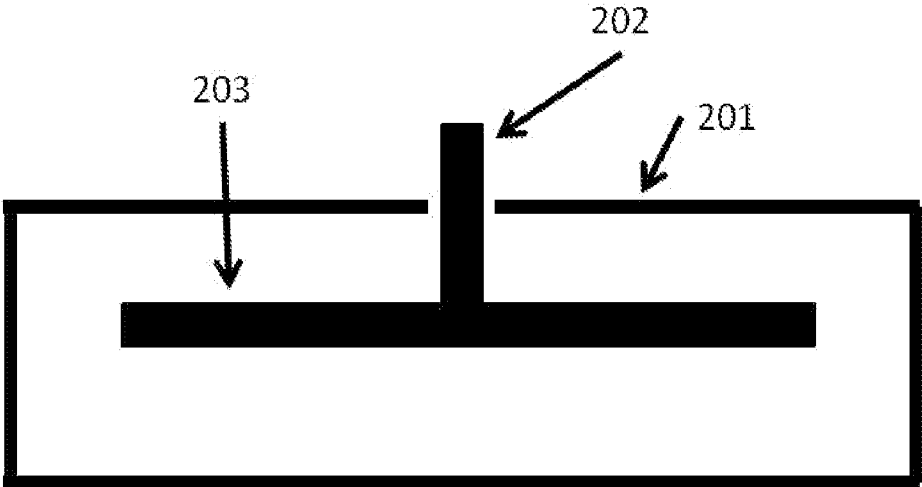

FIG. 2

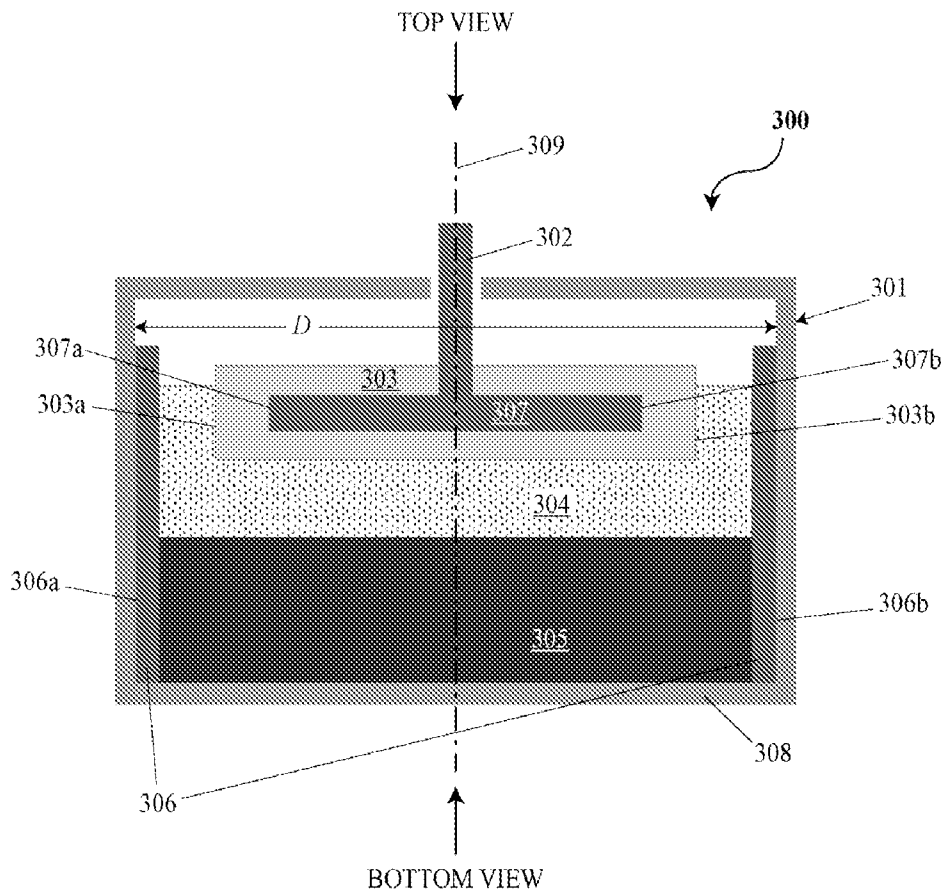

FIG. 3

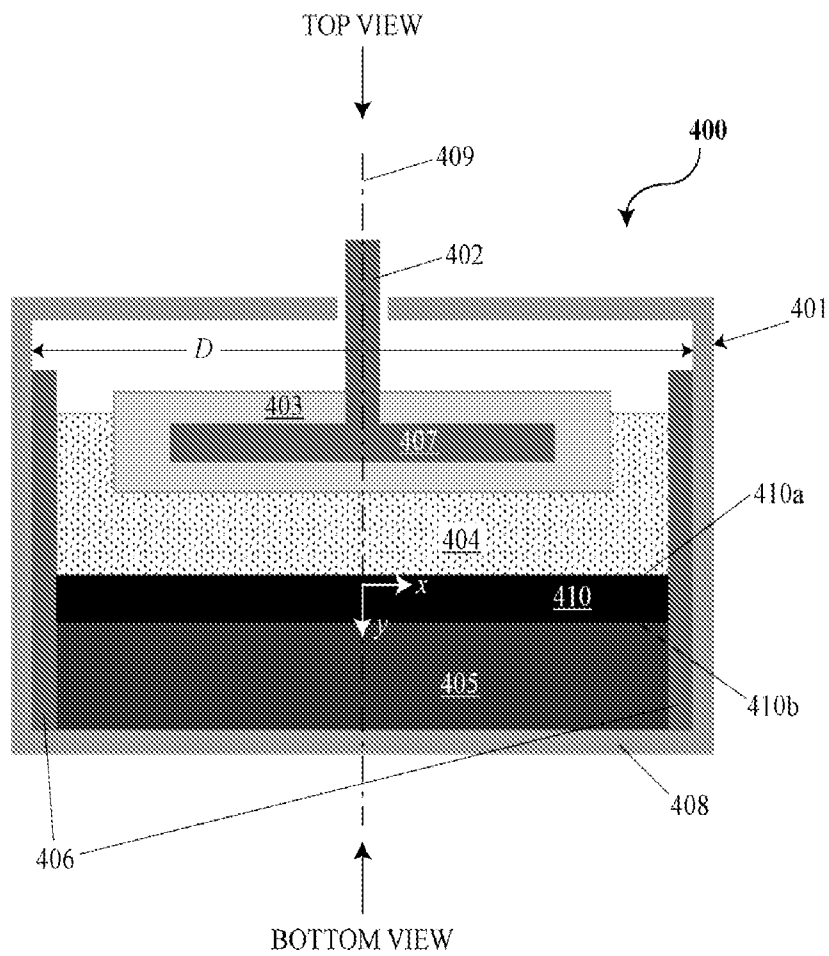

FIG. 4

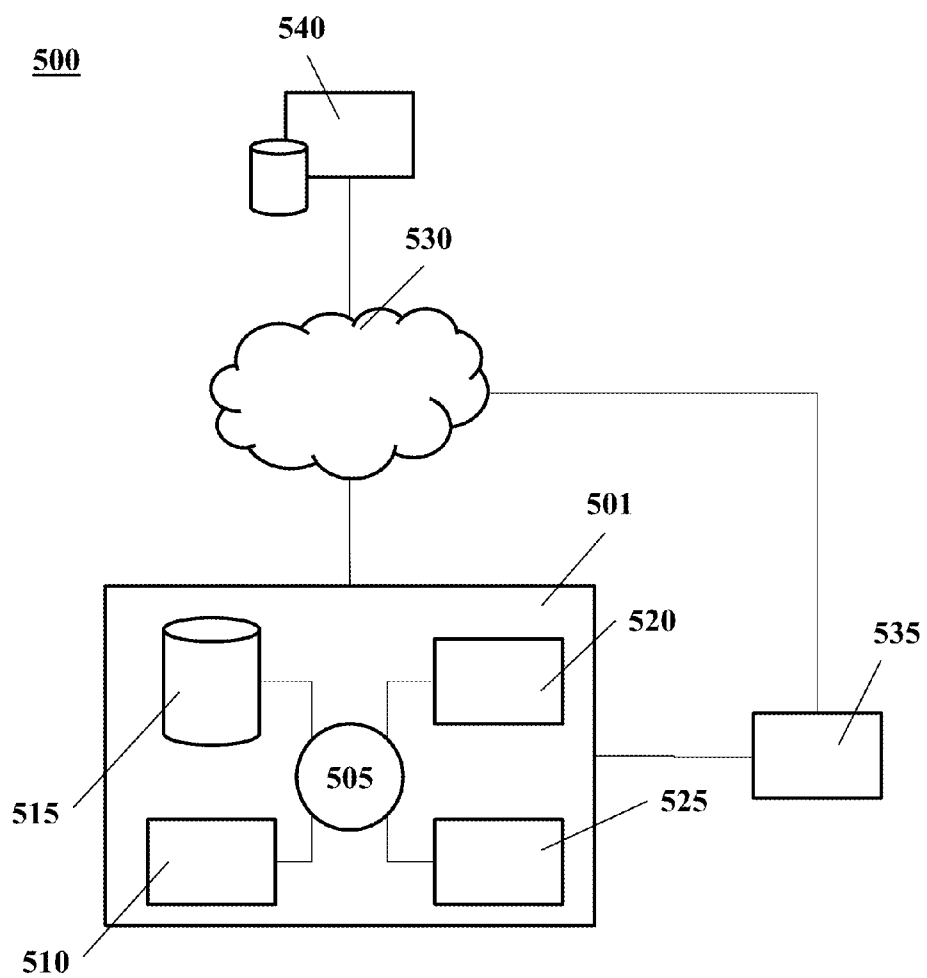

FIG. 5

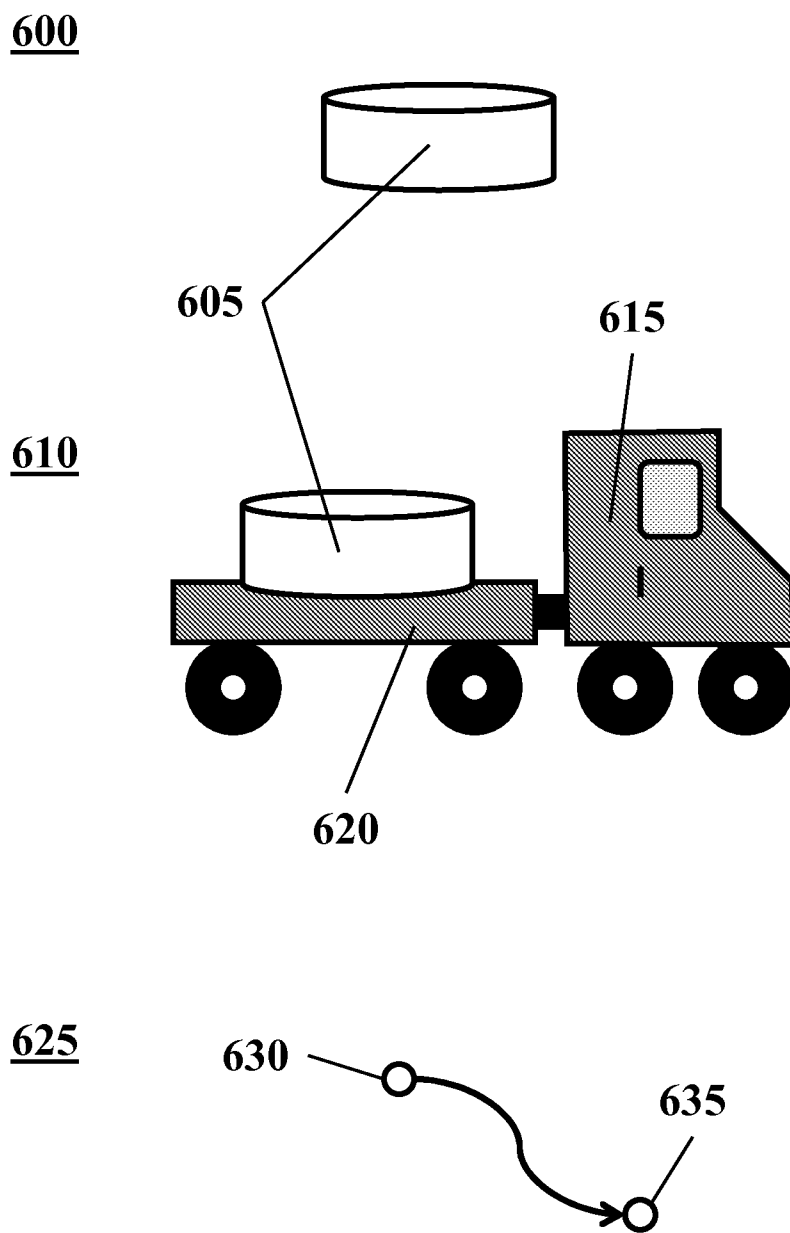

FIG. 6

700

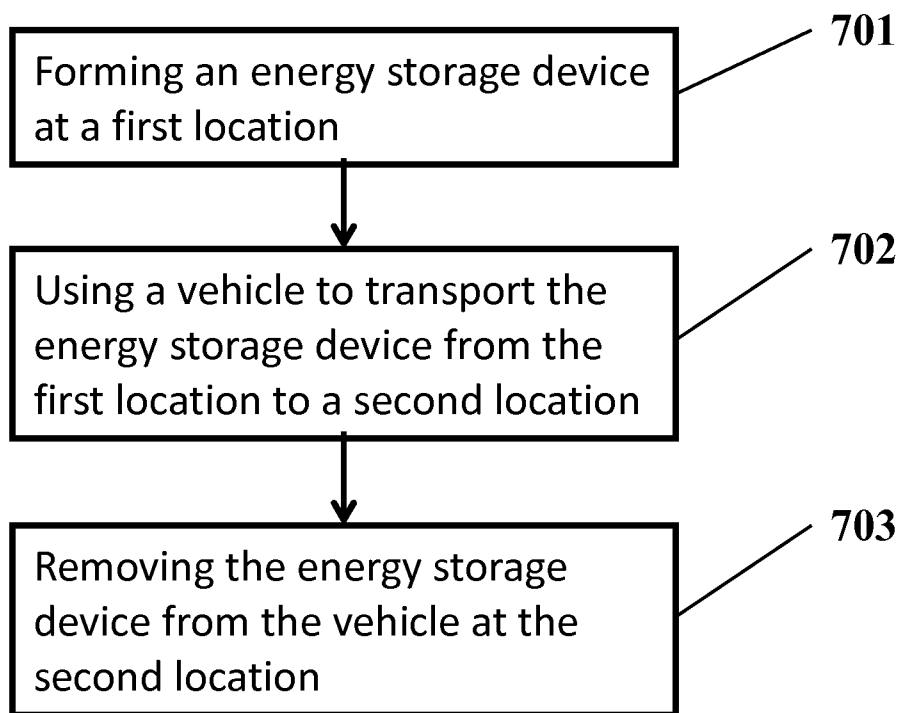

FIG. 7

ELECTROCHEMICAL ENERGY STORAGE DEVICES

CROSS-REFERENCE

[0001] This application is a continuation application of PCT Application No. PCT/US2013/065092, filed Oct. 15, 2013, which claims the benefit of U.S. Provisional Application No. 61/715,821, filed Oct. 18, 2012, and U.S. patent application Ser. No. 13/801,333, filed on Mar. 13, 2013, each of which is entirely incorporated herein by reference.

BACKGROUND

[0002] A battery can be a device capable of converting stored chemical energy into electrical energy. Batteries can be used in many household and industrial applications. In some instances, batteries are rechargeable such that electrical energy is capable of being stored in the battery as chemical energy (i.e., charging the battery). The battery can be coupled to a load (e.g., electrical appliance) and employed for use in performing work.

SUMMARY

[0003] The present disclosure recognizes a need for energy storage devices (e.g., batteries) that are capable of storing a large amount of energy and are transportable on a vehicle (e.g., truck). Several aspects of the energy storage devices are described.

[0004] An aspect of the present disclosure provides an energy storage device comprising at least one liquid metal electrode, wherein the energy storage device has an energy storage capacity of at least about 1 kWh and a response time less than or equal to about 100 milliseconds (ms).

[0005] Another aspect of the present disclosure provides an energy storage device comprising at least one liquid metal electrode stored in a container at a temperature greater than or equal to about 250° C., wherein the energy storage device has an energy storage capacity of at least about 1 kWh, and wherein the container has a surface area-to-volume ratio that is less than or equal to about 100 m⁻¹.

[0006] Another aspect of the present disclosure provides an energy storage device comprising at least one liquid metal electrode, wherein the energy storage device maintains at least 90% of its energy storage capacity after 100 charge/discharge cycles, and wherein the energy storage device has an energy storage capacity of at least about 1 kWh.

[0007] Another aspect of the present disclosure provides an energy storage device comprising at least one liquid metal electrode, wherein the device is transportable on a vehicle and has an energy storage capacity of at least about 1 kWh, and wherein the energy storage device is transportable with at least any two of an anode, cathode and electrolyte of the energy storage device in solid state.

[0008] Another aspect of the present disclosure provides an energy storage device comprising a container containing one or more cells, an individual cell of the one or more cells containing at least one liquid metal electrode, wherein a rate of heat generation in the cell during charge/discharge is about equal to a rate of heat loss from the cell.

[0009] Another aspect of the present disclosure provides a separator-less energy storage device comprising a container with at least one liquid metal electrode, wherein the container has a surface area-to-volume ratio that is less than or equal to about 100 m⁻¹, and the separator-less energy storage device

has (i) a response time less than or equal to about 100 milliseconds (ms), and/or (ii) an energy storage capacity of at least about 1 kWh.

[0010] Another aspect of the present disclosure provides a method for forming an energy storage device, comprising shipping a container comprising an energy storage material in solid state to a destination location, and at the destination location supplying energy to the energy storage material to form at least one of a liquid metal anode, liquid metal cathode, and liquid electrolyte, thereby forming the energy storage device.

[0011] Another aspect of the present disclosure provides an energy storage system, comprising: (a) a container comprising one or more energy storage cells, wherein an individual energy storage cell of the one or more energy storage cells comprises an energy storage material comprising at least one liquid metal electrode; and (b) a control system comprising a processor with machine-executable code for monitoring at least one temperature of the one or more energy storage cells and/or the container, wherein the processor regulates the flow of electrical energy into at least a subset of the one or more energy storage cells such that the energy storage material undergoes sustained self heating during charge/discharge.

[0012] Another aspect of the present disclosure provides an energy storage device comprising at least one electrochemical cell having an operating temperature, the at least one electrochemical cell comprising: (a) a liquid negative electrode comprising a first metal; (b) a liquid electrolyte adjacent to the liquid negative electrode; and (c) a liquid positive electrode adjacent to the liquid electrolyte, the liquid positive electrode comprising a second elemental metal that is different than the first metal, wherein the liquid electrolyte comprises a charged species of the first metal and an oppositely charged species of the second metal, and wherein the energy storage device is capable of being transported on a vehicle.

[0013] Another aspect of the present disclosure provides an energy storage device comprising a molten salt, wherein a liquid electronic conductor is extracted from the molten salt by oxidation and metal is extracted from the molten salt by reduction, and wherein the energy storage device is capable of being transported on a vehicle.

[0014] Another aspect of the present disclosure provides an electrometallurgical cell comprising a positive electrode and a negative electrode, wherein the electrodes are liquid, the reactants of reactions that occur at the electrodes are liquid, and the products of reactions that occur at the electrodes are liquid, and wherein the electrometallurgical cell is capable of being transported on a vehicle.

[0015] Another aspect of the present disclosure provides an energy storage device capable of being transported on a vehicle and having a power capacity of greater than 1 MW and: (a) a physical footprint smaller than about 100 m²/MW; (b) a cycle life greater than 3000 deep discharge cycles; (c) a lifespan of at least 10 years; (d) a DC-to-DC efficiency of at least 65%; (e) a discharge capacity of at most 10 hours; and (f) a response time of less than 100 milliseconds.

[0016] Another aspect of the present disclosure provides an energy storage device comprising a liquid electrode, the electrode comprising an additive, wherein the electrode is consumed and the additive is concentrated by operation of the device, and wherein a property of the device is determined by of the concentration of the additive, and wherein the energy storage device is capable of being transported on a vehicle.

[0017] Another aspect of the present disclosure provides an energy storage device comprising a liquid antimony electrode, a steel container and a layer of iron antimonide disposed therebetween, wherein the device is operated at less than 738° C., and wherein the energy storage device is capable of being transported on a vehicle.

[0018] Another aspect of the present disclosure provides an energy storage device comprising a liquid electrode and a current collector in contact with the electrode, wherein the liquid electrode is consumed in a reaction during operation of the device, and wherein the amount of liquid electrode is in stoichiometric excess relative to other reactants of the reaction such that the current collector is in contact with the liquid electrode when the reaction has proceeded to completion, and wherein the energy storage device is capable of being transported on a vehicle.

[0019] Another aspect of the present disclosure provides an energy storage device comprising an alkaline earth metal present in each of a positive electrode, a negative electrode and a liquid electrolyte, wherein the energy storage device is capable of being transported on a vehicle.

[0020] Another aspect of the present disclosure provides an energy storage device comprising an alkaline earth metal present in each of an elemental form, an alloy form and a halide form, wherein the energy storage device is capable of being transported on a vehicle.

[0021] Another aspect of the present disclosure provides an energy storage device comprising a liquid anode, a liquid cathode and a liquid electrolyte disposed therebetween, wherein the thickness of the electrolyte is substantially constant through a charge-discharge cycle of the device, and wherein the energy storage device is capable of being transported on a vehicle.

[0022] Another aspect of the present disclosure provides an energy storage device comprising a liquid anode, a liquid cathode and a liquid electrolyte disposed therebetween, wherein the thickness of the electrolyte is less than 50% of the thickness of the cathode or the anode, and wherein the energy storage device is capable of being transported on a vehicle.

[0023] Another aspect of the present disclosure provides an energy storage device comprising a liquid electrode comprising an elemental alkaline earth metal and an electrolyte comprising a halide of the alkaline earth metal, wherein the electrolyte further comprises complexing ligands, and wherein the energy storage device is capable of being transported on a vehicle.

[0024] Another aspect of the present disclosure provides an energy storage device comprising a conductive housing comprising a conductive liquid anode, a conductive liquid cathode and an electrolyte disposed therebetween, wherein the interior surface of the container is not electrically insulated, and wherein the energy storage device is capable of being transported on a vehicle.

[0025] Another aspect of the present disclosure provides an energy storage device comprising an anode comprising a first electronically conductive liquid and a cathode comprising a second electronically conductive liquid, wherein the device is configured to impede mixing of the electronically conductive liquids, and wherein the energy storage device is capable of being transported on a vehicle.

[0026] Another aspect of the present disclosure provides an energy storage device comprising a negative electrode comprising an alkali metal, a positive electrode comprising the alkali metal and one or more additional elements and a liquid

electrolyte disposed between the electrodes, wherein the electrolyte is not depleted upon charging or discharging of the device, and wherein the energy storage device is capable of being transported on a vehicle.

[0027] Another aspect of the present disclosure provides an energy storage device comprising a liquid metal electrode, a second metal electrode that is a liquid and an electrolyte disposed between the electrodes, wherein the electrolyte is a paste, and wherein the energy storage device is capable of being transported on a vehicle.

[0028] Another aspect of the present disclosure provides an energy storage device comprising a liquid negative electrode comprising an alkali metal, a liquid positive electrode comprising an alloy of the alkali metal and an electrolyte disposed between the electrodes, wherein the electrolyte comprises a salt of the alkali metal and particles, and wherein the energy storage device is capable of being transported on a vehicle.

[0029] Another aspect of the present disclosure provides an energy storage device comprising a metal anode, a metal cathode and an electrolyte disposed between the electrodes, wherein the anode, cathode and electrolyte are liquids at an operating temperature of the device and the operating temperature of the device is less than 500° C., and wherein the energy storage device is capable of being transported on a vehicle.

[0030] Another aspect of the present disclosure provides a method for charging an energy storage device comprising connecting an external charging circuit to terminals of the energy storage device that is capable of being transported on a vehicle such that an active alkali metal moves from a positive electrode, through an electrolyte, to a negative electrode comprising a metal having a higher chemical potential than the positive electrode.

[0031] Another aspect of the present disclosure provides a method for discharging an energy storage device comprising connecting an external load to terminals of the energy storage device that is capable of being transported on a vehicle such that an active alkali metal moves from a negative electrode, through an electrolyte as cations, to a positive electrode where the active alkali metal forms a neutral metal having a lower chemical potential than the negative electrode.

[0032] Another aspect of the present disclosure provides an energy storage device comprising a liquid metal electrode, an electrolyte and a current collector in contact with the electrode, wherein the current collector comprises a material that has a greater wettability with the liquid metal than with the electrolyte.

[0033] Another aspect of the present disclosure provides an electrochemical energy storage device comprising an anode, a cathode and an electrolyte between said anode and said cathode, wherein the device is not capable of conducting ions through said electrolyte at a first temperature, and wherein the device is capable of conducting ions through said electrolyte at a second temperature that is greater than said first temperature, and wherein said device is configured to be transported at the first temperature at a potential difference between said anode and said cathode that is less than 1 volt.

[0034] Another aspect of the present disclosure provides an electrochemical energy storage device comprising a negative electrode and a positive electrode and an electrolyte disposed between said negative and positive electrodes, wherein the electrochemical energy storage device has a first potential difference between the negative and positive electrodes at a first temperature that is less than about 50° C. and a second

potential difference between the negative and positive electrodes at a second temperature of at least about 250° C., wherein the second potential difference is greater than the first potential difference.

[0035] Another aspect of the present disclosure provides a method for forming an energy storage system, comprising: (a) forming, at a first location, an energy storage device comprising a negative electrode and a positive electrode, and an electrolyte between the negative electrode and the positive electrode, wherein the negative electrode, positive electrode and electrolyte are in the liquid at an operating temperature of the energy storage device; and (b) placing the energy storage device on a vehicle that is configured to transport the energy storage device from the first location to a second location.

[0036] Additional aspects and advantages of the present disclosure will become readily apparent to those skilled in this art from the following detailed description, wherein only illustrative embodiments of the present disclosure are shown and described. As will be realized, the present disclosure is capable of other and different embodiments, and its several details are capable of modifications in various obvious respects, all without departing from the disclosure. Accordingly, the drawings and description are to be regarded as illustrative in nature, and not as restrictive.

INCORPORATION BY REFERENCE

[0037] All publications, patents, and patent applications mentioned in this specification are herein incorporated by reference to the same extent as if each individual publication, patent, or patent application was specifically and individually indicated to be incorporated by reference.

BRIEF DESCRIPTION OF THE DRAWINGS

[0038] The novel features of the invention are set forth with particularity in the appended claims. A better understanding of the features and advantages of the present invention will be obtained by reference to the following detailed description that sets forth illustrative embodiments, in which the principles of the invention are utilized, and the accompanying drawings or figures (also “FIG.” and “FIGS.” herein), of which:

[0039] FIG. 1 is an illustration of an electrochemical cell (A) and a compilation (i.e., battery) of electrochemical cells (B and C);

[0040] FIG. 2 is a schematic cross sectional illustration of a battery housing having a conductor in electrical communication with a current collector pass through an aperture in the housing;

[0041] FIG. 3 is a cross-sectional side view of an electrochemical cell or battery;

[0042] FIG. 4 is a cross-sectional side view of an electrochemical cell or battery with an intermetallic layer;

[0043] FIG. 5 is an illustration of a computer system;

[0044] FIG. 6 is an illustration of an electrochemical energy storage device being transported on a truck; and

[0045] FIG. 7 illustrates a method for forming an energy storage system.

DETAILED DESCRIPTION

[0046] While various embodiments of the invention have been shown and described herein, it will be obvious to those skilled in the art that such embodiments are provided by way of example only. Numerous variations, changes, and substi-

tutions may occur to those skilled in the art without departing from the invention. It should be understood that various alternatives to the embodiments of the invention described herein may be employed.

[0047] The term “surface area,” as used herein, generally refers to the geometric surface area of an object.

[0048] The term “vehicle,” as used herein, generally refers to a car, truck, train, motorcycle, helicopter, plane, ship, boat, or robot. A vehicle can be manned or unmanned. A vehicle can be configured to travel alone a road or other pathway, such as a waterway. A vehicle can be coupled to a trailer or other container that is configured to house an energy storage device or a container having the energy storage device.

[0049] The term “cell,” as used herein, generally refers to an electrochemical cell. A cell can include a negative electrode of material ‘A’ and a positive electrode of material ‘B’, denoted as A|B. The positive and negative electrodes can be separated by an electrolyte.

[0050] The term “module,” as used herein, generally refers to cells that are attached together in parallel by, for example, mechanically connecting the cell housing of one cell with the cell housing of an adjacent cell (e.g., cells that are connected together in an approximately horizontal packing plane). A module can include a plurality of cells in parallel. A module can comprise any number of cells (e.g., 2, 3, 4, 5, 6, 7, 8, 9, 10, 11, 12, 13, 14, 15, 16, 17, 18, 19, 20, or more). In some cases, a module comprises 9, 12, or 16 cells. In some cases, a module is capable of storing about 700 Watt-hours of energy and/or delivering about 175 Watts of power.

[0051] The term “pack,” as used herein, generally refers to modules that are attached through different electrical connections (e.g., vertically). A pack can comprise any number of modules (e.g., 1, 2, 3, 4, 5, 6, 7, 8, 9, 10, 11, 12, 13, 14, 15, 16, 17, 18, 19, 20, or more). In some cases, a pack comprises 3 modules. In some cases, a pack is capable of storing about 2 kilo-Watt-hours of energy and/or delivering about 0.5 kilo-Watts of power.

[0052] The term “core,” as used herein generally refers to a plurality of modules or packs that are attached through different electrical connections (e.g., in series and/or parallel). A core can comprise any number of modules or packs (e.g., 1, 2, 3, 4, 5, 6, 7, 8, 9, 10, 11, 12, 13, 14, 15, 16, 17, 18, 19, 20, or more). In some cases, the core also comprises mechanical, electrical, and thermal systems that allow the core to efficiently store and return electrical energy in a controlled manner. In some cases, a core comprises 12 packs. In some cases, a core is capable of storing about 25 kilo-Watt-hours of energy and/or delivering about 6.25 kilo-Watts of power.

[0053] The term “pod,” as used herein, generally refers to a plurality of cores that are attached through different electrical connections (e.g., in series and/or parallel). A pod can comprise any number of cores (e.g., 1, 2, 3, 4, 5, 6, 7, 8, 9, 10, 11, 12, 13, 14, 15, 16, 17, 18, 19, 20, or more). In some cases, the pod contains cores that are connected in parallel with appropriate by-pass electronic circuitry, thus enabling a core to be disconnected while continuing to allow the other cores to store and return energy. In some cases, a pod comprises 4 cores. In some cases, a pod is capable of storing about 100 kilo-Watt-hours of energy and/or delivering about 25 kilo-Watts of power.

[0054] The term “system,” as used herein, generally refers to a plurality of cores or pods that are attached through different electrical connections (e.g., in series and/or parallel). A system can comprise any number of cores or pods (e.g., 2, 3,

4, 5, 6, 7, 8, 9, 10, 11, 12, 13, 14, 15, 16, 17, 18, 19, 20, or more). In some cases, a system comprises 20 pods. In some cases, a system is capable of storing about 2 megawatt-hours of energy and/or delivering about 500 kilowatts of power.

[0055] The term “battery,” as used herein, generally refers to one or more electrochemical cells connected in series and/or parallel. A battery can comprise any number of electrochemical cells, modules, packs, cores, pods or systems.

Electrochemical Energy Storage Cells, Devices and Systems

[0056] The disclosure provides electrochemical energy storage devices (batteries) and systems. An electrochemical energy storage device generally includes at least one electrochemical cell, also “cell” and “battery cell” herein, sealed (e.g., hermetically sealed) within a housing.

[0057] An electrochemical cell of the disclosure may include a negative electrode, an electrolyte adjacent to the negative electrode, and a positive electrode adjacent to the electrolyte. The negative electrode can be separated from the positive electrode by the electrolyte. The negative electrode can be an anode during discharging. The positive electrode can be a cathode during discharging. In some examples, an electrochemical cell is a liquid metal battery cell. In some examples, a liquid metal battery cell can include a liquid electrolyte arranged between a negative liquid (e.g., molten) metal electrode and a positive liquid (e.g., molten) metal, metalloid and/or non-metal electrode. In some cases, a liquid metal battery cell has a molten alkali metal (e.g., lithium, magnesium, sodium) negative electrode, an electrolyte, and a molten metal positive electrode. The molten metal positive electrode can include one or more of tin, lead, bismuth, antimony, tellurium and selenium. Any description of a metal or molten metal positive electrode, or a positive electrode, herein may refer to an electrode including one or more of a metal, a metalloid and a non-metal. The positive electrode may contain one or more of the listed examples of materials. In an example, the molten metal positive electrode can include lead and antimony. In some examples, the molten metal positive electrode may include an alkali metal alloyed in the positive electrode.

[0058] In some examples, an electrochemical energy storage device includes a liquid metal negative electrode, a liquid metal positive electrode, and a liquid metal electrolyte separating the liquid metal negative electrode and the liquid metal positive electrode. The negative electrode can include an alkali metal, such as lithium, sodium, potassium, rubidium, cesium, or combinations thereof. The positive electrode can include elements selected from Group IIIA, IVA, VA and VIA of the periodic table of the elements, such as aluminum, gallium, indium, silicon, germanium, tin, lead, pnictogens (e.g., arsenic, bismuth and antimony), chalcogens (e.g., tellurium and selenium), or combinations thereof. The electrolyte can include a salt (e.g., molten salt), such as an alkali metal salt. The alkali metal salt can be a halide, such as a fluoride, chloride, bromide, or iodide of the active alkali metal, or combinations thereof. In an example, the electrolyte includes lithium chloride. As an alternative, the salt of the active alkali metal can be, for example, a non-chloride halide, bistriflimide, fluorosulfano-amine, perchlorate, hexafluorophosphate, tetrafluoroborate, carbonate, hydroxide, or combinations thereof.

[0059] In some cases, the negative electrode and the positive electrode of an electrochemical energy storage device are in the liquid state at an operating temperature of the energy

storage device. To maintain the electrodes in the liquid states, the battery cell may be heated to any suitable temperature. In some examples, the battery cell is heated to and/or maintained at a temperature of about 200° C., about 250° C., about 300° C., about 350° C., about 400° C., about 450° C., about 500° C., about 550° C., about 600° C., about 650° C., or about 700° C. The battery cell may be heated to and/or maintained at a temperature of at least about 200° C., at least about 250° C., at least about 300° C., at least about 350° C., at least about 400° C., at least about 450° C., at least about 500° C., at least about 550° C., at least about 600° C., at least about 650° C., or at least about 700° C. In some situations, the battery cell is heated to between 200° C. and about 500° C., or between about 300° C. and 450° C.

[0060] Electrochemical cells of the disclosure may be adapted to cycle between charged (or energy storage) modes and discharged modes. In some examples, an electrochemical cell can be fully charged, partially charged or partially discharged, or fully discharged.

[0061] In some implementations, during a charging mode of an electrochemical energy storage device, electrical current received from an external power source (e.g., a generator or an electrical grid) may cause metal atoms in the metal positive electrode to release one or more electrons, dissolving into the electrolyte as a positively charged ion (i.e., cation). Simultaneously, cations of the same species can migrate through the electrolyte, and may accept electrons at the negative electrode, causing the cations to transition to a neutral metal species, thereby adding to the mass of the negative electrode. The removal of the active metal species from the positive electrode and the addition of the active metal to the negative electrode stores electrochemical energy. During an energy discharge mode, an electrical load is coupled to the electrodes and the previously added metal species in the negative electrode can be released from the metal negative electrode, pass through the electrolyte as ions, and alloy with the positive electrode, with the flow of ions accompanied by the external and matching flow of electrons through the external circuit/load. This electrochemically facilitated metal alloying reaction discharges the previously stored electrochemical energy to the electrical load.

[0062] In a charged state, the negative electrode can include negative electrode material and the positive electrode can include positive electrode material. During discharging (e.g., when the battery is coupled to a load), the negative electrode material yields one or more electrons and cations of the negative electrode material. The cations migrate through the electrolyte to the positive electrode material and react with the positive electrode material to form an alloy. During charging, the alloy at the positive electrode disassociates to yield cations of the negative electrode material, which migrates through the electrolyte to the negative electrode.

[0063] In some examples, ions can migrate through an electrolyte from an anode to a cathode, or vice versa. In some cases, ions can migrate through an electrolyte in a push-pop fashion in which an entering ion of one type ejects an ion of the same type from the electrolyte. For example, during discharge, a lithium anode and a lithium chloride electrolyte can contribute a lithium cation to a cathode by a process in which a lithium cation formed at the anode interacts with the electrolyte to eject a lithium cation from the electrolyte into the cathode. The lithium cation formed at the anode in such a case may not necessarily migrate through the electrolyte to the

cathode. The cation can be formed at an interface between the anode and the electrolyte, and accepted at an interface of the cathode and the electrolyte.

[0064] Electrochemical cells of the disclosure can include housings that may be suited for various uses and operations. A housing can include one cell or a plurality of cells. A housing can be configured to electrically couple the electrodes to a switch, which can be connected to the external power source and the electrical load. The cell housing may include, for example, an electrically conductive container that is electrically coupled to a first pole of the switch and/or another cell housing, and an electrically conductive container lid, a portion of which is electrically coupled to a second pole of the switch and/or another cell housing. The cell can be arranged within a cavity of the container. A first one of the electrodes of the cell can contact and be electrically coupled with an endwall of the container. An electrically insulating sheath (e.g., alumina sheath) may electrically insulate remaining portions of the cell from other portions of the container. A conductor can electrically couple a second one of the electrodes of the battery cell to the container lid, which can seal (e.g., hermetically seal) the battery cell within the cavity. The container and the container lid can be electrically isolated. As an alternative, a housing does not include an electrically insulating sheath. In some cases, a housing and/or container may be a battery housing and/or container. An electrically conductive sheath (e.g. graphite sheath) may prevent the cathode from wetting up the side walls of the container.

[0065] A battery, as used herein, can comprise a plurality of electrochemical cells. Individual cells of the plurality can be electrically coupled to one another in series and/or in parallel and/or a combination of series and parallel connections. In serial connectivity, the positive terminal of a first cell is connected to a negative terminal of a second cell. In parallel connectivity, the positive terminal of a first cell can be connected to a positive terminal of a second cell.

[0066] Reference will now be made to the figures, wherein like numerals refer to like parts throughout. It will be appreciated that the figures and features therein are not necessarily drawn to scale.

[0067] With reference to FIG. 1, an electrochemical cell (A) is a unit comprising an anode and a cathode. The cell may comprise an electrolyte and be sealed in a housing as described herein. In some cases, the electrochemical cells can be stacked (B) to form a battery (i.e., a compilation of electrochemical cells). The cells can be arranged in parallel, in series, or both in parallel and in series (C).

[0068] Electrochemical cells of the disclosure may be capable of storing and/or receiving input of ("taking in") substantially large amounts of energy. In some instances, a cell is capable of storing and/or taking in about 1 watt hour (Wh), about 5 Wh, 25 Wh, about 50 Wh, about 100 Wh, about 500 Wh, about 1 kilo-Wh (kWh), about 1.5 kWh, about 2 kWh, about 3 kWh, about 5 kWh, about 10 kWh, about 100 kWh, about 500 kWh, about 1 MWh, about 5 MWh, about 10 MWh, about 50 MWh, or about 100 MWh. In some instances, the battery is capable of storing and/or taking in at least about 1 Wh, at least about 5 Wh, at least about 25 Wh, at least about 50 Wh, at least about 100 Wh, at least about 500 Wh, at least about 1 kWh, at least about 1.5 kWh, at least about 2 kWh, at least about 3 kWh, at least about 5 kWh, at least about 10 kWh, at least about 100 kWh, at least about 500 kWh, at least

about 1 MWh, at least about 5 MWh, at least about 10 MWh, at least about 50 MWh, or at least about 100 MWh.

[0069] A compilation or array of cells (i.e., battery) can include any suitable number of cells, such as at least about 2, at least about 5, at least about 10, at least about 50, at least about 100, at least about 500, at least about 1000, at least about 5000, at least about 10000, and the like. In some examples, a battery includes 1, 2, 3, 4, 5, 6, 7, 8, 9, 10, 15, 20, 30, 40, 50, 60, 70, 80, 90, 100, 200, 300, 400, 500, 600, 700, 800, 900, 1000, 2000, 5000, 10,000, 20,000, 50,000, 100,000, 500,000, or 1,000,000 cells.

[0070] Batteries of the disclosure may be capable of storing and/or taking in a substantially large amount of energy for use with a power grid (i.e., a grid-scale battery) or other loads or uses. In some instances, a battery is capable of storing and/or taking in about 5 kWh, 25 kWh, about 50 kWh, about 100 kWh, about 500 kWh, about 1 megawatt hour (MWh), about 1.5 MWh, about 2 MWh, about 3 MWh, about 5 MWh, or about 10 MWh. In some instances, the battery is capable of storing and/or taking in at least about 1 kWh, at least about 5 kWh, at least about 25 kWh, at least about 50 kWh, at least about 100 kWh, at least about 500 kWh, at least about 1 MWh, at least about 1.5 MWh, at least about 2 MWh, at least about 3 MWh, or at least about 5 MWh, or at least about 10 MWh.

[0071] In some instances, the cells and cell housings are stackable. Any suitable number of cells can be stacked. Cells can be stacked side-by-side, on top of each other, or both. In some instances, at least about 10, 50, 100, or 500 cells are stacked. In some cases, a stack of about 1000 cells is capable of storing and/or taking in at least 50 kWh of energy. A first stack of cells (e.g., 10 cells) can be electrically connected to a second stack of cells (e.g., another 10 cells) to increase the number of cells in electrical communication (e.g., 20 in this instance).

[0072] An electrochemical energy storage device can include one or more individual electrochemical cells. An electrochemical cell can be housed in a container, which can include a container lid. The device can include at least 1, 2, 3, 4, 5, 6, 7, 8, 9, 10, 20, 30, 40, 50, 100, 200, 300, 400, 500, 1000, 10,000, 20,000, or 50,000 cells. The container lid may utilize, for example, a gasket (e.g., annular dielectric gasket) to electrically isolate the container from the container lid. Such a gasket may be constructed from a relatively hard electrically insulating material, such as, for example, glass, silicon oxide, aluminum oxide, boron nitride, aluminum nitride, or other oxides comprising of lithium oxide, calcium oxide, barium oxide, yttrium oxide, silicon oxide, aluminum oxide, or lithium nitride. The gasket may be subject to relatively high compressive forces (e.g., greater than 10,000 psi) between the container lid and the container in order to provide a seal in addition to electrical isolation. In order to subject the dielectric gasket to such high compressive forces, the fasteners may have relatively large diameters and may be closely spaced together. Such large diameter fasteners may be expensive and, thus, may significantly increase the cost to build a relatively large diameter container. In addition, as the diameter of the dielectric gasket is increased to accommodate a large diameter container, the gasket may become more and more fragile and difficult to maneuver.

[0073] FIG. 2 schematically illustrates a battery that comprises an electrically conductive housing 201 and a conductor 202 in electrical communication with a current collector 203. The conductor can be electrically isolated from the housing

and can protrude through the housing through an aperture in the housing such that the conductor of a first cell contacts the housing of a second cell when the first and second cells are stacked.

[0074] A cell housing can comprise an electrically conductive container and a conductor in electrical communication with a current collector. The conductor may protrude through the housing through an aperture in the container and may be electrically isolated from the container. The conductor of a first housing may contact the container of a second housing when the first and second housings are stacked.

[0075] In some instances, the area of the aperture through which the conductor protrudes from the housing and/or container is small relative to the area of the housing and/or container. In some cases, the ratio of the area of the aperture to the area of the housing is about 0.001, about 0.005, about 0.01, about 0.05, about 0.1, about 0.15, or about 0.2. In some cases, the ratio of the area of the aperture to the area of the housing is less than or equal to 0.001, less than or equal to 0.005, less than or equal to 0.01, less than or equal to 0.05, less than or equal to 0.1, less than or equal to 0.15, or less than or equal to 0.2.

[0076] A cell can comprise an electrically conductive housing and a conductor in electrical communication with a current collector. The conductor protrudes through the housing through an aperture in the housing and may be electrically isolated from the housing. The ratio of the area of the aperture to the area of the housing may be less than about 0.1.

[0077] A cell housing can comprise an electrically conductive container and a conductor in electrical communication with a current collector. The conductor protrudes through the container through an aperture in the container and is electrically isolated from the container. The ratio of the area of the aperture to the area of the container may be less than 0.1. The housing can be capable of enclosing a cell that is capable of storing and/or taking in less than 100 Wh of energy, about 100 Wh of energy, or more than 100 Wh of energy.

[0078] FIG. 3 is a cross-sectional side view of an electrochemical cell or battery 300 comprising a housing 301, a conductive feed-through (i.e., conductor, such as a conductor rod) 302 that passes through an aperture in the housing and is in electronic communication with a liquid metal negative electrode 303, a liquid metal positive electrode 305, and a liquid metal electrolyte between the electrodes 303, 305. The conductor 302 may be electrically isolated from the housing 301 (e.g., using electrically insulating gaskets). The negative electrode 303 may be a foam that behaves like a sponge, and is "soaked" in liquid metal. The negative liquid metal electrode 303 is in contact with the molten salt electrolyte 304, which is in contact with the positive liquid metal electrode 305. The positive liquid metal electrode 305 can contact the housing 301 along the side walls and/or along the bottom end wall of the housing.

[0079] The foam can be porous. The foam can include pores that are sized to permit ions to flow through the pores. The foam can be sized to permit the liquid metal to flow through the foam.

[0080] The housing 301 can be constructed from an electrically conductive material such as, for example, steel, iron, stainless steel, graphite, nickel, nickel based alloys, titanium, aluminum, molybdenum, or tungsten. The housing may also comprise a thinner lining component of a separate metal or

electrically insulating coating, such as, for example, a steel housing with a graphite lining, or a steel housing with a boron or boron nitride coating.

[0081] The housing 301 may include a thermally and/or electrically insulating sheath 306. In this configuration, the negative electrode 303 may extend laterally between the side walls of the housing 301 defined by the sheath without being electrically connected (i.e., shorted) to the positive electrode 305. Alternatively, the negative electrode 303 may extend laterally between a first negative electrode end 303a and a second negative electrode end 303b. When the sheath 306 is not provided, the negative electrode 303 may have a diameter (or other characteristic dimension, illustrated in FIG. 3 as the distance from 303a to 303b) that is less than the diameter (or other characteristic dimension such as width for a cuboid container, illustrated in FIG. 3 as the distance D) of the cavity defined by the housing 301.

[0082] The sheath 306 can be constructed from a thermally insulating and/or electrically insulating material such as, for example, alumina, titania, silica, magnesia, boron nitride, or a mixed oxide including calcium oxide, aluminum oxide, silicon oxide, lithium oxide, magnesium oxide, etc. As shown in FIG. 3, the sheath 306 has an annular, square, or rectangular cross-sectional geometry that can extend laterally between a first sheath end 306a and a second sheath end 306b. The sheath may be dimensioned (illustrated in FIG. 3 as the distance from 306a to 306b) such that the sheath is in contact and pressed up against the side walls of the cavity defined by the housing cavity 301. As an alternative, the sheath can be used to prevent corrosion of the container and/or prevent wetting of the cathode material up the side wall, and may be constructed out of an electronically conductive material, such as steel, stainless steel, tungsten, molybdenum, nickel, nickel based alloys, graphite, or titanium. The sheath may be very thin and could be a coating. The coating can cover just the inside of the walls, and/or, can also cover the bottom of the inside of the container.

[0083] The housing 301 can also include a first (e.g., negative) current collector 307 and a second (e.g., positive) current collector 308. The negative current collector 307 may be constructed from an electrically conductive material such as, for example, nickel-iron (Ni-Fe) foam, perforated steel disk, sheets of corrugated steel, sheets of expanded metal mesh, etc. The negative current collector 307 may be configured as a plate that can extend laterally between a first collector end 307a and a second collector end 307b. The negative current collector 307 may have a collector diameter that is less than or equal to the diameter of the cavity defined by the housing 301. In some cases, the negative current collector 307 may have a collector diameter (or other characteristic dimension, illustrated in FIG. 3 as the distance from 307a to 307b) that is less than, equal to, or more than the diameter (or other characteristic dimension, illustrated in FIG. 3 as the distance from 303a to 303b) of the negative electrode 303. The positive current collector 308 may be configured as part of the housing 301; for example, the bottom end wall of the housing may be configured as the positive current collector 308, as illustrated in FIG. 3. Alternatively, the current collector may be discrete from the battery housing and may be electrically connected to the battery housing. In some cases, the positive current collector may not be electrically connected to the battery housing. The present invention is not limited to any particular configurations of the negative and/or positive current collector configurations.

[0084] The negative electrode **303** can be contained within the negative current collector (e.g., foam) **307**. In this configuration, the electrolyte layer comes up in contact with the bottom and sides of the foam **307**, and the metal contained in the foam (i.e., the negative electrode material) can be held away from the sidewalls of the housing **301**, thus allowing the cell to run without the insulating sheath **306**. In some cases, a graphite sheath may be used to prevent the positive electrode from wetting up along the side walls, which can prevent shorting of the cell.

[0085] Current may be distributed substantially evenly across a positive and/or negative liquid metal electrode in contact with an electrolyte along a surface (i.e., the current flowing across the surface may be uniform such that the current flowing through any portion of the surface does not substantially deviate from an average current density). In some examples, the maximum density of current flowing across an area of the surface is less than about 105%, less than about 115%, less than about 125%, less than about 150%, less than about 175%, less than about 200%, less than about 250%, or less than about 300% of the average density of current flowing across the surface. In some examples, the minimum density of current flowing across an area of the surface is greater than about 50%, greater than about 60%, greater than about 70%, greater than about 80%, greater than about 90%, or greater than about 95% of the average density of current flowing across the surface.

[0086] The housing may include a container and a container lid as described elsewhere herein. The container and container lid may be connected mechanically and isolated electrically (e.g., using electrically insulating gaskets, fasteners with electrically insulating sleeves and/or electrically insulating washers constructed from a dielectric such as, for example, mica or vermiculite). In some examples, the electrochemical cell or battery **300** may comprise two or more conductors passing through one or more apertures and in electrical communication with the liquid metal negative electrode **303**. In some instances, a separator structure (not shown) may be arranged within the electrolyte **304** between the liquid negative electrode **303** and the (liquid) positive electrode **305**.

[0087] Viewed from a top or bottom direction, as indicated respectively by "TOPVIEW" and "BOTTOMVIEW" in FIG. **3**, the cross-sectional geometry of the cell or battery **300** can be circular, elliptical, square, rectangular, polygonal, curved, symmetric, asymmetric or any other compound shape based on design requirements for the battery. In one example, the cell or battery **300** is axially symmetric with a circular cross-section. Components of cell or battery **300** (e.g., component in FIG. **3**) may be arranged within the cell or battery in an axially symmetric fashion. In some cases, one or more components may be arranged asymmetrically, such as, for example, off the center of the axis **309**.

[0088] The combined volume of positive and negative electrode material may be about 20%, about 30%, about 40%, about 50%, about 60%, about 70%, about 80%, about 90%, or about 95% of the volume of the battery (e.g., as defined by the outer-most housing of the battery, such as a shipping container). In some cases, the combined volume of anode and cathode material is at least 20%, at least 30%, at least 40%, at least about 50%, at least about 60%, at least about 70%, at least about 80%, at least about 90%, or at least about 95% of the volume of the battery. The combined volume of the positive and negative electrodes material may expand or contract

during operation due to the expansion or contraction of the positive or negative electrode. In an example, during discharge, the volume of the negative electrode (anode during discharge) may be reduced due to transfer of the negative electrode material to the positive electrode (cathode during discharge), wherein the volume of the positive electrode is increased (e.g., as a result of an alloying reaction). The volume reduction of the negative electrode may or may not equal the volume increase of the positive electrode. The positive and negative electrode materials may react with each other to form a solid or semi-solid mutual reaction compound (also "mutual reaction product" herein), which may have a density that is the same, lower, or higher than the densities of the positive and/or negative electrode materials. Although the mass of material in the electrochemical cell or battery **300** may be constant, one, two or more phases (e.g., liquid or solid) may be present, and each such phase may comprise a certain material composition (e.g., an alkali metal may be present in the materials and phases of the cell at varying concentrations: a liquid metal negative electrode may contain a high concentration of an alkali metal, a liquid metal positive electrode may contain an alloy of the alkali metal and the concentration of the alkali metal may vary during operation, and a mutual reaction product of the positive and negative liquid metal electrodes may contain the alkali metal at a fixed or variable stoichiometry). The phases and/or materials may have different densities. As material is transferred between the phases and/or materials of the electrodes, a change in combined electrode volume may result.

[0089] FIG. **4** is a cross-sectional side view of an electrochemical cell or battery **400** with an intermetallic layer **410**. The intermetallic layer **410** can include a mutual reaction compound that may be formed during discharging at an interface between a positive liquid metal electrode (liquid metal cathode in this configuration) **405** and a liquid metal electrolyte **404**. The mutual reaction compound (or product) can be solid or semi-solid. The intermetallic layer **410** can form at the interface between the liquid metal cathode **405** and the liquid metal electrolyte **404**. In some cases, the intermetallic layer **410** may exhibit liquid properties (e.g., the intermetallic may be semi-solid, or it may be of a higher viscosity or density than one or more adjacent phases/materials).

[0090] In some cases, a negative liquid metal electrode **403** includes lithium, sodium, potassium, magnesium, and/or calcium, the positive liquid metal electrode **405** includes lead, antimony, tin, tellurium and/or bismuth. The intermetallic layer **410** can include any suitable compound such as magnesium antimonide (Mg_3Sb_2), calcium antimonide (Ca_3Sb_2), lithium antimonide (Li_3Sb), lithium bismuthide (Li_3Bi), sodium antimonide (Na_3Sb) or compounds that contain two or more of K, Li, Na, Pb, Bi, Sb, Te, Sn and the like.

[0091] The solid intermetallic layer may develop by growing and expanding horizontally along a direction x . The expansion may be axially symmetrical or asymmetrical with respect to an axis of symmetry **409** located at the center of the cell or battery **400**. Alternatively, the solid intermetallic layer may develop and expand starting from one or more locations (also "nucleation sites" herein) along a surface parallel to the direction x (i.e., the interface between the liquid metal cathode and the liquid metal electrolyte). The nucleation sites may be located in a predetermined pattern along the surface; alternatively, the location of the nucleation sites may be stochastic (random), or determined by natural or induced defects at the interface between the liquid metal cathode and the

liquid metal electrolyte, or elsewhere within the cell or battery **400**. In some examples, the solid intermetallic layer may not grow and expand horizontally. For example, the solid intermetallic layer may form evenly across the interface.

[0092] The solid intermetallic layer may begin developing at or near a vertical location corresponding to the location of the upper surface of the liquid metal cathode at the commencement of discharging (i.e., the interface between the liquid metal cathode and the liquid metal electrolyte at the commencement of discharging), and may then grow in a downward direction *y*. Thus, the solid intermetallic layer may have an upper interface or surface **410a** and a lower interface or surface **410b**. The upper interface **410a** may remain in an approximately fixed location along the axis **409**, while the lower interface **410b** moves in a downward direction during discharge. In some cases, the solid intermetallic layer may grow and/or deform in the downward direction (i.e., intermetallic material is added to the layer from the downward direction opposite to vector *y*). Material buildup along the interface **410b** may cause pressure to build up from below. The pressure may exert a force on the intermetallic layer. The pressure may be hydraulic pressure from the liquid metal cathode **405**. In some cases, the pressure may be due to material stresses in the intermetallic layer **410**. This may, for example, cause the intermetallic layer **410** to bulge or bow upward. In some cases, the liquid metal cathode may break through the intermetallic layer and some liquid metal cathode material may eject into the liquid metal electrolyte past the upper surface of the intermetallic layer, forming fingers or dendritic outgrowths. The intermetallic layer may be partially distorted, and may be ruptured or cracked in one or more locations along the interface **410a**.

[0093] In some cases, a combination of horizontal and downward growth may occur. For example, a layer having a thickness *t* may develop in a downward direction along the central axis, and expand horizontally during discharge at a thickness of less than *t*, about *t*, or larger than *t*. The thickness *t* may also change as a function of discharge or discharge time. The morphology of the interfaces **410a**, **410b** may not be as uniform as shown in FIG. 4. For example, the interfaces may be lumpy, jagged, uneven, spongy or have offshoots, fingers or dendritic characteristics. For example, the interface **410a** can be undulating. Depending on the lateral extent of the intermetallic layer **410** with respect to the dimension of the cavity defined by the side walls of sheath **406** or housing **401** and/or the morphology of the intermetallic layer **410**, one or more interfaces between the liquid metal electrolyte **404** and the liquid metal cathode **405** may exist. The interfaces may provide a means for reduction reactions to proceed at the liquid metal cathode. The solid intermetallic layer may grow by the addition of material formed at or near the interfaces.

[0094] During discharge, the cathode may comprise the liquid metal cathode **405**, and the solid intermetallic layer **410** is formed adjacent to the cathode. As previously described, material can be transferred to the cathode during discharge such that the mass of the cathode grows. The cathode volume may expand as a result of the material addition. The volume expansion may be affected by the alloying reaction. For example, the cathode volume increase after alloying may be about 30% less than expected from adding together the volume of material added to the cathode and the material originally present in the cathode. In some cases, the densities of the intermetallic layer **410** and the liquid metal cathode **405** may be about the same. Alternatively, the density of the interme-

tallic layer may be higher or lower than the density of the liquid metal cathode **405**. For example, the density of the intermetallic layer may be a function of the phase structure of the solid formed. As the cathode volume increases during discharging, individually, the intermetallic layer **410** may grow, but the liquid metal cathode **405** may be consumed. The intermetallic layer **410** may grow at the expense of the liquid metal cathode **405**. Alternatively, the volumes of both the intermetallic layer **410** and the liquid metal cathode **405** may increase, but the increase in volume of the liquid metal cathode **405** is less than it would otherwise be in the absence of an intermetallic layer. In some examples, the alloy in the liquid metal cathode **405**, and the alloy in the intermetallic layer **410** may be formed independently at the interfaces between the liquid metal electrolyte and the liquid metal cathode. Alternatively, the formation of the intermetallic layer **410** may consume alloy first formed in the liquid metal cathode **405**. The expansion of the liquid metal cathode **405** confined by an intermetallic layer **410**, and the sheath **406** or housing **401** may lead to hydraulic pressure buildup in the liquid metal cathode **405**.

[0095] With continued reference to FIG. 4, the intermetallic **410** can be located between the liquid metal electrolyte **404** and the liquid metal cathode **405**. During normal operation, the cell or battery **400** can be oriented in the direction shown in FIG. 4, such that any gravitational pull affecting the cell is oriented downward in the direction of the vector *y*. A hydrostatic pressure from the liquid metal electrolyte **404** may exert a downward force (in the direction of *y*) on the intermetallic layer **410**. This force may remain constant during discharge, as the mass of the liquid metal electrolyte may not change. The upper interface **410a** of the intermetallic layer may be stationary. As the intermetallic layer **410** grows, a hydraulic pressure may build up in the liquid metal cathode **405**, and may exert an upward force (in the opposite direction from *y*) on the intermetallic layer **410**.

[0096] In another aspect of the present disclosure, an energy storage device comprises at least one liquid metal electrode. The energy storage device can have a high energy storage capacity and a fast response time. The liquid metal electrode can be an anode or a cathode of the energy storage device. In some embodiments, the energy storage devices comprises a liquid metal anode (e.g., lithium, sodium, calcium, and/or potassium) and a liquid metal cathode (e.g., antimony, bismuth, tellurium, tin, and/or lead). The energy storage device can also comprise a liquid electrolyte. In some embodiments, the reactions that occur at the electrode and liquid metal electrode interfaces are extremely facile, permitting high current density operation with minimal electrode overpotentials and extremely fast response times.

[0097] The energy storage capacity can be any suitably large value (e.g., suitable for grid-scale energy storage), including about 1 kWh, about 10 kWh, about 20 kWh, about 30 kWh, about 100 kWh, about 500 kWh, about 1 MWh, about 5 MWh, about 10 MWh, about 50 MWh, about 100 MWh, and the like. In some embodiments, the energy storage capacity is at least about 1 kWh, at least about 10 kWh, at least about 20 kWh, at least about 30 kWh, at least about 100 kWh, at least about 500 kWh, at least about 1 MWh, at least about 5 MWh, at least about 10 MWh, at least about 50 MWh, at least about 100 MWh and the like.

[0098] The response time can be any suitable value (e.g., suitable for responding to disturbances in the power grid). In some instances, the response time is about 100 milliseconds

(ms), about 50 ms, about 10 ms, about 1 ms, and the like. In some cases, the response time is at most about 100 milliseconds (ms), at most about 50 ms, at most about 10 ms, at most about 1 ms, and the like.

[0099] In some embodiments, the liquid metal electrode comprises an alkali earth metal, a metalloid, or combinations thereof. In some embodiments, the liquid metal electrode comprises lithium, sodium, potassium, magnesium, calcium, or any combination thereof. In some cases, the liquid metal electrode comprises antimony, lead, tin, tellurium, bismuth or combinations thereof.

[0100] In some embodiments, the device is comprised in an array of energy storage devices as part of an energy storage system. The device can be an energy storage cell, and the energy storage system comprises a plurality of energy storage cells.

[0101] In another aspect of the present disclosure, an energy storage device comprises at least one liquid metal electrode stored in a container at a temperature greater than or equal to about 250° C. The energy storage device can have a high energy storage capacity and the container can have a surface area-to-volume ratio that is less than or equal to about 10 m⁻¹.

[0102] The energy storage capacity can be any suitable large value (e.g., suitable for grid-scale energy storage), including about 1 kWh, about 10 kWh, about 20 kWh, about 30 kWh, about 100 kWh, about 500 kWh, about 1 MWh, about 5 MWh, about 10 MWh, about 50 MWh, about 100 MWh, and the like. In some embodiments, the energy storage capacity is at least about 1 kWh, at least about 10 kWh, at least about 20 kWh, at least about 30 kWh, at least about 100 kWh, at least about 500 kWh, at least about 1 MWh, at least about 5 MWh, at least about 10 MWh, at least about 50 MWh, at least about 100 MWh and the like.

[0103] In some embodiments, the surface area-to-volume ratio is about 100 m⁻¹, about 50 m⁻¹, about 10 m⁻¹, about 1 m⁻¹, about 0.5 m⁻¹, about 0.1 m⁻¹, about 0.01 m⁻¹, or about 0.001 m⁻¹. In some cases, the surface area-to-volume ratio is less than about 100 m⁻¹, less than about 50 m⁻¹, less than about 10 m⁻¹, less than about 1 m⁻¹, less than about 0.5 m⁻¹, less than about 0.1 m⁻¹, less than about 0.01 m⁻¹, or less than about 0.001 m⁻¹.

[0104] The temperature can be any suitable temperature (e.g., for maintaining the electrodes in a molten state). In some embodiments, the at least one liquid metal electrode is stored in the container at a temperature greater than or equal to about 250° C., greater than or equal to about 400° C., greater than or equal to about 450° C. greater than or equal to about 500° C. or greater than or equal to about 550° C.

[0105] In another aspect of the present disclosure, an energy storage device comprises at least one liquid metal electrode and the energy storage device maintains at least 90% of its energy storage capacity after 100 charge/discharge cycles.

[0106] In some cases, the energy storage device has an energy storage capacity of at least about 1 kWh. In some embodiments, the energy storage device has an energy storage capacity of at least about 2 kWh, 3 kWh, 4 kWh, 5 kWh, 6 kWh, 7 kWh, 8 kWh, 9 kWh, 10 kWh, 20 kWh, 30 kWh, 100 kWh, 200 kWh, 300 kWh, 400 kWh, 500 kWh, 1 MWh, 5 MWh, or 10 MWh.

[0107] In some embodiments, the energy storage device maintains at least 90%, 95%, 96%, 97%, 98%, or 99% of its

energy storage capacity after 100, 200, 300, 400, 500, or 1000, 3000, 5000, 10,000 charge/discharge cycles.

[0108] In some embodiments, an energy storage device comprises at least one liquid metal electrode, where the device is transportable on a vehicle and has an energy storage capacity of at least about 1 kWh. The energy storage device is transportable with at least any two of an anode, cathode and electrolyte of the energy storage device in solid state.

[0109] An energy storage device can be transported if it has less than a certain weight. In some embodiments, the energy storage device has a weight of about 10 kg, 100 kg, 500 kg, 1,000 kg, 2,000 kg, 3,000 kg, 4,000 kg, 5,000 kg, 10,000 kg, or 50,000 kg. In some embodiments, an individual cell of the energy storage device has a weight of about 0.1 kg, 0.5 kg, 1 kg, 2 kg, 3 kg, 4 kg, 5 kg, 10 kg, 100 kg, 1,000 kg, or 10,000 kg. In some embodiments, the energy storage device has a weight of at least about 10 kg, 100 kg, 500 kg, 1,000 kg, 2,000 kg, 3,000 kg, 4,000 kg, 5,000 kg, 10,000 kg, or 50,000 kg. In some embodiments, an individual cell of the energy storage device has a weight of at least about 0.1 kg, 0.5 kg, 1 kg, 2 kg, 3 kg, 4 kg, 5 kg, 10 kg, 100 kg, 1,000 kg, or 10,000 kg.

[0110] In some embodiments, an energy storage device comprises a container containing one or more cells, an individual cell of the one or more cells containing at least one liquid metal electrode, where a rate of heat generation in the cell during charge/discharge is about equal to a rate of heat loss from the cell.

[0111] The rate of heat generation can be any suitable value compared to the rate of heat loss from the cell (e.g., such that the battery is self-heating and/or maintains a constant temperature). In some cases, the ratio of the rate of heat generation to the rate of heat loss from the cell is about 50%, about 75%, about 80%, about 85%, about 90%, about 100%, about 110%, about 120%, or about 150%. In some instances, the ratio of the rate of heat generation to the rate of heat loss from the cell is at least about 50%, at least about 75%, at least about 80%, at least about 85%, at least about 90%, at least about 100%, at least about 110%, at least about 120%, or at least about 150%. In some instances, the ratio of the rate of heat generation to the rate of heat loss from the cell is at most about 50%, at most about 75%, at most about 80%, at most about 85%, at most about 90%, at most about 100%, at most about 110%, at most about 120%, or at most about 150%.

[0112] In another aspect of the present disclosure, a separator-less energy storage device comprises a container with at least one liquid metal electrode, where the container has a surface area-to-volume ratio that is less than or equal to about 100 m⁻¹, and the separator-less energy storage device has (i) a response time less than or equal to about 100 milliseconds (ms), and/or (ii) an energy storage capacity of at least about 1 kWh. In some embodiments, the separator-less energy storage devices comprises (i) and (ii). In some embodiments, the separator-less energy storage device does not include a separator.

[0113] The energy storage capacity can be any suitably large value (e.g., suitable for grid-scale energy storage), including about 1 kWh, about 10 kWh, about 20 kWh, about 30 kWh, about 100 kWh, about 500 kWh, about 1 MWh, about 5 MWh, about 10 MWh, about 50 MWh, about 100 MWh, and the like. In some embodiments, the energy storage capacity is at least about 1 kWh, at least about 10 kWh, at least about 20 kWh, at least about 30 kWh, at least about 100 kWh, at least about 500 kWh, at least about 1 MWh, at least about

5 MWh, at least about 10 MWh, at least about 50 MWh, at least about 100 MWh, and the like.

[0114] The response time can be any suitable value (e.g., suitable for responding to disturbances in the power grid). In some instances, the response time is about 100 milliseconds (ms), about 50 ms, about 10 ms, about 1 ms, and the like. In some cases, the response time is at most about 100 milliseconds (ms), at most about 50 ms, at most about 10 ms, at most about 1 ms, and the like.

[0115] In some embodiments, the surface area-to-volume ratio is about 100 m^{-1} , about 50 m^{-1} , about 10 m^{-1} , about 1 m^{-1} , about 0.5 m^{-1} , about 0.1 m^{-1} , about 0.01 m^{-1} , or about 0.001 m^{-1} . In some cases, the surface area-to-volume ratio is less than about 100 m^{-1} , less than about 50 m^{-1} , less than about 10 m^{-1} , less than about 1 m^{-1} , less than about 0.5 m^{-1} , less than about 0.1 m^{-1} , less than about 0.01 m^{-1} , or less than about 0.001 m^{-1} .

[0116] In another aspect of the present disclosure, a method for forming an energy storage device comprises shipping a container comprising an energy storage material in solid state to a destination location, and at the destination location supplying energy to the energy storage material to form at least one of a liquid metal anode, liquid metal cathode, and liquid electrolyte, thereby forming the energy storage device.

[0117] In some instances, the energy storage material is not mixed during shipping. In some cases, the energy storage device does not include a separator. In some embodiments, during shipping, the energy storage material comprises at least one of a solid state anode, solid state cathode and solid state electrolyte.

[0118] In another aspect of the present disclosure, an energy storage system comprises: (a) a container comprising one or more energy storage cells, where an individual energy storage cell of the one or more energy storage cells comprises an energy storage material comprising at least one liquid metal electrode; and (b) a control system comprising a processor with machine-executable code for monitoring at least one temperature of the one or more energy storage cells and/or the container. The processor can regulate the flow of electrical energy into at least a subset of the one or more energy storage cells such that the energy storage material undergoes sustained self-heating during charge/discharge. In some embodiments, the container comprises a plurality of energy storage cells.

[0119] In some embodiments, the processor regulates one or more process parameters of the individual energy storage cell such that a rate of heat dissipation from the individual energy storage cell during charge/discharge is greater than a rate of heat loss from the individual energy storage cell. In some embodiments, at least one liquid metal electrode is stored in the container at a temperature greater than or equal to about 250°C ., greater than or equal to about 300°C ., greater than or equal to about 350°C ., greater than or equal to about 400°C ., greater than or equal to about 450°C ., greater than or equal to about 500°C . or greater than or equal to about 550°C .

[0120] Another aspect of the present disclosure provides a system that is programmed or otherwise configured to implement the methods of the disclosure. FIG. 5 shows a system 500 programmed or otherwise configured to one or more process parameters of an energy storage system. The system 500 includes a computer server (“server”) 501 that is programmed to implement methods disclosed herein. The server 501 includes a central processing unit (CPU, also “processor”

and “computer processor” herein) 505, which can be a single core or multi core processor, or a plurality of processors for parallel processing. The server 501 also includes memory 510 (e.g., random-access memory, read-only memory, flash memory), electronic storage unit 515 (e.g., hard disk), communication interface 520 (e.g., network adapter) for communicating with one or more other systems, and peripheral devices 525, such as cache, other memory, data storage and/or electronic display adapters. The memory 510, storage unit 515, interface 520 and peripheral devices 525 are in communication with the CPU 505 through a communication bus (solid lines), such as a motherboard. The storage unit 515 can be a data storage unit (or data repository) for storing data. The server 501 can be operatively coupled to a computer network (“network”) 530 with the aid of the communication interface 520. The network 530 can be the Internet, an internet and/or extranet, or an intranet and/or extranet that is in communication with the Internet. The network 530 in some cases is a telecommunication and/or data network. The network 530 can include one or more computer servers, which can enable distributed computing, such as cloud computing. The network 530, in some cases with the aid of the server 501, can implement a peer-to-peer network, which may enable devices coupled to the server 501 to behave as a client or a server. The server 501 can be coupled to an energy storage system 535 either directly or through the network 530.

[0121] The storage unit 515 can store process parameters of the energy storage system 535. The server 501 in some cases can include one or more additional data storage units that are external to the server 501, such as located on a remote server that is in communication with the server 501 through an intranet or the Internet.

[0122] The server 501 can communicate with one or more remote computer systems through the network 530. In the illustrated example, the server 501 is in communication with a remote computer system 540. The remote computer system 540 can be, for example, a personal computers (e.g., portable PC), slate or tablet PC (e.g., Apple® iPad, Samsung® Galaxy Tab), telephone, Smart phone (e.g., Apple® iPhone, Android-enabled device, Blackberry®), or personal digital assistant.

[0123] In some situations, the system 500 includes a single server 501. In other situations, the system 500 includes multiple servers in communication with one another through an intranet and/or the Internet.

[0124] Methods as described herein can be implemented by way of machine (or computer processor) executable code (or software) stored on an electronic storage location of the server 501, such as, for example, on the memory 510 or electronic storage unit 515. During use, the code can be executed by the processor 505. In some cases, the code can be retrieved from the storage unit 515 and stored on the memory 510 for ready access by the processor 505. In some situations, the electronic storage unit 515 can be precluded, and machine-executable instructions are stored on memory 510. Alternatively, the code can be executed on the second computer system 540.

[0125] The code can be pre-compiled and configured for use with a machine have a processor adapted to execute the code, or can be compiled during runtime. The code can be supplied in a programming language that can be selected to enable the code to execute in a pre-compiled or as-compiled fashion.

[0126] Aspects of the systems and methods provided herein, such as the server 501, can be embodied in program-

ming. Various aspects of the technology may be thought of as “products” or “articles of manufacture” typically in the form of machine (or processor) executable code and/or associated data that is carried on or embodied in a type of machine readable medium. Machine-executable code can be stored on an electronic storage unit, such memory (e.g., read-only memory, random-access memory, flash memory) or a hard disk. “Storage” type media can include any or all of the tangible memory of the computers, processors or the like, or associated modules thereof, such as various semiconductor memories, tape drives, disk drives and the like, which may provide non-transitory storage at any time for the software programming. All or portions of the software may at times be communicated through the Internet or various other telecommunication networks. Such communications, for example, may enable loading of the software from one computer or processor into another, for example, from a management server or host computer into the computer platform of an application server. Thus, another type of media that may bear the software elements includes optical, electrical and electromagnetic waves, such as used across physical interfaces between local devices, through wired and optical landline networks and over various air-links. The physical elements that carry such waves, such as wired or wireless links, optical links or the like, also may be considered as media bearing the software. As used herein, unless restricted to non-transitory, tangible “storage” media, terms such as computer or machine “readable medium” refer to any medium that participates in providing instructions to a processor for execution.

[0127] Hence, a machine readable medium, such as computer-executable code, may take many forms, including but not limited to, a tangible storage medium, a carrier wave medium or physical transmission medium. Non-volatile storage media include, for example, optical or magnetic disks, such as any of the storage devices in any computer(s) or the like, such as may be used to implement the databases, etc. shown in the drawings. Volatile storage media include dynamic memory, such as main memory of such a computer platform. Tangible transmission media include coaxial cables; copper wire and fiber optics, including the wires that comprise a bus within a computer system. Carrier-wave transmission media may take the form of electric or electromagnetic signals, or acoustic or light waves such as those generated during radio frequency (RF) and infrared (IR) data communications. Common forms of computer-readable media therefore include for example: a floppy disk, a flexible disk, hard disk, magnetic tape, any other magnetic medium, a CD-ROM, DVD or DVD-ROM, any other optical medium, punch cards paper tape, any other physical storage medium with patterns of holes, a RAM, a ROM, a PROM and EPROM, a FLASH-EPROM, any other memory chip or cartridge, a carrier wave transporting data or instructions, cables or links transporting such a carrier wave, or any other medium from which a computer may read programming code and/or data. Many of these forms of computer readable media may be involved in carrying one or more sequences of one or more instructions to a processor for execution.

[0128] Various parameters of an energy storage system can be presented to a user on a user interface (UI) of an electronic device of the user. Examples of UI's include, without limitation, a graphical user interface (GUI) and web-based user interface. The UI (e.g., GUI) can be provided on a display of an electronic device of the user. The display can be a capaci-

tive or resistive touch display. Such displays can be used with other systems and methods of the disclosure.

[0129] Methods of the disclosure can be facilitated with the aid of applications (apps) that can be installed on electronic devices of a user. An app can include a GUI on a display of the electronic device of the user. The app can be programmed or otherwise configured to perform various functions of the system.

Methods for Transporting Energy Storage Systems

[0130] Another aspect of the present disclosure provides methods for transporting energy storage systems. In some cases, the energy storage devices are transported with molten metal electrodes (e.g., at a high temperature of at least 250° C., at least 400° C., at least 500° C., or at least 600° C.). The energy storage devices can also be transported at ambient temperature (e.g., with the electrodes being solid and not molten) and heated at the site of operation to melt the metal electrodes.

[0131] The energy storage devices can be transported in any suitable manner including fully assembled or in pieces to be assembled at the site of operation. The energy storage devices can be transported on any suitable vehicle, such as a truck (including on a trailer pulled by a truck), on a train, on a ship, on an airplane, on a helicopter, by a robot, and the like. FIG. 6 shows an energy storage device 605 that is assembled 600 and placed on a vehicle 610. In this case the vehicle includes a truck 615 and a trailer 620 pulled by the truck. The vehicle can transport the energy storage device 625 from an initial location 630 to a site of installation and/or operation 635 along any suitable path (e.g., along roads, railroad tracks, shipping routes and the like).

[0132] The energy storage devices can be transported any distance such as at least about 1 mile, at least about 10 miles, at least about 100 miles, at least about 1,000 miles or at least about 10,000 miles. The energy storage devices can be transported at any speed including at least about 5 miles per hour (mph), at least about 10 mph, at least about 20 mph, at least about 40 mph, at least about 60 mph, at least about 150 mph, or at least about 500 mph.

[0133] An energy storage device of the present disclosure, including an electrochemical cell (“cell”) of the energy storage device, can be configured for transport. In some cases, the cell does not have a voltage and cannot pass current while being transported (e.g., on a truck at room temperature). The cell may not have an appreciable or detectable voltage during transport, and the cell may not pass an appreciable or detectable current during transport. This can be advantageous since the cells are electrically inert and cannot short.

[0134] An electrochemical cell can comprise chemical components that generate a potential difference when a system comprising the cell is heated (e.g., to approximately 250° C. or 450° C. or 500° C.). While at room temperature, the electrolyte in the cell can be solid and/or incapable of conducting ions necessary to facilitate either the charge or discharge reactions. The system does not pass current (e.g., even if the electrode terminals are shorted), and does not have an inherent cell voltage. When the temperature is elevated, the non-aqueous (non water based) electrolyte melts and/or becomes an ionic conductor, thus enabling the cell to accept or provide current and charge or discharge. When at operating temperature and when the electrolyte is molten or ionically

conductive and if the cell is above 0% state of charge, the battery can have a non-zero cell voltage of around 0.9 volts in some cases.

[0135] An advantage of a cell that does not exhibit a cell voltage and is unable to accept or supply current while at room temperature is that the safety risks associated with shipping batteries are reduced. Even in the event that the cells are jostled and are externally shorted, the cells do not discharge and cannot be charged.

[0136] In some cases, the system comprises a metallic crucible that acts as one electrode and a dielectrically separated region that forms the second electrode. At room temperature, the electrodes are physically separated by solid chemicals that are inert and do not inherently generate a potential between the two electrodes. As temperature is raised portions of the solid electrolyte can undergo a change in electrical characteristics (such as a phase transition) that results in a potential difference forming between the electrodes. When temperature is maintained at approximately this range, the system can be capable of sourcing (discharging) or sinking (recharging) current. When the temperature is brought back to room temperature, the chemical media can undergo another phase transition that brings potential difference to zero between the electrodes and also increases ionic resistance preventing flow of current.

[0137] Energy storage devices (or batteries) of the present disclosure can be reliably safe during transportation and handling from a pickup location to a delivery location. Physical short circuits or other externally induced abuse conditions (e.g., puncture, shock, vibration, etc.) have little to no effect on safety or operation of the system when these conditions are induced at room temperature.

[0138] An electrochemical energy storage device of the present disclosure (including a cell of the device) may not be capable of being charged, being discharged, or having an electrical potential during transport. This may be accomplished by transporting (or shipping) the energy storage device at a temperature that is reduced with respect to an operating temperature of the energy storage device.

[0139] For example, an electrochemical energy storage device can comprise an anode and a cathode, and an electrolyte between the anode and the cathode. The device may not be capable of conducting ions at a first temperature and capable of conducting ions at a second temperature. The first temperature may be maintained during transport of the electrochemical energy storage device.

[0140] The anode can comprise lithium, potassium, magnesium and/or calcium. The cathode can comprise antimony, tin, tellurium, bismuth and/or lead.

[0141] In some embodiments, at least part of the device is a solid at the first temperature and a liquid at the second temperature. The at least part of the device can be an electrolyte.

[0142] In some cases, the first temperature is room temperature. In some cases, the first temperature is less than about 100° C. In some cases, the second temperature is at least about 250° C. In some cases, the second temperature is at least about 500° C.

[0143] The device of the present disclosure may not be capable of being charged, being discharged, or having an electrical potential at the first temperature. In some instances, the device has a positive terminal and a negative terminal, and shorting the terminals does not discharge the device at the first temperature. In some cases, the device does not discharge when the device is punctured, vibrated, shorted, or shocked.

[0144] In another aspect of the present disclosure, an electrochemical energy storage device comprises a negative electrode and a positive electrode, and an electrolyte between the negative and positive electrodes. The device has a first potential difference between the electrodes at a first temperature of less than about 50° C. and a second potential difference between the electrodes at a second temperature of at least about 250° C. The second potential difference is greater than the first potential difference.

[0145] In some cases, the first potential difference is less than or equal to about 2.5 volts, 2 volts, 1.5 volts, 1.2 volts, 1 volt, 0.9 volts, 0.8 volts, 0.7 volts, 0.6 volts, 0.5 volts, 0.4 volts, 0.3 volts, 0.2 volts, 0.1 volts, or less. The first potential difference can be about 0 volts.

[0146] The second voltage can be greater than 0 volts, or greater than or equal to about 0.1 volts, 0.2 volts, 0.3 volts, 0.4 volts, 0.5 volts, 0.6 volts, 0.7 volts, 0.8 volts, 0.9 volts, 1 volt, 1.2 volts, 1.5 volts, 2 volts, or 2.5 volts.

[0147] The negative electrode can comprise lithium, potassium, magnesium and/or calcium. The positive electrode can comprise antimony, tin, tellurium, bismuth and/or lead.

[0148] The electrochemical energy storage device of the present disclosure can be comprised in an array of energy storage devices as part of an energy storage system. In some cases, the electrochemical energy storage device is an energy storage cell, and the energy storage system comprises a plurality of energy storage cells.

[0149] The present disclosure provides methods for transporting energy storage devices, and installing the energy storage devices for use in an energy storage system. The energy storage system can be electrically coupled to a power source and a load, such as, for example, a power grid. The energy storage system can store energy from the power source for use with the load.

[0150] FIG. 7 illustrates a method 700 for forming an energy storage system of the present disclosure. The method 700 comprises, in a first operation 701, forming, at a first location, an energy storage device comprising a negative electrode and a positive electrode, and an electrolyte between the negative electrode and the positive electrode, and placing the energy storage device on a vehicle (e.g., truck, train) that is configured to transport the energy storage device from the first location to a second location. The energy storage device can be as described elsewhere herein. For instance, the negative electrode, positive electrode and electrolyte can each be formed of a material that is in the liquid at an operating temperature of the energy storage device.

[0151] Next, in a second operation 702, the method 700 comprises using the vehicle to transport the energy storage device from the first location to the second location. Next, in a third operation 703, at the second location the energy storage device can be removed from the vehicle. The energy storage device can be subsequently positioned at an installation location, and in some cases installed into the energy storage system at the installation location.

[0152] In some examples, the energy storage device can be electrically coupled to a power source. The power source can be selected from the group consisting of a power plant (e.g., nuclear power plant, coal-fired power plant, fuel-fired power plant), a wind turbine, a photovoltaic system, a geothermal system, and a wave energy system. The power source can be configured to generate power from a renewable energy source or non-renewable energy source.

[0153] The energy storage device of the present disclosure can be electrically coupled to a load, such as a power grid. The energy storage device can then be employed to deliver power to the load and/or store energy from the power source.

[0154] During transport, a potential difference between the positive electrode and the negative electrode can be less than about 1 volt, 0.9 volts, 0.8 volts, 0.7 volts, 0.6 volts, 0.5 volts, 0.4 volts, 0.3 volts, 0.2 volts, 0.1 volts, or less. In some examples, the potential difference can be about 0 volts. The potential difference can be less than 1 volt, 0.9 volts, 0.8 volts, 0.7 volts, 0.6 volts, 0.5 volts, 0.4 volts, 0.3 volts, 0.2 volts, 0.1 volts, or less (e.g., 0 volts) at a temperature (“transport temperature”) that is less than the operating temperature of the energy storage device. The energy storage device can be transported with the energy storage device at the transport temperature.

Liquid Metal Electrochemical Energy Storage Devices

[0155] Electrochemical cells having molten electrodes having an alkali metal can provide receipt and delivery of power by transporting atoms of the alkali metal between electrode environments of disparate chemical potentials through an electrochemical pathway comprising a salt of the alkali metal. The chemical potential of the alkali metal is decreased when combined with one or more non-alkali metals, thus producing a voltage between an electrode comprising the molten alkali metal and the electrode comprising the combined alkali/non-alkali metals. Additional details of the batteries can be found in U.S. Patent Publication No. 2012/0104990, which is hereby incorporated by reference in its entirety.

[0156] In some cases, an electrochemical cell has three distinct phases. The first phase defines a positive electrode having at least one element other than an alkali metal. The second phase includes cations of the alkali metal, and defines two separate interfaces. The first phase is in contact with the second phase at one of the interfaces. The third phase defines a negative electrode and includes the alkali metal. It is separate from the first phase and in contact with the second phase at the other interface. The first and third phases have respective volumes which decrease or increase at the expense of one another during operation of the cell. As a result the second phase is displaced from a first position to a second position. The first, second, and third phases may be solid, liquid, or in a combination of solid or liquid states. In preferred embodiments, the alkali metal is present at respective disparate chemical potentials in the first and third phases, originating a voltage between the first and third phases.

[0157] An embodiment includes an electrochemical cell having two distinct phases. The first phase defines a positive electrode and includes an alkali metal, and two other elements other than the alkali metal. The second liquid phase includes cations of the alkali metal, and defines two separate interfaces. The first phase is in contact with the second phase at one of the interfaces. In some embodiments, the first and second phases are solid. In other embodiments, the first and second phases are liquid. In other embodiments, the phases are in a combination of solid or liquid states. The alkali metal preferably is selected to exhibit a change in chemical potential when combined with the first and second elements. During operation of the cell to deliver or draw electrical energy to drive transfer of the alkali metal to or from the second liquid phase to or from the first liquid phase, the first phase has a volume which increases or decreases thus transferring energy

to or from the electrochemical cell to or from an external circuit. As a result the second phase is displaced from a first position to a second position.

[0158] In some cases, the two elements other than the alkali metal are independently selected from group WA, VA and VIA elements of the chemical periodic table. In some embodiments, these elements are selected independently from one of tin, lead, bismuth, antimony, tellurium and selenium. In other embodiments, these elements are lead and antimony. The alkali metal may be sodium or lithium or potassium. The second phase may include refractory particles distributed throughout the second liquid phase. Moreover, the refractory particles may include a metal oxide or metal nitride, or combinations thereof.

[0159] The second phase can include a salt of the alkali metal. The salt of the alkali metal may be selected from one or more of halide, bistriflimide, fluorosulfano-amine, perchlorate, hexafluorophosphate, tetrafluoroborate, carbonate or hydroxide.

[0160] In some instances, a method stores electrical energy transferred from an external circuit. To that end, the method provides at least one electrochemical cell having three liquid phases. The first liquid phase defines a positive electrode and includes at least one element other than an alkali metal. The second liquid phase includes cations of the alkali metal, and defines two separate interfaces. The first phase is in contact with the second phase at one of the interfaces. The third liquid phase defines a negative electrode and includes the alkali metal. It is separate from the first phase and in contact with the second phase at the other interface. The electrochemical cell is configured to connect with the external circuit. The external circuit is electrically connected to a negative pole and a positive pole of electrochemical cell. The external circuit is operated which drives electrical energy that drives transfer of the alkali metal to or from the first liquid phase, through the second liquid phase, and to or from the third liquid phase. The first phase has a volume which decreases or increases while the third phase has a volume which decreases or increases respectively thus transferring energy to and from the external circuit to the electrochemical cell. As a result the second phase is displaced from a first position to a second position.

[0161] A method of the present disclosure can release electrical energy from the electrochemical cell to an external circuit. The method includes providing at least one electrochemical cell having three liquid phases. The first liquid phase defines a positive electrode and includes two elements other than an alkali metal. The second liquid phase includes cations of the alkali metal, and defines two separate interfaces. The first phase is in contact with the second phase at one of the interfaces. The third liquid phase defines a negative electrode and includes the alkali metal. It is separate from the first phase and in contact with the second phase at the other interface. The electrochemical cell is configured to connect sequentially with external circuits. The external circuits are electrically connected to a negative pole and a positive pole of electrochemical cell. The external circuits are sequentially operated to drive electrical energy to drive transfer of the alkali metal to or from the third liquid phase, through the second liquid phase, and to or from the first liquid phase, the first phase has a volume which increases or decreases while the third phase has a volume which decreases or increases respectively thus transferring energy to or from the electro-

chemical cell to or from the external circuits. As a result the second phase is displaced from a first position to a second position.

[0162] An electrochemical method and apparatus of the present disclosure for high-amperage electrical energy storage can feature a high-temperature, all-liquid chemistry. The reaction products created during charging can remain part of the electrodes during storage for discharge on demand. In a simultaneous ambipolar electrodeposition cell, a reaction compound can be electrolyzed to effect transfer from an external power source. The electrode elements are electrochemically dissolved during discharge. Additional details of the liquid metal batteries can be found in U.S. Patent Publication No. 2008/0044725, which is herein incorporated by reference in its entirety.

[0163] Electrochemical cells of the present disclosure having molten electrodes comprising an alkaline earth metal can provide receipt and delivery of power by transporting atoms of the alkaline earth metal between electrode environments of disparate alkaline earth metal chemical potentials. Additional details of the alkaline earth metal batteries can be found in U.S. Patent Publication No. 2011/0014503, which is herein incorporated by reference in its entirety.

[0164] In another aspect of the present disclosure, an energy storage device comprises at least one electrochemical cell having an operating temperature, the at least one electrochemical cell comprising: (a) a liquid negative electrode comprising a first metal; (b) a liquid electrolyte adjacent to the liquid negative electrode; and (c) a liquid positive electrode adjacent to the liquid electrolyte, the liquid positive electrode comprising a second elemental metal that is different than the first metal. The liquid electrolyte can comprise a charged species of the first metal and an oppositely charged species of the second metal, and the energy storage device is capable of being transported on a truck.

[0165] The first metal and/or the second metal can be an elemental metal (i.e., not an alloy or compound).

[0166] In another aspect of the present disclosure, an energy storage device comprises a first material and a second material, where the materials are liquid at the operating temperature of the device, the materials conduct electricity, the materials have different densities and the materials react with each other to form a mutual reaction compound, and the energy storage device is capable of being transported on a truck.

[0167] In some instances, the electrolyte has a free energy of formation more negative than that of the mutual reaction compound. In some embodiments, the electrolyte further comprises additives that lower the melting temperature of the electrolyte, reduce the viscosity of the electrolyte, enhance ionic conductivity through the electrolyte, inhibit electronic conductivity through the electrolyte or any combination thereof.

[0168] The first material or second material can further comprise additives that enable electrochemical monitoring of the extent of discharge of the device.

[0169] In another aspect of the present disclosure, an energy storage device comprises a molten salt, where a liquid electronic conductor is extracted from the molten salt by oxidation and metal is extracted from the molten salt by reduction and the energy storage device is capable of being transported on a truck.

[0170] In some cases, the liquid electronic conductor is antimony. In some embodiments, the liquid electronic metal is magnesium.

[0171] In another aspect of the present disclosure, an electrometallurgical cell comprises a positive electrode and a negative electrode, where the electrodes are liquid, the reactants of reactions that occur at the electrodes are liquid, and the products of reactions that occur at the electrodes are liquid, and where the electrometallurgical cell is capable of being transported on a truck.

[0172] In some cases, an electrode comprises a material and a reaction that occurs at the electrode produces the material, thereby enlarging the electrode. In some embodiments, an electrode comprises a material and a reaction that occurs at the electrode consumes the material, thereby consuming the electrode. In some embodiments, the electrodes do not comprise a solid.

[0173] The products of reactions that occur at the electrodes may not comprise a gas. In some embodiments, the cell has a current density of at least 100 mA/cm² and an efficiency of at least 60%, at least 70%, at least 80%, or at least 90%.

[0174] In another aspect of the present disclosure, an energy storage device capable of being transported on a truck and having a power capacity of greater than 1 MW comprises: (a) a physical footprint smaller than about 100 m²/MW; (b) a cycle life greater than 3000 deep discharge cycles; (c) a lifespan of at least 10 years; (d) a DC-to-DC efficiency of at least 65%; (e) a discharge capacity of at most 10 hours; and (f) a response time of less than 100 milliseconds.

[0175] The energy storage device of the present disclosure may comprise a liquid metal. In some cases, the device comprises a liquid metal anode, a liquid metal cathode, and a liquid metal electrolyte. The device can be transported with some or all of the anode, cathode and electrolyte being in the solid state.

[0176] In another aspect of the present disclosure, an energy storage device comprises a liquid electrode, the electrode comprising an additive, where the electrode is consumed and the additive is concentrated by operation of the device, and where a property of the device is determined by of the concentration of the additive, and where the energy storage device is capable of being transported on a truck.

[0177] In some cases, the property of the device is the extent of discharge of the device. In some embodiments, the additive comprises lead. In some embodiments, the open voltage of the cell drops when the additive is concentrated.

[0178] In another aspect of the present disclosure, an energy storage device comprises a liquid antimony electrode, a steel container and a layer of iron antimonide disposed therebetween, where the device is operated at less than 738° C., and where the energy storage device is capable of being transported on a truck.

[0179] In some instances, the iron antimonide is electronically conductive and protects the steel from corrosion.

[0180] In another aspect of the present disclosure, an energy storage device comprises a liquid electrode and a current collector in contact with the electrode, where the liquid electrode is consumed in a reaction during operation of the device, and where the amount of liquid electrode is in stoichiometric excess relative to other reactants of the reaction such that the current collector is in contact with the liquid electrode when the reaction has proceeded to completion, and where the energy storage device is capable of being transported on a truck.

[0181] The current collector can be a negative current collector and the reaction comprises discharging the device.

[0182] In another aspect of the present disclosure, an energy storage device comprises an alkaline earth metal present in each of a positive electrode, a negative electrode and a liquid electrolyte, where the energy storage device is capable of being transported on a truck.

[0183] In some instances, the alkaline earth metal is at three disparate chemical potentials in the positive electrode, the negative electrode and the liquid electrolyte. In some cases, the alkaline earth metal is a halide in the electrolyte. In some instances, the alkaline earth metal is an alloy in the positive electrode. In some cases, the alkaline earth metal is elemental in the negative electrode.

[0184] In another aspect of the present disclosure, an energy storage device comprises an alkaline earth metal present in each of an elemental form, an alloy form and a halide form, where the energy storage device is capable of being transported on a truck.

[0185] In some cases, the elemental form (e.g., not alloyed or a salt) is found in a negative electrode of the device. In some embodiments, the alloy form is found in a positive electrode of the device. In some embodiments, the halide form (e.g., chloride salt) is found in an electrolyte of the device.

[0186] In another aspect of the present disclosure, an energy storage device comprises a liquid anode, a liquid cathode and a liquid electrolyte disposed therebetween, where the thickness of the electrolyte is substantially constant through a charge-discharge cycle of the device, and the energy storage device is capable of being transported on a truck. The thickness can vary by any suitable amount during the operation of the device including varying by less than 20%, less than 10%, less than 5%, or less than 2%.

[0187] In another aspect of the present disclosure, an energy storage device comprises a liquid anode, a liquid cathode and a liquid electrolyte disposed therebetween, where the thickness of the electrolyte is less than 50% of the thickness of the cathode or the anode, and the energy storage device is capable of being transported on a truck.

[0188] In another aspect of the present disclosure, an energy storage device comprises a liquid anode, a liquid cathode, a liquid electrolyte, and a circulation producer configured to generate circulation within at least one of the liquids, where the energy storage device is capable of being transported on a truck.

[0189] In some embodiments, the temperature inside the device is greater than the temperature outside the device and the circulation producer is a thermally conductive material extending from the inside of the device to the outside of the device.

[0190] In another aspect of the present disclosure, an energy storage device comprises a liquid electrode comprising an elemental alkaline earth metal and an electrolyte comprising a halide of the alkaline earth metal, where the electrolyte further comprises complexing ligands, and the energy storage device is capable of being transported on a truck.

[0191] The complexing ligands can reduce the solubility of the elemental alkaline earth metal in the halide of the alkaline earth metal.

[0192] In another aspect of the present disclosure, an energy storage device comprises a conductive housing comprising a conductive liquid anode, a conductive liquid cathode and an electrolyte disposed therebetween, where the interior

surface of the container is not electrically insulated, and the energy storage device is capable of being transported on a truck.

[0193] In some cases, the device further comprises an electrically conductive structure that holds the conductive liquid anode or the conductive liquid cathode away from the interior surface of the container. In some cases, the conductive liquid anode or the conductive liquid cathode is associated with the structure at least in part by surface tension forces.

[0194] In another aspect of the present disclosure, an energy storage device comprises an anode comprising a first electronically conductive liquid and a cathode comprising a second electronically conductive liquid, where the device is configured to impede mixing of the electronically conductive liquids, and the energy storage device is capable of being transported on a truck.

[0195] In some instances, the electronically conductive liquids do not mix when the device is shaken or tipped. In some cases, the device further comprises an electrode separator disposed between the electronically conductive liquids. In some instances, the device further comprises a liquid electrolyte, the liquid electrolyte wets the electrode separator, and the electronically conductive liquids do not wet the separator. In some embodiments, the electrode separator floats in or on the electrolyte when the device is charged or discharged.

[0196] In another aspect of the present disclosure, an energy storage device comprises a negative electrode comprising an alkali metal, a positive electrode comprising the alkali metal and one or more additional elements and a liquid electrolyte disposed between the electrodes, where the electrolyte is not depleted upon charging or discharging of the device, and the energy storage device is capable of being transported on a truck.

[0197] At least one of the electrodes can be liquid at an operating temperature of the device. In some cases, the positive electrode comprises at least two additional elements such that the positive electrode comprises at least two elements when the positive electrode is fully depleted of the alkali metal. In some instances, the alkali metal is lithium, sodium, potassium, or any combination thereof.

[0198] In some cases, the one or more additional elements form an alloy with the alkali metal or exist in a compound with the alkali metal at an operating temperature of the device. In some embodiments, the one or more additional elements have a lower electronegativity than the alkali metal. In some instances, the electrolyte comprises a salt of the alkali metal. The operating temperature of the device is any suitable temperature such that the electrodes are molten (e.g., less than 600° C.).

[0199] In another aspect of the present disclosure, an energy storage device comprises a liquid metal electrode, a second metal electrode that can be a liquid and an electrolyte disposed between the electrodes, where the electrolyte is a paste, and the energy storage device is capable of being transported on a truck.

[0200] In another aspect of the present disclosure, an energy storage device comprises a liquid negative electrode comprising an alkali metal, a liquid positive electrode comprising an alloy of the alkali metal and an electrolyte disposed between the electrodes, where the electrolyte comprises a salt of the alkali metal and particles and the energy storage device is capable of being transported on a truck.

[0201] The particles can comprise alumina or magnesia. In some cases, the electrolyte is a paste.

[0202] In another aspect of the present disclosure, an energy storage device comprises a metal anode, a metal cathode and an electrolyte disposed between the electrodes, where the anode, cathode and electrolyte are liquids at an operating temperature of the device and the operating temperature of the device is less than 500° C., and the energy storage device is capable of being transported on a truck.

[0203] In some cases, the operating temperature of the device is less than 250° C.

[0204] In another aspect of the present disclosure, a method for charging an energy storage device comprises connecting an external charging circuit to terminals of the energy storage device that is capable of being transported on a truck such that an active alkali metal moves from a positive electrode, through an electrolyte, to a negative electrode comprising a metal having a higher chemical potential than the positive electrode.

[0205] In some instances, the active alkali metal is lithium, sodium, potassium, or any combination thereof.

[0206] In another aspect of the present disclosure, a method for discharging an energy storage device comprises connecting an external load to terminals of the energy storage device that is capable of being transported on a truck such that an active alkali metal moves from a negative electrode, through an electrolyte as cations, to a positive electrode where the active alkali metal forms a neutral metal having a lower chemical potential than the negative electrode.

[0207] In some cases, the active alkali metal is lithium, sodium, potassium, or any combination thereof.

[0208] In another aspect of the present disclosure, an energy storage device comprises a liquid metal electrode, an electrolyte and a current collector in contact with the electrode, where the current collector comprises a material that has a higher wettability with the liquid metal than with the electrolyte. In some embodiments, the material is a foam.

[0209] Energy storage devices of the present disclosure may be used in grid-scale settings or stand-alone settings. Energy storage device of the disclosure can, in some cases, be used to power vehicles, such as scooters, motorcycles, cars, trucks, trains, helicopters, airplanes, and other mechanical devices, such as robots.

[0210] Systems, apparatuses and methods of the disclosure may be combined with or modified by other systems, apparatuses and/or methods, such as batteries and battery components described, for example, in U.S. Pat. No. 3,663,295 (“STORAGE BATTERY ELECTROLYTE”), U.S. Pat. No. 8,268,471 (“HIGH-AMPERAGE ENERGY STORAGE DEVICE WITH LIQUID METAL NEGATIVE ELECTRODE AND METHODS”), U.S. Patent Publication No. 2011/0014503 (“ALKALINE EARTH METAL ION BATTERY”), U.S. Patent Publication No. 2011/0014505 (“LIQUID ELECTRODE BATTERY”), U.S. Patent Publication No. 2012/0104990 (“ALKALI METAL ION BATTERY WITH BIMETALLIC ELECTRODE”), and U.S. patent application Ser. No. 13/801,333 (“ELECTROCHEMICAL ENERGY STORAGE DEVICES”), filed on Mar. 13, 2013, which are entirely incorporated herein by reference.

[0211] It is to be understood that the terminology used herein is used for the purpose of describing specific embodiments, and is not intended to limit the scope of the present invention. It should be noted that as used herein, the singular forms of “a”, “an” and “the” include plural references unless the context clearly dictates otherwise. In addition, unless defined otherwise, all technical and scientific terms used

herein have the same meaning as commonly understood by one of ordinary skill in the art to which this invention belongs.

[0212] It should be understood from the foregoing that, while particular implementations have been illustrated and described, various modifications can be made thereto and are contemplated herein. It is also not intended that the invention be limited by the specific examples provided within the specification. While the invention has been described with reference to the aforementioned specification, the descriptions and illustrations of the preferable embodiments herein are not meant to be construed in a limiting sense. Furthermore, it shall be understood that all aspects of the invention are not limited to the specific depictions, configurations or relative proportions set forth herein which depend upon a variety of conditions and variables. Various modifications in form and detail of the embodiments of the invention will be apparent to a person skilled in the art. It is therefore contemplated that the invention shall also cover any such modifications, variations and equivalents. It is intended that the following claims define the scope of the invention and that methods and structures within the scope of these claims and their equivalents be covered thereby.

1. An electrochemical energy storage device comprising a container including a negative electrode, a positive electrode and an electrolyte disposed between the negative electrode and positive electrode, wherein the electrochemical energy storage device has a first potential difference between the negative electrode and positive electrode at a first temperature that is less than about 50° C. and a second potential difference between the negative electrode and positive electrode at a second temperature of at least about 250° C., wherein the second potential difference is greater than the first potential difference, wherein at least two of the positive electrode, electrolyte and negative electrode are liquid at the second temperature, wherein the container has a surface area-to-volume ratio of less than or equal to about 100 m⁻¹, and wherein the electrochemical energy storage device maintains at least about 90% of its energy storage capacity after 500 charge/discharge cycles.

2. The electrochemical energy storage device of claim 1, wherein the container contains one or more electrochemical cells, and wherein an individual electrochemical cell of the one or more electrochemical cells includes the negative electrode, the positive electrode and the electrolyte.

3. The electrochemical energy storage device of claim 2, wherein, over the charge/discharge cycle, a rate of heat generation in the individual electrochemical cell is greater than or equal to about 50% of a rate of heat loss from the individual electrochemical cell.

4. The electrochemical energy storage device of claim 1, wherein the electrochemical energy storage device maintains at least about 90% of its energy storage capacity after 1,000 charge/discharge cycles.

5. An energy storage system, comprising:

a container comprising one or more energy storage cells, wherein an individual energy storage cell of the one or more energy storage cells comprises at least one liquid electrode; and

a control system comprising a computer processor that is programmed to monitor at least one operating temperature of the one or more energy storage cells and/or the container, wherein the computer processor regulates a flow of electrical energy into at least a subset of the one

or more energy storage cells such that the subset undergoes sustained self-heating over a charge/discharge cycle.

6. The energy storage system of claim 5, wherein, over the charge/discharge cycle, a rate of heat generation in the individual energy storage cell is greater than or about equal to a rate of heat loss from the individual energy storage cell.

7. The energy storage system of claim 5, wherein, over the charge/discharge cycle, a rate of heat generation in the individual energy storage cell is less than or equal to about 150% of a rate of heat loss from the individual energy storage cell.

8. The energy storage system of claim 5, wherein the computer processor monitors the at least one operating temperature and regulates the flow of electrical energy such that the at least one operating temperature is greater than or equal to about 250° C. and the at least one liquid electrode is maintained as a liquid.

9. The energy storage system of claim 5, wherein the computer processor monitors the at least one operating temperature and regulates the flow of electrical energy such that over the charge/discharge cycle, the at least one operating temperature is greater than or equal to about 250° C.

10. The energy storage system of claim 5, wherein the at least one liquid electrode comprises (i) lithium, sodium, potassium, magnesium, calcium, or any combination thereof, or (ii) antimony, lead, tin, tellurium, bismuth, or any combination thereof.

11. The energy storage system of claim 5, wherein the individual energy storage cell further comprises an electrolyte adjacent to the at least one liquid electrode.

12. (canceled)

13. The energy storage system of claim 5, wherein the one or more energy storage cells maintain at least about 90% of their energy storage capacity after at least 100 charge/discharge cycles.

14. (canceled)

15. The energy storage system of claim 13, wherein the individual energy storage cell has an efficiency of at least about 80%.

16. (canceled)

17. The energy storage system of claim 15, wherein the individual energy storage cell has an efficiency of at least about 90%.

18. The energy storage system of claim 17, wherein the individual energy storage cell has an efficiency of at least about 90% at a current density of at least about 100 mA/cm².

19. An energy storage device comprising a negative electrode, a positive electrode and an electrolyte disposed

between the negative electrode and positive electrode, wherein at least one of the positive electrode and negative electrode is liquid at an operating temperature of the energy storage device that is greater than a non-operating temperature of the energy storage device, wherein the energy storage device maintains at least about 90% of its energy storage capacity after 500 charge/discharge cycles, and wherein the energy storage device has an efficiency of at least about 80% at a current density of at least about 100 mA/cm².

20. The energy storage device of claim 19, wherein the energy storage device maintains at least about 95% of its energy storage capacity after 500 charge/discharge cycles.

21. The energy storage device of claim 19, wherein the energy storage device maintains at least about 90% of its energy storage capacity after 1,000 charge/discharge cycles.

22. The energy storage device of claim 21, wherein the energy storage device maintains at least about 98% of its energy storage capacity after 1,000 charge/discharge cycles.

23. The energy storage device of claim 19, wherein the positive electrode, negative electrode and electrolyte are in a container that has a surface area-to-volume ratio that is less than or equal to about 100 m⁻¹.

24. The energy storage device of claim 19, wherein the operating temperature is greater than or equal to about 250° C.

25. The energy storage device of claim 19, wherein the energy storage device has an energy storage capacity of at least about 1 kWh.

26. (canceled)

27. The energy storage device of claim 19, wherein a response time of the energy storage device is less than or equal to about 100 milliseconds (ms).

28. The energy storage device of claim 19, wherein the energy storage device comprises a liquid negative electrode.

29. (canceled)

30. The energy storage device of claim 19, wherein the positive electrode, electrolyte and negative electrode are liquid at the operating temperature of the energy storage device.

31. (canceled)

32. The energy storage device of claim 19, wherein (i) the negative electrode comprises lithium, sodium, potassium, magnesium, calcium, or any combination thereof, or (ii) the positive electrode comprises (ii) antimony, lead, tin, tellurium, bismuth, or any combination thereof.

33. The energy storage device of claim 19, wherein the energy storage device is transportable at the operating temperature.

* * * * *