



(19) **United States**

(12) **Patent Application Publication**
Burbank et al.

(10) **Pub. No.: US 2013/0012914 A1**

(43) **Pub. Date: Jan. 10, 2013**

(54) **WASTE BALANCING FOR EXTRACORPOREAL BLOOD TREATMENT SYSTEMS**

(60) Provisional application No. 60/440,176, filed on Jan. 15, 2003.

Publication Classification

(75) Inventors: **Jeffrey H. Burbank**, Boxford, MA (US); **James M. Brugger**, Newburyport, MA (US)

(51) **Int. Cl.**
A61M 1/14 (2006.01)

(73) Assignee: **NXSTAGE MEDICAL, INC.**, Lawrence, MA (US)

(52) **U.S. Cl.** **604/500; 604/131**

(57) **ABSTRACT**

(21) Appl. No.: **13/545,022**

One or more waste balancing systems may be used in a fluid circulating system for medical use. The fluid circulating system may be part of a blood treatment system for a patient suffering renal failure. A waste balancing system may include a pressure element operable to maintain a constant fluid pressure created by the combined weight of waste removed from a patient and replacement fluid for providing to a patient. Multiple evaluation characteristics or control parameters may be evaluated or controlled for safety and accuracy. At least part of the waste balancing system may be incorporated into a disposable cartridge.

(22) Filed: **Jul. 10, 2012**

Related U.S. Application Data

(63) Continuation of application No. 12/536,412, filed on Aug. 5, 2009, now Pat. No. 8,235,931, which is a continuation-in-part of application No. 10/544,124, filed on Aug. 7, 2006, now Pat. No. 7,686,778, filed as application No. PCT/US04/00921 on Jan. 14, 2004.

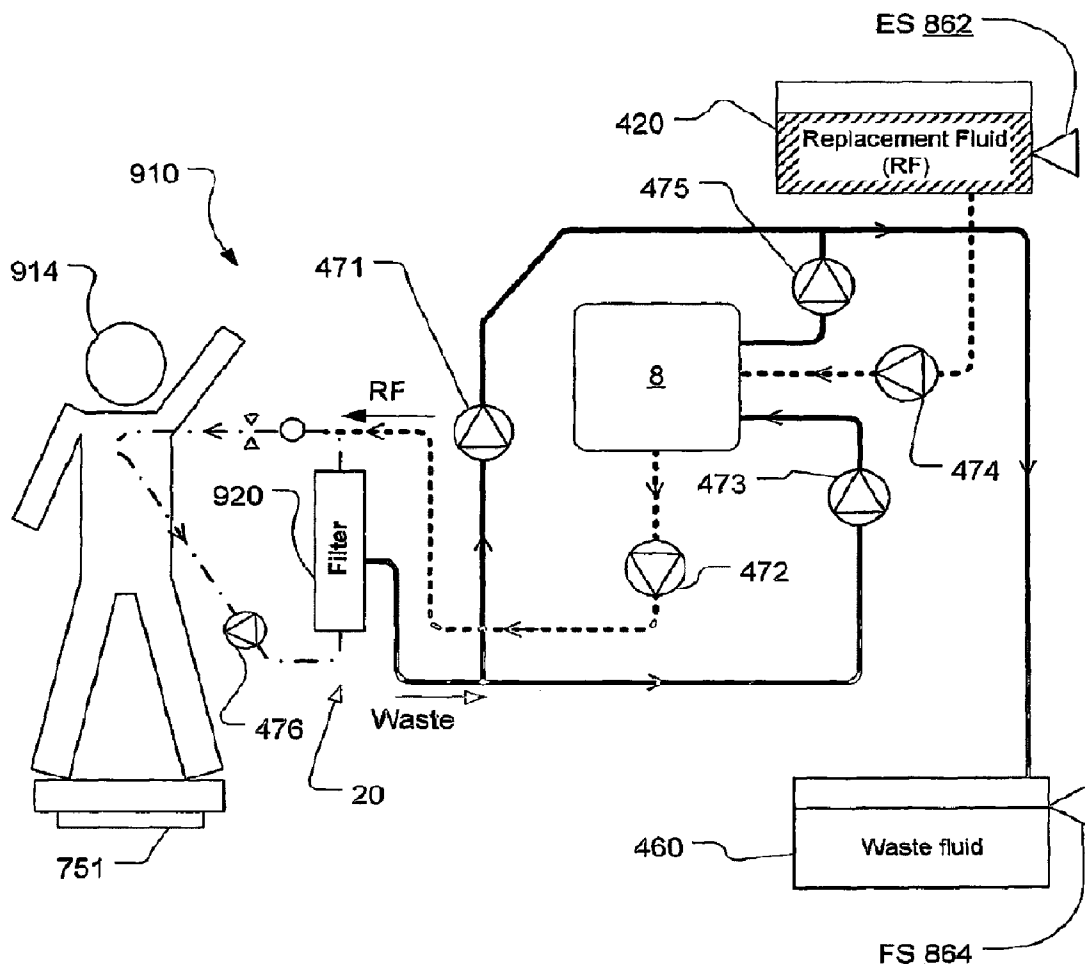

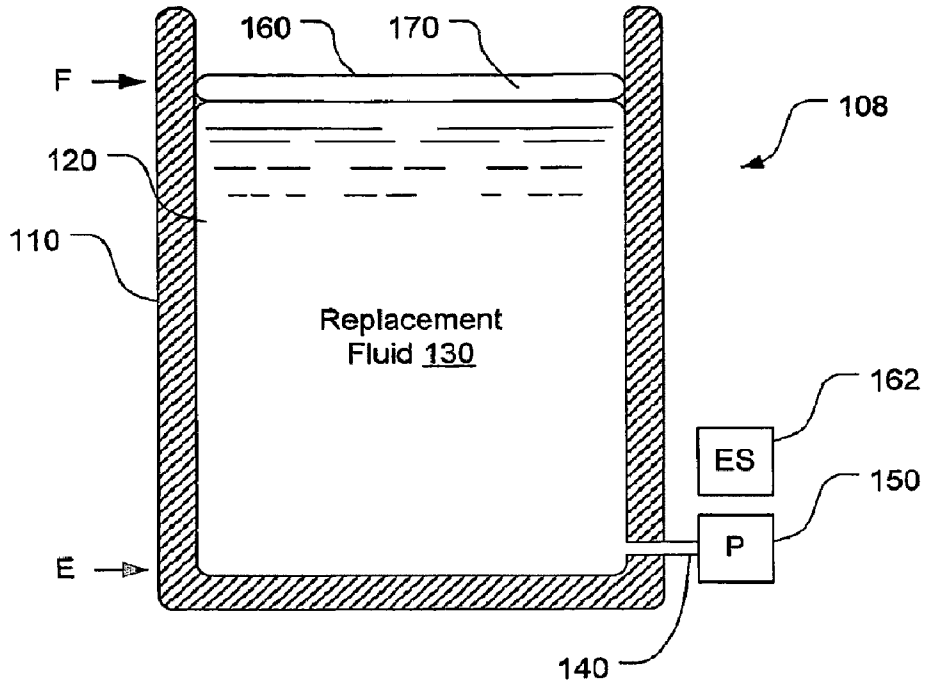

Fig. 1

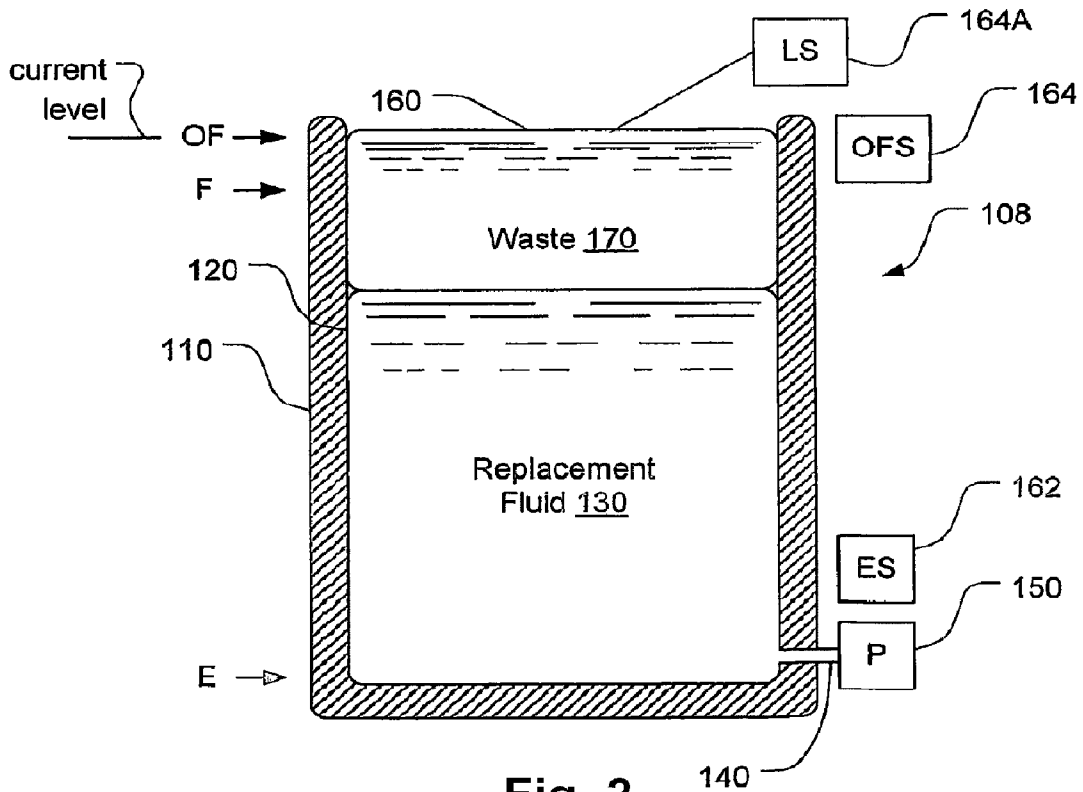

Fig. 2

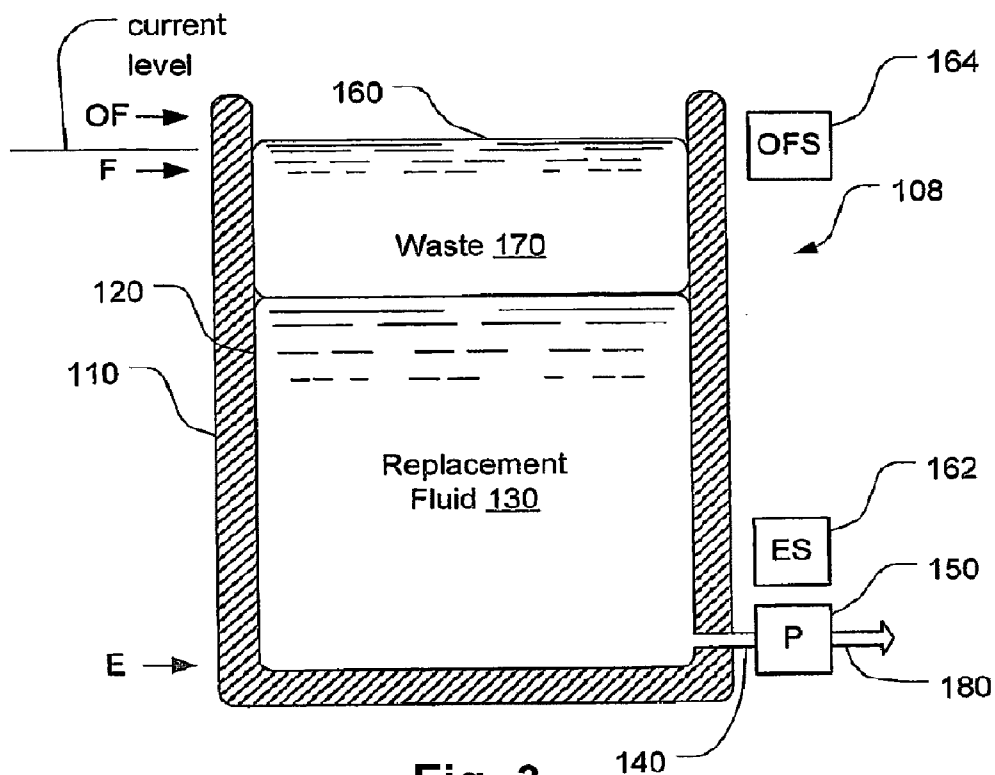

Fig. 3

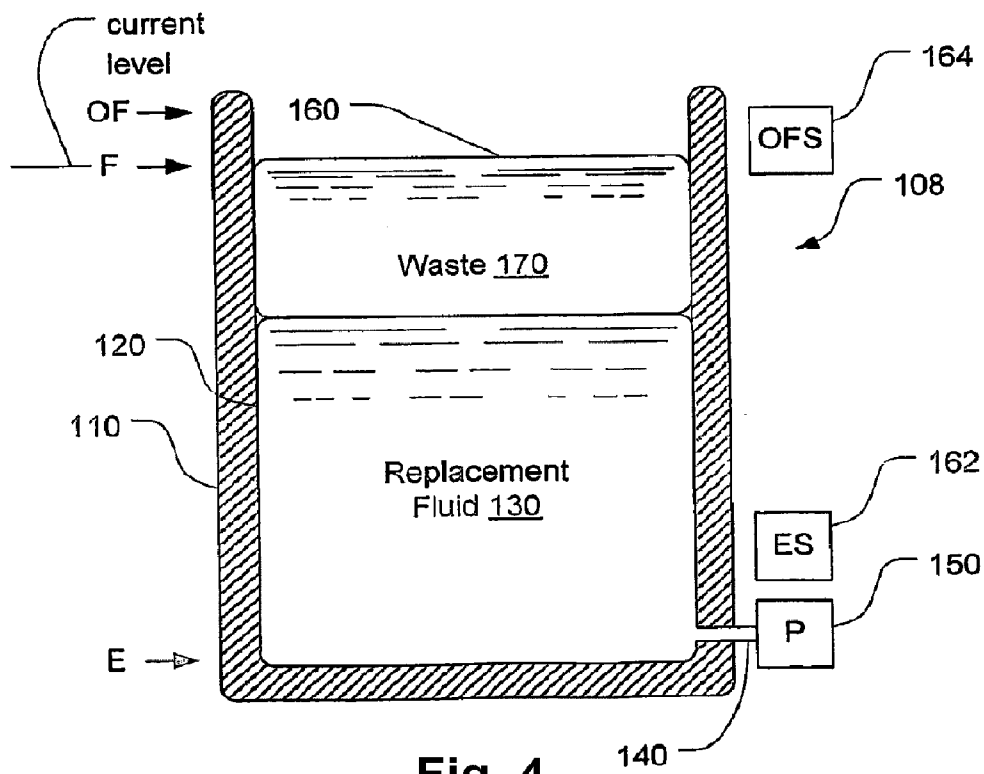

Fig. 4

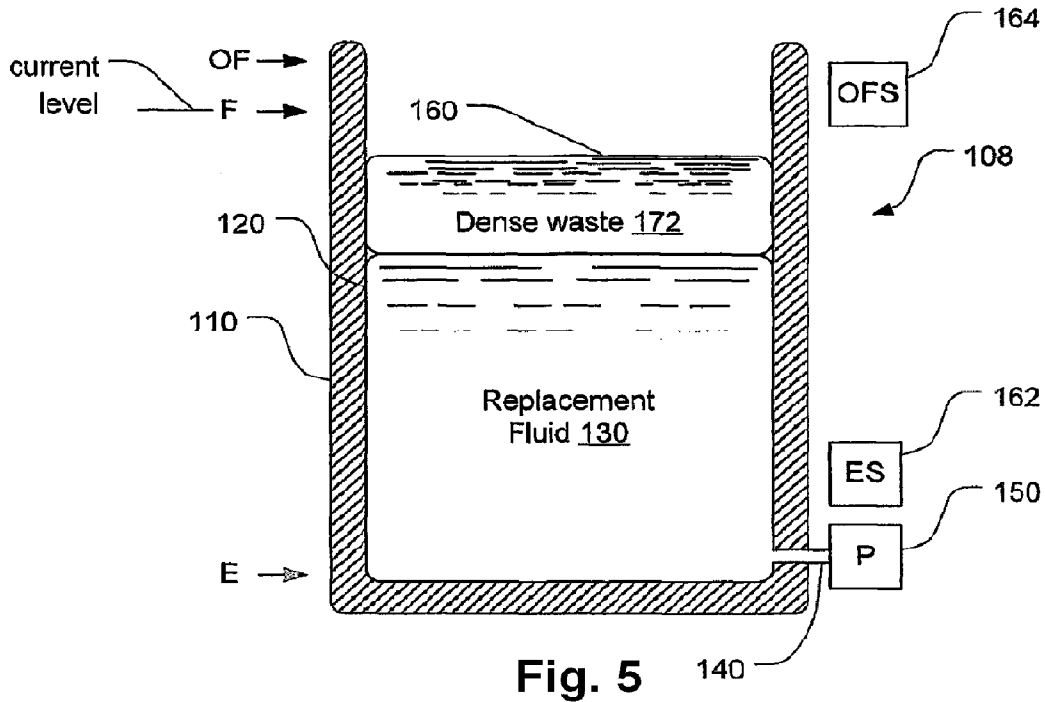

Fig. 5

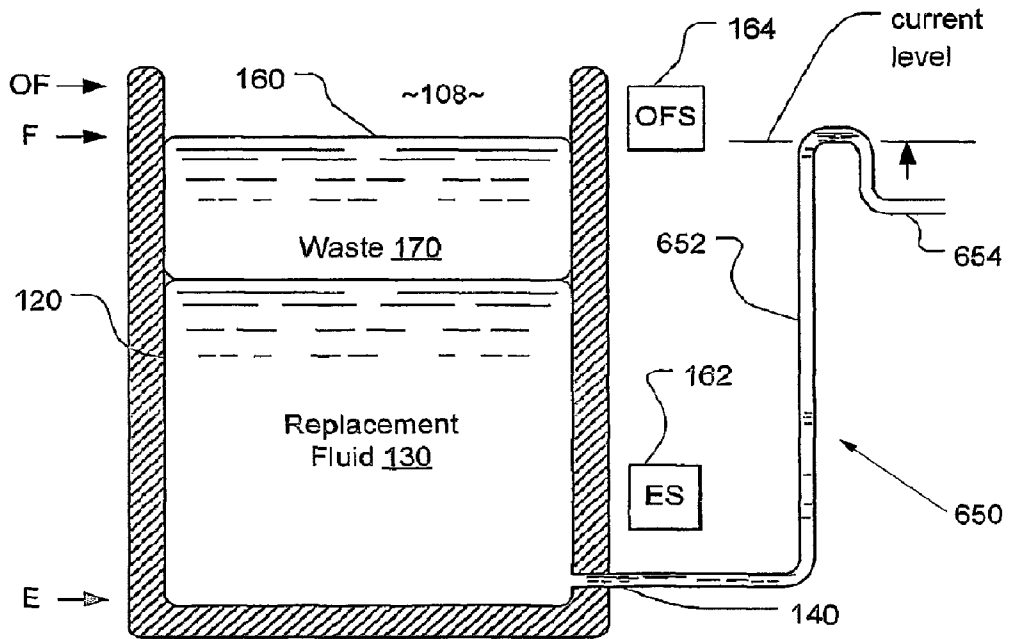

Fig. 6

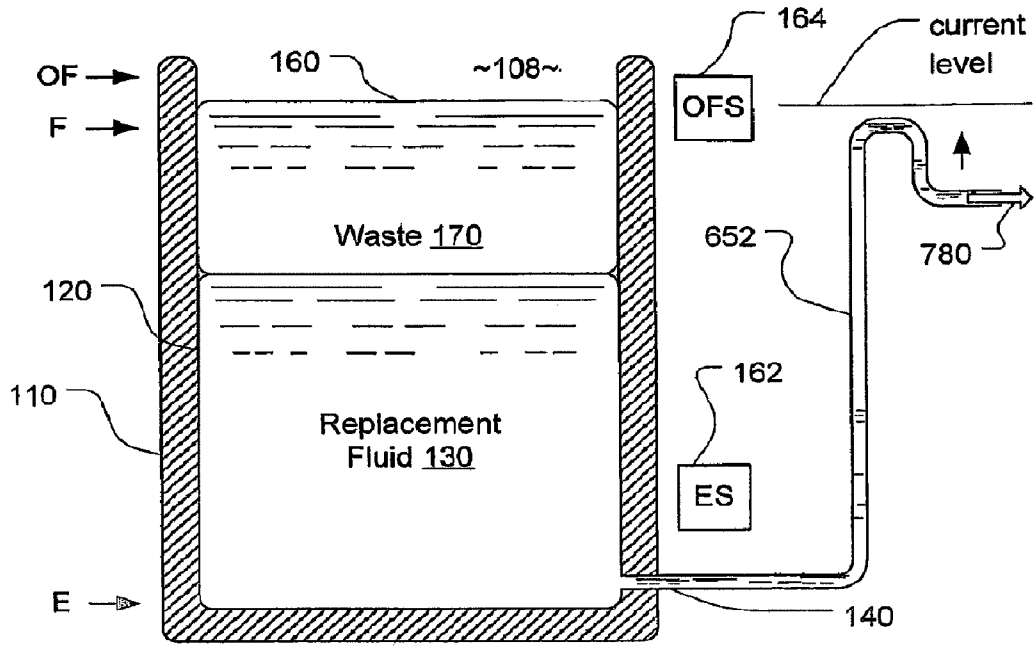

Fig. 7

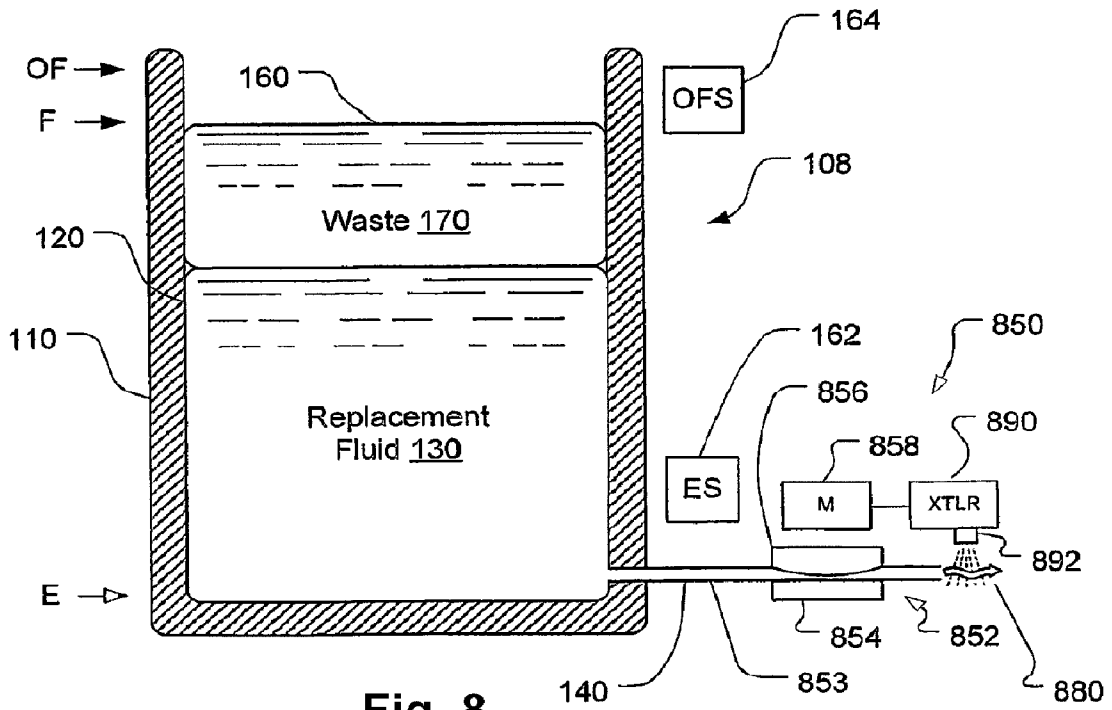

Fig. 8

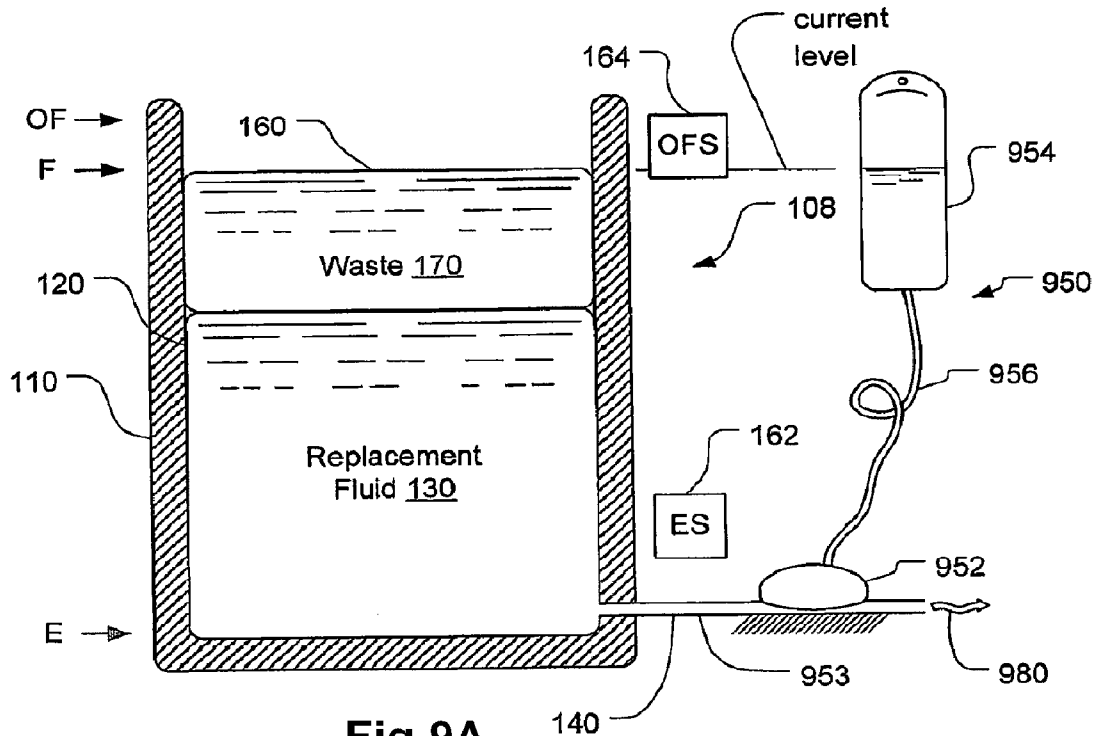

Fig 9A

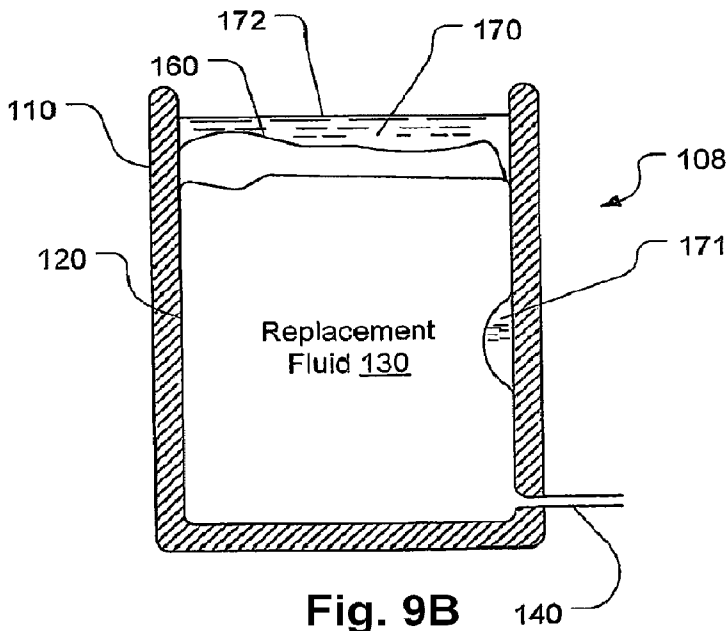

Fig. 9B

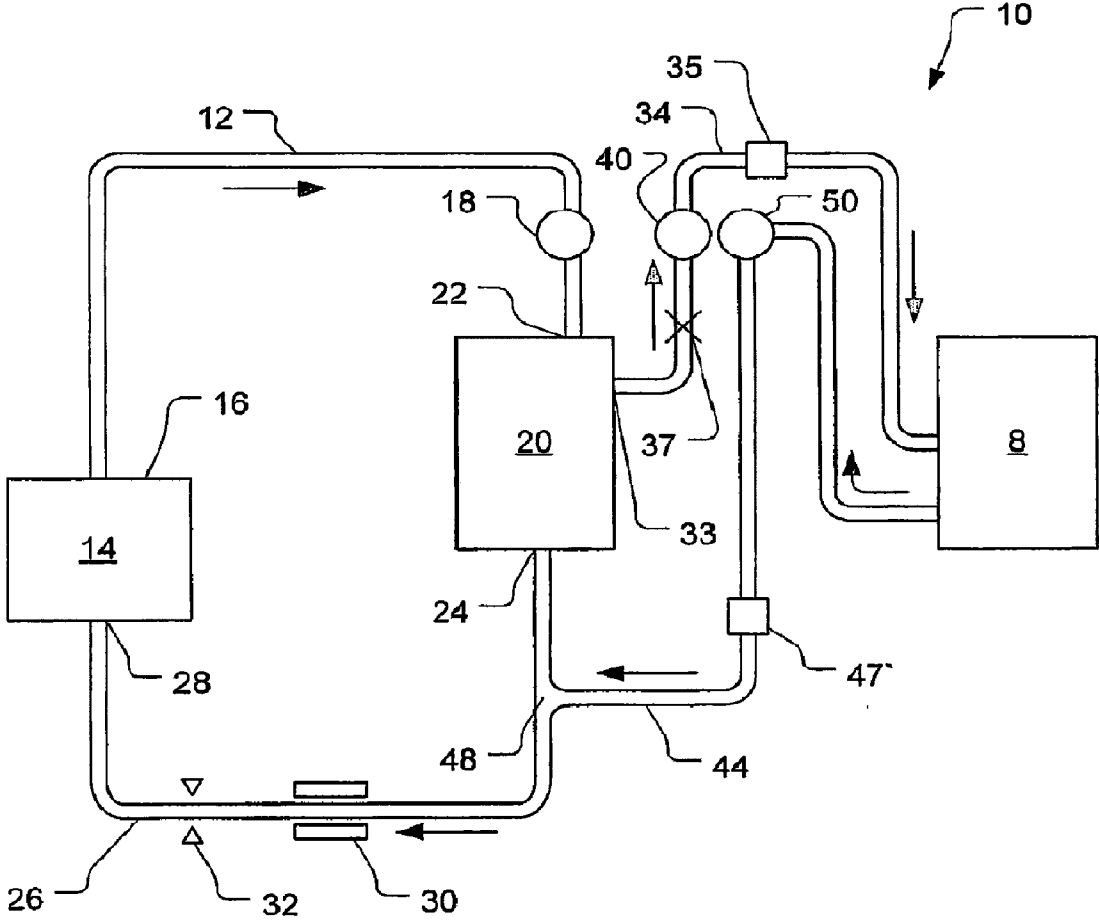

Fig. 10

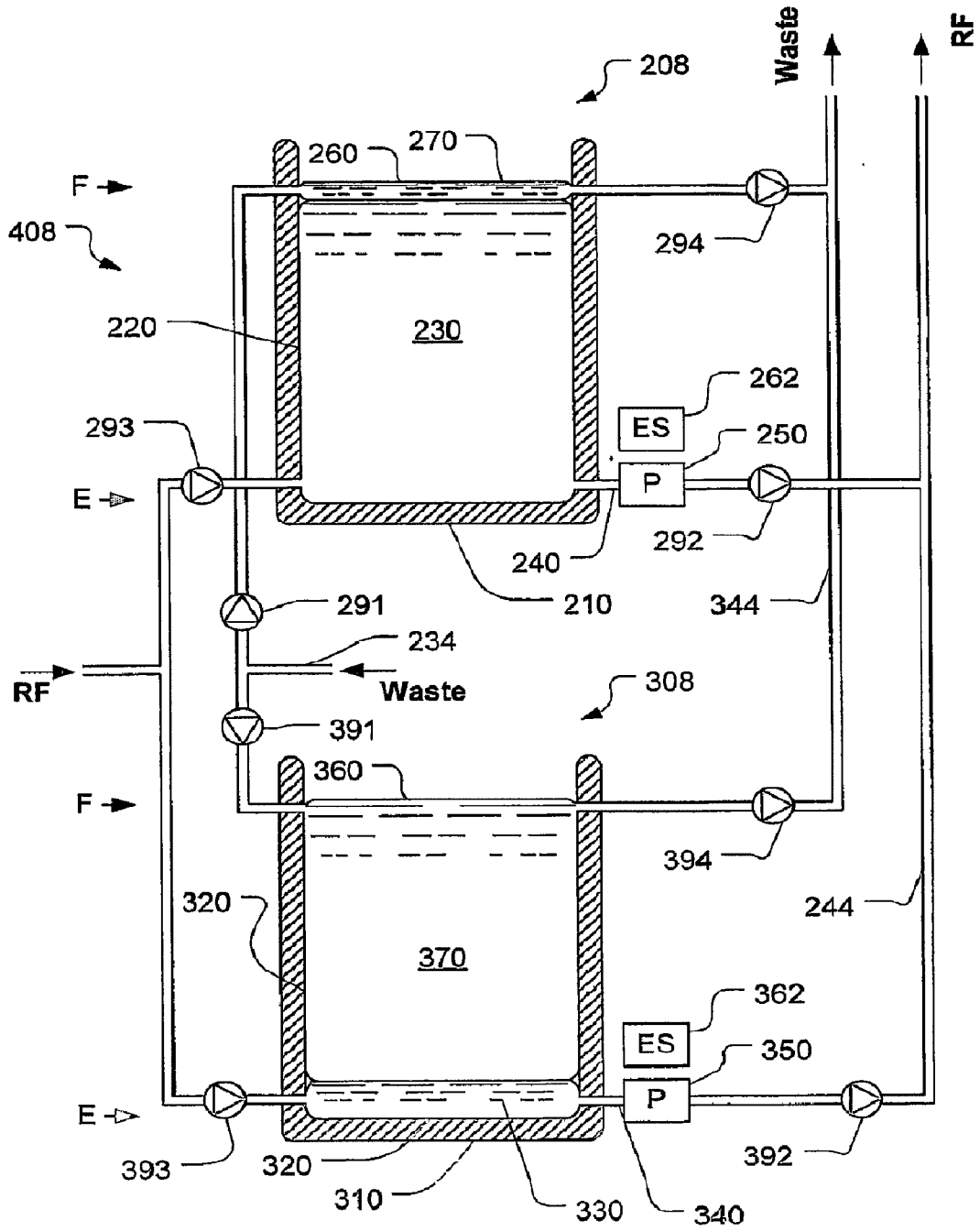
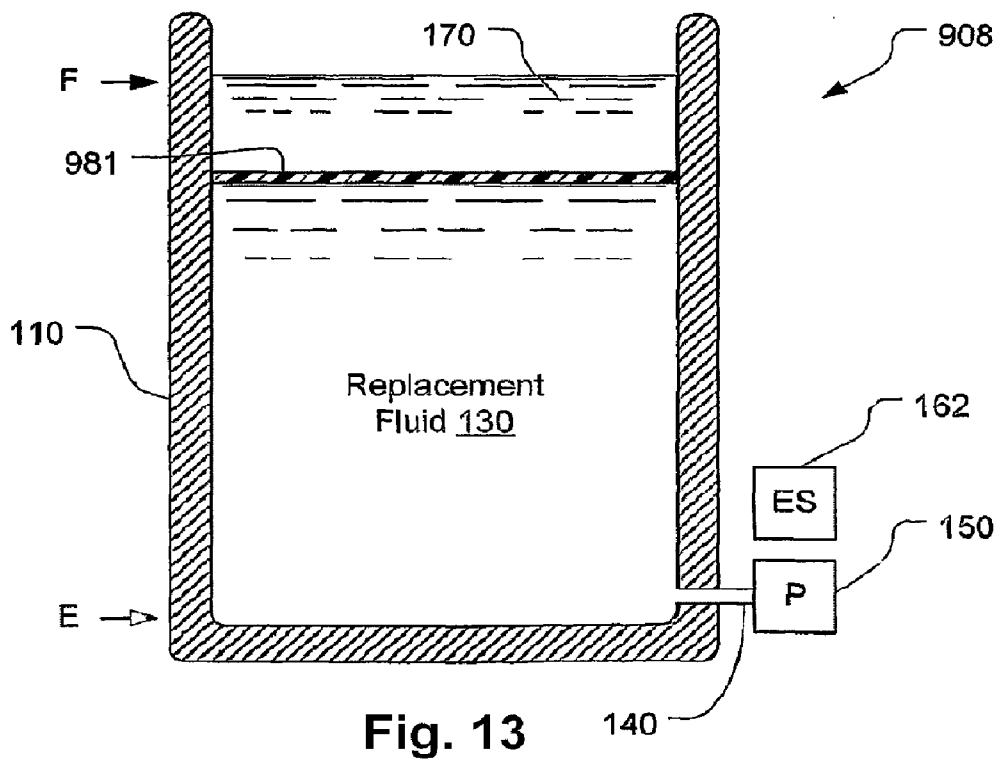
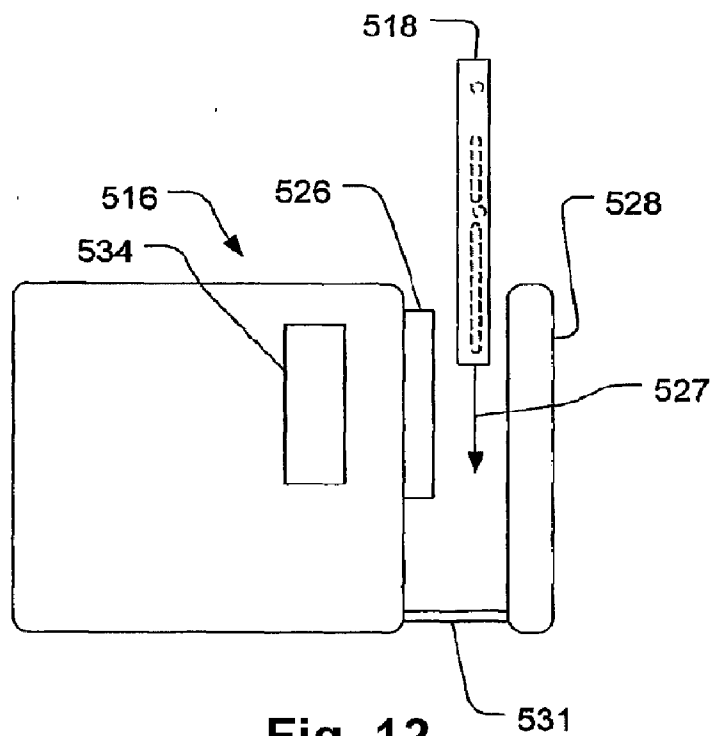

Fig. 11



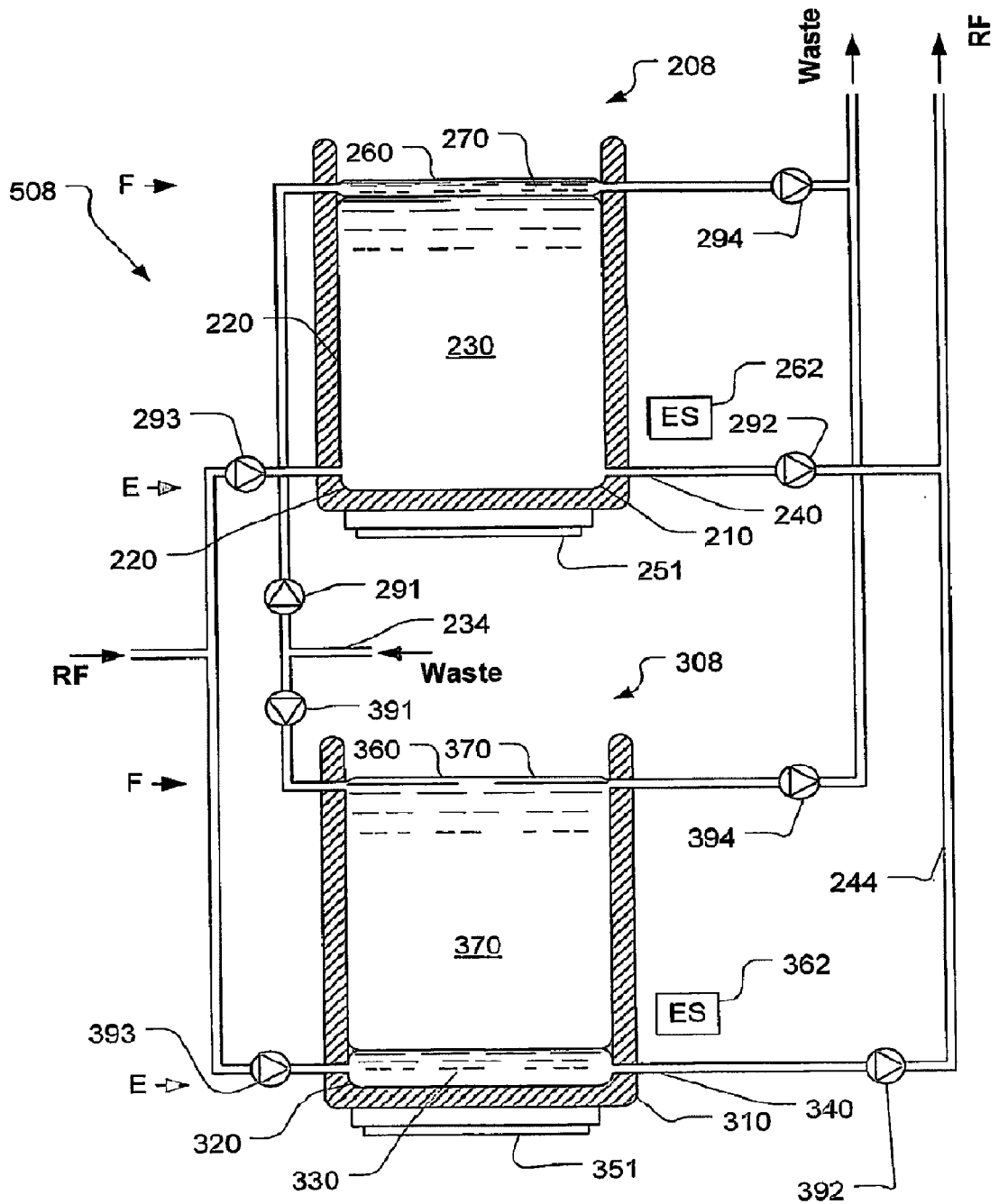

Fig. 14

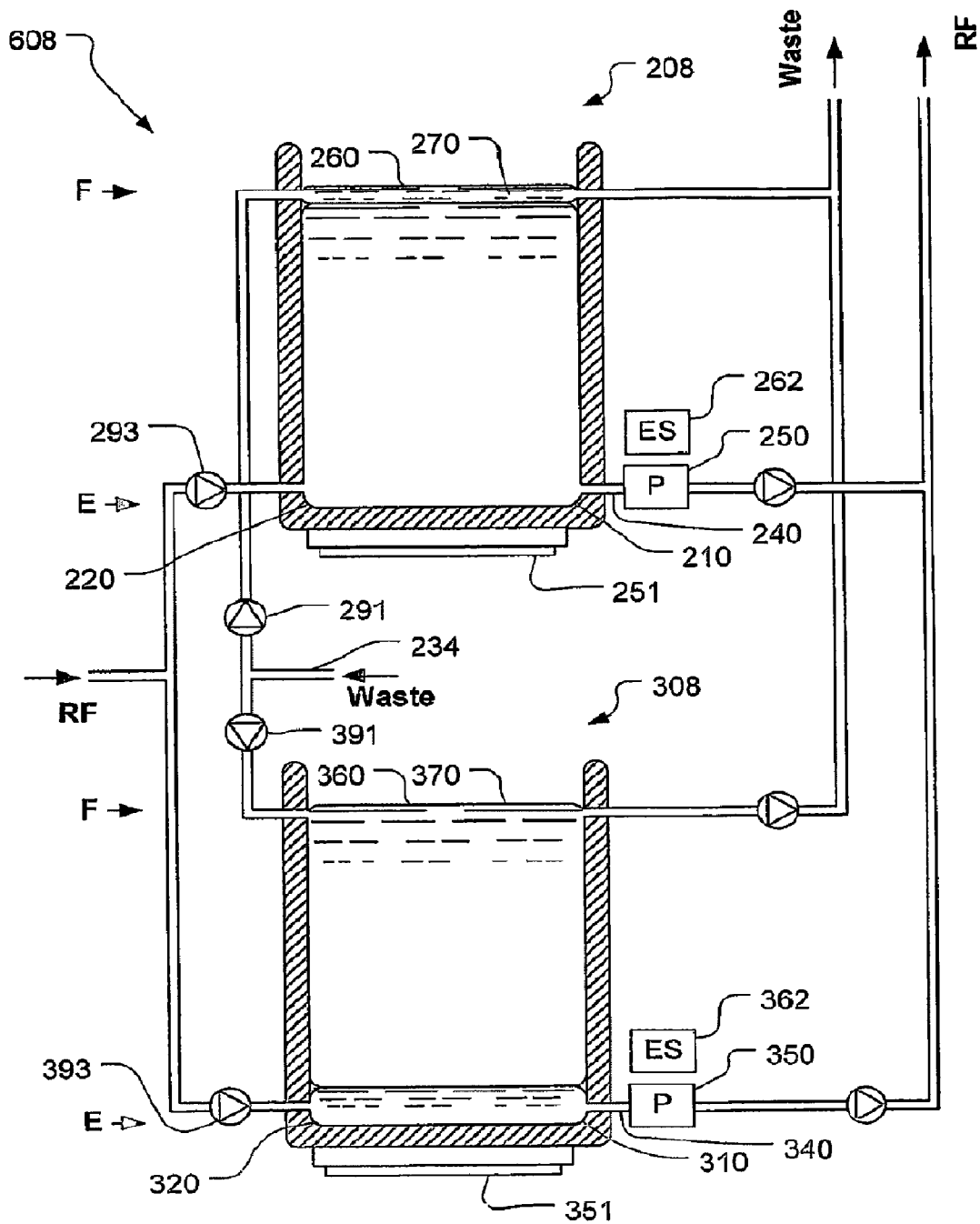

Fig. 15

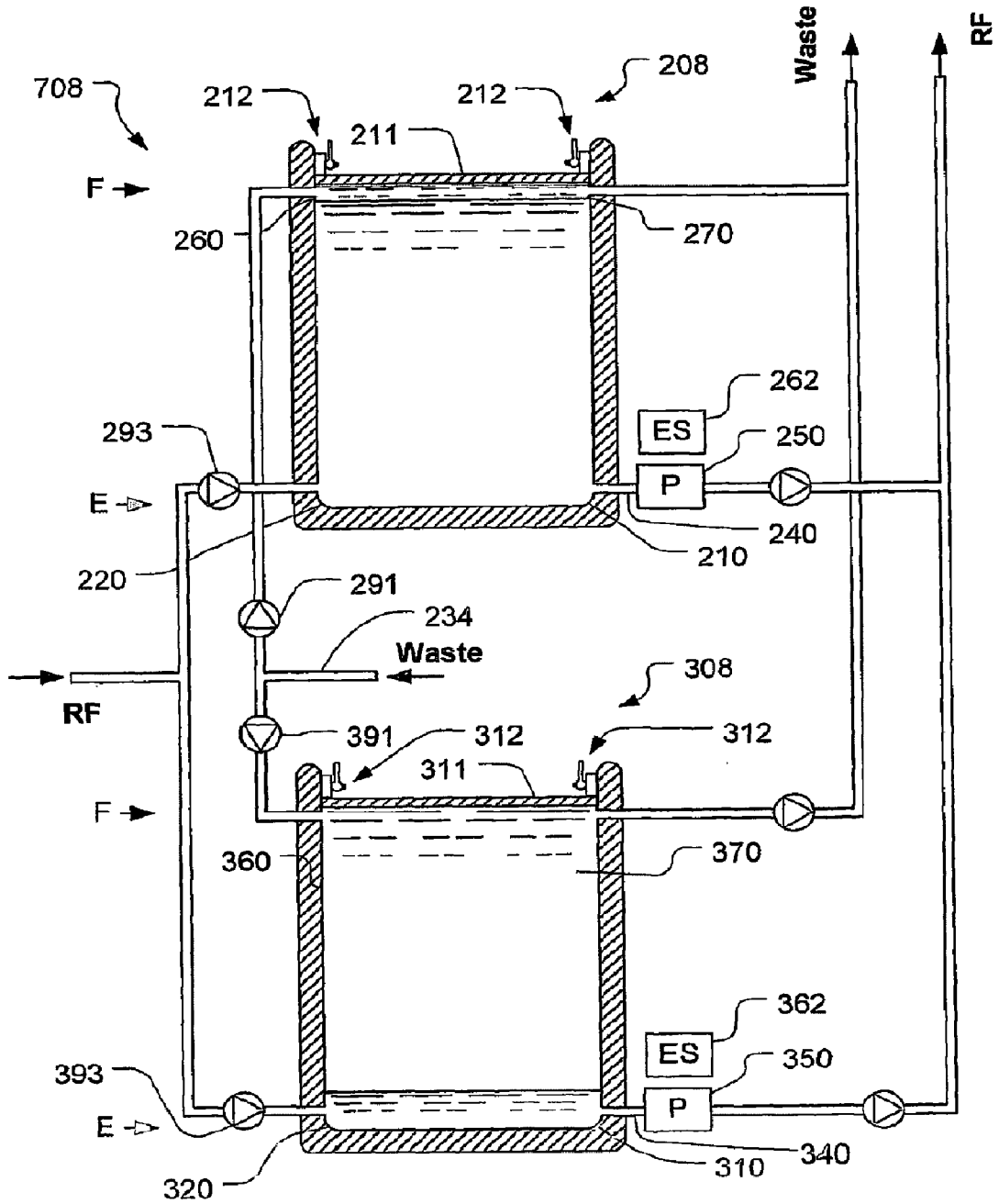

Fig. 16

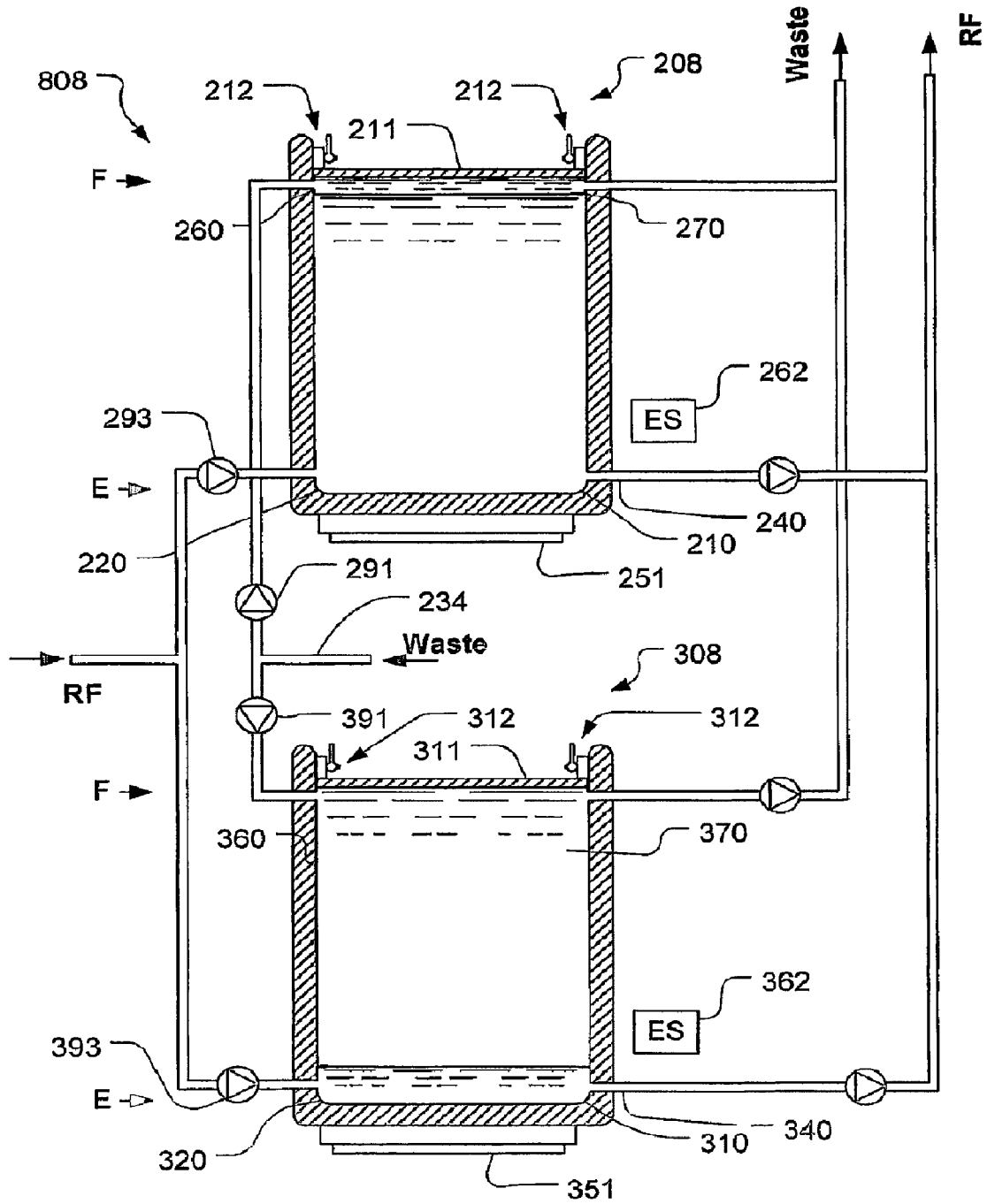

Fig. 17

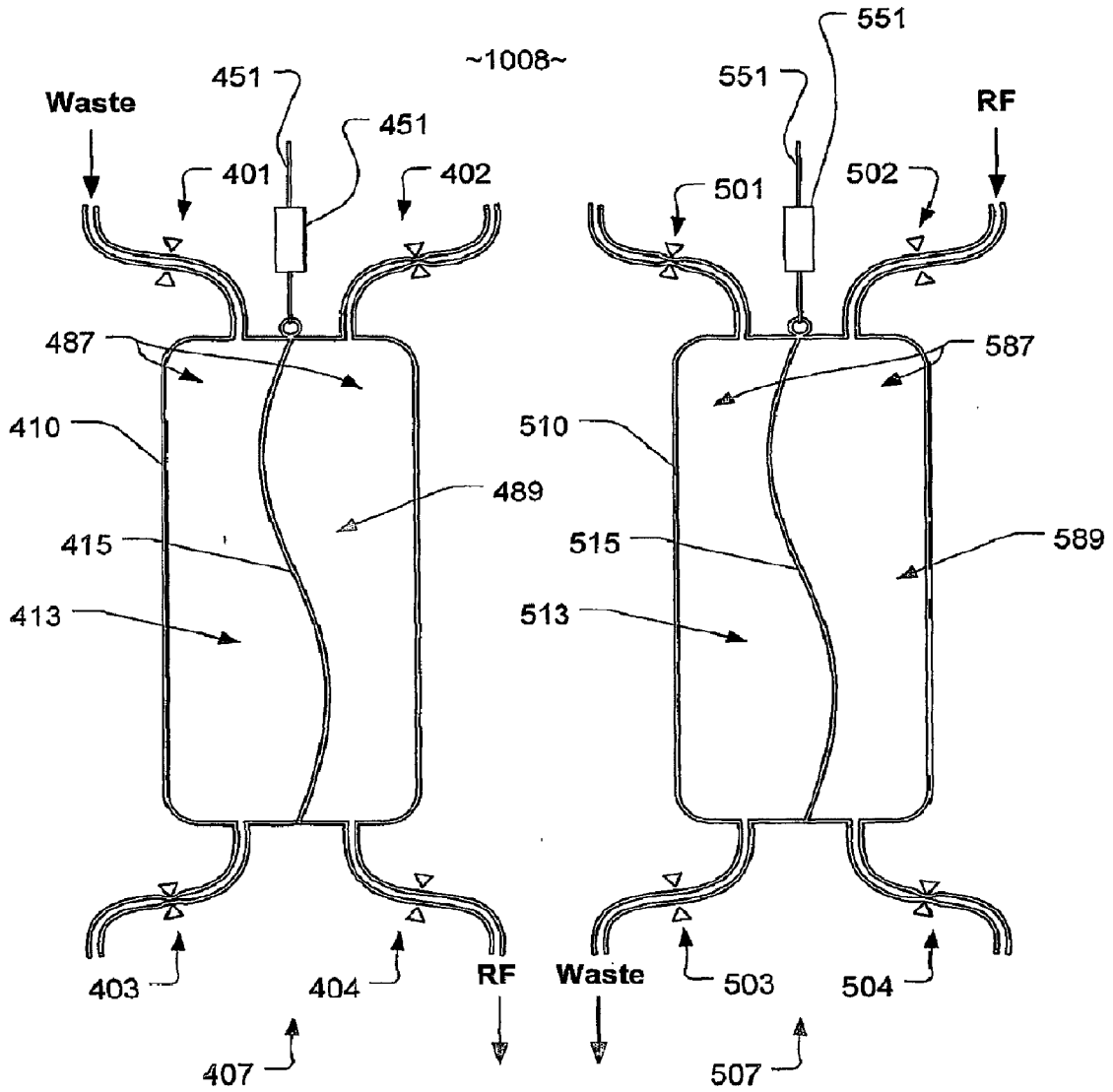

Fig. 18

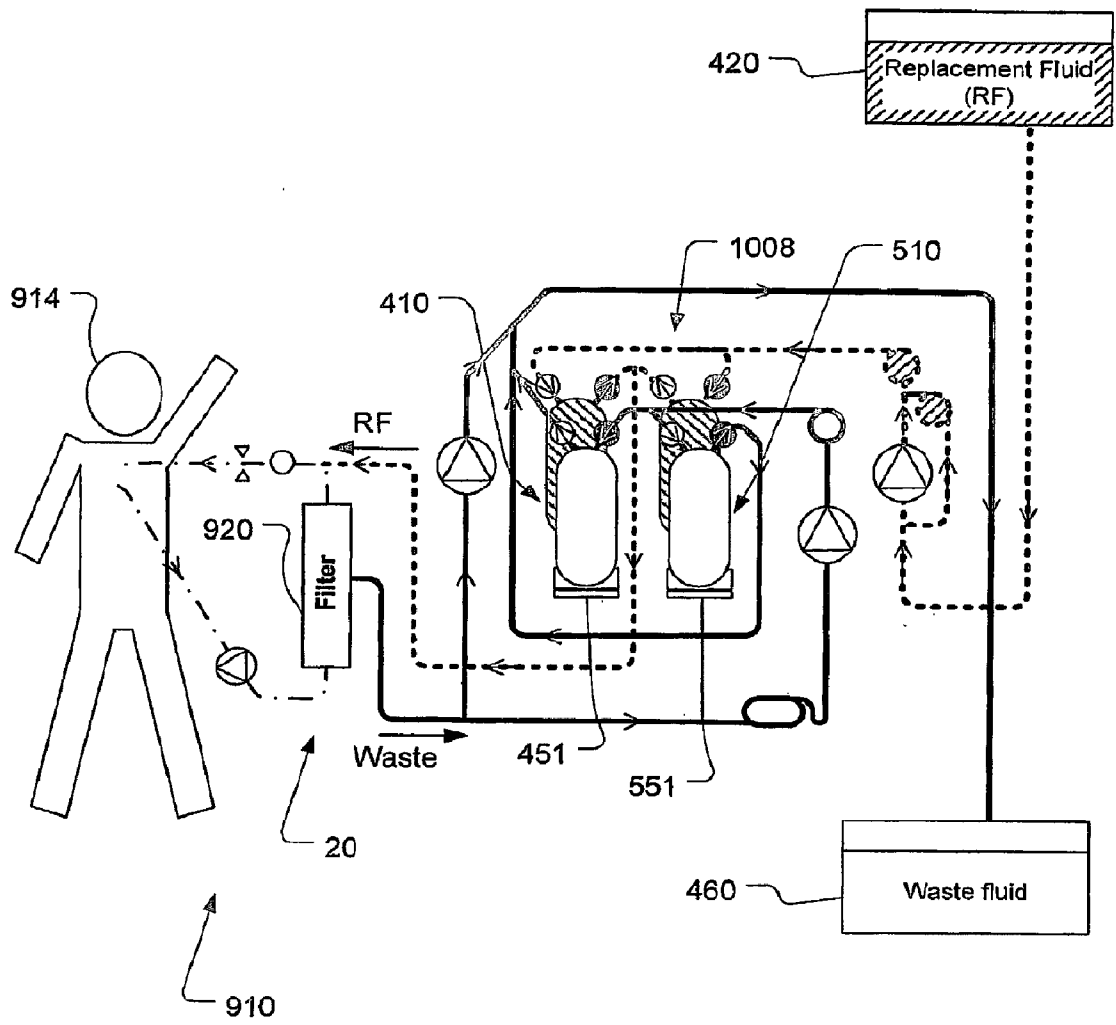

Fig. 19

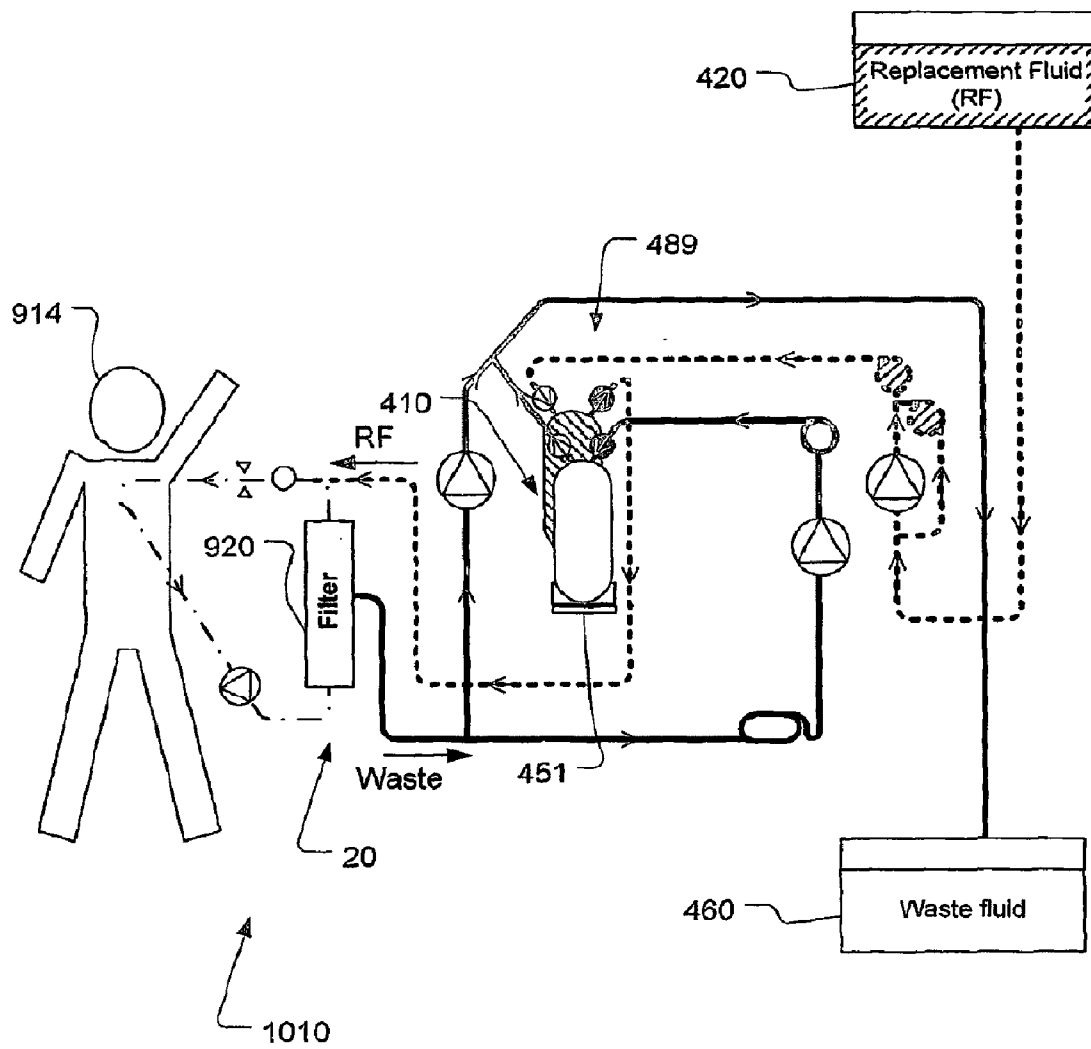

Fig. 20

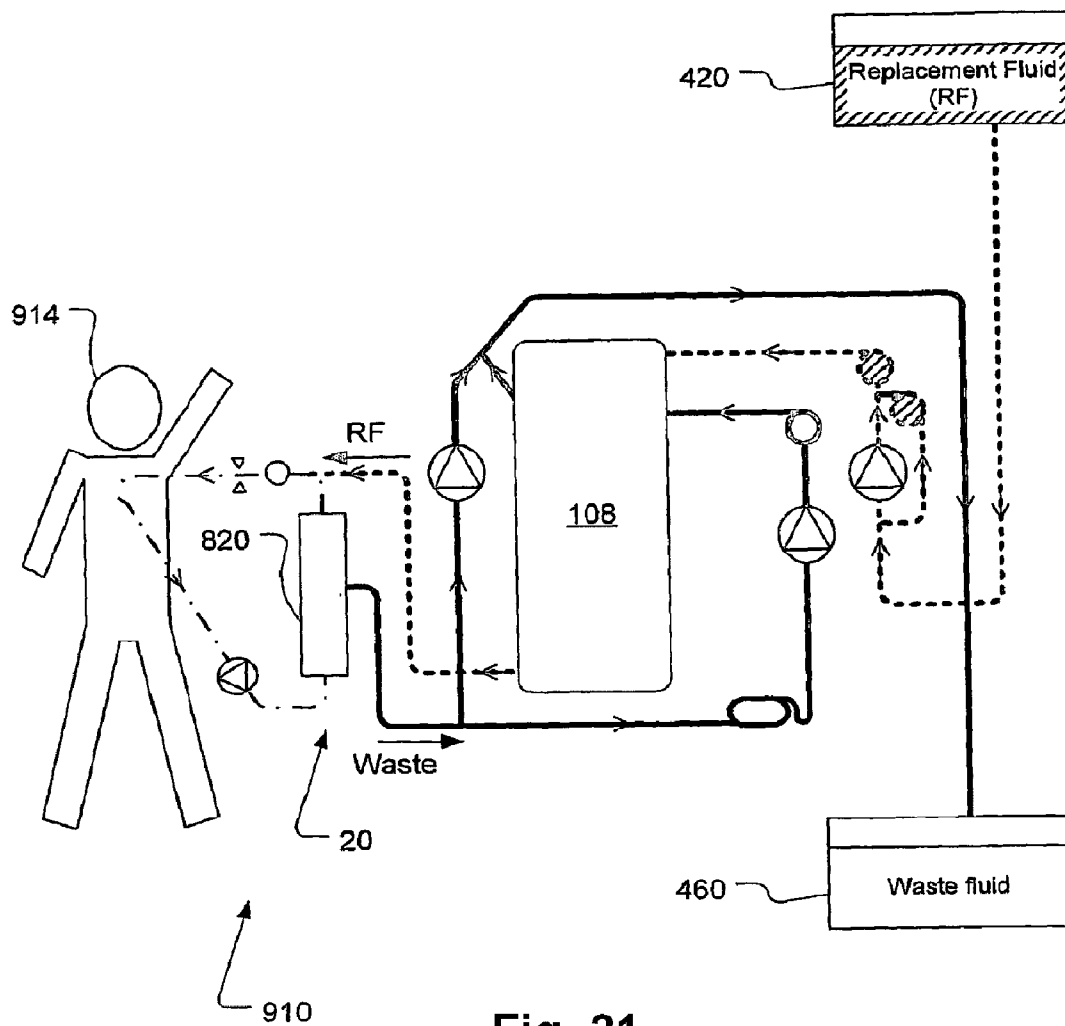

Fig. 21

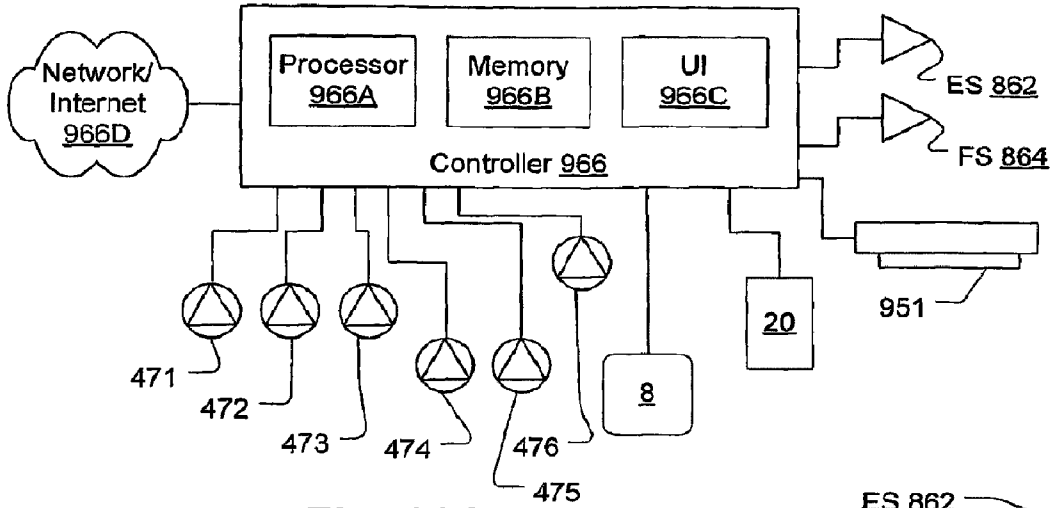

Fig. 22A

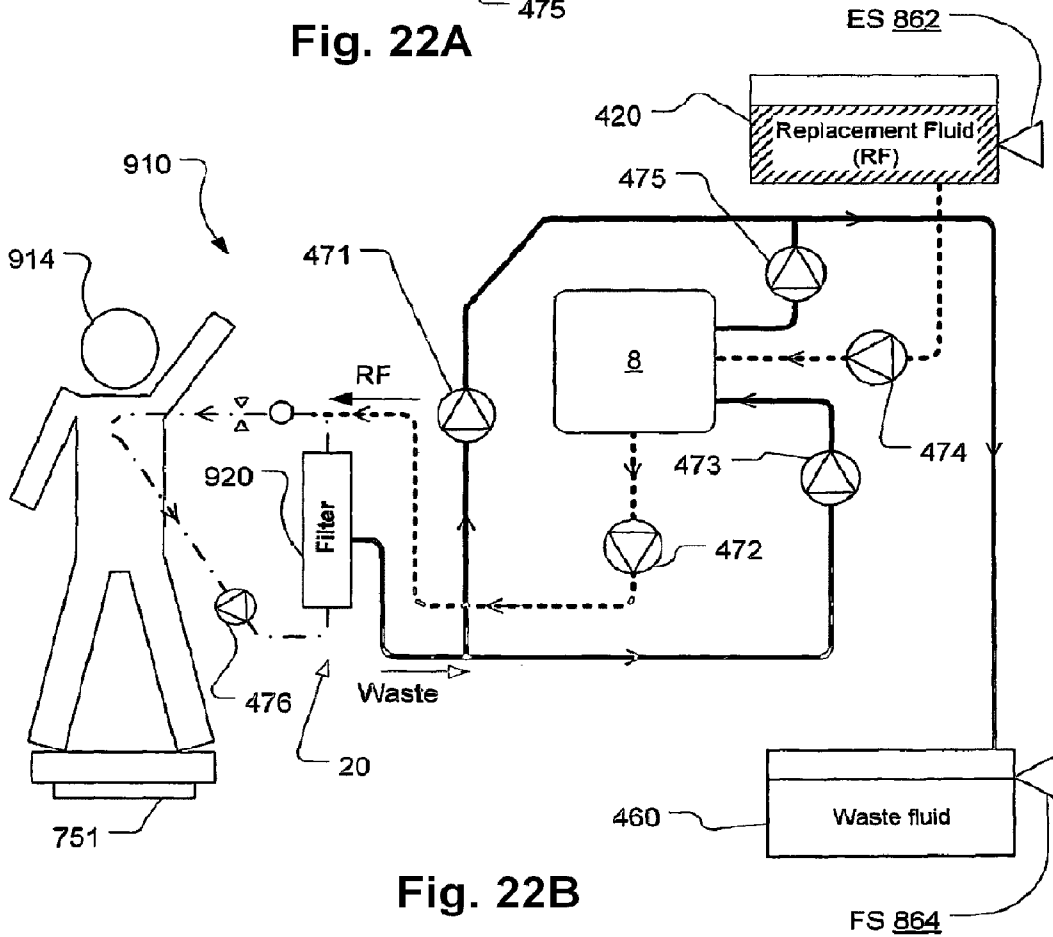

Fig. 22B

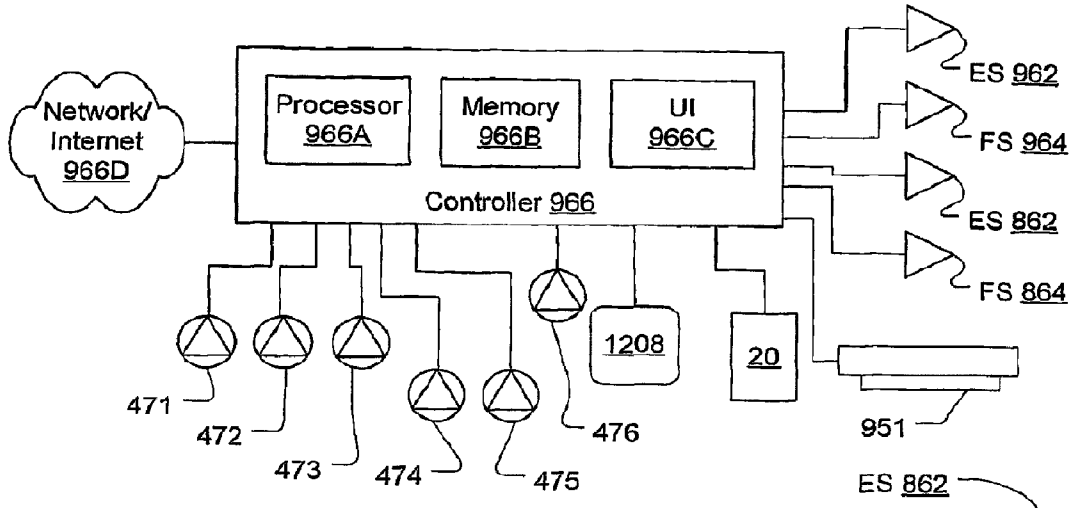

Fig. 24A

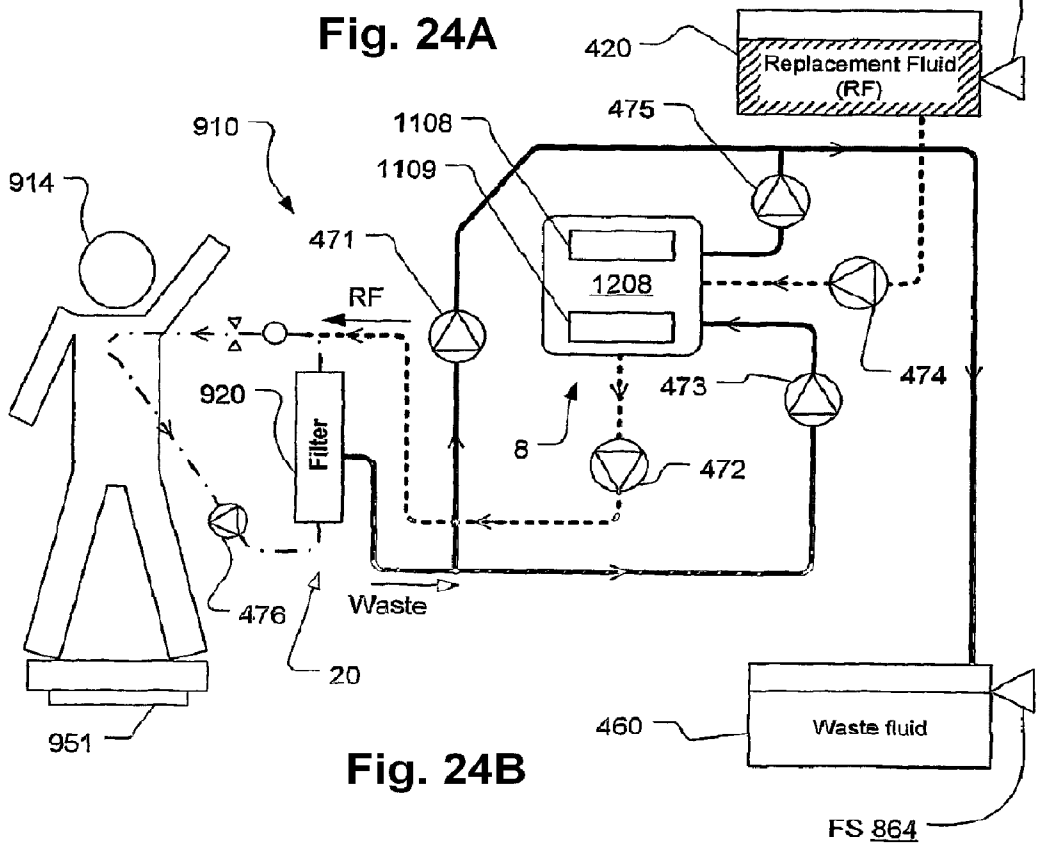

Fig. 24B

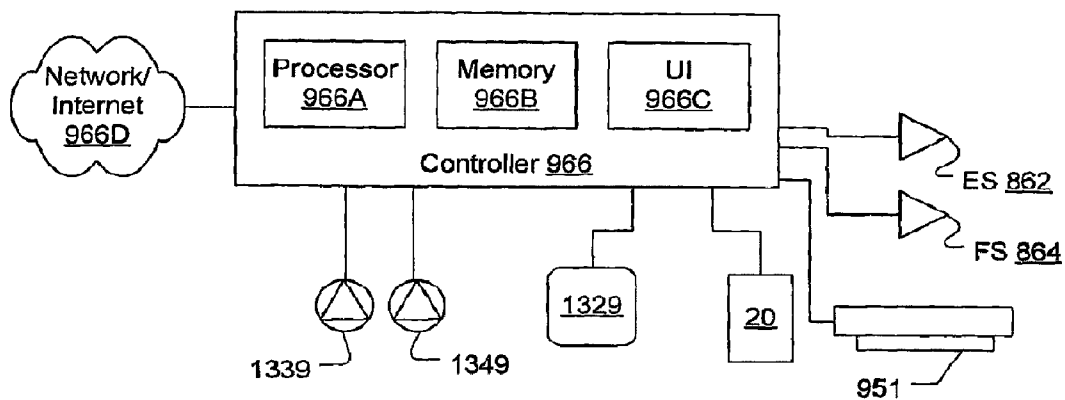

Fig. 25A

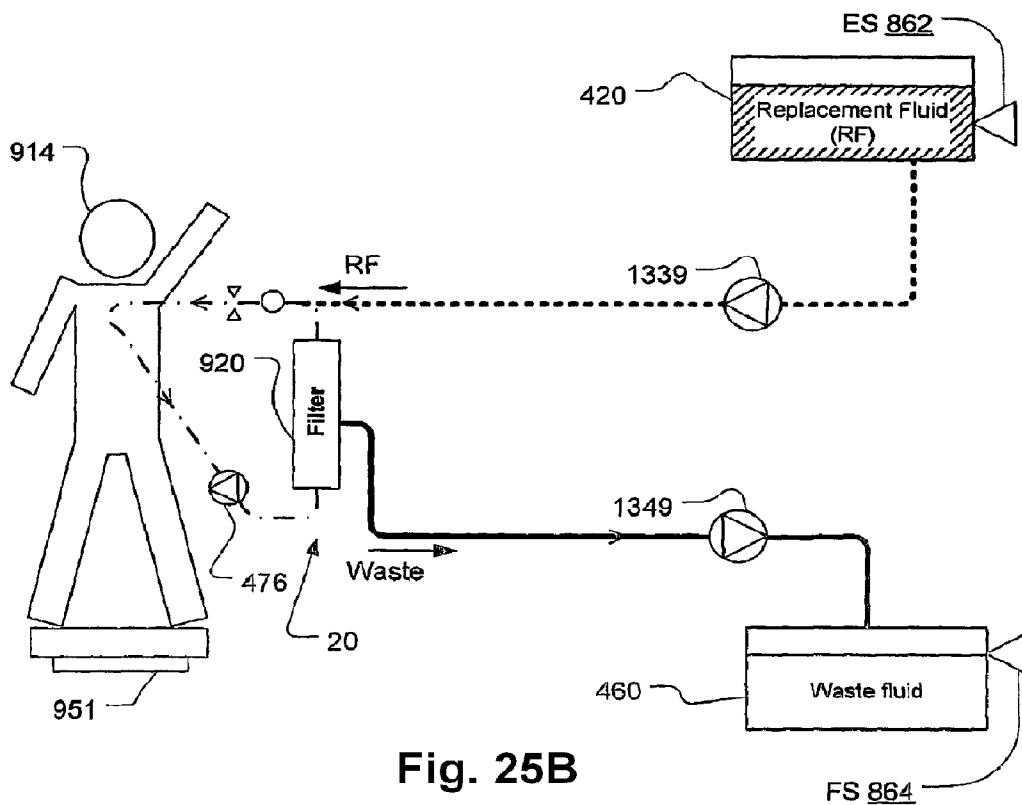

Fig. 25B

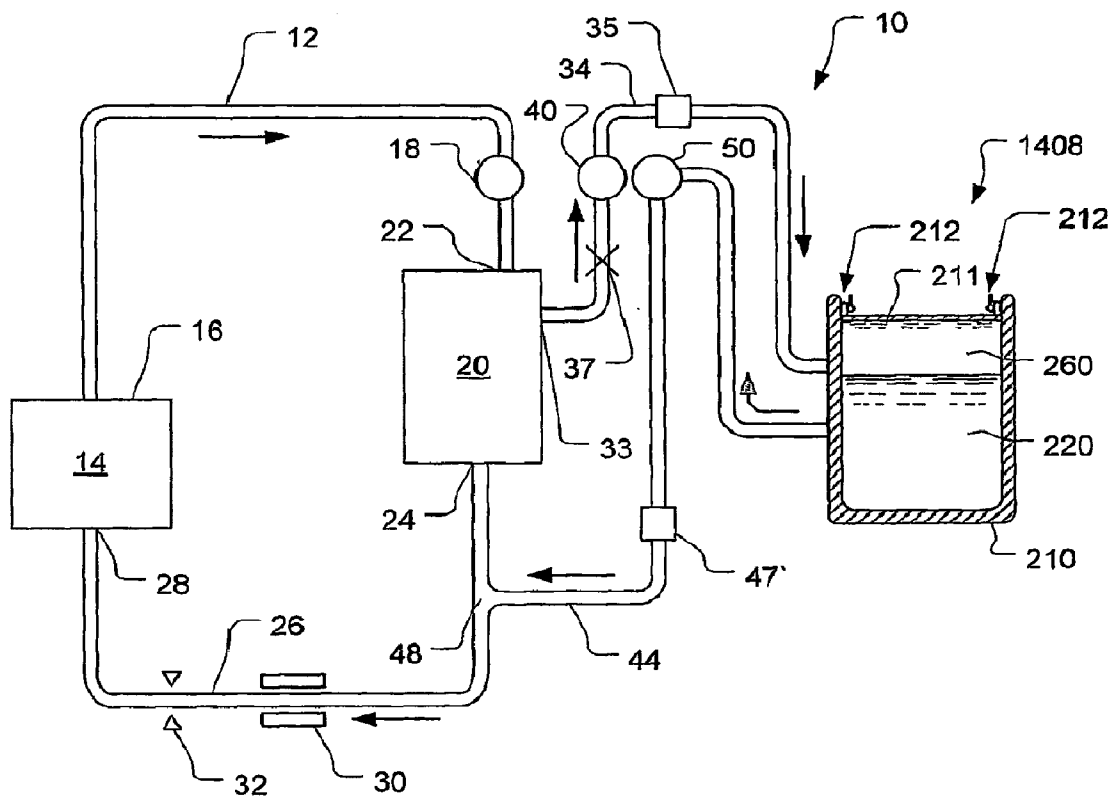

Fig. 26

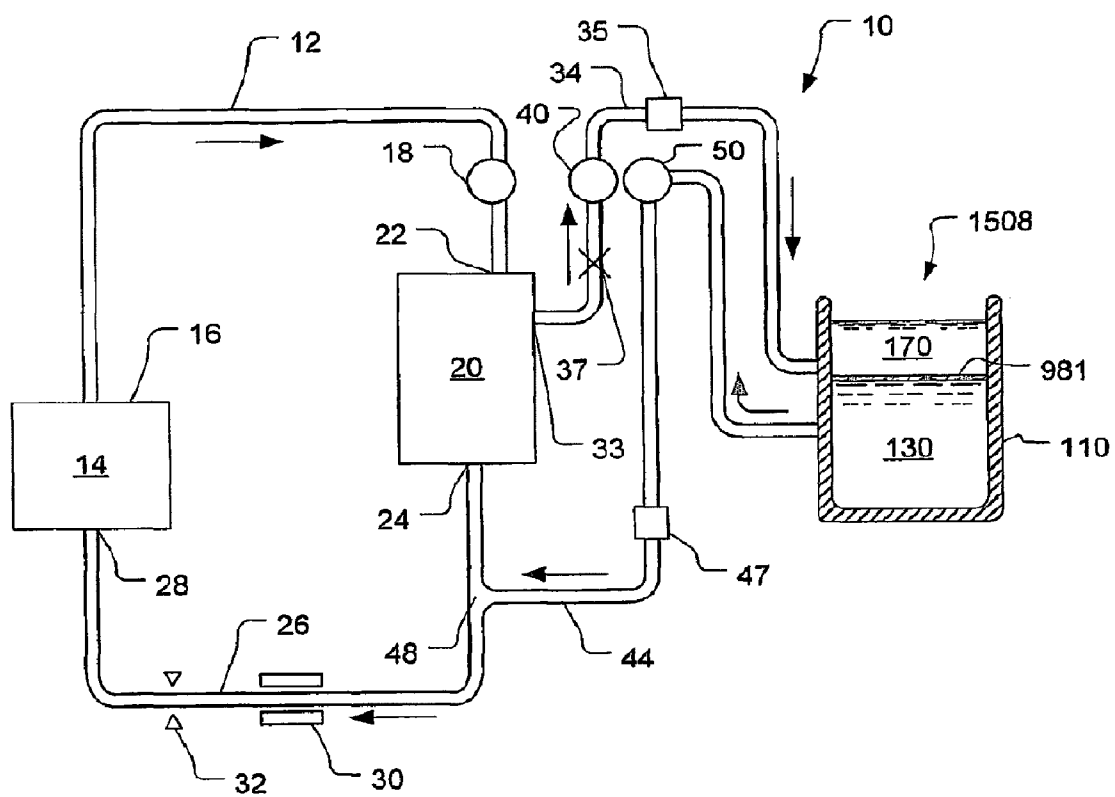
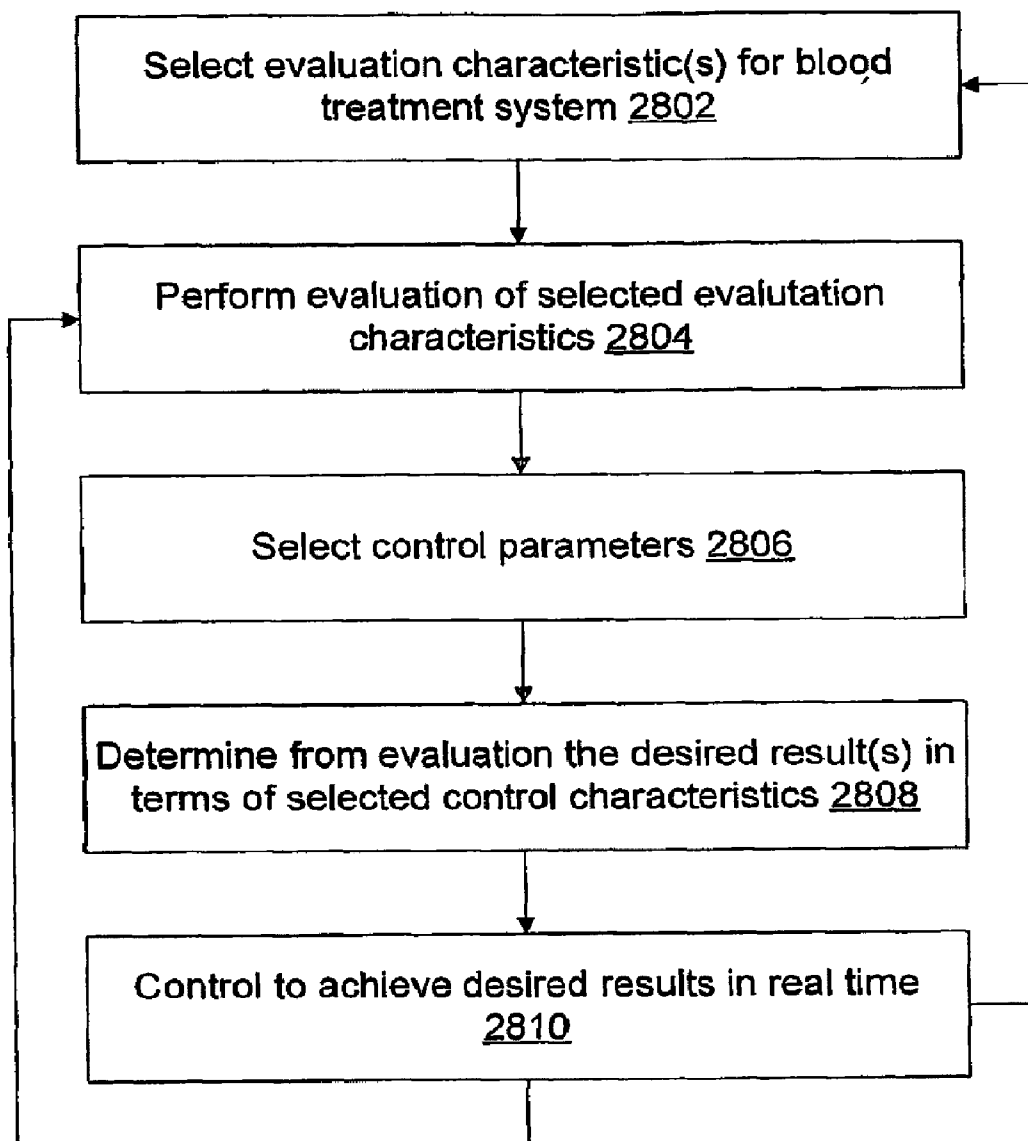

Fig. 27



~2801~

Fig. 28

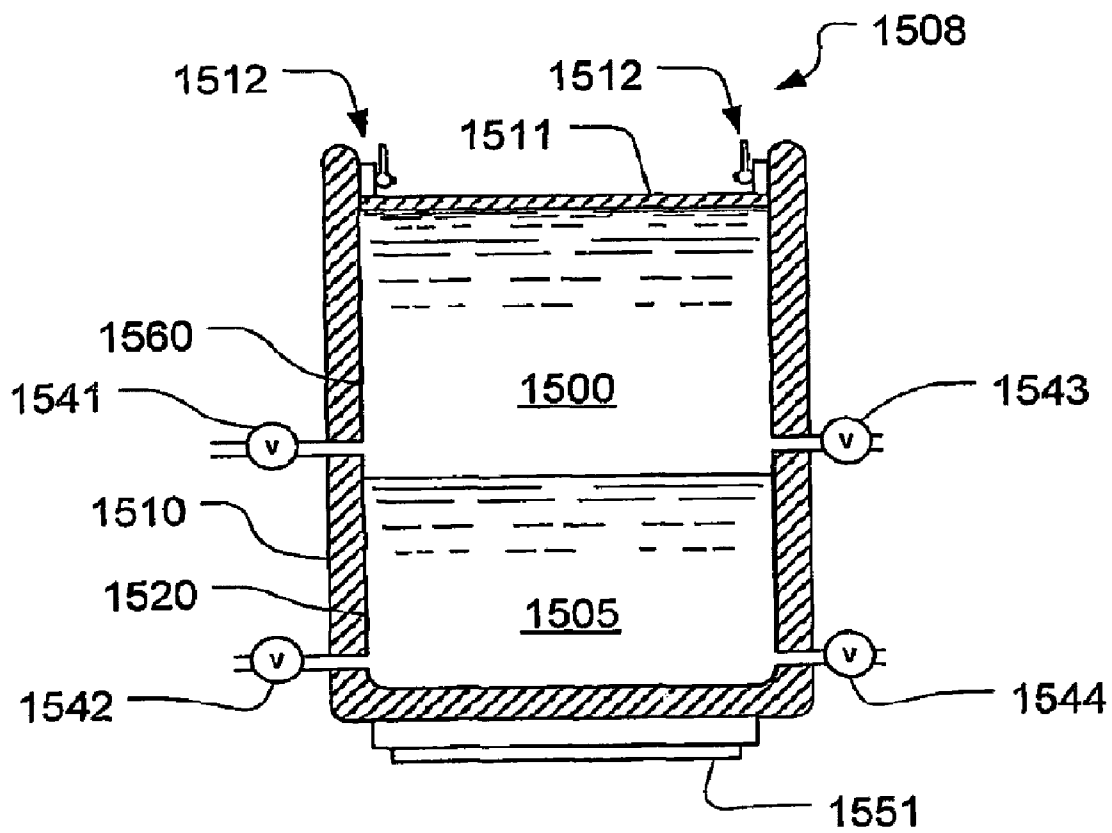

Fig. 29

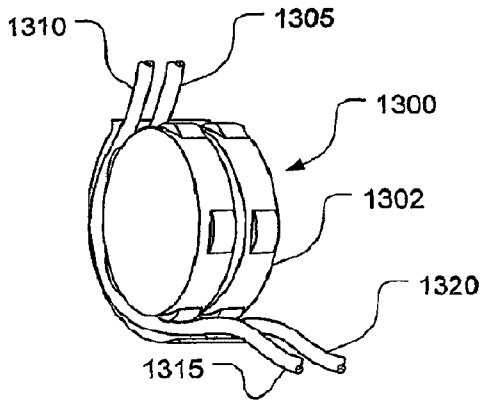

Fig. 30

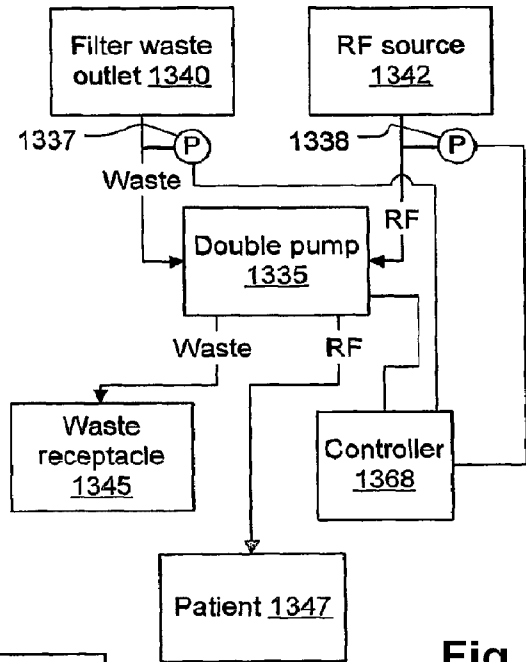

Fig. 31

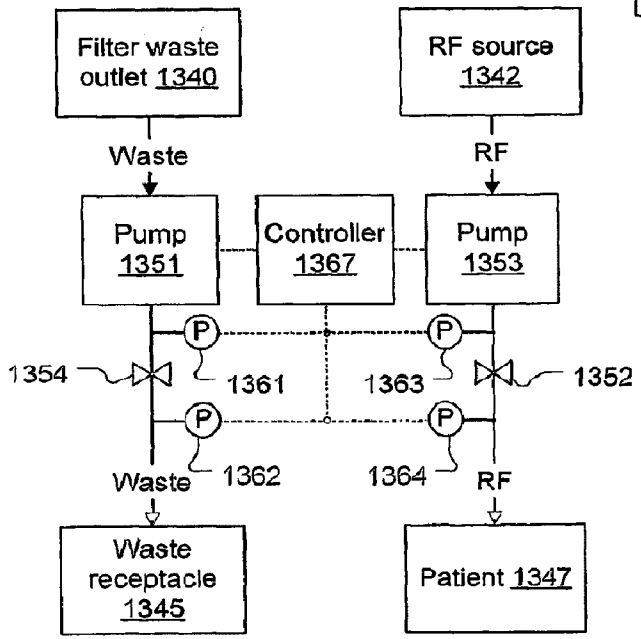

Fig. 32

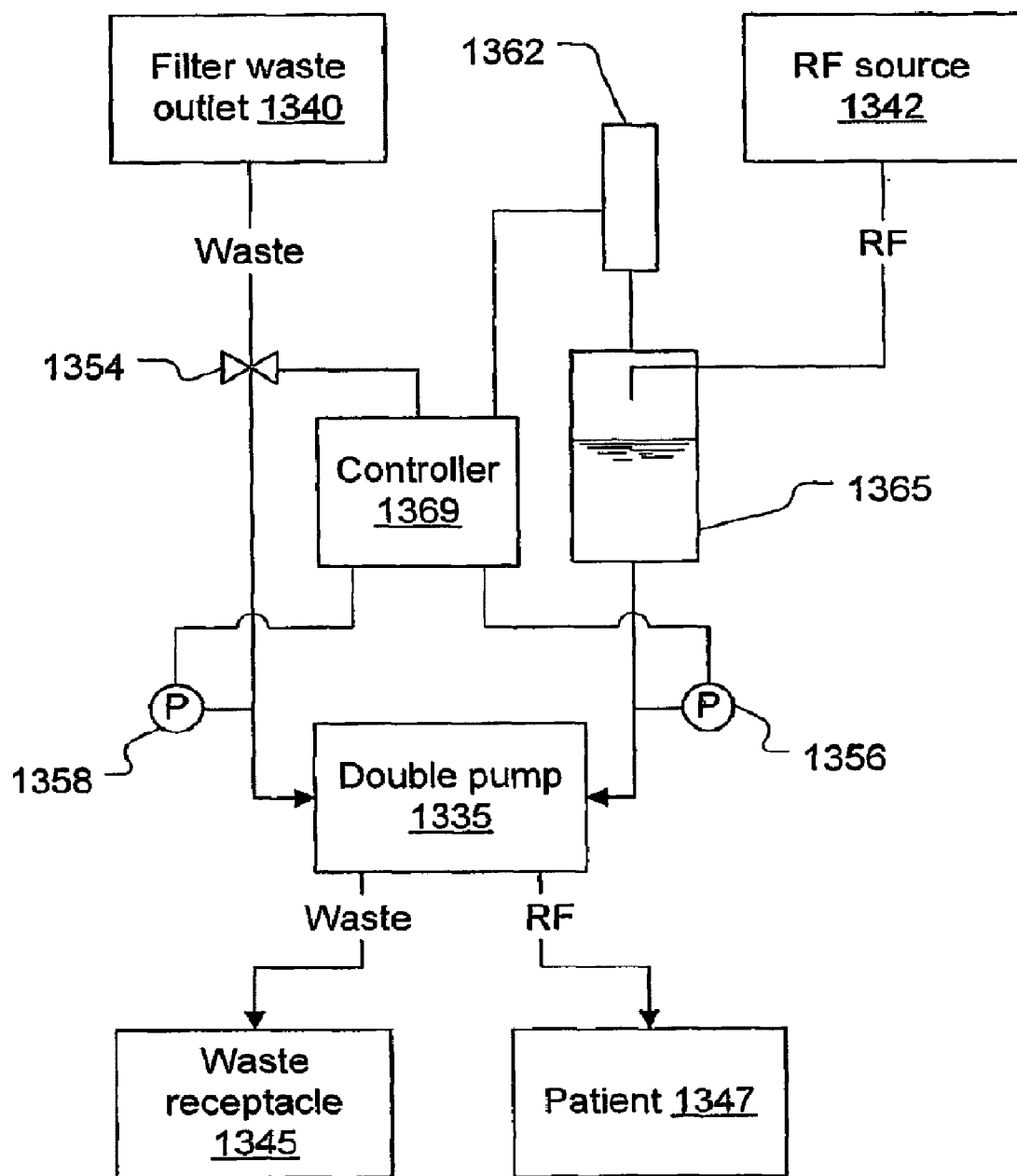

Fig. 33

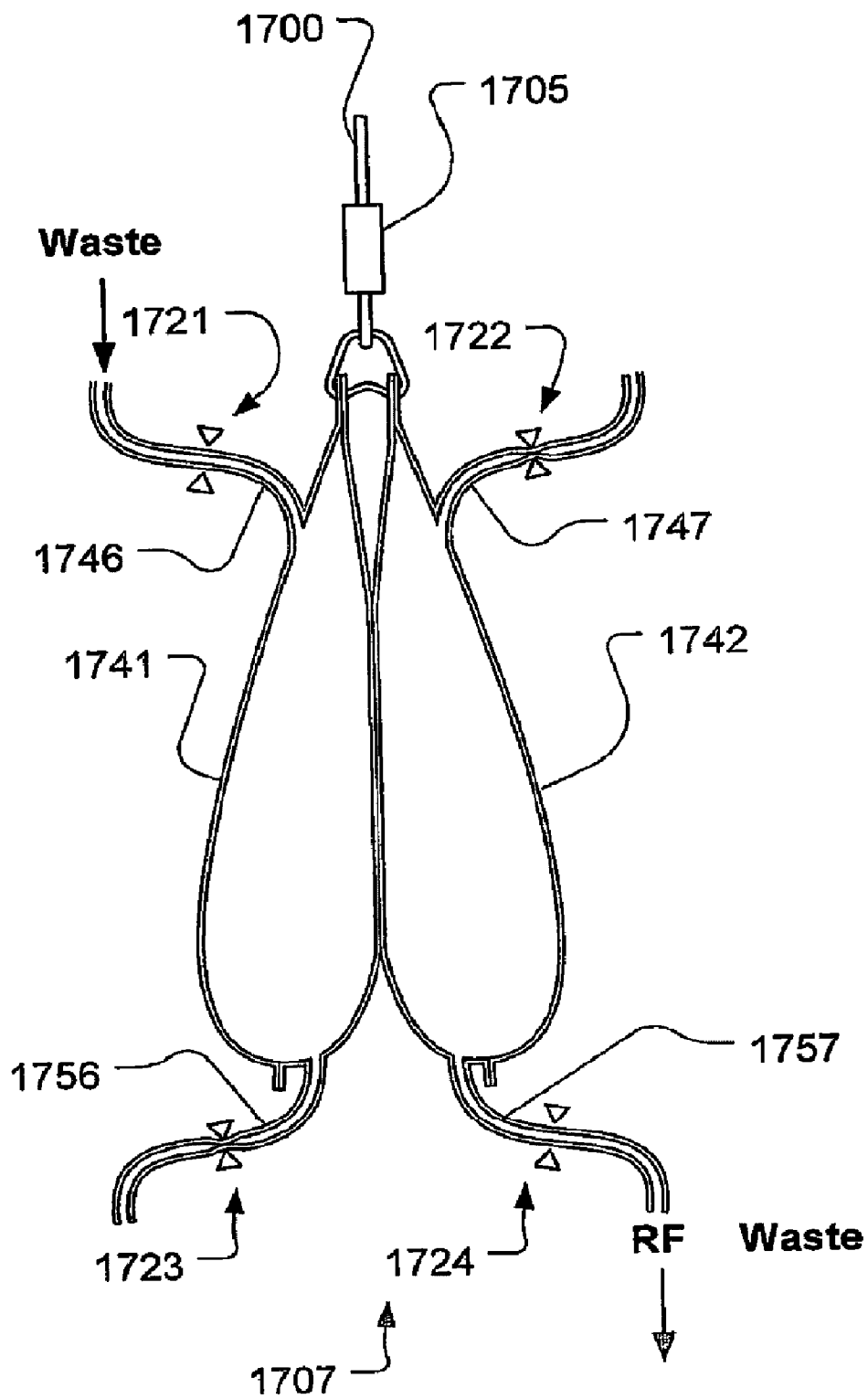

Fig. 34

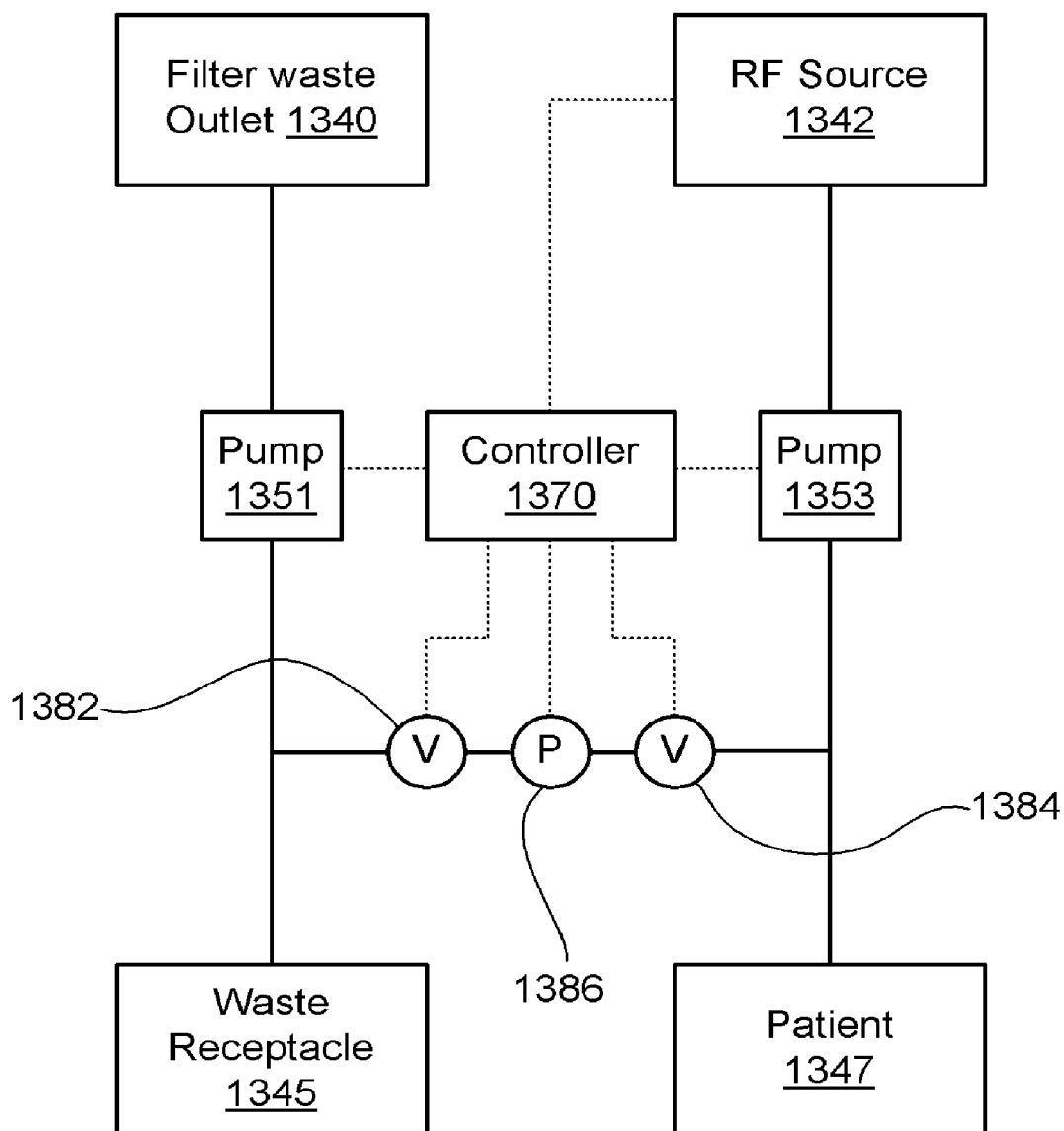

FIG. 35

**WASTE BALANCING FOR
EXTRACORPOREAL BLOOD TREATMENT
SYSTEMS**

**CROSS-REFERENCE TO RELATED
APPLICATIONS**

[0001] The present application is a continuation-in-part of U.S. patent application Ser. No. 10/544,124, filed Aug. 1, 2005, currently pending, which is a national stage entry of International Application No. PCT/US04/00921, filed Jan. 14, 2004, which claims the benefit of U.S. Provisional Application No. 60/440,176, filed Jan. 15, 2003, all of which are hereby incorporated by reference herein in their entireties.

SUMMARY

[0002] A fluid circulating system for medical use may evaluate a characteristic relating to waste removed from a patient and on that basis control a replacement fluid parameter. The waste characteristic evaluated in the present invention may be weight, volume, flow rate, concentration, and/or others, for example. Similarly, the replacement fluid parameter controlled may be weight, volume, flow rate, concentration, and/or others, for example. More than one waste characteristic may be evaluated to provide a redundant check on accuracy. Likewise, more than one replacement fluid parameter may be controlled. The control may be implemented, in a system for treating renal failure, to balance waste removed from a patient's blood against replacement fluid added to the patient's blood, for example. The control may be based on a desired filtration factor or ultrafiltration amount, for example.

BRIEF DESCRIPTION OF THE DRAWINGS

- [0003] FIG. 1 is a diagrammatic depiction of a waste balancing system for use in a fluid circulating system.
- [0004] FIGS. 2, 3, 4, and 5 are illustrations of various possible states of the waste balancing system of FIG. 1.
- [0005] FIGS. 6, 8, 9A, and 9B are diagrammatic depictions of the waste balancing system of FIG. 1 incorporating various pressure elements.
- [0006] FIG. 7 is an illustration of a possible state of the system of FIG. 6.
- [0007] FIG. 10 is a schematic representation of a blood treatment system.
- [0008] FIG. 11 is a diagrammatic depiction of a multiple balancing system.
- [0009] FIG. 12 is a side elevational drawing of a hemofiltration machine.
- [0010] FIG. 13 is a diagrammatic depiction of a waste balancing system.
- [0011] FIGS. 14, 15, 16, 17, and 18 are illustrations of alternative embodiments of multiple balancing systems.
- [0012] FIGS. 19, 20, 21, 22A, 22B, 23A, 23B, 24A, 24B, 25A, 25B, 26 and 27 are diagrammatic depictions of fluid circulating systems with alternative waste balancing systems.
- [0013] FIG. 28 is a flowchart of a method for a blood treatment system involving evaluation characteristics and control parameters.
- [0014] FIG. 29 illustrates an embodiment employing a combination of mass-sensing and fixed combined volume to provide for providing for net fluid balance of a patient during treatment.

- [0015] FIG. 30 illustrates a constant displacement mechanism for balancing waste and replacement fluid flows for maintaining net fluid balance of a patient during treatment.
- [0016] FIG. 31 illustrates an operating context for the device of FIG. 30.
- [0017] FIG. 32 illustrates a two-pump mechanism for maintaining fluid balance of a patient during treatment.
- [0018] FIG. 33 illustrates another operating context for the device of FIG. 30.
- [0019] FIG. 34 illustrates a constant combined mass mechanism for maintaining fluid balance of a patient during treatment.
- [0020] FIG. 35 illustrates a two-pump mechanism for maintaining fluid balance of a patient during treatment.

DETAILED DESCRIPTION

- [0021] An example of a waste balancing system for use in a fluid circulating system is shown in FIG. 1. Waste balancing system 108 includes container 110, flexible bag 120, valve 140, pressure element 150, and flexible bag 160. Container 110 is rigid and defines an interior volume, height, and width. Container 110 accommodates flexible bag 120. Flexible bag 120 may contain replacement fluid for a patient undergoing hemofiltration, for example. Flexible bag 120 is depicted in a full state in FIG. 1. That is, flexible bag 120 is filled with fluid 130 up to the maximum capacity of flexible bag 120. The height of flexible bag 120 varies with the amount of fluid it contains. In particular, the height of flexible bag 120 may vary directly in proportion to the amount of fluid it contains, with no air permitted in flexible bag 120. Valve 140 is located at the bottom of container 110 and defines a passage from the interior of flexible bag 120 to the exterior of container 110. Valve 140 permits fluid 130 to communicate with pressure element 150.
- [0022] A second flexible bag 160 is placed on top of flexible bag 120. Flexible bag 160 may have characteristics similar to flexible bag 120. In particular, the height of flexible bag 160 may vary with the amount of waste contained by flexible bag 160, in the same proportion that the height of flexible bag 120 varies with the amount of fluid contained by flexible bag 120. Flexible bag 160 may be configured to receive waste, but is shown in FIG. 1 as being empty.
- [0023] Pressure element 150 permits replacement fluid 130 to flow out of container 110 through valve 140 only when replacement fluid 130 at valve 140 is subject to a predetermined amount of fluid pressure. That predetermined amount may be equal to the pressure experienced at valve 140 when flexible bag 120 is full and flexible bag 160 is empty. This full state is represented by the level labeled "F" in FIG. 1. In that case, pressure element 150 only permits fluid 130 to flow out of container 110 when fluid 130 at valve 140 is subject to fluid pressure greater than that caused by the weight of fluid 130 when flexible bag 120 is full and flexible bag 160 is empty.
- [0024] Waste balancing system 108 may have an empty sensor 162. Empty sensor 162 is designed and adapted to sense when replacement fluid 130 has been depleted to or below the empty level "E" shown in FIG. 1. Empty sensor 162 may be located near the bottom of container 110 at the approximate height of level E, near pressure element 150, or elsewhere in a fluid circulating system.
- [0025] Empty sensor 162 may include a waste bag sensor designed to sense when the flexible bag 160 has expanded with waste to the point where the bottom of flexible bag 160 has dropped from the F position shown in FIG. 1 down to level

E. Such a waste bag sensor may include an optical sensor set to distinguish the optical characteristics of waste from those of replacement fluid. In that case, the optical sensor may be located near or within container 110 at level E. Alternatively, the waste bag sensor may include a mechanical sensor cooperating between container 110, flexible bag 160, and/or flexible bag 120. In that case, the mechanical sensor may be located at least partly within container 110 and may sense when the bottom of flexible bag 160 and/or the top of flexible bag 120 has dropped to level E.

[0026] Alternatively, empty sensor 162 may include a flow sensor designed to sense flow of replacement fluid out of container 110. Such a flow sensor may be located at valve 140 or downstream thereof. The flow sensor may include a flow meter designed to measure the flow amount of replacement fluid that has exited flexible bag 120. This flow amount would be compared to the available amount of replacement fluid that was initially available for exiting flexible bag 120. For example, the available amount may be the capacity of flexible bag 120 minus any amount of replacement fluid 130 that remains when flexible bag 120 is reduced to level E or otherwise considered empty. This comparison may be done automatically with a controller.

[0027] Alternatively, a flow sensor may comprise a pump sensor designed to sense operation of a pump downstream of valve 140. Such a pump sensor may for example sense the amount of time the pump is pumping replacement fluid exiting flexible bag 120 or the number of cycles (e.g. rotations) of a positive displacement pump or prime mover. With knowledge of the flow rate associated with the pump, a pumping period or number of cycles may be identified to approximate that required to pump all of the available replacement fluid 130 out of flexible bag 120. The pump may operate continuously or intermittently. When the pump has operated for an aggregate amount of time equal to or slightly less than the pumping period, the pump sensor would indicate that flexible bag 120 should be considered empty.

[0028] Empty sensor 162 may signal an alarm to indicate that flexible bag 120 is empty. The alarm may be audible, visual, or electronic. An electronic alarm could be conveyed to a circulation system controller for appropriate action. The circulation system controller may be an automatic system co-located with waste balancing system 108 or may be located remotely.

[0029] FIG. 2 shows waste balancing system 108 in a temporary state in which waste 170 has just been added to flexible bag 160, but before pressure element 150 has permitted passage of any replacement fluid 130 from flexible bag 120. This over-full state is represented by the level labeled "O.F." in FIG. 2. This state may be merely instantaneous, lasting only long enough for pressure element 150 to sense the additional pressure caused by the addition of waste 170 and to permit passage of replacement fluid.

[0030] Waste balancing system 108 may include over-full sensor 164. Over-full sensor 164 may be used to sense the accumulation of waste in flexible bag 160. When over-full sensor 164 senses that the top of flexible bag 160 has risen to level O.F., over-full sensor may indicate that condition to a controller which in turn may control pressure element 150 to permit passage of replacement fluid 130 through valve 140. This sensing and control may replace or supplement the sensing function of pressure element 150. When that function is replaced, pressure element 150 need not sense the pressure; it merely needs to control the pressure under control of the

controller. When that function is supplemented, the over-full sensor and the controller may act as a redundant check on the pressure sensing function of pressure element 150 to ensure accuracy. The over-full sensor may signal an alarm when it senses that the combined height of flexible bags 120 and 160 reaches the O.F. level. In a system designed to have the combined height normally below the O.F. level, the alarm may alert the patient, an operator, or a remote monitor of possible malfunction.

[0031] FIG. 3 shows an instantaneous state in which pressure element 150 has sensed the additional pressure caused by waste 170 in flexible bag 160 and in response has permitted some of replacement fluid 130 to flow out of container 110 as flow 180. Flow 180 may be directed to a patient in need of replacement fluid. In this instantaneous state, the combined height of flexible bag 120 and flexible bag 160 in container 110 is above the F level but is below the O.F. level described in connection with FIG. 2. Flow 180 continues until the combined height of flexible bag 120 and flexible bag 160 has been reduced again to F.

[0032] FIG. 4 shows a stable state following the state shown in FIG. 3. In this stable state, the combined height of flexible bag 120 and flexible bag 160 has been reduced again to F, causing flow 180 to cease.

[0033] Note that the above embodiment may employ a level sensor 164A instead of pressure sensing (by means of pressure element 150) as a means for determining whether the volume of replacement fluid sent to the patient is equal to the volume of waste withdrawn. According to the foregoing description, waste balancing system 108 may be controlled to supply replacement fluid corresponding to a characteristic of the removed waste. The characteristic may be volume (when a level sensor is used) and/or mass (when pressure element 150 senses pressure).

[0034] For example, it may be appropriate to control replacement fluid based on waste mass if the density of the removed waste may be variable or different than that of the replacement fluid. FIG. 5 shows a stable state for waste balancing system 108 after heavy waste 172 has been added to flexible bag 160. In this example, heavy waste 172 has higher density than replacement fluid 130. The pressure at valve 140 is the same as that shown in FIG. 1 and FIG. 4. Although the combined height of flexible bag 120 and flexible bag 160 is lower than the F level, the pressure at valve 140 has been maintained because heavy waste 172 has higher density than replacement fluid 130. Thus, the state shown in FIG. 5 may be reached from the state shown in FIG. 1 by adding heavy waste 172 and permitting pressure element 150 to maintain the fluid pressure at valve 140 by releasing some of replacement fluid 130 through valve 140. The example of FIG. 5 may be used to provide a patient with replacement fluid in an amount determined on the basis of the mass of removed waste.

[0035] FIG. 6 depicts an exemplary pressure element that may be used in conjunction with waste balancing system 108. Pressure element 650 consists of conduit 652, which rises to whatever height is necessary to maintain a desired pressure at valve 140. For example, conduit 652 is shown rising to a height corresponding to level F. This height may be fixed during manufacture of waste balancing system 108.

[0036] Alternatively, the height of conduit 652 in FIG. 6 may be adjustable. The proper height of conduit 652 may be determined by first raising conduit 652 to a starting height well above F. Second, flexible bag 120, full of replacement fluid 130 as shown, is inserted into container 110 along with

flexible bag 160 in its empty state. Third, conduit 652 is then gradually lowered from the starting height to the height at which replacement fluid 130 first begins to flow out of conduit mouth 654. Fourth, conduit 652 is fixed at that first-flow height for operation of waste balancing system 108.

[0037] FIG. 7 illustrates the pressure element of FIG. 6 in an instantaneous state after addition of waste 170 into flexible bag 160 bears down on flexible bag 120. In this state, pressure element 650 has sensed the additional pressure caused by waste 170 in flexible bag 160 and in response has permitted some of replacement fluid 130 to flow out of container 110 as flow 780. Flow 780 may be directed to a patient in need of replacement fluid. In this instantaneous state, the combined height of flexible bag 120 and flexible bag 160 in container 110 is above the F level but is below the O.F. level described in connection with FIG. 2. Flow 780 continues until the combined height of flexible bag 120 and flexible bag 160 has been reduced again to F.

[0038] FIG. 8 depicts another exemplary pressure element for use in conjunction with waste balancing system 108. Pressure element 850 consists of clamp 852, conduit 853, and stepper motor 858. Clamp 852 comprises clamping elements 854 and 856 which cooperate to squeeze conduit 853 with a certain amount of force. The amount of force is that necessary to maintain desired fluid pressure at valve 140 as described above.

[0039] For example, the force of clamp 852 in FIG. 8 may be adjustable. Stepper motor 858 may be operated to cause clamp 852 to squeeze conduit 853 with various amounts of force. An operator installing waste balancing system 108 in its place of operation, such as a home, may first apply a very high amount of force squeezing conduit 853. Second, the operator may place flexible bag 120 in its full state into container 110, along with flexible bag 160 in an empty state. Third, the operator may gradually reduce the amount of force squeezing conduit 853 by adjusting stepper motor 858 until replacement fluid 130 starts to be released as flow 880. Fourth, the amount of force is fixed at that first-flow amount of force for operation of waste balancing system 108.

[0040] Instead of using an operator, this process may be carried out automatically with controller 890. Controller 890 may control stepper motor 858 to gradually reduce the amount of force squeezing conduit 853 until optical sensor 892 senses when replacement fluid 130 is first released as flow 880. Controller 890 may control stepper motor 858 to squeeze conduit 853 with that first-flow amount of force during operation of waste balancing system 108, thereby maintaining the desired pressure at valve 140.

[0041] Controller 890 may function as the circulation system controller referenced above in connection with FIG. 1.

[0042] Alternatively, stepper motor 858, controller 890, and optical sensor 892 may be omitted and the force of clamp 852 may be set mechanically. For example, the amount of force used to squeeze conduit 853 may be predetermined during manufacture of waste balancing system 108 and fixed by applying clamp 852 to conduit 853 with the predetermined amount of force either during manufacture or installation. Or, the amount of force used to squeeze conduit 853 may be mechanically adjustable, for example.

[0043] In the case of a mechanically adjustable clamp, an operator installing waste balancing system 108 in its place of operation such as a home, may first apply a very high amount of force squeezing conduit 853. Second, the operator may place flexible bag 120 in its full state into container 110, along

with flexible bag 160 in an empty state. Third, the operator may gradually reduce the amount of force squeezing conduit 853 by mechanically adjusting clamp 852 until replacement fluid 130 starts to be released as flow 880. Fourth, the amount of force is fixed at that first-flow amount of force for operation of waste balancing system 108.

[0044] FIG. 9 shows another alternative pressure element comparable to that described in connection with FIG. 8. In FIG. 9, pressure element 950 consists of pressure bag 954 in fluid communication with pressure body 952 through pressure conduit 956. The weight of liquid in pressure bag 954 and the height of pressure bag 954 determines the pressure applied by pressure body 952 to squeeze conduit 953. Thus, the force used to squeeze conduit 953 may be adjusted by varying the amount of liquid in pressure bag 954 and/or the height of pressure bag 954. The appropriate amount of force may be determined by detecting when replacement fluid 130 is first released as flow 980 through valve 140 in like manner described above.

[0045] Waste balancing system 108 may be used as waste balancing system 8 in blood treatment system 10 depicted in FIG. 10. The arrangement of FIG. 10 facilitates a method for clearing a patient's blood of toxins by providing a protocol involving removing blood from the patient at a rate of at least 300 ml/min, at least partially clearing the blood of uremic toxins to create cleared blood, and returning the cleared blood to the patient. The protocol can be carried out at least four times per week. A patient blood withdrawal conduit 12 is connected to the vascular system of a patient 14 at a location 16 which, in preferred embodiments, is a high-flow rate valve port. Blood withdrawal conduit 12 is routed through a pump 18 and supplies blood to a blood treatment unit 20 via an inlet port 22. In preferred embodiments, blood treatment unit 20 is a hemofilter. Alternatively, blood treatment unit 20 may be a dialysis machine. Treated blood, from which waste product has been removed by blood treatment unit 20, exits blood treatment unit 20 at outlet 24 and is delivered, via conduit 26, to the vascular system of patient 14 preferably by way of location 28 which, in preferred embodiments, is a high-flow rate port. An ultrasonic detector 30 can be provided along conduit 26 between blood treatment unit 20 and patient 14 to detect any or all of flow rate, air bubbles (foam), and hematocrit. A safety clamp 32 can be provided as well to stop flow if detector 30 indicates the presence of unacceptable levels of air bubbles.

[0046] Waste product (waste filtrate in a hemofiltration system) exits blood treatment unit 20 via port 33 and passes through conduit 34 into waste balancing system 8. Conduit 34 passes through a pump 40. A blood detector 35 can be positioned along conduit 34 to detect any leaks in a filter within blood treatment unit 20. The detector detects red blood cells which, if a filter rupture has occurred, will leak into conduit 34, rather than being returned to patient 14. The detector can be controlled by a treatment controller, and operably and electronically linked to a system that stops treatment. An articulated clamp 37 can be positioned along conduit 34 to control, or at least fine tune, the rate of flow through pump 40.

[0047] Waste balancing system 8 is fluidly connected to conduit 26 via a replacement fluid conduit 44 with a connection 48 between conduit 44 and conduit 26. Conduit 44 passes through a pump 50. Waste balancing system 8 need include only that amount of infusate required for a particular treatment. Where a bi-daily (every other day) protocol is indicated, waste balancing system 8 may initially contain from

about 8 to about 24 liters of infusate. Where a daily protocol is indicated, waste balancing system **8** may initially contain from about 8 to about 12 liters of infusate.

[0048] A sterile filter **47** is positioned in conduit **44** between pump **50** and conduit **26**.

[0049] Pumps **18**, **40**, and **50** may be individual peristaltic pumps or combined as a single peristaltic pump, for example.

[0050] When waste balancing system **108** is used as waste balancing system **8** in FIG. **10**, waste **170** may be delivered to flexible bag **160** by conduit **34** and replacement fluid **130** may be delivered from flexible bag **120** to patient **14** via conduit **44**.

[0051] Alternatively, waste balancing system **8** may comprise a flow meter for measuring the amount of waste flowing through conduit **34**. A controller may then control pump **50** to pump an amount of replacement fluid selected on the basis of the measured waste flow. For example, to operate in a balanced condition, the controller may control pump **50** to pump an amount of replacement fluid equal to the measured waste flow.

[0052] FIG. **11** shows multiple balancing system **408**. Multiple balancing system **408** has waste balancing system **208** and waste balancing system **308**. Waste balancing system **208** and waste balancing system **308** may both be structurally identical to waste balancing system **108** depicted in FIG. **1** or waste balancing system **908** depicted in FIG. **13**, for example. In multiple balancing system **408**, one of the two waste balancing systems **208** and **308** may be functioning as described above in connection with FIGS. **2** through **4** while the other one is being restored to the initial state depicted in FIG. **1**.

[0053] For example, FIG. **11** depicts waste balancing system **208** in its initial state, i.e., full of replacement fluid and containing no waste fluid. Waste balancing system **308** is shown in its final state, i.e., substantially empty of replacement fluid and full of waste fluid. These conditions may result from operating multiple balancing system **408** for one half of a complete cycle, as follows.

[0054] During the first half of a cycle, pumps **391** and **392** are activated, causing waste **370** from a patient to travel from waste line **234** into flexible bag **360**. The pressure from the weight of waste **370** forces an equivalent weight of replacement fluid **330** to be released from flexible bag **320** through valve **340**, as regulated by pressure element **350**, and is pumped by pump **392** to a patient via replacement line **244**. The first half of the cycle is complete when flexible bag **320** is depleted down to level E as detected by empty sensor **362**, for example.

[0055] When the first half of the cycle is completed, pumps **391** and **392** are deactivated, and pumps **291**, **292**, **393**, and **394** are activated, initiating the second half of the cycle. The activation of pumps **291** and **292** causes waste **270** from the patient to travel from waste line **234** into flexible bag **260**. The pressure from the weight of waste **270** forces an equivalent weight of replacement fluid **230** to be released from flexible bag **220** through valve **240**, as regulated by pressure element **250**, and may be provided to a patient via replacement line **244**. Activation of pump **393** causes replacement fluid **430** from replacement fluid source **420** to flow into flexible bag **320**. Activation of pump **394** causes waste **370** that accumulated during the first half of the cycle in flexible bag **360** to be transported to waste dump **460**. The depletion of flexible bag **220** down to level E may be detected by empty sensor **262**, for example. The second half of the cycle is complete when flexible bag **220** is depleted down to level E, flexible bag **320**

is fully replenished with replacement fluid **430**, and flexible bag **360** is emptied of waste **370**.

[0056] A new cycle begins with deactivation of pumps **291**, **292**, **393**, and **394**, and activation of pumps **391**, **392**, **293**, and **294**. The activation of these pumps returns waste balancing system **208** from a depleted state to the full state depicted in FIG. **11**.

[0057] In the embodiment of FIG. **11**, replacement fluid source **420** may be many times larger than flexible bags **220** and **320**, and waste dump **460** may be many times larger than flexible bags **260** and **360**. This permits waste balancing systems **208** and **308** to be compactly located together remote from replacement fluid source **420** and waste dump **460**. In this case, waste balancing system **208** and waste balancing system **308** may be many times smaller than, but structurally similar to, waste balancing system **108** depicted in FIG. **1** or waste balancing system **908** depicted in FIG. **13**, for example.

[0058] Alternatively, pressure elements **250** and **350** may be replaced by weight scales and a controller adapted to maintain a constant weight in containers **210** and **310** in multiple balancing system **408**. In this case, the controller would control the system's pumps to pump replacement fluid in response to the weight of waste added to container **210** and **310**.

[0059] FIG. **14** illustrates such a system. Multiple balancing system **508** employs scales **251** and **351** instead of pressure elements **250** and **350**, respectively.

[0060] Alternatively, a system may employ both scales and pressure elements as redundant controls. When both the scales and the pressure elements are functioning as described above, the redundancy improves accuracy. This may be thought of as reducing the signal-to-noise ratio of the data used as evaluation characteristics. On the other hand, when one or more of the scales or pressure elements fails, the redundancy ensures continuous operation.

[0061] FIG. **15** illustrates an example of a redundant system. Redundant system **608** may normally operate in a selected one of the modes described above with respect to FIG. **11** and FIG. **14**. If the selected mode encounters difficulty such as faulty equipment or an alarm condition, redundant system **608** may switch to another of the modes. For example, if redundant system **608** normally operates in the scale mode described in connection with FIG. **14** using a controller to determine the amount of replacement fluid to pump based on the measured weight of container **210**, a problem with the controller may prevent proper operation of redundant system **608**. In that event, redundant system may switch to the pressure element mode of operation described in connection with FIG. **11**.

[0062] If redundant system **608** normally operates in the pressure element mode, for example, redundant system **608** may concurrently operate in the scale mode as a check on the accuracy of operation. If a discrepancy is detected, the system may automatically correct itself or signal an alarm condition.

[0063] When multiple balancing system **408** is used as waste balancing system **8** in FIG. **10**, waste may be delivered to waste line **234** by conduit **34**, and replacement fluid may be delivered from replacement fluid line **244** to conduit **44**.

[0064] FIG. **12** shows hemofiltration machine **516**. Hemofiltration machine **516** may employ multiple balancing system **408** to replace waste, removed from a patient by hemofilter **534**, with replacement fluid. Hemofilter **534** may form an integrated part of disposable cartridge **518**, if desired. The elements of multiple balancing system **408** may be distrib-

uted in hemofiltration machine **516** as follows, for example. Flexible bags **220**, **260**, **320**, and **360** may be contained in disposable cartridge **518** in slot **527**. Indentations (not shown) on chassis panel **526** register with comparable indentations (also not shown) on door **528** when door **528** is slid along rails **531** to sandwich cartridge **518** between door **528** and chassis panel **526**. Upon registration, these indentations may combine to form containers **210** and **310**. The remaining elements of multiple balancing system **408** as described in connection with FIG. **11** may be contained within hemofiltration machine **516**. Alternatively, replacement fluid source **420** and/or waste dump **460** may be situated external to hemofiltration machine **516** with appropriate connections to pumps **292**, **293**, **393**, and **394** within hemofiltration machine **516**.

[0065] Flexible bags **120**, **160**, **220**, **260**, **320**, and **360** as described are expandable containers. Any or all of these may be replaced with other expandable containers. For example, such an expandable container may comprise accordion or flexible sides with a rigid top and bottom. Or, an expandable container may comprise a flexible elastic bag. Alternatively, instead of using an expandable container, some or all of flexible bag pairs **120/160**, **220/260**, and **320/360** may be replaced with a piston or other partition in sealed moveable engagement with the sides of container **110**, **210**, or **310**.

[0066] FIG. **13** depicts waste balancing system **908**. Waste balancing system **908** operates similarly to waste balancing system **108** but flexible bag pair **120/160** has been replaced with piston **981** in sealed moveable engagement with the sides of container **110**. As waste **170** is added on top of piston **981**, piston **981** can move down in order to push replacement fluid **130** out of container **110** through valve **140**. This movement may be sensed and/or controlled by pressure element **150**. The amount of replacement fluid **130** that exits container **110** below piston **981** through valve **140** may be balanced against the amount of waste added above piston **981** in container **110**. For example, pressure element **150** may sense and/or control the passage of replacement fluid **130** through valve **140** in like manner describe above. Pressure element **150** may maintain a constant fluid pressure at valve **140** or a constant level of the combined height or weight of waste **170** and replacement fluid **130**.

[0067] In any of the embodiments described herein, a waste balancing system may be operable to achieve balance, ultrafiltration, and/or bolus conditions.

[0068] In a balance condition, the amount of replacement fluid leaving a waste balancing system is approximately equal to the amount of waste entering a waste balancing system. This may be indicated when a patient is to receive replacement fluid in an amount approximately equal to the amount of waste removed from the patient's blood stream. In an ultrafiltration condition, the amount of replacement fluid leaving a waste balancing system is less than the amount of waste entering a waste balancing system. This may be indicated when a patient is to receive replacement fluid in an amount less than the amount of waste removed from the patient's blood stream. In a bolus condition, the amount of replacement fluid leaving a waste balancing system is greater than the amount of waste entering a waste balancing system. This may be indicated when a patient is to receive replacement fluid in an amount greater than the amount of waste removed from the patient's blood stream.

[0069] Any given waste balancing system disclosed herein may be automatically or manually adjustable before or during operation to achieve one or more of the balance, ultrafiltra-

tion, and bolus conditions. For example, the extent of ultrafiltration may be adjusted to achieve a desired amount of net fluid loss for a patient. Pressure element **150** may be set to maintain the combined fluid level in container **110** at a fixed or increasing level higher than F. As another example, some percentage or absolute amount of the waste entering waste balancing system **108** may be siphoned off without being added to container **110**. Waste may be siphoned off before reaching waste balancing system **8**.

[0070] FIG. **14** depicts multiple balancing system **508**. Multiple balancing system **508** is comparable to multiple balancing system **408** depicted in FIG. **11**, except that sensing functions of pressure elements **250** and **350** are performed by scales **251** and **351**, respectively. Scale **251** weighs container **210** in order to detect the change in weight caused by waste **234** entering flexible bag **270**. This information is provided to an operator (not shown). The operator may be an electronic controller, an attendant, a remote medical professional, or the patient, for example. The operator uses the information as an evaluation characteristic and determines therefrom a control parameter for operation of pump **292**. For example, if it is desired to operate multiple balancing system **508** in a balanced condition and waste removed from a patient is added to flexible bag **260** in container **210**, the operator may determine that pump **292** should be operated so as to cause replacement fluid **230** to be pumped out of container **210** and provided to a patient via conduit **244** in an amount required to maintain container **210** at a constant total weight. The operator may use a flow rate associated with pump **292** as a control parameter. Or, the operator may simply use an on/off control for pump **292** as a control parameter, controlling pump **292** to be on until such time as scale **251** indicates to the operator that the weight of container **210** has been maintained. Thus, the patient may be provided replacement fluid in an amount (mass) equal to the mass of the removed waste.

[0071] Waste balancing system **308** may be operated in similar fashion in a cycle alternating with waste balancing system **208** as described in connection with FIG. **11** in order to provide the patient uninterrupted availability or constant flow of replacement fluid from multiple balancing system **508**. A third waste balancing system (not shown) may be available to switch in as a backup in case waste balancing system **208** or waste balancing system **308** becomes unavailable or inoperable. Thus, uninterrupted availability of replacement fluid may be assured even if a waste balancing system in multiple balancing system **508** is out of service.

[0072] As shown in FIG. **14**, multiple balancing system **508** may be implemented as a tandem waste balancing system without a third waste balancing system.

[0073] FIG. **15** illustrates multiple balancing system **608**. Multiple balancing system **608** is similar to multiple balancing system **508** but employs both pressure element **250** and scale **251**. For example, pressure element **250** may provide redundancy as a back-up to or accuracy check on the operations described in connection with scale **251**.

[0074] FIG. **16** illustrates multiple balancing system **708**. Multiple balancing system **708** is comparable to multiple balancing system **408** described in connection with FIG. **11**, except for the addition of cap **211** (and cap **311**). Cap **211** is fixed at a certain height in container **210**. For example, cap **211** may be installed at a selected height F by clamping cap **211** to container **210** with clamps **212**. Once installed in place, cap **211** defines and fixes a certain maximum volume below cap **211** in container **210**. This maximum volume serves as an

upper limit on the combined volume of flexible bags 260 and 220. During operation of waste balancing system 208, when the combined volume of flexible bags 260 and 220 equals the maximum volume, no more waste can be added to flexible bag 260 unless an equal or greater volume of replacement fluid exits flexible bag 220. Pressure element 250 and empty sensor 262 may be included for redundancy.

[0075] Waste balancing system 208 as shown in FIG. 16 may be initially set up as follows. First, flexible bag 220 is established in its full condition in container 210. Second, flexible bag 270 is established in its empty condition on top of and in contact with flexible bag 220 in container 210. Third, cap 211 is placed on top of and in planar contact with flexible bag 270. Fourth, cap 211 is fixed in place with clamps 212.

[0076] After waste balancing system 208 is set up as shown in FIG. 16, it may operate to balance waste against replacement fluid based on both volume and mass. Cap 211 may provide a volume-based evaluation characteristic and control parameter, and pressure element 250 may concurrently or alternatively provide a mass-based evaluation characteristic and control parameter.

[0077] FIG. 17 illustrates multiple balancing system 808. Multiple balancing system 808 is similar to multiple balancing system 708 except that pressure element 250 has been removed and scale 251 has been added. Additionally, cap 211 may be permanently pre-installed at level F, creating a permanent fixed-volume chamber within container 210 below cap 211. In operation, the fixed-volume chamber provides a mechanical volume-based evaluation criteria by sensing the volume of waste fluid received and also provides a mechanical volume-based control parameter by controlling the volume of replacement fluid provided to the patient. Scale 251 may provide the weight of container 210 as a secondary evaluation characteristic. During operation, if the secondary evaluation characteristic indicates a value outside of a pre-determined range or percentage variation, an alarm condition may be generated. For example, if the secondary evaluation characteristic indicates that the weight of container 210 has risen higher than an upper bound, an alarm condition may cause pump 291 to be deactivated. Or, if the secondary evaluation characteristic indicates that the weight of container 210 has fallen lower than a lower bound, an alarm condition may cause pump 292 to be deactivated.

[0078] Waste balancing system 308 may operate in a cycle opposite that of waste balancing system 208 in multiple balancing system 808.

[0079] FIG. 18 represents multiple balancing system 1008. Multiple balancing system 1008 is shown having identical containers 410 and 510. Container 410 defines a chamber 487 having a permanently fixed volume and comprising waste compartment 413 and replacement fluid compartment 489 divided by divider 415. Divider 415 may be a diaphragm, for example. Alternatively, waste compartment 413 and replacement fluid compartment 489 may each comprise a flexible plastic bag inside of chamber 487, with divider 415 being formed by fusing together the contacting portions of the two flexible plastic bags. Scale 451 reflects the combined weight of the contents of waste compartment 413 and replacement fluid compartment 489.

[0080] In the state shown in FIG. 18, container 410 has a waste-fluid-in valve open, permitting waste fluid to flow into waste compartment 413. A replacement-fluid-out valve is also open, permitting replacement fluid to flow out of replacement fluid compartment 489. When chamber 487 is full, the

addition of a volume of waste fluid to waste compartment 413 forces an equal volume of replacement fluid to exit replacement fluid compartment 489.

[0081] At the same time, container 510 is shown operating in a cycle opposite that of container 410. A waste-fluid-out valve is open, permitting waste fluid to flow out of waste compartment 513. A replacement-fluid-in valve is also open, permitting replacement fluid to flow into replacement fluid compartment 589. When chamber 587 is full, the addition of a volume of replacement fluid to replacement fluid compartment 589 forces an equal volume of waste fluid to exit waste compartment 513. In this manner, container 510 may be reset while container 410 is used to provide replacement fluid to a patient in need thereof. When waste compartment 413 becomes full or replacement fluid compartment 489 becomes empty, the cycle can be reversed, i.e., container 510 can provide replacement fluid to a patient while container 410 is reset.

[0082] While container 410 is providing replacement fluid to a patient or accepting waste fluid from a patient, scale 451 provides an additional margin of safety and reliability by reflecting the combined weight of the contents of waste compartment 413 and replacement fluid compartment 489. If the combined weight falls above or below a safety margin, an alarm condition may be indicated. As one possible result of such an alarm condition, the waste-fluid-in valve and replacement-fluid out valve of container 410 may be closed. Another possible result would be that only one of those two valves may be closed. For example, if the combined weight falls above a safety margin, the alarm condition may result in closing the waste-fluid-in valve while leaving open the replacement-fluid-out valve of container 410 until the combined weight is again within the safety margin.

[0083] Thus, fixed-volume chamber 487 makes available a volume-based evaluation characteristic and a volume-based control parameter. Scale 451 makes available a mass-based evaluation characteristic. Operation of the valves as described herein makes available a replacement flow on/off control parameter. A volume-based evaluation characteristic may be combined with a mass-based evaluation characteristic to determine appropriate values for control parameters to provide a desired amount of replacement fluid to a patient.

[0084] FIG. 19 exemplifies implementation of multiple balancing system 1008 in a blood treatment system 910. Blood treatment system 910 treats the blood of patient 914 with blood treatment unit 20. As illustrated in FIG. 19, blood treatment unit 20 may be a hemofilter 920.

[0085] FIG. 20 is similar to FIG. 19 except that FIG. 20 only has one container 410. While chamber 487 is being reset as described above, replacement fluid could be temporarily halted or it could be provided directly from replacement fluid source 420. If replacement fluid is temporarily halted, blood treatment system 910 may continue to operate but in an ultra-filtration condition.

[0086] FIG. 21 illustrates implementation of waste balancing system 108 in blood treatment unit 20. Blood treatment unit 20 may for example be dialysis machine 820.

[0087] FIG. 22 shows blood treatment system 910 combined with waste balancing system 8, patient scale 951, and controller 966. Controller 966 may detect all available evaluation characteristics and control all available control parameters. For example, patient scale 951 may provide controller 966 with the patient's weight as an evaluation characteristic.

Patient **914** may be weighed on patient scale **951**, intermittently or continuously, during operation of blood treatment system **910**.

[0088] The memory of controller **966** may store an ideal weight for patient **914**. Alternatively, the processor of controller **966** may calculate an ideal weight by averaging previous measurements of the weight of patient **914** as detected by scale **951** and stored in the memory of controller **966**. Or, controller **966** may determine the ideal weight by subtracting a desired ultrafiltration amount (or adding a desired bolus amount) to the weight of patient **914** at the beginning of treatment as detected by patient scale **951**.

[0089] Controller **966** may operate the pumps in blood treatment system **910** or waste balancing system **8** to provide an amount of replacement fluid to patient **914** necessary to maintain or achieve the ideal weight. For example, during treatment of patient **914** by blood treatment system **910**, if patient scale **951** detects a weight that exceeds the ideal weight for patient **914** by more than a threshold amount, controller **966** may activate the ultrafiltration pump to remove waste fluid from blood treatment unit **20** without providing a corresponding amount of replacement fluid to patient **914**, until scale **951** indicates that patient **914** is at an acceptable weight. An acceptable weight may be a weight at or below the ideal weight, for example.

[0090] Patient hydration sensor **959** senses the hydration level of patient **914**. For example, patient hydration sensor **949** may sense the density, color, and/or composition of blood removed from patient **914**. The patient hydration level may approximate the level of hydration (or dehydration) of patient **914** as a percentage of the patient's body mass that is liquid, for example. The patient hydration level is made available to controller **966** as an evaluation characteristic and may supplement or supplant data from scale **951**. For example, controller **966** may control the illustrated pumps to provide enough replacement fluid to maintain or achieve an acceptable hydration level stored in memory of controller **966** for patient **914**.

[0091] Replacement fluid source **420** may have an empty sensor **862** to indicate an alarm condition to controller **966**. Controller **966** may then make a connection over the Internet to order delivery of more replacement fluid, for example. Similarly, waste dump **460** may have full sensor **864** to indicate an alarm condition to controller **966**. Controller **966** may then make a connection over the Internet to request emptying of waste dump **460**, for example.

[0092] FIG. 23 shows waste balancing system **1108** implemented as the waste balancing system **8** of FIG. 22. Waste balancing system **1108** comprises flexible bag **160**, flexible bag **120**, full sensor **964**, and empty sensor **962**. Full sensor **964** is operable to detect when flexible bag **120** is full of replacement fluid. Empty sensor **962** is operable to detect when flexible bag **120** is empty. Full sensor **964** and empty sensor **962** provide input to controller **966**, which in turn operates the pumps shown. Controller **966** may control balancing system **1108** to provide replacement fluid to patient **914** until empty sensor **962** detects that flexible bag **120** is empty. At that point, controller **96** may control the pumps to reset balancing system **1108** by emptying waste from flexible bag **160** to waste dump **460** and refilling flexible bag **120** with replacement fluid from replacement fluid source **420**.

[0093] FIG. 24 is similar to FIG. 23 except that multiple balancing system **1208** comprises more than one waste balancing system. For example, multiple balancing system **1208** may consist of two or three waste balancing systems **1108**,

1109, and so forth. In this embodiment, when balancing system **1108** is being reset, balancing system **1109** may be operated to supply replacement fluid to patient **914** and receive waste fluid from blood treatment unit **20** to permit continuous operation of multiple balancing system **1208**.

[0094] FIG. 25 illustrates implementation of waste balancing system **1308**. Waste balancing system **1308** comprises a flow meter **1329** to measure waste removed from patient **914** and an RF pump **1339** to pump replacement fluid from replacement fluid source **420** to patient **914**.

[0095] The output of flow meter **1329** may be provided to controller **966**, which in turn controls RF pump **1339** to provide an appropriate amount of replacement fluid to patient **914**. For example, for a balanced condition, controller **966** may control RF pump **1339** to pump an amount of replacement fluid equal to the amount of removed waste detected by flow meter **1329**. For an ultrafiltration condition, controller **966** may control RF pump **1339** to pump an amount of replacement fluid less than the amount of removed waste detected by flow meter **1329**. For a bolus condition, controller **966** may control RF pump **1339** to pump an amount of replacement fluid greater than the amount of removed waste detected by flow meter **1329**.

[0096] Flow meter **1329** may use a strain gauge or laser Doppler to measure viscous flow, for example. Flow meter **1329** may use vortex shedding, orifice or nozzle pressure drop, or Pitot tube to measure turbulent flow, for example. Controller **966** may integrate over time a changing flow velocity detected by flow meter **1329** in order to determine the total amount of waste removed from patient **914** via blood treatment system **20** and waste pump **1349**.

[0097] Flow meter **1329** may be of a type that is less accurate at flow amounts below a minimum threshold. In that case, controller **966** controls waste pump **1349** to pump only when flow meter **1329** detects a flow amount greater than the minimum threshold. A buffer (not shown) between blood treatment unit **26** and flow meter **1329** may accumulate waste when waste pump **1349** is deactivated. A level sensor (not shown) in the buffer may indicate to controller **966** when the buffer has accumulated enough waste to ensure a flow amount greater than the minimum threshold, causing controller **966** to restart waste pump **1349**.

[0098] FIG. 26 illustrates waste balancing system **1408** implemented in blood treatment system **10**. Waste balancing system **1408** includes container **210** enclosing flexible bag **220**, flexible bag **260**, and cap **211** held by clamps **212**. Upon installation of waste balancing system **1408** in blood treatment system **10**, cap **211** is fixed at a desired position in container **210** by clamps **212**, thereby defining a fixed volume for the combination of flexible bag **220** and flexible bag **260**. A mass of removed waste is added to flexible bag **260**, forcing an equal mass of replacement fluid out of flexible bag **220** via conduit **44**. The fixed volume assures that waste is not added to flexible bag **260** in a volume greater than the volume of replacement fluid that exits flexible bag **220**.

[0099] FIG. 27 illustrates waste balancing system **1508** implemented in blood treatment system **10**. Waste balancing system **1508** comprises piston **981** sealed in slidable engagement within container **110**. A mass of waste **170** added to container **110** via conduit **34** bears down on piston **981**, causing piston **981** to slide downward in container **110** and force an equal mass of replacement fluid **130** to exit container **110** via conduit **44**. Piston **981** may slide continuously between its

illustrated position and the position shown in phantom. Piston **981** may alternately be replaced with a flexible diaphragm, for example.

[0100] Any of systems **108, 208, 308, 408, 508, 608, 708, 808, 908, 1008, 1108, 1208, 1308, 1408,** and/or **1508,** for example, may be used in waste balancing system **8** of the blood treatment system depicted in FIG. **10** or FIG. **22,** for example.

[0101] Any of the alarms described herein may be transmitted from a patient's location to a remotely located monitor. For example, an alarm generated at a patient's home may be automatically transmitted over an electronic communications network to a remote medical or maintenance facility for appropriate attention. An alarm may indicate to a doctor at a hospital, for example, that a patient undergoing hemofiltration at home may be in danger of losing a net quantity of fluid greater than a desired ultrafiltration amount. This is exemplified in the Internet connection depicted in FIGS. **22, 23, 24,** and **25.** Or, an alarm may indicate to a service provider, for example, that a customer's blood treatment system needs more replacement fluid supply or other service.

[0102] FIG. **28** is a flowchart of a method **2800.** Method **2800** may be performed automatically by an electronic controller. Alternatively, method **2800** may be performed manually by a patient at home. Method **2800** includes steps **2802, 2804, 2806, 2808,** and **2810.**

[0103] In step **2802,** the method selects one or more evaluation characteristic(s) for a blood treatment system. This selection may be predetermined by a provider of the blood treatment system and hardwired, coded, or implemented mechanically, for example. Alternatively, the selection may be made by an operator or an electronic controller based on current conditions.

[0104] In step **2804,** the method performs evaluation of the selected evaluation characteristic(s). This evaluation may be carried out automatically by electronic equipment connected to an electronic controller. Alternatively, the evaluation may be carried out automatically by mechanical equipment. Or, the evaluation may be carried out manually by a patient at home.

[0105] For example, if the selected evaluation characteristics include patient weight, the evaluation of step **2804** may be carried out automatically by a scale connected to an electronic controller. During the entire time the patient's blood is being treated, the patient may be seated on a platform containing a scale that continuously provides the patient's weight to an electronic controller.

[0106] In step **2806,** the method selects control parameters. The selection may be made dynamically as a result of step **2802** and/or step **2804.** For example, if accumulated waste volume is selected in step **2802** as an evaluation characteristic, step **2806** may select RF volume supplied as a control parameter. In another example, if step **2804** evaluates patient weight and finds it to be outside of a normal range, step **2806** may select multiple control parameters, such as RF volume supplied and RF mass supplied, as an additional safety measure.

[0107] In step **2808,** the method determines from the evaluation of step **2804** the desired result(s) in terms of control parameters selected in step **2806.** For example, if the evaluation of step **2804** determines that the patient weight is too high, step **2808** may determine that RF mass supplied should be less than accumulated waste mass by an amount equal to the patient's excess weight.

[0108] In step **2810,** the method controls to achieve the desired result in real time, i.e., during a treatment session. For example, if the desired result is to supply RF mass that is a certain amount less than accumulated waste mass, the method may control a waste balancing system to supply RF mass in an amount less than accumulated waste mass. Method **2800** may return to step **2802** or **2804.**

[0109] Any number of exemplary evaluation characteristics may be evaluated in order to determine a value for any number of exemplary control parameters. For example, fuzzy logic implemented in an electronic controller may determine that a certain combination of values determined upon evaluation of patient hydration, patient blood pressure, and patient temperature should result in controlling the alarm On/Off control parameter into an On state and the Treatment On/Off control parameter into an Off state. As another example, evaluation of the cleanliness of patient's blood and the desired treatment duration may determine an RF composition desired as a control parameter. Some exemplary evaluation characteristics may also be exemplary control parameters, and some exemplary control parameters may also be exemplary evaluation characteristics.

[0110] Referring now to FIG. **29,** a batch balancing device **1508** employs a single fixed volume vessel **1510** has an internal volume **1560** enclosing subvolumes **1500** and **1505** for replacement fluid and waste fluid respectively. The internal volume **1560** is fixed by means of a cap **1511** fixed by means of locks **1512** in a manner similar to that described with respect to foregoing embodiments. As waste fluid passes into subvolume **1505,** an equal volume of replacement fluid may be forced out of subvolume **1500.** Vessel **1510** may be large enough to contain an entire batch of replacement fluid for a treatment in the subvolume **1500** at the start of treatment. During treatment, the subvolume **1505** may fill with waste fluid and ultimately accommodate a volume resulting from an entire treatment. In this embodiment, therefore, no cycling of valves or pumps is required as each incremental volume of waste displaces a corresponding volume of replacement fluid progressively filling the subvolume **1505** and progressively emptying the subvolume **1500.** The result of the above may therefore be a proper balancing of waste and replacement fluid over the course of an entire treatment with no required cyclic operation.

[0111] Valves **1541, 1542, 1543,** and **1544** may be employed to initially fill subvolume **1500** and empty subvolume **1505** by appropriately opening and closing at appropriate times for filling and draining.

[0112] A refinement or alternative to the above is also illustrated: a scale **1551** may be employed to weigh an entire combined mass of replacement fluid and waste fluid to provide for constant fluid balance during treatment. In an embodiment relying solely on scale **1551,** the cap **1511** and locks **1512** may not be required. During treatment, waste may be pumped into the subvolume **1505.** This causes the total mass within the container **1510** to change unless replacement fluid is removed from subvolume **1500.** A controller (not shown in FIG. **29)** may control the flow of replacement fluid to maintain a constant total mass of the container **1510** and its contents in response to a weight indication from the scale **1551.**

[0113] Constant volume and weight may be used in concert to control a single batch system as illustrated in FIG. **29.** For example, weight may be used to provide an out-of-bounds signal to help guarantee the integrity of the constant volume

system. More particularly, a controller may receive a signal from the scale and if the total mass goes out of a predefined range during treatment, an error condition may be indicated by the controller. Otherwise, the system may rely on the constant volume mechanism, in which replacement fluid is displaced by waste to maintain fluid balance during treatment.

[0114] In an alternative embodiment, a signal from the scale indicating total mass may be used continuously to adjust the flow rate of replacement fluid. For example, the flow of replacement fluid may be smoothed by biasing the rate of flow of replacement fluid generated by the constant volume mechanism according to a weight signal. Thus, for example, if the total mass indicated by the scale 1551 is offset from a predefined value the flow of replacement fluid may be increased or retarded by a controller that controls an assist pump (not shown, but preferably a non positive displacement type pump such as a centrifugal or turbine pump) in the replacement fluid outflow path. Thus, when an irregular flow results from the constant volume mechanism, it may be smoothed by data from the scale 1551. Such irregular flow may result, for example, due to irregular flexing of the flexible envelopes 1560 and 1520 containing the subvolumes 1500 and 1505. Yet another option is to switch to constant mass control using the weight as a signal to control replacement fluid flow when the weight varies from a range around a predefined value. Note that the predefined weight value may be set as the initial value before treatment begins.

[0115] Referring now to FIG. 30, a double peristaltic pump 1300 pumps waste fluid and replacement fluid through respective lines 1305 and 1310. The double peristaltic pump 1300 may consist of two pumps on a common shaft (the shaft is not explicitly illustrated) or may be rotated by a drive that provides for equal displacement rate of both the waste and replacement fluid streams flowing through lines 1305 and 1310. The double pump's 1300 rotor 1302 engages both lines 1305 and 1310 to pump fluid in each simultaneously and at rates that are proportional, since both pump rates are governed by the same shaft speed (i.e., that of the rotor 1302). The lines 1305 and 1310 may be identical and the rotor 1302 may be configured to engage them identically such that the rates of pumping in both lines 1305 and 1310 remain identical. Lines 1305 and 1310 can be made from the same or similar tubing with substantially identical properties so as to achieve better balancing performance of flow rates through lines 1305 and 1310. For example, the tubing for lines 1305 and 1310 may be cut from a single production run to ensure the tubing properties are identical. As a result, the rate of flow of waste in one of the lines, say 1305, may be identical to a rate of flow of replacement fluid in the other line say 1310. FIG. 31 illustrates this context.

[0116] Referring now to FIG. 31, filter waste from a filter waste outlet 1340 is drawn by one line of a double pump 1335 which may be fashioned as illustrated and discussed with reference to FIG. 30. Simultaneously replacement fluid is pumped from a source 1342 through the other line of the double pump 1335. The replacement fluid may be pumped into a patient 1347 while waste is conveyed to a waste receptacle 1345. Note that the double pump 1335 may be of a type other than a peristaltic pump as illustrated in FIG. 30. For example, it may be of a non positive-displacement type such as a pair of turbine or centrifugal pumps driven by a common drive mechanism. Alternatively, it may be of a piston and cylinder, roots blower, diaphragm or other type of positive

displacement pump. Preferably, the pump is of a type that allows for hermetic isolation of fluid contents.

[0117] Most types of pumps, including peristaltic pumps, are characterized by pumping rates that are not perfectly proportional to rotor speed but rather to both rotor speed and pumping head. Thus, pressure of the waste and replacement fluid lines may be measured at a pump-inlet, pump-outlet, or both by pressure sensors as indicated at 1337 and 1338. The latter indicate pressure sensing at pump-inlet locations. A controller 1368 may control the pump speed or otherwise control the pumping rate so as not to generate a pressure difference across the double pump 1335 that is determined to correspond to equal flow rate through both the RF and waste lines. Thus, if the pressure at the inlet (illustrated) or pressure drop (not illustrated, but pressure-difference transducers could be used with taps at points upstream and downstream of the double pump 1335 or an additional set of pressure sensors located downstream of the double pump 1335 could be used) could be determined by the controller and if it ran above a predetermined value, the pump rate could be slowed (e.g., by reducing the rotor speed of a peristaltic pump as illustrated in FIG. 30) and if it dropped too low, the rate could be increased. Note that only an upper limit may be employed rather than an allowed band of pressure differences. Alternatively, the controller may halt treatment if the pressure head goes outside a predefined range. Alternatively, control valves (not shown) may be used to equalize the head across both portions of the double pump 1335 to ensure that flow rates will tend toward identity.

[0118] Because the flow rate of the double pump may vary according to rotor speed, calibration of the double pump 1335 may be necessary to properly correlate rotor speed with desired flow rate. A metering pump can be used to calibrate the flow rate of the double pump. For example, the replacement fluid source 1342 can include a metering pump which can provide a well-controlled and/or verifiable flow rate of purified water or replacement fluid to the replacement fluid line of the double pump 1335. Fluid can thus be provided at a known rate to the replacement fluid line of the double pump 1335 so as to calibrate the flow rate therethrough. By virtue of the shared rotor design and/or synchronized flow rates of the double pump 1335, calibration of flow rate in the replacement fluid line of the double pump using the metering pump would also provide calibration of the flow rate in the waste fluid line.

[0119] FIG. 32 illustrates another mechanism for controlling the rate of flow of replacement fluid such that it remains nearly identical to the rate of flow of waste removal. The configuration of FIG. 32 is similar to that of FIG. 31 except that instead of a single double pump 1335 (FIG. 31) separate pumps 1351 and 1353 are used for pumping waste and replacement fluid respectively. Respective throttling valves 1354 and 1352 in each fluid line create a pressure difference on either side thereof that is measured by respective pressure sensors 1361, 1363, 1362, and 1364. The latter apply pressure signals to a controller 1367 which regulates the pumping speed of the two pumps 1351 and 1353 to provide for identical (or a desired departure from identical rates as indicated by treatment requirements) flow rate of replacement fluid added to the patient 1347 and waste fluid drawn from a filter outlet 1340. In effect, the throttling valves 1354 and 1352 and pressure sensors 1361, 1362, 1352 and 1364 are used for flow measurement whereby the throttling of the flow and the pressure indicate flow rate according to a pressure drop versus flow rate curve which may be derived by suitable calibration.

A curve may include other parameters such as fluid temperature and density indicated by concentration sensors and temperature sensors.

[0120] The configuration of FIG. 35 is similar to that of FIG. 32. In contrast to the configuration of FIG. 32, a single pressure transducer 1386 is used to synchronize flow rates between the replacement fluid pump 1353 and the waste fluid pump 1351. The pumps 1351 and 1353 can be synchronized prior to a start of treatment such that pump 1351 conveys waste fluid therethrough at an identical rate to that at which pump 1353 conveys replacement fluid therethrough. Thus, replacement fluid can be added to the patient 1347 at the same rate at which waste fluid is withdrawn from filter outlet 1340.

[0121] To synchronize the pumps 1351 and 1353, the single pressure transducer 1386 is arranged between the output lines of the pumps. A valve 1382 can be provided between the output line of the waste pump 1351 and the pressure transducer 1386. Similarly, a valve 1382 can be provided between the output line of the replacement fluid pump 1353 and the pressure transducer 1384. A controller 1370 regulates operation of the pumps 1351 and 1353 responsive to signals from pressure transducer 1386. Controller 1370 can also operate the valves 1382, 1384 to change to between an open state during the synchronization process and a closed state during a treatment process. In addition, controller 1370 can communicate with a metering pump in replacement fluid source 1342 so as to calibrate the flow rate of the replacement fluid pump 1353, as described elsewhere herein.

[0122] During the synchronization process, the system may be disconnected from the patient 1347 and output lines of the pumps diverted to a waste or other receptacle. Valves 1382 and 1384 are opened such that the output lines of pumps 1351, 1353 are both in fluidic communication with pressure transducer 1386. While one of the pumps, for example, pump 1353, is run at a constant speed, the speed of the other pump, for example, pump 1351, is regulated by the controller 1370 responsive to signals from the pressure transducer such that there is zero pressure difference between the output lines of the pumps. In other words, the pump speed of one pump is synchronized with the pump speed of the other pump by the controller such that the pressure transducer 1386 achieves a zero pressure reading with valves 1382 and 1384 in the open state. With a zero pressure difference between the output lines, the flow rates through the output lines (and thus through the respective pumps) are substantially identical. Thus, valves 1382 and 1384 can be closed, and the system connected to a patient for performing a desired treatment.

[0123] Alternatively, the controller 1370 can be used to synchronize the pump such that a non-zero pressure difference exists between the output lines of the pumps 1351, 1353. For example, while pump 1353 runs at a constant first speed, the speed of pump 1351 can be adjusted by controller 1370 responsive to signals from the pressure transducer to a second speed at which the pressure difference between the output lines attains a desired non-zero value. The second pump speed of pump 1351 can then be correlated (e.g., synchronized) with the first pump speed of pump 1353 for performing a treatment on a patient. Such non-zero pressure synchronization may be beneficial for some pumps, such as peristaltic pumps, in certain pressure ranges.

[0124] Referring to FIG. 33, pressure differential across the double pump 1335 (pump head) may be controlled by a controller. In FIG. 33, two additional mechanisms are illustrated for controlling the pumping head of the double pump

1335. In a first, a variable throttling valve 1354 is controlled by a controller 1369 responsively to one or more pressure sensors exemplified by pressure sensors 1358 and 1356 located upstream of the double pump 1335. The variable throttling valve 1354 may vary the pump head of the double pump 1335 on the filter waste side such that a desired parity with the head across the replacement fluid side is achieved. Note that pressure sensors may be used downstream of the double pump 1335 alternatively, or in addition to, the pressure sensors 1358 and 1356 to determine pressure head. Also, differential pressure transducers may be used with upstream and downstream taps. Moreover, a variable throttling valve may be used downstream of the double pump 1335 rather than upstream. The throttling may be done on the replacement fluid side alternatively or in addition to throttling on the waste fluid side as illustrated.

[0125] Illustrated on the replacement fluid side is a linear actuator 1362 which is controlled to raise and lower a drip tank 1365. Fluid from the replacement fluid source 1342 is supplied to the drip tank 1365 and the height of the fluid column can be varied by the linear actuator 1362 by raising and lowering the drip tank 1365. As a result, the controller 1369 is able to vary the inlet pressure sensed at the pressure sensor 1356. By controlling the pressure of one side of the double pump 1335, it may be possible to provide a desired pressure head across the double pump 1335 to ensure that both the replacement fluid side and waste fluid side are substantially equal or such that they differ by an amount that ensures the total fluid balance during a treatment is at a desired level, for example, such that the volume of replacement fluid added to the patient is equal to the volume of waste fluid removed.

[0126] Referring now to FIG. 34, a mass-balancing system 1707 for maintaining patient fluid balance is illustrated. Here, waste flows into a waste bag 1741 through an inlet tube 1746. Access to the inlet tube 1746 may be controlled by a valve 1721. An outlet tube 1756 may be used to release the contents of the waste bag 1741 via a valve 1723. Replacement fluid flows into a replacement fluid bag 1741 through an inlet tube 1747. Access to the inlet tube 1747 may be controlled by a valve 1722. An outlet tube 1757 may be used to release the contents of the replacement fluid bag 1742 via a valve 1724. The total mass of the bags 1741 and 1742 and their contents is indicated by a scale 1705 and hung from a fixed hanger 1700.

[0127] At the start of treatment, the control valve 1723 may be opened and the control valve 1721 closed to permit the emptying of the waste fluid bag 1741. Also, the control valve 1722 may be opened and the control valve 1724 closed to permit the filling of the replacement fluid bag 1741 with replacement fluid. Prior to treatment, a reading from the scale 1705 may be obtained and stored by a controller (not shown separately). The controller may then control the control valves 1721, 1722, 1723, and 1724 as well as any pumps employed, depending on the particular design of the treatment system, to fill the waste fluid bag 1741 with waste fluid and move replacement fluid out of the replacement fluid bag 1742 at such rate as will maintain a constant value of the mass indicated by the scale 1705. The bags 1741 and 1742 may be large enough to accommodate that waste and replacement fluid loads for an entire treatment.

[0128] Alternatively, the control valves 1721, 1722, 1723, and 1724 (and any pumps required—not shown) may be actuated to periodically empty the waste fluid bag 1741 and

refill the replacement fluid bag 1742 to perform a cyclic balancing similar to that described with reference to FIG. 29. That is, after a certain interval measured by elapsed time, cumulative flow of replacement or waste fluid indicated by the integrated signal of one or more flow sensors, rotations of the rotor of a replacement fluid or waste fluid pump, etc. the waste fluid bag 1741 may be emptied by actuation of the control valves 1721 and 1723 and the replacement fluid bag 1742 re-filled by actuation of the control valves 1722 and 1724. During such a reset operation, the treatment may be halted to stop the flow of waste fluid from a filter or dialyzer. Alternatively, a buffer vessel may be provided and used to allow the system of FIG. 34 to reset itself while waste fluid continues to collect in the buffer vessel. Once reset, the waste fluid bag 1741 would fill with the contents of the buffer vessel.

[0129] Note that although many of the above embodiments are described in terms of identical rates of replacement fluid addition and waste fluid removal, it is recognized that during most treatments a certain net addition or removal of waste fluid may be required (ultrafiltrate). Thus, it is contemplated in all of the contexts described that a net fluid addition or removal may be accomplished by various means, such as adding a certain amount of fluid at a point during treatment and otherwise maintaining equal rates of fluid removal and addition. Alternatively, the rates may be biased to favor replacement fluid addition or fluid removal according to the indicated requirements for a treatment. For example, referring to FIG. 1, level sensor 164A may indicate by magnitude of a signal level the height of the top of the container 160. This signal level may be biased to allow a desired amount of over-filling or under-filling to occur, which may result in a net extraction of fluid. In the embodiment of FIG. 7, the level of the tube 652 may be altered to favor net extraction or net addition of fluid. The pressure signal of a pressure-based control mechanism, for example that of FIG. 3, may be biased also to provide for net addition or extraction of fluid. Various mechanisms may be provided to allow for net addition or extraction as required and in no instance is it suggested that net extraction or addition is required to be zero, even though the embodiments above may be discussed in the context of zero net fluid addition/extraction by way of example.

[0130] It will be clear to one of skill in the art that the balancing systems described are as applicable to hemodialysis, hemodiafiltration, and other blood treatment systems as they are to hemofiltration, which is the particular embodiment emphasized in the detailed description. To be clear, in a dialysis system, the flow of dialysate is across one side of a filter membrane and the inflow of dialysate and outflow of dialysate are the flows that are balanced by the balancing mechanism. Thus, in the embodiments above, and in the claims, where the term “waste” is used, it should be clear that this may refer to the “spent” dialysate as much as fluid filtered out of the blood as in a hemofiltration system. Correspondingly, it should also be clear that the term “replacement fluid” may be understood to refer, depending on the embodiment, to fresh dialysate as well as a fluid infusate, as would be employed in a pure hemofiltration system. Also, perfect balance is usually not the goal in a treatment, as is known by those skilled in the art. The goal during treatment usually includes a net reduction and sometimes a net addition of fluid to a patient. Various mechanisms for providing this, for example with metered bypass flows of waste or replacement fluid to bias the balancing system or such are well-known.

[0131] One of ordinary skill in the art will recognize from the disclosure herein a number of permutations and alterations to the exemplary embodiments. Therefore, the invention is not limited by the particular embodiments disclosed.

1-20. (canceled)

21. A waste balancing system for an extracorporeal blood treatment system, the waste balancing system including:

- a container;
- a flexible replacement fluid receptacle disposed in the container, the replacement fluid receptacle having an outlet connected to a replacement fluid line that is configured to convey replacement fluid to a patient during a blood treatment performed by the extracorporeal blood treatment system;
- a flexible waste fluid receptacle disposed in the container atop the replacement fluid receptacle such that the waste fluid receptacle exerts a pressure on the replacement fluid receptacle based on the weight of waste fluid contained in the waste fluid receptacle; and
- a pressure element in contact with the replacement fluid line proximal to said outlet,

wherein the pressure element is configured to apply a pressure to the replacement fluid line such that when a combined height of the replacement fluid and waste fluid receptacles exceeds a predetermined threshold, replacement fluid is allowed to flow through the replacement fluid line, and

when the combined height of the replacement fluid and waste fluid receptacles is less than a predetermined threshold, the pressure element clamps the replacement fluid line to prevent flow therethrough.

22. The waste balancing system of claim 21, further comprising a waste fluid line connected to the waste fluid receptacle, the waste fluid line being configured to convey waste fluid generated by the blood treatment performed by the extracorporeal blood treatment system.

23. The waste balancing system of claim 21, wherein the pressure element includes a pressure body in contact with a surface of the replacement fluid line, which is a flexible conduit.

24. The waste balancing system of claim 23, wherein the pressure element further includes a pressure bag and a pressure conduit fluidically connecting the pressure bag with the pressure body, the pressure bag being filled with a fluid, and a height of the pressure bag determines the pressure applied to the replacement fluid line by the pressure body.

25. The waste balancing system of claim 23, wherein the pressure element further includes a pressure bag and a pressure conduit fluidically connecting the pressure bag with the pressure body, the pressure bag being filled with a fluid, and an amount of the fluid determines the pressure applied to the replacement fluid line by the pressure body.

26. The waste balancing system of claim 21, wherein the replacement fluid receptacle and the flexible waste receptacle each comprise a flexible bag.

27. A method of waste balancing in an extracorporeal blood treatment, the method comprising:

- inserting a sealed flexible bag of replacement fluid into a balancing container;
- connecting an outlet of the replacement fluid bag to a replacement fluid line, which is configured to convey replacement fluid to a patient during the blood treatment;

applying a first pressure to the replacement fluid line using a pressure element in contact with the replacement fluid line at a location proximal to said outlet;

gradually reducing the pressure applied by said pressure element until flow through the replacement fluid line initiates at a second pressure;

providing a flexible bag for waste fluid atop the replacement fluid bag in the balancing container; and

while maintaining the second pressure on the replacement fluid line by the pressure element, flowing waste fluid into the waste fluid bag, the flow of replacement fluid through the replacement fluid line being regulated by said second pressure.

28. The waste balancing method of claim **27**, wherein an amount of waste fluid flowing into the waste fluid bag is equivalent to an amount of replacement fluid flowing through the replacement fluid line.

29. The waste balancing method of claim **27**, wherein the replacement fluid line is a flexible contact and the pressure element includes:

a pressure body in contact with a surface of the replacement fluid line;

a pressure bag filled with a fluid; and

a pressure conduit fluidically connecting the pressure bag with the pressure body.

30. The waste balancing method of claim **29**, wherein the amount of pressure applied the pressure body to the replacement fluid line is determined by one of the height of the pressure bag and the amount of fluid in the pressure bag.

31. The waste balancing method of claim **30**, wherein the gradually reducing the pressure applied includes reducing the height of the pressure bag and/or reducing the amount of fluid in the pressure bag.

32. The waste balancing method of claim **30**, wherein the maintaining the second pressure on the replacement fluid line includes maintaining the height of the pressure bag and keeping the amount of fluid in the pressure bag constant.

* * * * *