



US 20090030284A1

(19) **United States**

(12) **Patent Application Publication**

Cole et al.

(10) **Pub. No.: US 2009/0030284 A1**

(43) **Pub. Date: Jan. 29, 2009**

(54) **OVERTUBE INTRODUCER FOR USE IN ENDOSCOPIC BARIATRIC SURGERY**

Related U.S. Application Data

(60) Provisional application No. 60/950,584, filed on Jul. 18, 2007.

(76) Inventors: **David Cole**, San Mateo, CA (US); **Melanie L. Harris**, Mountain View, CA (US); **Carlos E. Castro**, San Jose, CA (US); **Jason S. Stewart**, Redwood City, CA (US); **Samuel T. Crews**, Woodside, CA (US); **Daniel J. Balbierz**, Redwood City, CA (US)

Publication Classification

(51) **Int. Cl.**
A61B 1/32 (2006.01)
(52) **U.S. Cl.** **600/206**

(57) **ABSTRACT**

This application describes an overtube device that gives diagnostic and/or therapeutic access to body cavities using natural orifices of the body. The overtube includes an elongate flexible body having a distal portion deflectable in response to activation of a control cable. Proximal features of the overtube include an insufflations port and seals for minimizing loss of insufflations pressure around the shafts of instruments passed through the tube. In some embodiments, retractor elements are including on the distal portion of the overtube.

Correspondence Address:
STALLMAN & POLLOCK LLP
353 SACRAMENTO STREET, SUITE 2200
SAN FRANCISCO, CA 94111 (US)

(21) Appl. No.: **12/175,274**

(22) Filed: **Jul. 17, 2008**

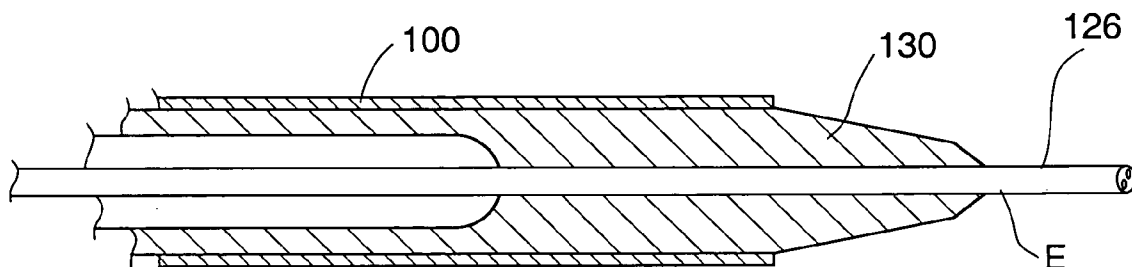

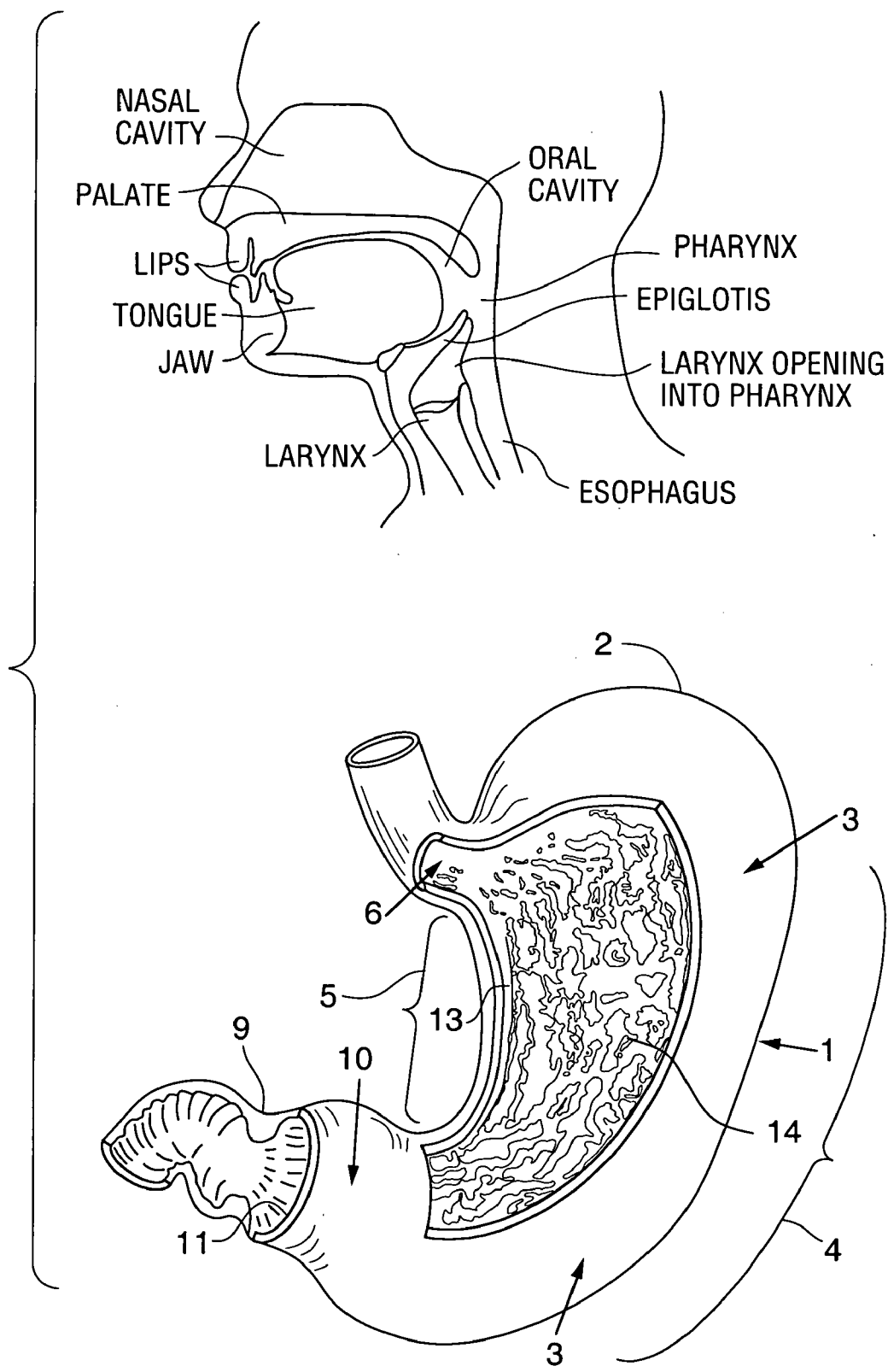

FIG. 1

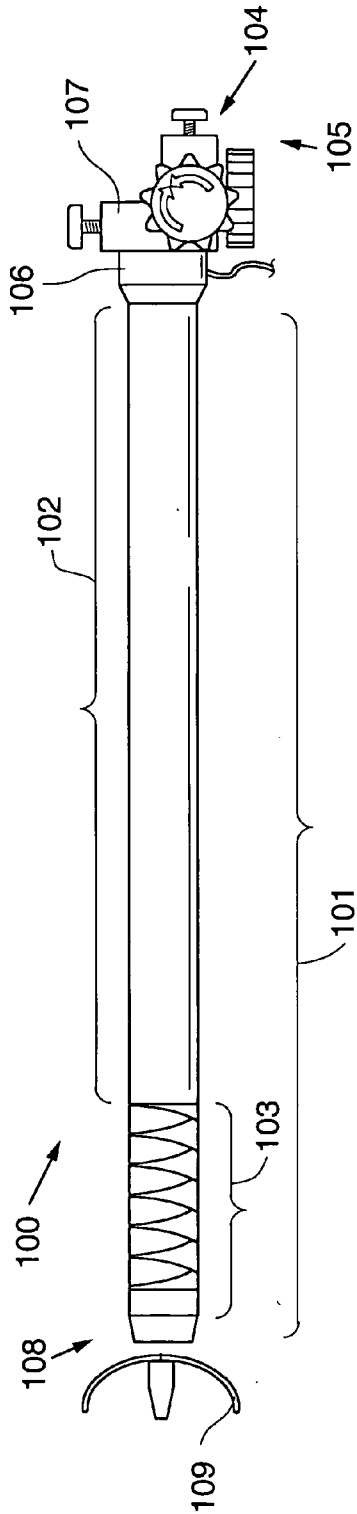

FIG. 2

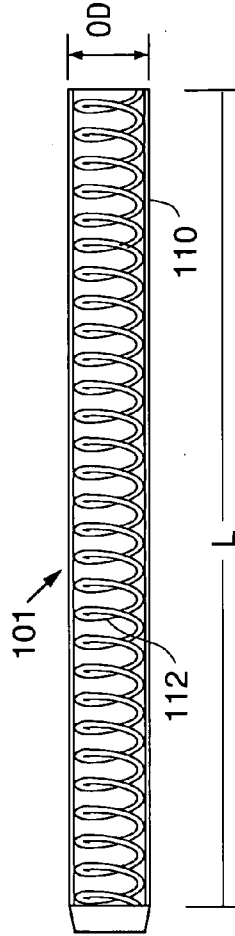

FIG. 3

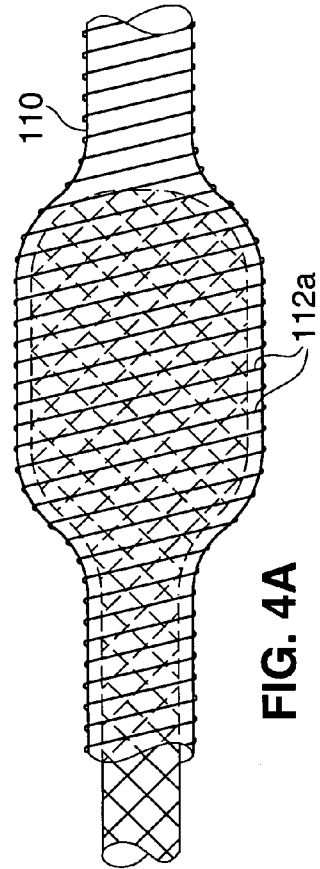

FIG. 4A

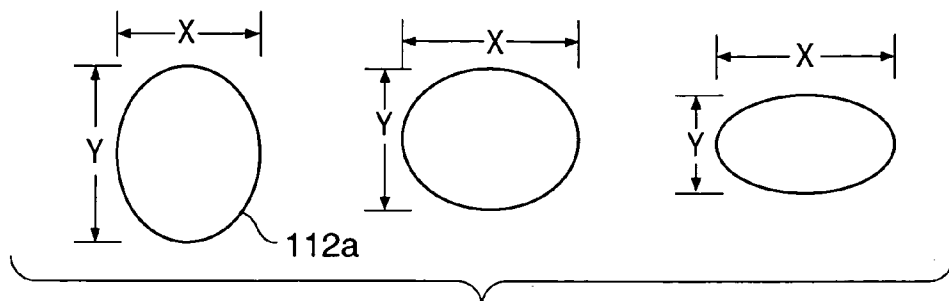

FIG. 4B

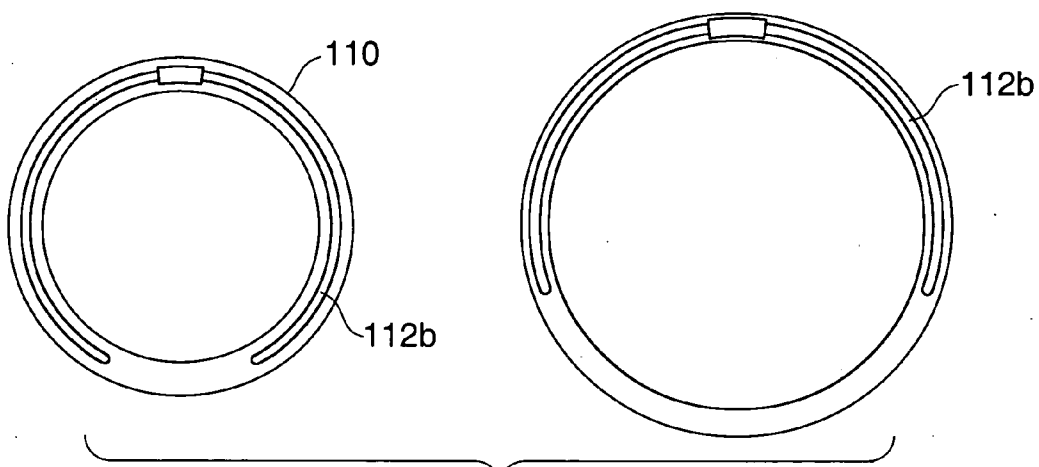

FIG. 4C

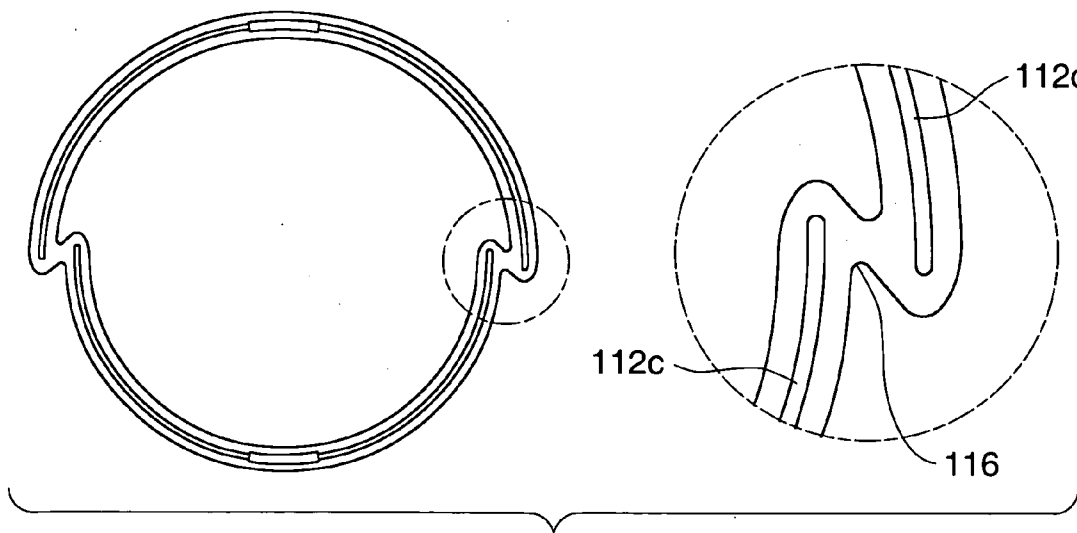
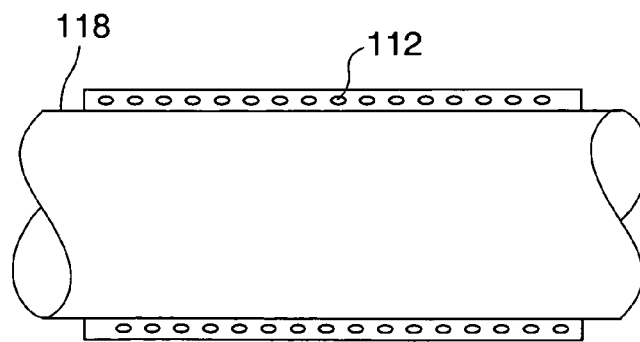
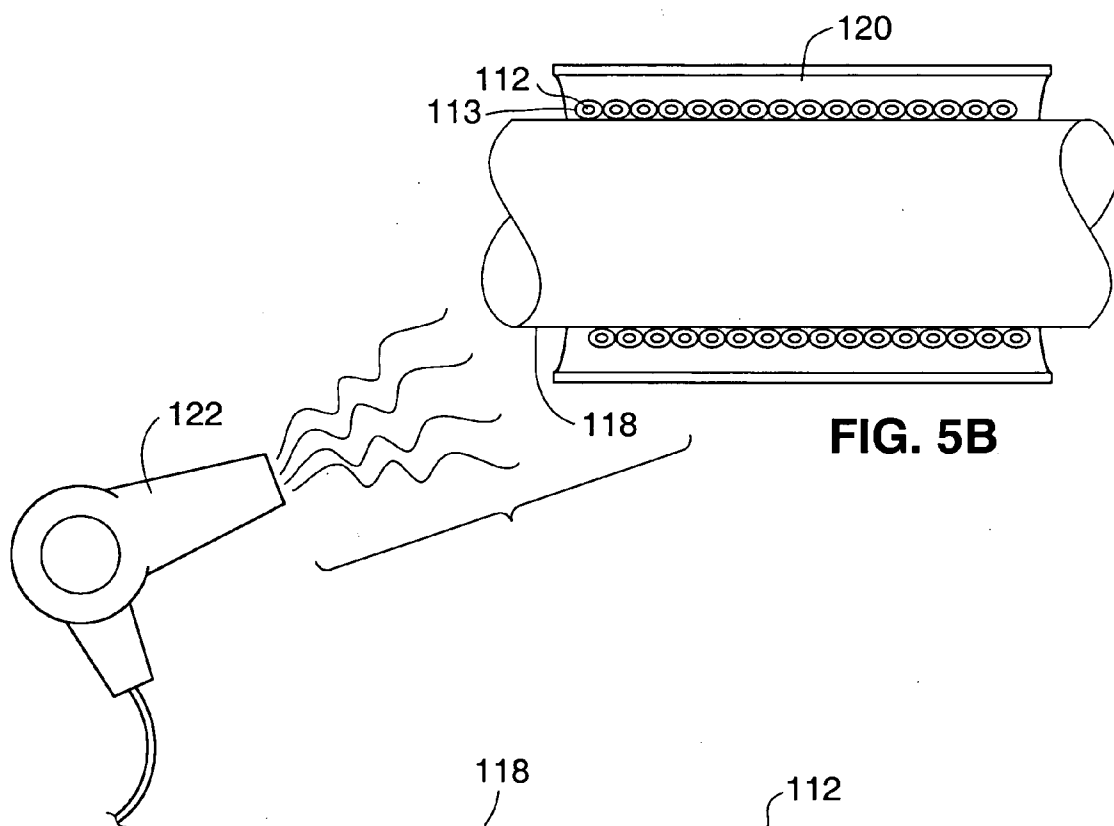
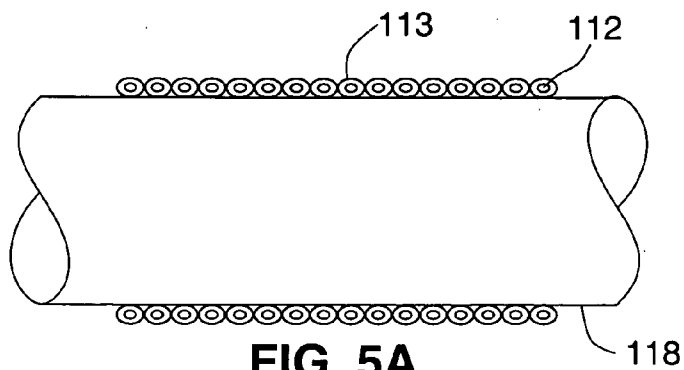

FIG. 4D



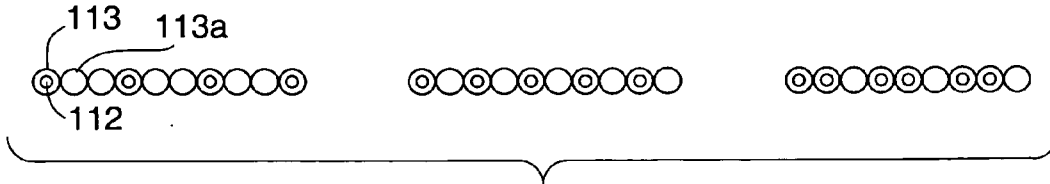

FIG. 6A

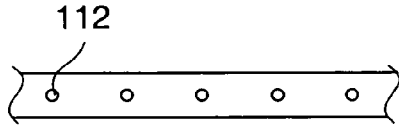

FIG. 6B

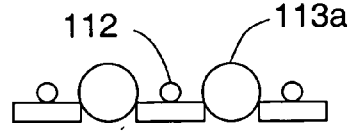

FIG. 6C

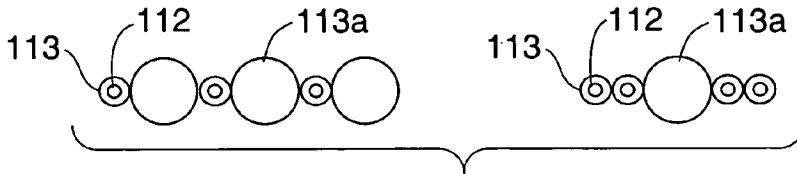

FIG. 6D

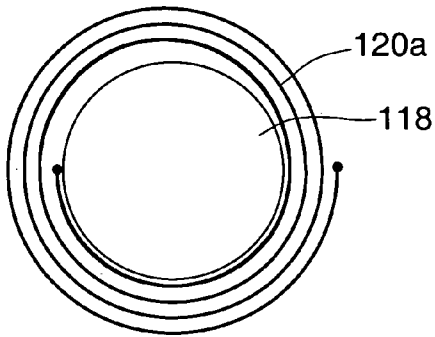

FIG. 7

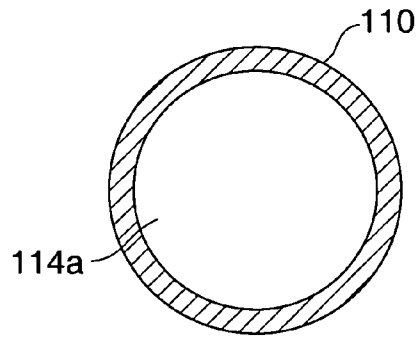

FIG. 7A

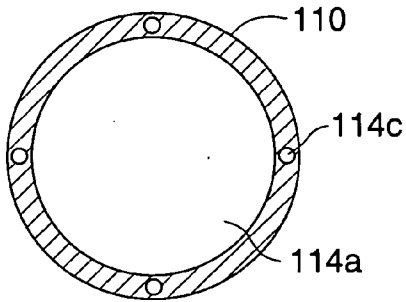

FIG. 7B

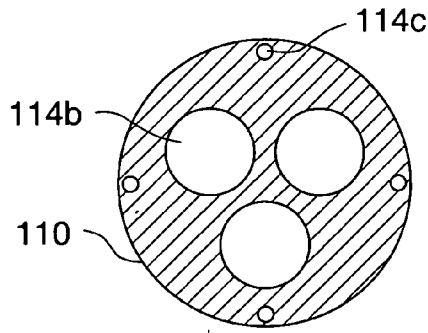

FIG. 7C

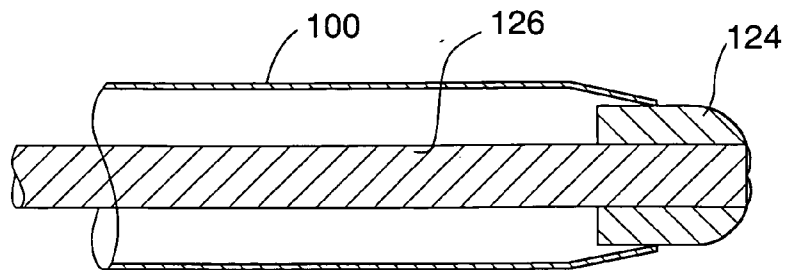

FIG. 8

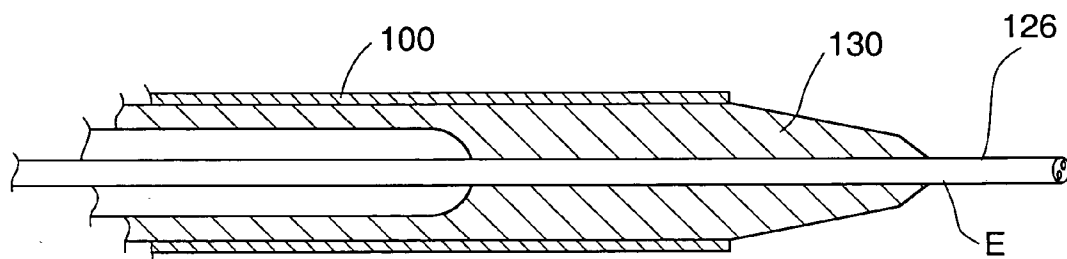

FIG. 8A

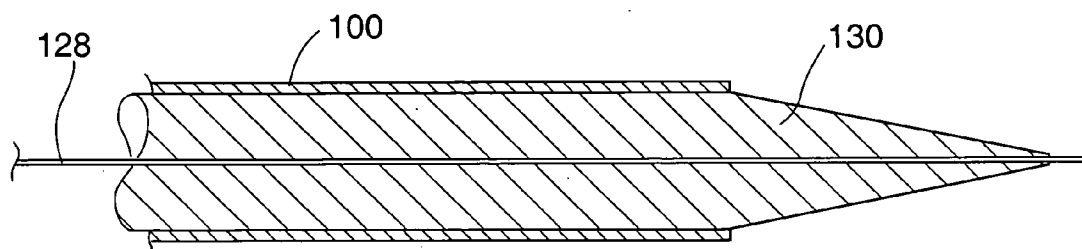

FIG. 8B

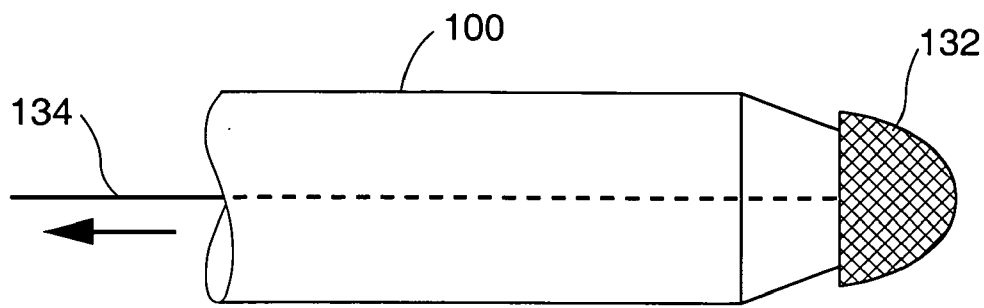

FIG. 9A

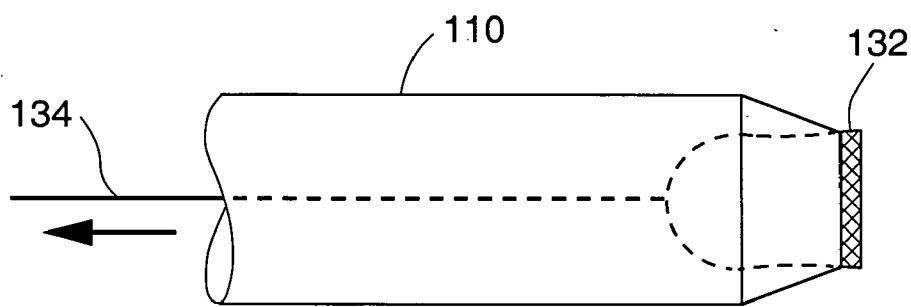

FIG. 9B

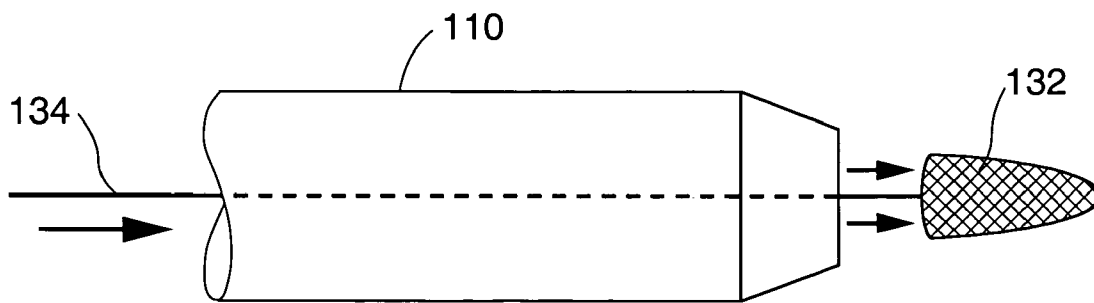

FIG. 9C

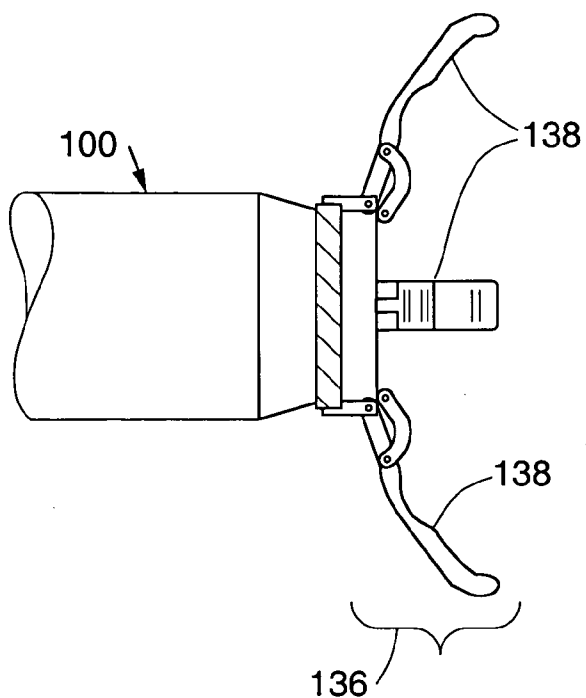

FIG. 10

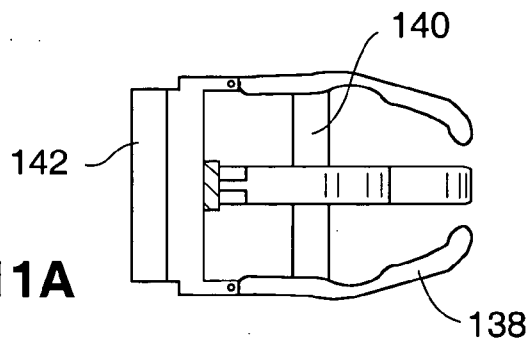

FIG. 11A

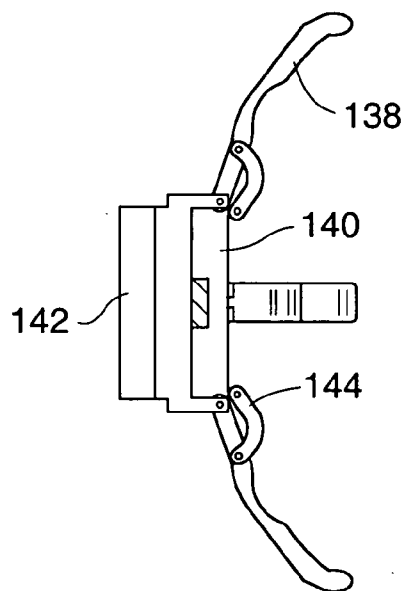

FIG. 11B

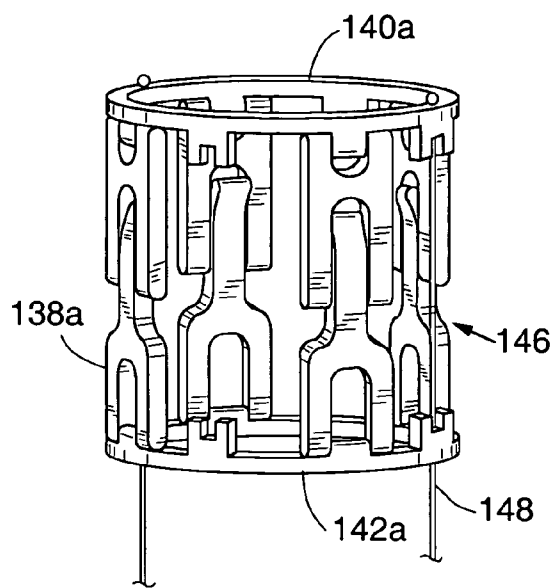

FIG. 12A

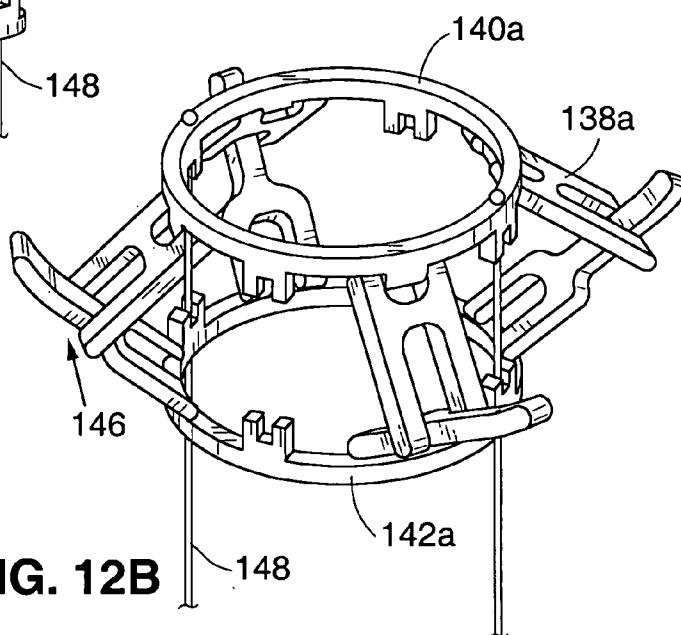

FIG. 12B

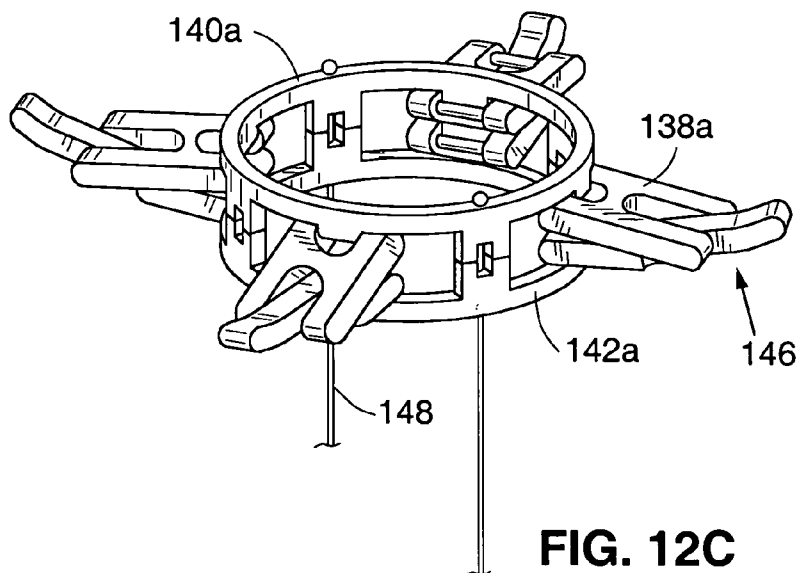

FIG. 12C

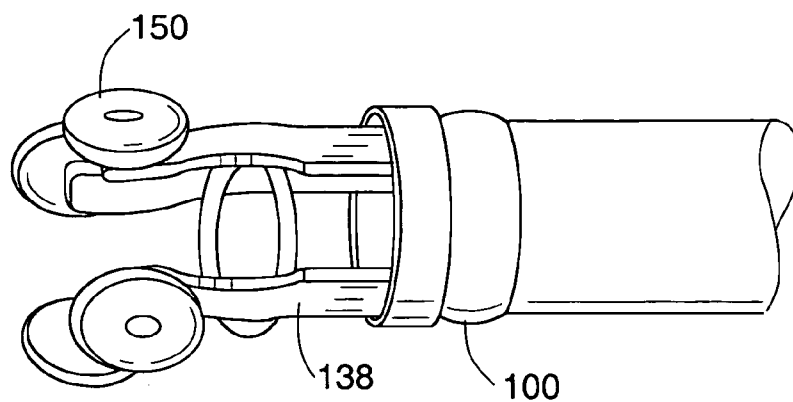

FIG. 13A

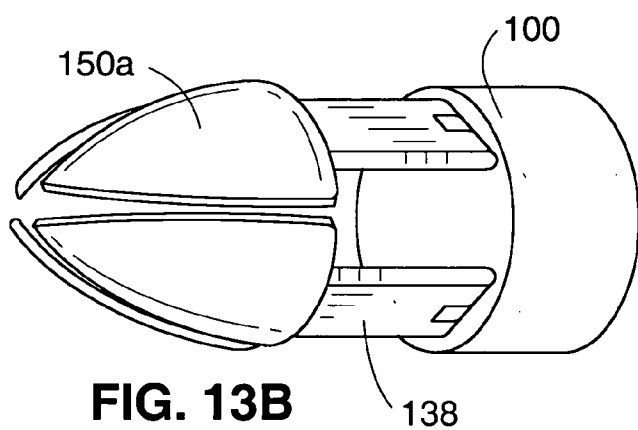

FIG. 13B

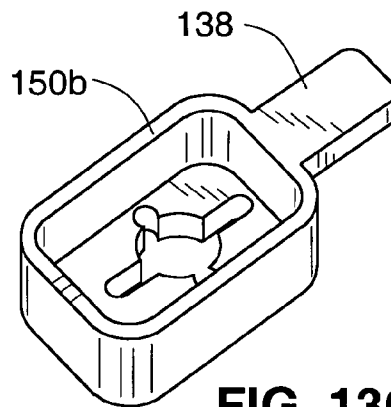

FIG. 13C

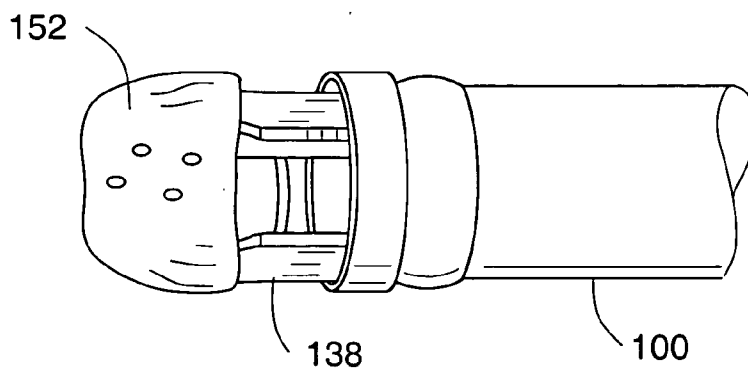

FIG. 13D

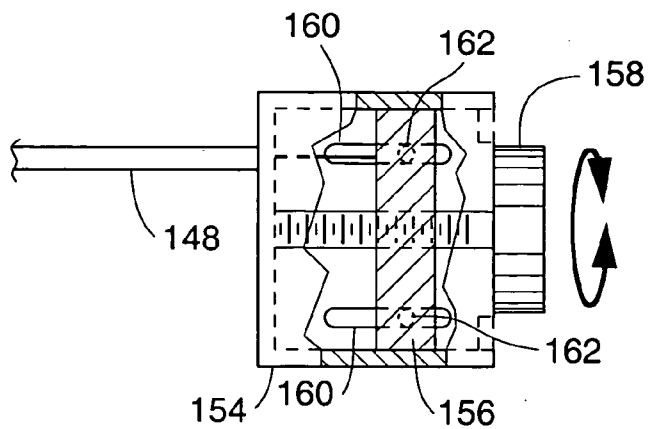

FIG. 14

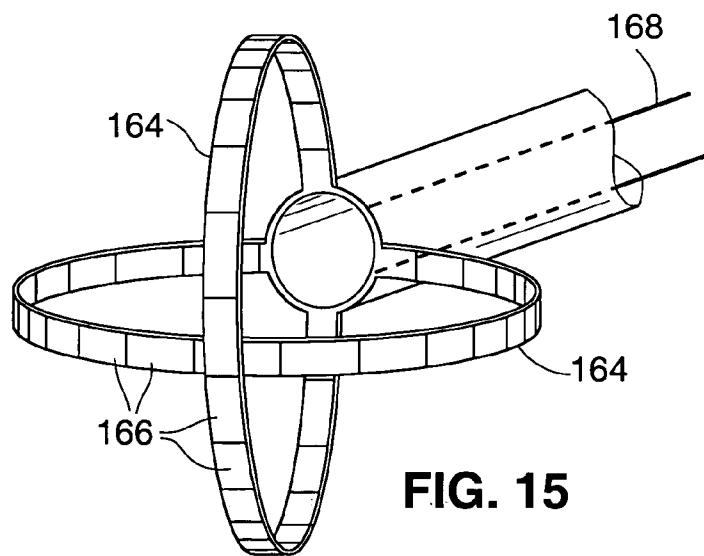

FIG. 15

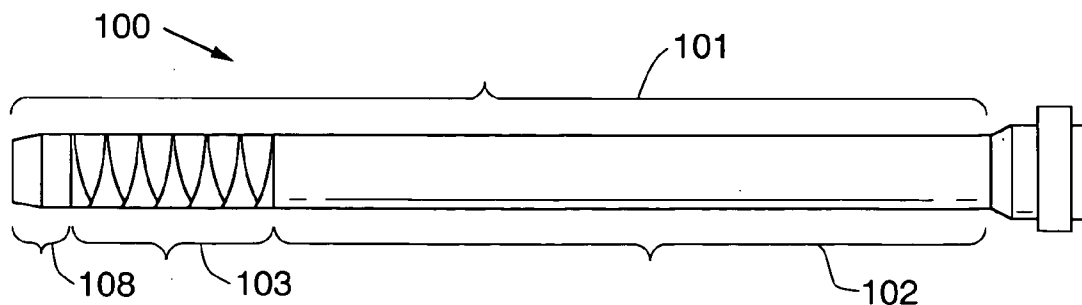

FIG. 16

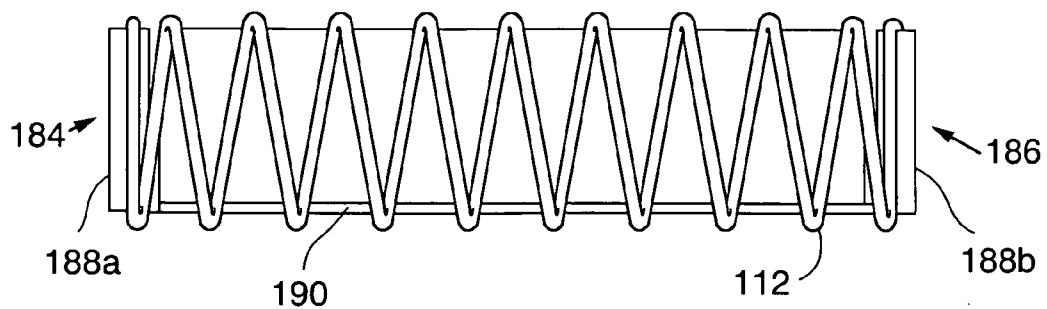

FIG. 17A

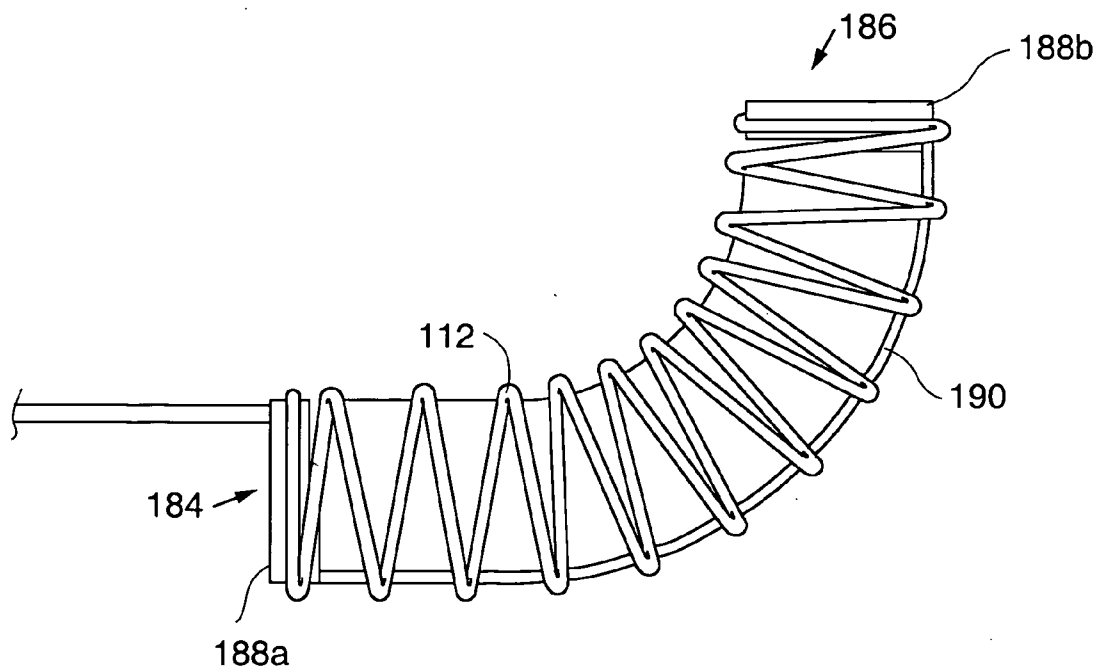

FIG. 17B

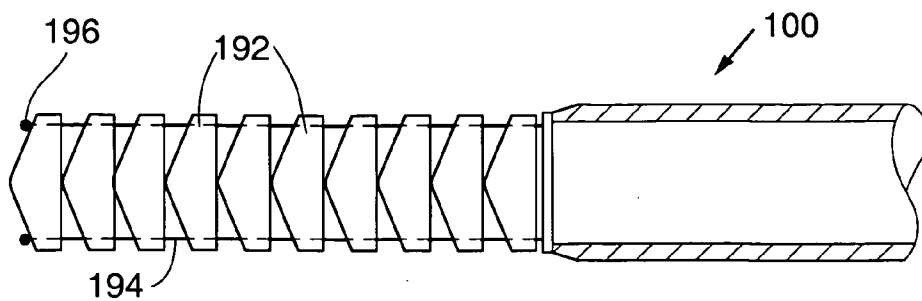

FIG. 18A

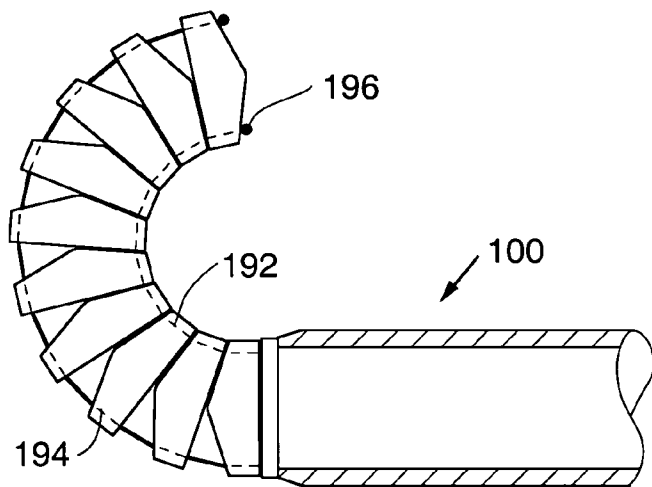

FIG. 18B

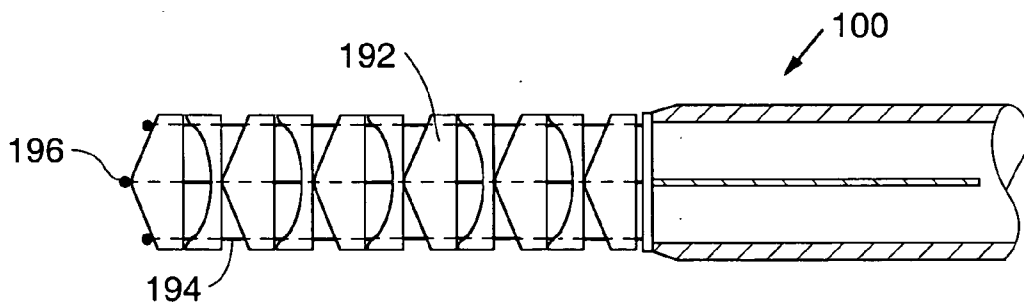

FIG. 18C

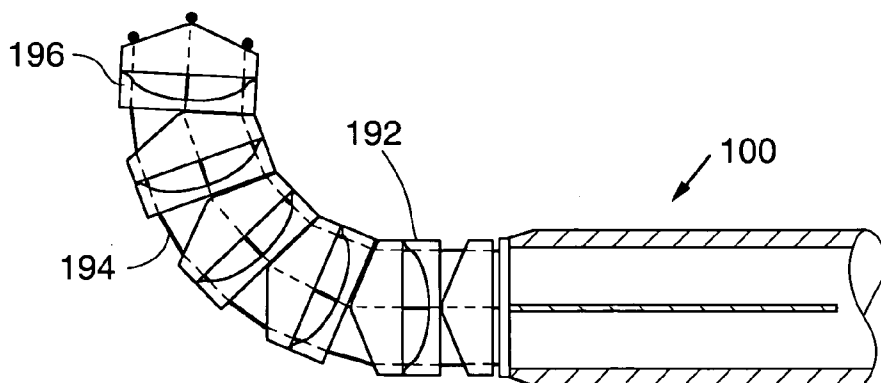
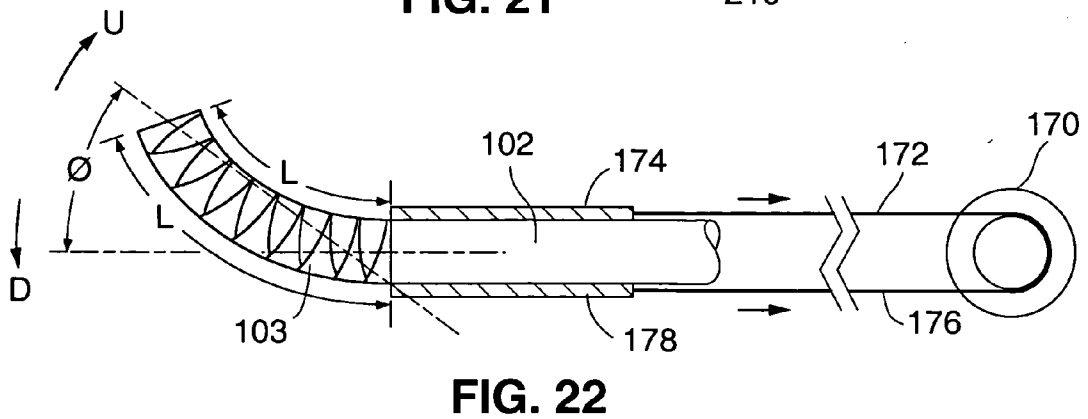
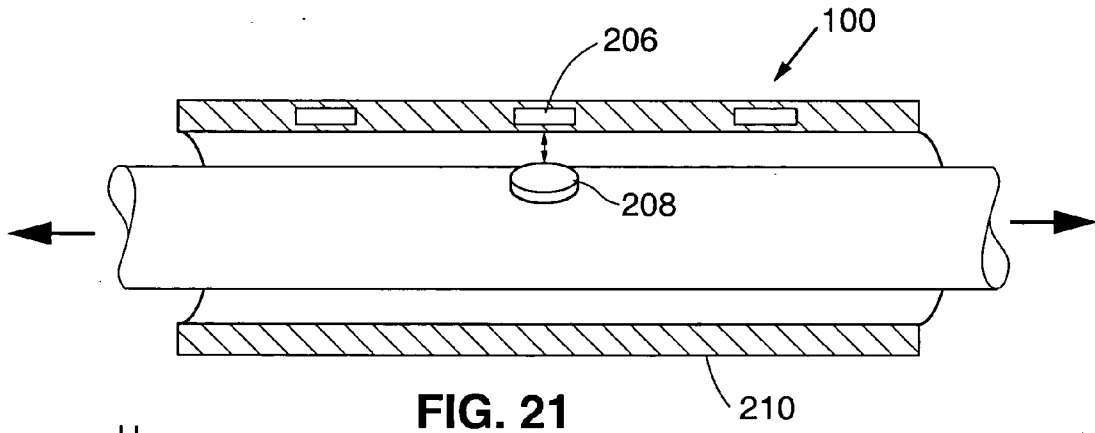
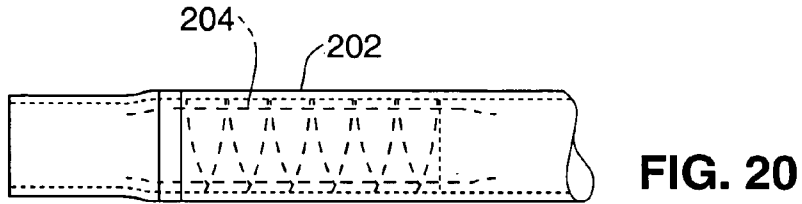
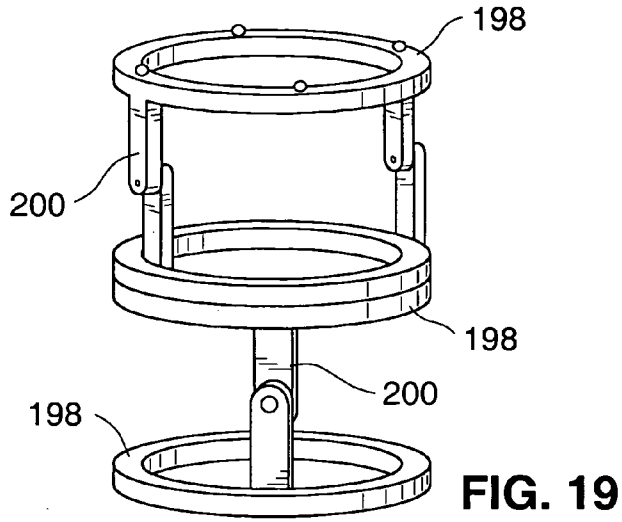

FIG. 18D



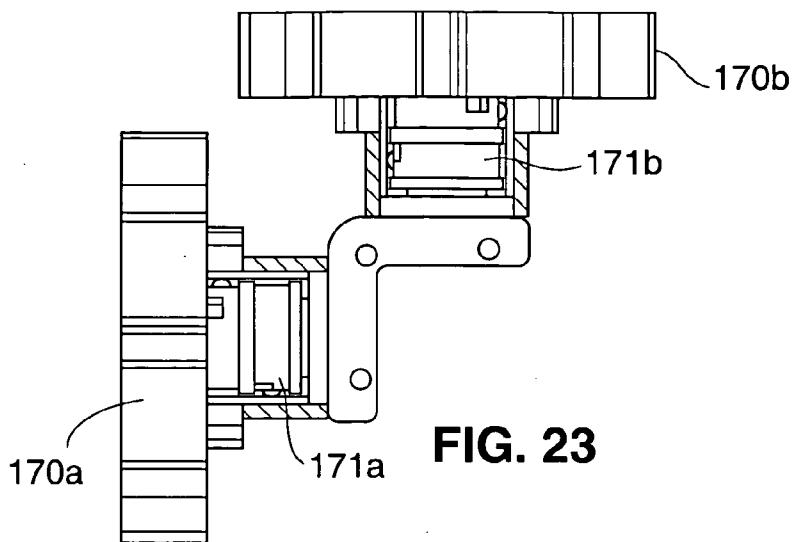

FIG. 23

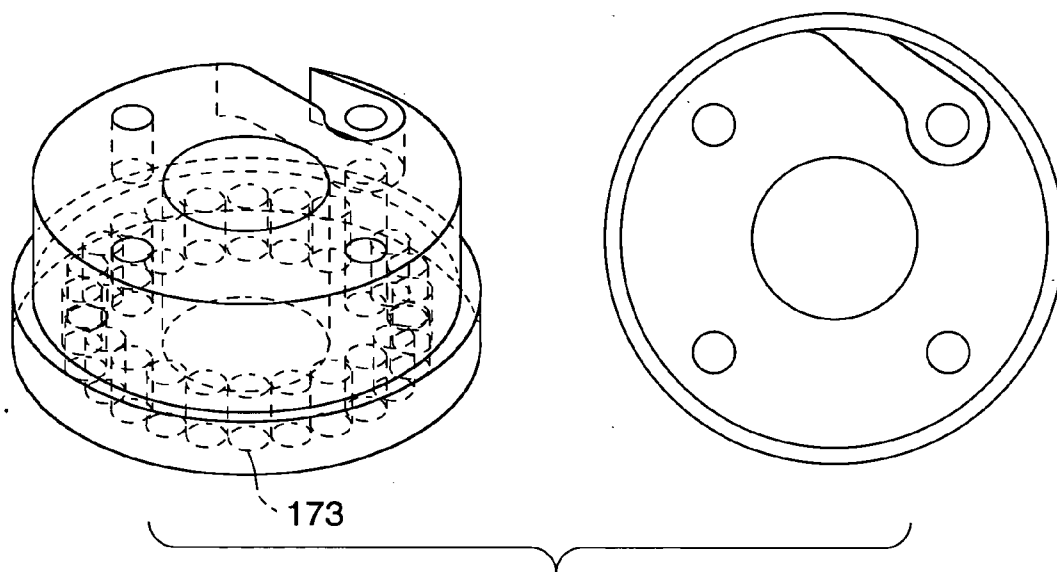

FIG. 24A

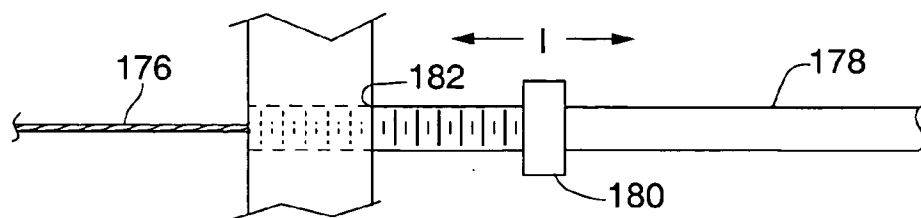

FIG. 24B

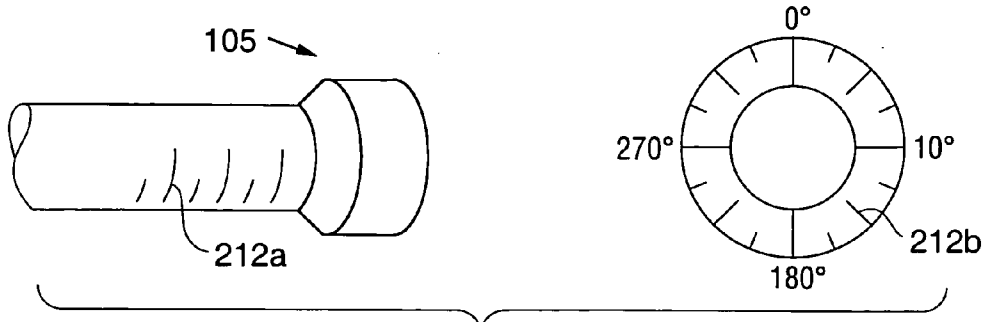

FIG. 25

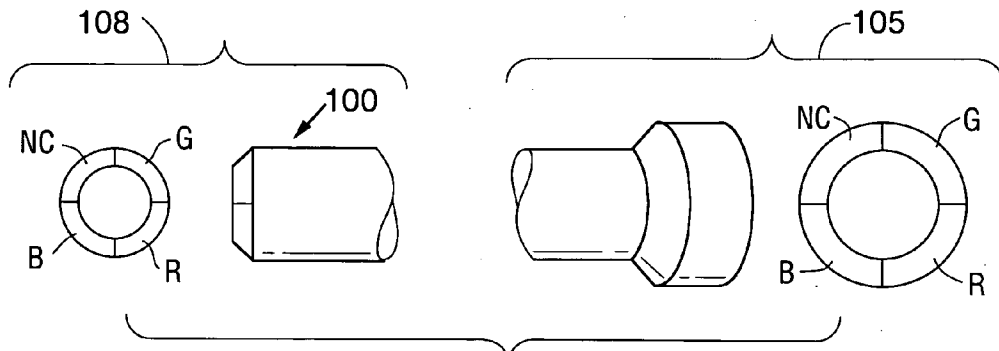

FIG. 26

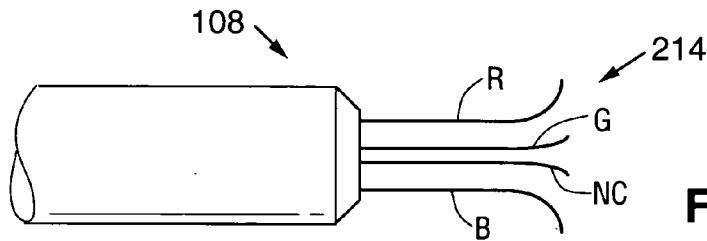

FIG. 27

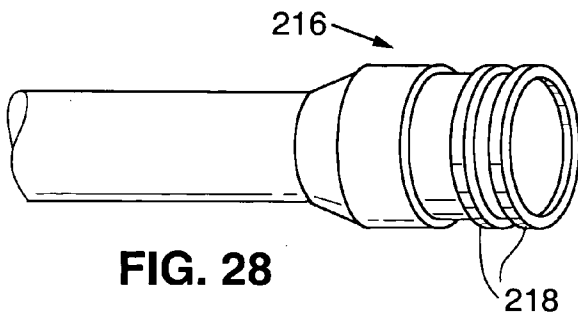

FIG. 28

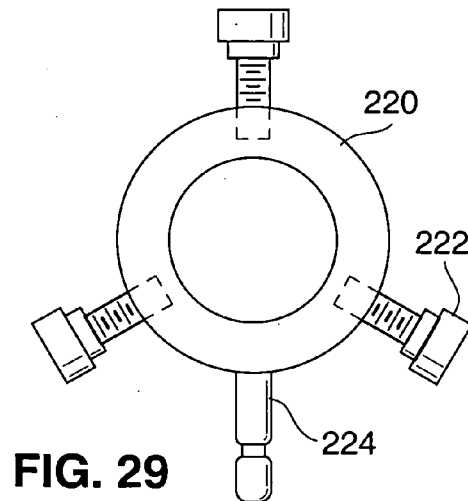

FIG. 29

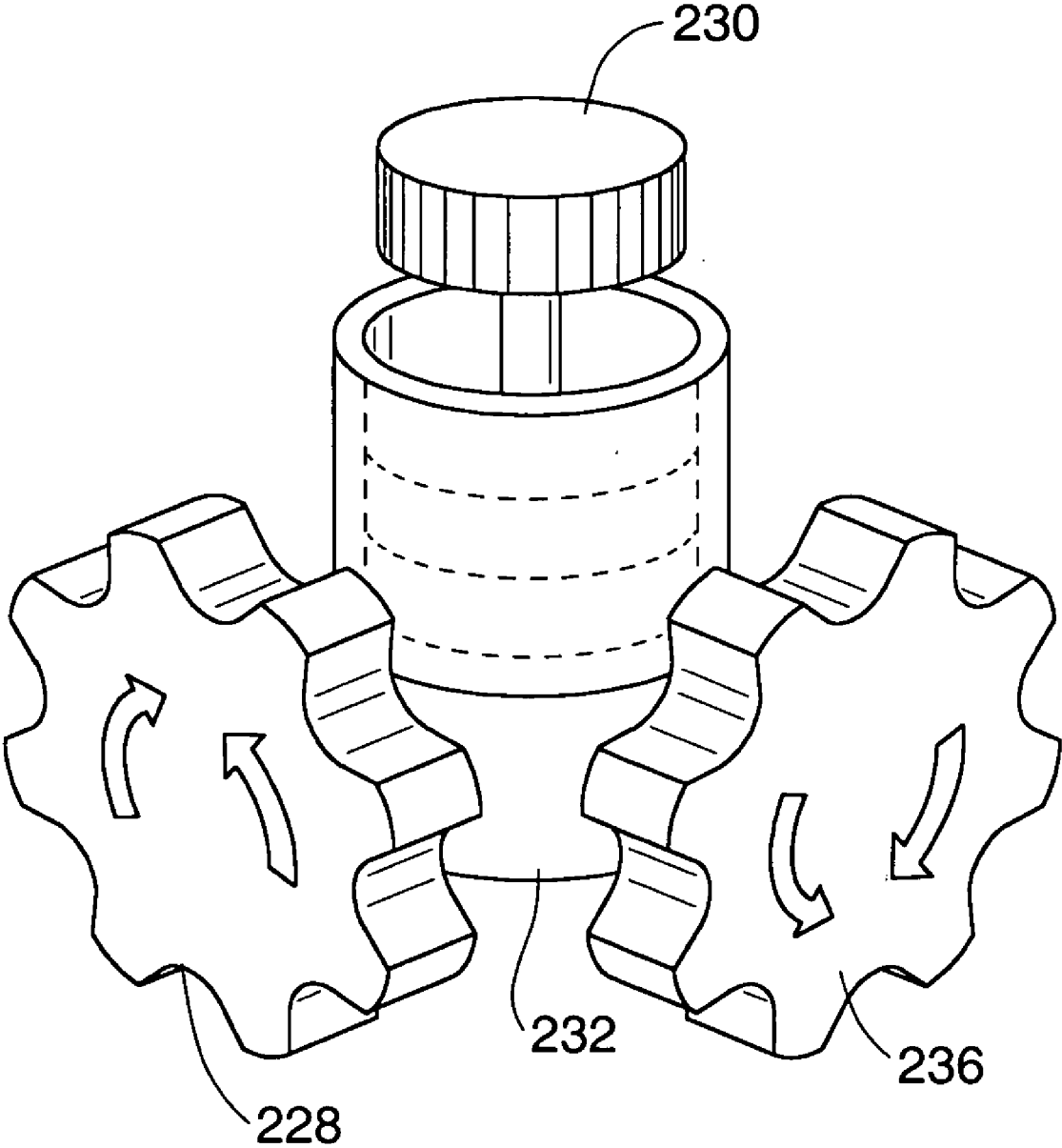

FIG. 30

**OVERTUBE INTRODUCER FOR USE IN
ENDOSCOPIC BARIATRIC SURGERY**

PRIORITY

[0001] This is application claims priority to U.S. Provisional Application No. 60/950,584, filed Jul. 18, 2007

BACKGROUND OF THE INVENTION

[0002] This application describes an overtube/introducer device that gives access to body cavities using natural orifices of the body (e.g., esophagus, anus, vagina) for a variety of therapeutic and/or diagnostic procedures. In a particular application, the overtube/introducer enables the introduction of devices into the gastrointestinal tract of a patient via the mouth and esophagus. Therapies to be carried out using the introducer can include procedures designed for the treatment of obesity. The disclosed overtube provides in and out access to the targeted procedural site and protects the body tissue during the procedure from trauma.

[0003] The disclosed overtube is suitable for use in an exemplary procedure in which the geometry of the stomach is modified and implantable devices are deployed. The procedure is preferably performed entirely through the naturally existing orifice of the mouth, without additional external incisions.

[0004] The exemplary procedure is initiated with the introduction of an overtube into the mouth and, at a minimum, past the pharynx of a patient but preferably reaching and sealing against the lower esophageal sphincter (LES). For reference, FIG. 1 shows the anatomy of the human head and stomach, with reference numerals identifying the following features:

- [0005] 1. Body of stomach
- [0006] 2. Fundus
- [0007] 3. Anterior wall
- [0008] 4. Greater curvature
- [0009] 5. Lesser curvature
- [0010] 6. Lower esophageal sphincter (LES)/gastroesophageal junction
- [0011] 9. Pyloric sphincter
- [0012] 10. Pyloric antrum
- [0013] 11. Pyloric canal
- [0014] 12. Angular notch
- [0015] 13. Gastric Canal
- [0016] 14. Rugal folds

[0017] The entire exemplary procedure is preferably performed under direct endoscopic visualization, obtained by inserting a flexible endoscope into the overtube prior to its introduction into the patient, though the procedure (or individual steps of the procedure) may also be performed without direct visualization. In cases where an endoscope is used, the endoscope's distal tip may be inserted into a flexible Bougie that incorporates a central lumen allowing direct line-of-sight for the endoscope's illumination and visualization optics. The endoscope with the installed Bougie may then be inserted into the overtube's central lumen until the Bougie protrudes just past the overtube's distal end. This provides a gentle leading edge that facilitates insertion of the Bougie, overtube and endoscope into the patient's esophagus.

[0018] Alternatively the overtube may be inserted over a guide wire; the guidewire inserted under direct visualization using a standard endoscope. A transition member is positioned between the inside diameter of the overtube and the outside diameter of the guidewire providing for a smooth

transition. This transition is preferably a long taper, and composed of a soft, flexible material such as silicone.

[0019] Once the overtube, endoscope and Bougie have reached the desired position within the esophagus, the endoscope and Bougie are withdrawn from the overtube, and the overtube is left in position. The overtube is now in a position to facilitate the introduction of other tools and devices needed to perform subsequent steps.

[0020] With the overtube in the desired position, a special-purpose stapler is inserted which will be used to prepare sites within the stomach wall tissue that will serve as mounting points for implantable devices to be installed in later steps. Staplers suitable for this procedure include those disclosed in the following U.S. Applications:

- [0021] U.S. application Ser. No. 11/542,457, filed Oct. 3, 2006, Attorney Docket BARO-1110;
- [0022] U.S. application Ser. No. 11/900,757, filed Sep. 13, 2007, Attorney Docket BARO-1310.
- [0023] U.S. application Ser. No. 12/119,329, filed May 12, 2008, Attorney Docket BARO-1610.
- [0024] U.S. application Ser. No. 12/050,169, filed Mar. 18, 2008, Attorney Docket BARO-1900.

[0025] In one such stapler, the leading distal tip of the stapler mechanism is covered with a compliant, bullet-shaped, Bougie end cap, and incorporates a side-looking window. The smooth Bougie shape of the end cap facilitates introduction of the stapler into the overtube and past the distal end of the overtube into the patient's esophagus or stomach. The side window allows stomach wall tissue to be drawn between the stapler jaws prior to the application of staples. The stapler incorporates a passive flexible length which allows the device to bend freely between the user controls at the proximal end and the stapler mechanism at the distal end. Insertion of the stapler is preferably performed under direct endoscopic visualization, with an endoscope positioned next to the stapler such that its camera optics are located slightly proximal of the stapler's distal end. In this way, the position of the stapler may be visualized at all times, relative to its position within the overtube, esophagus and stomach. However, insertion of the stapler may optionally be performed without using an endoscope for visualization.

[0026] With the stapler inserted into the stomach, it may then be positioned relative to the stomach wall near the lower esophageal sphincter as desired. In order to achieve the desired position and visualization, it may be necessary to withdraw or further insert the overtube, or to manipulate certain features of the overtube, in such a way that it advantageously alters the geometry of the tissue and/or the overtube's relative position. When the position of the stapler is judged to be correct, suction is applied to draw stomach wall tissue into the stapler end cap's side-looking window. This positions the stomach wall tissue between the jaws of the stapler, which are then approximated via a physician-controlled actuator to clamp the tissue firmly in position. Once the tissue has been securely fixtured, the suction may be released, as it is no longer needed to retain the stomach tissue. Staples are then deployed by means of a second physician-controlled actuator through the plication, or fold, of stomach tissue between the stapler's jaws to create circular rings about a central point. A hole is created in the plication of stomach tissue at the center of the pattern of staples simultaneous to the application of the staples. The hole and surrounding circular array of staples create a secure and durable mounting point (e.g., for implantable devices), and will be used in later steps

of the procedure. Once the staples have been deployed and the mounting point has been created, the physician releases the plication from the stapler's jaws and any remaining suction. The stapler and endoscope are then withdrawn from the overtube.

[0027] For staplers that must be re-loaded prior to the creation of the next mounting point, the stapler is withdrawn from the overtube and the distal stapling mechanism is then reloaded. For self-reloading stapler mechanisms, this step is not required. If reloading is required and has been performed, the reloaded device, Bougie end cap and endoscope are reinserted into the overtube. The process of positioning the stapler mechanism within the stomach described above is repeated so that the next mounting point is identified and created. This process is repeated to produce one or more anchor points, but preferably four mounting points are created. These mounting points may be anywhere within the stomach, but they are preferably located at the 3, 6, 9 and 12 o'clock positions, a fixed distance away from the lower esophageal sphincter. If the mounting points are to be used as anchor points for a flow restrictor of the type used to restrict/obstruct passage of food from the esophagus into the stomach, the preferential distance of the mounting points is such that the position of the exit of a restrictor attached at the mounting points will be immediately adjacent the lower esophageal sphincter. Exemplary restrictor devices include but are not limited to those disclosed in U.S. Pat. Nos. 6,675,809, 6,845,776, 7,097,665, and 7,146,984, U.S. application Ser. No. 10/345,666, filed Jan. 16, 2003, Attorney Docket No. BARO-300, and U.S. application Ser. No. _____, Endoscopic Implant System and Method, Attorney Docket BARO-2010, filed Jul. 17, 2008.

[0028] Once the desired mounting points have been created with the stapler, the stapler is withdrawn. Next, highly compliant anchors are installed through the hole at the center of each of the mounting points. The anchors have a rivet-like shape with large retaining heads on either end. The anchors are intended to be installed in the holes at the center of the mounting points, remain in position indefinitely or until removed, and be easily removable. The anchors are configured such that they may be grasped and pulled from one end (herein referred to as the "leading end"), and the resulting tension causes the leading end retaining head to change profile so that it may be drawn through the hole in a mounting point. The other end of the anchor (herein referred to as the "following end") is designed so that tension resulting from drawing it through the mounting hole does not result in a change to its profile, so it cannot be drawn through the mounting hole. Anchors of this type are described in U.S. application Ser. No. _____, Endoscopic Implant System and Method, Attorney Docket BARO-2010, filed Jul. 17, 2008.

[0029] Anchors are positioned in each of the mounting holes by means of graspers or similar instruments, which pull them, leading end first, through the mounting holes. Once the anchors are installed, the instruments required to insert them are withdrawn from the overtube.

[0030] Finally, a restrictor is inserted into the stomach via the overtube. The restrictor is attached to the anchors, and will remain in the stomach after the procedure for an indefinite period of time, such as the point in time when a physician determines the patient has achieved sufficient weight loss. The restrictor is attached to the anchors by drawing the leading end of the anchors through mounting holes in the restrictor using graspers or other instruments, as appropriate.

[0031] When the restrictor is attached to the anchors, the procedure is complete and the overtube may be withdrawn from the patient, along with any tools remaining in the lumen it defines (e.g., endoscope, graspers, etc.).

[0032] Upon completion of the procedure, the overtube has enabled the deployment of a restrictor, which is attached to anchors that have been implanted into stapled plications in the stomach wall. The passage of food into the stomach from the esophagus has been restricted, altering the patient's feelings of satiety and eating habits.

BRIEF DESCRIPTION OF THE DRAWINGS

[0033] FIG. 1 schematically illustrates certain aspects of the anatomy of the head and stomach;

[0034] FIG. 2 is a side elevation view of an embodiment of an overtube

[0035] FIG. 3 is a side elevation view of a distal portion of the overtube of FIG. 2.

[0036] FIG. 4A is a side elevation view of an alternate portion of an overtube, showing expansion of the distal portion in response to introduction of an instrument into the overtube.

[0037] FIG. 4B illustrates a reinforcing ring suitable for use in the deformable overtube of FIG. 4A and shows degrees of deformation of the reinforcement ring in response to instrument advancement through the overtube.

[0038] FIG. 4C is a cross-section view of the tube of FIG. 4A, shown as transparent to permit viewing of an alternate reinforcement. The figure shows deformation of the reinforcement ring in response to instrument advancement through the overtube. FIG. 4D is similar to FIG. 4C and shows yet another alternate reinforcement.

[0039] FIG. 5A-5C are a sequence of steps illustrating one embodiment of an overtube manufacturing technique

[0040] FIG. 6A shows three cross-section views of arrangements of alternating thermoplastic elements with and without wire cores that may be used to form a wall of an overtube in the method of FIGS. 5A-5C.

[0041] FIG. 6B is a longitudinal cross-section view of one embodiment of an overtube made using thermoplastic and wire core arrangements of the type shown in FIG. 6A.

[0042] FIGS. 6C and 6D is similar to the drawings of FIG. 6A but shows an alternate arrangement of thermoplastic elements and wire core elements.

[0043] FIG. 7 illustrates an alternate method of making an overtube using a thin sheet of thermopolymer or other suitable material.

[0044] FIGS. 7A-7B are cross-section views illustrating various lumen arrangements for the overtube.

[0045] FIG. 8 is a side elevation view of a distal portion of an overtube having a bougie positioned at its distal end.

[0046] FIG. 8A is a side elevation view of a distal portion of an overtube having a transition member and endoscope extending from its distal end.

[0047] FIG. 8B is a side elevation view of a distal portion of an overtube having a transition member and a guidewire endoscope extending from its distal end.

[0048] FIG. 9A is a side elevation view of a distal portion of an overtube having an umbrella-shaped leading element.

[0049] FIG. 9B is similar to FIG. 9A and illustrates inversion of the umbrella element for withdrawal.

[0050] FIG. 9C is similar to FIG. 9A and illustrates advancement and collapse of the umbrella element for withdrawal.

[0051] FIG. 10 is a side elevation view of a distal portion of an overtube having spreadable finger elements.

[0052] FIG. 11A is a side elevation view of a distal portion of a second embodiment of an overtube having spreadable finger elements, showing the finger elements in the retracted position.

[0053] FIG. 11B is similar to FIG. 11A and shows the finger elements in the expanded position.

[0054] FIG. 12A shows an alternative arrangement of finger elements which may be positioned on the distal end of an overtube as in FIG. 10.

[0055] FIG. 12B shows the finger elements of FIG. 12A in a partially expanded position.

[0056] FIG. 12C shows the finger elements of FIG. 12A in the fully expanded position.

[0057] FIGS. 13A and 13B are perspective views of the distal portion of an overtube showing alternative shapes finger elements at the distal end of an overtube.

[0058] FIG. 13C is a perspective view of a vacuum cup positioned on a finger element.

[0059] FIG. 13D is a perspective view of a distal portion of an overtube showing an implant device mounted to the finger elements.

[0060] FIG. 14 is a perspective view illustrating a control mechanism for use with expandable members such as the finger elements of FIGS. 10-13D.

[0061] FIG. 15 is a perspective view illustrating a distal portion of an overtube having an alternate arrangement of expandable elements in the form of a pair of expandable hoops.

[0062] FIG. 16 is a side elevation view of an embodiment of an overtube having an articulating distal portion.

[0063] FIG. 17A illustrates an embodiment of a spring assembly suitable for use in the overtube of FIG. 16.

[0064] FIG. 17B shows the spring assembly of FIG. 17A in an articulating position.

[0065] FIG. 18A is a side view of a distal portion of an overtube utilizing a stacked ring construction for the articulating section.

[0066] FIG. 18B is similar to FIG. 18A and shows the articulating section in an articulated position.

[0067] FIGS. 18C and 18D are similar to FIGS. 18A and 18B and show an alternate configuration of stacked ring elements.

[0068] FIG. 19 is a perspective view showing an alternate arrangement of ring elements suitable for use in the articulating section.

[0069] FIG. 20 is a side elevation view of a distal portion of an overtube illustrating optional inner and outer sheaths covering the articulating section.

[0070] FIG. 21 is a cross-sectional side view of an overtube with an instrument positioned in the lumen of the overtube, and illustrates the use of magnetic indexing.

[0071] FIG. 22 is a cross-sectional side elevation view showing a distal portion and intermediate portion of an overtube together with proximal control features for use in controlling the articulating section of the overtube.

[0072] FIG. 23 illustrates articulating control features utilizing separate spools for each pullwire cable.

[0073] FIG. 24A is a perspective view of a portion of a spool and knob having a selection of cable attachment points allowing for selection and/or adjustment of cable length.

[0074] FIG. 24B is a side elevation view showing a barrel adjuster suitable for fine tuning cable length.

[0075] FIG. 25 shows perspective view and proximal end views of an overtube having depth and angle markings.

[0076] FIG. 26 shows a distal end view, side elevation view, and proximal end view of an overtube and illustrates color coding of angle markings.

[0077] FIG. 27 is a side view of a distal portion of an overtube, illustrating the use of color coded markers positioned within the field of view of an endoscope used in combination with the overtube.

[0078] FIG. 28 is a perspective view of a proximal end of an overtube and illustrates a terminating end ring.

[0079] FIG. 29 is a plan view of a proximal end of an overtube and illustrates an iron intern ring.

[0080] FIG. 30 is a perspective view of a proximal portion of an overtube showing the use of steering controls and expandable element controls on iron an intern ring of the type shown in FIG. 29.

DETAILED DESCRIPTION

[0081] The present invention comprises an overtube intended to be inserted through the mouth into the esophagus of a patient, and extend at least past the pharynx, but preferably far enough for the distal end to seal against the lower esophageal sphincter (LES) at the junction between the stomach and the esophagus. The overtube incorporates features that enable it to facilitate the procedure described in the Background section above though is not restricted to that single procedure. The primary purpose of the present invention is to create and maintain a patent lumen that provides access from the mouth of a patient to the stomach. The outer diameter of the overtube's insertable length allows it to fit within, and be insertable into, a patient's gastrointestinal tract from the mouth to the stomach. The outer surface of the insertable length of the overtube is sufficiently lubricious to allow for its introduction into the esophagus and subsequent manipulations (e.g., further insertion or withdrawal, rotation), and/or is compatible with lubricants commonly used for such procedures. The inner diameter of the overtube's insertable length is sufficiently large to accommodate the insertion of the instruments described in the Background section (e.g., stapler, endoscope, graspers, etc.). Alternatively, the Overtube may be composed of multiple lumens allowing multiple tools to be inserted without interfering with each other. The inner surfaces of the overtube's insertable length are sufficiently lubricious to allow the insertion of instruments and devices, and/or are compatible with lubricants commonly used for such purposes. The overtube conforms to the patient's anatomy and protects anatomical features (e.g., the pharynx, esophagus, lower esophageal sphincter, etc.) from injury that may result from the insertion and manipulation of instruments during the procedure. Further, the overtube provides a means to control the position relative to the LES along the axis of insertion. The position of the distal end of the overtube may be controlled by means of insertion and withdrawal of the instrument (the "Z-level"), by means of rotation of (torquing) the insertable length of the overtube, and by optionally incorporating an articulatable, steerable, lockable section somewhere within the insertable length. The overtube assembly may also incorporate expandable elements at or near the distal tip that assist in creating a volume within the stomach, reshaping the walls to facilitate visualization and access. The overtube possesses sufficient tensile, compressive and hoop strength to resist excessive deformation (e.g., extension, compression, collapse, kinking) during use. Materials suitable for

short-term mucosal tissue contact are preferable for use in the overtube, e.g., stainless steel, nitinol, silicone, urethanes, PEEK, PVC, etc.

Overview and System Layout

[0082] FIG. 2 shows a general system diagram of the overtube **100**, and indicates the configuration and names of system components. The insertable length of the overtube **101** is comprised of at least one passive section **102** and optionally at least one articulatable, lockable section **103**, which may be steered by means of controls **104** at the proximal end **105** of the assembly. The proximal end also incorporates a terminating end piece **106** and an iron intern ring **107**, which serve to support and orient the device during use. At the distal end **108** of the overtube, spreadable fingers **108** may be incorporated to facilitate maneuvers during a procedure. The configuration of the spreadable fingers is determined by controls **104** at the proximal and **105**. The construction of the overtube may include some or all of these elements, in different combinations, or it may omit elements, depending on the configuration. This disclosure is intended to include all combinations of inclusion or exclusion of these elements.

Insertion Tube Characteristics

[0083] One embodiment of the present invention's insertable length **101** (FIG. 3) consists of a compliant, flexible, hollow tube. The preferred dimensions of the tube are approximately 38-42 cm (15-16.5 in.) in length (L), with outer diameter (OD) of approximately 1.0-2.0 cm (0.780 in.) (preferably 2.0 cm, but up to approximately 2.2 cm), inner diameter (ID) approximately 1.8 cm (0.700 in.) and wall thickness (T) approximately 0.1-0.2 cm. Larger diameters are preferable when the anatomy will accommodate it, however tubes having smaller dimensions (including those having a diameter proportioned to only accommodate small instruments or endoscopes) are also considered within the scope of this invention. The tube is supported internally at least part of its length by a springform wire **112**, intended to support the compliant material comprising the tube **110**, and to improve the tube's patency when bent, and to improve the tube's torsional rigidity to facilitate rotating the overtube when in situ during a procedure (its "torquability"). The springform wire reinforcement may extend the full length of the tube, or it may optionally terminate some distance short of the distal or proximal tip. The reinforcement **112** may be encapsulated within the overtube's wall in a thermopolymer or thermoset polymer matrix. The overtube is designed to be compliant and flexible, enabling it to follow the contours and navigate around features of the patient's anatomy, and is capable of conforming to curves with a radius of curvature of at least 1.5 in.

[0084] The tube **110** may also incorporate a thin woven mesh, encapsulated within the compliant material as described above, either in conjunction with the springform wire **112** or in lieu of such a wire. The woven mesh may be made of stainless steel, for instance, or aluminum, or any of a variety of polymeric materials. The purpose of embedding mesh within the tube is to substantially increase its torquability while having a minimal effect on its resistance to bending or its minimum radius of curvature.

[0085] The outer surface of the insertable length of the overtube should be sufficiently lubricious to allow for its introduction into the esophagus and subsequent manipula-

tions (further insertion or withdrawal, rotation), and/or be compatible with lubricants commonly used in such procedures. The inner surfaces of the overtube's insertable length should also be sufficiently lubricious to accommodate the insertion of instruments and devices, and/or be compatible with lubricants typically used in such applications. In order to achieve sufficient lubricity, inherently lubricious materials may be selected (e.g., PTFE), or coatings may be applied to base materials (e.g., hydrophilic or hydrophobic coatings). Features that prevent locking or binding between components may also be incorporated, such as serrations or surface features similar to those seen on knives designed for slicing meat. Such features facilitate sliding, rather than binding, when elements are moved relative to one another.

[0086] The tube **110** may include a single or large central lumen **114a** as shown in FIGS. 7A and 7B, or multiple smaller lumens **114b** as in FIG. 7C. Additionally, the tube may incorporate numerous channels **114c** completely or partially within the wall. (FIG. 7B). In this way, it comprises a multi-lumen tube, with at least one large central lumen whose primary purpose is facilitating the introduction of instruments and devices to the stomach, and at least one much smaller lumen, through which control cables, fluids, etc. may be routed between the proximal and distal end of the device, or to intermediate points between the ends. In this way, the device presents a single, smooth outer surface to the patient, rather than having any ancillary elements separate from the overtube's insertable section itself in contact with a patient's gastrointestinal tract tissue. This provides protection for the components that may be routed within these lumens, and increases control of cleanliness and thus device function, as well as reduction of requirements for biocompatibility. In some cases, the small channels or lumens **114c** within the wall of the overtube may serve more than one purpose: for example, the compressive housing of a Bowden cable may be unnecessary when the control cable is routed within one of the small lumens in the overtube itself, eliminating a component and simplifying the design. For reference, a Bowden cable is comprised of an inner control cable which is housed in an outer housing designed to withstand compressive loads, often a coil tube. Displacements at the proximal end of the inner cable relative to the coil tube housing of a Bowden cable are transmitted to the distal end of the inner cable, and can be used as an actuator to create useful forces and motion relative to the cable housing.

[0087] The construction of the overtube may also be such that it may be expanded as necessary after it has been placed within a patient's anatomy. In the event that large instruments or devices are to be inserted through the overtube into the stomach, it may be beneficial to allow the overtube to expand to accommodate such large components that may otherwise fit too tightly or not at all, and to then return to its unexpanded diameter following passage of the large device. This is illustrated in FIG. 4A. One means of accomplishing this is to form the reinforcing wire rings **112a** or coil used to support the overtube structure into elliptical shapes, rather than a circular profile. Such rings could also be encapsulated within a thermopolymer or thermoset polymer matrix, as described above. If the elliptical reinforcing rings are tilted in aspect ratio, as shown in FIG. 4B, the cross sectional shape of the overtube's insertable length is circular under normal circumstances. However, when a large instrument is inserted into the overtube's central lumen to the stomach, the elliptical reinforcing rings comprising the overtube's structural supports can

change aspect to present a larger cross sectional area, thus allowing the large instrument to pass through. FIG. 4C shows another embodiment, which relies upon support rings 112b which are not continuous closed forms, but rather are partial rings which have a shape resembling the letter "C". The shape of the partially ring can optionally be in a closed default configuration to resemble the letter "O", with the ends of the ring touching or overlapping, which then dilate and open a gap when expansion forces are applied. Alternatively, more than one wire shape 112c can be combined to create a structure which spans the full circumference of the tube (FIG. 4D). In cases where the ends of the wire endpoints overlap, a fold 116 may be introduced in the thermopolymer or thermoset polymer matrix encapsulating the support to facilitate such dilation (FIG. 4D).

[0088] One means of manufacturing the insertable length of the overtube assembly as described (with reinforcing elements encapsulated within a matrix) is to start with a wire 112 which is coated with a thermopolymer 113. This wire may be coiled around a mandrel 118 having the desired outer diameter or profile (the mandrel's outer diameter need not be consistent). This is depicted in FIG. 5A. Heat shrink 120 may then be placed over the entire wound wire and mandrel 118 and heat applied, for example with a heat gun 122 or hot box, causing the heat shrink to relax over the wire (FIG. 5B). With the appropriate amount of heat addition, the heat shrink material and any coatings on the wire core will then flow around and encapsulate the wire 112 (FIG. 5C). Once the wire and thermopolymer assembly is complete, the supporting mandrel 118 may be removed, leaving a flexible, hollow tube. The same technique can be performed with a wire mesh in addition to the coil of wire, or instead of the coil of wire. The pitch of the wire wound around the mandrel 118 may also be varied prior to the application of heat shrink. This may be accomplished by alternating thermoplastic elements that have no wire core between windings 113 of those that have the wire core 112, as shown in FIG. 6A. After the application of heat and the flow of the thermopolymer, this results in differences in the space between each turn of wire, affecting the overall pitch (FIG. 6B). The profile of the thermopolymer elements that have no wire core may be round, square, rectangular, or any other desired shape, and the wire 112 need not be originally coated with thermoplastic, nor are they necessarily the same size (FIG. 6C). The cross sectional area of the thermopolymer-only elements need not have the same cross-sectional area as those containing wire (FIG. 6D).

[0089] Another means of manufacturing the insertable length of the overtube is to wrap at least one layer of a thin rolled sheet 120a around a mandrel 118, and then fuse the layers together using heat, adhesives or chemical means. This is shown in FIG. 7. Reinforcing elements, e.g., wire and/or mesh, may be incorporated underneath, in between or on top of the rolled sheets in order to create an overtube with encapsulated support elements.

Bougie at Distal End

[0090] The distal tip may maintain the same outer diameter (hereinafter "OD"), inner diameter (hereinafter "ID") and wall thickness as the rest of the tube, or it may taper slightly to form a gentle curve. When an optional taper is incorporated into the distal tip, this serves to facilitate introduction into a patient's gastrointestinal tract, as well as helping to prevent tissue from being drawn into, and potentially pinched between, the overtube and any loose fitting components

inserted into its inner lumen. As illustrated in the embodiments of FIGS. 8 and 8A, the distal end of the overtube 100 may be used in combination with a Bougie 124 attached to the distal tip of instruments, such as a flexible endoscope 126 for visualization, inserted to the distal end of the overtube. For reference, a Bougie is a smooth bullet-shaped leading tip that facilitates introduction into a lumen. The Bougie OD should be sized such that it creates a snug fit with the ID of the overtube's distal end.

[0091] Alternatively the overtube may be inserted over a guide wire 128 (FIG. 8B); the guidewire inserted under direct visualization using an endoscope. A transition member 130 is positioned between the inside diameter of the overtube and the outside diameter of the guidewire providing for a smooth transition. This transition member preferably includes a long taper, and is composed of a soft, flexible material such as silicone. As shown in FIG. 8A, a similar transition member may be used in place of the Bougie of FIG. 8.

[0092] An alternate means of achieving a gently curved leading edge is by means of a protective, thin walled umbrella-like cap 132 positioned at the distal end of the overtube. During insertion, the umbrella is positioned so that it fits snugly over the distal opening of the overtube, maintaining a dome shape and creating the gently curved bullet shape that facilitates insertion and prevents damage to tissue (FIG. 9A). When the desired insertion depth has been achieved with the overtube, the umbrella may be removed by either pulling it back using an element such as a wire 134 or cable and thus inverting it so that it fits into the overtube's lumen (FIG. 9B), or by pushing it forward with an element such as a wire 134 or cable from the distal end of the overtube, causing the umbrella to close before withdrawing it through the overtube (FIG. 9C).

Expandable Elements

[0093] FIG. 10 illustrates how the distal end of the overtube assembly 100 may optionally include attachments or features, such as an array 136 of spreadable fingers 138. Such an expandable element can be used to push the stomach wall away from the overtube, expanding and increasing the amount of space available within the stomach to perform a procedure. An overtube may incorporate or omit such expanders. The benefits of increasing the volume within the stomach include improvements in the ability to introduce and manipulate tools, improvements in the ability to locate plications and staples, improved ability to deploy implantable devices and improved visualization. Essentially, there is more room to work, and this simplifies many of the tasks. In addition to increasing the volume within the stomach, the expanders may be used to reshape the stomach in a way that facilitates the performance of the procedure. For instance, when the expander is at least partially expanded, the overtube may be pulled back slightly to pull up on the LES and reshape the stomach from its normal dome-like shape into something more resembling a cone. During introduction of the overtube into the esophagus, the expander is preferably in its fully retracted state, so that it presents a smooth cone shape that facilitates insertion. Once the desired location has been reached with the distal end of the overtube (e.g., once past the LES), the expander may be caused to open partially or fully to increase the available working volume and reshape the stomach as desired. Expansion of such elements also serves to help position and support the distal end of the overtube relative to the stomach, stabilizing it and helping it maintain position.

[0094] FIG. 11 shows one embodiment of the expandable elements, in the form of spreadable fingers 138. The position of the fingers may be adjusted and maintained anywhere between a fully closed position (FIG. 11A) and a fully expanded position (FIG. 11B). In this embodiment, this motion is created by changing the relative position of two control rings 140, 142 by means of at least one actuator, for example a Bowden cable. In the illustrated embodiment, movement of ring 140 pivots a hinge 144 coupled to fingers 138. At least part of the more distal control ring 140 may be sized slightly smaller than the more proximal control ring 142 so that it fits or nests at least partially within the proximal control ring 142. During introduction of the overtube into the esophagus, the fingers are preferably in their fully retracted state, so that they present a smooth Bougie-like leading edge that facilitates insertion (FIG. 11A). Once in the desired location, the fingers may be expanded partially or fully to increase the available working volume and reshape the stomach (FIG. 11B). The fingers may be left in this position for the duration of the procedure, or they may be adjusted at any time as desired by the user.

[0095] An additional embodiment of spreadable fingers is shown in FIG. 12. This version of the expandable element again incorporates two control rings, one distal 140a and one proximal 140b. However, this design differs in that the spreadable fingers do not reach forward (more distal) of the distal control ring when they are fully retracted. Rather, these spreadable fingers include a hinge 146 at or near the midpoint so that they form a link located between the control rings, in effect forming a tube-like, scaffold structure. Like the embodiment described in the previous paragraph and depicted in FIG. 11, pulling the distal control ring 140a towards the proximal control ring 140b causes the fingers to spread and deploy. The rings may be approximated by any number of actuator types, such as the pullwires/Bowden cables 148 depicted in FIG. 12 which can be used to draw the rings 140a, 140b together, such as by drawing the distal ring 140a towards the proximal ring 142a. At least one Bowden cable may be used, however using two or more Bowden cables allows for balancing the actuation forces more evenly around the control ring. FIG. 12A shows this version of the spreadable fingers in its fully retracted position, FIG. 12B shows it partially expanded, and FIG. 12C shows it fully extended. The control rings may optionally incorporate features that mate when the fingers are fully deployed to provide a positive stop when the full range of motion has been achieved.

[0096] Another embodiment of a mechanism that may be used to control the degree of expansion of such spreadable fingers employs a Bowden cable attached at the distal end to each finger in order to determine its position. When tension is applied to each Bowden cable, either separately or simultaneously, the corresponding finger moves radially outward, creating a larger working space.

[0097] In cases where an array of spreadable fingers are used to create the expandable element, such as that shown in FIG. 11, these fingers may also be used to maintain orientation during a procedure. Because the image from an endoscope may be rotated and may change unpredictably during the course of a procedure, features that aid in determining location and orientation are helpful. Using landmarks such as the spreadable fingers, especially when they have been individually identified, e.g., with color codes or other markings, aids in determining position of instruments and visualization

components. They are especially useful for determining angular position, or “clocking”.

[0098] In addition to facilitating introduction of the overtube and enabling users to increase the working volume and reshape the stomach during a procedure, the expandable elements, such as the fingers described above and in FIG. 11, may serve as attachment points for a variety of additional devices. In one case, they may have pads 150 attached at their distal ends that increase the surface area they present to the stomach wall when deployed, resulting in a more desirable distribution of forces and a more desirable shape (FIG. 13A). In another case, the pads 150a may be shaped to form a cone when the expandable elements are retracted to their closed position, facilitating introduction of the overtube into the patient (FIG. 13B). In another case, the pads may be configured to form suction cups 150b, which may be applied to the stomach wall and fixed in place when suction is supplied (FIG. 13C). The use of suction immobilizes the stomach tissue relative to the distal end of the overtube. In another case the pads may have a deployable implant 152, such as the restrictor discussed above, temporarily mounted that, from this lead position at the distal tip of the overtube, may be delivered to one or more desired sites (FIG. 13D). Expansion of the fingers may then be used to deploy the implant within the stomach.

[0099] One embodiment of a mechanism that may be used to control the degree of spread of such expandable fingers, or any other embodiment that may be effectively controlled by means of Bowden cables 148, is shown in FIG. 14. This control handle serves to adjust the position of an inner control cable relative to an outer compressive housing of a Bowden cable 148. To accomplish this, an outer cup 154 is used in conjunction with a slidable plate 156. The slidable plate 156 is threaded, and acts like a nut when used in combination with a thumbscrew 158, which moves the slidable plate 156 towards or away from the outer cup 154 when it is turned. The thickness of the slidable plate and the clearance between its outer edge and the inside edge of the outer cup serve to keep the slidable plate aligned and prevent it from binding within the cup as it moves. Binding and misalignment may be further prevented via the addition of alignment slots 160, mated to pins 162 that protrude from the slidable plate. The controller may act on at least one Bowden cable, and the cables may be, but are not necessarily, centered or balanced with respect to the slidable plate. Adjustment of the Bowden cable may be accomplished with a barrel adjuster, or similar component. If a barrel adjuster is used, it may be comprised primarily of a screw which has a hole drilled through its central axis. The Bowden cable's compressive housing terminates against the screw head while the inner control cables runs through the screw. When the screw is inserted into a threaded hole, and the cable is attached to a component (such as the slidable plate shown in FIG. 14), the relative positions of the inner cable and outer compressive housing are adjusted.

[0100] When retraction of the expandable elements is desired, it may be advantageous or required, depending on the construction, to incorporate components within the mechanism of the expanders to ensure that they reliably retract. For instance, in cases where Bowden cables are used to actuate an expandable element, friction between the control cable and the compressive housing may prevent the expandable element from returning to a retracted position. For the embodiment shown in FIG. 11, this may be accomplished by means of a compression spring that pushes the two control rings apart.

Alternately, nitinol spring elements may be incorporated to act upon the outer face of each of the fingers when they are extended, so that they push the fingers back to the retracted position when tension is removed from the Bowden cable that pulls the control rings together.

[0101] An alternate embodiment of an expandable element located at the distal end of the overtube or on a separate elongate member passed through the overtube, is shown in FIG. 15. In this embodiment, a fully expanded pair of hoops are comprised of numerous piecewise sections 166 which have central tensioning cables 168 running through their centers. When the tensioning cables are relaxed, the hoop sections are free to move relative to each other, and the result is a flexible chain of short elements. This configuration is well suited for insertion of the device through the overtube. When the tensioning cable is placed in tension, the hoop sections are forced to join together and organize into a shape that creates additional volume within the stomach, such as the hoops, or globe, shape shown. In this example, a hoop shape is depicted, however other shapes are possible and may be desirable, such as triangles, squares, umbrellas, etc.

Articulatable Section

[0102] At least one articulatable, lockable section may optionally be incorporated within the insertable length of the overtube. FIG. 16 shows a version of the overtube that incorporates such an articulatable length, labeled 103. The purpose of the articulatable section is to facilitate positional control of instruments and devices inserted through the lumen defined by the overtube. For instance, an articulatable section may be steered (caused to bend at a desirable angle and direction), to impart a "hockey stick" shape to the insertable length of the overtube. Additionally, the shape of the articulatable section may be locked in place by immobilizing or otherwise constraining the actuating elements that determine its shape. The simplest embodiments of the overtube may incorporate no such articulating section, being comprised entirely of a passive tube, as described above and depicted in FIG. 3. However, at least one articulatable section may be incorporated in such a way that it is coaxial and continuous with other passive, non-articulatable sections of the overtube. The articulatable section(s) have an OD, ID and wall thickness similar, but not necessarily equal, to those of the passive overtube sections. FIG. 16 shows the configuration of the articulatable section(s), which may be located at the distal end of the overtube, such that the section 108 has minimal length or zero length. Alternately, the articulatable sections may be located between passive sections of the overtube, such that the length of sections labeled 108 and 102 are non-zero. Similarly, the articulating section may be located at the proximal end of the overtube so that the length of the passive section 102 has minimal or zero length. In cases where more than one articulating section is incorporated, they may be located in any of the positions defined above, and they may be located next to each other or separated by passive sections. The preferred number of articulating sections is either zero or one, and the preferred location of the articulating section is near the distal end of the overtube, such that the length of the passive section 108 is between 0-6 in.

Steering Controls

[0103] Steering control of the articulatable section may be achieved by a variety of methods. The preferred method is to

control articulation with at least one pull cable, such as a Bowden cable, acting within a coil tube compression housing. A single such control cable can be used to control the shape of the articulatable section in one direction (e.g., to the right), or a single cable can be used in combination with an opposing spring element to cause articulation in two directions (e.g., the spring pulls to the left and the cable pulls to the right). Alternately, two control cables can be used to control articulation in two directions (e.g., left and right). Extending this further, three control cables can be used in combination to allow for articulation in all directions (e.g., left, right, up and down), or four control cables can be used, each directly controlling bending of the articulatable section in each direction. The use of four control cables is the preferred method, as the resulting control is simple and intuitive for the user.

[0104] The control cables may be used to steer, or determine the curvature of, the articulating section of the overtube. FIG. 22 shows an example where two control cables are used to control the articulation angle Θ of a distal articulatable section in two directions, up (U) and down (D). The coil tube housings associated with the control cables are routed from a rotating control knob 170 located at the proximal end of the overtube assembly, down the length of the overtube to the junction between the length of passive overtube 102 and the articulatable section 103 controlled by the knob 170. Rotating the control knob in one direction results in one control cable being pulled in and an opposing control cable being spooled out. Similarly, rotating the control knob in the opposite direction reverses these motions. The resulting motion and forces are transmitted down the length of the control cables and compression housings to the articulatable length of overtube, and determine the major (inner) and minor (outer) arc lengths of the articulating section. As an example, FIG. 22 illustrates the case where the control knob is rotated clockwise by the user. This results in the upper control cable 172 being pulled relative to its compression coil tube housing 174, and this defines the minor arc length (l) along the top edge of the articulating length. Simultaneously, the rotation of the knob 170 releases tension on and feeds out the bottom control cable 176 relative to its corresponding compression coil tube housing 178, defining the major arc length (L) along the bottom edge of the articulating section. Variations of this design may incorporate four control cables, each determining the bending of the articulatable section in a different direction, such as left, right, up and down. For this case, two knobs are used. One knob controls one pair of control cables, e.g., the left-right pair, and the other knob controls the other pair of control cables, e.g., the up-down pair. The steering control knobs may optionally be oriented so that their position relates to the direction of steering they control. For example, when two knobs are used with one knob controlling left-right bending and the other knob controlling the up-down bending, the knobs may be rotated relative to one another by 90°. Further, the knobs may be oriented so that the position of the knob controlling bending in the left-right directions is horizontal and the position of the knob controlling bending in the up-down directions is vertical.

[0105] The length of each of the Bowden cables is critical to their correct performance, and for this reason elements that facilitate their adjustment are helpful. Even in cases where they have been cut to the exact length required and perfectly installed, cables typically stretch over time and use, and will require periodic adjustment. For this reason, the control knob assemblies may incorporate a number of means of cable

adjustment. One useful characteristic of a control knob is to incorporate a means to deal individually with each control cable that terminates there. For instance, if the control knob determines the shape of the articulatable section in the left-right direction, the cable controlling bending to the left can be managed and kept separate and adjusted independently of the cable controlling bending to the right. This may be accomplished by incorporating two completely separate sections **170a**, **170b** of the control knob, one for each terminating control cable, as illustrated in FIG. 23. In this figure, the 2-part spool is indicated with the reference numerals **171a**, **171b**. Coarse cable adjustment can be provided by incorporating a multitude of attachment points between the knob described in the paragraph above and the Bowden cable. The spool around which the control cable is wound requires a single potential attachment point, such as a pin, for a control cable, however if multiple potential attachment points are provided, the length of the cable may be adjusted relative to the position of the spool and knob. The example shown in FIG. 24A has potential attachment point **173** spaced every 15°, however this spacing may be any useful interval. The route of the control cable wire to the control knob termination point is preferably but not necessarily smooth, so that it does not present any hard corners or sharp edges to the cable, extending its operating life. Fine cable adjustment may be accomplished with the addition of a barrel adjuster or similar element. In the case of a barrel adjuster, a screw is drilled through its central axis, and the cable's compressive housing terminates against the screw head while the inner control cable runs through the screw. When the screw is inserted into a threaded hole **182**, and the cable is attached to a component (such as the spool shown in FIG. 24A), the relative positions of the inner cable and outer compressive housing may be adjusted by the position of the screw. Turning the screw so that it moves towards the cable's termination point (e.g., clockwise for right-handed threads) loosens the cable. Conversely, turning the screw so that it moves away from the cable's termination point (e.g., counter-clockwise for right-handed threads) tightens the cable. This is depicted in FIG. 24B.

[0106] Control of an articulating section may also be achieved by means other than Bowden cables. Any appropriate alternate actuation method and energy source may be used, such as hydraulic or pneumatic actuators, which could be used to create the motion and forces needed to bend the articulatable section.

Articulatable Section Construction

[0107] The articulatable sections may be constructed using a variety of techniques. One simple embodiment consists of a single coil spring element **112** capable of bending as desired, and is shown in FIG. 17A. The proximal **184** and distal **186** ends of the spring are fitted with end caps **188** that provide termination points for actuating elements (described below) and mounting features for attaching them to other parts of the overtube's insertable length. Additional features may be useful for routing components that traverse through the articulatable section, such as Bowden cables running between the user controls at the proximal end and the expandable elements at the distal tip. The spring element **112** may have significant space between the coil windings so that it bends freely when a moment is applied between the distal and proximal ends without changing length significantly. To cause the spring to articulate, a Bowden cable may be used, attached across one

side of the outside of the spring element. If the Bowden cable's compressive housing terminates at the proximal end cap **188a** of the spring element, and the control cable terminates at the distal end cap **188b** of the spring element, pulling on the cable relative to the compressive housing results in the spring bending in the direction of the cable, as shown in FIG. 17B. A backbone **190** extending through the overtube prevents collapse of the spring during bending. Bending the spring element in other directions is achievable by attaching additional Bowden cables in other locations around the outside of the spring element. A benefit of this construction is that the spring element comprising the articulatable section returns to a straight shape when tension is released from the control cables: its relaxed configuration is straight. The spring element comprising the articulatable section of this construction may be created by attaching a separate spring to passive sections of the overtube to create the full insertable length of the overtube, or it may be formed from the same materials used as the supporting structure of the passive sections of the insertable overtube. This can be accomplished by altering the winding pitch and/or the diameter locally, if needed, where the articulatable section is required.

[0108] An alternative means of constructing an articulatable section is to create it by stringing together on cables **194** a succession of rings shaped in such a way that they are allowed to rock relative to one another. The rocking motion can again be controlled through the use of Bowden cables. This construction technique is illustrated in FIG. 18A through D. The shape of each ring is such that it forms an inner lumen, and is preferably (but not necessarily) round. The inner radius r is sized so that it is approximately the same as the inner radius of the rest of the insertable length of the overtube. The outer radius R and the wall thickness T are equal to or as close as possible to the outer radius of the rest of the insertable length of the overtube. Four small through holes are drilled through each ring's wall parallel to the central axis of the overtube, at the 3, 6, 9 and 12 o'clock positions. These holes accept the control cables **194**, which run through each ring and hold the assembly together. When viewed from the side, as shown in FIG. 18A, each ring is flat along the bottom surface and has two aligned raised arches along the top surface. In the figure, these are shown in the 12 and 6 o'clock orientation. The raised sections are oriented so that their peaks are coincident with the small holes drilled through the wall. To assemble the articulatable section, a number of rings are strung together using control cables **194**. At the distal end of the assembly of rings, each cable is terminated, e.g., with a crimp **196**. At the proximal end of the assembly of rings, each compressive housing is terminated. When sufficient tension is applied to a control cable, it will pull back and move into its compressive housing, and the corresponding side of the distal end of the assembly of rings is pulled towards the proximal end. The cables themselves constrain the relative motion of the rings so that the result is piecewise bending. This is shown in FIG. 18B and FIG. 18D. The rings are prevented from sliding relative to each other and losing organization by the cables that connect them. Such rings may be comprised of any of a variety of materials that possess adequate strength, however stainless steel or polycarbonate are preferred.

[0109] The arrangement of the rings relative to each other in the assembly determines whether bending in two directions results (e.g., left and right) or whether bending in four directions (e.g., left, right, up and down) is allowed. FIGS. 18A and B show the construction that results in articulation in two

directions (left and right). For this construction, the raised portions of each of the rings are all oriented similarly, e.g., from the 12 o'clock position to 6 o'clock position. When control cables are actuated at the 3 o'clock position or the 9 o'clock position, the assembly is caused to rock in the direction of the cable under tension. For this construction, all of the rings contribute to the bending of the assembly. The other two cables (at 12 o'clock and 6 o'clock) are always held at a fixed length and pretension, and applying further tension to them would not result in bending the articulatable section. Instead, these cables serve primarily to string the rings together and stabilize the assembly. They may terminate immediately at the proximal end of the articulatable section, without the use of compressive housings, or they may optionally extend back to the proximal controls.

[0110] FIGS. 18C and D show a variation of the construction that enables the assembly of rings to articulate in four directions (left, right, up and down). For this construction, the raised portions of each of the rings are alternated, rotated 90° between successive rings. When any of the four control cables is actuated, or combinations of control cables, the assembly is caused to rock in the direction of the cable(s) under tension. For this construction, each ring contributes to the bending of the assembly in two of the four possible directions, such as the left and right pair. Every other ring contributes bending in the left-right directions, alternating with rings that contribute bending in the up-down directions. FIG. 18D illustrates the contributions of each of the rings in the assembly when a single cable is pulled.

[0111] These stacked ring embodiments of the articulatable section may also be used to construct unarticulatable sections. Such sections are flexible, but their articulation is not selectable or controllable by a user. When this approach is used, the entire length of the overtube may be constructed using a continuous assembly of rings, oriented in at least one of the ways described above. The shape of at least one region of the assembly may be controllable (e.g., articulatable or steerable) via Bowden cables, as described, while the remaining regions of the assembly which are not controllable have no Bowden cables determining their shape.

[0112] Another embodiment of an articulatable section is shown in FIG. 19. In this version, rings 198 that are joined with hinge joints 200 are combined to form an assembly that may be caused to articulate in a desired direction by means of an actuator that pulls differentially in a given direction, such as a Bowden cable. The orientation of successive hinges may alternate in increments of 90° as shown, which enables bending in four directions (e.g., left, right, up and down), or all hinges may be aligned in the same orientation, which will allow for bending in two directions (e.g., left and right). As with the previously described embodiment, the balance of the insertable length of the overtube may also optionally be made using this construction. A single section, multiple sections, or no section may then optionally be made articulatable by means of actuators such as Bowden cables.

[0113] Regardless of the construction of the articulatable section, it may have either a continuous outer sheath 202 or surface, a continuous inner sheath 204 or surface, or both (e.g., sheaths positioned over the inner and outer surfaces of the articulating rings, coil or other articulating features, or an encapsulation/positioning of such articulating features within the walls of a sheath). This is shown in FIG. 20. The material used to create the sheath preferably offers little resistance to the bending of the articulatable section. For this reason, soft

materials, such as a low durometer, thin wall urethane, silicone or similar material are preferred. The overtube's terminating end piece provides an air tight seal against devices inserted through the inner lumen for the purpose of facilitating and maintaining insufflation of the stomach during a procedure, and if the overtube is not a continuously sealed tube along its insertable length, air leaks are likely to occur. Insufflation facilitates visualization and access by increasing the volume of the stomach where the procedure is performed, and when insufflation is not adequate, the procedure may be negatively impacted.

[0114] Components may be added to or incorporated within the overtube to provide tactile feedback to users when instruments within the overtube's inner lumen are moved. For example, elements may be used that provide the sensation of indexing, such as a ratcheting feel of engagement and disengagement, when an instrument is inserted into the overtube to specific depth intervals, or rotated relative to the overtube 100 at angular intervals. One embodiment of such a feature makes use of magnetic interactions. If at least one magnet 206 or magnetically attractive element is incorporated into the overtube, and a corresponding magnet 208 or magnetically attractive element is incorporated into an instrument 210 that moves relative to the overtube, the elements will attract or repel each other as they move into and out of proximity. This is illustrated in FIG. 21. These forces may be useful to the user to indicate that a location of interest has been achieved, or that a certain increment of motion has occurred. Another embodiment of such a feature involves a ball detent, mounted either in the overtube or in an insertable instrument that indexes against indentations in a mating surface. The indentations may be either circular or elongate in shape.

Depth and Angle Markings

[0115] The proximal end of the overtube may incorporate graduated markings indicating depth and radial angle (FIG. 25). The depth markings 212a enable users to quantitatively track and control the depth of insertion of the overtube into the patient, as well as the depth of insertion of instruments, tools and devices into the overtube. The radial angular markings 212b similarly enable users to quantitatively track and control the angular position (also called "clocking") of the overtube and the instruments, tools and devices inserted into the overtube. The depth and angle markings also enable users to repeatedly return an instrument or device to a previously achieved location when required. Additionally, the depth and angle markings enable users to reposition instruments and devices at a known location relative to a previously achieved location. For example, if a physician wishes to create a new stapled mounting point in the stomach wall at a location 90° clockwise and at an equivalent distance from the LES relative to a previously placed stapled mounting, he or she would ensure that the overtube was inserted to the same depth and angular position into the patient for both sequences of operations, that the instruments used were inserted into the overtube at the same depth, and that the instruments were rotated 90° clockwise as indicated on the overtube's angular markings.

Color Coding to Indicate Orientation

[0116] The angular markings at the proximal end of the overtube may be further identified by means of color coding (FIG. 26). For instance, the quadrant from 0° to 90° may be

indicated with the color green (G), the quadrant from 90° to 180° with red (R), 180° to 270° with blue (B), and 270° to 0° with no color (NC) added. These color codings may be coordinated with similar markings at the distal end of the overtube **110** which will be visualized with an endoscope. This improves the ability of the user to maintain proper orientation and obtain the desired result when manipulating instruments at the proximal end of the overtube, since it directly corresponds to what he or she observes visually at the distal end of the overtube. The color coding at the distal end of the overtube may be applied anywhere that may be visualized by an endoscope placed inserted through the inner lumen, such as to the overtube itself (including passive and/or articulatable sections), or to components attached to and extending beyond the distal end of the overtube. For instance, expandable elements such as spreadable fingers may be added to the end of the overtube which may each be a unique color. Alternately, components may be extended from the distal end of the overtube for the express purpose of placing color coded markings within the field of view of the endoscope (FIG. 27). These forward-extending components may be of any useful shape, e.g., a tubular antenna, or a garden-hoe-like flag.

[0117] The steering controls that determine the angle and direction of the articulatable section may also be marked to correspond to the markings on components at the distal end of the overtube. If, for instance, the spreadable finger located at the top of the overtube (at the 12 o'clock position) is red, the control knob that determines the up-down position of the articulatable section will have a red marking on it indicating which direction it should be turned to cause the articulatable section to bend in the up direction. Similarly, if the spreadable finger located at the bottom of the overtube (at the 6 o'clock position) is blue, then markings on the same knob will incorporate an indication of which direction it should be turned to cause the articulatable section to bend down. This may be done, for example, by marking the knobs with different color arrows.

[0118] In addition to indicating which direction to turn each knob to achieve the desired bend angle with the articulatable section, each knob may be marked with an indication of when the articulatable section is approximately straight. A marking indicating the "neutral" position of the articulatable section allows a user to straighten the articulatable section with high confidence, rather than relying on "feel" or for the articulatable section to return to a straight configuration if tension is released on the controlling Bowden cables.

[0119] A positive retention force and tactile feedback may also be provided in the steering control knobs by incorporating ball detent components and a sequence of mating indentations. When a user turns a steering control knob, the ball detents can prevent the knob from turning freely, thus preventing the articulatable section from unintentionally returning to its relaxed neutral position. The indexing that occurs as the ball detent moves through the succession of indentations may also provide useful tactile feedback to the user, indicating increments of rotation of a knob and/or certain positions of the articulatable section, such as straight or neutral.

Terminating End Ring

[0120] The proximal end of the overtube incorporates a terminating end ring (FIG. 28). The end ring is attached to, and is not free to move relative to, the insertable length of the overtube. The end ring incorporates at least one sealing feature for the purpose of creating and maintaining an air-tight

seal against components inserted into its inner lumen. When insufflation or suction is applied through the overtube or by instruments passing within the overtube, this seal prevents flow between the inside and the outside of a patient. The sealing feature may take the form of at least one o-ring, but preferably two o-rings. Additionally, the end ring incorporates a port for the introduction of insufflation. This port accepts tubing through which insufflation air may flow. Optionally, a clamp valve may be installed over the insufflation tubing to control the flow of air, or the flow may be controlled by means of turning the insufflation pump on and off.

Fixturing Ring

[0121] Over the terminating end ring, a fixturing ring **220** (FIG. 29) may be fitted that facilitates attachment to a clamping or fixturing device, such as an iron intern. For this reason, this device may also be referred to as an "iron intern ring". The iron intern ring fits loosely over the terminating end ring, so that it is possible to rotate them relative to each other. The fixturing ring also incorporates at least one tensioning element that, when active, immobilizes the terminating end ring relative to the fixturing ring. This tensioning element may be embodied, for example, by at least one screw **222** that, when tightened, locks the terminating end ring relative to the iron intern ring, preventing rotation and axial motion. Preferably, more than one screw is used to distribute the clamping load. For example, three clamping screws are shown in FIG. 29. This screw may also incorporate features that facilitate frequent adjustment without requiring the use of tools. For instance, large knobs may be located on the screw heads to enable users to tighten and loosen them by hand. The iron intern ring is also the mounting point for elements of the overall device that are inconvenient to rotate in the event that the insertable length of the overtube is torqued. This includes the steering controls for the articulatable, lockable section of the overtube and the position control from the expandable elements, such as the embodiment shown in FIG. 14. In one embodiment, the steering controls (e.g., left-right control **226** and up-down control **228**) and the expandable element controller **230** are incorporated into a single component, and this component is attached to the iron intern ring (FIG. 30).

[0122] An overtube may be packaged alone or as a system in combination with related components such as staplers and implants of the type referenced in the application, as well as any combination of the following: Bougies, transition members, guidewires, endoscopes etc. The system might further include instructions for use instructing a user to employ the system in accordance with the methods disclosed herein.

[0123] As is apparent from the forgoing disclosure, in some embodiments described above, the overtube comprises an articulating section, an actuator for effecting articulation of the articulating section, and an optional locking mechanism allowing the articulating section to be locked in a desired position. In other embodiments described above, the overtube comprises an elongate tube having one or more retraction elements on its distal end, allowing the overtube to create working space within the body (e.g., stomach) while giving access to instruments passed through its lumen.

[0124] It should be recognized that a number of variations of the above-identified embodiments will be obvious to one of ordinary skill in the art in view of the foregoing description. Accordingly, the invention is not to be limited by those specific embodiments and methods of the present invention

shown and described herein. The applications and methods listed are not limited to the treatment of diseases or procedures listed. Modifications of the above described methods and tools and variations of this invention that are obvious to those of skill in the art are intended to be within the scope of this disclosure. Moreover, the disclosed embodiments may be combined with one another in varying ways to produce additional embodiments.

[0125] Any and all patents, patent applications and printed publications referred to above, including those relied upon for purposes of priority, are incorporated herein by reference.

We claim:

1. An endogastric overtube for use in a stomach of a patient, comprising:

a flexible elongate tube having a proximal end and a distal end, the tube proportioned such that when the distal end is in the stomach, the proximal end is positioned outside the patient, the tube including at least one lumen extending from the proximal end to the distal end, the tube having a maximum outer diameter of at least approximately 10 mm; and

a control cable extending through a wall of the tube, the control cable coupled to a distal portion of the tube such that engagement of the control cable causes deflection of the distal portion.

2. The endogastric overtube of claim 1, wherein the tube further includes a reinforcement on a distal portion of the tube.

3. The endogastric overtube of claim 2, wherein the tube is a formed of polymeric material and wherein the reinforcement is embedded within the polymeric material.

4. The endogastric overtube of claim 2, wherein the tube is a formed of polymeric material and wherein the reinforcement is positioned on an inner surface of the lumen or an outer surface of the tube.

5. The endogastric overtube of claim 2, wherein the reinforcement is a resilient coil.

6. The endogastric overtube of claim 2, wherein the reinforcement is at least one resilient ring.

7. The endogastric overtube of claim 2, wherein the reinforcement is at least one partial ring.

8. The endogastric overtube of claim 6, wherein the resilient ring is circular.

9. The endogastric overtube of claim 6, wherein the resilient ring is elliptical.

10. The endogastric overtube of claim 2, wherein the reinforcement includes a mesh element.

11. The endogastric overtube of claim 2, wherein the lumen has a diameter, and wherein the tube is expandable from a first position to a second position in response to introduction of an instrument having a diameter exceeding the lumen diameter into the lumen, and wherein the reinforcement is configured to restore the tube to the first position upon removal of the instrument from the lumen.

12. The endogastric tube of claim 1, further including a removable atraumatic tip on the distal end.

13. The endogastric tube of claim 12, wherein the atraumatic tip is positioned on an elongate member extending through the lumen.

14. The endogastric tube of claim 12, wherein the atraumatic tip is a cap at least partially covering the distal end of the tip.

15. The endogastric tube of claim 12, wherein the elongate element is retractable in a proximal direction to invert the cap into the lumen.

16. The endogastric tube of claim 12, wherein the elongate element is advanceable in a distal direction to collapse the cap into a collapsed position, and wherein the elongate element is retractable to withdraw the cap in the collapsed position through the lumen.

17. The endogastric tube of claim 5, wherein the control cable is coupled to the spring element.

18. The endogastric tube of claim 1, further including a retractor element on the distal end of the tube, the retractor element moveable from a first position to a second position in which the retractor element extends laterally from the tube.

19. The endogastric tube of claim 18, wherein the retractor element extends longitudinally when in the first position.

20. The endogastric tube of claim 18, wherein the retractor element includes a first portion coupled to a first ring and a second portion coupled to a second ring, and wherein relative movement of the second ring towards the first ring moves the retractor element from the first position to the second position.

21. The endogastric tube of claim 20, wherein the retractor element includes a hinge, and wherein the first portion and the second portion are on opposite sides of the hinge.

22. The endogastric tube of claim 20, wherein the first portion is an elongate member, and wherein the second portion is a pivot element pivotably coupled between the elongate member and the second ring.

23. The endogastric tube of claim 18 wherein the retractor element includes a mount for receiving an implant to be implanted in the stomach.

24. The endogastric tube of claim 1, further including a retractor element on the distal end of the tube, the retractor element including a plurality of segments and a cable extending between the segments, the retractor having a first, flexible, position and a second, more rigid, position, the cable retractable to move the retractor from the first to the second position.

25. The endogastric tube of claim 24, wherein the segments are positioned on a cable loop and wherein the retractor element in the second position forms a retractor hoop.

26. The endogastric tube of claim 25, further including a second retractor element including a plurality of second segments and a second cable extending between the segments, the second cable retractable to move the second retractor from a flexible position to a more rigid position.

27. The endogastric tube of claim 26, wherein the second retractor in the second position forms a retractor hoop.

28. The endogastric tube of claim 1, wherein the tube includes a seal positioned to seal against an instrument inserted into the lumen.

29. The endogastric tube of claim 1, wherein the proximal portion of the tube includes a port positionable in fluid communication with a source of insufflation gas.

30. The endogastric tube of claim 1, wherein the tube has a maximum outer diameter of between approximately 10 mm-20 mm.

31. The endogastric tube of claim 30, wherein the tube has a maximum out diameter of between approximately 15 mm-20 mm.

32. The endogastric tube of claim 30, wherein the tube has a maximum outer diameter of approximately 20 mm.

33. The endogastric tube of claim 1, wherein the tube has a maximum outer diameter of approximately 18-22 mm.

- 34. The endogastric tube of claim 1, wherein the tube has a maximum wall thickness of 0.1-0.2 mm.
- 35. An endogastric overtube for use in a stomach of a patient, comprising:
 - a flexible elongate tube having a proximal end and a distal end, the tube proportioned such that when the distal end is in the stomach, the proximal end is positioned outside the patient, the tube including at least one lumen extending from the proximal end to the distal end, the tube having a maximum outer diameter of at least approximately 10 mm; and
 - a retractor element on the distal end of the tube, the retractor element moveable from a first position to a second position in which the retractor element extends laterally from the tube.
- 36. The endogastric tube of claim 35, wherein the retractor element extends longitudinally when in the first position.
- 37. The endogastric tube of claim 35, wherein the retractor element includes a first portion coupled to a first ring and a second portion coupled to a second ring, and wherein relative movement of the second ring towards the first ring moves the retractor element from the first position to the second position.
- 38. The endogastric tube of claim 37, wherein the retractor element includes a hinge, and wherein the first portion and the second portion are on opposite sides of the hinge.
- 39. The endogastric tube of claim 37, wherein the first portion is an elongate member, and wherein the second portion is a pivot element pivotably coupled between the elongate member and the second ring.
- 40. The endogastric tube of claim 37, wherein the retractor element includes a mount for receiving an implant to be implanted in the stomach.
- 41. The endogastric tube of claim 35, further including a retractor element on the distal end of the tube, the retractor

- element including a plurality of segments and a cable extending between the segments, the retractor having a first, flexible, position and a second, more rigid, position, the cable retractable to move the retractor from the first to the second position.
- 42. The endogastric tube of claim 41, wherein the segments are positioned on a cable loop and wherein the retractor element in the second position forms a retractor hoop.
- 43. The endogastric tube of claim 42, further including a second retractor element including a plurality of second segments and a second cable extending between the segments, the second cable retractable to move the second retractor from a flexible position to a more rigid position.
- 44. The endogastric tube of claim 43, wherein the second retractor in the second position forms a retractor hoop.
- 45. The endogastric tube of claim 35, wherein the tube includes a seal positioned to seal against an instrument inserted into the lumen.
- 46. The endogastric tube of claim 35, wherein the proximal portion of the tube includes a port positionable in fluid communication with a source of insufflation gas.
- 47. The endogastric tube of claim 35, wherein the tube has a maximum outer diameter of between approximately 10 mm-20 mm.
- 48. The endogastric tube of claim 47, wherein the tube has a maximum out diameter of between approximately 15 mm-20 mm.
- 49. The endogastric tube of claim 35, wherein the tube has a maximum outer diameter of approximately 20 mm.
- 50. The endogastric tube of claim 35, wherein the tube has a maximum outer diameter of approximately 18-22 mm.
- 51. The endogastric tube of claim 35, wherein the tube has a maximum wall thickness of 0.1-0.2 mm.

* * * * *