



AU9530621

(12) PATENT ABRIDGMENT (11) Document No. AU-B-30621/95
(19) AUSTRALIAN PATENT OFFICE (10) Acceptance No. 689293

- (54) Title
CHEWING GUM MANUFACTURE USING HIGH EFFICIENCY CONTINUOUS MIXER
- International Patent Classification(s)
(51)⁶ **A23G 003/30**
- (21) Application No. : **30621/95** (22) Application Date : **13.09.95**
- (30) Priority Data
- | (31) Number | (32) Date | (33) Country |
|---------------|-----------------|------------------------------------|
| 305363 | 13.09.94 | US UNITED STATES OF AMERICA |
| 362254 | 22.12.94 | US UNITED STATES OF AMERICA |
- (43) Publication Date : **28.03.96**
- (44) Publication Date of Accepted Application : **26.03.98**
- (71) Applicant(s)
WM. WRIGLEY JR. COMPANY
- (72) Inventor(s)
JOO H. SONG; KEVIN B. BRODERICK; HENRY T. TYRPIN; DAVID W. RECORD; DONALD J. TOWNSEND; JOHN T. WOLFE; CHRISTAFOR E. SUNDSTROM; PHILIP G. SCHNELL
- (74) Attorney or Agent
SPRUSON & FERGUSON , GPO Box 3898, SYDNEY NSW 2001
- (57) Claim

1. A method of manufacturing chewing gum comprising the steps of adding chewing gum ingredients to a high efficiency continuous mixer that includes a conveyor element on a screw of the mixer at a location that is not directly under an ingredient addition port.

AUSTRALIA
PATENTS ACT 1990

COMPLETE SPECIFICATION

FOR A STANDARD PATENT

ORIGINAL

Name and Address
of Applicant:

Wm. Wrigley Jr. Company
401 North Michigan Avenue
Chicago Illinois 60611
UNITED STATES OF AMERICA

Actual Inventor(s):

Joo H. Song, Kevin B. Broderick, Henry T. Tyrpin, David
W. Record, Donald J. Townsend, John T. Wolfe,
Christafor E. Sundstrom and Philip G. Schnell

Address for Service:

Spruson & Ferguson, Patent Attorneys
Level 33 St Martins Tower, 31 Market Street
Sydney, New South Wales, 2000, Australia

Invention Title:

Chewing Gum Manufacture Using High Efficiency
Continuous Mixer

The following statement is a full description of this invention, including the best method of performing it known to me/us:-

CHEWING GUM MANUFACTURE
USING HIGH EFFICIENCY CONTINUOUS MIXER

FIELD OF THE INVENTION

5 This invention is a process for the total manufacture of chewing gum base and chewing gum using a single high efficiency continuous mixer.

BACKGROUND OF THE INVENTION

10 Conventionally, chewing gum base and chewing gum product have been manufactured using separate mixers, different mixing technologies and, often, at different factories. One reason for this is that the optimum conditions for manufacturing gum base, and for manufacturing chewing gum from gum base and other ingredients such as sweeteners and flavors, are so
15 different that it has been impractical to integrate both tasks. Chewing gum base manufacture, on the one hand, involves the dispersive (often high shear) mixing

of difficult-to-blend ingredients such as elastomer, filler, elastomer plasticizer, base softeners/emulsifiers and, sometimes wax, and typically requires long mixing times. Chewing gum product manufacture, on the other hand, involves combining the gum base with more delicate ingredients such as product softeners, bulk sweeteners, high intensity sweeteners and flavoring agents using distributive (generally lower shear) mixing, for shorter periods.

In order to improve the efficiency of gum base and gum product manufacture, there has been a trend toward the continuous manufacture of chewing gum bases and products. U.S. Patent 3,995,064, issued to Ehr Gott et al., discloses the continuous manufacture of gum base using a sequence of mixers or a single variable mixer. U.S. Patent 4,459,311, issued to DeTora et al., also discloses the continuous manufacture of gum base using a sequence of mixers. Other continuous gum base manufacturing processes are disclosed in European Publication No. 0,273,809 (General Foods France) and in French Publication No. 2,635,441 (General Foods France).

U.S. Patent 5,045,325, issued to Lesko et al., and U.S. Patent 4,555,407, issued to Kramer et al., disclose processes for the continuous production of chewing gum products. In each case, however, the gum base is initially prepared separately and is simply added into the process. U.S. Patent 4,968,511, issued to D'Amelia et al., discloses a chewing gum product containing certain vinyl polymers which can be produced in a direct one-step process not requiring separate manufacture of gum base. However, the disclosure focuses on batch mixing processes not having the efficiency and product consistency achieved with continuous mixing. Also, the single-step processes are

limited to chewing gums containing unconventional bases which lack elastomers and other critical ingredients.

In order to simplify and minimize the cost of chewing gum manufacture, there is need or desire in the chewing gum industry for an integrated continuous manufacturing process having the ability to combine chewing gum base ingredients and other chewing gum ingredients in a single mixer, which can be used to manufacture a wide variety of chewing gums.

10 SUMMARY OF THE INVENTION

The present invention provides methods for the continuous manufacture of a wide variety of chewing gum products using a single high efficiency mixer which, in an embodiment, does not require the separate manufacture of chewing gum base. However, the present invention can be used to manufacture gum base or chewing gum from finished gum base. Pursuant to the present invention, a mixer including conveyor elements is utilized. By substituting one or more conveyor elements for mixing elements, overmixing is reduced and throughput is increased.

To this end, in an embodiment, a method of manufacturing chewing gum is provided comprising the steps of adding chewing gum ingredients to a high efficiency continuous mixer that includes a conveyor element on a screw of the mixer at a location that is not directly under an ingredient addition port.

In an embodiment, the high efficiency continuous mixer also includes at least one conveyor element located directly under an ingredient addition port.

In another embodiment, a method of continuously manufacturing chewing gum is provided that comprises the steps of: a) adding a gum base into a high efficiency continuous mixer; b) adding at least

one sweetener and at least one flavor into the continuous mixer, and mixing said sweetener and flavor with the remaining ingredients to form a chewing gum product; and c) wherein after one of the ingredients is added to the mixer, it is subjected to a conveyor element on a screw of a single high efficiency continuous mixer.

In another embodiment, a method of continuously manufacturing chewing gum without requiring the separate manufacture of a chewing gum base is provided comprising the steps of: a) adding at least an elastomer and filler into a high efficiency continuous mixer that includes mixing and conveyor elements; b) subjecting at least the elastomer and filler to dispersive mixing in the continuous mixer; c) adding at least one sweetener and at least one flavoring agent into the elastomer and filler in the continuous mixer; d) subjecting at least the sweetener, flavoring agent, elastomer and filler to distributive mixing in the continuous mixer, to form a chewing gum product; and e) continuously discharging the chewing gum product from the mixer.

In yet another embodiment, a method of continuously manufacturing chewing gum without requiring the separate manufacture of a chewing gum base is provided comprising the steps of: a) adding at least an elastomer and filler into a blade-and-pin mixer, and mixing the elastomer and filler together using blades and pins; b) adding at least one ingredient selected from the group consisting of fats, oils, waxes and elastomer plasticizers into the blade-and-pin mixer, and mixing said at least one ingredient with the elastomer and filler using blades and pins; c) adding at least one sweetener and at least one flavor into the blade-and-pin mixer, and mixing said sweetener and flavor with the remaining ingredients to form a

chewing gum product; and d) wherein the mixer includes at least one conveyor element which is not directly under an ingredient addition port.

Additionally, the present invention provides chewing gum manufactured pursuant to the methods of the present invention.

A high efficiency continuous mixer is one which is capable of providing thorough mixing over a relatively short distance or length of the mixer. This distance is expressed as a ratio of the length of a particular active region of the mixer screw, which is composed of mixing elements, divided by the maximum diameter of the mixer barrel in this active region. In an embodiment, the method of the invention comprises performing the following mixing steps in a single continuous mixer:

a) adding and thoroughly mixing at least a portion of the chewing gum base ingredients (elastomer, elastomer plasticizer, filler, etc.) in a continuous mixer, using an L/D of not more than about 25;

b) adding at least a portion of the remaining (non-base) chewing gum ingredients (sweeteners, flavors, softeners, etc.), and thoroughly mixing these ingredients with the gum base in the same mixer, using an L/D of not more than about 15; and

c) sufficiently completing the entire addition and mixing operation in the same mixer, so that the ingredients exist as a substantially homogeneous chewing gum mass, using a total L/D of not more than about 40.

In an embodiment, it is preferred that the gum base ingredients be completely added and mixed upstream from the remaining chewing gum ingredients, and that the remaining ingredients be completely added downstream for mixing with the already blended gum base. However, the invention also includes those

variations wherein a portion of the gum base ingredients may be added downstream with or after some of the remaining ingredients, and/or wherein a portion of the remaining (non-base) ingredients are added
5 upstream with or before some of the base ingredients.

With the foregoing in mind, it is an advantage of the invention to provide, in an embodiment, a continuous method for manufacturing chewing gum which does not require a separate
10 manufacture of chewing gum base.

It is also an advantage of the invention to provide a mixer that does not overmix the chewing gum ingredients.

It is also an advantage of the invention to
15 provide a method of increasing throughput of the extruder.

It is also an advantage of the invention, in an embodiment, to provide a continuous method for making chewing gum which can accomplish every essential
20 mixing step using a single mixer.

It is also an advantage of the invention to provide a continuous method for making chewing gum which requires less equipment, less capital investment, and less labor than conventional manufacturing methods.

25 It is also an advantage of the invention to provide a continuous manufacturing method that produces chewing gum having greater product consistency, less thermal degradation, less thermal history, and less contamination than chewing gum produced using
30 conventional processes that require longer manufacturing times and more manufacturing steps.

The foregoing and other features and advantages of the invention will become further apparent from the following detailed description of the
35 presently preferred embodiments, read in conjunction with the accompanying examples and drawings. The

detailed description, examples and drawings are intended to be merely illustrative rather than limiting, the scope of the invention being defined by the appended claims and equivalents thereof.

5 **BRIEF DESCRIPTION OF THE DRAWINGS**

Fig. 1 is a perspective view of a Buss high efficiency mixer illustrating a mixing barrel and mixing screw arrangement.

Fig. 2A is a perspective view of an on-screw
10 element used on the upstream side of a restriction ring assembly, in the high efficiency mixer configuration.

Fig. 2B is a perspective view of an on-screw
15 element used on the downstream side of the restriction ring assembly in the high efficiency mixer configuration.

Fig. 2C is a perspective view of a restriction ring assembly used in the high efficiency mixer configuration.

Fig. 3 is a perspective view showing the
20 relative positioning of the elements of Figs. 2A, 2B and 2C in the high efficiency mixer configuration.

Fig. 4 is a perspective view of a low-shear mixing screw element used in the high efficiency mixer configuration.

25 Fig. 5 is a perspective view of a high-shear mixing screw element used in the high efficiency mixer configuration.

Fig. 6 is a perspective view of a barrel pin
30 element used in the high efficiency mixer configuration.

Fig. 7 is a schematic diagram of an arrangement of mixing barrel pins and ingredient feed ports.

Fig. 8 is a schematic diagram of a mixing
35 screw configuration.

DETAILED DESCRIPTION OF THE PRESENTLY PREFERRED EMBODIMENTS

The present invention provides methods for the manufacture of chewing gum. In an embodiment, the present invention provides a method for the total manufacture of chewing gum using a single continuous high-efficiency mixer, without requiring the separate manufacture of chewing gum base. This method can be advantageously performed using a continuous mixer whose mixing screw is composed of precisely arranged mixing elements and conveying elements. An example of a mixer is a blade-and-pin mixer exemplified in Fig. 1. A blade-and-pin mixer uses a combination of selectively configured rotating mixer blades and stationary barrel pins to provide efficient mixing over a relatively short distance. A commercially available blade-and-pin mixer is the Buss kneader, manufactured by Buss AG in Switzerland, and available from Buss America, located in Bloomingdale, Illinois.

Referring to Fig. 1, the blade-and-pin mixer 100 includes a single mixing screw 120 turning inside a barrel 140 which, during use, is generally closed and completely surrounds the mixing screw 120. The mixing screw 120 includes a generally cylindrical shaft 122 and three rows of mixing blades 124 arranged at evenly spaced locations around the screw shaft 122 (with only two of the rows being visible in Fig. 1). The mixing blades 124 protrude radially outward from the shaft 122, with each one resembling the blade of an axe.

As set forth below, and as illustrated in Fig. 8, pursuant to the present invention, the screw shaft 122 of the mixer includes conveyor elements 125. Although generally steps are taken to maximize the mixing efficiency of an extruder to allow the process to be completed in the limited L/D available of the extruder, at certain points in the extruder the mixing

may become excessive. This can adversely effect product quality and reduce volumetric efficiency (throughput). Although a possible solution might be to shorten the L/D at those points, this may not be
5 practical because the distance may be mandated by the distance between addition ports or other uncontrollable aspects of the particular extruder design.

The use of conveyor elements 125, as a substitute for certain of the mixing elements 124, at
10 one or more points along the shaft 122 has been found to reduce overmixing and increase throughput without altering the basic design of the extruder. These conveyor elements 125 are typically helical screws. They can be located at a variety of positions on the
15 screw 122.

Pursuant to the present invention, at least one of the conveyor elements is located in a position that is not directly under an ingredient addition port. As used herein, the term "not directly under" means
20 that no significant portion of the element is adjacent to the port. However, it is acceptable for a small overlap to occur between the element and port, so long as the majority of the element extends beyond the wall of the port.

As illustrated, the mixer 100 includes a mixing barrel 140 that includes an inner barrel housing 142 which is generally cylindrical when the barrel 140 is closed around the screw 120 during operation of the mixer 100. Three rows of stationary pins 144 are
30 arranged at evenly spaced locations around the screw shaft 142, and protrude radially inward from the barrel housing 142. The pins 144 are generally cylindrical in shape, and may have rounded or bevelled ends 146.

In the mixer, the mixing screw 120 with
35 blades 124 rotates inside the barrel 140 and is driven by a variable speed motor (not shown). During

rotation, the mixing screw 120 also moves back and forth in an axial direction, creating a combination of rotational and axial mixing which is highly efficient. During mixing, the mixing blades 124 and conveyor elements 125 continually pass between the stationary pins 144, yet never touch each other. Also, the radial edges 126 of the blades 124 never touch the barrel inner surface 142, and the ends 146 of the pins 144 never touch the mixing screw shaft 122. During rotation, the mixing elements and conveyor elements act on the chewing gum ingredients.

Figs. 2-6 illustrate various screw elements which can be used to configure the mixing screw 120 for optimum use. Figs. 2A and 2B illustrate on-screw elements 20 and 21 which are used in conjunction with a restriction ring assembly. The on-screw elements 20 and 21 each include a cylindrical outer surface 22, a plurality of blades 24 projecting outward from the surface 22, and an inner opening 26 with a keyway 28 for receiving and engaging a mixing screw shaft (not shown). The second on-screw element 21 is about twice as long as the first on-screw element 20.

Fig. 2C illustrates a restriction ring assembly 30 used to build back pressure at selected locations along the mixing screw 120. The restriction ring assembly 30 includes two halves 37 and 39 mounted to the barrel housing 142, which halves engage during use to form a closed ring. The restriction ring assembly 30 includes a circular outer rim 32, an inner ring 34 angled as shown, and an opening 36 in the inner ring which receives, but does not touch, the on-screw elements 20 and 21 mounted to the screw shaft. Mounting openings 35 in the surface 32 of both halves of the restriction ring assembly 30 are used to mount the halves to the barrel housing 142 or 342.

Fig. 3 illustrates the relationship between the restriction ring assembly 30 and the on-screw elements 20 and 21 during operation. When the mixing screw 120 is turning inside the barrel 140, and reciprocating axially, the clearances between the on-screw elements 20 and 21 and the inner ring 34 provide the primary means of passage of material from one side of the restriction ring assembly 30 to the other. The on-screw element 20 on the upstream side of the restriction ring assembly includes a modified blade 27 permitting clearance of the inner ring 34. The other on-screw element 21 is placed generally downstream of the restriction ring assembly 30, and has an end blade (not visible) which moves close to and wipes the opposite surface of the inner ring 34.

The clearances between outer surfaces 22 of the on-screw elements 20 and 21 and the inner ring 34 of the restriction ring assembly 30, which can vary and preferably are on the order of 1-5 mm, determine to a large extent how much pressure build-up will occur in the upstream region of the restriction ring assembly 30 during operation of the mixer 100. It should be noted that the upstream on-screw element 20 has an L/D of about 1/3, and the downstream on-screw element 21 has an L/D of about 2/3, resulting in a total L/D of about 1.0 for the on-screw elements. The restriction ring assembly 30 has a smaller L/D of about 0.45 which coincides with the L/D of the on-screw elements 20 and 21, which engage each other but do not touch the restriction ring assembly.

Figs. 4 and 5 illustrate the mixing or "kneading" elements which perform most of the mixing work. The primary difference between the lower shear mixing element 40 of Fig. 4 and the higher shear mixing element 50 of Fig. 5 is the size of the mixing blades which project outward on the mixing elements. In Fig.

5, the higher shear mixing blades 54 which project outward from the surface 52 are larger and thicker than the lower shear mixing blades 44 projecting outward from the surface 42 in Fig. 4. For each of the mixing elements 40 and 50, the mixing blades are arranged in three circumferentially-spaced rows, as explained above with respect to Fig. 1. The use of thicker mixing blades 54 in Fig. 5 means that there is less axial distance between the blades and also less clearance between the blades 54 and the stationary pins 144 as the screw 120 rotates and reciprocates axially (Fig. 1). This reduction in clearance causes inherently higher shear in the vicinity of the mixing elements 50.

Fig. 6 illustrates a single stationary pin 144 detached from the barrel 140. The pin 144 includes a threaded base 145 which permits attachment at selected locations along the inner barrel shaft 142. It is also possible to configure some of the pins 144 as liquid injection ports by providing them with hollow center openings.

Fig. 7 is a schematic view showing a barrel configuration, including an arrangement of barrel pins 144. Fig. 8 is a corresponding schematic view illustrating a mixing screw configuration. The mixer 200 whose preferred configuration is illustrated in Figs. 7 and 8 has an overall active mixing L/D. of about 20.

The mixer 200 includes an initial feed zone 210 and five mixing zones 220, 230, 240, 250 and 260. The zones 210, 230, 240, 250 and 260 include five possible large feed ports 212, 232, 242, 252 and 262, respectively, which can be used to add major (e.g. solid) ingredients to the mixer 200. The zones 240 and 260 are also configured with five smaller liquid injection ports 241, 243, 261, 263 and 264 which are used to add liquid ingredients. The liquid injection

ports 241, 243, 261, 263 and 264 include special barrel pins 144 formed with hollow centers, as explained above.

Referring to Fig. 7, barrel pins 144 are preferably present in most or all of the available locations, in all three rows as shown.

Referring to Fig. 8, a configuration of the mixing screw 120 is schematically illustrated as follows. Zone 210, which is the initial feed zone, is configured with four low shear and two high shear elements having a total L/D of 4.

A 57 mm restriction ring assembly 30 with cooperating on-screw elements 20 and 21, straddles the end of the first mixing zone 220 and the start of the second mixing zone 230. The assembly and element have a combined L/D of about 1.0, part of which is in the second mixing zone 230. Then, zone 230 is configured, from left to right, with three low shear mixing elements 40 and 1.5 high shear mixing elements 50. The three low shear mixing elements contribute about 2.0 L/D of mixing, and the 1.5 high shear mixing elements contribute about 1.0 L/D of mixing. Zone 230 has a total mixing L/D of about 4.0.

Straddling the end of the second mixing zone 230 and the start of the third mixing zone 240 is a 60mm restriction ring assembly 30 with cooperating on-screw elements 20 and 21 having an L/D of about 1.0. Then, zone 240 is configured, from left to right, with 4.5 high shear mixing elements 50 contributing a mixing L/D of about 3.0. Zone 240 also has a total mixing L/D of about 4.0.

Straddling the end of the third mixing zone 240 and the start of the fourth mixing zone 250 is another 60mm restriction ring assembly 30 with cooperating on-screw elements having an L/D of about 1.0. Then, the remainder of the fourth mixing zone 250

is configured with 5½ low shear mixing elements 40 contributing a mixing L/D of about 4. The fifth mixing zone 260 included, pursuant to the present invention, two conveyor elements having an L/D of 2. This is 5 followed by 2½ low shear elements having a total L/D of 2½. The total screw length was 20½ L/D.

Before explaining where the various chewing gum ingredients are added to the continuous mixer 200, and how they are mixed, it is helpful to discuss the 10 composition of typical chewing gums that can be made using the method of the invention. A chewing gum generally includes a water soluble bulk portion, a water insoluble chewing gum base portion, and one or more flavoring agents. The water soluble portion 15 dissipates over a period of time during chewing. The gum base portion is retained in the mouth throughout the chewing process.

The insoluble gum base generally includes elastomers, elastomer plasticizers (resins), fats, 20 oils, waxes, softeners and inorganic fillers. The elastomers may include polyisobutylene, isobutylene-isoprene copolymer, styrene butadiene copolymer and natural latexes such as chicle. The resins may include polyvinyl acetate and terpene resins. Low molecular 25 weight polyvinyl acetate is a preferred resin. Fats and oils may include animal fats such as lard and tallow, vegetable oils such as soybean and cottonseed oils, hydrogenated and partially hydrogenated vegetable oils, and cocoa butter. Commonly used waxes include 30 petroleum waxes such as paraffin and microcrystalline wax, natural waxes such as beeswax, candellia, carnauba and polyethylene wax.

The gum base typically also includes a filler component such as calcium carbonate, magnesium 35 carbonate, talc, dicalcium phosphate and the like; softeners, including glycerol monostearate and glycerol

triacetate; and optional ingredients such as antioxidants, color and emulsifiers. The gum base constitutes between 5-95% by weight of the chewing gum composition, more typically 10-50% by weight of the chewing gum, and most commonly 20-30% by weight of the chewing gum.

The water soluble portion of the chewing gum may include softeners, bulk sweeteners, high intensity sweeteners, flavoring agents and combinations thereof.

10 Softeners are added to the chewing gum in order to optimize the chewability and mouth feel of the gum. The softeners, which are also known as plasticizers or plasticizing agents, generally constitute between about 0.5-15% by weight of the chewing gum. The softeners
15 may include glycerin, lecithin, and combinations thereof. Aqueous sweetener solutions such as those containing sorbitol, hydrogenated starch hydrolysates, corn syrup and combinations thereof, may also be used as softeners and binding agents in chewing gum.

20 Bulk sweeteners constitute between 5-95% by weight of the chewing gum, more typically 20-80% by weight of the chewing gum and most commonly 30-60% by weight of the chewing gum. Bulk sweeteners may include both sugar and sugarless sweeteners and components.

25 Sugar sweeteners may include saccharide containing components including but not limited to sucrose, dextrose, maltose, dextrin, dried invert sugar, fructose, levulose, galactose, corn syrup solids, and the like, alone or in combination. Sugarless
30 sweeteners include components with sweetening characteristics but are devoid of the commonly known sugars. Sugarless sweeteners include but are not limited to sugar alcohols such as sorbitol, mannitol, xylitol, hydrogenated starch hydrolysates, maltitol,
35 and the like, alone or in combination.

High intensity sweeteners may also be present and are commonly used with sugarless sweeteners. When used, high intensity sweeteners typically constitute between 0.001-5% by weight of the chewing gum, preferably between 0.01-1% by weight of the chewing gum. Typically, high intensity sweeteners are at least 20 times sweeter than sucrose. These may include but are not limited to sucralose, aspartame, salts of acesulfame, alitame, saccharin and its salts, cyclamic acid and its salts, glycyrrhizin, dihydrochalcones, thaumatin, monellin, and the like, alone or in combination.

Combinations of sugar and/or sugarless sweeteners may be used in chewing gum. The sweetener may also function in the chewing gum in whole or in part as a water soluble bulking agent. Additionally, the softener may provide additional sweetness such as with aqueous sugar or alditol solutions.

Flavor should generally be present in the chewing gum in an amount within the range of about 0.1-15% by weight of the chewing gum, preferably between about 0.2-5% by weight of the chewing gum, most preferably between about 0.5-3% by weight of the chewing gum. Flavoring agents may include essential oils, synthetic flavors or mixtures thereof including but not limited to oils derived from plants and fruits such as citrus oils, fruit essences, peppermint oil, spearmint oil, other mint oils, clove oil, oil of wintergreen, anise and the like. Artificial flavoring agents and components may also be used in the flavor ingredient of the invention. Natural and artificial flavoring agents may be combined in any sensorially acceptable fashion.

Optional ingredients such as colors, emulsifiers, pharmaceutical agents and additional flavoring agents may also be included in chewing gum.

In accordance with the invention, the gum base and ultimate chewing gum product are made continuously in the same mixer. Generally, the gum base portion is made using a mixing L/D of about 25 or less, preferably about 20 or less, most preferably about 15 or less. Then, the remaining chewing gum ingredients are combined with the gum base to make a chewing gum product using a mixing L/D of about 15 or less, preferably about 10 or less, most preferably about 5 or less. The mixing of the gum base ingredients and the remaining chewing gum ingredients may occur in different parts of the same mixer or may overlap, so long as the total mixing is achieved using an L/D of about 40 or less, preferably about 30 or less, most preferably about 20 or less.

In a preferred blade-and-pin mixer arrangement, the total chewing gum can be made using a mixing L/D of about 20. The gum base can be made using an L/D of about 15 or less, and the remaining gum ingredients can be combined with the gum base using a further L/D of about 5 or less.

In order to accomplish the total chewing gum manufacture using the blade-and-pin mixer 200, it is advantageous to maintain the rpm of the mixing screw 120 at less than about 150, preferably less than about 125. Also, the mixer temperature is preferably optimized so that the gum base is at about 130°F or lower when it initially meets the other chewing gum ingredients, and the chewing gum product is at about 130°F or lower (preferably 125°F or lower) when it exits the mixer. This temperature optimization can be accomplished, in part, by selectively heating and/or water cooling the barrel sections surrounding the mixing zones 220, 230, 240, 250 and 260.

In order to manufacture the gum base, the following procedure can be followed. The elastomer,

filler, and at least some of the elastomer solvent are added to the first large feed port 212 in the feed zone 210 of the mixer 200, and are subjected to highly dispersive mixing in the first mixing zone 220 while being conveyed in the direction of the arrow 122. The remaining elastomer solvent (if any) and polyvinyl acetate are added to the second large feed port 232 in the second mixing zone 230, and the ingredients are subjected to a more distributive mixing in the remainder of the mixing zone 230.

Fats, oils, waxes (if used), emulsifiers and, optionally, colors and antioxidants, are added to the liquid injection ports 241 and 243 in the third mixing zone 240, and the ingredients are subjected to distributive mixing in the mixing zone 240 while being conveyed in the direction of the arrow 122. At this point, the gum base manufacture should be complete, and the gum base should leave the third mixing zone 240 as a substantially homogeneous, lump-free compound with a uniform color.

The fourth mixing zone 250 is used primarily to cool the gum base, although minor ingredient addition may be accomplished. Then, to manufacture the final chewing gum product, glycerin, corn syrup, other bulk sugar sweeteners, high intensity sweeteners, and flavors can be added to the fifth mixing zone 260, and the ingredients are subjected to distributive mixing. If the gum product is to be sugarless, hydrogenated starch hydrolyzate or sorbitol solution can be substituted for the corn syrup and powdered alditols can be substituted for the sugars.

Preferably, glycerin is added to the first liquid injection port 261 in the fifth mixing zone 260. Solid ingredients (bulk sweeteners, encapsulated high intensity sweeteners, etc.) are added to the large feed port 262. Syrups (corn syrup, hydrogenated starch

hydrolyzate, sorbitol solution, etc.) are added to the next liquid injection port 263, and flavors are added to the final liquid injection port 264. Flavors can alternatively be added at ports 261 and 263 in order to help plasticize the gum base, thereby reducing the temperature and torque on the screw. This may permit running of the mixer at higher rpm and throughput.

The gum ingredients are compounded to a homogeneous mass which is discharged from the mixer as a continuous stream or "rope". The continuous stream or rope can be deposited onto a moving conveyor and carried to a forming station, where the gum is shaped into the desired form such as by pressing it into sheets, scoring, and cutting into sticks. Because the entire gum manufacturing process is integrated into a single continuous mixer, there is less variation in the product, and the product is cleaner and more stable due to its simplified mechanical and thermal histories.

A wide range of changes and modifications to the preferred embodiments of the invention will be apparent to persons skilled in the art. The above preferred embodiments, and the examples which follow, are merely illustrative of the invention and should not be construed as imposing limitations on the invention. For instance, different continuous mixing equipment and different mixer configurations can be used without departing from the invention as long as the preparation of a chewing gum base and chewing gum product are accomplished in a single continuous mixer using a mixing L/D of not more than about 40.

Example 1: Testing The Suitability
Of A Continuous Mixer

The following preliminary test can be employed to determine whether a particular continuous mixer with a particular configuration meets the

requirements of a high efficiency mixer suitable for practicing the method of the invention.

A dry blend of 35.7% butyl rubber (98.5% isobutylene - 1.5% isoprene copolymer, with a molecular weight of 120,000-150,000, manufactured by Polysar, Ltd. of Sarnia, Ontario, Canada as POLYSAR Butyl 101-3); 35.7% calcium carbonate (VICRON 15-15 from Pfizer, Inc., New York, New York); 14.3% polyterpene resin (ZONAREZ 90 from Arizona Chemical Company of Panama City, Florida) and 14.3% of a second polyterpene resin (ZONAREZ 7125 from Arizona Chemical Company) is fed into the continuous mixer in question equipped with the mixer configuration to be tested. The temperature profile is optimized for the best mixing, subject to the restriction that the exit temperature of the mixture does not exceed 170°C (and preferably remains below 160°C) to prevent thermal degradation. In order to qualify as a suitable high efficiency mixer, the mixer should produce a substantially homogeneous, lump-free compound with a uniform milky color in not more than about 10 L/D, preferably not more than about 7 L/D, most preferably not more than about 5 L/D.

To thoroughly check for lumps, the finished rubber compound may be stretched and observed visually, or compressed in a hydraulic press and observed, or melted on a hot plate, or made into a finished gum base which is then tested for lumps using conventional methods.

Also, the mixer must have sufficient length to complete the manufacture of the gum base, and of the chewing gum product, in a single mixer, using a total mixing L/D of not more than about 40. Any mixer which meets these requirements falls within the definition of a high-efficiency mixer suitable for practicing the method of the invention.

Examples 2-11: Continuous Chewing Gum Manufacture

The following examples were run using a Buss kneader with a 100mm mixer screw diameter, configured in the preferred manner described above (unless indicated otherwise), with five mixing zones, a total mixing L/D of 19, and an initial conveying L/D of 1-1/3. No die was used at the end of the mixer, unless indicated otherwise, and the product mixture exited as a continuous rope. Each example was designed with feed rates to yield chewing gum product at the rate of 300 pounds per hour.

Liquid ingredients were fed using volumetric pumps into the large feed ports and/or smaller liquid injection ports generally positioned as described above, unless otherwise indicated. The pumps were appropriately sized and adjusted to achieve the desired feed rates.

Dry ingredients were added using gravimetric screw feeders into the large addition ports positioned as described above. Again, the feeders were appropriately sized and adjusted to achieve the desired feed rates.

Temperature control was accomplished by circulating fluids through jackets surrounding each mixing barrel zone and inside the mixing screw. Water cooling was used where temperatures did not exceed 200°F, and oil cooling was used at higher temperatures. Where water cooling was desired, tap water (typically at about 57°F) was used without additional chilling.

Temperatures were recorded for both the fluid and the ingredient mixture. Fluid temperatures were set for each barrel mixing zone (corresponding to zones 220, 230, 240, 250 and 260 in Figs. 7 and 8), and are reported below as Z1, Z2, Z3, Z4 and Z5, respectively. Fluid temperatures were also set for the mixing screw 120, and are reported below as S1.

Actual mixture temperatures were recorded near the downstream end of mixing zones 220, 230, 240 and 250; near the middle of mixing zone 260; and near the end of mixing zone 260. These mixture temperatures are reported below as T1, T2, T3, T4, T5 and T6, respectively. Actual mixture temperatures are influenced by the temperatures of the circulating fluid, the heat exchange properties of the mixture and surrounding barrel, and the mechanical heating from the mixing process, and often differ from the set temperatures due to the additional factors.

All ingredients were added to the continuous mixer at ambient temperature (about 77°F) unless otherwise noted.

15 Example 2

This example illustrates the preparation of a spearmint flavored non-tack sugar chewing gum. A mixture of 24.2% terpene resin, 29.7% dusted ground butyl rubber (75% rubber with 25% fine ground calcium carbonate as an anti-blocking aid) and 46.1% fine ground calcium carbonate was fed at 25 lb/hr into the first large feed port (port 212 in Figs. 7 and 8). Low molecular weight polyisobutylene (mol. wt. = 12,000), preheated to 100°C, was also added at 6.3 lb/hr into this port.

Ground low molecular weight polyvinyl acetate was added at 13.3 lb/hr into the second large feed port (port 232 in Figs. 7 and 8).

A fat mixture, preheated to 83°C, was injected into the liquid injection ports in the third mixing zone (ports 241 and 243 in Fig. 7), at a total rate of 18.4 lb/hr, with 50% of the mixture being fed through each port. The fat mixture included 30.4% hydrogenated soybean oil, 35.4% hydrogenated cottonseed

oil, 13.6% partially hydrogenated soybean oil, 18.6% glycerol monostearate, 1.7% cocoa powder, and 0.2% BHT.

Glycerin was injected into the first liquid injection port in the fifth mixing zone (port 261 in Fig. 7) at 3.9 lb/hr. A mixture of 1.1% sorbitol and 98.9% sugar was added into the large feed port in the fifth mixing zone (port 262 in Fig. 7) at 185.7 lb/hr. Corn syrup, preheated to 44°C, was added into the second liquid injection port in the fifth mixing zone (port 263 in Fig. 7) at 44.4 lb/hr. Spearmint flavor was added into the third liquid injection port in the fifth mixing zone (port 264 in Fig. 7) at 3.0 lb/hr.

The zone temperatures Z1-Z5 were set (in °F) at 350, 350, 150, 57 and 57, respectively. The mixing screw temperature S1 was set at 120°F. The mixture temperatures T1-T6 were measured at steady state (in °F) as 235, 209, 177, 101 and 100, and fluctuated slightly during the trial. The screw rotation was 80 rpm.

20 The chewing gum product exited the mixer at 120°F. The product was comparable to that produced by conventional pilot scale batch processing. The chew was slightly rubbery but no base lumps were visible.

Example 3

25 This example illustrates the preparation of a peppermint flavored non-tack sugar chewing gum. A dry mixture of 57% dusted ground butyl rubber (75% rubber, 25% calcium carbonate) and 43% fine ground calcium carbonate was added at the first large feed port 212 (Fig. 7), at 13.9 lb/hr. Molten polyisobutylene 30 (preheated to 100°C) was also added to port 212 at 9.5 lb/hr.

Ground low molecular weight polyvinyl acetate was added to port 232 at 13.0 lb/hr.

A fat mixture (preheated to 82°C) was pumped 50/50 into ports 241 and 243 at a total rate of 23.6 lb/hr. The fat mixture included 33.6% hydrogenated cottonseed oil, 33.6% hydrogenated soybean oil, 24.9% 5 partially hydrogenated soybean oil, 6.6% glycerol monostearate, 1.3% cocoa powder and 0.1% BHT. Glycerin was added to port 261 at 2.1 lb/hr. A mixture of 98.6% sugar and 1.4% sorbitol was added to port 262 at 196 lb/hr. Corn syrup (preheated to 40°C) was added 10 to port 263 at 39.9 lb/hr. Peppermint flavor was added to port 264 at 2.1 lb/hr.

The zone temperatures (Z1-Z5, °F) were set at 350, 350, 300, 60 and 60, respectively. The screw temperature (S1) was set at 200°F. The mixture 15 temperatures (T1-T6, °F) were measured as 297, 228, 258, 122, 98 and 106, respectively. The screw rotation was 85 rpm.

The chewing gum product exited the mixer at 119°F. The finished product was free of lumps but was 20 dry and lacked tensile strength. These defects were attributed to the formula rather than the processing.

Example 4

This example illustrates the preparation of a spearmint flavored gum for pellet coating. A blend of 25 27.4% high molecular weight terpene resin, 26.9% low molecular weight terpene resin, 28.6% dusted ground butyl rubber (75% rubber, 25% calcium carbonate) and 17.1% fine ground calcium carbonate was fed into the first large port 212 (Fig. 7), at 33.5 lb/hr. Molten 30 polyisobutylene (100°C) was pumped into the same port at 1.3 lb/hr.

Low molecular weight polyvinyl acetate was fed to port 232 at 19.8 lb/hr.

A fat mixture (82°C) was added 50/50 into 35 ports 241 and 243, at a total rate of 17.4 lb/hr. The

fat mixture included 22.6% hydrogenated cottonseed oil, 21.0% partially hydrogenated soybean oil, 21.0% hydrogenated soybean oil, 19.9% glycerol monostearate, 15.4% lecithin and 0.2% BHT.

5 Sugar was fed into port 262 at 157.8 lb/hr. Corn syrup (40°C) was added to port 263 at 68.4 lb/hr. Spearmint flavor was added to port 264 at 1.8 lb/hr.

The zone temperatures (Z1-Z5, °F) were set at 160, 160, 110, 60 and 60, respectively. The screw
10 temperature (S1) was set at 68°F. The mixture temperatures (T1-T6, °F) were measured as 230, 215, 166, 105, 109 and 111, respectively. The screw rotation was 80 rpm.

The chewing gum product exited the mixer at
15 121°F. The product was firm and cohesive when chewed (normal for a pellet center). No base lumps were visible.

Example 5

This example illustrates the preparation of a
20 peppermint flavored sugar chewing gum. A blend of 24.4% dusted ground butyl rubber (75% rubber, 25% calcium carbonate), 18.0% low molecular weight terpene resin, 18.3% high molecular weight terpene resin and 39.4% fine ground calcium carbonate was added to the
25 first large port 212 (Fig. 7) at 27.6 lb/hr.

A blend of 11.1% high molecular weight polyvinyl acetate and 88.9% low molecular weight polyvinyl acetate was added into the second large feed port 232 at 14.4 lb/hr. Polyisobutylène (preheated to
30 100°C) was also added to this port at 3.5 lb/hr.

A fat mixture (83°C) was added 50/50 into ports 241 and 243, at a total rate of 14.5 lb/hr. This fat mixture included 31.9% hydrogenated cottonseed oil, 18.7% hydrogenated soybean oil, 13.2% partially
35 hydrogenated cottonseed oil, 19.8% glycerol

monostearate, 13.7% soy lecithin, 2.5% cocoa powder and 0.2% BHT.

Glycerin was injected into port 261 at 3.9 lb/hr. A mixture of 84.6% sucrose and 15.4% dextrose monohydrate was added to port 262 at 203.1 lb/hr. Corn syrup (40°C) was injected into port 263 at 30.0 lb/hr. A mixture of 90% peppermint flavor and 10% soy lecithin was injected into port 264 at 3.0 lb/hr.

The zone temperatures (Z1-Z5, °F) were set at 350, 350, 100, 60 and 60, respectively, and the screw temperature (S1) was set at 100°F. The mixture temperatures (T1-T6, °F) were measured as 308, 261, 154, 95, 94 and 105, respectively. The screw rotation was set at 55 rpm.

The product exited the mixer at 127°F. The finished product had good chew characteristics and there was no evidence of rubber lumps.

Example 6

This example illustrates the preparation of a fruit-flavored sugar gum. A mixture of 39.3% dusted ground butyl rubber (75% rubber, 25% calcium carbonate), 39.1% low molecular weight terpene resin and 21.6% fine ground calcium carbonate was added to the first large feed port 212 (Fig. 7) at 20.6 lb/hr.

A mixture of 33.0% low molecular weight terpene resin and 67.0% low molecular weight polyvinyl acetate was added at 24.4 lb/hr into the second large feed port 232. Polyisobutylene (preheated to 100°C) was also added at 1.0 lb/hr into the port 232.

A fat/wax composition (82°C) was injected 50/50 into the liquid injection ports 241 and 243, at a total rate of 14.0 lb/hr. The composition included 29.7% paraffin wax, 21.7% microcrystalline wax (m.p. = 170°F), 5.7% microcrystalline wax (m.p. = 180°F), 20.5% glycerol monostearate, 8.6% hydrogenated cottonseed

oil, 11.4% soy lecithin, 2.1% cocoa powder, and 0.3% BHT.

Glycerin was injected into the liquid injection port 261 at 3.3 lb/hr. A mixture of 88.5% sucrose and 11.5% dextrose monohydrate was added at 201.0 lb/hr into the large port 262. Corn syrup (40°C) was injected at 3.0 lb/hr into the liquid injection port 263, and a mixture of 88.9% fruit flavor and 11.1% soy lecithin was injected at 2.7 lb/hr into the liquid injection port 264.

The zone temperatures (Z1-Z5, °F) were set at 425, 425, 200, 61 and 61, respectively. The screw temperature (S1) was set at 66°F. The mixture temperatures (T1-T6, °F) were measured as 359, 278, 185, 105, 100 and 109, respectively. The screw rotation was set at 70 rpm.

The chewing gum product exited the mixer at 122°F. The product was very soft while warm and fell apart during chewing. However, this was not atypical for this product. After aging for two months, the product was again chewed and found to have excellent texture and flavor. No rubber lumps were visible.

Example 7

This example illustrates the preparation of a sugar chunk bubble gum. For this example, the mixer configuration was varied slightly from the preferred configuration described above and used for Examples 2-6. Specifically, a round-hole 30mm die was installed at the exit end of the mixer.

A blend of 68.9% high molecular weight polyvinyl acetate and 31.1% ground talc was added into the first large feed port 212 (Fig. 7), at 35.4 lb/hr. Polyisobutylene (preheated to 100°C) was also added to port 212 at 3.95 lb/hr. Further downstream, in the first mixing zone 220, acetylated monoglyceride was

injected at 2.6 lb/hr, using a liquid injection (hollow barrel pin) port not shown in Fig. 7.

Additional polyisobutylene (100°C) at 3.95 lb/hr, and glycerol ester of partially hydrogenated wood rosin at 13.4 lb/hr, were added into the second large port 232. A mixture of 43.6% glycerol monostearate, 55.9% triacetin and 0.5% BHT was added at 6.7 lb/hr into the liquid injection port 241.

Glycerin was injected at 2.1 lb/hr into the liquid injection port 261. A mixture of 98.4% sucrose and 1.6% citric acid was added at 170.4 lb/hr into the large port 262. Corn syrup (40°C) was injected at 58.5 lb/hr into liquid injection port 263, and a mixture of 60% lemon-lime flavor and 40% soy lecithin was added at 3.0 lb/hr into the liquid injection port 264.

The zone temperatures (Z1-Z5, °F) were ultimately set at 440, 440, 160, 61 and 61, respectively. The screw temperature (S1) was ultimately set at 80°F. The mixture temperatures (T1-T6, °F) were ultimately measured as 189, 176, 161, 97, 108 and 112, respectively. The screw rotation was 55 rpm.

At first, the product exited the extruder at 140°F and exhibited signs of heat stress. The zone temperatures Z1 and Z2 were then reduced by 10°F each, and the screw temperature S1 was raised by 20°F, to the values shown above. This caused the chewing gum exit temperature to drop to 122°F, and the product quality improved markedly.

During chewing, the product exhibited excellent texture, flavor, and bubble blowing characteristics. No rubber lumps were visible.

Example 8

This example illustrates the preparation of a spearmint flavored sugarless gum. A mixture of 42.1%

fine ground calcium carbonate, 18.9% glycerol ester of wood rosin, 16.7% glycerol ester of partially hydrogenated wood rosin, 17.0% ground butyl rubber, and 5.3% dusted ground (25:75) styrene butadiene rubber
5 (75% rubber, 25% calcium carbonate) was added into port 212 (Fig. 7) at 38.4 lb/hr.

Low molecular weight polyvinyl acetate at 12.7 lb/hr, and polyisobutylene (preheated to 100°C) at 7.6 lb/hr, were added into port 232.

10 A fat mixture (82°C) was injected 50/50 into ports 241 and 243, at a total rate of 20.9 lb/hr. The fat mixture included 35.7% hydrogenated cottonseed oil, 30.7% hydrogenated soybean oil, 20.6% partially hydrogenated soybean oil, 12.8% glycerol monostearate
15 and 0.2% BHT.

Unlike the previous examples, glycerin was injected at 25.5 lb/hr into the fourth mixing zone 250 (Fig. 7) through a liquid injection port (not shown). A coevaporated blend of hydrogenated starch hydrolysate
20 and glycerin (at 40°C) was injected further downstream in the fourth mixing zone 250 through another liquid injection port (not shown). The coevaporated blend included 67.5% hydrogenated starch hydrolysate solids, 25% glycerin and 7.5% water.

25 A mixture of 84.8% sorbitol, 14.8% mannitol and 0.4% encapsulated aspartame was added into port 262 in the fifth mixing zone 260, at 162.3 lb/hr. A mixture of 94.1% spearmint flavor and 5.9% lecithin was injected at 5.1 lb/hr into the port 264 located further
30 downstream.

The zone temperatures (Z1-Z5, °F) were set at 400, 400, 150, 62 and 62, respectively. The screw temperature (S1) was set at 66°F. The mixture temperatures (T1-T6, °F) were measured as 307, 271,
35 202, 118, 103 and 116. The mixing screw rotation was 69 rpm.

The chewing gum product exited the mixer at 117°F. The gum had good appearance with no sorbitol spots or rubber lumps. The gum was slightly wet to the touch, sticky and fluffy (low density), but was acceptable. During chewing, the gum was considered soft initially but firmed up with continued chewing.

Example 9

This example illustrates the preparation of a sugarless spearmint gum for use in coated pellets. A mixture of 28.6% dusted ground butyl rubber (75% rubber, 25% calcium carbonate), 27.4% high molecular weight terpene resin, 26.9% low molecular weight terpene resin and 17.1% calcium carbonate was added into port 212 (Fig. 7) at 41.9 lb/hr.

Low molecular weight polyvinyl acetate at 24.7 lb/hr, and polyisobutylene (preheated to 100°C) at 1.7 lb/hr, were added into port 232.

A fat composition (82°C) was injected 50/50 into ports 241 and 243 at a total rate of 21.7 lb/hr. The fat composition included 22.6% hydrogenated cottonseed oil, 21.0% hydrogenated soybean oil, 21.0% partially hydrogenated soybean oil, 19.9% glycerol monostearate, 15.4% glycerin and 0.2% BHT.

A 70% sorbitol solution was injected into the fourth mixing zone 250 (Fig. 7) at 17.4 lb/hr, using a hollow barrel pin liquid injection port (not shown).

A mixture of 65.8% sorbitol, 17.9% precipitated calcium carbonate and 16.3% mannitol was added at 184.2 lb/hr into the final large port 262. A mixture of 71.4% spearmint flavor and 28.6% soy lecithin was added at 8.4 lb/hr into the final liquid injection port 264.

The zone temperatures (Z1-Z5, °F) were set at 400, 400, 150, 61 and 61, respectively. The screw temperature (S1) was set at 65°F. The mixture

temperatures (T1-T6, °F) were measured as 315, 280, 183, 104, 109 and 116, respectively. The screw rotation was set at 61 rpm.

The chewing gum exited the mixer at 127°F.
5 The product appearance was good with no sorbitol spots or rubber lumps. However, the initial chew was reported as being rough and grainy.

Example 10

This example illustrates the preparation of a
10 peppermint flavored sugar chewing gum. A mixture of 27.4% dusted ground butyl rubber (75% butyl rubber dusted with 25% calcium carbonate), 14.1% lower softening terpene resin (softening point = 85°C), 14.4%
15 higher softening terpene resin (softening point = 125°C) and 44.1% calcium carbonate was fed at 24.6 lb/hr into the first large feed port (port 212 in Figs. 7 and 8).

20 A mixture of 73.5% low molecular weight polyvinyl acetate, 9.2% high molecular weight polyvinyl acetate, 8.6 lower softening terpene resin and 8.7% higher softening terpene resin was fed at 17.4 lb/hr into the second large feed port 232. Polyisobutylene was also added at 3.5 lb/hr into this port.

25 A fat mixture, preheated to 83°C, was injected into the liquid injection ports in the third mixing zone (ports 241 and 243 in Fig. 7), at a total rate of 14.5 lb/hr, with 50% of the mixture being fed through each port. The fat mixture included 0.2% BHT, 2.5% cocoa powder, 31.9% hydrogenated cottonseed oil,
30 19.8% glycerol monostearate, 18.7% hydrogenated soybean oil, 13.7% lecithin, and 13.2% partially hydrogenated cottonseed oil.

A mixture of 84.6% sugar and 15.4% dextrose monohydrate was injected at 203.1 lb/hr into the large
35 feed port 262 in the fifth mixing zone. Glycerin was

added at 3.9 lb/hr into the first liquid injection port 261 in the fifth mixing zone. Corn syrup, preheated to 44°C, was added at 30.0 lb/hr into the second liquid injection port 263 in the fifth mixing zone. A mixture
5 of 90.0% peppermint flavor and 10.0% lecithin was injected into the third liquid injection port 264 in the fifth mixing zone at 3.0 lb/hr.

The zone temperatures Z1-Z5 were set (in °F) at 350, 350, 110, 25 and 25, respectively. The mixing
10 screw temperature S1 was set at 101°F. The mixer temperatures T1-T6 were measured at steady state (in °F) as 320, 280, 164, 122, 105 and 103, respectively. The screw rotation was 63 rpm, and the product exited the mixer at 52-53°C.

15 The peppermint sugar gum product was desirably soft, and acceptable in quality.

Example 11

This example illustrates the preparation of a sugarless stick bubble gum. For this example, the
20 screw configuration shown in Fig. 8, and used for the previous examples, was varied as follows. The conveying section 210 and mixing sections 220, 250 and 260 were configured substantially as before. In the second mixing zone 230, the three low shear elements 40
25 were also not changed.

Thereafter, the 1-1/2 high shear elements 50 in zone 230, the restriction element 30 overlapping zones 230 and 240, all of zone 240, and the restriction element 30 overlapping zones 240 and 250 were removed.
30 Three high shear elements 50 (combined L/D = 2.0) were placed in zone 230 and extended into zone 240. Two and one-half low shear elements 40 (combined L/D = 1-2/3) followed in zone 240. Then, three and one-half high shear elements 50 (combined L/D = 2-1/3) followed in
35 zone 240 and extended into zone 250. The eleven low-

shear elements 40 in zones 250 and 260 were not changed.

To make the product, a mixture of 53.3% high molecular weight polyvinyl acetate, 31.0% talc, 12.2% glycerol ester of wood rosin and 3.5% dusted ground (25:75) styrene-butadiene rubber (75% rubber, 25% calcium carbonate) were fed into the large port 212 (Fig. 7) at 54.9 lb/hr. Polyisobutylene (preheated to 100°C) was pumped into the same port at 9.0 lb/hr.

Glycerol ester of partially hydrogenated wood rosin at 15.3 lb/hr, and triacetin at 4.4 lb/hr, were added into the large port 232 in the second mixing zone 230.

A fat/wax mixture (at 82°C) was fed 50/50 into the liquid injection ports 241 and 243 in the third mixing zone 240, at a total rate of 13.9 lb/hr. The mixture included 50.3% glycerol monostearate, 49.4% paraffin (m.p. = 135°F) and 0.3% BHT.

Diluted glycerin was injected into the fourth mixing zone 250 at 28.2 lb/hr using a liquid injection port (not shown). The dilution was 87% glycerin and 13% water.

A mixture of 84.0% sorbitol, 12.7% mannitol, 1.1% fumaric acid, 0.2% aspartame, 0.4% encapsulated aspartame, 0.7% adipic acid and 0.9% citric acid was fed into port 262 in the fifth mixing zone 260 at 165.0 lb/hr. A mixture of 51.6% bubble gum flavor and 48.4% soy lecithin was injected into port 264 in zone 260 at 9.3 lb/hr.

The zone temperatures (Z1-Z5, °F) were set at 350, 350, 100, 64 and 64, respectively. The screw temperature (S1) was set at 100°F. The mixture temperatures (T1-T6, °F) were recorded as 286, 260, 163, 107, 104 and 112, respectively. The screw rotation was 75 rpm.

The chewing gum exited the mixer at 118°F. The finished product looked good and contained no base lumps. The flavor and texture were very good during chewing, as were the bubble blowing characteristics.

5 Examples 12-14, by way of example, and not limitation, illustrate an embodiment of the present invention using conveyor elements.

Example 12

Several premix compositions were prepared to
10 simplify the mixing process.

Rubber Blend

Three parts butyl rubber were ground with one part calcium carbonate. 35.611% of the ground mixture was dry blended with 55.746% calcium carbonate and
15 8.643% Glycerol Ester of Hydrogenated Rosin.

Polyvinyl Acetate Blend

43.618% low molecular weight PVAc was dry blended with 10.673% Glycerol Ester of Polymerized Rosin and 45.709% Glycerol Ester of Hydrogenated Rosin.

20 Fat Blend

The following ingredients were melted and blended:

	7.992%	Hydrogenated Soybean Oil
	13.712%	Hydrogenated Cottonseed Oil
25	12.199%	Glycerol Monostearate
	37.070%	Paraffin Wax
	28.851%	Microcrystalline Wax
	0.176%	BHT

Corn Syrup/Glycerin Blend

30 93.713% 45.5 Baume corn syrup was heated and blended with 6.287% glycerin.

Sugar/Color Blend

10% of a glycerin slurry of red lake was mixed with 90% sugar in a Hobart mixer. The resulting
35 product was a damp powder which could be fed into the extruder with a twin screw volumetric feeder.

To the first port were added the Rubber Blend (34.67 lbs/hr) and Molten Polyisobutylene (5.80 lbs/hr).

5 Into the second port was added the Polyvinyl Acetate Blend at 24.98 lbs/hr.

Molten Fat Blend was injected in equal portions through two injection pins in section 3 at a total rate of 26.98 lbs/hr.

10 Heated Corn Syrup/Glycerin Blend was injected through a pin located at the beginning of Section 5 at a rate of 78.92 lbs/hr.

Sugar was added into port 5 at a rate of 283.15 lbs/hr along with the sugar/color blend at 13.87 lbs/hr.

15 Finally, cinnamon flavor was injected near the end of section 5 at a rate of 6.62 lbs/hr.

This produced a total output of approximately 475 lbs/hr from the extruder.

20 The zone temperatures (Z_1 and Z_5 in °F) were set to 350, 250, 150, 55 and 55. The screw was heated to 150°F.

The screw was configured as follows:

25 In the first barrel section, four low shear then two high shear elements having a total L/D of 4 were fitted to the screw shaft. Straddling the end of the first section and the beginning of the second was a 57 mm restriction ring which, along with its on-screw hardware, had a L/D of 1.

30 In the second section, three low shear elements then 1½ high shear elements having a total L/D of 3 were fitted. Straddling the end of the second section and beginning of the third was a 60 mm restriction ring (1 L/D).

35 The third section was fitted 4½ high shear elements (3 L/D). A 60 mm restriction ring (1 L/D) straddled the third and fourth sections.

The fourth section was fitted with six low shear elements (4 L/D) the last of which extended into the fifth section.

5 The fifth section was fitted with a conveyor element adjacent to the ingredient addition port and having an L/D of 1. This was followed by 3½ low shear elements having a total L/D of 2½. The total screw length was 20½ L/D.

10 With this configuration, it was necessary to operate the screw at 125 rpm in order to prevent a backup of sugar in the fifth intake port. The finished gum exited at 129°F. Both the screw speed and the exit temperature were considered excessive.

Example 13

15 The screw profile in Example 12 was then altered by adding a second conveyor element immediately after the first in the fifth section. In order to accommodate the new element, a half low shear element was substituted for one of the full elements just prior
20 to the first conveyor element and another low shear element after the conveyor elements was eliminated.

25 Otherwise, this run was identical to Example 12. However, it was found that a screw speed of 110 rpm was sufficient to prevent backup in the sugar feed port. The exit temperature was reduced to 123°F. Both of these values were considered acceptable. The finished product was also acceptable.

Example 14

30 Although the run described in Example 13 was generally acceptable, there was a minor problem with unincorporated sugar as evidenced by an occasional puff of sugar dust from the extruder discharge. Although this problem was believed to be due to poor performance of the sugar feeder, it was remedied by the following
35 changes.

A low shear half element in Section 4 was removed. The two conveyor elements were moved upstream to fill the gap created by removal of the half element. An additional low shear half element was added after the conveyor elements to increase mixing. The corn syrup/glycerin blend injection point was moved to a pin located after Port 5.

The screw speed was reduced to 109 rpm. The finished product exited at 122°F.

10 In summary, the foregoing examples indicate that the method of the invention can be used to prepare a wide variety of good quality chewing gum products in a single continuous mixer, without requiring the separate manufacture of gum base in a different mixer. 15 This method is expected to save manufacturing time and money, and improve the product consistency and quality.

It should be appreciated that the method of the present invention is capable of being incorporated in the form of a variety of embodiments, only a few of 20 which have been illustrated and described above. The invention may be embodied in other forms without departing from its spirit or essential characteristics. It will be appreciated that the addition of certain other ingredients, process steps, materials or 25 components not specifically included will have an adverse impact on the present invention. The best mode of the invention may therefore exclude ingredients, process steps, materials or components other than those listed above for inclusion or use in the invention.

30 However, the described embodiments are to be considered in all respects only as illustrative and not restrictive, and the scope of the invention is, therefore, indicated by the appended claims rather than by the foregoing description. All changes which come 35 within the meaning and range of equivalency of the claims are to be embraced within their scope.

~~WE CLAIM:~~

~~The~~ claims defining the invention are as follows:

1. A method of manufacturing chewing gum comprising the steps of adding chewing gum ingredients to a high efficiency continuous mixer that includes a conveyor element on a screw of the mixer at a location that is not directly under an ingredient addition port.

2. The method of Claim 1 wherein the high efficiency continuous mixer includes at least one additional conveyor element located directly under an ingredient addition port.

3. The method of Claim 1 wherein gum base is also manufactured in the high efficiency continuous mixer.

4. The method of Claim 1 wherein finished gum base is added to the high efficiency continuous mixer.

5. The chewing gum product manufacturing according to the method of Claim 1.

6. A method of continuously manufacturing chewing gum without requiring separate manufacture of a chewing gum base, comprising the steps of:

a) adding at least an elastomer and filler into a high efficiency continuous mixer, and mixing the elastomer and filler together in the continuous mixer;

b) adding at least one ingredient selected from the group consisting of fats, oils, waxes and elastomer plasticizers into the continuous mixer, and mixing said ingredient with the elastomer and filler in the continuous mixer;

c) adding at least one sweetener and at least one flavor into the continuous mixer, and mixing said sweetener and flavor with the remaining ingredients to form a chewing gum product; and

d) wherein after one of the ingredients is added to the mixer, it is subjected to a conveyor element on a screw of a single high efficiency continuous mixer,

the conveyor element being located at a position that is not directly under an ingredient addition port.

7. The method of Claim 6, wherein steps a)-c) are performed using a mixing L/D of not more than about 40.

8. The method of Claim 6, wherein steps a)-c) are performed using a total mixing L/D of not more than about 30.

9. The method of Claim 6 wherein the high efficiency continuous mixer includes at least one additional conveyor element located directly under an ingredient addition port.

10. A chewing gum product manufactured according to the method of Claim 6.

11. A method of continuously manufacturing chewing gum comprising the steps of:

a) adding gum base into a high efficiency continuous mixer that includes feed ports, mixing elements and at least one conveyor element that is not located directly under a feed port;

b) adding at least one sweetener and at least one flavoring agent into the gum base in the continuous mixer;

c) subjecting at least the sweetener, flavoring agent, and gum base to distributive mixing in the continuous mixer, to form a chewing gum product; and

d) continuously discharging the chewing gum product from the mixer.

12. The method of Claim 11 wherein at least one conveyor element is located directly under an ingredient feed port.

13. A chewing gum product manufactured according to the method of Claim 11.

14. The method of Claim 11 wherein the base is added to the mixer as finished base.

15. The method of Claim 11 wherein the base is manufactured in the mixer.

16. A method of continuously manufacturing chewing gum comprising the steps of:

a) adding a gum base into a blade-and-pin mixer;

b) adding at least one sweetener and at least one flavor into the blade-and-pin mixer, and mixing said sweetener and flavor with the remaining ingredients to form a chewing gum product; and

c) wherein the mixer includes at least one conveyor element that is not located directly under a feed port of the mixer.

17. The method of Claim 16 wherein at least one conveyor element is located directly under an ingredient feed port.

18. A chewing gum product manufactured according to the method of Claim 16.

19. The method of Claim 16 wherein the gum base is added to the mixer as finished gum base.

20. The method of Claim 16 wherein the gum base is manufactured in the mixer.

DATED this THIRTEENTH day of SEPTEMBER 1995
Wm. Wrigley Jr. Company

Patent Attorneys for the Applicant
SPRUSON & FERGUSON

Chewing Gum Manufacture Using High Efficiency
Continuous Mixer

ABSTRACT

A method is provided for the total manufacture of chewing gum on a continuous basis. The method uses a continuous high efficiency mixer (100) which includes at least one conveyor element (125) that is not located under a feed port (212,232,242,252,262).

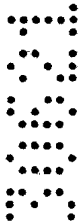

FIG. 1

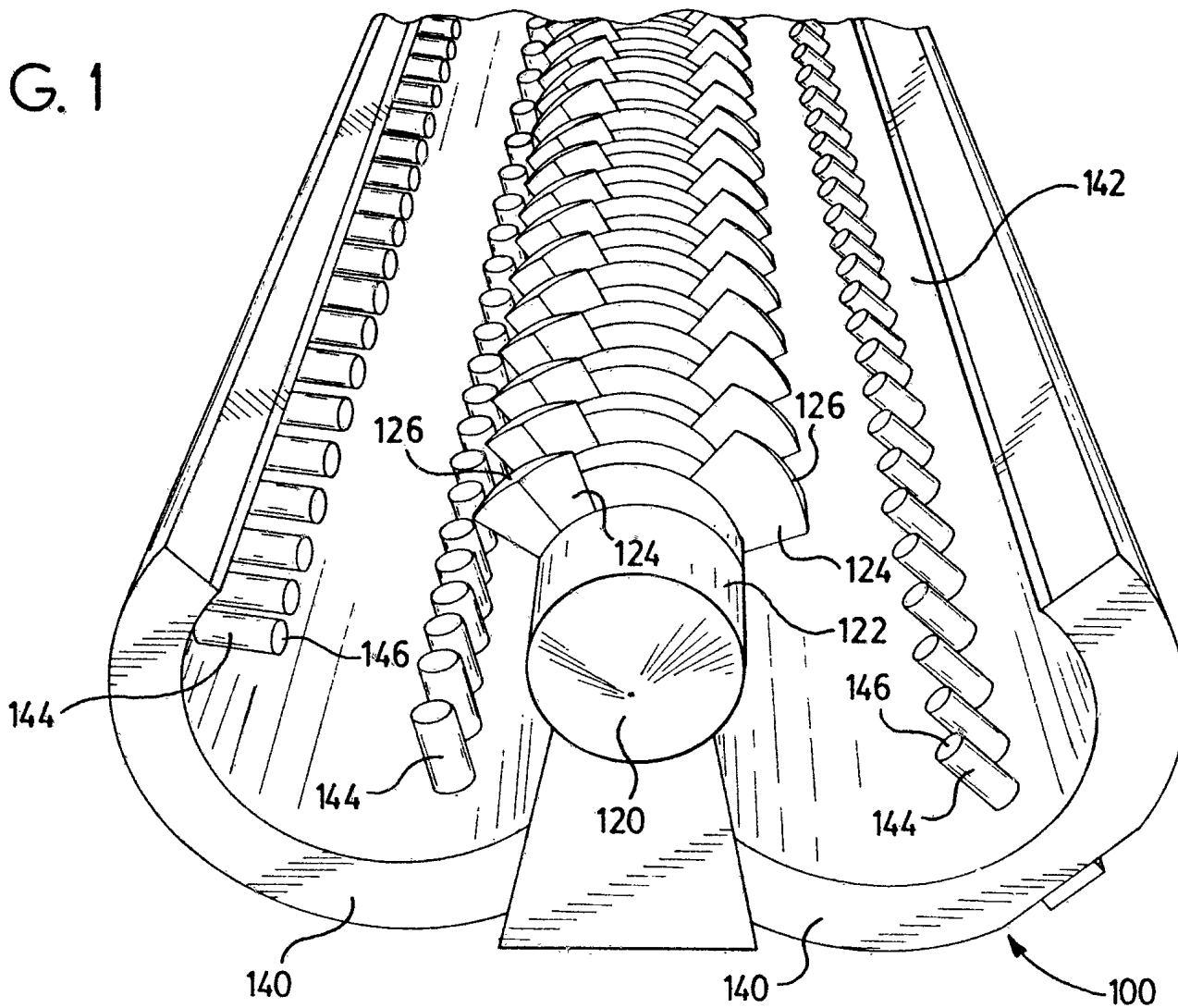

FIG.2A

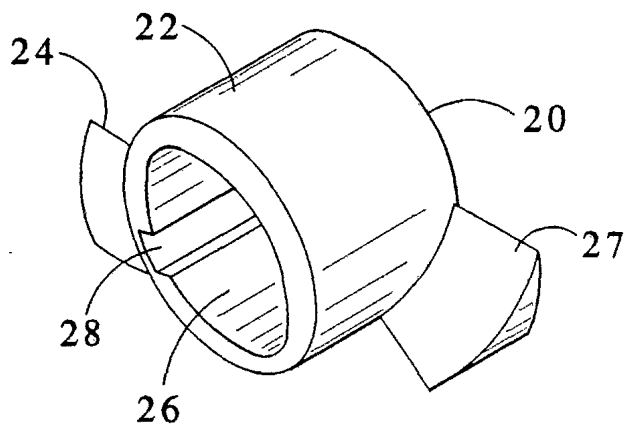

FIG.2B

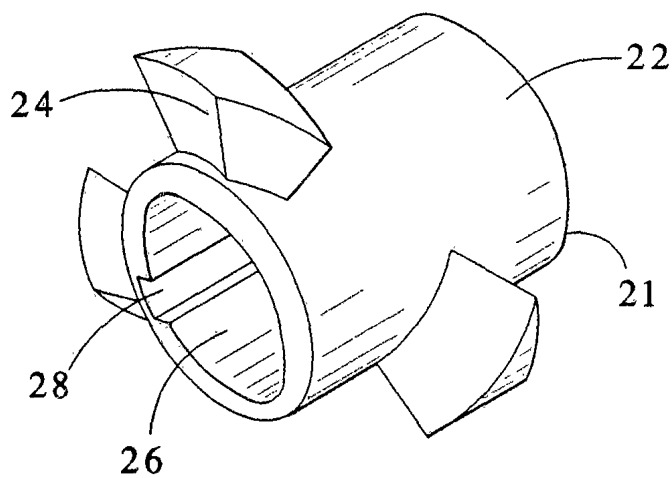

FIG.2C

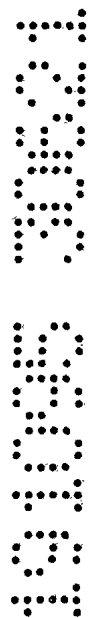
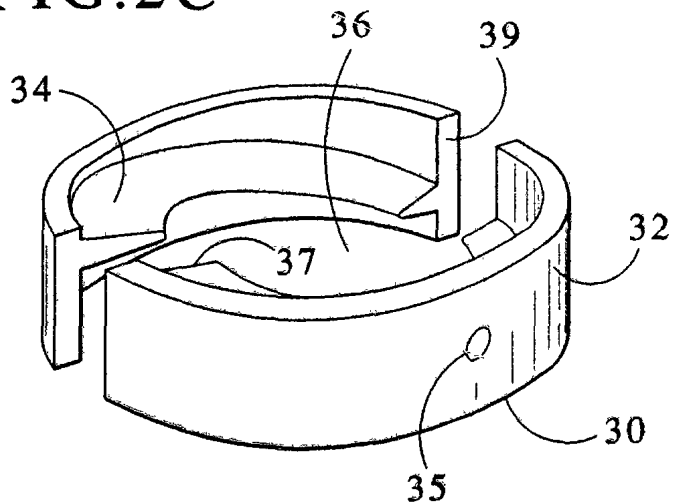

FIG.3

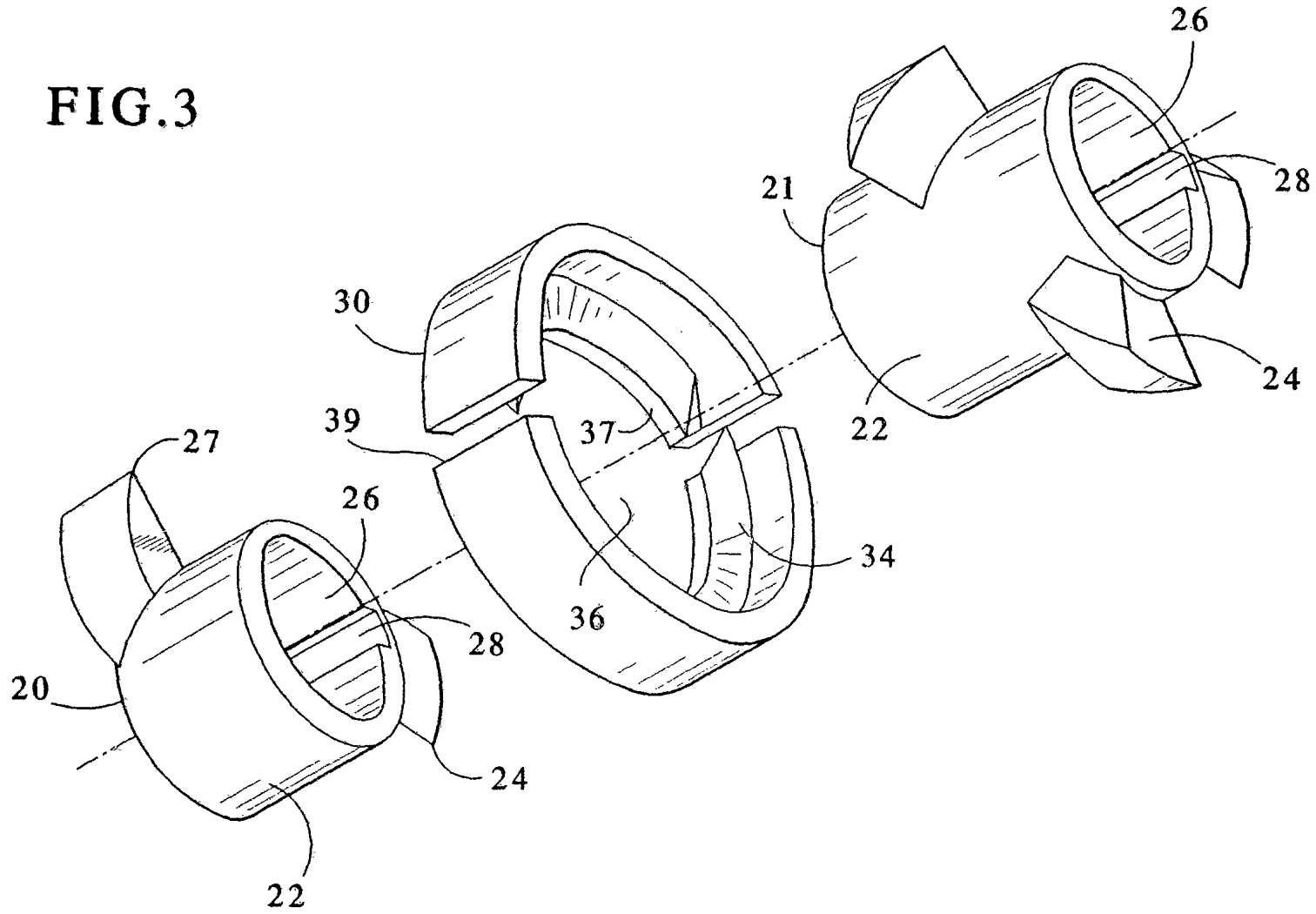

FIG. 4

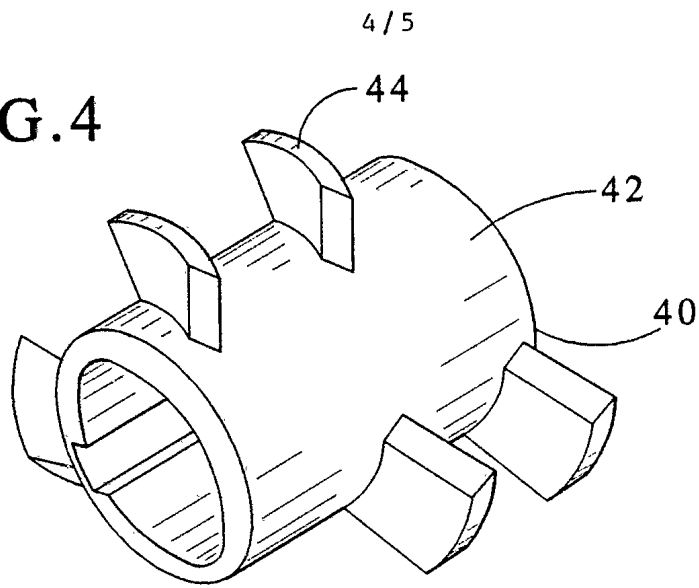

FIG. 5

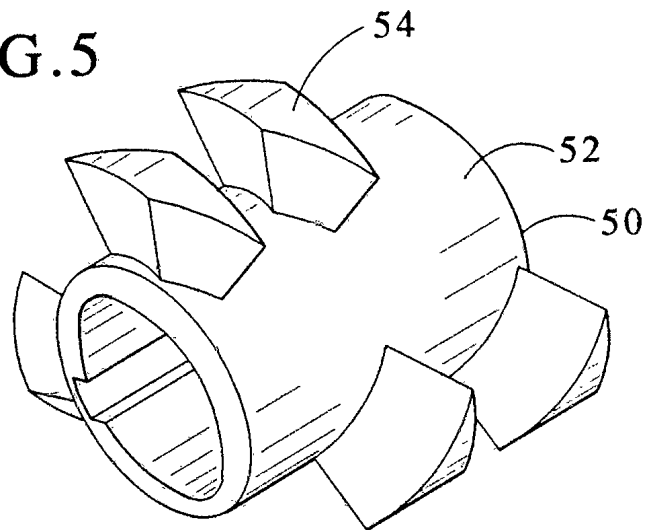

FIG. 6

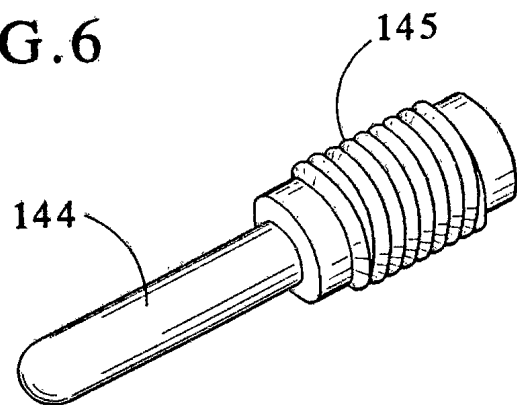

FIG. 7

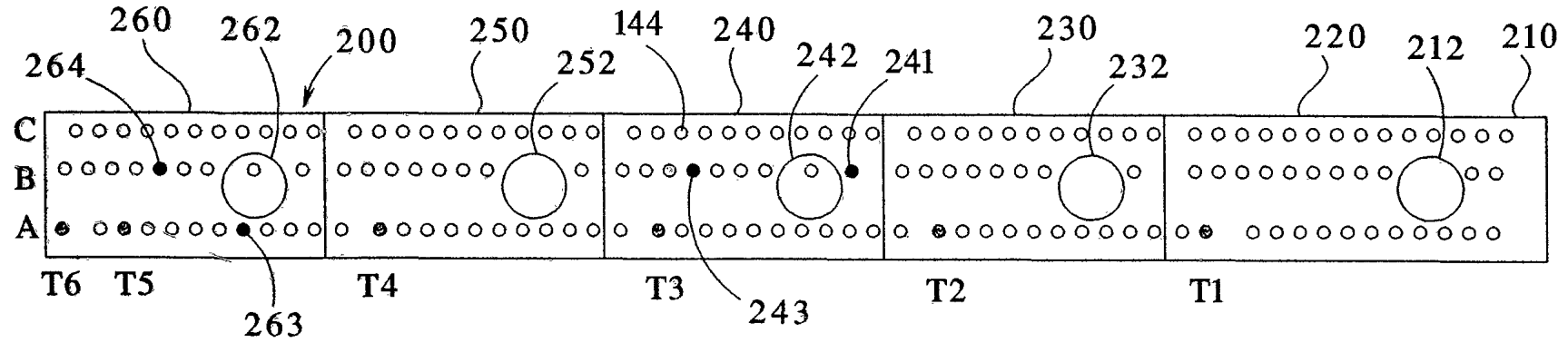

FIG. 8

