

(19) World Intellectual Property Organization
International Bureau



(43) International Publication Date
5 December 2002 (05.12.2002)

PCT

(10) International Publication Number
WO 02/098066 A2

- (51) International Patent Classification⁷: **H04L 12/56**
- (21) International Application Number: PCT/CA02/00810
- (22) International Filing Date: 31 May 2002 (31.05.2002)
- (25) Filing Language: English
- (26) Publication Language: English
- (30) Priority Data:

09/870,767	1 June 2001 (01.06.2001)	US
09/870,766	1 June 2001 (01.06.2001)	US
09/870,800	1 June 2001 (01.06.2001)	US
09/870,703	1 June 2001 (01.06.2001)	US
09/870,841	1 June 2001 (01.06.2001)	US

- (72) Inventors; and
- (75) Inventors/Applicants (for US only): **NORMAN, Richard, S.** [US/CA]; 1877 Poissant Road, Sutton, Quebec JOE 2K0 (CA). **DE MARIA, Marcelo** [BR/CA]; 575 Lucien l'Allier, Apt. 504, Montreal, Quebec H3C 4L3 (CA). **COTE, Sébastien** [CA/CA]; 181 Boulanger, St-Bruno, Quebec J3V 2C2 (CA). **LANGLOIS, Carl** [CA/CA]; 6630-23rd Avenue, Montreal, Quebec H1T 4C1 (CA). **HAUGHEY, John** [US/US]; 94 Corliss Road, Richford, VT 05476 (US). **BOUDREAU, Yves** [CA/CA]; 99 Holland Avenue, Apt. 401, Ottawa, Ontario K1Y 0Y1 (CA).

(71) Applicant (for all designated States except US): **HYPER-CHIP INC.** [CA/CA]; 1800 René-Lévesque Ouest, Montréal, Québec H3H 2H2 (CA).

(74) Agents: **GEORGIEV, Stephan, P.** et al.; Smart & Biggar, Suite 3400, 1000 de la Gauchetière Street West, Montreal, Quebec H3B 4W5 (CA).

(81) Designated States (national): AE, AG, AL, AM, AT, AU, AZ, BA, BB, BG, BR, BY, BZ, CA, CH, CN, CO, CR, CU,

[Continued on next page]

(54) Title: CELL-BASED SWITCH FABRIC ARCHITECTURE

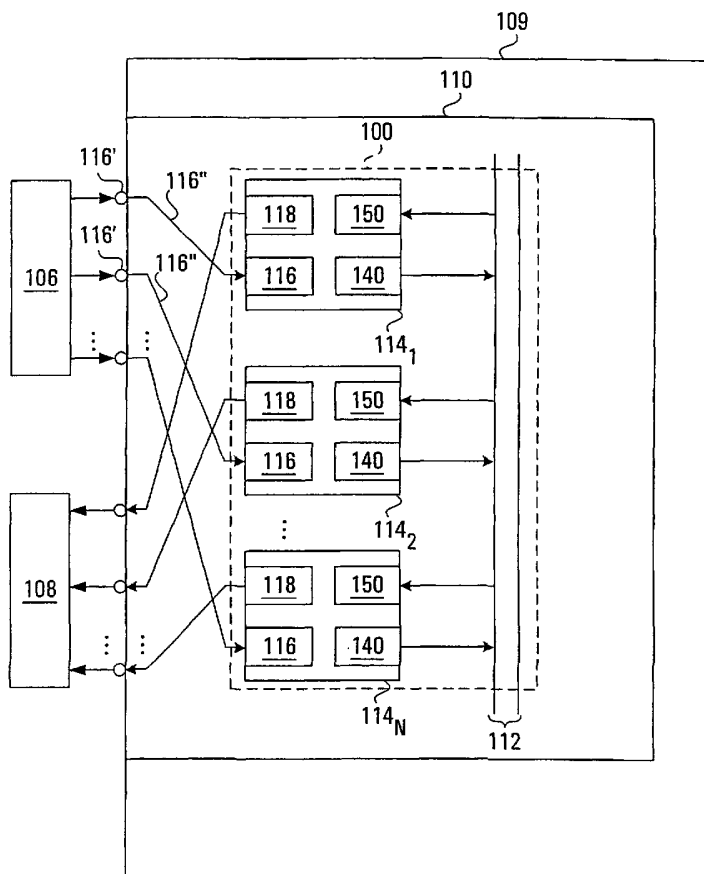

(57) Abstract: A switch fabric implemented on a chip includes an array of cells and an I/O interface in communication with the cells for permitting exchange of data packet between the cells and components external thereto. Each cell includes a transmitter in communication with the I/O interface and in communication with every other cell of the array, the transmitter being operative to process a data packet received from the I/O interface to determine a destination of the packet and forward it to at least one cell of the array selected on a basis of the determined destination. Each cell further includes plural receivers associated with respective cells from the array, each receiver being in communication with a respective cell allowing the respective cell to forward data packets to the receiver, where the receivers are in communication with the I/O interface for releasing data packets thereto. In this way, the transmitter in a given cell functionally extends into those cells where dedicated receivers are located, reducing transmitter memory requirements and allowing the switch fabric to be implemented on a single chip.

WO 02/098066 A2



CZ, DE, DK, DM, DZ, EC, EE, ES, FI, GB, GD, GE, GH, GM, HR, HU, ID, IL, IN, IS, JP, KE, KG, KP, KR, KZ, LC, LK, LR, LS, LT, LU, LV, MA, MD, MG, MK, MN, MW, MX, MZ, NO, NZ, OM, PH, PL, PT, RO, RU, SD, SE, SG, SI, SK, SL, TJ, TM, TN, TR, TT, TZ, UA, UG, US, UZ, VN, YU, ZA, ZM, ZW.

(84) Designated States (regional): ARIPO patent (GH, GM, KE, LS, MW, MZ, SD, SL, SZ, TZ, UG, ZM, ZW), Eurasian patent (AM, AZ, BY, KG, KZ, MD, RU, TJ, TM), European patent (AT, BE, CH, CY, DE, DK, ES, FI, FR, GB, GR, IE, IT, LU, MC, NL, PT, SE, TR), OAPI patent (BF, BJ, CF, CG, CI, CM, GA, GN, GQ, GW, ML, MR, NE, SN, TD, TG).

Declarations under Rule 4.17:

- *as to applicant's entitlement to apply for and be granted a patent (Rule 4.17(ii)) for all designations*
- *as to the applicant's entitlement to claim the priority of the earlier application (Rule 4.17(iii)) for all designations*
- *of inventorship (Rule 4.17(iv)) for US only*

Published:

- *without international search report and to be republished upon receipt of that report*

For two-letter codes and other abbreviations, refer to the "Guidance Notes on Codes and Abbreviations" appearing at the beginning of each regular issue of the PCT Gazette.

CELL-BASED SWITCH FABRIC ARCHITECTURE

FIELD OF THE INVENTION

5

The present invention relates generally to the switching of packets and, more particularly, to a high capacity switch fabric that can be implemented on a single semiconductor substrate.

10 BACKGROUND OF THE INVENTION

In a networking environment, it is necessary to route information groups (usually referred to as "packets") between hosts along determined paths through the network. A routing algorithm is performed by the hosts in the network in order to
15 determine the path to be followed by packets having various combinations of source and destination host. A path typically consists of a number of "hops" through the network, each such hop designating a host with a capacity to continue forwarding the packet along the determined path. The outcome of the routing algorithm thus depends on the state and topology of the network.

20

Often, each packet has a protocol address and a label switch address. The protocol address identifies the destination host, while the label switch address identifies the host to which the packet is to be transmitted via the next "hop". As a
25 packet travels from the source and is redirected by hosts located at different hops along the determined path, its label switch address is modified but its protocol address remains unchanged.

To achieve the required functionality, each host typically comprises a device known as a router, which has a routing layer for performing several basic
30 functions for each received packet, including determining a routing path through the network and modifying the label switch address of the packet according to the determined routing path. The router also has a switching layer for switching the packet according to its new label switch address.

The switching layer may be implemented by a packet switch forming part of the router. The packet switch commonly includes a plurality of input ports for receiving streams of packets, a switch fabric for switching each packet according to a local switch address and a plurality of output ports connected to the switch fabric and also connected to adjacent hosts in the network.

Thus, upon receipt of a packet, the router analyzes the packet's protocol address or label switch address, calculates a local switch address and sends the packet to an input port of the packet switch. The packet switch then examines the label switch address of the packet and forwards the packet to the corresponding output port which leads to the next hop, and so on. Often, a new label switch address is applied at each hop.

It is common to provide a buffer at each input port of the packet switch for temporarily storing packets during the time it takes the router to determine the identity of the next hop and during the time it takes the packet switch to send the packet to the appropriate output port.

However, packet switches face problems inherent to the random nature of packet traffic. A first problematic situation may arise when two packets with different destination output ports arrive at the same input port of the switch. For example, let the destination output port of the first-arriving packet be blocked but let the destination output port of the second-arriving packet be available. If the packets are restricted to being transmitted in order of their arrival, then neither packet will be transmitted, at least until the destination output port associated with the first-arriving packet becomes free.

This problem can be solved by providing a mechanism for transmitting packets in a different order from the one in which they arrive. This is commonly referred to in the art as "scheduling" and is performed by a scheduling processor in a central location, since decisions taken with regard to the transmission of packets to a given output port will affect the availability of that output port and will therefore

affect the decisions taken with regard to the transmission of packets to that output port from other input ports.

5 Unfortunately, the centralized nature of the scheduling operation disadvantageously limits the throughput of the switch as the data rate increases, since the scheduler in the packet switch will usually be unable to keep up with the task of timely scheduling multiple packet streams at high data rates.

10 A second problematic situation, known as "contention", arises when two or more packets from different input ports are destined for the same output port at the same time. If an attempt is made to transmit both packets at the same time or within the duration of a packet interval, then either one or both packets will be lost or corrupted. Clearly, if lossless transmission is to be achieved, it is necessary to provide some form of contention resolution.

15 Accordingly, a packet switch can be designed so as to select which input port will be allowed to transmit its packet to the common destination output port. The selected input port will be given permission to transmit its packet to the destination output port while the other packets remain temporarily "stalled" in their respective
20 buffers. This is commonly referred to in the art as "arbitration" and is performed by a processor in a central location, since decisions taken with regard to the transmission of packets from input port A affect the throughput at the output ports, which affects the decisions taken with regard to the transmission of packets from input port B.

25 However, the centralized nature of arbitration again disadvantageously limits the throughput of the switch as the data rate increases, since the arbiter in the packet switch will not be able to keep up with a large number of packet streams at high data rates.

30 As the size and capacity of a switch increases, so does the complexity of the scheduling and arbitration. This increase in complexity of the scheduling and arbitration entails an increase in latency, which consequently increases the

memory requirement. As a result, traditional approaches to scheduling and contention resolution have yielded packet switch designs that require large buffer sizes and complex, centralized scheduling and arbitration circuitry.

5 These properties make it impractical to lithograph a traditionally designed high-performance packet switch with a reasonable number of input and output ports onto a single semiconductor chip using available technology. For this reason, traditional solutions have been implemented on multiple chips and therefore suffer from other problems such as high power consumption, high packaging costs,
10 exposure to electromagnetic interference and significant inefficiencies and cost penalties related to mass production.

As the required switching capacity of packet switches increases to 10^{12} bits per second and beyond, traditional packet switches will be forced to further increase
15 their memory size and complexity, with an associated exacerbation of the problems inherent to a multichip design.

SUMMARY OF THE INVENTION

20 The present invention provides a compact and efficient switch fabric with distributed scheduling, arbitration and buffering, as well as a relatively low requirement for memory, allowing the switch fabric to be implemented on a single mass-producible semiconductor chip.

25 Therefore, according to a first broad aspect, the invention may be summarized as a switch fabric implemented on a chip, including an array of cells and an I/O interface in communication with the array of cells for permitting exchange of data packets between the array of cells and components external to the array of cells. Each cell includes a transmitter in communication with the I/O interface and in
30 communication with every other cell of the array, the transmitter being operative to process a data packet received from the I/O interface to determine a destination of the data packet and forward the data packet to at least one cell of the array selected on a basis of the determined destination.

Each cell further includes a plurality of receivers associated with respective cells from the array, each receiver being in communication with a respective cell allowing the respective cell to forward data packets to the receiver, where the receivers are in communication with the I/O interface for releasing data packets to the I/O interface. In this way, the transmitter in a given cell functionally extends into those cells where dedicated receivers are located, reducing transmitter memory requirements and allowing the switch fabric to be implemented on a single chip.

According to a second broad aspect, the invention may be summarized as a switch fabric implemented on a chip, including an array of cells and an I/O interface in communication with the array of cells for permitting exchange of data packets between said array of cells and components external to said array of cells. Each cell communicates with at least one other cell of the array, thereby permitting an exchange of data packets to take place between the cells of the array. Each cell includes a memory for receiving a data packet from another cell of the array as well as a control entity to control release of a data packet toward a selected destination cell of the array at least in part on a basis of a degree of occupancy of the memory in the destination cell. In this way, scheduling is distributed amongst the cells of the switch fabric.

According to a third broad aspect, the invention may be summarized as a switch fabric implemented on a chip, including an array of cells and an I/O interface in communication with the array of cells permitting exchange of data packets between the array of cells and components external to the array of cells. Each cell communicates with at least one other cell of the array, thereby permitting exchange of data packets between the cells of the array.

Each cell includes a memory for holding a plurality of data packets for transmission to other cells of said array. Each data packet of the plurality of data packets has a characteristic element represented by a parameter, the parameter allowing one data packet to be distinguished from another data packet in the

plurality of data packets. Each cell further includes a control entity operative to select at least one data packet from the plurality of data packets at least in part on a basis of the parameter and to transmit the selected data packet to another cell of said array of cells. In this way, arbitration is distributed throughout the cells of the switch fabric.

According to a fourth broad aspect, the invention may be summarized as a switch fabric implemented on a chip, including an array of cells and an I/O interface in communication with the array of cells for permitting exchange of data packets between the array of cells and components external to the array of cells. Each cell communicates with at least one other cell of the array, permitting an exchange of data packets between the cells of the array and an exchange of control information between the cells of the array. Each cell is operative to control transmission of data packets to other cells of the array at least in part on a basis of the control information. The control information is thus used to regulate the flow of data packets between cells.

According to a fifth broad aspect, the invention may be summarized as a router, including a routing layer and a switching layer. The routing layer includes a plurality of I/O ports for exchanging data with components external to the router. The switching layer is adapted to switch data packets between I/O ports of the routing layer. The switching layer includes an array of cells in communication with the routing layer for permitting exchange of data packets between the array of cells and the routing layer. Each cell includes a memory for receiving a data packet from the routing layer. The routing layer includes a controller to control release of a data packet toward a cell of the array at least in part on a basis of a degree of occupancy of the memory in the cell.

According to a sixth broad aspect, the invention provides a switch fabric implemented on a chip, including an array of cells and an I/O interface in communication with the array of cells for permitting exchange of data packets between the array of cells and components external to the array of cells. Each cell communicates with at least one other cell of the array permitting exchange of

data packets between the cells of the array. Each cell includes a memory for receiving a data packet from the I/O interface and a control signal path for transporting a control signal to a component external to the array of cells, the control signal being indicative of a degree of occupancy of the memory.

5

The invention may be summarized according to a seventh broad aspect as a router, including a routing layer and a switching layer. The routing layer includes a plurality of I/O ports for exchanging data with components external to the router. The switching layer is in communication with the routing layer in order to switch data packets between I/O ports of the routing layer. The routing layer includes a controller responsive to reception of a control signal containing information indicating that the switching layer is capable of accepting a data packet, to release a data packet to the switching layer.

15 These and other aspects and features of the present invention will now become apparent to those of ordinary skill in the art upon review of the following description of specific embodiments of the invention in conjunction with the accompanying drawings.

20 BRIEF DESCRIPTION OF THE DRAWINGS

In the accompanying drawings:

Fig. 1 shows, in schematic form, a switch fabric formed by an interconnection of cells, in accordance with an embodiment of the present invention;

Fig. 2 shows, in schematic form, functional modules of a cell of the switch fabric in Fig. 1, including a transmitter, a plurality of receivers and an arbiter;

30 Fig. 3 shows the format of a packet used in the switch fabric of Fig. 1;

Fig. 4 shows, in schematic form, the arbiter of Fig. 2;

Fig. 5 shows, in schematic form, a receiver of Fig. 2;

Fig. 6 shows, in schematic form, an arrangement of functional modules used in the administration of an aging policy with respect to packets stored in the receiver of Fig. 5; and

Fig. 7 shows, in schematic form, the transmitter of Fig. 2;

Fig. 8 is a flowchart representing the operational steps executed by the queue controller of Fig. 6 in administering the aging policy;

Fig. 9 shows, in schematic form, the transmitter of Fig. 2 adapted to provide multicast functionality;

Figs. 10-12 show, in schematic form, other embodiments of the switch fabric formed by an interconnection of cells;

Fig. 13 shows a packet switch that utilizes multiple switch cards, each containing a switch fabric in accordance with the present invention;

Fig. 14 shows, in schematic form, a cell adapted to provide transmission of system packets to and from a central processing unit;

Fig. 15 shows potential path that may be taken by system packets and traffic packets through the cell of Fig. 14;

Fig. 16 shows, in schematic form, the transmitter of Fig. 14;

Figs. 17A and 17B show, in schematic form, a receiver of Fig. 14;

Fig. 18 shows the format of a system packet used in the cell of Fig. 14;

Fig. 19 shows, in schematic form, yet another embodiment of the switch fabric formed by an interconnection of cells; and

5 Fig. 20 shows interaction between a packet-forwarding module, an input interface and an output interface in accordance with an embodiment of the invention.

DETAILED DESCRIPTION OF THE PREFERRED EMBODIMENTS

10 With reference to Fig. 13, there is shown a packet switch 105, comprising one or more line cards 106, 108, also referred to in the art as tributary cards. The line cards 106, 108 are connected at one end to a core network 107 or to other packet switches or routers. The line cards 106, 108 are connected at another end to one or more switch cards 109. Line cards 106 receive packets from the core network 107 and transmit them to the switch cards 109, while line cards 108 receive
15 switched packets from the switch cards 109 and transmit them to the core network 107. In many embodiments, the line cards 106 are bi-directional. A mid-plane (not shown) may be provided to facilitate interconnection between the line cards 106, 108 and the switch card(s) 109.

20 Each switch card 109 has a plurality of input ports and a plurality of output ports. From the point of view of an individual switch card 109, the line cards 106 are input line cards as they supply packets to the input ports of the switch card 109, while the line cards 108 are output line cards as they receive packets from the output ports of the switch card 109. The function of a switch card 109 is to send
25 each packet received at one of its input ports to an output port specified by or within the packet itself. In this sense, a switch card 109 exhibits self-routing functionality. To provide this functionality, in a preferred embodiment, the switch card 109 comprises a semiconductor substrate (or "wafer" or "chip") 110 on which resides a self-routing switch fabric. In some embodiments, the chip 110 may be a
30 CMOS silicon chip to balance memory density, logic speed and development cost, but other embodiments need not be limited to CMOS, to silicon, to semiconductors or even to electronics.

It should be understood that the term "switch fabric" has a meaning not restricted to traditional routing and/or packet switching applications but extends to cover other applications where a signal path is required to be established, either temporarily or permanently, between a sender and a receiver.

5

Fig. 1 shows a switch fabric 100 in accordance with an embodiment of the present invention, comprising N "cells" 114_j, $1 \leq j \leq N$, implemented on a single chip 110 within a switch card 109. As will be appreciated from the remainder of the specification, a "cell" is an entity that performs processing on a data packet. The processing may be switching of the data packet or another type of processing.

10

The cells 114 are equipped with an input/output (I/O) interface for interfacing with an off-chip environment. The I/O interface refers globally to the functional element of the cell that allows it to communicate with the external world, in one example this world being the off-chip line cards 106. In the illustrated embodiment, each cell 114 includes an input interface 116 for receiving packets from one or more of the input line cards 106 and an output interface 118 for providing switched packets to one or more of the output line cards 108. In other examples, the I/O interface may be the collection of individual I/O ports on the cell.

15

20

In the illustrated non-limiting embodiment, the input interface 116 is connected to pins on the chip 110, which pins are connected to traces 116" on the line card 109, which traces 116" connect to line cards 106 through a releasable connector 116'. But the traces 116" need not be contained or embedded within the switch card 109 and need not be electronic; for example, in embodiments where indium phosphide based switch fabrics are contemplated, guided or free-space optical inputs and outputs may be preferred.

25

In addition, the cells 114 are each equipped with one or more transmitters 140 and one or more receivers 150. Communication between the transmitters and receivers in different cells is achieved by way of a predetermined interconnect pattern 112 which includes "forward" channels and "reverse" (or "back") channels.

30

The forward channels are arranged in such a way as to allow the transmitter 140 in a given cell to send packets to dedicated receivers 150 in its own cell and/or in one or more other cells. Conversely, each receiver 150 in a given cell is dedicated to receiving packets from the transmitter 140, either in its own cell or in one of the other cells, via the appropriate forward channel. Thus, it can be said that a transmitter functionally extends into those cells where its dedicated receivers are located, the end result being that a transmitter on a given cell need not compete with other transmitters on other cells when sending a packet. The back channels include dedicated connections which transport control information from a particular receiver to the associated transmitter from which it receives packets along the forward channel. The individual transmitters in different cells are functionally independent.

The interconnect pattern 112 defines one or more arrays of cells. As used herein, the word "array" is meant to designate the set of cells that are connected to one another. Therefore, a chip may have a plurality of arrays, in the instance where interconnections are such that each cell does not communicate directly with every other cell. The most basic form of array is two cells connected to one another.

In one embodiment of the present invention, the interconnect pattern 112 allows each cell to transmit data to, receive data from, and access control information from, itself and every other cell of the switch fabric 100. Fig. 10 illustrates this feature in the case where $N=4$, and where each cell has a single transmitter 140 and $N=4$ receivers 150. It can be observed that receiver 150_j in cell 114_j is a loopback receiver which receives packets sent by the transmitter 140 in cell 114_j . Fig. 19 shows the same logical interconnect pattern 112 as in Fig. 10, i.e., each cell transmits data to, receives data from, and accesses control information from, itself and every other cell of the switch fabric 100; however, $N=16$ and the cells are arranged physically in a 4×4 matrix. For simplicity, only the forward channels are shown.

With reference to Fig. 11, there is shown an alternative interconnect pattern 112 in which there are provided sixteen cells, each having two transmitters 140_A , 140_B

and eight receivers 150. The sixteen cells 114 are arranged in a square matrix formation, whereby the transmitter 140_A belonging to each cell located in a given row is connected to a receiver in each other cell located in the same row and the transmitter 140_B belonging to each cell located in a given column is connected to a receiver in each other cell located in the same column. The fact that there is one transmitter for eight receivers facilitates scaling to larger numbers of cells. In this case, there are two loopback receivers per cell, although embodiments in which there is only one loopback receiver or no loopback receiver are also within the scope of the present invention.

Although the cells 114 on the chip 110 can be made structurally and functionally identical to one another in order to simplify the overall chip design, this is not a requirement. For example, Fig. 12 partially shows yet another possible interconnect pattern within the scope of the present invention, wherein asymmetry among cells or among groups of cells is incorporated into the design. As illustrated, there are provided sixteen cells 114, again arranged in a matrix formation, each with a single transmitter 140 and one or more receivers 150. The structure of the interconnect of Fig. 12 is "tree"-like in nature, which may be advantageous under certain circumstances. Specifically, the tree-like structure consists of several interlinked arrays of cells. In one array, cell #1 is adapted to transmit packets to cells #2, #3, #4, #5, #6, #7, #8, #9, #10, #11 and #13, while in the other array, cell #7 is adapted to transmit packets to cells #5, #6, #8, #9, #10, #11, #12, #13, #14, #15 and #16. For simplicity, Fig. 12 shows only the connections enabling the transmission from cell #1 and cell #7.

Still other interconnect patterns may be designed without departing from the spirit of the invention. For example, in one embodiment of an Nx1 switch fabric, the cells may be physically implemented as an N/2 by 2 array as this provides an advantageous balance between the simpler wiring of an Nx1 physical implementation and the shorter wiring of a $\sqrt{N} \times \sqrt{N}$ physical implementation. In another embodiment, it is possible to create a three-dimensional array (or "cube") of cells and also to provide one or more of the cells with multiple transmitters.

A wide variety of interconnect patterns would then be possible within such a structure. For instance, in a design employing 8 x 8 x 8 cells, each cell would be designed so as to contain three transmitters (one for the "column", one for the "row" and one for the "line"), as well as 24 receivers, one for each of the cells in the same column, row or line as the cell in question. If the cells are also connected in a diagonal fashion, the number of transmitters and receivers will differ amongst the cells. For example, the cell at the center of the cube will contain an additional four transmitters and 32 receivers, while the eight cells located at the apexes of the cube will each contain an additional eight receivers and one transmitter.

Other patterns such as a hypercube or a three- (or higher-) dimensional toroidal mesh can similarly be created using the cells as described herein in order to capitalize on the tremendous interconnectivity available today within a single semiconductor substrate. Note that the expression "dimension" here does not necessarily refer to the spatial extent of the cells' physical layout, rather it describes the functional relationship between groups of cells. Thus it is possible to realize an array of cells where the cells are arranged functionally in three or more dimensions while physically the cells occupy more or less the same plane or occupy a three-dimensional stack of planes or other region of a semiconductor substrate. Thus, it is within the scope of the invention to take advantage of advances in lithography which would increase the allowable circuit density on a chip so as to allow the switch fabric to be implemented logically as four-dimensional yet on a physically two- or three-dimensional substrate.

Moreover, it is envisaged that although it may be desired to interconnect N cells according to a particular interconnect pattern, a larger number of cells could be initially designed onto the semiconductor substrate, with an interconnect pattern of which the desired interconnect pattern is a subset. Upon lithography and fabrication, faulty cells would be detected and these (along with, possibly, some fault-free cells if they are in excess of N) could be electronically or otherwise disabled so as to leave N fully operational cells with the desired interconnect pattern on the chip.

An example arrangement of the functional modules that make up an example cell (say, cell 114₁) is shown in greater detail in Fig. 2 for the case where each cell transmits packets to, and receives packets from, itself and every other cell. Cell 114₁ is seen to comprise a transmitter 140, N receivers 150₁...150_N, an input interface 116, an output interface 118 and an arbiter 260. Other embodiments of the invention, to be described in greater detail later on, may include a central processing unit (CPU, not shown in Fig. 2) in each cell for generating and processing specialized control information.

It may be advantageous to use electrical communication for currently available CMOS semiconductors or guided or free-space optics for compound semiconductors such as gallium arsenide or indium phosphide. In other embodiments, the input interface 116 and output interface 118 may communicate with the off-chip environment using a variety of media and techniques, including but not limited to sonic, radio frequency and mechanical communication.

The input interface 116 receives packets from an off-chip packet-forwarding module 226 via a data path 252 and forwards them to the transmitter 140 via a data path 230. Occupancy information regarding the transmitter 140 is provided to the input interface 116 via a set of *free_slot* lines 207; the input interface 116 provides this information to the off-chip packet-forwarding module 226 along a control path 254.

The receivers 150 are connected to the arbiter 260, which is connected to the output interface 118 via a data path 202. The output interface 118 supplies packets to an off-chip input queue 228 via a data path 256. Occupancy information regarding the off-chip input queue 228 is provided to the receivers 150 in the form of an *almost_full* flag 208 that runs through the output interface 118 in the opposite direction of traffic flow. This functionality may also be provided by an external back channel.

The interconnect pattern 112 includes "forward" channels 210_j , $1 \leq j \leq N$, and "reverse" (or "back") channels $212_{j,k}$, $1 \leq j \leq N$, $1 \leq k \leq N$. Forward channel 210_j is employed by the transmitter 140 in cell 114_j to send packets to a corresponding receiver 150_j located on each of the cells 114_k , $1 \leq k \leq N$. Back channel $212_{j,k}$ is used by the transmitter 140 in cell 114_k to access control information from receiver 150_k in cell 114_j . Thus, in this embodiment, in total, there are N forward channels, one for each cell, and there are N^2 back channels, one for each combination cell pairs.

10 The switch fabric 100 processes data organized into packets. Each such packet has one or more words, where the size of a word is generally fixed. In one embodiment, the forward channels 210 are selected to be one bit wide so as to allow data to be transferred serially. In another embodiment, the forward channels 210 are selected to be at least as wide as to allow a parallel data transfer involving two or more bits in an individual word. In yet another embodiment, the forward channels 210 are selected to be sufficiently wide so as to allow a parallel data transfer involving all the bits in an individual word.

On the other hand, the back channels 212 convey control information of relatively low bandwidth compared to the required capacity of the forward channels 210, and therefore an individual back channel may be designed as a serial link or one with a low degree of parallelism compared to that of a forward channel. Note that because the N^2 back channels 212 carry much less information than the main data paths, they can be much narrower (i.e., one to a few bits wide) or slower than the forward channels 210; alternatively, data from multiple back channels can be multiplexed onto a single physical channel, etc. It will be noted that arrangements where the back channel is designed to convey information in a parallel fashion are within the scope of the present invention.

30 It should be understood that the term "packet" is intended to designate, in a general sense, a unit of information. The scope of this definition includes, without being limited to, fixed-length datagrams, variable-length datagrams, information streams and other information formats. The various characteristics of a packet,

such as its length, priority level, destination, etc. can be supplied within the packet itself or can be provided separately.

5 Fig. 3 shows in more detail the structure of a packet 350 suitable for use with the present invention. Specifically, a first word (or group of words) of the packet 350 makes up the so-called "header" 360 and the remaining words of the packet 350 make up the so-called "payload" 370. In a non-limiting example embodiment, the size of the header 360 is a single word and the size of the payload 370 ranges from 7 to 23 words. In different embodiments within the scope of the present
10 invention, the number of words in each packet may be fixed or it may vary from one packet to another.

The header 360 has various fields that contain control information. For example, the header 360 may include a destination field 362, a priority field 364 and a
15 source field 366. The destination field 362 specifies the cell from which it is desired that the packet eventually exit the switch fabric 100. This cell may be referred to as the "destination cell". The destination field 362 may encode the destination cell in any suitable way, for example using a binary code to represent the destination cell or using a binary mask with a logic "1" in the position of the
20 destination cell.

In some embodiments of the invention capable of providing multicast functionality, there may be more than one destination cell specified in the destination field 362 of a given packet 350. For the time being, however, it will be assumed that only
25 each packet is associated with only one destination cell, the consideration of a multicast scenario being left to a later part of this specification.

The priority field 364 encodes a priority level associated with the packet 350. The priority level associated with a packet 350 basically indicates to the switch fabric
30 100 the relative urgency with which the packet in question is to be forwarded to its destination cell. The set of possible priority levels may include a finely graduated range encoded by, say, 8 bits (representing values between 0 and 255,

inclusively). In other embodiments, the set of possible priority levels may consist simply of "high", "medium" and "low" priority levels.

5 The source field 366 is optional in the case where a single switch fabric is considered in isolation. However, when multiple switch fabrics 100 of the type shown in Fig. 1 are interconnected, it may be useful for a downstream switch fabric that processes a packet received from an upstream switch fabric to know which cell on the upstream switch fabric actually sent the packet. Such information may suitably be contained in the source field 366 of the header 360 of
10 the packet 350.

Of course, it is to be understood that still other header fields not shown in Fig. 3 may be used to store additional control information related to the packet 350. For instance, a packet destined for the CPU in the destination cell may be so identified
15 in the header, as will a packet that has been generated by the CPU in a given cell. This functionality will be described in further detail later on. In other example embodiments, the header 360 may also contain a series of one or more "switch fabric chip" exit ports defining a predetermined path through a multi-stage fabric. Additionally, for each port on a line card, there may be one or more sub-ports.
20 The sub-port for which a particular packet is destined may be identified in a field of the packet's header 360.

While a packet may have a fixed or variable number of words, each word generally has a fixed number of bits (i.e., each word is of a fixed "width"). For
25 example, a word may include, say, 33 bits, among which 32 bits may carry actual information (which is of a different type for the header 360 and for the payload 370), and the 33rd bit may be an "end-of-packet" bit 368 that is set for a particular word when that word is a predetermined number of words from the end of the packet to which it belongs. Thus, detection of variations in the end-of-packet
30 (EOP) bit 368 of successive words allows an entity processing a stream of words to locate the beginning of a new packet. Specifically, when such an entity detects a falling edge in the EOP bit, it will expect the next packet to begin following

receipt of a predetermined number of additional words belonging to the current packet.

5 Alternative ways of indicating the length and/or the start of a packet will be known to those of ordinary skill in the art, such as, for example, including an additional field in the header 360 which specifies the length of the packet, in terms of the number of words. Of course, such measures are unnecessary when each packet is of a known and fixed length, since a word counter could be used as a reference in order to establish the expiry of one packet and the beginning of the next. As
10 will be understood by those of ordinary skill in the art, additional bits may be used for parity checking and other functions, for example.

A packet travelling through the switch fabric 100 of Fig. 2 undergoes three main stages of transmission. The first stage involves the packet being transmitted from
15 the off-chip environment to a given cell, say cell 114_J, via that cell's input interface 116; upon receipt, the transmitter 140 begins the process of writing the packet into a memory location in that cell. The second stage involves the packet being sent from the transmitter 140 in cell 114_J along the corresponding forward channel 210_J to receiver 150_J residing in the destination cell; upon receipt, the packet is
20 written into a memory location by receiver 150_J in the destination cell. Finally, the third stage involves the packet being sent from receiver 150_J in the destination cell via the arbiter 260 and through output interface 118 of that cell. In the illustrated embodiment, the output interface 118 is connected to the off-chip input queue 228 which provides additional buffering and feedback on the state of this
25 buffering, thus allowing an over-provisioned switch fabric to deliver bursts that temporarily exceed the capacity of the next link.

In accordance with an embodiment of the present invention, a packet having a given priority level is transmitted at a particular stage only if there is sufficient
30 room downstream to accommodate the packet, taking into consideration its priority level. This functionality is achieved by providing a packet transmission control mechanism at each stage of transmission in order to regulate packet flow

and achieve the most desired overall functionality. However, it is within the scope of the invention to omit one or more of the control mechanisms.

5 With regard to the first stage, the off-chip packet-forwarding module 226 controls the flow of packets to cell 114_J from the off-chip environment by consulting occupancy information provided by the transmitter 140 via control path 254. An example off-chip packet-forwarding module 226 will be described in greater detail later on; for now, it is sufficient to mention that it is advantageous to use the occupancy information in order to ensure that transmission of a packet to cell
10 114_J only occurs if the transmitter 140 can accommodate that packet.

With regard to the second stage, if lossless transmission is to be supported, it is advantageous for the control mechanism to ensure that the transmitter 140 in cell 114_J does not send the packet to receiver 150_J in the destination cell unless the
15 receiver in question can accommodate that packet. (The destination cell may be cell 114_J itself but is more generally denoted 114_j, $1 \leq j \leq N$). An example embodiment of such a control system is described herein below; for now, it is sufficient to mention that the transmitter 140 in cell 114_J uses back channel 212_{j,J} to monitor the status (occupancy) of individual memory locations in receiver 150_J
20 in cell 114_j, thereby to determine whether a packet can be accommodated by that receiver.

With regard to the third stage, in this embodiment, receiver 150_J in the destination cell relies on the *almost_full* flag 208 that provides occupancy information
25 regarding the off-chip input queue 228. This control mechanism is described herein below in greater detail; for now, it is sufficient to mention that receiver 150_J in the destination cell is prevented from requesting transmission of a packet unless it can be accommodated by the off-chip input queue 228.

30 Those skilled in the art will more fully understand the various stages of packet transmission and their associated control mechanisms in the context of the following detailed description of the individual functional modules of a generic cell of Fig. 2 with additional reference to Figs. 4, 5 and 7.

An example non-limiting implementation of the transmitter 140 in cell 114_j is now described with reference to Fig. 7. The transmitter 140 has a memory which includes various storage areas, including a data memory 702, a plurality of control memories 712, any memory used by a plurality of queue controllers 710 and any other memory used by the transmitter 140.

The transmitter 140 receives words from the input interface 116 along the data path 230. The words are fed to the data memory 702 via a set of data input ports. The data memory 702 is writable in response to receipt of a write address and a write enable signal from a packet insertion module 704 via a *write_address* line 716 and a *write_enable* line 718, respectively. The *write_address* line 716 carries the address in the data memory 702 to which the word presently on the data path 230 is to be written, while asserting a signal on the *write_enable* line 718 triggers the actual operation of writing this word into the specified address. In order to coordinate the arrival of packets at the data memory 702 with the generation of signals on the *write_address* line 716 and the *write_enable* line 718, the data path 230 may pass through an optional delay element 706 before entering the data input ports of the data memory 702.

In this example, the data memory 702 comprises N segments 713, one for each of the N cells on the chip 110. The j^{th} segment 713_j has the capacity to store a total of M packets destined for cell 114_j. More specifically, the j^{th} segment 713_j includes M slots 708_{j,A}, 708_{j,B}, ..., 708_{j,M}, each slot being of such size as to accommodate a packet. It should be understood that the invention is applicable to any suitable combination of N and M, depending on the operational requirements of the invention. In other embodiments, the data memory 702 may include a pool of memory that is capable of storing portions of incoming data streams.

Associated with each segment 713_j of the data memory 702 is a dedicated one of the queue controllers 710, specifically queue controller 710_j. Queue controller 710_j has access to an associated control memory 712_j. The control memory 712_j holds data representative of a degree of occupancy of the corresponding segment

713_j of the data memory 702. The term "degree of occupancy" should be understood to include information indicative of the amount of space in the data memory 702 and includes any data that can directly or indirectly provide such information. In some embodiments, this information may be expressed as a degree of vacancy or occupancy. In other embodiments, control memory 712 includes a plurality of entries 714_{j,A}, 714_{j,B}, ..., 714_{j,M} which store the occupancy status (i.e., occupied or unoccupied) of the respective slots 708_{j,A}, 708_{j,B}, ..., 708_{j,M} in the jth segment 713_j of the data memory 702. In addition, for each slot that is occupied, the corresponding entry stores the priority level of the packet occupying that slot. In one embodiment, the control memory 712_j and/or the entries 714_{j,A}, 714_{j,B}, ..., 714_{j,M} may take the form of registers, for example.

Different slots can be associated with different priority levels or, if there is a large number of possible priority levels, different slots can be associated with different priority "classes", such as "low", "medium" and "high". For example, given 256 possible priority levels (0 to 255), the low and medium priority classes could be separated by a "low-medium" priority threshold corresponding to a priority level of fabric 100, while the medium and high priority classes could be separated by a "medium-high" priority threshold corresponding to a priority level of 200.

In one embodiment of the invention, each segment includes at least one slot per priority class. By way of example, the jth segment 713_j of the data memory 702 may contain five slots 708_{j,A}, 708_{j,B}, 708_{j,C}, 708_{j,D}, 708_{j,E}, where slots 708_{j,A} and 708_{j,B} are associated with a high priority class, slots 708_{j,C} and 708_{j,D} are associated with a medium priority class and slot 708_{j,E} is associated with a low priority class. It is to be understood, of course, that the present invention includes other numbers of slots per segment and other associations of slots and priority classes. For example, an embodiment could allow high-priority packets into any slot while reserving some slots exclusively for high-priority packets.

The packet insertion module 704 is operable to monitor the EOP bit 368 on each word received via the data path 230 in order to locate the header of newly received packets. It is recalled that the EOP bit 368 undergoes a transition (e.g.,

falling edge) for the word that occurs in a specific position within the packet to which it belongs. In this way, detection and monitoring of the EOP bit 368 provides the packet insertion module 704 with an indication as to when a new packet will be received and, since the header 360 is located at the beginning of the packet, the packet insertion module 704 will know when the header 360 of a new packet has arrived.

The packet insertion module 704 is further operable to extract control information from the header 360 of each newly received packet. Such information includes the destination of a newly received packet and its priority level for the purposes of determining into which slot it should be placed in the data memory 702. The packet insertion module 704 first determines into which segment a newly received packet is to be loaded. This is achieved by determining the cell for which the packet is destined by extracting the destination field from the header of the newly received packet. The destination field identifies one of the N cells 114 as the destination cell. The destination cell may be cell 114_J itself but is more generally denoted 114_j. Having determined the set of slots associated with the destination cell 114_j, the packet insertion module 704 determines the slot into which the received packet should be inserted. This is achieved by determining the priority class of the received packet and verifying the availability of the slot(s) associated with that priority class.

To this end, the packet insertion module 704 determines the priority class of a packet by comparing the priority level of the packet to the previously defined priority thresholds. For example, let slots 708_{j,A}, 708_{j,B}, 708_{j,C}, 708_{j,D}, 708_{j,E} be associated with high, high, medium, medium and low priority levels, respectively. Also, let the low-medium priority threshold and the medium-high priority threshold be as defined previously, namely, at 100 and 200, respectively. If the priority level of the received packet is 167, for example, then the appropriate slots into which the packet could be written include slots 708_{j,C} and 708_{j,D}.

Next, the packet insertion module 704 determines which of the appropriate slots is available by communicating with queue controller 710_j, to which it is connected via

a respective *queue_full* line 726_j and a respective *new_packet* line 728_j. Alternatively, a bus structure could be used to connect the packet insertion module 704 and the queue controllers 710. In either case, the packet insertion module 704 obtains the status (i.e., occupied or unoccupied) of the slots associated with the priority class of the received packet via the *queue_full* line 726_j.

The status information may take the form of a bit pattern which includes a set of positioned bits equal in number to the number of slots, where a logic value of 0 in a particular position signifies that the corresponding slot is unoccupied and where a logic value of 1 in that position signifies that the corresponding slot is indeed occupied. In this way, it will be apparent to the packet insertion module 704 which of the slots associated with the priority class of the received packet are available.

In the above example, where the priority class of the received packet was "medium" and slots 708_{j,C} and 708_{j,D} were associated with the medium priority class, queue controller 710_j would supply the occupancy of slots 708_{j,C} and 708_{j,D} via the *queue_full* line 726_j. This information is obtained by consulting entries 714_{j,C} and 714_{j,D} in control memory 712_j. Of course, it is within the scope of the invention for queue controller 710_j to provide, each time, the occupancy of all the slots in memory segment 713_j.

If only one slot for the packet's priority class is available, then that slot is chosen as the one to which the received packet will be written. If there is more than one available slot for the packet's priority class, then the packet insertion module 704 is free to choose any of these slots as the one to which the received packet will be written. It is advantageous to provide a mechanism ensuring that slots are always available for the packet's priority class, as this prevents having to discard or reject packets. One possible form of implementation of this mechanism is the regulation circuitry on off-chip packet-forwarding module 226, which would only have transmitted to cell 114_J if it knew that there was room in the transmitter 140 for a packet having the priority class in question. This feature will be described in greater detail later in this specification.

Having determined the segment and the slot into which the received packet shall be written to, the packet insertion module 704 determines a corresponding base address in the data memory 702. This may be done either by computing an offset that corresponds to the relative position of the segment and the relative position of the slot or by consulting a lookup table that maps segment and slot combinations to addresses in the data memory 702.

The packet insertion module 704 is adapted to provide the base address to the data memory 702 via the *write_address* line 716 and is further adapted to assert the *write_enable* line 718. At approximately the same time, the packet insertion module 704 sends a signal to queue controller 710_j along the appropriate *new_packet* line 728_j, such signal being indicative of the identity of the slot that is being written to and the priority level of the packet which is to occupy that slot. Queue controller 710_j is adapted to process this signal by updating the status and priority information associated with the identified slot (which was previously unoccupied).

After the first word of the received packet is written to the above-determined base address of the data memory 702, the address on the *write_address* line 716 is then incremented at each clock cycle (or at each multiple of a clock cycle) as new words are received along the data path 230. This will cause the words of the packet to fill the chosen slot in the data memory 702. Meanwhile, the packet insertion module 704 monitors the EOP bit 368 in each received word. When a new packet is detected, the above process re-starts with extraction of control information from the header 360 of the newly received packet.

In addition to being writable, the data memory 702 is also readable in response to a read address supplied by an arbiter 760 along a *read_address* line 792. In one embodiment, this may be implemented as a dual-port random access memory (RAM). In another embodiment, multiple data memories 702 may share a read port while each having an independent write port. As will be described in greater detail later on, the arbiter 760 initiates reads from the data memory 702 as a

function of requests received from the plurality of queue controllers 710 via a corresponding plurality of *request* lines 703. A particular *request* line 703_j will be asserted if the corresponding queue controller 710_j is desirous of forwarding a packet to receiver 150_J in cell 114_j.

5

One possible implementation of a queue controller, say, queue controller 710_j, adapted to generate a request for transmission of a received packet will now be described. Specifically, queue controller 710_j is operable to generate a request for transmitting one of the possible multiplicity of packets occupying the slots 708_{j,A}, 708_{j,B}, ..., 708_{j,M} in the data memory 702. The identity of the slot chosen to be transmitted is provided along a corresponding one of a plurality of *slot_id* lines 705_j while the priority associated with the chosen slot is provided on a corresponding one of a plurality of *priority* lines 707_j.

10

15

Each queue controller 710_j implements a function which determines the identity of the occupied slot which holds the highest-priority packet that can be accommodated by the receiver in the destination cell. This function can be suitably implemented by a logic circuit, for example. By way of example, each of the queue controllers 710_j in the transmitter 140 in cell 114_J can be designed to verify the entries in the associated control memory 712_j in order to determine, amongst all occupied slots associated with segment 713_j in the data memory 702, the identity of the slot holding the highest-priority packet. Queue controller 710_j then assesses the ability of the receiver in the destination cell (i.e., receiver 150_J in cell 114_j) to accommodate the packet in the chosen slot by processing information received via the corresponding back channel 212_{j,J}.

20

25

30

In one embodiment of the present invention, receiver 150_J in cell 114_j will comprise a set of M* slots similar to the M slots in the jth segment 713_j of the data memory 702, although M* may be different from M. The information carried by back channel 212_{j,J} in such a case will be indicative of the status (occupied or unoccupied) of each of these M* slots. (Reference may be had to Fig. 5, where the receiver slots are denoted 508. This Figure will be described in greater detail later on when describing the receiver.) Thus, by consulting back channel 212_{j,J},

queue controller 710_j in cell 114_J has knowledge of whether or not its highest-priority packet can be accommodated by the associated receiver 150_J in cell 114_j.

5 If the highest-priority packet can indeed be accommodated, then queue controller 710_j places the identity of the associated slot on the corresponding *slot_id* line 705_j, places the priority level of the packet on the corresponding *priority* line 707_j and submits a request to the arbiter 760 by asserting the corresponding *request* line 703_j. However, if the highest-priority packet cannot indeed be accommodated, then queue controller 710_j determines, among all occupied slots
10 associated with the segment 713_j in the data memory 702, the identity of the slot holding the next-highest-priority packet. As before, this can be achieved by processing information received via the corresponding back channel 212_{j,J}.

15 If the next-highest-priority packet can indeed be accommodated, then queue controller 710_j places the identity of the associated slot on the corresponding *slot_id* line 705_j, places the priority level of the packet on the corresponding *priority* line 707_j and submits a request to the arbiter 760 by asserting the corresponding *request* line 703_j. However, if the next-highest-priority packet cannot indeed be accommodated, then queue controller 710_j determines, among
20 all occupied slots associated with the segment 713_j in the data memory 702, the identity of the slot holding the next-next-highest-priority packet, and so on. If none of the packets can be accommodated or, alternatively, if none of the slots are occupied, then no request is generated by queue controller 710_j and the corresponding *request* line 703_j remains unasserted.

25 Assuming that queue controller 710_j has submitted a request and has had its request granted, it will be made aware of this latter fact by the arbiter 760. This exchange of information can be achieved in many ways. For example, the arbiter 760 may identify the queue controller whose request has been granted by sending
30 a unique code on a *grant* line 711 and, when ready, the arbiter 760 may assert a *grant_enable* line 715 shared by the queue controllers 710. Queue controller 710_j may thus establish that its request has been granted by (i) detecting a unique

code in the signal received from the arbiter via the *grant* line 711; and (ii) detecting the asserted *grant_enable* line 715.

It should be understood that other ways of signaling and detecting a granted request are within the scope of the present invention. For example, it is feasible to provide a separate grant line to each queue controller; when a particular queue controller's request has been granted, the grant line connected to the particular queue controller would be the only one to be asserted.

Upon receipt of an indication that its request has been granted, queue controller 710_j accesses the entry in the control memory 712_j corresponding to the slot whose packet now faces an imminent exit from the data memory 702 under the control of the arbiter 760. Specifically, queue controller 710_j changes the status of that particular slot to "unoccupied", which will alter the result of the request computation logic, resulting in the generation of a new request that may specify a different slot. The changed status of a slot will also be reflected in the information subsequently provided upon request to the packet insertion module 704 via the corresponding *queue_full* line 726_j.

Also upon receipt of an indication that its request has been granted, queue controller 710_j asserts a corresponding *pointer_update* line 729_j which returns back to the arbiter 760. As will be described later on in connection with the arbiter 760, assertion of one of the *pointer_update* lines 729_j indicates to the arbiter 760 that the grant it has issued has been acknowledged, allowing the arbiter 760 to proceed with preparing the next grant, based on a possibly new request from queue controller 710_j and on pending requests from the other queue controllers 710.

The function of the arbiter 760 is to grant one of the requests received from the various queue controllers 710 and to consequently control read operations from the data memory 702. To this end, the arbiter 760 comprises a request-processing module 770, an address decoder 780 and a packet-forwarding module 790.

The request-processing module 770 receives the *request* lines 703, the *priority* lines 707 and the *pointer_update* lines 729 from the queue controllers 710. The request-processing module 770 functions to grant only one of the possibly many requests received from the queue controllers 710. The request-processing module 770 has an output which is the *grant* line 711. The *grant* line 711 is connected to each of the queue controllers 710, as well as to the address decoder 780. In one embodiment of the present invention, the *grant* line 711 utilizes a unique binary code to identify the queue controller whose request has been granted.

The address decoder 780 receives the *grant* line 711 from the request-processing module 770 and the *slot_id* lines 705 from the queue controllers 710. The address decoder 780 computes a base address in the data memory 702 that stores the first word of the packet for which transmission has been granted. The base address is provided to the packet-forwarding module 790 via a *base_address* line 782.

The packet-forwarding module 790 receives, via the *base_address* line 782, the location of the first word of the next packet that it is required to extract from the data memory 702. The packet-forwarding module 790 stores the initial address on the *base_address* line 782. Once it has finished reading the current packet from the data memory 702, the packet-forwarding module 790, asserts the *grant_enable* line 715 and proceeds to cause words to be read from the data memory 702, starting at the initial address.

One possible implementation of the request-processing module 770, the address decoder 780 and the packet-forwarding logic 790 is now described with additional reference to Fig. 4. The request processing section 770 comprises a request generator 420, which is connected to the queue controllers 710 via the *request* lines 703 and the *priority* lines 707. The request generator 420 is also connected to a programmable round-robin arbiter (PRRA) 422 via a plurality of *request* lines

424 and may further be connected to a pointer control entity 412 via a control line 413.

5 The request generator 420 is adapted to admit only those requests associated with the maximum priority level amongst all the priority levels specified on the *priority* lines 707. To this end, the request generator 420 may be implemented as a maximum comparator that outputs the maximum value of the (up to N) received priority levels; this maximum value is then compared to all of the received priority levels on the *priority* lines 707, which would result in an individual one of the *request* lines 424 being asserted when the corresponding one of the *request* lines 10 703 is associated with the maximum priority level; the other *request* lines 424 would remain unasserted. As these highest-priority requests are eventually granted, the queue controllers 710 will generate new requests on the *request* lines 703, causing the output of the request generator 420 to change over time.

15 The requests on the *request* lines 424 are processed by the PRRA 422. The PRRA 422 has an output that is the shared *grant* line 711 that is provided to the queue controllers 710, to the pointer control entity 412 and to an address decoder 780. Among the possibly one or more *request* lines 424 being asserted, only one 20 of these will be granted by the PRRA 422 as a function of a "pointer" and a "mask" produced by the pointer control entity 412. As already described, the *grant* line 711 identifies the queue controller whose request has been granted, suitably in the form of a binary code which can uniquely identify each of the queue controllers 710.

25 In one embodiment, a pointer and a mask are defined for each of one or more possible priority levels. The mask associated with a given priority level indicates which queue controllers associated with that priority level remain as yet ungranted, while the pointer associated with a given priority level indicates which 30 of the queue controllers 710 was the most recent one to have its request granted. Among the multiple sets of pointer and mask pairs, the pointer control entity 412 submits only one pointer and one mask to the PRRA 422 at any given time.

To compute the pointer and the mask, the pointer control entity 412 requires knowledge of the information on the *request* lines 703 and the *priority* lines 707. This knowledge may be obtained either directly or from the request generator 420 via the control line 413. In addition, the pointer control entity 412 requires . 5 knowledge of the information circulating on the *pointer_update* lines 729 received from the queue controllers 710. As may be appreciated from the following, the pointer and mask submitted to the PRRA 422 allow it to be "fair" in deciding which should be the next queue controller to see its request granted.

10 To simplify the description, but without limiting the scope of the invention, it can be assumed that a pointer and a mask are not defined for each possible priority level, but rather for each of a set of priority classes, namely high, medium and low. Also, there are assumed to be four queue controllers 710₁, 710₂, 710₃, 710₄ that submit requests to the request generator 420.

15 By way of example, let the requests from queue controllers 710₁, 710₂, 710₃, 710₄ be associated with medium, NONE, low and medium priority classes, respectively. That is to say, queue controller 710₂ has not submitted a request. Accordingly, the initial "high" mask would be 0000 (as no request has a high 20 priority class), the initial "medium" mask would be 1001 (as queue controllers 710₁ and 710₄ have submitted requests associated with a medium priority class) and the initial "low" mask would be 0010 (as queue controller 710₃, has submitted a request associated with a low priority class). The initial value of each pointer would be set to zero, as no request has yet been granted.

25 In this example, the maximum priority class is medium. Hence, the request generator 420 submits only queue controller 710₁'s request and queue controller 710₄'s request to the inputs of the PRRA 422. Furthermore, the pointer control entity 412 provides the medium pointer and the medium mask to the PRRA 422. 30 As a result, the first request to be granted would thus be the either one submitted by either queue controller 710₁ or the one submitted by queue controller 710₄. Since the medium pointer is zero, the PRRA 422 has the choice of which request to grant; this can be resolved by providing simple, passive logic to make the

selection. Without loss of generality, let the very first granted request be that submitted by queue controller 710₁. The signal on the *grant* line 711 could accordingly be set to encode the value "1", indicative of the subscript 1 in 710₁.

5 As already described, queue controller 710₁ is adapted to acknowledge the grant of its request by way of the *pointer_update* line 729₁. Receipt of any acknowledgement by the pointer control entity 412 causes it to update its "active" pointer (namely, the one being provided to the PRRA 422). In this case, the acknowledgement received from queue controller 710₁ causes the pointer control
10 entity 412 to update the medium pointer to 1000.

Note that because its request has been granted, queue controller 710₁ will update the occupancy information in the appropriate entry in control memory 712₁, which may result in the submission of a new request to the request generator 420.
15 Assume for the moment that queue controller 710₁'s request has the same priority class as before, namely, medium. This causes the medium mask to become 0001, indicating that queue controller 710₄'s request still has not been granted in this round.

20 Now, assume that queue controller 710₃ at this point submits a high-priority request. This causes only queue controller 710₃'s request to make it past the request generator 420. The PRRA 422 therefore has no choice but to grant queue controller 710₃'s request. The signal on the *grant* line 711 could accordingly be set to encode the value "3", indicative of the subscript 1 in 710₃.

25 Queue controller 710₃ subsequently acknowledges the grant of its request by asserting the corresponding *pointer_update* line 729₃. Receipt of this acknowledgement by the pointer control entity 412 causes it to update its active pointer, in this case the high pointer, which will become 0010. Note that since its
30 request has been granted, queue controller 710₃ may now submit a new request but assume for the purposes of this example that it does not. The situation reverts to the previous one where the requests having the maximum priority class are again those coming from queue controllers 710₁ and 710₄.

Thus, the request generator 420 submits only queue controller 710₁'s request and queue controller 710₄'s request to the inputs of the PRRA 422, while the pointer control entity 412 provides the medium pointer (1000) and the medium mask (0001) to the PRRA 422. This indicates to the PRRA 422 that queue controller 710₄ has yet to be granted in this round and that the most recent queue controller to be granted was queue controller 710₁. Hence, the PRRA 422 has no choice but to grant queue controller 710₄, even though queue controller 710₁ also submitted a request having the same priority class. Still, this outcome is fair because queue controller 710₁'s request was granted last time.

It should therefore be appreciated that use of a pointer and a mask results in a fair arbitration process. In the absence of the pointer and mask being provided to the PRRA 422, the PRRA's simple logic would continue to grant queue controller 710₁ each time the situation would revert to one in which queue controller 710₁ would be among the set of queue controllers having the maximum priority class. Thus, it should be apparent that the pointer control entity 412 allows the PRRA 422 to grant requests in a truly fair manner; in the above example, queue controller 710₁ was prevented from unjustly monopolizing the data path 202.

Those skilled in the art should appreciate that other techniques for arbitrating amongst a plurality of requests are within the scope of the present invention. For example, although the pointer control entity 412 is useful in transforming the PRRA 422 into a fair round robin arbitrator, it is not an essential requirement of the invention. In fact, even a simple priority comparator would achieve the task of admitting only one of the requests and blocking the rest.

It should further be appreciated that if no requests are submitted to the request generator 420, then no request would end up being granted by the PRRA 422. In this case, the output of the *grant* line 711 at the output of the PRRA could be set to encode a value that does not identify any of the queue controllers, for example "FFFFFFF" or "deadcode" in hexadecimal.

In addition to being provided to the queue controllers 710, the code specified in the signal on the *grant* line 711 is also provided to the address decoder 780. The address decoder 780 is adapted to compute a base address as a function of the code specified on the *grant* line 711 and on the contents of the particular *slot_id* line indexed by the code specified on the *grant* line 711. That is to say, the address decoder 780 uses the grant line to identify a segment in the data memory 702 and to index the *slot_id* lines 705 in order to identify a slot within the identified segment.

To this end, the address decoder 780 may comprise a multiplexer 784 and a combiner 786. The multiplexer 784 receives the *slot_id* lines 705 and is selectable by the *grant* line 711. The *grant* line 711 and the output of the multiplexer 784 feed into the combiner 786. If the code on the *grant* line 711 specifies an existing one of the queue controllers 710 (rather than the above-mentioned hexadecimal "FFFFFFFF" or "deadcode"), the combiner 786 is operable to output a base address which is equal to the sum of the segment size (i.e., $M \times$ the packet size) times the code specified on the grant line and the packet size times the output of the multiplexer 784. The base address is provided to the packet-forwarding module 790 along the *base_address* line 782.

It should be understood that if the code on the *grant* line 711 indicates that no request has been granted, then the signal provided on the *base_address* line 782 can also be set to encode a predetermined code that does not refer to any address in the data memory 702, for example "FFFFFFFF" or "deadcode" in hexadecimal.

The packet-forwarding module 790 receives the base address from the address decoder 780 along the *base_address* line 782. The base address indicates the starting address of the next packet to be read out of the data memory 702 by the packet-forwarding module 790. However, the packet-forwarding module 790 in the arbiter 760 in cell 114_J may be in the process of placing a current packet onto the forward channel 210_J and thus the packet-forwarding module 790 is operable

to wait until it has finished reading out the current packet before beginning to cause the next packet to be read from the data memory.

In order to determine the end of the current packet, the packet-forwarding module 790 monitors the EOP bit 368 of each word being forwarded along forward channel 210_j by the data memory 702. The EOP bit 368 from successive words forms a EOP bit stream which will undergo a transition (e.g., falling edge) at a predetermine number of words prior to the end of the packet. In this way, the packet-forwarding module 790 knows when it is near the end of a packet.

Upon detecting a falling edge in the EOP bit stream, the packet-forwarding module 790 records the base address provided on the *base_address* line 782 and triggers the next grant via the *grant_enable* line 715. The packet-forwarding module 790 then proceeds to cause the words of the next packet to be read from the data memory 702. This is achieved by providing a read address along a *read_address* line 792. The first address placed on the *read_address* line 792 is the base address and the address is incremented until the end of this next packet is detected, and so on.

Assertion of the *grant_enable* line 715 causes the following chain reaction. Specifically, assertion of the *grant_enable* line 715 will affect only the queue controller whose request has been granted. Assume, for the sake of this example, that this queue controller is queue controller 710_j, and that it had requested transmission of the packet in slot 708_{j,B}. Upon detection of the *grant_enable* line 715 being asserted, queue controller 710_j will send an acknowledgement via the corresponding *pointer_update* line 729_j, which will trigger an update in the active pointer stored by the pointer control entity 412 and used by the PRRA 422. In addition, queue controller 710_j will access entry 714_{j,B}, which is associated with slot 708_{j,B}. More specifically, it will modify the occupancy status of slot 708_{j,B} to indicate that this slot is no longer occupied.

Modification of the occupancy status of slot 708_{j,B} may cause one or more of the following:

- (i) Firstly, the change in occupancy status may cause the logic in the queue controller 710_j to update the signals on the corresponding *request* line 703_j, *slot_id* line 705_j and *priority* line 707_j;
- 5 (ii) Secondly, the change in occupancy status will be signaled to the packet insertion module 704 via the *queue_full* line 726_j, which may change the outcome of the decision regarding where a received packet may be inserted;
- 10 (iii) Thirdly, the change in occupancy status will be sent to the input interface 116 via the *free_slot* line 207_j; the input interface 116 subsequently alerts the off-chip packet-forwarding module 226 that there is room in slot 708_{j,B}, which may trigger the transmittal of a new packet to the transmitter 140 via the input interface 116.

15 Depending on the interconnect pattern, a packet transmitted from one cell 114_j arrives at the corresponding receiver 150_j in one or more cells (possibly including cell 114_j itself) by virtue of the corresponding shared forward channel 210_j. Of course, some of the cells receiving the packet will be destination cells for that packet while others will not. The structure and operation of a receiver, say,

20 receiver 150_j in cell 114_K, is now described with reference to Fig. 5.

The receiver 150_j has a memory which includes various storage areas, including a data memory 502, a control memory 512, any memory used by a queue controller 510 and any other memory used by the receiver 150_j. Words received via forward

25 channel 210_j and destined for receiver 150_j in cell 114_K are fed to the data memory 502 via a plurality of data input ports.

The data memory 502 is writable in response to a write address and a write enable signal received from a packet insertion module 504 via a *write_address*

30 line 516 and a *write_enable* line 518, respectively. The *write_address* line 516 carries the address in the data memory 502 to which the word presently on the forward channel 210_j is to be written, while the actual operation of writing this word into the specified address is triggered by asserting a signal on the

write_enable line 518. In order to coordinate the arrival of packets at the data memory 502 with the generation of signals on the *write_address* line 516 and the *write_enable* line 518, the forward channel 210_j may pass through an optional delay element 506 before entering the data input ports of the data memory 502.

5

The data memory 502 contains M^* slots 508_A, 508_B, ..., 508_{M*}, where each slot is large enough to accommodate a packet as described herein above. Thus, the data memory requirement for a receiver 150 is M^* packets. The data memory 502 may be referred to as a sector of memory and slots 508 may be referred to as subdivisions. Recalling that the transmitter 140 on a given cell needs to fit $N \times M$ packets, and given that there are N receivers per cell and N cells per chip 110, the total data memory requirement for the chip 110 is on the order of $N \times ((N \times M) + (N \times M^*))$ packets, which is equal to $N^2 \times (M + M^*)$ packets, not counting the memory requirement of the other components such as the queue controllers, PRRA, etc.

15

Clearly, the total memory requirement for the chip 110 is a quadratic function of the number of cells and a linear function of both M and M^* . Given a fixed number of cells, the memory requirement can be tamed only by varying M and M^* . It is therefore of importance to pay attention to the values of M and M^* when aiming for a design that requires all the cells to fit on a chip.

20

The relationship between M^* and M is also important. For instance, to make M^* greater than M would mean that more packets can be stored in the receiver than in the segment of the transmitter dedicated to that receiver. Although this option is within the scope of the present invention, it does not allow all M^* slots of the receiver to be kept busy, thereby missing out on an otherwise available degree of parallelism. A borderline case, also within the scope of the invention, arises where M^* is equal to M , although even a single-cycle latency will put a high degree of parallelism out of reach.

25

30

Thus, the preferred approach is to make M^* (the receiver data memory size) less than M (the transmitter per-segment data memory size). An even more preferred

approach makes M^* just slightly less than M in order to minimize overall memory. An even more highly preferred approach makes M^* just large enough to accommodate a small number of packets associated with each priority "rank" (e.g., high, medium low) to allow additional packets of a given priority to be received while status information is returned via the appropriate back channel, while making M equal to or slightly less than the double of M^* . For instance, suitable values of M and M^* include, but are not limited to 3 and 5, respectively or 4 and 7, respectively. In one specific embodiment of the invention, the data memory 502 includes three slots 508_A, 508_B, 508_C, where slot 508_A is associated with a high priority class, slot 508_B is associated with a medium priority class and slot 508_C is associated with a low priority class.

The receiver 150_j also comprises queue controller 510. Queue controller 510 has access to control memory 512 which is subdivided into a plurality of entries 514_A, 514_B, ..., 514_{M*} for storing the occupancy status (i.e., occupied or unoccupied) of the respective slots 508_A, 508_B, ..., 508_{M*} in the data memory 502. Additionally, for each slot that is occupied, the corresponding entry stores the priority level of the packet occupying that slot. In one embodiment, the entries 514_A, 514_B, ..., 514_{M*} may take the form of registers, for example. In other embodiments, the control memory 512 may store a degree of occupancy or vacancy of the data memory 502.

The packet insertion module 504 is operable to monitor the EOP bit 368 on each word received via the forward channel 210_j in order to locate the header of newly received packets. It is recalled that the EOP bit 368 undergoes a transition (e.g., falling edge) for the word that occurs in a specific position within the packet to which it belongs. In this way, detection and monitoring of the EOP bit 368 provides the packet insertion module 504 with an indication as to when a new packet will be received and, since the header 360 is located at the beginning of the packet, the packet insertion module 504 will know where to find the header 360 of a newly received packet.

The packet insertion module 504 extracts control information from the header 360 of each newly received packet. Such information includes the destination of a newly received packet and its priority level for the purposes of determining into which slot it should be placed in the data memory 502. The packet insertion module 504 accepts packets destined for cell 114 κ and ignores packets destined for other cells. The packet insertion module 504 also determines the slot into which an accepted and received packet should be inserted. This is achieved by determining the priority class of the received packet and verifying the availability of the slot(s) associated with that priority class.

10

To this end, the packet insertion module 504 in cell 114 κ is operable to verify whether the destination specified in the destination field 360 of the received packet corresponds to cell 114 κ . In the case where all packets are non-multicast packets, each packet specifies but a single destination cell and hence this portion of the packet insertion module 504 functionality may be achieved by a simple binary comparison. Packets found to be destined for cell 114 κ are accepted for further processing while others are ignored.

15

20

Assuming that a received packet is accepted, the packet insertion module 504 is operable to determine the priority class of the packet by comparing the priority level of the packet to the previously defined priority thresholds. By way of example, as suggested herein above, let slots 508 A , 508 B , 508 C be associated with high, medium, and low priority levels, respectively. Also, let the low-medium priority threshold and the medium-high priority threshold be established as previously defined, namely, at 100 and 200, respectively. If the priority level of the received packet is 83, for example, then the slot into which it should be written would be slot 508 C .

25

30

In this embodiment, the packet insertion module 504 knows that it can write the received packet into slot 508 C because, it will be recalled, the packet could only be transmitted on the forward channel 210 j if the corresponding slot were available in the first place. Nonetheless, it is within the scope of the present invention to include larger numbers of slots where more than one slot would be

associated with a given priority class, which may require the packet insertion module 504 to verify the occupancy of the individual slots 508 by consulting a *queue_full* line 526 received from the queue controller 510.

5 Next, the packet insertion module 504 determines a corresponding base address in the data memory 502 into which the first word of the packet is to be written. This may be done either by computing an offset which corresponds to the relative position of the chosen slot (in this case slot 508_C) or by consulting a short lookup table that maps slots to addresses in the data memory 502.

10

The packet insertion module 504 is operable to provide the base address to the data memory 502 via the *write_address* line 516 and is further operable to assert the *write_enable* line 518. At approximately the same time, the packet insertion module 504 sends a signal to the queue controller 510 along a *new_packet* line 15 528, such signal being indicative of the identity of the slot which is being written to and the priority level of the packet which shall occupy that slot. The queue controller 510 is adapted to process this signal by updating the status and priority information associated with the identified slot (which was previously unoccupied).

20

After the first word of the received packet is written to the above-determined base address of the data memory 502, the address on the *write_address* line 516 is then incremented at each clock cycle (or at each multiple of a clock cycle) as new words are received along the forward channel 210_j. This will cause the words of the packet to fill the chosen slot in the data memory 502. Meanwhile, the EOP bit 25 368 in each received word is monitored by the packet insertion module 504. When a new packet is detected, the above process re-starts with extraction of control information from the header 360 of the newly received packet.

30

In addition to being writable, the data memory 502 is also readable in response to receipt of a read address supplied along a corresponding *read_address* line 593_j by an arbiter 260 common to all receivers 150 in the cell 114_K. As will be described in greater detail later on, the arbiter 260 initiates reads from the data memory 502 as a function of requests received from the queue controller 510 on

each of the receivers 150 via a corresponding plurality of *request* lines 503. A particular *request* line 503_j will be asserted if the queue controller 510 in the corresponding receiver 150_j is desirous of forwarding a packet to the off-chip input queue 228. Embodiments of the invention may include, without being limited to the use of, dual ported RAM or single ported RAM.

The following describes one possible implementation of the queue controller 510 in receiver 150_j which is adapted to generate a request for transmission of a received packet. Specifically, the queue controller 510 is operable to generate a request for transmitting one of the possible multiplicity of packets occupying the slots 508_A, 508_B, ..., 508_M* in the data memory 502. The identity of the slot chosen to be transmitted is provided along a corresponding *slot_id* line 505_j, while the priority associated with the chosen slot is provided on a corresponding *priority* line 507_j.

The queue controller 510 implements a function which verifies the entries in the control memory 512 in order to determine the identity of the occupied slot which holds the highest-priority packet that can be accommodated by the off-chip input queue 228. This function can be suitably implemented by a logic circuit, for example. By way of example, the queue controller 510 is designed to determine, amongst all occupied slots in the data memory 502, the identity of the slot holding the highest-priority packet. The queue controller 510 then assesses the ability of the off-chip input queue 228 to accommodate that packet by processing information received via the *almost_full* flag 208.

If the *almost_full* flag 208 is asserted, then it may be desirable to refrain from requesting the transmittal of further packets to the off-chip input queue 228. In some embodiments of the invention, the *almost_full* flag 208 may consist of a plurality of *almost_full* flags, one for each priority class (high, medium, low). This allows preferential treatment for high-priority packets by setting the occupancy threshold for asserting the high-priority *almost_full* flag higher than the threshold for asserting the low-priority *almost_full* flag.

If the highest-priority packet can indeed be accommodated, then the queue controller 510 places the identity of the associated slot on the corresponding *slot_id* line 505_j, places the priority level of the packet on the corresponding *priority* line 507_j and submits a request to the arbiter 260 by asserting the corresponding *request* line 503_j. However, if the highest-priority packet cannot indeed be accommodated, then the queue controller 510 determines, among all occupied slots in the data memory 502, the identity of the slot holding the next-highest-priority packet. As before, this can be achieved by processing information received via the *almost_full* flag 208.

10

If the next-highest-priority packet can indeed be accommodated, then queue controller 510 places the identity of the associated slot on the corresponding *slot_id* line 505_j, places the priority level of the packet on the corresponding *priority* line 507_j and submits a request to the arbiter 260 by asserting the corresponding *request* line 503_j. However, if the next-highest-priority packet cannot indeed be accommodated, then the queue controller 510 determines, among all occupied slots in the data memory 502, the identity of the slot holding the next-next-highest-priority packet, and so on. If none of the packets can be accommodated or, alternatively, if none of the slots are occupied, then no request is generated by the queue controller 510 and the corresponding *request* line 503_j remains unasserted.

15
20

Assuming that the queue controller 510 has submitted a request and has had its request granted, it will be made aware of this latter fact by the arbiter 260. This exchange of information can be achieved in many ways. For example, the arbiter 260 may identify the receiver containing the queue controller whose request has been granted by sending a unique code on a common *grant* line 511 and, when ready, the arbiter 260 may assert a *grant_enable* line 515 shared by the queue controller 510 in each of the receivers 150. The queue controller 510 may thus establish that its request has been granted by (i) detecting a unique code in the signal received from the arbiter 260 via the *grant* line 511; and (ii) detecting the asserted *grant_enable* line 515.

25
30

It should be understood that other ways of signaling and detecting a granted request are within the scope of the present invention. For example, it is feasible to provide a separate grant line to the queue controller in each of the receivers 150. In this case, when the request of a queue controller in a particular one of the receivers has been granted, the grant line connected to the particular receiver would be the only one to be asserted.

Upon receipt of an indication that its request has been granted, the queue controller 510 accesses the entry in the control memory 512 corresponding to the slot whose packet now faces an imminent exit from the data memory 502 under the control of the arbiter 260. Specifically, the queue controller 510 changes the status of that particular slot to "unoccupied", which will alter the result of the request computation logic, resulting in the generation of a new request which may specify a different slot. In the case where the packet insertion module 504 needs to know the status of a slot, the changed status of a slot will be reflected in the information provided via the *queue_full* line 526.

Also upon receipt of an indication that its request has been granted, the queue controller 510 asserts a corresponding *pointer_update* line 529_j which runs back to the arbiter 260. As will be described later on in connection with the arbiter 260, assertion of one of the *pointer_update* lines 529_j indicates to the arbiter 260 that the grant it has issued has been acknowledged, allowing the arbiter 260 to proceed with preparing the next grant, based on a possibly new request from the queue controller 510 in receiver 150_j and on pending requests from queue controllers in other ones of the receivers 150.

The function of the arbiter 260 is to receive a request from the queue controller 510 in each of the receivers 150, to grant only one of the requests and to control read operations from the data memory 502. To this end, the arbiter 260 comprises a request-processing module 570, an address decoder 580 and a packet-forwarding module 590. The arbiter 260 is very similar to the arbiter 760 previously described with reference to Fig. 4, with some differences in the

implementation of the address decoder 580 and the packet-forwarding module 590.

5 The request-processing module 570 receives, from the queue controller 510 in receiver 150_j, the corresponding *request* line 503_j, the corresponding *priority* lines 505_j and the corresponding *pointer_update* line 529_j. The request-processing module 570 functions to grant only one of the possibly many requests received in this fashion. The request-processing module 570 has an output which is the *grant* line 511. The *grant* line 511 is connected to each of the queue controller 510 in
10 each receiver, as well as to the address decoder 580. In one embodiment of the present invention, the *grant* line 511 utilizes a unique binary code to identify the queue controller whose request has been granted.

The address decoder 580 receives the *grant* line 511 from the request-processing
15 module 570 and the *slot_id* lines 505 from the queue controller 510 in each of the receivers 150. The address decoder 580 computes a base address in the data memory 502 that stores the first word of the packet for which transmission has been granted. The base address is computed as a function of the code specified on the *grant* line 511 and on the contents of the particular *slot_id* line indexed by
20 the code specified on the *grant* line 511. That is to say, the address decoder 580 uses the *grant* line to identify the receiver and to index the *slot_id* lines 505 in order to identify a slot within the data memory 502 of the identified receiver. The base address is provided to the packet-forwarding module 590 via a *base_address* line 582.

25 The packet-forwarding module 590 receives a base address via the *base_address* line 582. In addition, the packet-forwarding module 590 receives the *grant* line 511 from the request-processing module 570. The base address indicates the location of the first word of the next packet that is required to be extracted from
30 the data memory 502 of the receiver identified on the *grant* line 511.

Since the packet-forwarding module 590 may be in the process of reading a current packet from the data memory of another one of the receivers, the packet-

forwarding module 590 is programmed to wait until it has finished reading out the current packet before beginning to read the next packet. After it has finished reading the current packet from whichever data memory it is currently reading, the packet-forwarding module 590 stores the initial address on the *base_address* line 582, asserts the *grant_enable* line 515 and proceeds to read from the data memory 502 identified by the *grant* line 511, starting from the base address.

The output of the data memory 502 in the various receivers 150 arrives at a respective input port of a multiplexer 592. The multiplexer has an output which is placed onto the data path 202. Selection of which input port appears on the output port is controlled by a select line 595 received from the packet forwarding module 590. The select line 595 is a latched version of the *grant* line 511. Latching of the select line 595 occurs upon receipt of the *grant_enable* line 515.

In order to determine the end of the current packet, the packet-forwarding module 590 monitors the EOP bit 368 of each word traveling along the data path 202. The EOP bit 368 from successive words forms an EOP bit stream which will undergo a transition (e.g., falling edge) at a predetermine number of words prior to the end of the packet. In this way, the packet-forwarding module 590 knows when it is near the end of a packet. Upon detecting a falling edge in the EOP bit stream, the packet-forwarding module 590 records the base address provided on the *base_address* line 582 and triggers the next grant via the *grant_enable* line 515.

The packet-forwarding module 590 then proceeds to cause the words of a packet to be read from the data memory 502 of the receiver indexed by the *grant* line 511. This is achieved by providing a read address along the corresponding *read_address* line 593_j. The first address placed on the *read_address* line 593_j is the base address and the address is incremented until the end of the next packet is detected, and so on. It will be appreciated that rather than providing a separate *read_address* line for each receiver, there may be a single *read_address* line which passes through a demultiplexer (not shown) that is under control of the signal on the *grant* line 511.

Assertion of the *grant_enable* line 515 causes the following chain reaction. Specifically, assertion of the *grant_enable* line 515 will affect only the queue controller 510 on the receiver identified by the signal on the *grant* line 511. Assume, for the sake of this example, that the queue controller in question is the one in receiver 150_j, and that it had requested transmission of the packet in slot 508_C. Upon detection of the *grant_enable* line 515, the queue controller 510 will send an acknowledgement to the arbiter 260 via the corresponding *pointer_update* line 529_j, which will trigger an update in the active pointer stored by the pointer control entity and used by the PRRA in the request-processing module 570. In addition, the queue controller 510 will access entry 514_C, which is associated with slot 508_C. More specifically, it will modify the occupancy status of slot 508_C to indicate that this slot is no longer occupied.

Modification of the occupancy status of slot 508_C may cause one or more of the following:

- (i) Firstly, the change in occupancy status may cause the logic in the queue controller 510 to update the signals on the corresponding *request* line 503_j, *slot_id* line 505_j and *priority* line 507_j;
- (ii) Secondly, the change in occupancy status will be signaled to the packet insertion module 504 via the *queue_full* line 526_j, which may change the outcome of the decision regarding where a received packet may be inserted;
- (iii) Thirdly, the change in occupancy status is sent by the queue controller 510 along the back channel 212_{K,j} to the transmitter 140 in cell 114_j. This will alert the transmitter that there is room in slot 508_C, which may trigger the transmittal of a new packet to the receiver 150_j via forward channel 210_j.

Since a new packet will arrive after the old packet has begun to be read, this advantageously results in efficient data pipelining. Where the transmission of a packet is an atomic action that is at least as fast receipt of a new packet, the occupancy status of the slot corresponding to the old packet can be set to "no

longer occupied” as soon transmission begins. If receipt can be up to twice as fast as transmission, the occupancy status may be reset when one-half of the packet is transmitted, etc. Moreover, as already described, the features of the transmitter 140 will prevent transmission of a packet to occur unless the packet
5 can be accommodated by a receiver, thereby advantageously avoiding contention at the receiver which may arise if the transmission were effected without regard to the availability of space further downstream.

A packet entering the switch fabric 100 has a priority level which is identified in the
10 priority field 364 of the packet’s header 360. That same priority level is associated with the packet upon exit from the switch fabric 100. Nonetheless, it is within the scope of the present invention to provide a mechanism for temporarily modifying the priority level of the packet while the it is being processed by the transmitter or receiver in a given cell. More specifically, it is within the scope of the invention for
15 the transmitter or receiver on a given cell to maintain a “virtual” priority level associated with a packet and to use the virtual priority level in its decision-making process, without altering the actual priority level of the packet as defined in the packet’s header 360. It should therefore be appreciated that the priority level of a packet as stored in an entry of the control memory 512 of the queue controller 510
20 of the j^{th} receiver 150 $_j$ in the k^{th} cell 114 $_k$ or in an entry of the control memory 712 $_j$ of the j^{th} queue controller 710 $_j$ of the transmitter 140 in the k^{th} cell 114 $_k$ may refer either to the actual priority level of the packet or to its virtual priority level.

With additional reference to Fig. 6, there is shown a queue controller 610, which is
25 a modified version of queue controller 510 which was previously described with reference to the transmitter 140 in Fig. 5. The queue controller 610 has access to a “time stamp” from a time stamp counter 620 via a *time_stamp* line 605. The time stamp counter 620 is operable to track an ongoing measure of time, such as clock cycles. In other embodiments, time may be measured in terms of a number
30 of elapsed atomic events, a number of transmitted or received packets, etc. Accordingly, the time stamp counter 620 may be driven by the signal on a clock line 615 or on the aforescribed *grant_enable* line 515, among others.

The queue controller 610 has access to the control memory 512. It is recalled that the control memory 512 comprises a plurality of entries 514_A, 514_B, ..., 514_M^{*}. Each entry stores information pertaining to a corresponding slot 508 in the data memory 502. As has been previously described, the information in each entry is indicative of the availability of the corresponding slot and the priority level of the packet occupying that slot, if applicable. In order to implement an aging policy, additional information is stored in each of the entries 514.

Accordingly, entry 514_A includes a status field 632, a virtual priority field 634, a time stamp field 636 and an age mask field 638. The status field 632 is indicative of whether slot 508_A is occupied or unoccupied. The virtual priority field is indicative of the current virtual priority of the packet in slot 508_A. The time stamp field 636 is indicative of the time stamp which was in force at the time the packet currently occupying slot 508_A was written thereto. The age mask field 638 holds an increment which is added to the virtual priority at specific times as the packet ages. The increment may be fixed or variable, depending on the aging policy being implemented. If it is envisaged that the aging policy will always utilize a fixed aging mask (or if there is no aging policy), then the age mask field 638 is optional.

The queue controller 610 implements an aging policy (e.g., none, linear, exponential, logarithmic) by modifying the virtual priority of a packet as a function of a variety of parameters, including the age of the packet and one or more of the following: the contents of the age mask field 638, the kill limit value (the maximum age for a packet before the packet is eliminated from the data memory, regardless of its priority level), the time interval and the maximum allowable virtual priority level.

Fig. 8 illustrates the steps involved in administering an aging policy, in accordance with an embodiment of the present invention. At step 802, the queue controller 610 checks the *new_packet* line 528 in order to determine whether a new packet is about to be written into a slot in the data memory 502. If so, the *new_packet* line 528 will indicate the identity of the slot and its priority level. At step 804, the

queue controller 610 inserts the time stamp (received from the time stamp counter 620 via the *time_stamp* line 605) into the time stamp field 636 of the identified slot. In addition, the queue controller 610 selects a value to insert into the age mask field 638 of the identified slot. This value may be determined as a function of the priority level of the new packet, as received along the *new_packet* line 528. The queue controller 610 returns to step 802.

If, however, the queue controller 610 establishes at step 802 that no new packet is about to be written into the data memory 502, the queue controller 610 proceeds to step 806, where the queue controller 610 begins by selecting a first slot, say slot 508_A. The queue controller then executes step 808, which consists of obtaining the value in the time stamp field 636 of the corresponding entry (in this case 514_A) and subtracting it from the present time stamp as received from the time stamp counter 620. This produces an age value for the packet in the selected slot (in this case 508_A). At step 808, the queue controller 610 compares the age of the packet in the selected slot to a "kill limit", which represents the maximum allowable age of a packet.

If the kill limit is exceeded at step 810, the queue controller 610 proceeds to step 812, where the packet is effectively "eliminated" from the data memory 502. "Elimination" of a packet from the data memory 502 can encompass actual erasure of the packet from the corresponding slot in the data memory, as well as resetting of the status field 362 in the entry corresponding to the selected slot. After having eliminated the packet from the data memory 502, the queue controller 610 returns to step 802.

If the kill limit is not exceeded at step 810, the queue controller proceeds to step 814, where the contents of the age mask field 368 may or may not be added to the contents of the virtual priority field 364. If the contents of the age mask field 368 is indeed added to the contents of the virtual priority field 364, this results in a higher virtual priority level for the packet in the selected slot (in this case slot 508_A). Whether the contents of the age mask field 368 is added to the contents of the virtual priority field 364 depends on the aging policy in place. Also

dependent on the aging policy is the extent to which the age mask field 638 is updated at step 816.

5 According to a "no aging" policy, the virtual priority level of a packet does not change over time. According to a linear aging policy, a change is effected to the virtual priority level of a packet at fixed time intervals of duration T by a constant value V . The output of the time stamp counter 620 can be consulted in order to establish whether yet another time interval has elapsed, at which point it would be appropriate to update the virtual priority of the packet. The constant value V may
10 be specified in the age mask field 638 or it may be pre-determined.

According to the "exponential" aging policy, the virtual priority level is incremented by an exponentially increasing value $V(t)$ at fixed time intervals of duration T . Again, the output of the time stamp counter 620 can be consulted in order to
15 establish whether yet another time interval has elapsed, at which point it would be appropriate to update the virtual priority of the packet. In order to create the exponentially increasing value, a dynamic parameter is needed and this is provided by the age mask field 638. Specifically, adding the contents of an ever-increasing age mask field 638 to the contents of the virtual priority field 634 at
20 evenly spaced apart time intervals will result in an exponentially increasing value for the contents of both the age mask field 638 and the virtual priority field 634. In one example embodiment, the contents of the age mask field 638 is doubled every time the virtual priority level of the packet is updated.

25 According to the "logarithmic" aging policy, the virtual priority level is incremented by a constant value V at time intervals which increase in duration as a function of time. The constant value V may be pre-determined or it may be a function of the actual priority level of the packet. In order to create logarithmically increasing time intervals, a dynamic parameter is needed and this is provided by the age mask
30 field 638. Specifically, by comparing the contents of an ever-increasing age mask field 638 to the time stamp received from the time stamp counter 620 in order to decide whether to update the virtual priority level of the packet will result in such updates happening at a logarithmically decreasing rate. In one example

embodiment, the contents of the age mask field 638 is doubled every time the virtual priority level of the packet is updated. This effectively results in a slower aging process for the packet.

5 Other possible aging policies include but are not limited to policies quadratic and one-time increments or aging tables indexed off of a function of the packet age. Those skilled in the art will appreciate that a plurality of such aging policies can be implemented, with a different policy applied based on a packet property such as destination, priority, etc.

10

Finally, at step 818, the queue controller 610 determines whether it has considered all the slots 508 in the data memory 502 (i.e., whether it has considered all the entries 514 in the control memory 512). If so, the queue controller 610 returns to step 802; if not, the next slot is selected at step 820 and
15 the queue controller 610 proceeds to execute step 808 (and subsequent steps) using this next selected slot.

20

25

In some embodiments, the invention provides so-called "multicast" functionality, by virtue of which a packet entering the transmitter 140 in a given cell of the switch fabric 100 (say, cell 114_J) is sent via the corresponding forward channel 210_J to the corresponding receiver 150_J on multiple destination cells, possibly including cell 114_J itself. Such a packet is referred to as a multicast packet; a special case of a multicast packet is a broadcast packet, whose destination cells include all of the cells in the switch fabric 100. To accommodate the transmission
25 of multicast packets, the destination field 362 of the header 360 of a multicast packet is designed so as to be capable of specifying the two or more destination cells associated with the multicast packet. In one embodiment of the invention, this may be achieved by encoding the set of destination cells by way of a binary mask with a logic "1" in the position of each destination cell.

30

A multicast packet travelling through the switch fabric 100 of Fig. 2 undergoes three main stages of transmission, similar to the aforescribed stages of transmission which are experienced by a non-multicast packet. The first stage

involves the packet being transmitted from the off-chip environment to a given cell, say cell 114_J, via that cell's input interface 116; upon receipt, the packet is written into a memory location by the transmitter 140 in that cell. The second stage involves the packet being sent from the transmitter 140 in cell 114_J via the corresponding forward channel 210_J to the corresponding receiver 150_J residing in each of the two or more destination cells associated with the packet; upon receipt of the packet at each of the destination cells, the packet is written into a memory location by receiver 150_J in that destination cell. This operation is performed independently by the receiver in each destination cell. Finally, the third stage involves the packet being sent from receiver 150_J in each destination cell to the off-chip input queue 228 via the arbiter 260 and the output interface 118 of that destination cell.

To accommodate the transmission of multicast packets, the transmitter 140, previously described with reference to Fig. 7, needs to be modified. Fig. 9 shows an example non-limiting implementation of a transmitter 940 adapted to provide multicast functionality. Without loss of generality, the transmitter 940 is assumed to reside in cell 114_J. The transmitter 940 receives words from the input interface 116 along the data path 230. The transmitter 940 has a memory which includes various storage areas, including a data memory 902, a plurality of control memories 712, 912 a set of registers used by a plurality of queue controllers 710, 910 and any other memory used by the transmitter 940. The words are fed to the data memory 902 via a plurality of data input ports.

The data memory 902 is writable in response to a write address signal and a write enable signal, which continue to be received from a packet insertion module 904 via the *write_address* line 716 and the *write_enable* line 718, respectively. The *write_address* line 716 carries the address in the data memory 902 to which the word presently on the data path 230 is to be written, while the actual operation of writing this word into the specified address is triggered by asserting a signal on the *write_enable* line 718. In order to coordinate the arrival of packets at the data memory 902 with the generation of signals on the *write_address* line 716 and the

write_enable line 718, the data path 230 may pass through an optional delay element 706 before entering the data input ports of the data memory 902.

5 The data memory 902 comprises the previously described segments 713, one for each of the N cells on the chip 110. The j^{th} segment 713_j includes M slots 708_{j,A}, 708_{j,B}, ..., 708_{j,M}, each slot being of such size as to accommodate a packet destined for cell 114_j. Each of the segments 713 is represented by a
10 corresponding one of the queue controllers 710. Queue controller 710_j has access to an associated control memory 712_j comprising a plurality of entries 714_{j,A}, 714_{j,B}, ..., 714_{j,M} which store the occupancy status (i.e., occupied or unoccupied) of the respective slots 708_{j,A}, 708_{j,B}, ..., 708_{j,M} in the j^{th} segment 713_j of the data memory 902. For each slot that is occupied, the corresponding entry also stores the priority level of the packet occupying that slot.

15 In addition, the data memory 902 comprises an $N+1^{\text{th}}$ segment 913 for storing multicast packets. The different multicast packets stored in segment 913 may be destined for different combinations of two or more destination cells. Segment 913 includes M slots 908_A, 908_B, ..., 908_M, each slot being of such size as to accommodate a packet. In one embodiment of the invention, at least one slot is
20 reserved for each priority class. Segment 913 of the data memory 902 is represented by a multicast queue controller 910.

Multicast queue controller 910 has access to an associated control memory 912 comprising a plurality of entries 914_A, 914_B, ..., 914_M which store the occupancy
25 status (i.e., occupied or unoccupied) of the respective slots 908_A, 908_B, ..., 908_M in segment 913 of the data memory 902. Each entry also stores the priority level of the corresponding packet as well as an address mask identifying the set of destination cells for which the corresponding packet is destined. The occupancy status is provided to the input interface 116 via a *free_slot* line 901.

30 In a manner similar to that already described with reference to the packet insertion module 704, the packet insertion module 904 is operable to monitor the EOP bit 368 on each word received via the data path 230 in order to locate the header of

newly received packets. Because the EOP bit 368 undergoes a transition (e.g., falling edge) for the word that occurs in a specific position within the packet to which it belongs, detection and monitoring of the EOP bit 368 provides the packet insertion module 904 with an indication as to when a new packet will be received and, since the header 360 is located at the beginning of the packet, the packet insertion module 904 will know when the header 360 of a new packet has been received.

The packet insertion module 904 extracts control information from the header 360 of each received packet. Such information includes the destination cell (or cells) of a received packet and its priority level for the purposes of determining into which slot it should be placed in the data memory 902. The packet insertion module 904 first determines into which segment a received packet is to be written. This is achieved by extracting the destination 362 field from the header of the received packet in order to determine the destination cell (or cells) associated with the packet.

If the destination field 362 identifies one destination cell, then the received packet is a non-multicast packet and operation of the packet insertion module 904 in the case of a non-multicast cell is identical to that previously described with reference to the packet insertion module 704. However, if the destination field 362 identifies more than one destination cell, then the received packet is a multicast packet and the packet insertion module 904 operates differently. Specifically, the mere fact that a received packet is a multicast packet causes it to be written into segment 913. Selection of the particular slot into which the packet is written is achieved in a manner similar to that described with reference to the packet insertion module 704 of Fig. 7, namely by determining the priority class of the received packet and verifying the availability of the slot(s) associated with that priority class.

To this end, the packet insertion module 904 is operable to determine the priority class of a multicast packet by comparing the priority level of the packet to one or more priority thresholds. For example, let slots 908_A, 908_B, 908_C, 908_D, 908_E be associated with high, high, medium, medium and low priority levels,

respectively. Also, let the low-medium priority threshold and the medium-high priority threshold be as defined previously, namely, at 100 and 200, respectively. If the priority level of a received multicast packet is 229, for example, then the potential slots into which the packet could be written include slots 908_A and 908_B.

5

Next, the packet insertion module 904 is operable to determine which of the potential slots is available by communicating with the multicast queue controller 910, to which it is connected via a *queue_full* line 926 and a *new_packet* line 928. Alternatively, a bus structure could be used to connect the packet insertion module 904, the multicast queue controller 910 and the queue controllers 710. In either case, the packet insertion 904 module obtains the status (i.e., occupied or unoccupied) of the slots whose associated priority class matches the priority class of the received packet.

10

The status information may take the form of a bit pattern which includes a set of positioned bits equal in number to the number of slots, where a logic value of 0 in a particular position signifies that the corresponding slot is unoccupied and where a logic value of 1 in that position signifies that the corresponding slot is indeed occupied. In this way, it will be apparent to the packet insertion module 904 which of the slots associated with the priority class of the received packet are available.

15

20

In the above example, where the priority class of the received multicast packet was "high" and slots 908_A and 908_B were associated with the high priority class, the multicast queue controller 910 would supply the occupancy of slots 908_A and 908_B via the *queue_full* line 926. This information is obtained by consulting entries 914_A and 914_B in control memory 912. Of course, it is within the scope of the invention for the multicast queue controller 910 to provide, each time, the occupancy of all the slots in memory segment 913, not just those associated with the packet's priority class.

25

30

If only one slot associated with the packet's priority class is available, then that slot is chosen as the one to which the received packet will be written. If there is more than one available slot for the packet's priority class, then the packet

insertion module 904 is free to choose any of these slots as the one to which the received packet will be written. Note that it is advantageous to regulate transmission of packets to the transmitter 940 by the off-chip packet-forwarding module 226 in order to avoid the situation in which none of the slots would be available for the packet's priority class. This may be done by configuring the off-chip packet-forwarding module 226 so that it transmits the multicast packet to cell 114_J (*viz.* the illustrated cell) only if it knows that there is room in the transmitter 940 for a multicast packet having the priority class in question.

10 Having determined the slot into which the received multicast packet shall be written to, the packet insertion module 904 is operable to determine a corresponding base address in the data memory 902. This may be done either by computing an offset which corresponds to the relative position of the slot or by consulting a lookup table which maps slots to addresses in the data memory 902.

15 The packet insertion module 904 is adapted to provide the base address to the data memory 902 via the *write_address* line 716 and is further adapted to assert the *write_enable* line 718. At approximately the same time, the packet insertion module 904 sends a signal to the multicast queue controller 910 along the *new_packet* line 928, such signal being indicative of the identity of the slot which is being written to and the priority level of the packet which is to occupy that slot. The multicast queue controller 910 is adapted to process this signal by updating the status and priority information associated with the identified slot (which was previously unoccupied).

25 After the first word of the received multicast packet is written to the above-determined base address of the data memory 902, the address on the *write_address* line 716 is then incremented at each clock cycle (or at each multiple of a clock cycle) as new words are received along the data path 230. This will cause the words of the packet to fill the chosen slot in the data memory 902. Meanwhile, the EOP bit 368 in each received word is monitored by the packet insertion module 904. When a new packet is detected, the above process re-starts with extraction of control information from the header 360 of the newly received packet.

In addition to being writable, the data memory 902 is also readable in response to a read address supplied by an arbiter 960 along the *read_address* line 792. In a manner similar to that already described with reference to the arbiter 760 of Fig. 7, the arbiter 960 initiates reads from the data memory 902 as a function of requests received from the plurality of queue controllers 710, 910 via a corresponding plurality of *request* lines 703, 903. A particular *request* line 703_j will be asserted if the corresponding queue controller 710_j is desirous of forwarding a non-multicast packet to receiver 150_J in cell 114_j, while request line 903 will be asserted if the multicast queue controller 910 is desirous of forwarding a multicast packet to receiver 150_J in a multiplicity of cells 114_{j1}, 114_{j2}, ..., 114_{jp}.

The queue controllers 710 have already been described with reference to Fig. 7. The multicast queue controller 910, for its part, is implemented differently. The multicast queue controller 910 is adapted to generate a request for transmission of a received multicast packet to receiver 150_J residing in two or more destination cells 114_{j1}, 114_{j2}, ..., 114_{jp}. Specifically, the multicast queue controller 910 is operable to generate a request for transmitting one of the possible multiplicity of packets occupying the slots 908_A, 908_B, ..., 908_M in segment 913 of the data memory 902. The identity of the slot chosen to be transmitted is provided along a *slot_id* line 905 while the priority associated with the chosen slot is provided on a *priority* line 907.

The multicast queue controller 910 implements a function which determines the identity of the occupied slot which holds the highest-priority packet that can be accommodated by the destination receiver. This function can be suitably implemented by a logic circuit, for instance. By way of example, the multicast queue controller 910 can be designed to verify the entries in the associated control memory 912 in order to determine, amongst all occupied slots associated with segment 913 in the data memory 902, the identity of the slot holding the highest-priority packet. The multicast queue controller 910 then assesses the ability of receiver 150_J in each of the destination cells 114_{j1}, 114_{j2}, ..., 114_{jp} to

accommodate the packet in the chosen slot. This is achieved by processing information received via the corresponding back channels $212_{j1,J}$, $212_{j2,J}$, ..., $212_{jP,J}$.

5 For example, let the chosen multicast packet be a high-priority packet stored in slot 908_A and let the address mask of the packet be 1011, indicating that the multicast packet is destined for cells 114_1 , 114_3 and 114_4 . In this case, the required occupancy information would be relevant to slots 508_A (i.e., the high-priority slot) in receiver 150_J in cells 114_1 , 114_3 and 114_4 . This occupancy
10 information would be received via back channels $212_{1,J}$, $212_{2,J}$, and $212_{4,J}$.

If the multicast queue controller 910 finds that the chosen multicast packet can indeed be accommodated by the receiver in each destination cell, it will attempt to seize control of forward channel 210_J before any of the affected (non-multicast)
15 queue controllers 710 makes another request to the arbiter 960. Therefore, the multicast queue controller 910 makes a multicast request to the arbiter 960. In one embodiment, the multicast request is associated with a priority level associated with the packet. In other embodiments, the multicast request is given a higher priority in view of the probability associated with receiver 150_J being
20 available in all of the destination cells. The multicast queue controller 910 places the identity of the chosen slot on the *slot_id* line 905, places the priority level of the multicast request on the *priority* line 907 and submits a request to the arbiter 960 by asserting the *request* line 903.

25 Assuming that a request of this type submitted by the multicast queue controller 910 has been granted, the multicast queue controller 910 will be made aware of the grant by the arbiter 960. This exchange of information can be achieved in many ways. For example, in a manner similar to that previously described with reference to the arbiter 760, the arbiter 960 may identify the queue controller
30 whose request has been granted by sending a unique code on a *grant* line 911 and, when ready, the arbiter 960 may assert a *grant_enable* line 915 shared by the queue controllers 710, 910. A given queue controller would thus know that its request has been granted upon (i) detecting a unique code in the signal received

from the arbiter via the *grant* line 911; and (ii) detecting the asserted *grant_enable* line 915.

5 It should be understood that other ways of signaling and detecting a granted request are within the scope of the present invention. For example, it is feasible to provide a separate grant line to each queue controller, including the multicast queue controller 910 and the non-multicast queue controllers 710; when a particular queue controller's request has been granted, the grant line connected to the particular queue controller would be the only one to be asserted. In this case,
10 no grant enable line need be provided.

Upon receipt of an indication that its request has been granted, the multicast queue controller 910 accesses the entry in the control memory 912 corresponding to the slot whose packet now faces an imminent exit from the data memory 902
15 under the control of the arbiter 960. Specifically, the multicast queue controller 910 changes the status of that particular slot to "unoccupied", which will alter the result of the request computation logic, possibly resulting in the generation of a new request specifying a different slot. The changed status of a slot will also be reflected in the information provided to the packet insertion module 904 via the
20 *queue_full* line 926.

Also upon receipt of an indication that its request has been granted, the multicast queue controller 910 asserts a *pointer_update* line 929 which returns back to the arbiter 960. In a manner similar to that described in connection with assertion of
25 one of the *pointer_update* lines 729_j, assertion of the *pointer_update* line 929 indicates to the arbiter 960 that the grant it has issued has been acknowledged, allowing the arbiter 960 to proceed with preparing the next grant, based on a possibly new request from the multicast queue controller 910 and on pending requests from the other queue controllers 710.

30 However, in the case where the multicast queue controller 910 finds that one or more destination receivers cannot accommodate the multicast packet, the multicast queue controller 910 may do one of three things, depending on the

operational requirements of the invention. It can either (i) attempt to transmit the next-highest-priority multicast packet to all of the associated destination receivers; (ii) make a request to the arbiter 960 to transmit the multicast packet on the forward channel 210_J so that it is received by receiver 150_J on those destination
5 cells which have an available slot, while being ignored by receiver 150_J on other destination cells; (iii) wait some time before making another request to the arbiter 960.

10 It is also within the scope of the present invention to modify the virtual priority level of the multicast packet if one or more of the destination receivers cannot accommodate the packet. If the virtual priority level is increased to such an extent that the multicast packet now belongs to a different priority class, then a different result will be obtained when the multicast queue controller 910 determines the availability of a suitable slot within receiver 150_J in each destination cell.

15 In case (i) above, the multicast controller 910 makes an attempt to transmit the next-highest-priority multicast packet. This can be done by consulting the back channels 212 in order to assess the availability of receiver 150_J in each destination cell to accommodate the next-highest-priority multicast packet occupying one of the slots 908. If the multicast queue controller 910 again finds
20 that one or more destination cells cannot accommodate the multicast packet, the multicast queue controller 910 may attempt to transmit the next-next-highest-priority multicast packet, and so on.

25 In case (ii) above, the multicast controller 910 makes a request to the arbiter 960 to transmit the multicast packet on forward channel 210_J so that it is received by receiver 150_J in those destination cells which have an available slot. This may be achieved in the same way as if all the destination cells were able to accommodate the packet, i.e., by placing the identity of the chosen slot on the *slot_id* line 905,
30 placing the appropriate priority level on the *priority* line 907 and submitting a request to the arbiter 960 by asserting the *request* line 903. However, upon receipt of an indication that its request has been granted, the multicast queue

controller 910 would assert the *pointer_update* line 929 but would not yet change the status of the slot to “unoccupied”.

5 Next, the multicast queue controller 910 would reset the bits in the address mask of the corresponding entry in those bit positions corresponding to destination cells that were found to have an available slot for accommodating the multicast packet. For example, let the chosen multicast packet be a high-priority packet stored in slot 908_A and let the address mask of the packet be 1011, as before. Let the occupancy information relevant to slot 508_A in receiver 150_J in cells 114₁, 114₃
10 and 114₄, as received via respective back channels 212_{1,J}, 212_{2,J}, and 212_{4,J}, be the following: “occupied, unoccupied, unoccupied”. This would mean that there is room in slot 508_A in receiver 150_J in cells 114₃ and 114₄, but not in cell 114₁. If a request to transmit the multicast packet is granted, cells 114₃ and 114₄ will process the packet, but cell 114₁ will not. Consequently, the address mask would
15 become 1000 and may be referred to as “residual address mask”.

The residual address mask therefore indicates the destination cells of the multicast packet which have yet to receive the multicast packet. The multicast queue controller 910 is operable to make another request with the new address
20 mask in the above described manner until the address mask has been reduced to “0000”, at which point the multicast queue controller 910 would proceed with changing the status of the slot (in this case, slot 908_A) to “unoccupied” in the appropriate entry (in this case 914_A) in the control memory 912.

25 In addition, if a request to transmit the multicast packet to an incomplete subset of the destination cells has been granted, the multicast queue controller 910 must indicate to the packet-forwarding module in the arbiter 960 that the multicast packet has been transmitted to only some of the destination cells so that when the multicast packet is re-transmitted to the remaining destination cells by virtue of a
30 subsequent request being granted, it is not picked up a second time by the destination cells which already received the packet. To this end, upon being granted a request to send the multicast packet to an incomplete subset of the destination cells, an *already_sent* mask is provided via a control line 995 to the

packet-forwarding module 990 in the arbiter. The packet-forwarding module 990 uses the *already_sent* mask to modify the destination field 362 of the multicast packet in a manner to be described in greater detail herein below.

5 As a result, the destination field 362 of a multicast packet transmitted the first time to an incomplete set of destination cells will identify the original set of destination cells, while the destination field 362 of the same multicast packet, re-transmitted a second time due to some destination cells having had receivers that were not available the first time around, will identify only those destination cells which are
10 known to have an available slot for accommodating the packet. It is also within the scope of the invention, however, to modify the destination field 362 of a multicast packet transmitted the first time so that it specifies only those destination cells which are known to have an available slot for accommodating the packet.

15 In case (iii) above, upon finding that receiver 150_J in one or more destination cells cannot accommodate the multicast packet, the multicast queue controller 910 can be adapted to wait an amount of time (or a number of transmitted packets) before making a delayed request to the arbiter 960 along the *request* line 903. The delayed request follows a re-verification of the availability of receivers which were
20 initially found to be unavailable. Upon re-verification, it may be discovered that some additional receivers may have developed an availability to accommodate the packet.

The delayed request may be submitted in the same way as described with regard
25 to case (ii) above. However, it should be appreciated that during the time when the request is being delayed, one or more receivers that may have been available at the time when their availability was first verified (and the request withheld) may become unavailable. It is therefore possible that the situation with regard to receiver availability is no better after having delayed the request, unless some
30 way of making "tentative reservations" is provided. Accordingly, it is within the scope of the present invention for the multicast queue controller 910 to manipulate the request generation process in each of the non-multicast queue controllers 710

in such a way as to tentatively reserve a slot in receiver 150_J on those destination cells which can accommodate the multicast packet in question.

This can be achieved by altering the information received via the back channels 212, as perceived by the queue controllers 710. For example, the information regarding the availability of a given slot in receiver 150_J in cell 114_j, as received via back channel 212_{j,J}, might ordinarily be represented by logic "1" to indicate that the slot is available and by logic "0" to indicate that the slot is occupied. If that slot needs to be tentatively reserved by the multicast queue controller 910, then a two-input logical AND gate 999_j may be placed in the path of back channel 212_{j,J} prior to entry into any of the queue controllers 710. A first input of the AND gate would be the line 212_{j,J} leading from receiver 150_J in cell 114_j, while a second input of the AND gate may be supplied by the multicast queue controller 910 via a logical inverter (not shown). In operation, the multicast queue controller 910 would set the input to the inverter to logical "1" when making a tentative reservation for that slot, which would make the slot appear unavailable to the other queue controllers 710. The multicast queue controller 910 would reset the input to the inverter (thereby rendering the output of each AND gate 999_j transparent to information received via the corresponding back channel) after it has been granted a delayed request that followed the tentative reservation.

If, by the time the delayed requested is granted, it turns out that the multicast packet can be accommodated by receiver 150_J in all of the destination cells specified in its original destination field 362, then the multicast queue controller 910 proceeds as in case (i) above. If, however, receiver 150_J in some destination cells is still unable to accommodate the multicast packet, the multicast controller 910 proceeds as in case (ii) above.

The arbiter 960 is now described with continued reference to Fig. 9. The function of the arbiter 960 is to grant one of the requests received from the various queue controllers 710, 910 and to consequently control read operations from the data memory 902. To this end, the arbiter 960 comprises a request-processing module 970, an address decoder 980 and a packet-forwarding module 990. The arbiter

960 may be essentially identical to the arbiter 760 previously described with reference to Fig. 4, with some differences in the implementation of the request-processing module 970, the address decoder 980 and the packet-forwarding module 990.

5

The request-processing module 970 receives the *request* lines 703, 903, the *priority* lines 707, 907 and the *pointer_update* lines 729, 929 from the queue controllers 710, 910, respectively. The request-processing module 970 functions to grant only one of the possibly many requests received from the queue
10 controllers 710, 910 along the *request* lines 703, 903. The request-processing module 970 has an output which is the *grant* line 911. The *grant* line 911 is connected to each of the queue controllers 710, 910 as well as to the address decoder 980. In one embodiment of the present invention, the *grant* line 911 utilizes a unique binary code to identify the queue controller whose request has
15 been granted. It will be noted that the request-processing module 970 in the arbiter 960 differs from the request-processing module 770 in the arbiter 760 merely in the number of inputs.

The address decoder 980 receives the *grant* line 911 from the request-processing
20 module 970 and the *slot_id* lines 705, 905 from the queue controllers 710, 910, respectively. The address decoder 980 computes a base address in the data memory 902 that stores the first word of the packet for which a request for transmission has been granted. The base address is provided to the packet-forwarding module 990 via a *base_address* line 982. It will be noted that the
25 address decoder 980 in the arbiter 960 differs from the address decoder 780 in the arbiter 760 merely in its ability to process an additional code on the *grant* line 911 and in its ability to generate a base address over a wider range incorporating segment 913 in the data memory 902.

30 The packet-forwarding module 990 receives, via the *base_address* line 982, the location of the first word of the next packet that it is required to extract from the data memory 902. The packet-forwarding module 990 also receives the *already_sent* mask via the control line 995 from the multicast queue controller

910. It is recalled that the *already_sent* mask is indicative of one or more destination cells whose corresponding receiver 150_J has already received the packet to be extracted from the data memory 902 by the packet-forwarding module 990.

5

The packet-forwarding module 990 is operable to wait until it has finished reading out the current packet before beginning to read the next packet from the data memory. After it has finished reading the current packet from the data memory 902, the packet-forwarding module 990 stores the initial address on the *base_address* line 982, asserts the *grant_enable* line 915 and proceeds to read from the data memory 902 starting from the initial address. In addition, the packet-forwarding module 990 applies the *already_sent* mask to the destination field of the packet extracted from the data memory 902. The packet-forwarding module 990 in the arbiter 960 differs from the packet-forwarding module 790 in the arbiter 760 in its ability to index larger data memory 902 and in its ability to apply the *already_sent* mask to the destination field of a packet extracted from the data memory 902.

10

15

20

It is not necessary to modify the aforescribed receivers 150 or arbiter 260 in order to enable the processing of multicast packets arriving via the appropriate one of the forward channels 210.

25

30

It is noted that the packet insertion module 704 (or 904) in the transmitter 140 (or 940) controls where words are written into the data memory 702 (or 902), but it does not control the rate at which words arrive at the data input ports of the data memory 702 (or 902). This level of control is provided by an off-chip packet-forwarding module 226 as described herein below. The non-multicast case is considered for the purposes of the following but it should be appreciated that the concepts described herein below are equally applicable to the transmission of multicast packets.

Specifically, in preferred embodiments, the off-chip packet-forwarding module 226 is not allowed to send the words of a packet to the transmitter in a given cell

unless there is room in that transmitter's data memory 702 to accommodate the packet, as this prevents having to discard packets in the switch fabric chip. A feature of the present invention which allows such control to be executed locally at the off-chip packet-forwarding module 226 stems from the use of the entries 714 stored in the control memories 712. Specifically, by providing the status of slots 708 in the data memory 702 of the transmitter of each cell via the control path 254, the off-chip packet-forwarding module 226 can be alerted as to the status (occupied or unoccupied) of each slot associated with a particular category of priority level.

10

A detailed description of one possible implementation of the off-chip packet-forwarding module 226, along with its interaction with the input interface 116 and the output interface 118, is now provided with additional reference to Fig. 20. It is recalled that the off-chip packet-forwarding module 226 is connected to the input interface 116 in cell 114_J via data path 252 and a control path 254 (which flows in the opposite direction). The data path 252 can be of sufficient width to accommodate all the bits in a word or it may be narrower (and, therefore, also narrower than the data path 230) so as to accommodate only a subset of the bits in a word, thereby lowering the pin count of the chip 110. If the data path 252 is indeed narrower than the data path 230, then the input interface 116 should be configured to provide a rate matching functionality so that the total information transfer rate remains the same on both data paths. The control path 254 may be as narrow as one or two bits in order to keep the pin count to a minimum.

15

20

25

As can be seen in Fig. 20, the off-chip packet-forwarding module 226 comprises a buffer 2010, a controller 2020 and a memory 2030. A data path 2060 provides the buffer 2010 with a stream of packets for transmission to the transmitter 140 in cell 114_J. The controller 2020, which is connected to the buffer 2010 via a control line 2040, is adapted to control the release of words from the buffer 2010 onto the data path 252.

30

The memory 2030 stores a plurality ($N \times M$) of entries 2080. Entries 2080 may also be referred to as "zones". Entries 2080_{j,A} through 2080_{j,M} correspond to

slots $708_{j,A}$ through $708_{j,M}$, $1 \leq j \leq N$, in the data memory 702 of the transmitter 140. Each entry may include one or more bits which are indirectly indicative of whether the corresponding slot in the data memory 702 is occupied or unoccupied. By "indirectly", it is meant that the memory 2030 might not be accurate with regard to the occupancy status of a particular slot in the data memory 702 of the transmitter 140, but it will nevertheless contain an accurate version of the number of slots for a given destination and priority level which are occupied. The controller 2020 receives updated occupancy information from the transmitter 140 via the input interface 116 and the control path 254. The controller 2020 has access to the memory 2030 via a control line 2050.

In operation, the controller 2020 performs the tasks of updating the occupancy information in the memory 2030 and controlling the release of packets from the buffer 2010. The two tasks may be performed asynchronously.

Regarding the transmission of packets from the buffer 2010, this is performed as a function of the contents of the buffer 2010 and as a function of the occupancy information stored in the memory 2030. Specifically, when the buffer 2010 contains a packet that is ready for transmission to the transmitter 140, the controller 2020 verifies the destination cell associated with that packet and verifies its priority class, in a similar manner to the packet insertion module 704 in the transmitter 104.

Assume that the destination cell is cell 114_K . This means that it would be appropriate for the packet in question to occupy one of the slots $708_{K,A}$, ..., $708_{K,M}$ in the data memory 702. Furthermore, the priority level of the packet may further narrow the selection of appropriate slots into which the packet may be inserted once it arrives at the transmitter 140. Since the memory 2030 knows which slots are occupied and which ones are not, the controller 2020 can therefore determine whether the packet can be accommodated by an appropriate slot in the data memory 702.

In one embodiment, the controller 2020 does not allow the packet to be transmitted to the input interface 116 via the data path 252 unless at least one appropriate slot is found to be unoccupied. In this case, the controller 2020 would effectively reserve one of the appropriate slots by setting one of the appropriate (and unoccupied) entries in the memory 2030 to "occupied" prior to or during transmission of the packet to the transmitter 140. It is not important which slot is reserved in this manner, as long as the priority class and destination are consistent with the slot into which the packet will actually be inserted once it arrives at the data memory 702.

Regarding the "occupancy update" task, it is recalled that the *free_slot* lines 207 provide the input interface 116 with information as to the release of packets from the data memory. If, while monitoring the *free_slot* line 207, the input interface 116 determines the slot position of a packet being transmitted to its destination receiver, the input interface 116 will send a "token release" message to the controller 2020 via the control path 254. Such a token release message may specify the precise slot which has been vacated. However, because reservations in the memory 2030 are made as a function of destination and priority class, the input interface 116 need only send the segment (i.e., destination cell) and the priority class associated with the slot being liberated. Upon receipt of the "token release" message, the controller 2020 changes the information in one of entries in the memory 2030 which is associated with that destination and priority class and whose slot had been previously "reserved".

Accordingly, a slot will be reserved for a packet before the packet has a chance to arrive at the transmitter 140. This is advantageous when compared to the situation in which a slot is marked "occupied" once it is actually occupied, as it prevents the occurrence of a situation in which two packets are transmitted when there is room for only one.

In addition, once the packet arrives at the transmitter, it will be written into the data memory 702. As soon as it starts being written from memory, a "token release" message is sent back to the controller 2020 on control path 254. This indicates

to the controller 2020 that there is room in the transmitter 140 for a packet having a particular destination and priority class and an appropriate packet can be sent to the transmitter 140. This new packet will arrive after the old packet has begun to be read and, provided the write operation does not catch up to the read operation, advantageously resulting in efficient data pipelining, which is even more advantageously when combined with the efficient data pipelining that occurs between the transmitters 140 and receivers 150.

It is possible that due to a transmission error, the information contained in the "token release" message is incorrect. To this end, it may be advantageous to configure the controller 2020 so that it is capable of requesting the status of each slot in the data memory 702 of the transmitter 140, so as to perform a "refresh" of the memory 2030. This type of refresh operation may be performed at an initial phase or at other times during operation. This can be achieved by sending a "refresh request" message to the input interface 116 via a forward-traveling control path (not shown). The input interface 116 can be adapted to respond to a "refresh request" message by sending the occupancy status of each slot 708 in its data memory 702. This information is obtained from the entries 714 in the control memories 712. Upon receipt of the requested information from the input interface 116, the controller 2020 updates the contents of the entries 2080 in the memory 2030. In this way, the controller 2020 is able to gather information regarding the occupancy of each slot in the data memory 702.

It is also within the scope of the invention for the input interface 116 to have continuous access to up-to-date occupancy information by providing discrete or bussed signal connections between the input interface 116 and the entries 714 in the control memories 712 of the queue controllers 710. For example, such a bus may be $N \times M$ bits wide in some embodiments.

Reference is now made to Fig. 14, which shows a cell 1414₁ in accordance with another embodiment of the present invention, in which there is provided a central processing unit (CPU) 1400. Cell 1414₁ is a modified version of cell 114₁ described previously with reference to Fig. 2. Specifically, in addition to the CPU

1400, cell 1414₁ comprises an arrangement of functional modules including the previously described input and output interfaces 116, 118, as well as a modified transmitter 1440, N modified receivers 1450₁...1450_N, and two arbiters 260, 1460, among which arbiter 260 has already been described with reference to Fig.

5 5.

The main purpose of the CPU 1400 is to process, originate and/or respond to so-called "system packets". System packets generally do not carry data traffic; rather, they carry control information. Examples of control information which may
10 be carried by a system packet generated by the CPU 1400 include the number of packets sent by the transmitter 1440, the number of occupied slots in the data memory of the transmitter 1440, the number of occupied slots in the data memory of one or more receivers 1450, the total number of packets sent or received by the external ports 116, 118, the number of packets killed by the transmitter 1440 or
15 any receiver 1450, etc. Examples of control information which may be carried by a system packet destined for the CPU 1400 include instructions for changing the parameters used in the aging mechanism or setting the delay of a request by the multicast queue controller 910 in the transmitter (see Fig. 9) or instructing the time stamp counter 620 (see Fig. 6) to count packets sent rather than clock cycles (or
20 *vice versa*).

In one embodiment, the CPU 1400 can be a 32-bit 4-stage pipelined RISC processor with access to a CPU random access memory (RAM). The CPU RAM is divided into scratch RAM, insert RAM and forward RAM. The scratch RAM is
25 used for general computations of a temporary nature, while the insert RAM is used to store system packets arriving from the receivers 1450 and the forward RAM is used to store system packets to be transmitted along the appropriate forward channel by the transmitter 1440. In one embodiment, the size of both the insert RAM and the forward RAM can be one, two or more slots each, where each
30 slot is of sufficient size to store a packet. The total RAM size may be on the order of 2 kilobytes, for example. Of course, other CPU types and memory sizes are within the scope of the present invention.

The CPU 1400 in cell 1414₁ is also connected to other CPUs in other cells via an asynchronous peripheral bus 1472, which utilizes an internal peripheral bus interface 1470 in each cell, including cell 1414₁, and a common external peripheral bus interface (not shown) elsewhere on the chip 100. The internal peripheral bus interface 1470 in cell 1414₁ communicates the with external peripheral bus interface via the peripheral bus 1472. The purpose of the peripheral bus is to allow the CPU 1400 in each cell to exchange information with an external device (e.g., flash RAM, FPGA, UART, etc.) For example, the peripheral bus is useful when downloading the initial CPU code from an external memory device.

To accommodate the transmission of system packets to and from the CPU 1400, the destination field of the header of all packets is designed so as to be capable of specifying whether the packet is a system packet, i.e., is either destined for the CPU of a given destination cell or has been generated by the CPU of a given source cell. Accordingly, in one embodiment of the invention, and with reference to Fig. 18, a packet 1850 is provided with an additional "to CPU" (or TCPU) field 1810 and an additional "from CPU" (or FCPU) field 1820 in the packet's header 1860. To indicate that a packet is a system packet, either the TCPU field 1810 or the FCPU field 1820 is set (or both), as appropriate. If the packet 1850 is not a system packet, i.e., the packet 1850 is neither destined for the CPU of a given cell nor generated by the CPU of a given cell, then both the TCPU and FCPU fields 1810, 1820 remain blank.

If a packet is indeed a system packet, then further information concerning the meaning of the packet may be found in a subsequent word of the packet. For example, the second, third or other word of a system packet may contain a "type" field 1880. The type field 1880 identifies the nature of the control information carried by a system packet. When a system packet is routed to the CPU 1400, it will be processed according to the contents of the type field 1880. A system packet may also contain a password field 1890, which is encodable and decodable in software. Additionally, a system packet may include a query bit 1892, which indicates whether a response to the system packet is required from

the CPU 1400. Either or both of the password field 1890 and the query bit 1892, if used, may appear in the header 1860 of the packet 1850 or in a subsequent word in the payload of the packet 1850.

5 The flow of system packets and traffic packets (i.e., non-system packets) through cell 1414₁ may be better understood by additionally referring to Fig. 15, which is simplified version of Fig. 14 in which the solid line represents the path that may be traveled by traffic packets, while the dashed line represents the path that may be traveled by system packets. The arbiters 260, 1460 have been omitted for
10 simplicity of illustration.

With continued reference to Fig. 14, the input interface 116 receives system packets and traffic packets from the off-chip packet-forwarding module 226 via a data path 252 and forwards them to the transmitter 1440 via a data path 230
15 (previously described with reference to Fig. 2). Occupancy information regarding the transmitter 1440 is provided to the input interface 116 along a set of *free_slot* lines 207, which forwards this information to the off-chip packet-forwarding module 226 along an external back channel 254 (also previously described with reference to Fig. 2) running in the opposite direction of traffic flow.

20 The transmitter 1440 controls the transmission of system packets and traffic packets received from the off-chip packet-forwarding module 226 onto the corresponding forward channel, in this case forward channel 210₁. In addition, the transmitter 1440 also controls the transmission of system packets generated
25 by the CPU 1400, either independently or in response to a received system packet containing a query, onto forward channel 210₁. One way of achieving the desired functionality will be described in greater detail later on.

30 Within cell 1414₁, the receivers 1450 receive packets, word by word, along the forward channels 210. Each such received packet may be a traffic packet, a system packet destined for the CPU 1400 or a system packet not destined for the CPU 1400. System packets destined for the CPU 1400 are stored in a different

area than traffic packets or system packets that are not destined for the CPU 1400.

5 Requests for transmission of packets stored by the receivers 1450 may be made to arbiter 260 or to arbiter 1460. In the previously described manner, arbiter 260 is connected to the output interface 118 via the data path 202. The output interface 118 supplies packets to the off-chip input queue 228. Occupancy information regarding the off-chip input queue 228 is provided to the receivers 1450 in the form of the *almost_full* flag 208 (previously described) that runs through the output interface 118 in a direction opposite to that of traffic flow. This functionality may be provided by an external back channel. For its part, arbiter 1460 has an output connected to the CPU 1400 via a data path 1402. Occupancy information regarding the CPU 1400 is provided to the receivers 1450 in the form of a *cpu_almost_full* flag 1408.

15 It is noted that in this embodiment, system packets destined for the CPU 1400 in cell 1414₁, and which arrive via the off-chip packet-forwarding module 226, will reach the CPU 1400 via receiver 1450₁ in cell 1414₁ after having been placed onto forward channel 210₁ by the transmitter 1440 in cell 1414₁. It is envisaged that in other embodiments of the invention, such system packets may reach the CPU 1400 directly, without having to travel along forward channel 210₁.

25 With reference now to Fig. 16, there is shown an example non-limiting implementation of a transmitter 1440 adapted to allow the transmission of system packets and traffic packets along the appropriate forward channel. Without loss of generality, the transmitter 1440 is assumed to reside in cell 1414_J and hence the transmitter 1440 is connected to forward channel 210_J and back channels 212_{1,J}, 212_{2,J}, ..., 212_{N,J}.

30 The transmitter 1440 receives words from the input interface 116 along the data path 230. The words are fed to the data memory 702 via a plurality of data input ports. The data memory 702 is writable in response to a write address signal and a write enable signal, which are received from a packet insertion module 704 via

the *write_address* line 716 and the *write_enable* line 718, respectively. The *write_address* line 716 carries the address in the data memory 702 to which the word presently on the data path 230 is to be written, while the actual operation of writing this word into the specified address is triggered by asserting a signal on the *write_enable* line 718. In order to coordinate the arrival of packets at the data memory 702 with the generation of signals on the *write_address* line 716 and the *write_enable* line 718, the data path 230 may pass through an optional delay element 706 before entering the data input ports of the data memory 702.

10 The data memory 702 comprises the previously described segments 713, one for each of the N cells on the chip 110. Each of the segments 713 is represented by a corresponding one of a plurality of queue controllers 1610. Queue controller 1610_j has access to an associated control memory 712_j comprising a plurality of entries 714_{j,A}, 714_{j,B}, ..., 714_{j,M} which store the occupancy status (i.e., occupied or unoccupied) of the respective slots 708_{j,A}, 708_{j,B}, ..., 708_{j,M} in the jth segment 15 713_j of the data memory 702. For each slot that is occupied, the corresponding entry also stores the priority level of the packet occupying that slot.

In the manner already described with reference to Fig. 7, the packet insertion module 704 is operable to monitor the EOP bit 368 on each word received via the data path 230 in order to locate the header of newly received packets. Because the EOP bit 368 undergoes a transition (e.g., falling edge) for the word that occurs in a specific position within the packet to which it belongs, detection and monitoring of the EOP bit 368 provides the packet insertion module 704 with an indication as to when a new packet will be received and, since the header 360 is located at the beginning of the packet, the packet insertion module 704 will know when the header 360 of a new packet has been received.

The packet insertion module 704 extracts control information from the header 360 of each received packet. Such information includes the destination cell (or cells) of a received packet and its priority level for the purposes of determining into which slot it should be placed in the data memory 702. This information is obtained by extracting the destination field 362 from the header of the received

packet in order to determine the destination cell (or cells) associated with the packet. This automatically determines the segment into which the received packet is to be written. In addition, selection of the particular slot into which the packet belongs is achieved in the manner described with reference to the packet insertion module 704 of Fig. 7, namely, by determining the priority class of the received packet and verifying the availability of the slot(s) associated with that priority class. It is noted that the transmitter 1440 draws no distinction between system packets and traffic packets received from the input interface 116 along the data path 230.

The data memory 702 is also readable in response to a read address supplied by an arbiter 1660 along the *read_address* line 792. In a manner similar to that already described with reference to the arbiter 760 of Fig. 7, the arbiter 1660 initiates reads from the data memory 702 as a function of requests received from a plurality of queue controllers 1610, 1610^{CPU} via a corresponding plurality of *request* lines 1603, 1603^{CPU}.

A particular one of the *request* lines 1603_j will be asserted if the corresponding queue controller 1610_j is desirous of forwarding a traffic packet or a system packet to receiver 1450_J in cell 1414_j (possibly even cell 1414_J itself), while request line 1603^{CPU} will be asserted if the CPU queue controller 1610^{CPU} is desirous of forwarding a system packet from the CPU 1400 to receiver 1450_J in one of the cells (possibly even cell 1414_J itself).

The queue controllers 1610 generate requests in a manner similar to that of the queue controllers 710 described previously with respect to Fig. 7. Specifically, queue controller 1610_j is operable to generate a request for transmitting one of the possible multiplicity of packets occupying the slots 708_{j,A}, 708_{j,B}, ..., 708_{j,M} in the data memory 702. The identity of the slot chosen to be transmitted is provided along a corresponding one of a plurality of *slot_id* lines 1605_j while the priority associated with the chosen slot is provided on a corresponding one of a plurality of *priority* lines 1607_j.

Queue controller 1610_j implements a function which determines the identity of the occupied slot which holds the highest-priority packet that can be accommodated by the receiver in the destination cell. This function can be suitably implemented by a logic circuit, for example. By way of example, queue controllers 1610_j in the transmitter 1440 in cell 1414_J can be designed to verify the entries in the associated control memory 712_j in order to determine, amongst all occupied slots associated with segment 713_j in the data memory 702, the identity of the slot holding the highest-priority packet. Queue controller 1610_j then assesses the ability of the receiver in the destination cell (i.e., receiver 1450_J in cell 1414_j) to accommodate the packet in the chosen slot by processing information received via the corresponding back channel 212_{j,J}.

In one embodiment, receiver 1450_J in cell 1414_j includes a set of M** slots similar to the M slots in the jth segment 713_j of the data memory 702, but M** will be different from M. At least one of these slots will be reserved for accommodating packets destined for the CPU in that cell. The information carried by back channel 212_{j,J} in such a case will be indicative of the status (occupied or unoccupied) of each of these M** slots. (Reference may be had to Figs. 17A and 17B, where the receiver slots not reserved for the CPU are denoted 508 and where the receiver slots reserved for the CPU are denoted 1708. This Figure will be described in greater detail later on when describing the receiver.) Thus, by consulting back channel 212_{j,J}, queue controller 1610_j in cell 1414_J has knowledge of whether or not its highest-priority packet can be accommodated by the associated receiver 1450_J in cell 1414_j.

If the highest-priority packet can indeed be accommodated, then queue controller 1610_j places the identity of the associated slot on the corresponding *slot_id* line 1605_j, places the priority level of the packet on the corresponding *priority* line 1607_j and submits a request to the arbiter 1660 by asserting the corresponding *request* line 1603_j. However, if the highest-priority packet cannot indeed be accommodated, then queue controller 1610_j determines, among all occupied slots associated with the segment 713_j in the data memory 702, the identity of the slot

holding the next-highest-priority packet. As before, this can be achieved by processing information received via the corresponding back channel 212_{j,J}.

5 If the next-highest-priority packet can indeed be accommodated, then queue controller 1610_j places the identity of the associated slot on the corresponding *slot_id* line 1605_j, places the priority level of the packet on the corresponding *priority* line 1607_j and submits a request to the arbiter 1660 by asserting the corresponding *request* line 1603_j. However, if the next-highest-priority packet cannot indeed be accommodated, then queue controller 1610_j determines, among
10 all occupied slots associated with the segment 713_j in the data memory 702, the identity of the slot holding the next-next-highest-priority packet, and so on. If none of the packets can be accommodated or, alternatively, if none of the slots are occupied, then no request is generated by queue controller 1610_j and the corresponding *request* line 1603_j remains unasserted.

15

For its part, the CPU queue controller 1610^{CPU} is implemented quite differently from the queue controllers 1610. Specifically, the CPU queue controller 1610^{CPU} has access to an associated control memory 1612^{CPU}. The control memory 1612^{CPU} comprises one or more entries 1614^{CPU} which store the occupancy
20 status (i.e., occupied or unoccupied) of the respective slots in the forward RAM of the CPU 1400. For each slot in the forward RAM that is occupied (by a system packet), the corresponding entry in the control memory 1612^{CPU} also stores the priority level and the destination cell of that system packet.

25 The CPU queue controller 1610^{CPU} is operable to generate a request for transmitting a chosen one of the possible multiplicity of system packets occupying the forward RAM of the CPU 1400. Selection of the system packet to be transmitted is based upon the priority level of the packet and on the ability of receiver 1450_J in the destination cell to accommodate the chosen system packet.
30 This is achieved by processing information received via the appropriate one of the back channel 212_{j1,J}, 212_{j2,J}, ..., 212_{jP,J}.

This information will indicate whether the receiver in the destination cell has a free slot amongst its slots 508 (reserved for packets not destined for the CPU in that cell) or 708 (reserved for packets destined for the CPU in that cell). It is noted that both types of information are needed, as a system packet generated by the CPU 1400 and temporarily stored in the forward RAM may be destined for the CPU in the destination cell but it might just as easily *not* be destined for the CPU in the destination cell.

If the CPU queue controller 1610^{CPU} finds that the chosen system packet can indeed be accommodated by the receiver in the destination cell, it will make a request to the arbiter 1660. In one embodiment, such request is associated with a priority level identical to that of the system packet to be transmitted. In other embodiments, such request is given a lower priority in view of the fact that it is merely a system packet. In other, fault diagnosis situations, the request to transmit a system packet may be given a relatively high priority. To effect a request to the arbiter 1660, the CPU queue controller 1610^{CPU} places the priority level of the request on the *cpu_priority* line 1607^{CPU} and submits a request to the arbiter 1660 by asserting the *cpu_request* line 1603^{CPU}.

Assuming that a request is submitted by one of the queue controllers 1610, 1610^{CPU} has been granted by the arbiter 1660, queue controllers 1610, 1610^{CPU} will be made aware of this fact by the arbiter 1660. This exchange of information can be achieved in many ways. For example, in a manner similar to that previously described with reference to the arbiter 760, the arbiter 1660 may identify the queue controller whose request has been granted by sending a unique code on a *grant* line 1611 and, when ready, the arbiter 1660 may assert a *grant_enable* line 1615 shared by the queue controllers 1610, 1610^{CPU}. The targeted queue controller would thus know that its request has been granted upon (i) detecting a unique code in the signal received from the arbiter via the *grant* line 1611; and (ii) detecting the asserted *grant_enable* line 1615.

It should be understood that other ways of signaling and detecting a granted request are within the scope of the present invention. For example, it is feasible

to provide a separate grant line to each queue controller, including the CPU queue controller 1610^{CPU} and the other queue controllers 1610; when a particular queue controller's request has been granted, the grant line connected to the particular queue controller would be the only one to be asserted. In this case, no grant enable line need be provided.

Upon receipt of an indication that its request has been granted, queue controller 1610_j accesses the entry in the control memory 712_j corresponding to the slot whose packet now faces an imminent exit from the data memory 702 under the control of the arbiter 1660. Specifically, queue controller 1610_j changes the status of that particular slot to "unoccupied", which will alter the result of the request computation logic, resulting in the generation of a new request that may specify a different slot. The changed status of a slot will also be reflected in the information subsequently provided upon request to the packet insertion module 704 via the corresponding *queue_full* line 726_j.

On the other hand, upon receipt of an indication that *its* request has been granted, the CPU queue controller 1610^{CPU} accesses the entry 1614^{CPU} in the control memory 1612^{CPU} corresponding to the system packet to be transmitted. Specifically, the CPU queue controller 1610^{CPU} changes the status of that particular slot to "unoccupied", which will alter the result of the request computation logic, resulting in the generation of a new request that may specify a different slot.

Meanwhile, the CPU queue controller 1610^{CPU} places the system packet in the corresponding slot in the forward RAM of the CPU 1400 onto an output line 1621. Output line 1621 is multiplexed, at a multiplexer 1620, with the data exiting the data memory 702. The multiplexer 1620 is controlled by a signal on a select line 1689 which indicates whether or not the CPU queue controller 1610^{CPU} has been granted. This could be via a bit on the *grant* line 1611. That is to say, the state of the *grant* line 1611 may regulate whether the packet being sent along forward channel 210_j is taken from the data memory 702 or from the CPU queue controller 1610^{CPU}.

Also upon receipt of an indication that its request has been granted, the target queue controller 1610_j, 1610^{CPU} asserts a corresponding *pointer_update* line 1629_j, 1629^{CPU}, which returns back to the arbiter 1660. As will be described later on in connection with the arbiter 1660, assertion of one of the *pointer_update* lines 1629_j, 1629^{CPU} indicates to the arbiter 1660 that the grant it has issued has been acknowledged, allowing the arbiter 1660 to proceed with preparing the next grant, based on a possibly new request from the target queue controller and on pending requests from the other queue controllers.

The arbiter 1660 is now described with continued reference to Fig. 16. The function of the arbiter 1660 is to grant one of the requests received from the various queue controllers 1610, 1610^{CPU} and to consequently control read operations from the data memory 702 and from the forward RAM in the CPU 1400. To this end, the arbiter 1660 comprises a request-processing module 1670, an address decoder 1680 and the above-mentioned packet-forwarding module 1690. The arbiter 1660 may be similar to the arbiter 760 previously described with reference to Fig. 4, with some differences in the implementation of the request-processing module 1670, the address decoder 1680 and the packet-forwarding module 1690.

The request-processing module 1670 receives the *request* lines 1603, 1603^{CPU}, the *priority* lines 1605, 1605^{CPU} and the *pointer_update* lines 1629, 1629^{CPU} from the queue controllers 1610, 1610^{CPU}, respectively. The request-processing module 1670 functions to grant only one of the possibly many requests received from the queue controllers 1610, 1610^{CPU} along the *request* lines 1603, 1603^{CPU}. The request-processing module 1670 has an output which is the *grant* line 1611. The *grant* line 1611 is connected to each of the queue controllers 1610, 1610^{CPU} as well as to the address decoder 1680. In one embodiment of the present invention, the *grant* line 1611 utilizes a unique binary code to identify the queue controller whose request has been granted.

The address decoder 1680 receives the *grant* line 1611 from the request-processing module 1670 and the *slot_id* lines 1605 from the queue controllers 1610, respectively. If the *grant* line 1611 identifies a queue controller 1610 that is not the CPU queue controller 1610^{CPU}, then the address decoder 1680
5 computes, as a function of the slot specified on the appropriate *slot_id* line, a base address in the data memory 702 that stores the first word of the packet for which a request for transmission has been granted. The base address is provided to the packet-forwarding module 1690 via a *base_address* line 1682.

10 However, if the *grant* line 1611 identifies the CPU queue controller 1610^{CPU}, then a base address computation is not required, since the CPU queue controller 1610^{CPU} itself determines which system packet to transmit.

The packet-forwarding module 1690 is operable to wait until it has finished placing
15 the current packet onto the forward channel 210_J before placing the next packet onto the forward channel 210_J. After it has finished placing the current packet onto the forward channel 210_J, the packet-forwarding module 1690 consults the *grant* line 1611. If it indicates that the granted queue controller is *not* the CPU queue controller 1610^{CPU}, then the packet-forwarding module 1690 stores the
20 initial address on the *base_address* line 1682, asserts the *grant_enable* line 1615 and proceeds to read from the data memory 702 starting from the initial address. In addition, the packet-forwarding module 1690 controls the multiplexer 1620 via the select line 1689 so that it admits words coming from the data memory 702 and blocks words coming from the forward RAM of the CPU 1400.

25 If, on the other hand, the *grant* line 1611 indicates that the granted queue controller is the CPU queue controller 1610^{CPU}, then the packet-forwarding module 1690 asserts the *grant_enable* line 1615 and initiates a read operation from the forward RAM in the CPU 1400. In addition, the packet-forwarding
30 module 1690 controls the multiplexer 1620 via select line 1689 so that it admits words coming from the forward RAM of the CPU 1400 and blocks words coming from the data memory 702.

At a given receiver, all received packets along the corresponding forward channel which are either traffic packets or system packets not destined for the CPU are processed as previously described with reference to the receiver of Fig. 5. However, the way in which system packets whose destination cell corresponds to the cell in which the receiver is located and which are specifically destined for the CPU 1400 in the destination cell are processed differently and hence it is necessary to modify the receiver previously described with reference to Fig. 5.

To this end, Figs. 17A and 17B show a receiver 1450_j adapted to process system packets received via forward channel 210_j. The receiver 1450_j has a memory which includes various storage areas, including a data memory 1702, a control memory 1712, any memory used by a queue controller 1710 and any other memory used by the receiver 1450_j.

Received cells are fed to the data memory 1702 via a plurality of data input ports. The data memory 1702 is writable in response to a write address and a write enable signal received from a packet insertion module 1704 via the previously described *write_address* line 516 and a *write_enable* line 518, respectively. The *write_address* line 516 carries the address in the data memory 1702 to which the word presently on the forward channel 210_j is to be written, while the actual operation of writing this word into the specified address is triggered by asserting a signal on the *write_enable* line 518. In order to coordinate the arrival of packets at the data memory 1702 with the generation of signals on the *write_address* line 516 and the *write_enable* line 518, the forward channel 210_j may pass through the previously described optional delay element 506 before entering the data input ports of the data memory 1702.

The data memory 1702 contains M** slots 508, 1708, including the M* previously described slots 508_A, 508_B, ..., 508_{M*}, as well as one or more additional slots 1708, where each slot is large enough to accommodate a packet as described herein above. Slots 508_A, 508_B, ... and 508_{M*} are reserved for packets destined for the off-chip input queue 228 and slot(s) 1708 are reserved for system packets destined for the CPU 1400. In one specific embodiment of the invention, the data

memory 1702 includes four slots 508_A, 508_B, 508_C, 1708, where slot 508_A may be associated with a high priority class, slot 508_B may be associated with a medium priority class, slot 508_C may be associated with a low priority class and slot 1708 may be associated with a system packet of any priority destined for the CPU 1400.

The queue controller 1710 in receiver 1450_j has access control memory 1712, which comprises a plurality of entries 514_A, 514_B, ..., 514_{M*}, 1714 for storing the occupancy status (i.e., occupied or unoccupied) of the respective slots 508_A, 508_B, ..., 508_{M*}, 1708 in the data memory 1702. In addition, for each of the slots 508, 1708 that is occupied, the corresponding entry stores the priority level of the packet occupying that slot. In one embodiment, the entries 514_A, 514_B, ..., 514_{M*}, 1714 may take the form of registers, for example. In other embodiments, the fill level or vacancy status may be stored by the control memory 1712.

The packet insertion module 1704 is operable to monitor the EOP bit 368 on each word received via the forward channel 210_j in order to locate the header of newly received packets. It is recalled that the EOP bit 368 undergoes a transition (e.g., falling edge) for the word that occurs in a specific position within the packet to which it belongs. In this way, detection and monitoring of the EOP bit 368 provides the packet insertion module 1704 with an indication as to when a new packet will be received and, since the header 360 is located at the beginning of the packet, the packet insertion module 1704 will know where to find the header 360 of a newly received packet.

The packet insertion module 1704 extracts control information from the header 360 of each newly received packet. Such information includes the destination of a newly received packet and an indication as to whether the received packet is a system packet that is destined for the CPU 1400. The packet insertion module 1704 accepts packets destined for which the destination cell is cell 114_J and ignores packets for which the destination cell is not cell 114_J. The packet insertion module 1704 also determines the slot into which a received and accepted packet should be inserted.

In the case of a received packet being a system packet, such packet will not require special treatment unless the TCPU field in the header of the packet is set. If the TCPU field in the header of a system packet is indeed set, then the received packet needs to be placed into the slot reserved for system packets, which would be slot 1708 in the above example. On the other hand, if the TCPU field 1810 in the header 1860 of a system packet 1850 is not set (i.e., if only the FCPU 1820 field of the system packet is set), then the receiver 1450_j is to treat such system packet like a traffic packet.

The header 360 of a traffic packet 350 will indicate the priority level of the packet for the purposes of determining into which slot it should be placed in the data memory 1702. The packet insertion module 1704 is operable to determine the priority class of the packet by comparing the priority level of the packet to the previously defined priority thresholds. By way of example, as suggested herein above, let slots 508_A, 508_B, 508_C be associated with high, medium, and low priority levels, respectively. Also, let the low-medium priority threshold and the medium-high priority threshold be established as previously defined, namely, at 100 and 200, respectively. If the priority level of the received packet is 12, for example, then the slot into which it should be written would be slot 508_C.

In this embodiment, the packet insertion module 1704 knows that it can write the received traffic packet into slot 508_C because, it will be recalled, the packet could only be transmitted on the forward channel 210_j if the corresponding slot were available in the first place. Nonetheless, it is within the scope of the present invention to include larger numbers of slots where more than one slot would be associated with a given priority class, which may require the packet insertion module 1704 to verify the occupancy of the individual slots 508 by consulting the *queue_full* line 526 (previously described) received from the queue controller 1710.

Next, the packet insertion module 1704 determines a corresponding base address in the data memory 1702 into which the first word of the packet is to be written.

This may be done either by computing an offset which corresponds to the relative position of the chosen slot or by consulting a short lookup table that maps slots to addresses in the data memory 1702.

5 The packet insertion module 1704 is operable to provide the base address to the data memory 1702 via the *write_address* line 516 and is further operable to assert the *write_enable* line 518. At approximately the same time, the packet insertion module 504 sends a signal to the queue controller 1710 along the *new_packet* line 528 (previously described with reference to Fig. 5), such signal being
10 indicative of the identity of the slot which is being written to and the priority level of the packet which shall occupy that slot. The queue controller 1710 is adapted to process this signal by updating the status and priority information associated with the identified slot (which was previously unoccupied).

15 After the first word of the received packet is written to the above-determined base address of the data memory 1702, the address on the *write_address* line 516 is then incremented at each clock cycle (or at each multiple of a clock cycle) as new words are received along the forward channel 210_j. This will cause the words of the packet to fill the chosen slot in the data memory 1702. Meanwhile, the EOP
20 bit 368 in each received word is monitored by the packet insertion module 1704. When a new packet is detected, the above process re-starts with extraction of control information from the header 360 of the newly received packet.

In addition to being writable, the data memory 1702 is also readable in response
25 to receipt of a read address supplied along a corresponding *read_address* line 1793_j. In some embodiments where higher switching speeds are desirable, dual ported RAM may be used to allow simultaneous reading and writing, although a single-ported RAM could be used in order to reduce chip real estate. The *read_address* line 1793_j is the output of a 1x2 demultiplexer 1794 which is
30 controlled by a control signal received from the queue controller 1710 via a control line 1795. The demultiplexer 1794 also has two data inputs, one of which (denoted 1791) stems from an arbiter 260 and another of which (denoted 1792) stems from an arbiter 1760.

The arbiter 260 operates as previously described, i.e., it initiates reads from the data memory 1702 as a function of requests received from the queue controller 1710 in each of the receivers 1450 via the corresponding plurality of *request* lines 503 (previously described). A particular *request* line 503_j will be asserted if the queue controller 1710 in the corresponding receiver 1450_j is desirous of forwarding a packet to the off-chip input queue 228. In a similar fashion, the arbiter 1760 initiates reads from the data memory 1702 as a function of requests received from the queue controller 1710 in each of the receivers 1450 via a corresponding plurality of *tcpu_request* lines 1703. A particular *tcpu_request* line 1703_j will be asserted if the queue controller 1710 in the corresponding receiver 1450_j is desirous of putting a system packet into the insert RAM of the CPU 1400.

The two arbiters 260, 1760 operate in parallel and can concurrently process two different requests from two different receivers 1450. However, the queue controller 1710 in each of the receivers 1450 only allows one granted request to be processed at any given time. To enable this functionality, the following provides one possible implementation of the queue controller 1710 in receiver 1450_j which is adapted to generate up to two requests for the transmission of two packets, one for off-chip transmission of one from one of the slots 508_A, 508_B, ..., 508_M* in the data memory 1702 and one for CPU-bound transmission of one of the packets occupying the slot(s) 1708.

In the case of the request to the arbiter 260, the identity of the slot chosen to be transmitted is provided along a corresponding *slot_id* line 505_j, while the priority associated with the chosen slot is provided on a corresponding *priority* line 507_j. Specifically, the queue controller 1710 implements a function which verifies the entries in the control memory 1712 in order to determine the identity of the occupied slot which holds the highest-priority packet that can be accommodated by the off-chip input queue 228. This function can be suitably implemented by a logic circuit, for example. By way of example, the queue controller 1710 is designed to determine, amongst all occupied slots amongst slots 508 in the data memory 1702, the identity of the slot holding the highest-priority packet. The

queue controller 1710 then assesses the ability of the off-chip input queue 228 to accommodate that packet by processing information received via the *almost_full* flag 208.

5 If the *almost_full* flag 208 is asserted, then it may be desirable to refrain from requesting the transmittal of further packets to the off-chip input queue 228. In some embodiments of the invention, the *almost_full* flag 208 may consist of a plurality of *almost_full* flags, one for each priority class (high, medium, low). This allows preferential treatment for high-priority packets by setting the occupancy
10 threshold for asserting the high-priority *almost_full* flag higher than the threshold for asserting the low-priority *almost_full* flag.

If the highest-priority packet can indeed be accommodated, then the queue controller 1710 places the identity of the associated slot on the corresponding
15 *slot_id* line 505_j, places the priority level of the packet on the corresponding *priority* line 507_j and submits a request to the arbiter 260 by asserting the corresponding *request* line 503_j. However, if the highest-priority packet cannot indeed be accommodated, then the queue controller 1710 determines, among all occupied slots in the data memory 1702, the identity of the slot holding the next-
20 highest-priority packet. As before, this can be achieved by processing information received via the *almost_full* flag 208.

If the next-highest-priority packet can indeed be accommodated, then queue controller 1710 places the identity of the associated slot on the corresponding
25 *slot_id* line 505_j, places the priority level of the packet on the corresponding *priority* line 507_j and submits a request to the arbiter 260 by asserting the corresponding *request* line 503_j. However, if the next-highest-priority packet cannot indeed be accommodated, then the queue controller 1710 determines, among all occupied slots in the data memory 1702, the identity of the slot holding
30 the next-next-highest-priority packet, and so on. If none of the packets can be accommodated or, alternatively, if none of the slots are occupied, then no request is generated by the queue controller 1710 and the corresponding *request* line 503_j remains unasserted.

In the case of the request to the arbiter 1460, the identity of the slot chosen to be transmitted is provided along a corresponding *tcpu_slot_id* line 1705_j, while the priority associated with the chosen slot is provided on a corresponding *tcpu_priority* line 1707_j. There may be only one slot 1708 for holding packets destined for the insert RAM of the CPU 1400, in which case the queue controller 1710 implements a function which verifies whether this slot is occupied and whether the slot can be accommodated by the CPU 1400. This function can be suitably implemented by a logic circuit, for example. The ability of the CPU 1400 to accommodate a received packet can be assessed by way of the *cpu_almost_full* flag 1408.

If the *cpu_almost_full* flag 1408 is asserted, then it may be desirable to refrain from requesting the transmittal of further packets to the CPU 1400. On the other hand, if the *cpu_almost_full* flag 1408 is not asserted, then the queue controller 1710 places the identity of slot 1708 on the corresponding *tcpu_slot_id* line 1705_j, places the priority level of the packet on the corresponding *tcpu_priority* line 1707_j and submits a request to the arbiter 1760 by asserting the corresponding *tcpu_request* line 1703_j.

Now, assume that a request submitted by the queue controller 1710 has been granted. If this granted request had been submitted to the arbiter 260, the latter may identify the receiver containing the queue controller whose request has been granted by sending a unique code on a common *grant* line 511 and, when ready, the arbiter 260 may assert a *grant_enable* line 515 shared by the queue controller 1710 in each of the receivers 1450. The queue controller 1710 may thus establish that its request has been granted by (i) detecting a unique code in the signal received from the arbiter 260 via the *grant* line 511; and (ii) detecting the asserted *grant_enable* line 515.

In a similar fashion, if the granted request had been submitted to the arbiter 1460, the latter may identify the receiver containing the queue controller whose request has been granted by sending a unique code on a common *cpu_grant* line 1711

and, when ready, the arbiter 1460 may assert a *cpu_grant_enable* line 1715 shared by the queue controller 1710 in each of the receivers 1450. The queue controller 1710 may thus establish that its request has been granted by (i) detecting a unique code in the signal received from the arbiter 1460 via the *cpu_grant* line 1711; and (ii) detecting the asserted *cpu_grant_enable* line 1715.

Upon receipt of an indication that either or both of its requests have been granted, the queue controller 1710 processes at most one of these. In one embodiment, a granted request to arbiter 260 has priority over a granted request to arbiter 1460. Depending on which granted request is accepted, the queue controller 1710 reacts differently.

Firstly, regardless of whether the granted request was to arbiter 260 or arbiter 1460, the queue controller 1710 accesses the entry in the control memory 1712 corresponding to the slot whose packet now faces an imminent exit from the data memory 1702 under the control of the arbiter 260. Specifically, the queue controller 1710 changes the status of that particular slot to "unoccupied", which will alter the result of the request computation logic, resulting in the generation of a new request which may specify a different slot. In the case where the packet insertion module 1704 needs to know the status of a slot, the changed status of a slot will be reflected in the information provided via the *queue_full* line 526.

In the specific case where a granted request to arbiter 260 is accepted, the queue controller 1710 asserts the corresponding *pointer_update* line 529_j (previously described) which runs back to the arbiter 260. Assertion of one of the *pointer_update* lines 529_j indicates to the arbiter 260 that the grant it has issued has been acknowledged, allowing the arbiter 260 to proceed with preparing the next grant, based on a possibly new request from the queue controller 1710 in receiver 1450_j and on pending requests from queue controllers in other ones of the receivers 1450. Additionally, the queue controller 1710 controls the signal on the control line 1795 leading to the multiplexer 1794 so that the address provided along the *read_address* line 1793_j is the read address output by arbiter 260.

In the specific case where a granted request to arbiter 1460 is accepted, the queue controller 1710 asserts a corresponding *pointer_update* line 1729j which runs back to the arbiter 1460. Assertion of one of the *pointer_update* lines 1729j indicates to the arbiter 1460 that the grant it has issued has been acknowledged, allowing the arbiter 1460 to proceed with preparing the next grant, based on a possibly new request from the queue controller 1710 in receiver 1450j and on pending requests from queue controllers in other ones of the receivers 1450. Additionally, the queue controller 1710 controls the signal on the control line 1795 leading to the multiplexer 1794 so that the address provided along the *read_address* line 1793j is the read address output by arbiter 1460.

The function of the arbiter 260 is to receive a request from the queue controller 1710 in each of the receivers 1450, to grant only one of the requests and to control read operations from the data memory 1702. To this end, the arbiter 260 comprises a request-processing module 570, an address decoder 580 and a packet-forwarding module 590. The arbiter 260 is identical to the arbiter 260 previously described with reference to Fig. 5 and therefore no further description is necessary.

Similarly, the function of the arbiter 1460 is to receive a request from the queue controller 1710 in each of the receivers 1450, to grant only one of the requests and to control read operations from the data memory 1702. To this end, the arbiter 1460 comprises a request-processing module 1770, an address decoder 1780 and a packet-forwarding module 1790. The arbiter 1460 is very similar to the arbiter 260 previously described with reference to Fig. 5, with a minor variation in the implementation of the address decoder 1780.

Specifically, the address decoder 1780 receives the *cpu_grant* line 1711 from the request-processing module 1770 but and the *slot_id* lines 1705 from the queue controllers 1710 in the various receivers 1450. The address decoder 1780 computes a base address in the data memory 1702 that stores the first word of the system packet for which transmission has been granted. The base address is computed as a function of the code specified on the *cpu_grant* line 1711. The

base address is provided to the packet-forwarding module 1790 via a *base_address* line 1782.

5 Of course, those skilled in the art will appreciate that cells could be adapted in order to provide both multicast functionality and system packet transmission / reception functionality.

Moreover, as used herein, the term "memory" should be understood to refer to any data storage capability, either distributed, or in one single block.

10

While specific embodiments of the present invention have been described and illustrated, it will be apparent to those skilled in the art that numerous modifications and variations can be made without departing from the scope of the invention as defined in the appended claims.

Claims:

1) A switch fabric implemented on a chip, comprising:

a) an array of cells;

b) an I/O interface in communication with said array of cells for permitting exchange of data packets between said array of cells and components external to said array of cells;

c) each cell including:

I) a transmitter in communication with said I/O interface and in communication with every other cell of said array, said transmitter operative to process a data packet received from said I/O interface to determine a destination of the data packet and forward the data packet to at least one cell of said array selected on a basis of the determined destination;

II) a plurality of receivers associated with respective cells from said array, each receiver being in communication with a respective cell allowing the respective cell to forward data packets to the receiver;

III) said receivers in communication with said I/O interface for releasing data packets to said I/O interface.

2) A switch fabric as defined in claim 1, wherein said array of cells includes a plurality of data channels, each data channel being associated with a given cell, the data channel associated with said given cell connecting the transmitter of said given cell to receivers in cells other than said given cell and associated with said given cell.

3) A switch fabric as defined in claim 2, wherein the data channel associated with said given cell connects the transmitter of said given cell to a receiver in every cell of said array and associated with said given cell.

4) A switch fabric as defined in claim 3, wherein the plurality of data channels are independent from one another, wherein transmission of a data packet over one

data channel is made independently of a transmission of a data packet over another data channel.

- 5 5) A switch fabric as defined in claim 4, wherein each data channel performs a parallel data transfer.
- 6) A switch fabric as defined in claim 2, wherein said array of cells forms a matrix.
- 7) A switch fabric as defined in claim 6, wherein said matrix is bi-dimensional.
- 10 8) A switch fabric as defined in claim 7, wherein said matrix is three-dimensional.
- 9) A switch fabric as defined in claim 2, wherein said array of cells forms a toroidal mesh arrangement.
- 15 10) A switch fabric as defined in claim 2, wherein the transmitter of said given cell includes a memory for storing data packets received from said I/O interface.
- 11) A switch fabric as defined in claim 10, wherein said memory includes a plurality of segments, each segment being associated with a receiver in a cell of said array to which the transmitter of said given cell is capable of forwarding a data packet via the data channel associated with said given cell.
- 20 12) A switch fabric as defined in claim 11, wherein the transmitter of said given cell includes a control entity that processes a data packet forwarded from said I/O interface to determine a cell of said array to which the packet is destined and identify on a basis of the determined cell a segment of said memory into which the packet is to be loaded.
- 25 13) A switch fabric as defined in claim 12, wherein said control entity includes a plurality of queue controllers associated with respective segments of said memory.
- 30

14)A switch fabric as defined in claim 13, wherein said memory implements a plurality of registers, each register being associated with a queue controller and being suitable for holding data representative of a degree of occupancy of a segment of said memory associated with the queue controller.

5

15)A switch fabric as defined in claim 14, wherein a data packet received by said transmitter from said I/O interface is characterized by a priority level selected from a group of priority levels, each segment of said memory being partitioned into slots, each slot being capable of storing at least one data packet, each slot being associated with a given priority level of said group of priority levels.

10

16)A switch fabric as defined in claim 15, wherein the registers of said memory associated with each queue controller store data indicative of a degree of occupancy of the slots of said segment associated with the queue controller, for each priority level of the group of priority levels.

15

17)A switch fabric as defined in claim 12, wherein the transmitter of said given cell communicates with each receiver associated with said given cell to assess a degree of occupancy of each receiver associated with said given cell.

20

18)A switch fabric as defined in claim 17, wherein the transmitter of said given cell communicates with each receiver associated with said given cell to assess the degree of occupancy of each receiver associated with said given cell over a back channel.

25

19)A switch fabric as defined in claim 18, including a plurality of back channels, there being a dedicated back channel between the transmitter of said given cell and each receiver associated with said given cell.

30

20)A switch fabric as defined in claim 19, wherein each back channel transfers data serially.

21)A switch fabric as defined in claim 18, wherein said memory includes an area for storing data indicative of the degree of occupancy of each receiver associated with said given cell.

5 22)A switch fabric as defined in claim 21, wherein said control entity is operative to process the data indicative of the degree of occupancy of each receiver associated with said given cell to determine which data packet stored in said memory is suitable for transmission to a receiver.

10 23)A switch fabric as defined in claim 22, wherein said control entity determines that a data packet is suitable for transmission to a certain receiver when the data indicative of the degree of occupancy of the certain receiver indicates that the receiver is capable of accepting the data packet.

15 24)A switch fabric as defined in claim 23, wherein when said control entity determines that a data packet is suitable for transmission, said control entity generates a control signal to request transmission of the data packet.

20 25)A switch fabric as defined in claim 24, wherein when said control entity determines that a plurality of data packets are suitable for transmission, said control entity generates a plurality of control signals to request transmission of the data packets, each control signal being associated with a data packet.

25 26)A switch fabric as defined in claim 25, wherein said control entity includes an arbiter for processing said control signals to select a data packet to transmit among the plurality of data packets suitable for transmission.

30 27)A switch fabric as defined in claim 26, wherein a data packet is characterized by a priority level, wherein each control signal conveys the priority level of the data packet associated with the control signal.

28)A switch fabric as defined in claim 27, wherein said arbiter selects a data packet to transmit among the plurality of data packets suitable for transmission

on a basis of the priority levels of the plurality of data packets suitable for transmission.

5 29)A switch fabric as defined in claim 28 wherein said arbiter processes control signals to request transmission of data packets in a round robin manner.

10 30)A switch fabric as defined in claim 29, wherein said arbiter selects a data packet to transmit among the plurality of data packets suitable for transmission on a basis of the priority levels of the plurality of data packets suitable for transmission and on the basis of whether or not a data packet was previously submitted for transmission.

15 31)A switch fabric as defined in claim 10, wherein said memory is a first memory, said cell comprising a second memory including a plurality of sectors associated with respective receivers of said plurality of receivers, said sectors being capable of storing data packets forwarded to said receivers by cells of said array.

20 32)A switch fabric as defined in claim 31, wherein each receiver of said plurality of receivers communicates with said I/O interface.

25 33)A switch fabric as defined in claim 31, wherein said plurality of receivers includes a control entity to regulate a release of data packets from said sectors to said I/O interface.

34)A switch fabric as defined in claim 33, wherein said control entity includes a plurality of queue controllers associated with respective sectors of said memory.

30 35)A switch fabric as defined in claim 34, wherein a data packet received by a receiver of said plurality of receivers is characterized by a priority level selected from a group of priority levels, each sector of said second memory being divided into subdivisions, each subdivision being capable of storing at

least one data packet, each subdivision being associated with a given priority level of said group of priority levels.

5 36)A switch fabric as defined in claim 35, wherein said control entity includes an arbiter in communication with said queue controllers, each queue controller being operative to transmit a control signal to said arbiter for each data packet held in the sector associated with the queue controller to request release of the data packet to said I/O interface.

10 37)A switch fabric as defined in claim 36, wherein each control signal conveys the priority level of the data packet associated with the control signal.

15 38)A switch fabric as defined in claim 37, wherein said arbiter selects a data packet for release to said I/O interface among the data packets corresponding to the control signals transmitted to said arbiter on the basis of the levels of priority of the data packets corresponding to the control signals transmitted to said arbiter.

20 39)A switch fabric as defined in claim 1, wherein each data packet comprises a plurality of words including a first word of said data packet and a last word of said data packet, wherein each word comprises a field indicative of whether said word is a pre-determined number of words away from said last word of said data packet.

25 40)A switch fabric as defined in claim 39, wherein the transmitter is operative to monitor said field in each word of each data packet forwarded to at least one cell of said array, the transmitter further being operative to begin forwarding a next data packet upon detecting that said field of a word in a packet currently being forwarded is indicative of said word being a pre-determined number of
30 words away from the last word of said data packet currently being forwarded.

41)A switch fabric as defined in claim 1, each cell further including a central processing unit (CPU) connected to the transmitter, said transmitter being

further operative to process a data packet received from said CPU to determine a destination of the data packet and forward the data packet to at least one cell of said array selected on the basis of the determined destination.

5 42)A switch fabric as defined in claim 2, each cell further including a central processing unit (CPU) connected to the transmitter, said transmitter being further operative to process a data packet received from said CPU to determine a destination of the data packet and forward the data packet to at least one cell of said array selected on the basis of the determined destination,
10 wherein data packets received by the transmitter in a given cell from the I/O interface and from the CPU in said given cell share the data channel associated with said given cell.

15 43)A switch fabric as defined in claim 1, each cell further including a central processing unit (CPU) connected to the plurality of receivers, said receivers being further operative to determine whether data packets are to be released to the I/O interface or to the CPU and release said data packets accordingly.

20 44)A switch fabric as claimed in claim 43, wherein each data packet comprises a field indicative of whether the data packet is destined for a CPU and wherein said receivers are operative to determine whether data packets are to be released to the I/O interface or to the CPU on the basis of said field.

25 45)A switch fabric as defined in claim 25, each cell further including a central processing unit (CPU) connected to the plurality of receivers, wherein said control entity includes a first arbiter for processing said control signals to select a data packet to transmit to the I/O interface among the plurality of data packets suitable for transmission to the I/O interface, wherein said control entity includes a second arbiter for processing said control signals to select a
30 data packet to transmit to the CPU among the plurality of data packets suitable for transmission to the CPU.

46)A switch fabric as defined in claim 1, wherein the transmitter of said given cell includes a memory for storing data packets received from said I/O interface.

5 47)A switch fabric as defined in claim 46, wherein said memory includes a plurality of segments, each segment being associated with a receiver in a cell of said array in which the transmitter of said given cell is capable of forwarding a data packet via the data channel associated with said given cell.

48)A switch fabric implemented on a chip, comprising:

10 a) an array of cells;

b) an I/O interface in communication with said array of cells for permitting exchange of data packets between said array of cells and components external to said array of cells;

15 c) each cell communicating with at least one other cell of said array permitting exchange of data packets between the cells of said array;

d) each cell including:

1) a memory for receiving a data packet from another cell of said array;

20 II) a control entity to control release of a data packet toward a selected destination cell of said array at least in part on a basis of a degree of occupancy of the memory in said destination cell.

49)A switch fabric as defined in claim 48, wherein each cell of said array includes:

25 a) a transmitter in communication with said I/O interface and in communication with every other cell of said array, said transmitter operative to process a data packet received from said I/O interface to determine a destination of the data packet and forward the data packet to at least one cell of said array selected on a basis of the determined destination;

30 b) a plurality of receivers associated with respective cells from said array, each receiver being in communication with a respective cell allowing the respective cell to forward data packets to the receiver;

c) said receivers in communication with said I/O interface for releasing data packets to said I/O interface.

50)A switch fabric as defined in claim 49, wherein said array of cells includes a plurality of data channels, each data channel being associated with a given cell, the data channel associated with said given cell connecting the transmitter of said given cell to receivers in cells other than said given cell and associated with said given cell.

51)A switch fabric as defined in claim 49, wherein said array of cells includes a plurality of data channels, each data channel being associated with a given cell, the data channel associated with said given cell connecting the transmitter of said given cell to a receiver in every cell of said array of cells and associated with said given cell.

52)A switch fabric as defined in claim 51, wherein the plurality of data channels are independent from one another, wherein transmission of a data packet over one data channel is made independently of a transmission of a data packet over another data channel.

53)A switch fabric as defined in claim 52, wherein each data channel performs a parallel data transfer.

54)A switch fabric as defined in claim 48, wherein said array of cells forms a matrix.

55)A switch fabric as defined in claim 54, wherein said matrix is bi-dimensional.

56)A switch fabric as defined in claim 54, wherein said matrix is three-dimensional.

57)A switch fabric as defined in claim 48, wherein said array of cells forms a toroidal mesh arrangement.

58)A switch fabric as defined in claim 49, wherein said memory is a first memory and wherein the transmitter of said given cell includes a second memory for storing data packets received from said I/O interface.

5 59)A switch fabric as defined in claim 58, wherein said second memory includes a plurality of segments, each segment being associated with a receiver in a cell of said array to which the transmitter of said given cell is capable of forwarding a data packet via the data channel.

10 60)A switch fabric as defined in claim 59, wherein the transmitter of said given cell includes said control entity, said control entity being operative to process a data packet forwarded from said I/O interface to determine a cell of said array to which the data packet is destined and identify on a basis of the determined cell a segment of said second memory into which the packet is to be loaded.

15

61)A switch fabric as defined in claim 60, wherein said control entity includes a plurality of queue controllers associated with respective segments of said second memory.

20 62)A switch fabric as defined in claim 61, wherein said second memory implements a plurality of registers, each register being associated with a queue controller and being suitable for holding data representative of a degree of occupancy of a segment of said second memory associated with the queue controller.

25

63)A switch fabric as defined in claim 62, wherein a data packet received by said transmitter from said I/O interface is characterized by a priority level selected in a group of priority levels, each segment of said second memory being partitioned into slots, each slot capable of storing at least one data packet, each slot being associated with a given priority level of said group of priority levels.

30

64)A switch fabric as defined in claim 63, wherein the registers of said second memory associated with each queue controller store data indicative of a degree of occupancy of the slots of said segment associated with the queue controller, for each priority level of the group of priority levels.

5

65)A switch fabric as defined in claim 60, wherein said first memory is divided into a plurality of sectors associated with respective ones of said receivers, said sectors capable of storing data packets forwarded to said receivers by cells of said array, said control entity being operative to communicate with each receiver associated with said given cell to assess a degree of occupancy of the sector of each receiver associated with said given cell.

10

66)A switch fabric as defined in claim 65, wherein said control entity communicates with each receiver associated with said given cell to assess the degree of occupancy of the sector of each receiver associated with said given cell, over a back channel.

15

67)A switch fabric as defined in claim 66, including a plurality of back channels, there being a dedicated back channel between said control entity and each receiver associated with said given cell.

20

68)A switch fabric as defined in claim 67, wherein each back channel transfers data serially.

25

69)A switch fabric as defined in claim 66, wherein said second memory includes an area for storing data indicative of the degree of occupancy of the sector of each receiver associated with said given cell.

30

70)A switch fabric as defined in claim 69, wherein said control entity is operative to process the data indicative of the degree of occupancy of the sector of each receiver associated with said given cell to determine which data packet stored in said second memory is suitable for transmission to a receiver.

71)A switch fabric as defined in claim 70, wherein when said control entity determines that a data packet is suitable for transmission, said control entity generates a control signal to request transmission of the data packet.

5 72)A switch fabric as defined in claim 71, wherein when said control entity determines that a plurality of data packets are suitable for transmission, said control entity generates a plurality of control signals to request transmission of the data packets, each control signal being associated with a data packet.

10 73)A switch fabric as defined in claim 72, wherein said control entity includes an arbiter for processing said control signals to select a data packet to transmit among the plurality of data packets suitable for transmission.

15 74)A switch fabric as defined in claim 73, wherein a data packet is characterized by a priority level, wherein each control signal conveys the priority level of the data packet associated with the control signal.

20 75)A switch fabric as defined in claim 74, wherein said arbiter selects a data packet to transmit among the plurality of data packets suitable for transmission on a basis of the priority levels of the plurality of data packets suitable for transmission.

25 76)A switch fabric as defined in claim 75, wherein said arbiter processes control signals to request transmission of data packets in a round robin manner.

30 77)A switch fabric as defined in claim 76, wherein said arbiter selects a data packet to transmit among the plurality of data packets suitable for transmission on a basis of the priority levels of the plurality of data packets suitable for transmission and on the basis of whether or not a data packet was previously submitted for transmission.

78)A switch fabric as defined in claim 65, wherein each receiver of said plurality of receivers communicates with said I/O interface.

79)A switch fabric as defined in claim 78, wherein said control entity is a first control entity and wherein said plurality of receivers include a second control entity to regulate a release of data packets from said sectors to said I/O interface.

5

80)A switch fabric as defined in claim 79, wherein said second control entity includes a plurality of queue controllers associated with respective sectors of said first memory.

10

81)A switch fabric as defined in claim 80, wherein a data packet received by a receiver of said plurality of receivers is characterized by a priority level selected in a group of priority levels, each sector of said second memory being divided into subdivisions, each subdivision capable of storing at least one data packet, each subdivision being associated with a given priority level of said group of priority levels.

15

82)A switch fabric as defined in claim 81, wherein said second control entity includes an arbiter in communication with said queue controllers, each queue controller operative to transmit a control signal to said arbiter for each data packet held in the sector associated with the queue control to request release of the data packet to said I/O interface.

20

83)A switch fabric as defined in claim 82, wherein each control signal conveys the priority level of the data packet associated with the control signal.

25

84)A switch fabric as defined in claim 83, wherein said arbiter selects a data packet for release to said I/O interface among the data packets corresponding to the control signals transmitted to said arbiter on the basis of the levels of priority of the data packets corresponding to the control signals transmitted to said arbiter.

30

85)A switch fabric as defined in claim 49, wherein each data packet comprises a plurality of words including a first word of said data packet and a last word of said data packet, wherein each word comprises a field indicative of whether said word is a pre-determined number of words away from said last word of said data packet.

86)A switch fabric as defined in claim 85, wherein the transmitter is operative to monitor said field in each word of each data packet forwarded to at least one cell of said array, the transmitter further being operative to begin forwarding a next data packet upon detecting that said field of a word in a packet currently being forwarded is indicative of said word being a pre-determined number of words away from the last word of said data packet currently being forwarded.

87)A switch fabric as defined in claim 49, each cell further including a central processing unit (CPU) connected to the transmitter, said transmitter being further operative to process a data packet received from said CPU to determine a destination of the data packet and forward the data packet to at least one cell of said array selected on the basis of the determined destination.

88)A switch fabric as defined in claim 50, each cell further including a central processing unit (CPU) connected to the transmitter, said transmitter being further operative to process a data packet received from said CPU to determine a destination of the data packet and forward the data packet to at least one cell of said array selected on the basis of the determined destination, wherein data packets received by the transmitter in a given cell from the I/O interface and from the CPU in said given cell share the data channel associated with said given cell.

89)A switch fabric as defined in claim 49, each cell further including a central processing unit (CPU) connected to the plurality of receivers, said receivers being further operative to determine whether data packets are to be released to the I/O interface or to the CPU and release said data packets accordingly.

90)A switch fabric as claimed in claim 89, wherein each data packet comprises a field indicative of whether the data packet is destined for a CPU and wherein said receivers are operative to determine whether data packets are to be released to the I/O interface or to the CPU on the basis of said field.

5

91)A switch fabric as defined in claim 72, each cell further including a central processing unit (CPU) connected to the plurality of receivers, wherein said control entity includes a first arbiter for processing said control signals to select a data packet to transmit to the I/O interface among the plurality of data packets suitable for transmission to the I/O interface, wherein said control entity includes a second arbiter for processing said control signals to select a data packet to transmit to the CPU among the plurality of data packets suitable for transmission to the CPU.

10

15 92)A switch fabric implemented on a chip comprising:

- a) an array of cells; and
- b) an I/O interface in communication with said array of cells permitting exchange of data packets between said array of cells and components external to said array of cells;
- 20 c) each cell communicating with at least one other cell of said array permitting exchange of data packets between the cells of said array;
- d) each cell including:
 - I) a memory for holding a plurality of data packets for transmission to other cells of said array, each data packet of the plurality of data packets having a characteristic element represented by a parameter, the parameter allowing to distinguish one data packet from another data packet in the plurality of data packets; and
 - 25 II) a control entity operative to:
 - (i) select at least one data packet from the plurality of data packets at least in part on a basis of the parameter; and
 - 30 (ii) transmit the selected data packet to another cell of said array of cells.

25

30

93)A switch fabric as defined in claim 92, wherein the parameter is priority, the characteristic element being a priority level.

94)A switch fabric as defined in claim 93, wherein each cell of said array includes:

- 5 a) a transmitter in communication with said I/O interface and in communication with every other cell of said array, said transmitter operative to process a data packet received from said I/O interface to determine a destination of the data packet and forward the data packet to at least one cell of said array selected on a basis of the determined destination;
- 10 b) a plurality of receivers associated with respective cells from said array, each receiver being in communication with a respective cell allowing the respective cell to forward data packets to the receiver;
- c) said receivers in communication with said I/O interface for releasing data packets to said I/O interface.

15

95)A switch fabric as defined in claim 94, wherein said array of cells includes a plurality of data channels, each data channel being associated with a given cell, the data channel associated with said given cell connecting the transmitter of said given cell to receivers in cells other than said given cell and associated with said given cell.

20

96)A switch fabric as defined in claim 94, wherein the data channel associated with said given cell connects the transmitter of said given cell to a receiver in every cell of said array of cells and associated with said given cell.

25

97)A switch fabric as defined in claim 96, wherein the plurality of data channels are independent from one another, wherein transmission of a data packet over one data channel is made independently of a transmission of a data packet over another data channel.

30

98)A switch fabric as defined in claim 97, wherein each data channel performs a parallel data transfer.

99) A switch fabric as defined in claim 98, wherein said memory and said control entity form part of said transmitter.

5 100) A switch fabric as defined in claim 99, wherein said memory includes a plurality of segments, each segment being associated with a receiver in a cell of said array to which the transmitter of said given cell is capable of forwarding a data packet via the data channel.

10 101) A switch fabric as defined in claim 100, wherein said control entity is operative to process a data packet forwarded from said I/O interface to determine a cell of said array to which the data packet is destined and identify on a basis of the determined cell a segment of said memory into which the packet is to be loaded.

15 102) A switch fabric as defined in claim 101, wherein said control entity includes a plurality of queue controllers associated with respective segments of said memory.

20 103) A switch fabric as defined in claim 102, wherein said memory implements a plurality of registers, each register being associated with a queue controller and being suitable for holding data representative of a degree of occupancy of a segment of said memory associated with the queue controller.

25 104) A switch fabric as defined in claim 103, wherein each segment of said memory is partitioned in slots, each slot capable of storing at least one data packet, each slot being associated with a given priority level of said group of priority levels.

30 105) A switch fabric as defined in claim 104, wherein the registers of said memory associated with each queue controller store data indicative of a degree of occupancy of the slots of said segment associated with the queue controller, for each priority level of the group of priority levels.

106) A switch fabric as defined in claim 105, wherein the transmitter of said given cell communicates with each receiver associated with said given cell to assess a degree of occupancy of each receiver associated with said given cell.

5 107) A switch fabric as defined in claim 106, wherein the transmitter of said given cell communicates with each receiver associated with said given cell to assess the degree of occupancy of each receiver associated with said given cell over a back channel.

10 108) A switch fabric as defined in claim 107, including a plurality of back channels, there being a dedicated back channel between the transmitter of said given cell and each receiver associated with said given cell.

15 109) A switch fabric as defined in claim 108, wherein each back channel transfers data serially.

20 110) A switch fabric as defined in claim 109, wherein said memory includes an area for storing data indicative of the degree of occupancy of each receiver associated with said given cell.

25 111) A switch fabric as defined in claim 110, wherein said control entity is operative to process the data indicative of the degree of occupancy of each receiver associated with said given cell to determine which data packet stored in said memory is suitable for transmission to a receiver.

30 112) A switch fabric as defined in claim 111, wherein said control entity determines that a data packet is suitable for transmission to a certain receiver when the data indicative of the degree of occupancy of the certain receiver indicates that the receiver is capable of accepting the data packet.

113) A switch fabric as defined in claim 112, wherein when said control entity determines that a group of data packets are suitable for transmission, said

control entity generates a plurality of control signals to request transmission of the data packets, each control signal being associated with a data packet.

5 114) A switch fabric as defined in claim 113, wherein said control entity includes an arbiter for processing said control signals to select a data packet to transmit among the group of data packets suitable for transmission.

115) A switch fabric as defined in claim 114, wherein each control signal conveys the priority level of the data packet associated with the control signal.

10 116) A switch fabric as defined in claim 115, wherein said arbiter selects a data packet to transmit among the group of data packets suitable for transmission on a basis of the priority levels of the group of data packets suitable for transmission.

15 117) A switch fabric as defined in claim 116, wherein said arbiter processes control signals to request transmission of data packets in a round robin manner.

20 118) A switch fabric as defined in claim 117, wherein said arbiter selects a data packet to transmit among the group of data packets suitable for transmission on a basis of the priority levels of the packets in the group of data packets suitable for transmission and on the basis of whether or not a data packet was previously submitted for transmission.

25 119) A switch fabric as defined in claim 97, wherein said memory is a first memory, said switch fabric including a second memory wherein said second memory includes a plurality of sectors associated with respective receivers of said plurality of receivers, said sectors capable of storing data packets
30 forwarded to said receivers by cells of said array.

120) A switch fabric as defined in claim 119, wherein each receiver of said plurality of receivers communicates with said I/O interface.

121) A switch fabric as defined in claim 120, wherein said control entity is a first control entity, said switch fabric including a second control entity to regulate a release of data packets from said sectors to said I/O interface.

5

122) A switch fabric as defined in claim 121, wherein said second control entity includes a plurality of queue controllers associated with respective sectors of said second memory.

10

123) A switch fabric as defined in claim 122, wherein a data packet received by a receiver of said plurality of receivers is characterized by a priority level selected in a group of priority levels, each sector of said second memory being divided in subdivisions each subdivision capable of storing at least one data packet, each subdivision being associated with a given priority level of said group of priority levels.

15

124) A switch fabric as defined in claim 123, wherein said second control entity includes an arbiter in communication with said queue controllers, each queue controller operative to transmit a control signal to the arbiter of said second control entity for each data packet held in the sector associated with the queue controller to request release of the data packet to said I/O interface.

20

125) A switch fabric as defined in claim 124, wherein each control signal conveys the priority level of the data packet associated with the control signal.

25

126) A switch fabric as defined in claim 125, wherein said arbiter selects a data packet for release to said I/O interface among the data packets corresponding to the control signals transmitted to the arbiter of said second control entity on the basis of the levels of priority of the data packets corresponding to the control signals.

30

127) A switch fabric as defined in claim 92, wherein said control entity is operative to alter the parameters associated with respective data packets of the plurality of data packets.

5 128) A switch fabric as defined in claim 93, wherein said control entity is operative to alter the priority levels associated with respective data packets of said plurality of data packets.

10 129) A switch fabric as defined in claim 128, wherein said control entity is operative to alter the priority level associated with a given data packet of said plurality of data packets at least in part on a basis of a time of residence of the given data packet in said memory.

15 130) A switch fabric as defined in claim 129, wherein said control entity is operative to alter the priority level associated with the given data packet according to a function that relates the priority level of the given data packet to the time of residence of the data packet, the function selected in the group consisting of linear function, exponential function and logarithmic function.

20 131) A switch fabric as defined in claim 94, wherein each data packet comprises a plurality of words including a first word of said data packet and a last word of said data packet, wherein each word comprises a field indicative of whether said word is a pre-determined number of words away from said last word of said data packet.

25 132) A switch fabric as defined in claim 131, wherein the transmitter is operative to monitor said field in each word of each data packet forwarded to at least one cell of said array, the transmitter further being operative to begin forwarding a next data packet upon detecting that said field of a word in a packet currently
30 being forwarded is indicative of said word being a pre-determined number of words away from the last word of said data packet currently being forwarded.

133) A switch fabric as defined in claim 94, each cell further including a central processing unit (CPU) connected to the transmitter, said transmitter being further operative to process a data packet received from said CPU to determine a destination of the data packet and forward the data packet to at least one cell of said array selected on the basis of the determined destination.

134) A switch fabric as defined in claim 95, each cell further including a central processing unit (CPU) connected to the transmitter, said transmitter being further operative to process a data packet received from said CPU to determine a destination of the data packet and forward the data packet to at least one cell of said array selected on the basis of the determined destination, wherein data packets received by the transmitter in a given cell from the I/O interface and from the CPU in said given cell share the data channel associated with said given cell.

135) A switch fabric as defined in claim 94, each cell further including a central processing unit (CPU) connected to the plurality of receivers, said receivers being further operative to determine whether data packets are to be released to the I/O interface or to the CPU and release said data packets accordingly.

136) A switch fabric as claimed in claim 135, wherein each data packet comprises a field indicative of whether the data packet is destined for a CPU and wherein said receivers are operative to determine whether data packets are to be released to the I/O interface or to the CPU on the basis of said field.

137) A switch fabric as defined in claim 113, each cell further including a central processing unit (CPU) connected to the plurality of receivers, wherein said control entity includes a first arbiter for processing said control signals to select a data packet to transmit to the I/O interface among the plurality of data packets suitable for transmission to the I/O interface, wherein said control entity includes a second arbiter for processing said control signals to select a data packet to transmit to the CPU among the plurality of data packets suitable for transmission to the CPU.

138) A switch fabric implemented on a chip, comprising:

- a) an array of cells;
- b) an I/O interface in communication with said array of cells for permitting exchange of data packets between said array of cells and components external to said array of cells;
- c) each cell communicating with at least one other cell of said array, permitting:
 - I) exchange of data packets between the cells of said array;
 - II) exchange of control information between the cells of said array;
- d) each cell operative to control transmission of data packets to other cells of said array at least in part on a basis of the control information.

139) A switch fabric as defined in claim 138, wherein said array of cells includes:

- a) a plurality of data channels for transporting data packets between the cells of said array; and
- b) a plurality of channels distinct from said data channels for conveying the control information to the cells of said array.

140) A switch fabric as defined in claim 139, wherein each of the channels of the plurality of channels distinct from said data channels interconnects two cells of said array.

141) A switch fabric as defined in claim 140, wherein each cell of said array includes:

- a) a transmitter in communication with said I/O interface and in communication with every other cell of said array, said transmitter operative to process a data packet received from said I/O interface to determine a destination of the data packet and forward the data packet to at least one cell of said array selected on a basis of the determined destination;
- b) a plurality of receivers associated with respective cells of said array, each receiver being in communication with a respective cell allowing the respective cell to forward data packets to the receiver;

c) said receivers in communication with said I/O interface for releasing data packets to said I/O interface.

5 142) A switch fabric as defined in claim 141, wherein each data channel of said plurality of data channels is associated with a given cell of said array, the data channel associated with said given cell connecting the transmitter of said given cell to receivers in cells other than said given cell and associated with said given cell.

10 143) A switch fabric as defined in claim 141, wherein each data channel of said plurality of data channels is associated with a given cell of said array, the data channel associated with said given cell connecting the transmitter of said given cell to a receiver in every cell of said array of cells and associated with said given cell.

15 144) A switch fabric as defined in claim 143, wherein the plurality of data channels are independent from one another, wherein transmission of a data packet over one data channel is made independently of transmission of a data packet over another data channel.

20 145) A switch fabric as defined in claim 144, wherein each data channel performs a parallel data transfer.

25 146) A switch fabric as defined in claim 145, wherein the transmitter of said given cell includes a memory for storing data packets received from said I/O interface.

30 147) A switch fabric as defined in claim 144, wherein said memory includes a plurality of segments, each segment being associated with a receiver in a cell of said array to which the transmitter of said given cell is capable of forwarding a data packet via a data channel from said plurality of data channels.

148) A switch fabric as defined in claim 147, wherein the transmitter of said given cell includes a control entity, said control entity being operative to process a data packet forwarded from said I/O interface to determine a cell of said array to which the data packet is destined and identify on a basis of the determined cell a segment of said memory in which the packet is to be loaded.

149) A switch fabric as defined in claim 148, wherein said control entity includes a plurality of queue controllers associated with respective segments of said memory.

150) A switch fabric as defined in claim 149, wherein said memory implements a plurality of registers, each register being associated with a queue controller and being suitable for holding data representative of a degree of occupancy of a segment of said memory associated with the queue controller.

151) A switch fabric as defined in claim 150, wherein a data packet received by said transmitter from said I/O interface is characterized by a priority level selected in a group of priority levels, each segment of said memory being partitioned into slots, each slot capable of storing at least one data packet, each slot being associated with a given priority level of said group of priority levels.

152) A switch fabric as defined in claim 151, wherein the registers of said memory associated with each queue controller store data indicative of a degree of occupancy of the slots of said segment associated with the queue controller, for each priority level of the group of priority levels.

153) A switch fabric as defined in claim 152, wherein said memory is a first memory; wherein each cell includes a second memory, said second memory being divided into a plurality of sectors corresponding to respective ones of the receivers associated with the cell, said sectors capable of storing data packets forwarded to the receivers; and wherein the control information is passed between said control entity and each receiver associated with said given cell

and is indicative of a degree of occupancy of the sector corresponding to each receiver associated with said given cell.

5 154) A switch fabric as defined in claim 153, wherein said control entity communicates with each receiver associated with said given cell via a channel from said plurality of channels distinct from said data channels to receive the control information.

10 155) A switch fabric as defined in claim 154, wherein said plurality of channels distinct from said data channels are back channels, there being a dedicated back channel between said control entity and respective receivers associated with said given cell.

15 156) A switch fabric as defined in claim 155, wherein each back channel transfers data serially.

20 157) A switch fabric as defined in claim 156, wherein said first memory includes an area for storing data derived from the control information, indicative of the degree of occupancy of the sectors of receivers associated with said given cell.

25 158) A switch fabric as defined in claim 157, wherein said control entity is operative to process the data derived from the control information to determine which data packet stored in said first memory is suitable for transmission to a receiver.

30 159) A switch fabric as defined in claim 158, wherein when said control entity determines that a data packet is suitable for transmission, said control entity generates a control signal to request transmission of the data packet.

160) A switch fabric as defined in claim 159, wherein when said control entity determines that a plurality of data packets are suitable for transmission, said

control entity generates a plurality of control signals to request transmission of the data packets, each control signal being associated with a data packet.

5 161) A switch fabric as defined in claim 160, wherein said control entity includes an arbiter for processing said control signals to select a data packet to transmit among the plurality of data packets suitable for transmission.

10 162) A switch fabric as defined in claim 161, wherein a data packet is characterized by a priority level, wherein each control signal conveys the priority level of the data packet associated with the control signal.

15 163) A switch fabric as defined in claim 162, wherein said arbiter selects a data packet to transmit among the plurality of data packets suitable for transmission at least in part on a basis of the priority levels of the plurality of data packets suitable for transmission.

20 164) A switch fabric as defined in claim 163, wherein said arbiter processes control signals to request transmission of data packets in a round robin manner.

25 165) A switch fabric as defined in claim 164, wherein said arbiter selects a data packet to transmit among the plurality of data packets suitable for transmission on a basis of the priority levels of the plurality of data packets suitable for transmission and on the basis of whether or not a data packet was previously submitted for transmission.

166) A switch fabric as defined in claim 165, wherein each receiver of said plurality of receivers communicates with said I/O interface.

30 167) A switch fabric as defined in claim 166, wherein said control entity is a first control entity, the plurality of receivers of each cell include a second control entity to regulate a release of data packets from the sectors of the receivers to said I/O interface.

- 5 168) A switch fabric as defined in claim 141, wherein each data packet comprises a plurality of words including a first word of said data packet and a last word of said data packet, wherein each word comprises a field indicative of whether said word is a pre-determined number of words away from said last word of said data packet.
- 10 169) A switch fabric as defined in claim 168, wherein the transmitter is operative to monitor said field in each word of each data packet forwarded to at least one cell of said array, the transmitter further being operative to begin forwarding a next data packet upon detecting that said field of a word in a packet currently being forwarded is indicative of said word being a pre-determined number of words away from the last word of said data packet currently being forwarded.
- 15 170) A switch fabric as defined in claim 141, each cell further including a central processing unit (CPU) connected to the transmitter, said transmitter being further operative to process a data packet received from said CPU to determine a destination of the data packet and forward the data packet to at least one cell of said array selected on the basis of the determined destination.
- 20 171) A switch fabric as defined in claim 142, each cell further including a central processing unit (CPU) connected to the transmitter, said transmitter being further operative to process a data packet received from said CPU to determine a destination of the data packet and forward the data packet to at least one cell of said array selected on the basis of the determined destination, wherein data packets received by the transmitter in a given cell from the I/O interface and from the CPU in said given cell share the data channel associated with said given cell.
- 25 172) A switch fabric as defined in claim 141, each cell further including a central processing unit (CPU) connected to the plurality of receivers, said receivers being further operative to determine whether data packets are to be released to the I/O interface or to the CPU and release said data packets accordingly.
- 30

173) A switch fabric as claimed in claim 172, wherein each data packet comprises a field indicative of whether the data packet is destined for a CPU and wherein said receivers are operative to determine whether data packets are to be released to the I/O interface or to the CPU on the basis of said field.

174) A switch fabric as defined in claim 160, each cell further including a central processing unit (CPU) connected to the plurality of receivers, wherein said control entity includes a first arbiter for processing said control signals to select a data packet to transmit to the I/O interface among the plurality of data packets suitable for transmission to the I/O interface, wherein said control entity includes a second arbiter for processing said control signals to select a data packet to transmit to the CPU among the plurality of data packets suitable for transmission to the CPU.

175) A router, comprising:

- a) a routing layer, said routing layer including a plurality of I/O ports for exchanging data with components external to said router;
- b) a switching layer to switch data packets between I/O ports of said routing layer, said switching layer including an array of cells in communication with said routing layer for permitting exchange of data packets between said array of cells and said routing layer;
- c) each cell including a memory for receiving a data packet from said routing layer;
- d) said routing layer including a controller to control release of a data packet toward a cell of said array at least in part on a basis of a degree of occupancy of the memory in said cell.

176) A router as defined in claim 175, wherein said routing layer comprising a memory for storing data packets for release to said switching layer, said controller controlling release of data packets from the memory of said routing layer.

177) A router as defined in claim 176, wherein the memory of said routing layer includes an area for storing data indicative of a degree of occupancy of the memory of said cell.

5 178) A router as defined in claim 177, wherein said controller is in communication with said memory to obtain access to the data indicative of a degree of occupancy of the memory of said cell, said controller controlling release of data packets from the memory of said routing layer at least in part on a basis of the data indicative of a degree of occupancy of the memory of
10 said cell.

179) A router as defined in claim 178, wherein the memory of said routing layer includes a plurality of areas associated with respective cells of said array, each area operative to store data indicative of a degree of occupancy of the memory
15 of a corresponding cell.

180) A router as defined in claim 179, wherein said controller is responsive to a control signal issued by said switching layer to alter the data indicative of a degree of occupancy of the memory of a given cell in the area associated with
20 the given cell.

181) A router as defined in claim 180, wherein each cell of said switching layer is operative to issue a control signal to said controller to convey to said controller data indicative of the degree of occupancy of the memory of the cell.
25

182) A router as defined in claim 181, wherein the memory of each cell is partitioned into slots, each slot capable of storing a data packet.

183) A router as defined in claim 182, wherein each area associated with a given cell of said array is partitioned into zones, each zone being associated
30 with a slot of the memory of the given cell, each zone containing data indicating if the associated slot of the memory of the given cell is available for reception of a data packet.

- 184) A router as defined in claim 183, wherein each cell of said array, in response to release of a data packet from a certain slot of the memory of the cell, issues the control signal to convey to said controller data indicative of the degree of occupancy of the memory of the cell.
- 185) A router as defined in claim 184, wherein the control signal contains information identifying the certain slot of the memory of the cell.
- 186) A router as defined in claim 185, wherein said controller is responsive to the control signal containing information identifying the certain slot of the memory of the cell to alter the data in the zone of the memory of the routing layer associated with the certain slot.
- 187) A switch fabric implemented on a chip, comprising:
- a) an array of cells;
 - b) an I/O interface in communication with said array of cells for permitting exchange of data packets between said array of cells and components external to said array of cells;
 - c) each cell communicating with at least one other cell of said array permitting exchange of data packets between the cells of said array;
 - d) each cell including:
 - I) a memory for receiving a data packet from said I/O interface; and
 - II) a control signal path for transporting a control signal to a component external to said array of cells, the control signal being indicative of a degree of occupancy of said memory.
- 188) A switch fabric as defined in claim 187, wherein said memory is partitioned into slots, each slot capable of storing a data packet.
- 189) A switch fabric as defined in claim 188, wherein the control signal indicative of a degree of occupancy of said memory contains information indicating whether a slot of said memory is free to accept a data packet.

190) A switch fabric as defined in claim 189, wherein in response to release of a data packet from a certain cell of said memory, said cell generating the control signal, the control signal including information identifying the certain cell.

5

191) A router, comprising:

- a) a routing layer, said routing layer including a plurality of I/O ports for exchanging data with components external to said router; and
- b) a switching layer in communication with said routing layer to switch data packets between I/O ports of said routing layer;
- c) said routing layer including a controller, said controller responsive to reception of a control signal containing information indicating that said switching layer is capable of accepting a data packet, to release a data packet to said switching layer.

10

15

192) A router as defined in claim 191, wherein said switching layer includes a memory, the control signal containing information indicating the degree of occupancy of said memory.

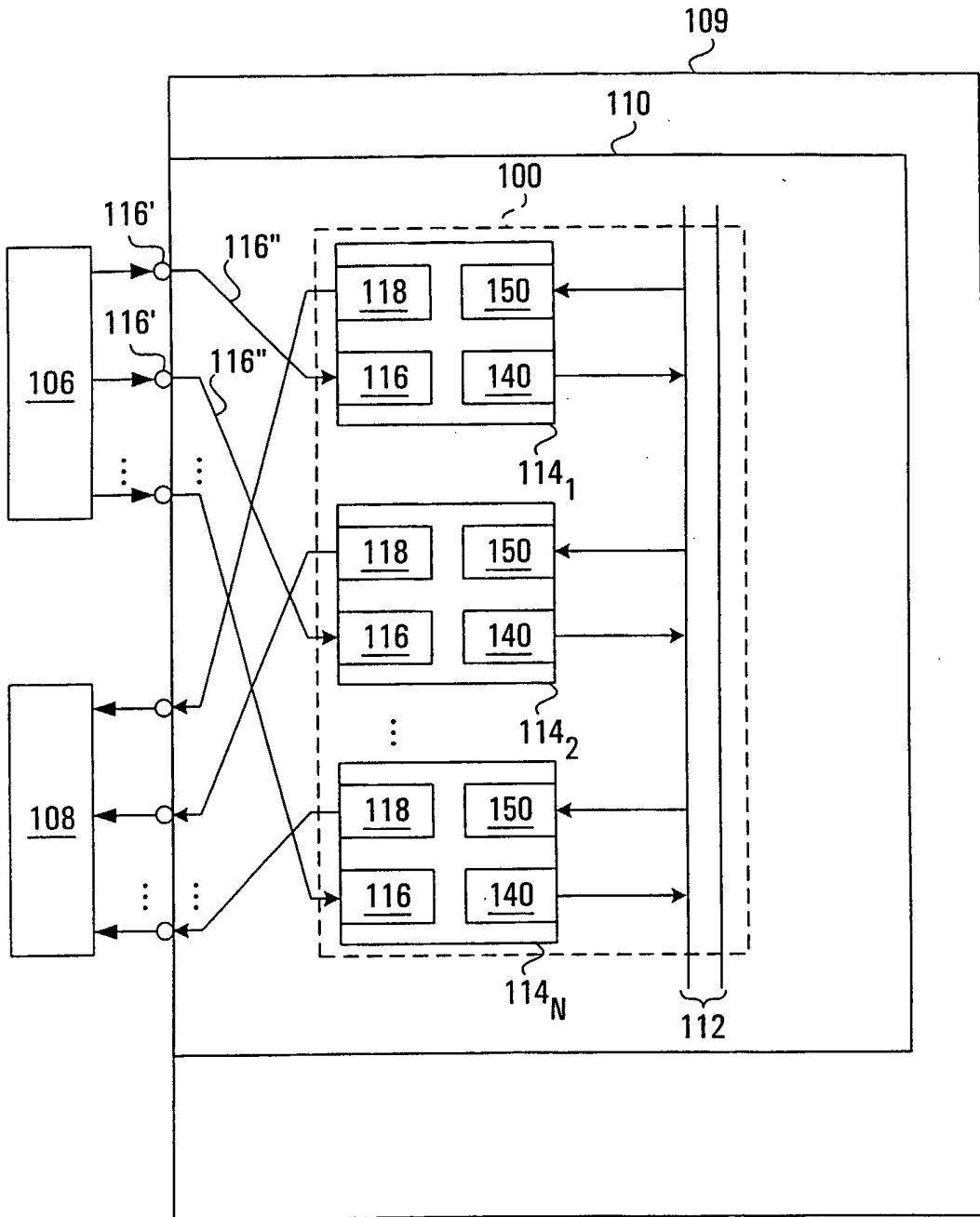

FIG. 1

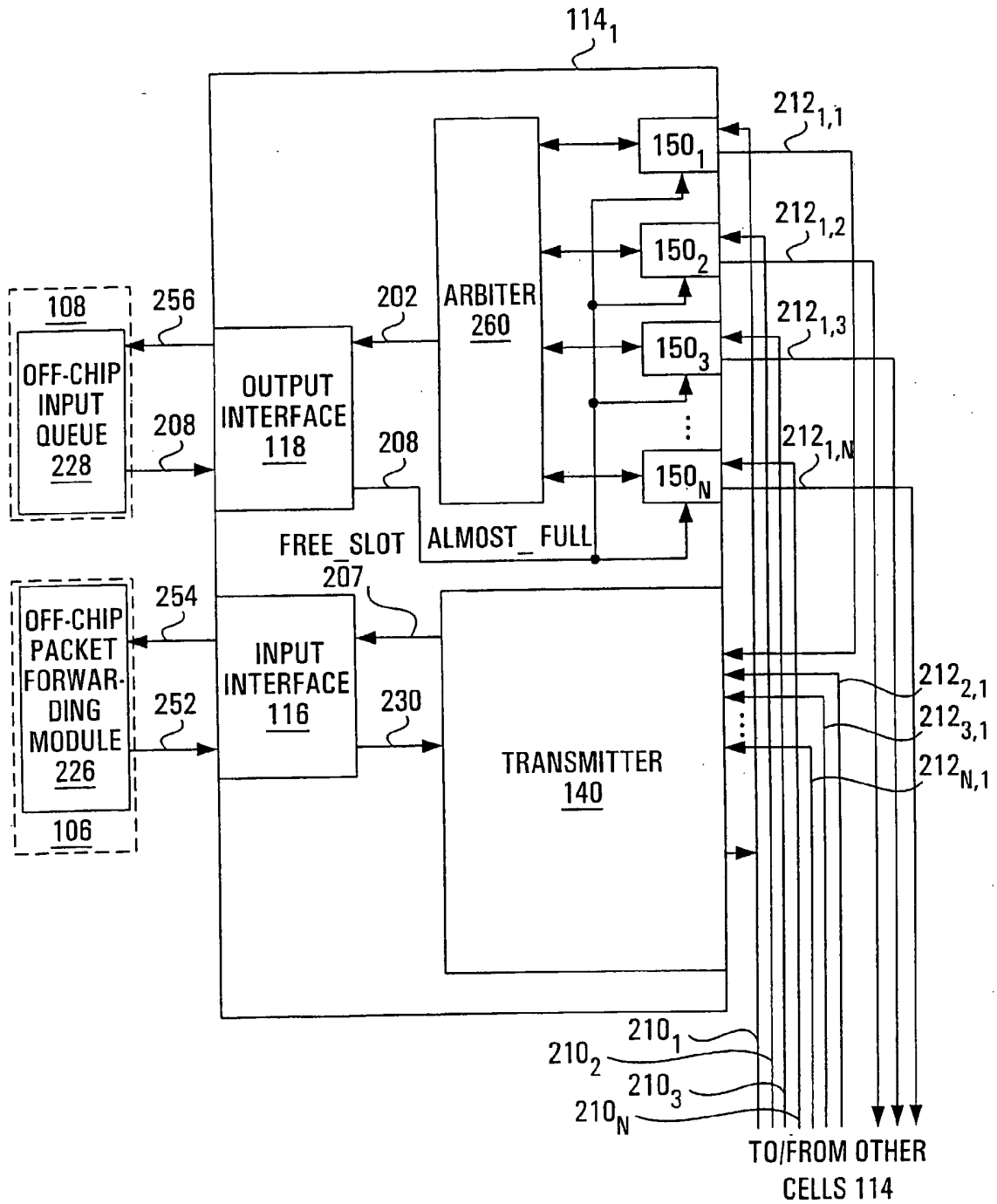

FIG. 2

3/21

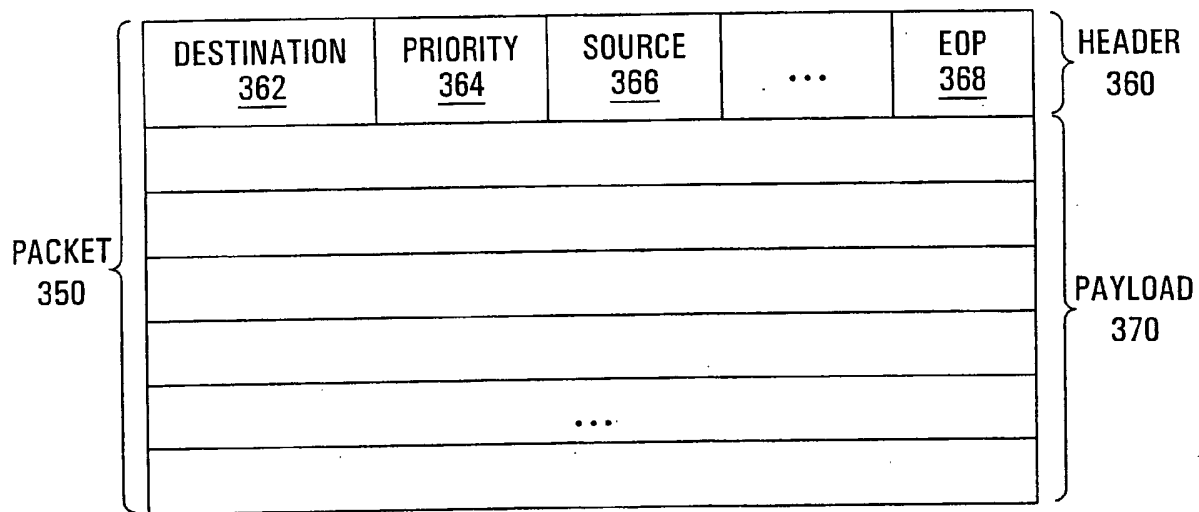

FIG. 3

4/21

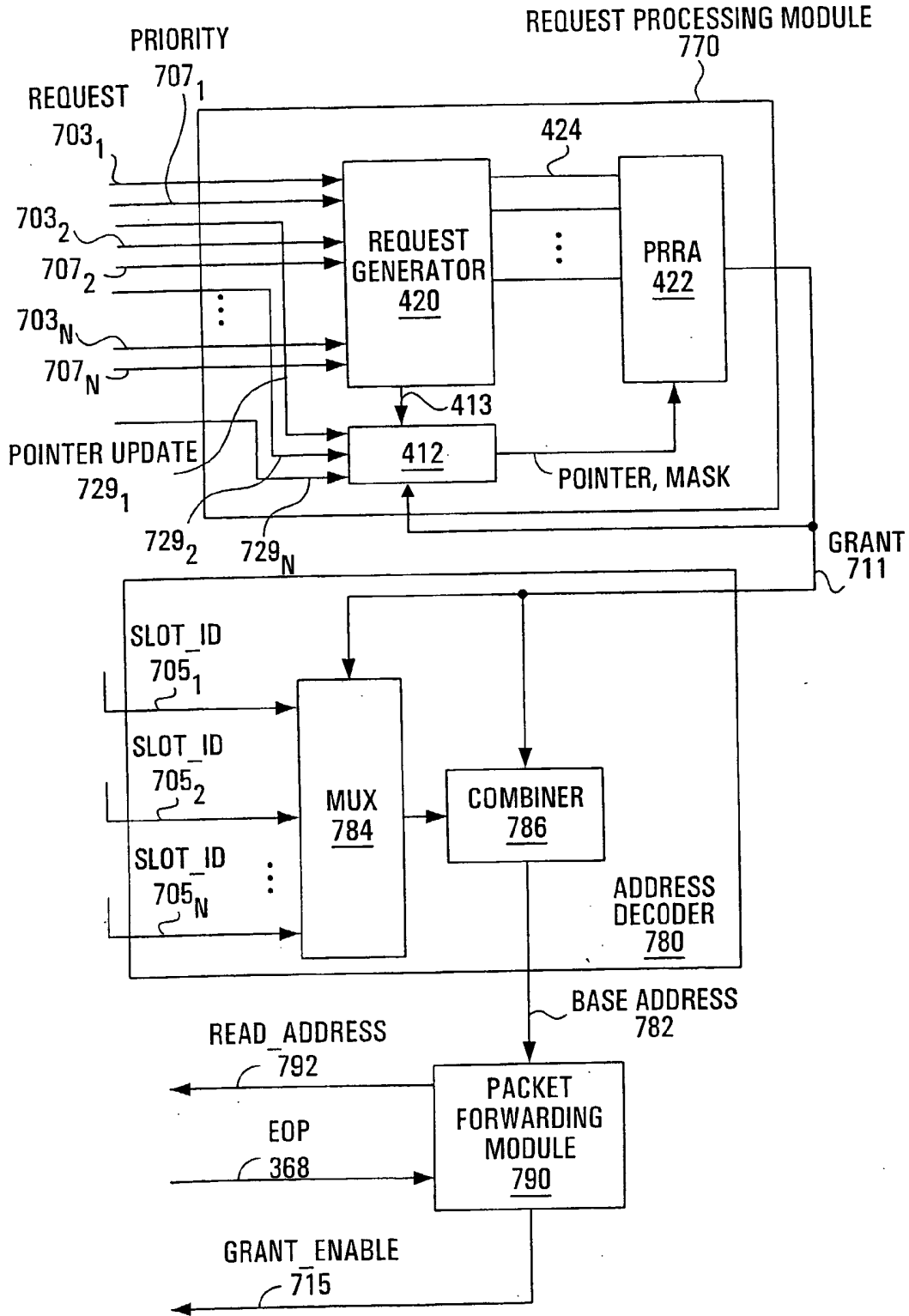

FIG. 4

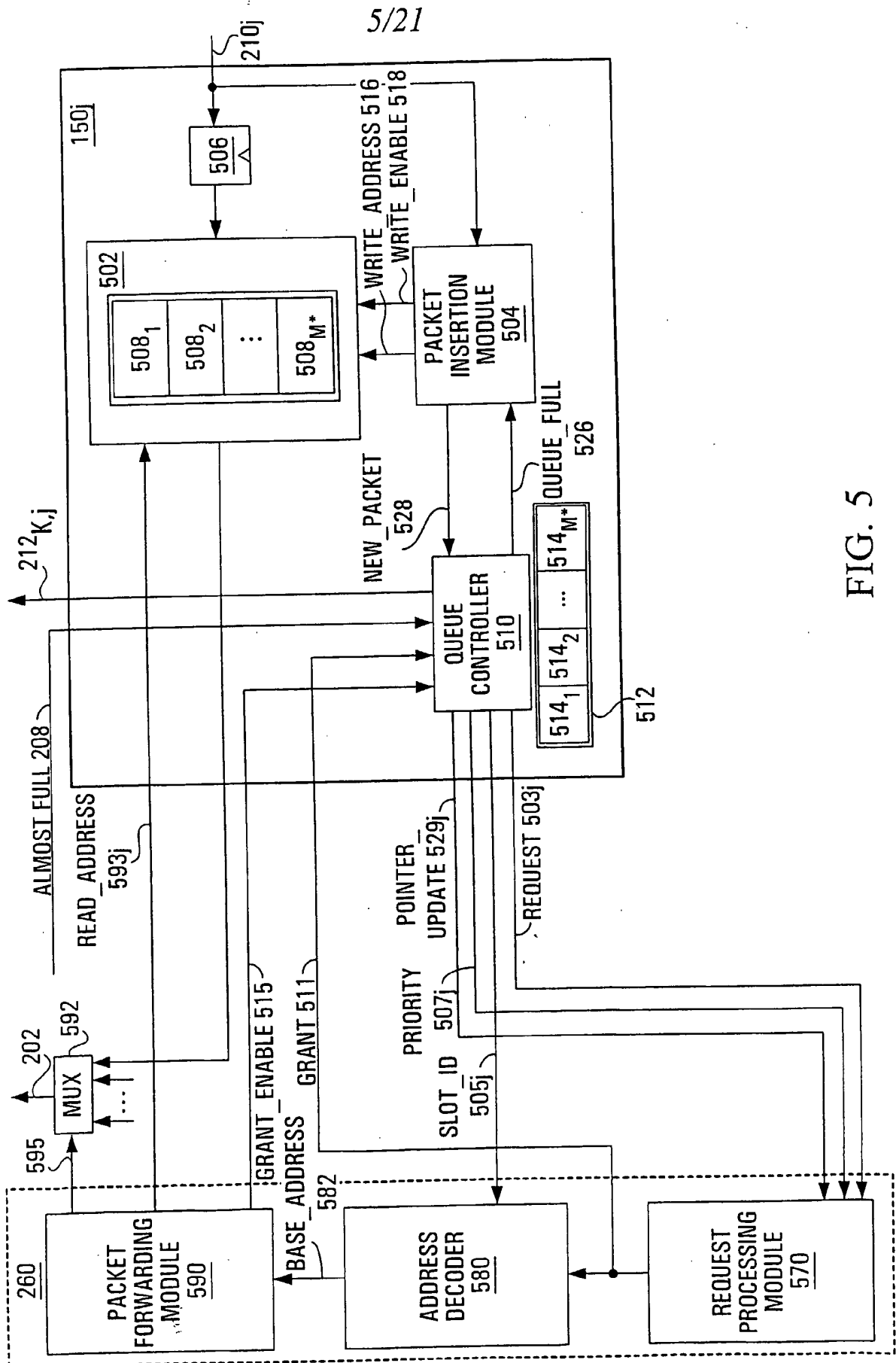

FIG. 5

6/21

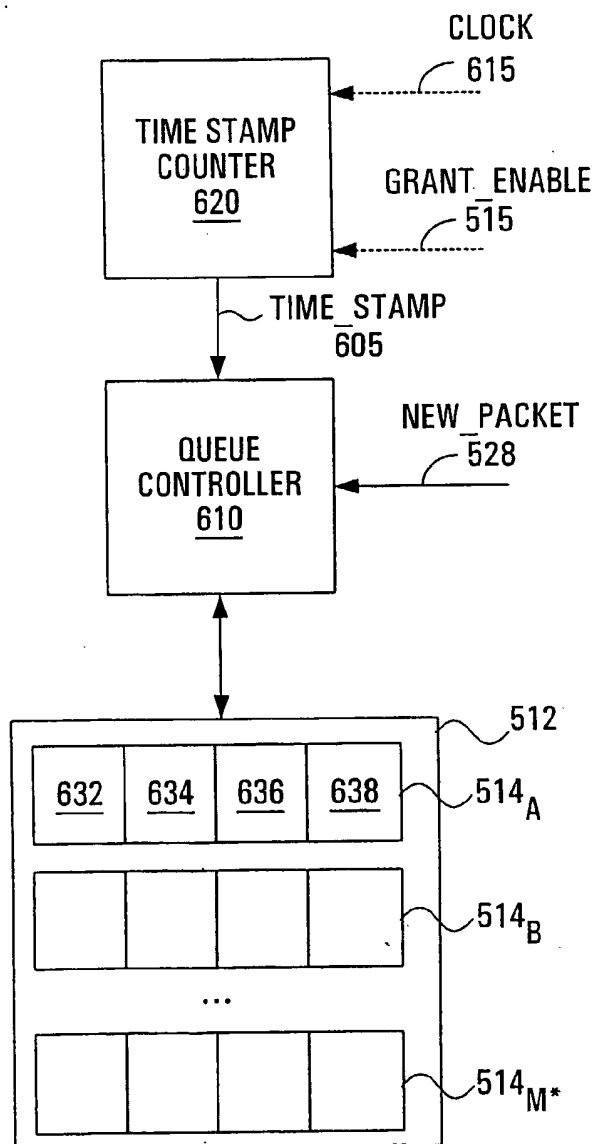

FIG. 6

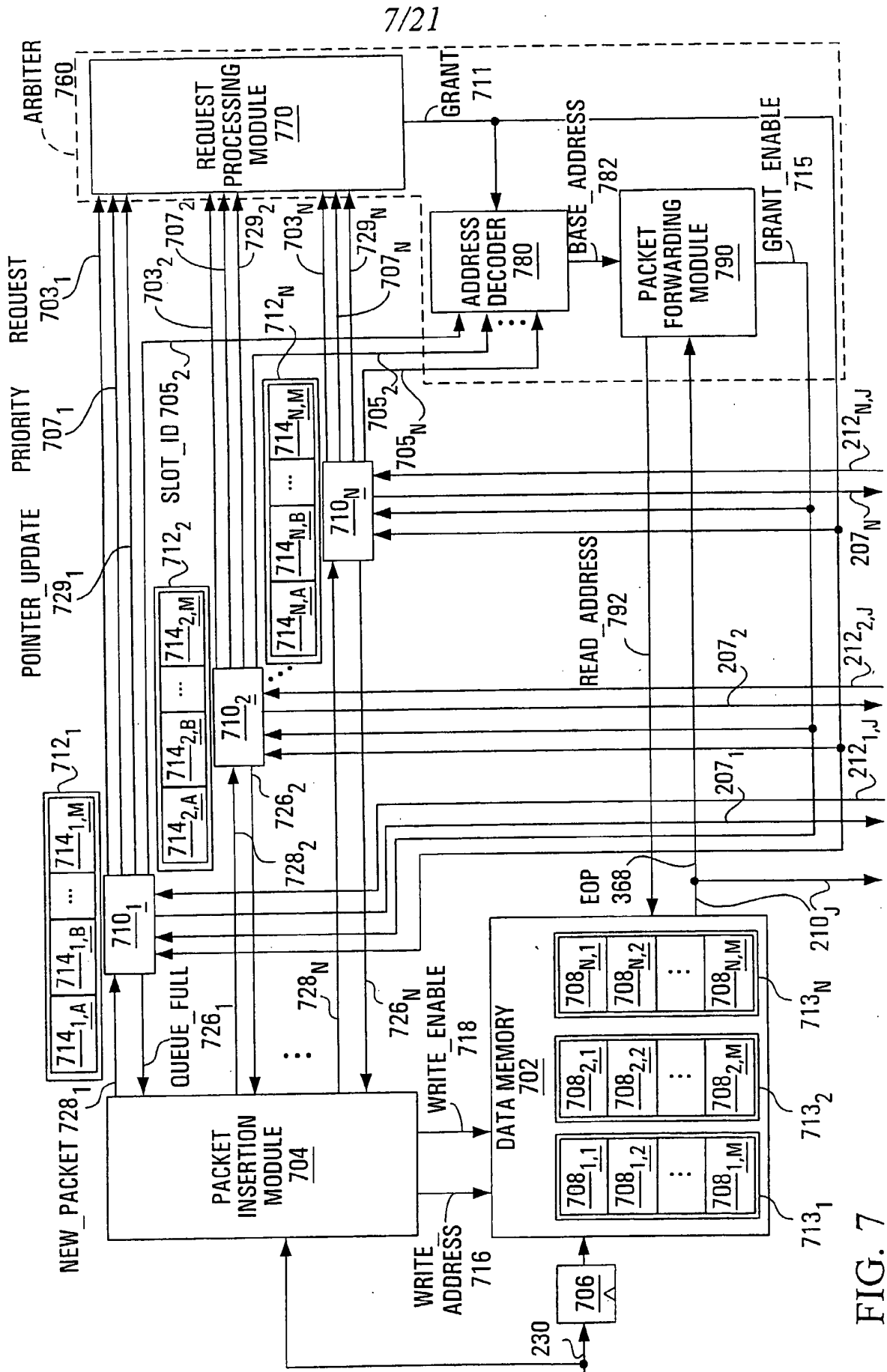

FIG. 7

8/21

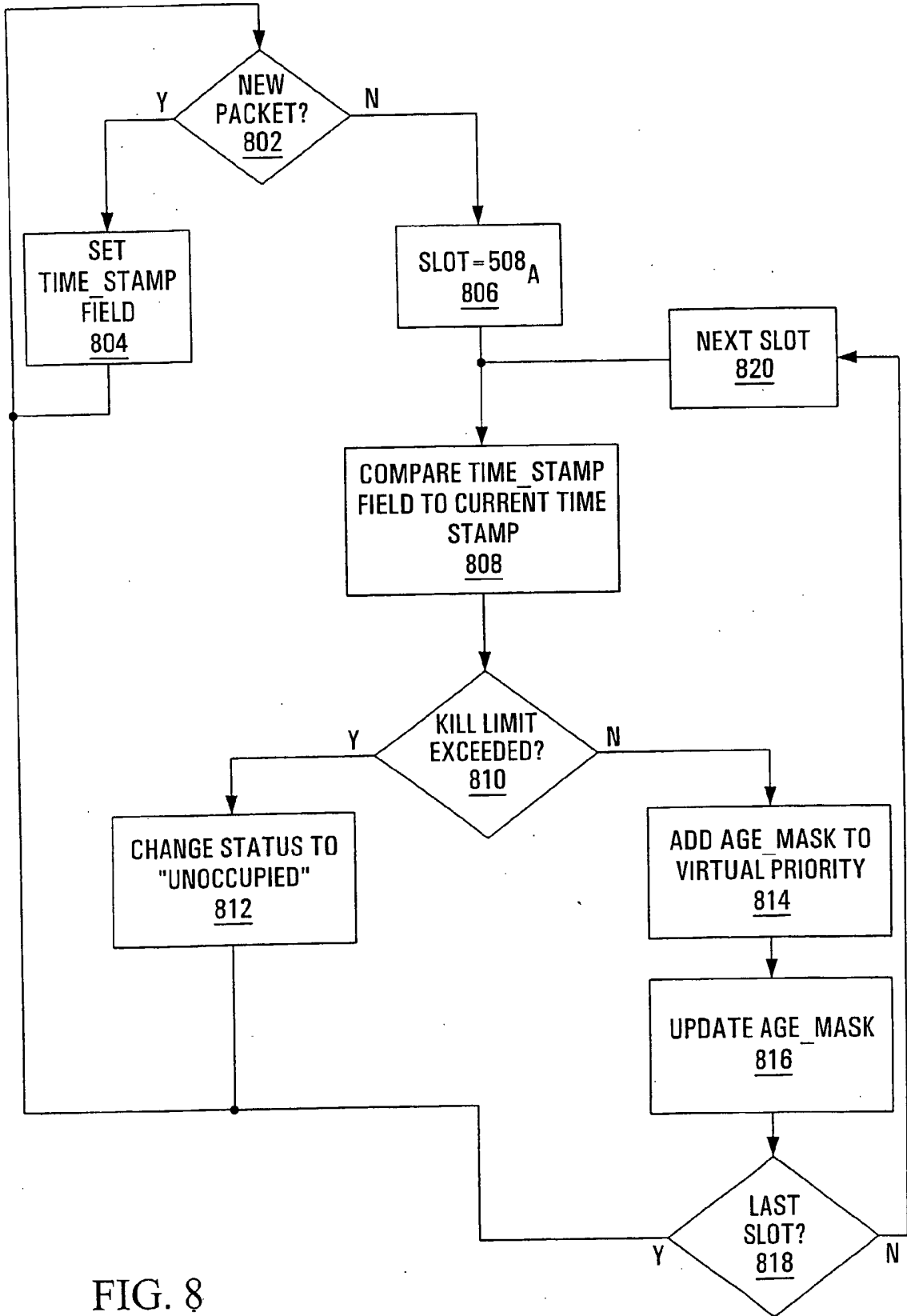

FIG. 8

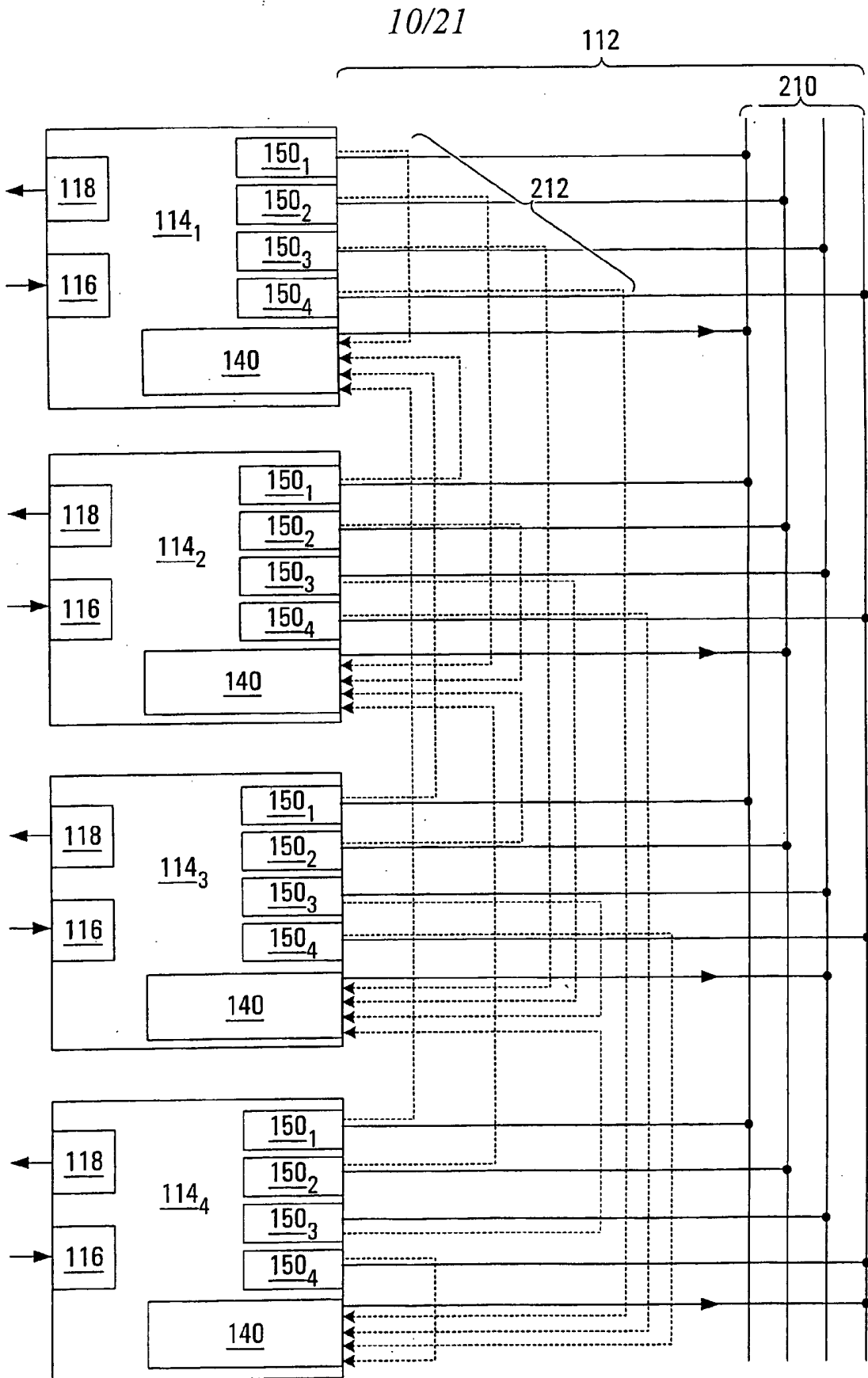

FIG. 10

11/21

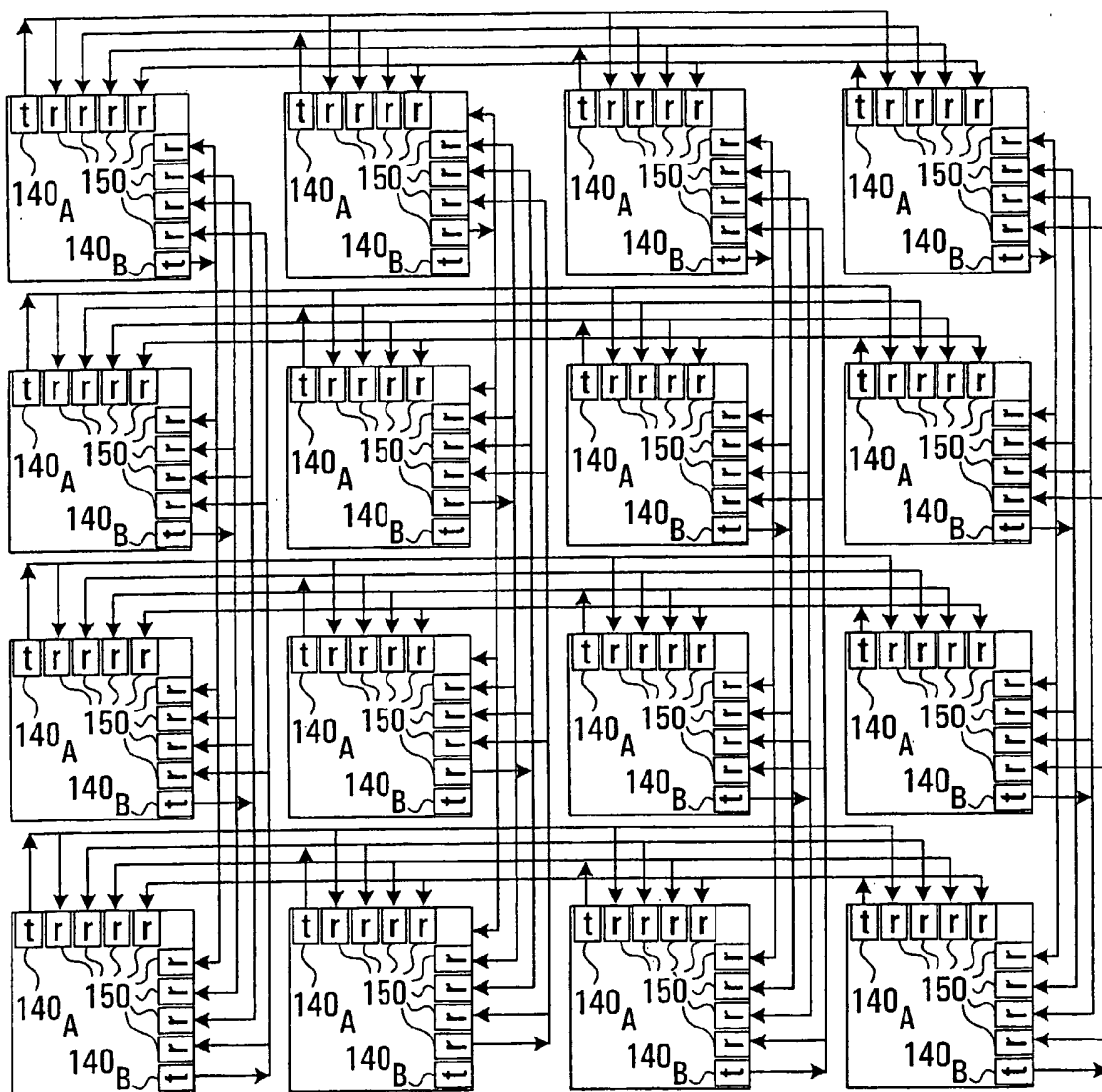

FIG. 11

12/21

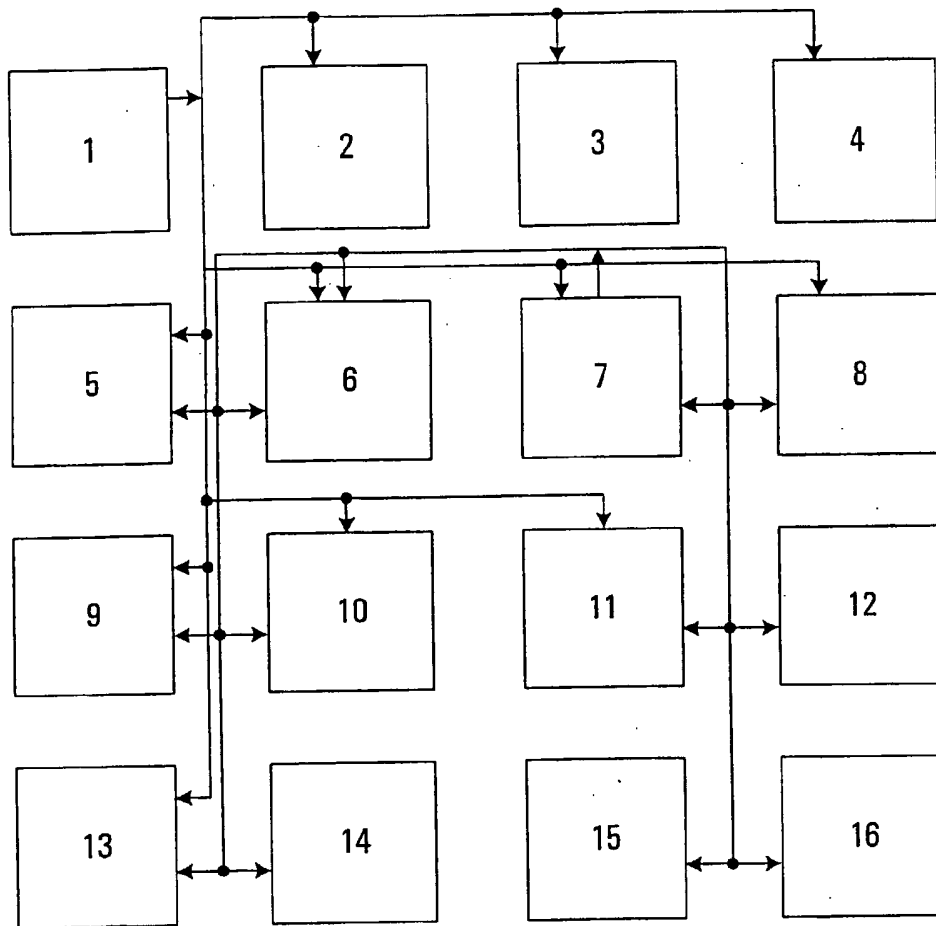

FIG. 12

13/21

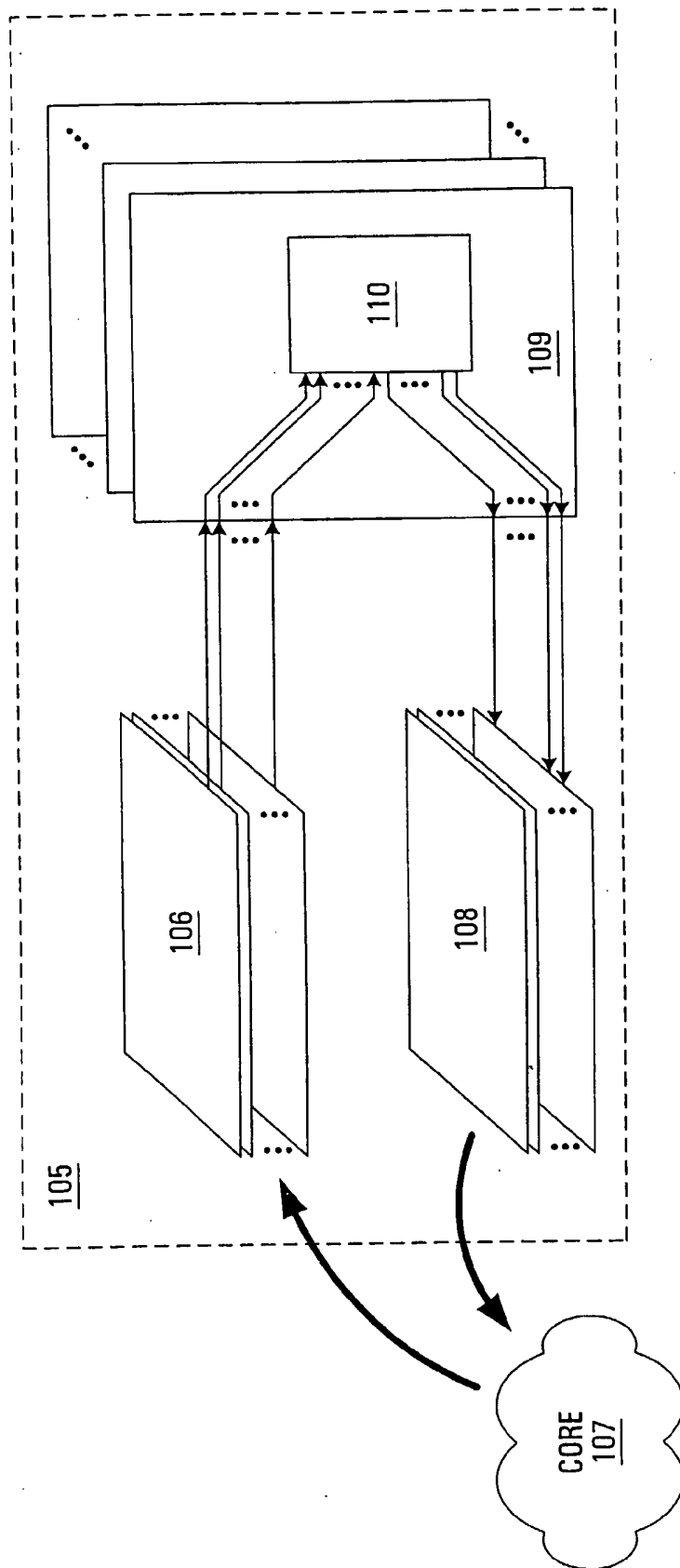

FIG. 13

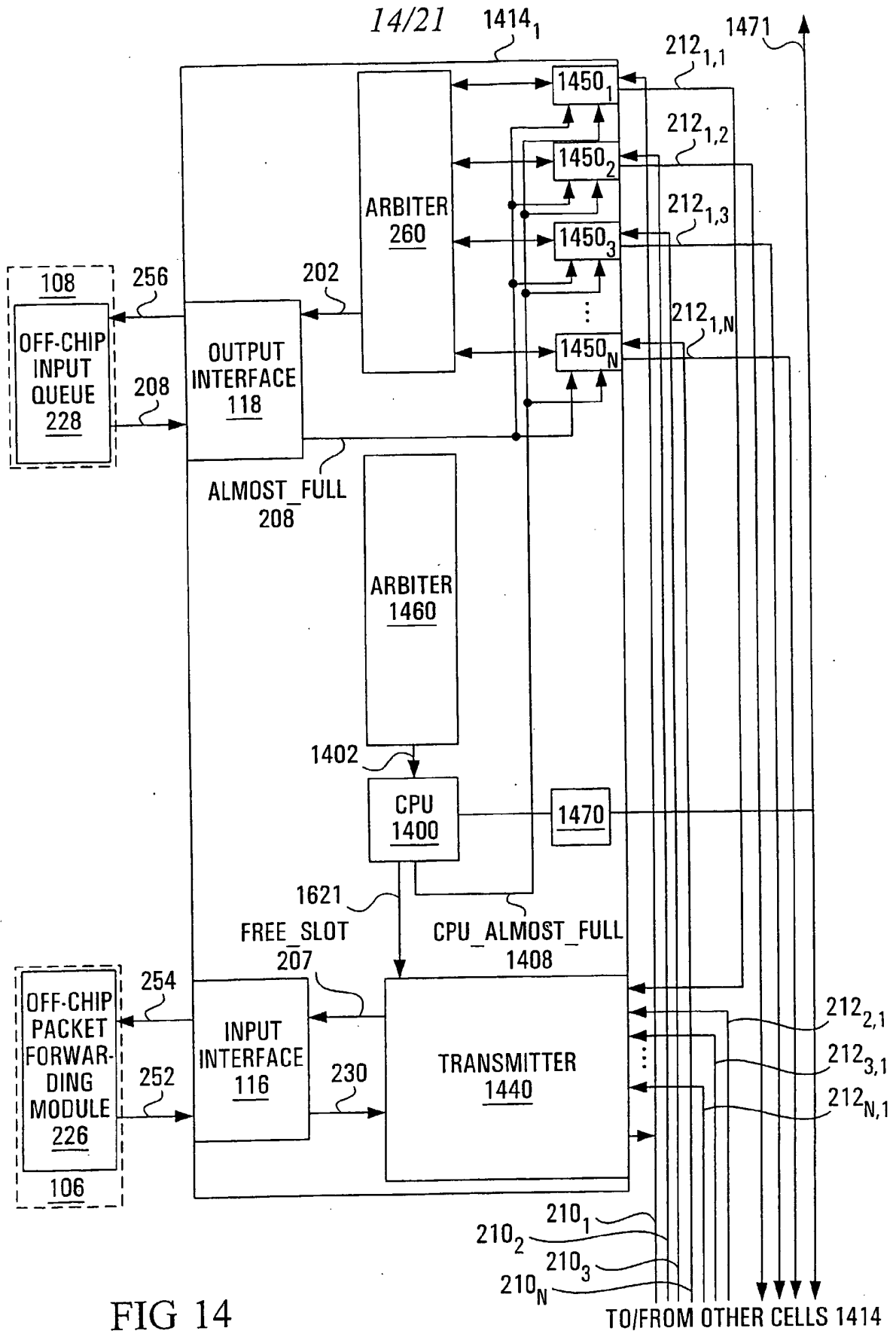

FIG 14

15/21

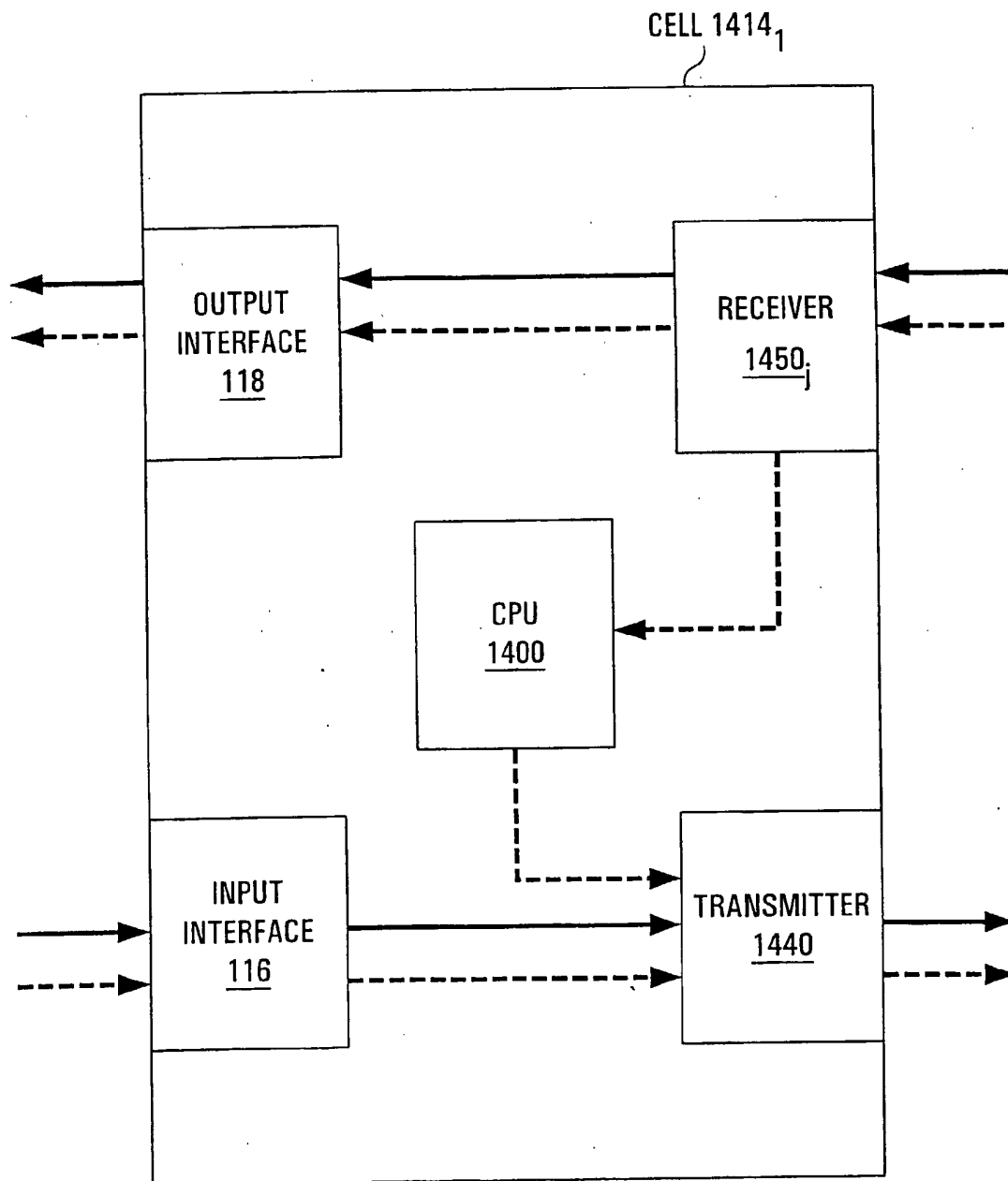

FIG. 15

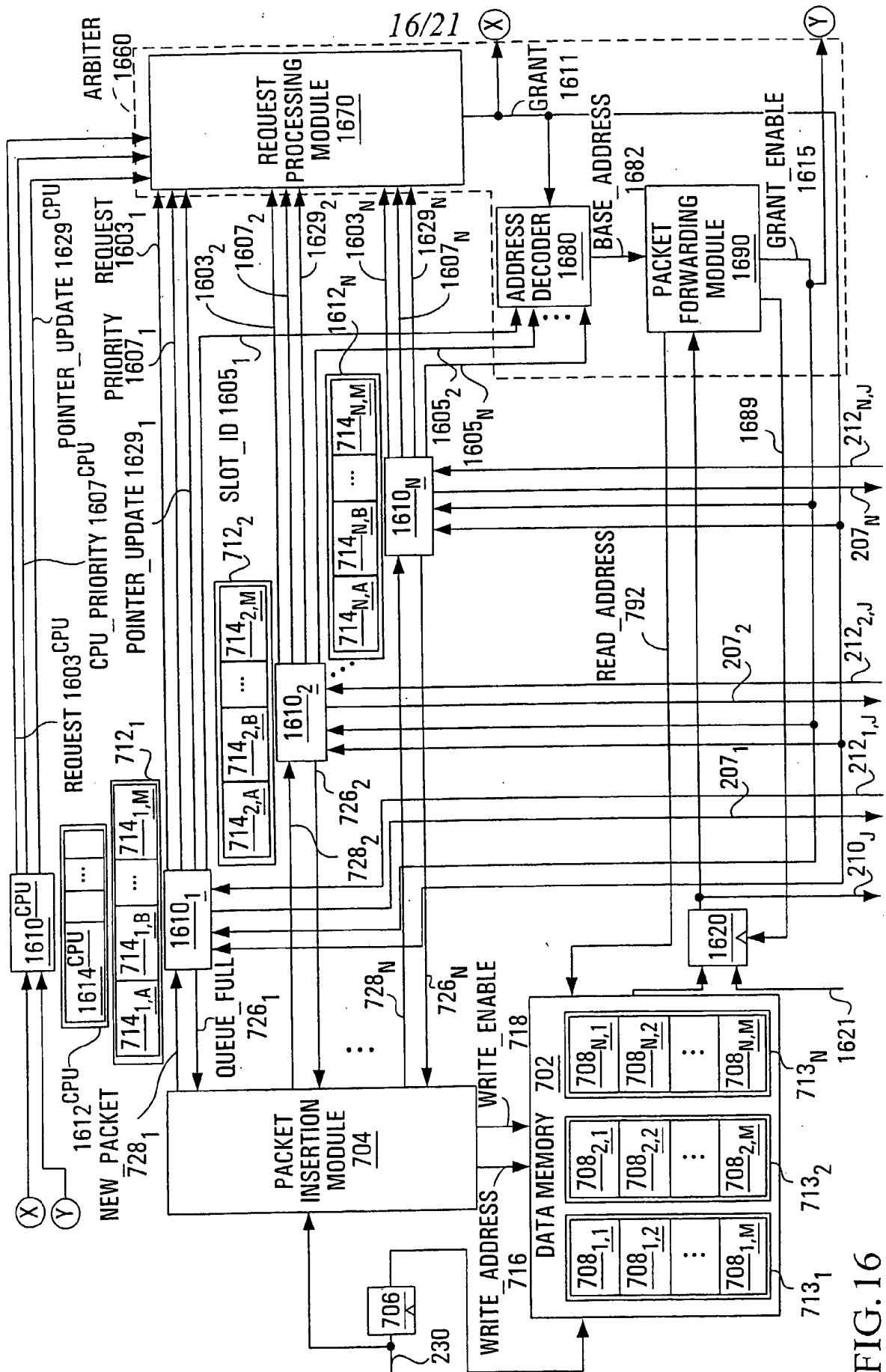

FIG. 16

FIG. 17A

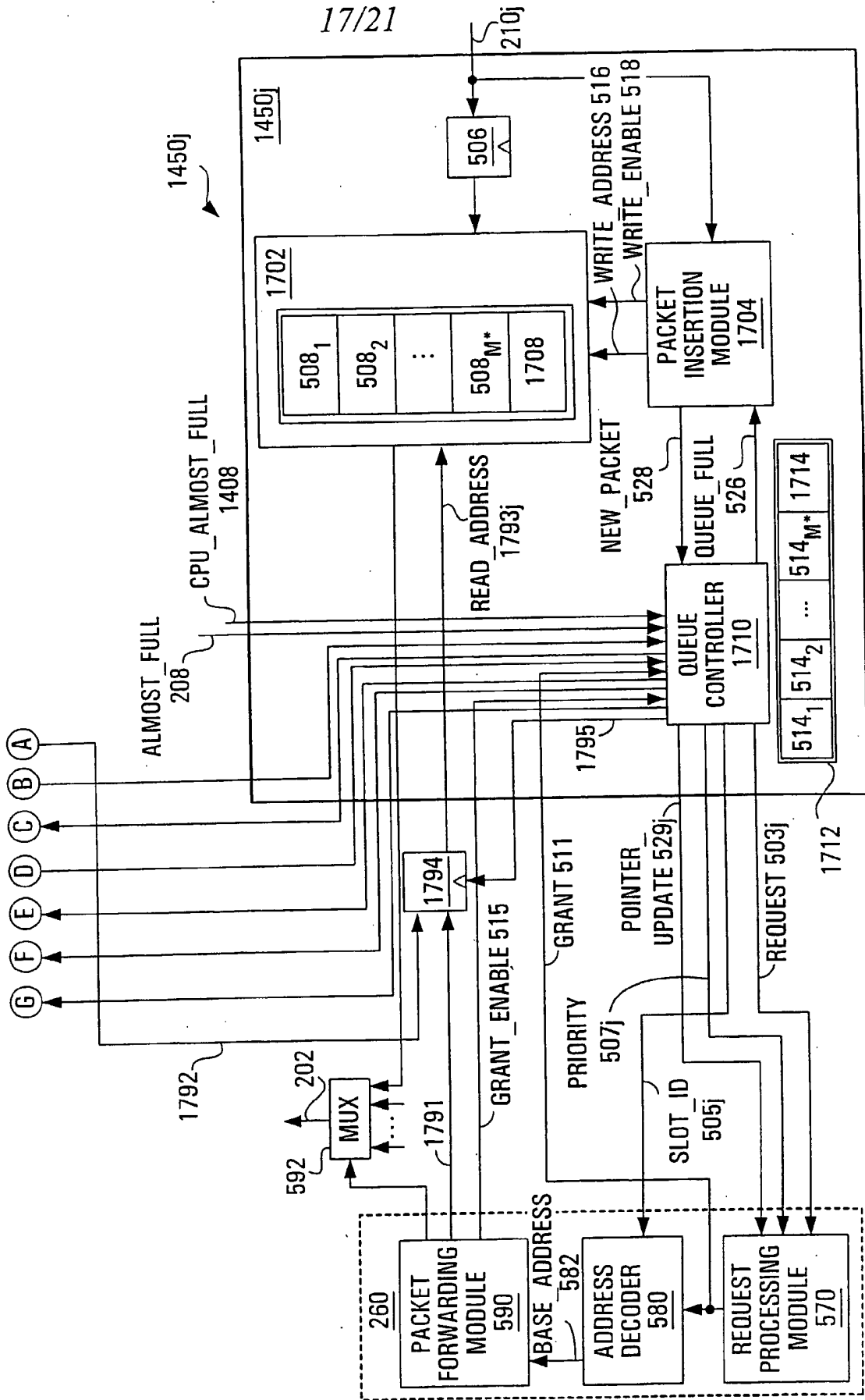
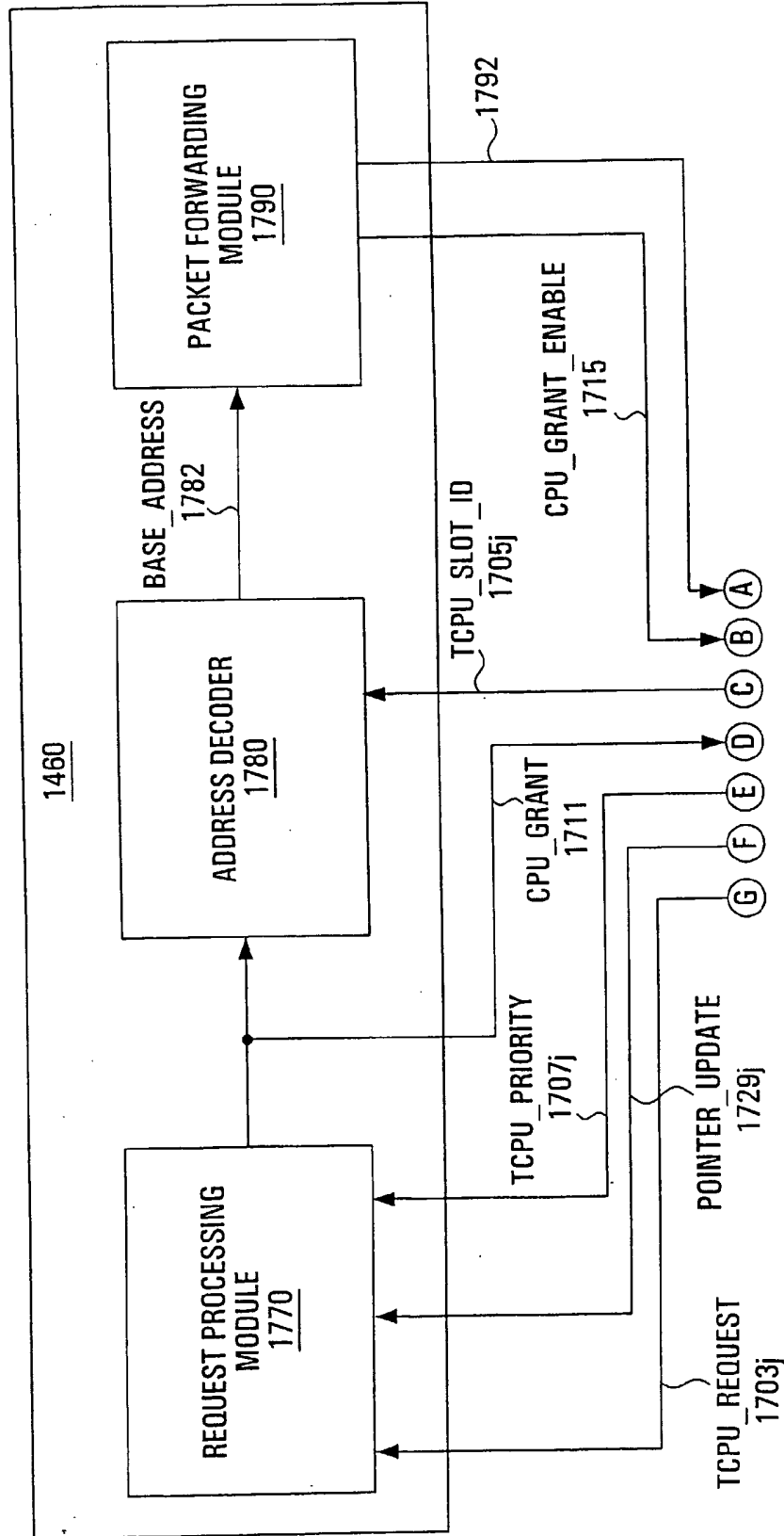

FIG. 17B



19/21

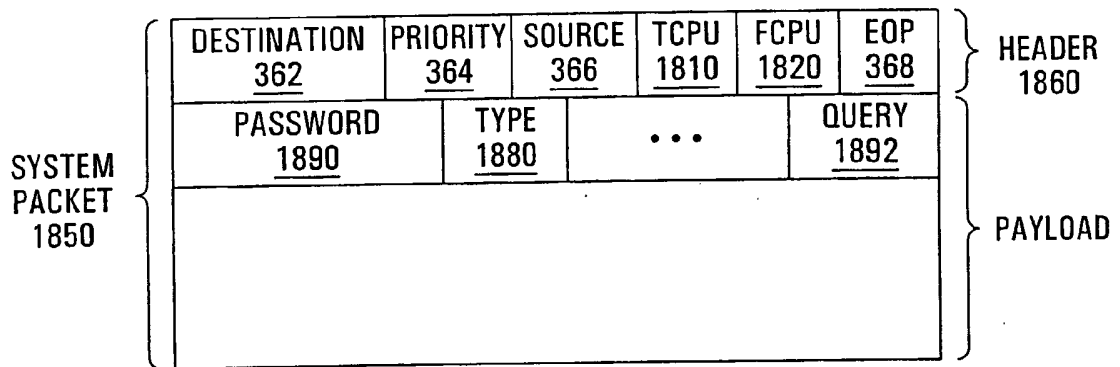

FIG. 18

20/21

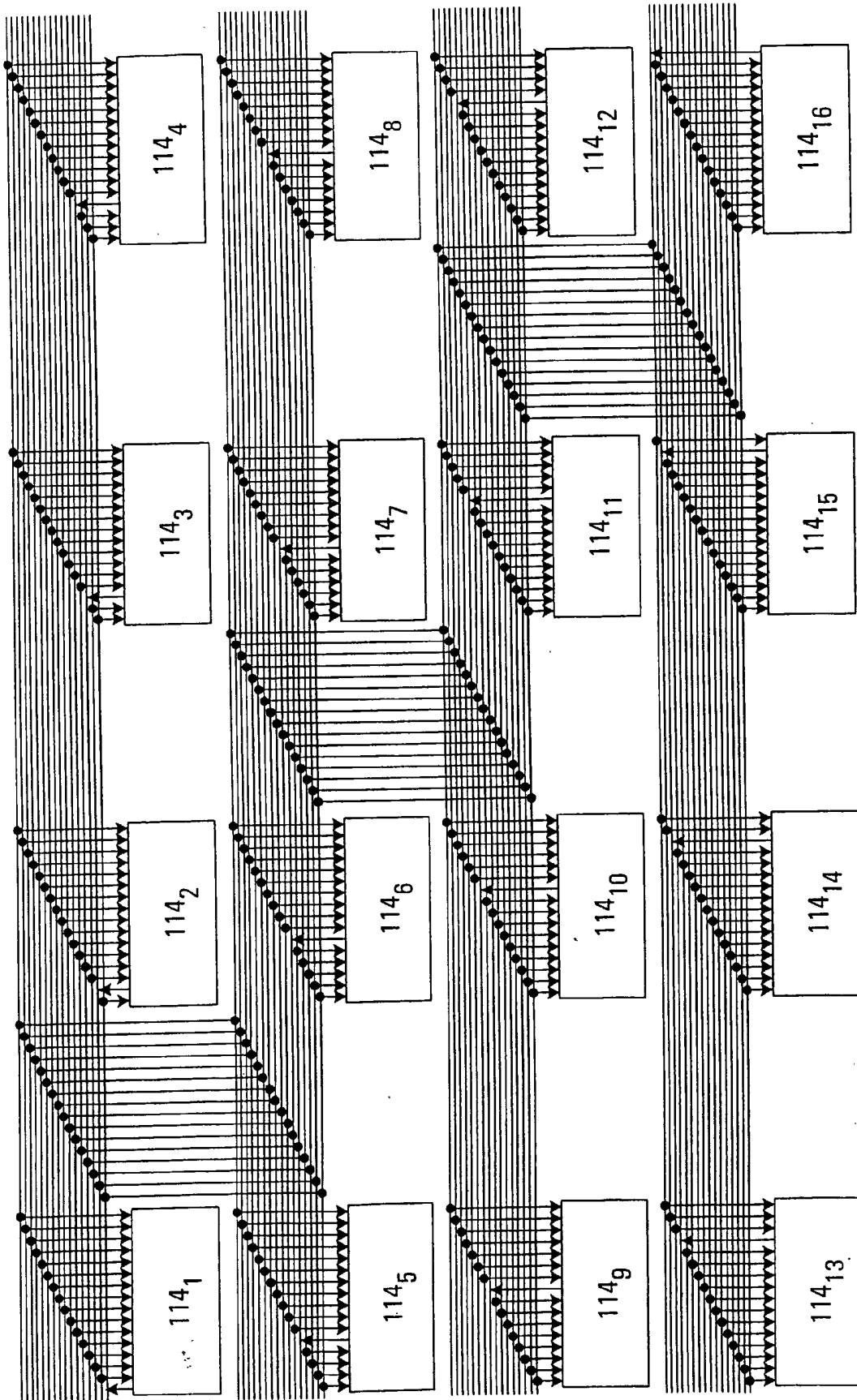

FIG. 19

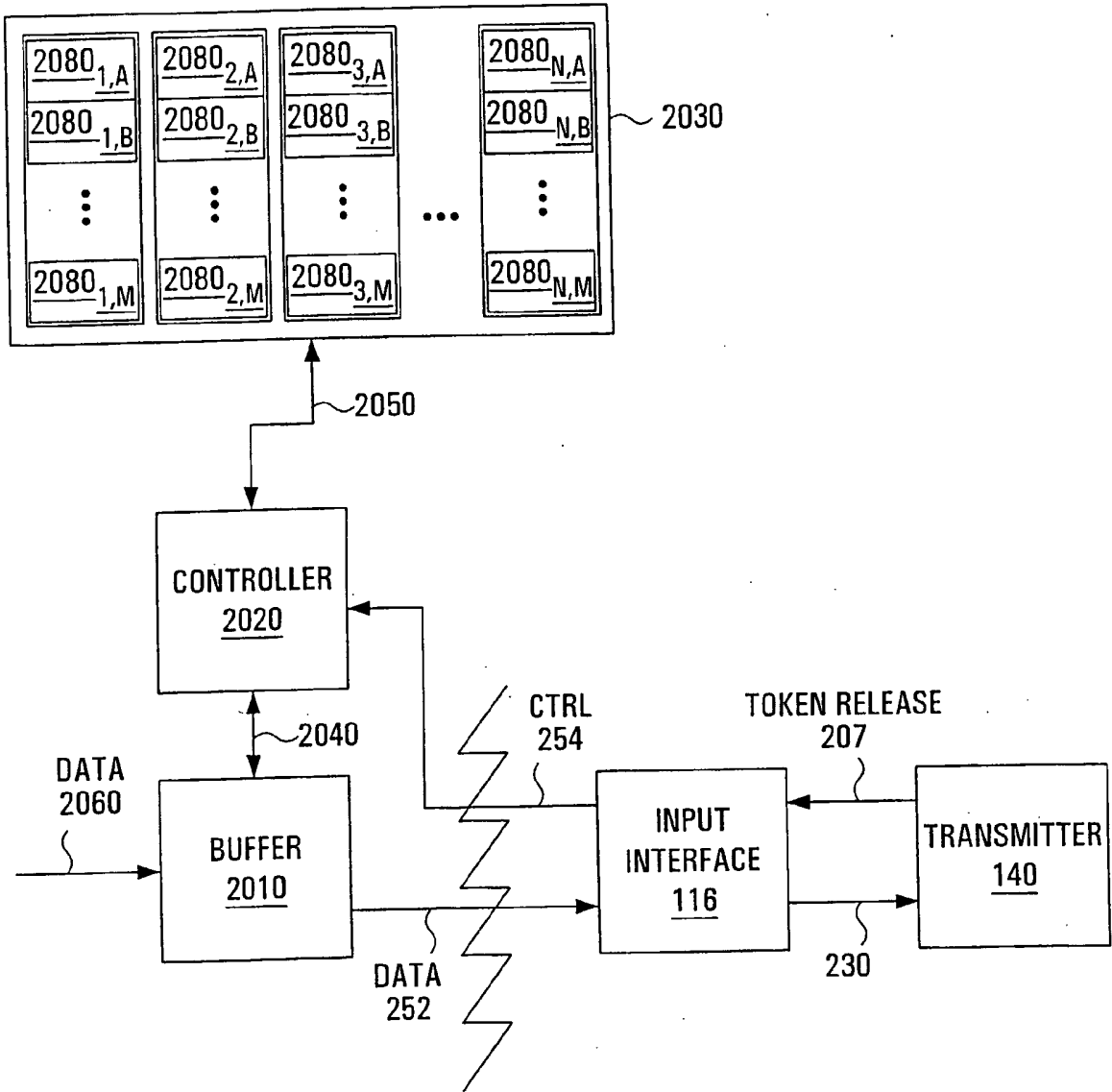

FIG. 20