



INTERNATIONAL APPLICATION PUBLISHED UNDER THE PATENT COOPERATION TREATY (PCT)

(51) International Patent Classification ⁶ : G09F	A2	(11) International Publication Number: WO 99/39319 (43) International Publication Date: 5 August 1999 (05.08.99)
(21) International Application Number: PCT/IL99/00061 (22) International Filing Date: 29 January 1999 (29.01.99) (30) Priority Data: 123123 29 January 1998 (29.01.98) IL (71) Applicant (for all designated States except US): LEDI-LITE LTD. [IL/IL]; Ofakim Technology Center, P.O. Box 633, 80300 Ofakim (IL). (71)(72) Applicants and Inventors: FILIPOVSKY, Menachem [IL/IL]; P.O. Box 633, 80300 Ofakim (IL). SAMUEL, Boaz [IL/IL]; P.O. Box 633, 80300 Ofakim (IL). SPERO, Yechezkel [IL/IL]; P.O. Box 633, 80300 Ofakim (IL). (74) Agent: FRIEDMAN, Mark, M.; Beit Samueloff, Haomanim Street 7, 67897 Tel Aviv (IL).		(81) Designated States: AL, AM, AT, AU, AZ, BA, BB, BG, BR, BY, CA, CH, CN, CU, CZ, DE, DK, EE, ES, FI, GB, GD, GE, GH, GM, HR, HU, ID, IL, IN, IS, JP, KE, KG, KP, KR, KZ, LC, LK, LR, LS, LT, LU, LV, MD, MG, MK, MN, MW, MX, NO, NZ, PL, PT, RO, RU, SD, SE, SG, SI, SK, SL, TJ, TM, TR, TT, UA, UG, US, UZ, VN, YU, ZW, ARIPO patent (GH, GM, KE, LS, MW, SD, SZ, UG, ZW), Eurasian patent (AM, AZ, BY, KG, KZ, MD, RU, TJ, TM), European patent (AT, BE, CH, CY, DE, DK, ES, FI, FR, GB, GR, IE, IT, LU, MC, NL, PT, SE), OAPI patent (BF, BJ, CF, CG, CI, CM, GA, GN, GW, ML, MR, NE, SN, TD, TG). Published <i>Without international search report and to be republished upon receipt of that report.</i>
(54) Title: ILLUMINATED SIGN SYSTEM		
(57) Abstract A sign system including a series-string connection of LED's, and a Zener diodeshunting a group of LED's in the series-string connection of LED's.		

FOR THE PURPOSES OF INFORMATION ONLY

Codes used to identify States party to the PCT on the front pages of pamphlets publishing international applications under the PCT.

AL	Albania	ES	Spain	LS	Lesotho	SI	Slovenia
AM	Armenia	FI	Finland	LT	Lithuania	SK	Slovakia
AT	Austria	FR	France	LU	Luxembourg	SN	Senegal
AU	Australia	GA	Gabon	LV	Latvia	SZ	Swaziland
AZ	Azerbaijan	GB	United Kingdom	MC	Monaco	TD	Chad
BA	Bosnia and Herzegovina	GE	Georgia	MD	Republic of Moldova	TG	Togo
BB	Barbados	GH	Ghana	MG	Madagascar	TJ	Tajikistan
BE	Belgium	GN	Guinea	MK	The former Yugoslav Republic of Macedonia	TM	Turkmenistan
BF	Burkina Faso	GR	Greece	ML	Mali	TR	Turkey
BG	Bulgaria	HU	Hungary	MN	Mongolia	TT	Trinidad and Tobago
BJ	Benin	IE	Ireland	MR	Mauritania	UA	Ukraine
BR	Brazil	IL	Israel	MW	Malawi	UG	Uganda
BY	Belarus	IS	Iceland	MX	Mexico	US	United States of America
CA	Canada	IT	Italy	NE	Niger	UZ	Uzbekistan
CF	Central African Republic	JP	Japan	NL	Netherlands	VN	Viet Nam
CG	Congo	KE	Kenya	NO	Norway	YU	Yugoslavia
CH	Switzerland	KG	Kyrgyzstan	NZ	New Zealand	ZW	Zimbabwe
CI	Côte d'Ivoire	KP	Democratic People's Republic of Korea	PL	Poland		
CM	Cameroon	KR	Republic of Korea	PT	Portugal		
CN	China	KZ	Kazakstan	RO	Romania		
CU	Cuba	LC	Saint Lucia	RU	Russian Federation		
CZ	Czech Republic	LI	Liechtenstein	SD	Sudan		
DE	Germany	LK	Sri Lanka	SE	Sweden		
DK	Denmark	LR	Liberia	SG	Singapore		
EE	Estonia						

ILLUMINATED SIGN SYSTEM

FIELD AND BACKGROUND OF THE INVENTION

The present invention relates to a general illuminated sign and signal technology having improved performance, i.e. high reliability but very low energy consumption and the advantages that are derived thereof. The signs and signals in this system are composed of discrete light sources, examples of which is the light emitting diodes (herein-after LED's) and miniature low-voltage filament lamps. The discrete light sources are used singly or are arranged in groupings to create patterns which are observed to constitute single letters, numerals, symbols, pictures or complete signs. Individual characters may be further arranged to generate complete signs. Signs may be composed of standard character elements in the field vs. typically in a sign shop, thus presenting a flexible method to compose illuminated signs of a fixed message.

The improvements in this invention derive from efficient energy use:

- a) light energy is only produced in the sign as is necessary for the observer to understand the message, i.e. only the message itself is lit vs. illuminating the complete sign surface including the background;
- b) light energy produced is aimed in the direction of the observer as much as is possible;
- c) the energy source is properly matched to the light source through improved electrical circuitry significantly reducing energy use; and,
- d) light energy is produced only when needed.

As a whole, or in part, these principles enable the illumination of a myriad of sign and signaling devices heretofore impractical to illuminate due to the high power consumption of present sign illuminating technology. The invention provides for a new generation of reliable, energy-efficient, signs which are more readable and applicable in a variety of sign situations including: house signs, street signs, advertising signs, exit signs, emergency signs, signs over business, display signs, traffic signs, traffic signals, roadway indicators, and in any application where an improvement in readability, reliability, and efficiency is desired in day-to-day use. The low power consumption makes feasible a battery back-up capability which allows address location and direction signs to remain operative in extended civil emergency situations, and a solar cell capability which allows for installation anywhere without need for an external power supply.

The inventive features disclosed herein are the result of the Applicant's service as an ambulance driver in the Gulf War but relates to all natural disasters such as earthquakes, hurricanes, fires, etc.. Applicant was required to locate street and house addresses in a city, where the electrical power was interrupted, so there were no street or traffic signs. Absence of signs in times of emergency may also result from the use of incandescent and fluorescent light sources, which utilize fragile glass envelopes which easily break due to the impact shock of bombs, or explosions of gas mains, during earthquakes and other natural disasters. These are the motivations for a sturdier, more reliable, low energy usage, address, direction, and traffic signal, sign system with power supply back-up. Hence, the preference for an efficient, concentrated, very long life expectancy, reliable, light source, such as LED's, and also the preference for readability in daylight without electrical power. It should be appreciated that in emergency situations, the ability to locate an injured person rapidly is important to the patient's survival. No doubt emergency medical personnel anywhere would appreciate the significance of this reliability improvement.

PRIOR ART

Four major types of illuminated sign technologies are presently in use:

- 1) Surface-painted signs which are illuminated by external light sources, such as floodlights, which are generally located at acute angles to the sign. Light energy is wasted since, a) the entire sign surface is illuminated (not just the message), and b) a great percentage of the light reflected never reaches the observer either being spilled off to the sky or ground.
- 2) Light box signs where a light source is placed behind a translucent surface with the message spelled out on the translucent surface, in characters contrasting to the translucent surface background. Light energy is produced to provide equal luminous exitance over the entire face of the sign, including the background, as opposed to lighting only the character which has to be seen. Only a small fraction of the light produced reaches the eye of the observer on the ground, as the light exits the sign in all directions including upwards, thus wasting energy.
- 3) Signs comprising light sources which themselves spell out the sign message. Neon signs and exposed incandescent filament lamp signs, are examples of this technology. When not lit, these signs are not readily visible (unless a paint is

applied under the character or symbol) and are thus totally dependent on being illuminated to deliver the message. These signs are costly to make, operate and maintain as they are custom made for the client, of limited life span, fragile and the incandescent version is energy wasteful.

- 5 4) An improved light source sign is the LED matrix sign. LED technology is taken advantage of to create changing-message signs. These dynamic message signs are computer-controlled and provide interesting and attention-grabbing signs which are an excellent solution to illuminated signs with the need for a changing message. However, most signs are of a fixed message, and these signs are initially expensive and costly to operate. Expensive power-supply units are required, as each
10 addressable LED requires a separate current-balancing resistor, so energy consumption is high. These signs are relatively expensive since the complete sign area is covered with LED's. Since the LED's are located in a matrix, the LED's are indiscernible from their neighbors when not excited by an electrical power source.
- 15 Thus the sign must also be powered during the day.

For the purpose of comparison, we address the most similar prior art solution, which is a matrix of lamps, such as miniature incandescent lamps or light-emitting diodes (LED's), with each character in the "sign" consisting of a pattern of selected lamp elements in the matrix array. The pattern may be selected by computer, for example, in a store display
20 application, or in a highway sign.

The problems with the prior art are:

- 1) The problem of visibility of the sign in the daytime. In bright sunlight. In a matrix the lamp brightness must be greater than the ambient intensity, or the illuminated LED will become invisible among the rest of the LED's in the matrix.
- 25 2) Since many signs are of a fixed message, using a selected few LED's out of a matrix to spell out a street sign or house address, the sign is more costly and complicated than need be.
- 3) The reliability of the sign is less since it relies on logic circuitry and a complex power supply to drive the LED matrix introducing more elements besides LED's
30 which may cause failure..
- 4) The energy-use efficiency of the matrix sign is not as good as for a fixed sign. There are many problems with the use of parallel-connected LED's, such as in a

matrix sign or in prior art LED signs, which make parallel-connected LED's a poor design choice for a fixed or semi-fixed message sign application.

5) If the LED's are to be powered from a voltage source, with the current in each LED individually set, then a separate resistor is needed for each LED. This is extremely wasteful of electrical power.

6) In general, each color LED is a different semiconductor material, or a different "alloy", having its own, unique forward voltage drop, for a given light output at a given forward current. For example, red LED's typically have a forward drop at about 10mA of about 1.7V, while green LED's typically have a forward drop at about 10mA of about 2.2V. Since LED's are a semiconductor diode, it is necessary to reach the conduction "knee" of the diode curve, before the LED will conduct, and emit light. Thus, if one parallel connects a red and a green LED, he expects the red LED to light, and regulate the voltage across the two LED's at 1.7V, thereby resulting in the green LED not conducting at all. So parallel connection of LED's of different colors, in general, is a problem, requiring a separate series resistor for each LED, to balance the LED currents.

7) If many LED's of one color are to be connected in parallel, all of the parallel-connected LED's must have closely matched I-V characteristics. Again this is due to the fact that LED's are diodes, and the "current-sharing" between the parallel-connected diodes is very strongly dependent on the difference between the forward voltages of the diodes measured at a given reference current. For poorly-matched diodes, very noticeable differences in intensity are expected. Thus, in production, it would be impossible to use LED's from different manufacturers, or from different production lots from one manufacturer, and one would expect to have difficulty also even with one production lot. Again, balancing resistors are required.

Various attempts have been made to provide signs using LED's. A patentability search has been conducted resulting in the following patents:

US 5,424,924 (filed 2 Mar 94) has characters made of LED's operating from low-voltage.

US 5,303,124 (filed 21 July 93) replaces a light bulb with a series string of LED's powered from a high-voltage (63Vnominal) rechargeable battery. Normally, AC line power is used, but when the line drops, the battery provides power to the LED string. Preferably,

when battery-powered, the LED's are blinking, with a conventional blinker circuit connected in series with the battery and LED's. This conventional blinker circuit turns ON the LED's in order to cause the LED's to blink. This differs from the present invention in that; (a) the LED's replace a light bulb, and are not providing a character representation, and (b) the
5 blinking circuit is different from the Applicant's light blinking circuit, which operates in parallel with the LED's, shunting current around the LED's, to cause the LED's to blink by turning OFF the LED's. Further, the blinking-off circuit of the present invention may be connected to bracket a group of LED's anywhere along the series-connected string of LED's and the blinking-off circuit of the present invention is powered by the current in the series
10 LED string, not requiring a separate power source for the operation of the blinking-off circuit.

US 5,019,438 (filed 16 Nov 89) has a design of LED's apparently operated from a low voltage battery.

US 4,855,723 (filed 29 April 88) provides an outdoor building sign for emergencies.
15 This has cards on which characters are formed from LED's in a seven-segment type arrangement, with one resistor for the string of diodes in each segment. Power is from a 22V nominal battery. Current to each segment, for initial brightness control, is adjusted by resistor selection. This sign has a blinking strobe light, not blinking LED's. Variable brightness intensity control is accomplished by varying the rate of an oscillator which is an
20 alternative to continuous DC drive to the LED's. LED's are visible when illuminated. This differs from the present invention where address is visible in daytime even when LED's are not operational and is for day to day use rather than specifically as an alarm. Cards may be slanted in viewing direction. This differs from the present approach of slanting LED's or customizing the light distribution pattern of the LED itself, as will be described below.

25 US 4,709,307 (filed June 86) has LED characters, battery and a control circuit which may blink the LED's.

US 4,173,035 (filed 1 Dec 77) has a flexible strip with LED's mounted on it. By selectively energizing the LED's the effect of a moving display can be simulated. This does not form characters. A timer controlling the rate of blinking, controls the rate of apparent
30 motion. This is not a sign, but rather a moving spot.

US 4,384,317 (filed 17 May 83) has a "light-emitting device" consisting of a series string of LED's, forming a dedicated sign, a storage battery, and a photovoltaic array, typically providing 12V, providing operation either from the battery or the photovoltaic

(solar) array. The voltage required by the LED string is approximately the battery voltage. Control circuitry provides the option of blinking the sign. The assumption here is that the sign illumination cannot be seen in the daytime. This is unlike the sign of the present invention, in which the characters of the sign are visible and readable in daylight without electrical power applied.

US 4,951,405 (filed 28 Aug 90) provides fiber-optic-illuminated cutout characters mounted rails which transmit either electric power or light, as a modular sign system. If the rails carry electricity, then the characters have, e.g., incandescent bulbs for illumination; if optical energy is transmitted, the characters have, e.g., optical fibers for illumination. This also has an assumption of non-visibility of the illumination in the daytime.

US 4,854,062 (filed 25 Jan 88) provides a modular series-string-LED house-number sign system, transformer powered from the doorbell transformer! The characters are connected in parallel with each other and in parallel with the doorbell switch. Each character preferably has eight LED's in series.

US 4,667,277 (filed 20 Sept 85) is an dovetail-interlocking modular lamp housing.

US 4,532,579 (filed 13 April 84) provides modules which he assembled in various mechanical configurations, with one lamp illuminating each module. Again, we have the assumption that the illumination is not visible in the daytime.

US 4,471,415 (filed 20 June 83) provides a mounting bar for holding LED's on a printed-circuit board.

US 5,450,301 (filed 5 Oct 93) provides LED-array replacements for incandescent lamp display panels. This uses series strings of LED's. Optionally, red and green LED's in a ratio of one red LED to two green LED's, closely packed, give the appearance at a distance of amber color. A triac controller operates from the AC line to provide brightness control.

US 5,479,325 (filed 26 Dec 95) provides an electroluminescent strip to illuminate a pattern. The circuitry includes a battery, a DC/AC inverter, and "function stage", to provide visual effects, including flashing.

US 4,271,408 (filed 12 Oct 79) provides a concave-mirror-cell surface with LED's in the concave mirrors. This is designed for visibility 24-hrs, e.g., for traffic signals! He says 62 LED's may be series-connected for about 100V driving voltage, and units of this may be parallel-connected.

Further, Applicant has discovered US 5,020,253 (filed 6 February 90), which provides a modular assembly of character units, each containing a series string connection of LED's and

one series resistor for the series string of LED's. Each series string of LED's requires a custom-valued series current-limiting resistor to determine the current resulting in the LED string, depending on the number of LED's in the series string, column 2, lines 64-66. The need to uniquely determine the value of the series resistor for each module is a disadvantage.

5 Further, US 5,020,253 provides 24V DC current and voltage in order to provide for forward voltage drop on each LED typically 1.8V for a maximum of 13 series connected LED's. In this series connection, if one of the LED's in a given character fails, then the complete character ceases to operate.

There is thus a widely recognized need for, and it would be highly advantageous to
10 have, an illuminated sign system providing

- (a) readability in the daytime, even without electrical power applied;
- (b) improved readability at night, with power applied;
- (c) improved efficiency, whether for rechargeable battery or for operation from solar cells, or for operation from city-provided power source.

15 Further, new features solving problems which have not been previously identified in the prior art are:

- (d) improved reliability, in that readability and recognizability of the information to be provided by the sign or a portion of the sign not be lost due to failure, in an electrical open-circuit condition, of a lamp element in the sign;

20 (e) easy adjustability of operating current in the field at the time of installation, especially when assembling a modular sign;

- (f) use of one power source to supply non-matching LED's, examples including LED's of many colors and LED's from various manufacturers and production lots.

25 Today, there are many signs and traffic indicators which are not illuminated, or if illuminated, the execution is inefficient and unreliable. It would be highly advantageous to have an illuminated sign system and signal technology providing for a more functional, reliable, and efficient, illuminated sign technology.

30 According to the present invention, any sign, whether a street name, residential house address, business, advertising, highway, sign, etc., would be composed of individually purchased character elements (letters, symbols spaces and/or numerals) which are adjoined physically or positionally to create the sign. Each character element is composed of a multitude of individual light sources either mounted above or below a support surface

(where there are openings for the light to exit). The individual light sources may be electrically connected in parallel or in series depending on which circuit is best matched to the available power source. The character element may also be constructed in such a way that it is visible in daylight even when "unlit", i.e., when the LED is not excited by an electric power source, and even in direct daylight (as opposed to a state of the art matrix LED sign, the message of which is only readable with the application of electrical power). The sign of the present invention may be illuminated (powered) during the day for enhanced visibility, or only at night.

If the position of the sign relative to the desired audience of observers is known, then the LED's employed may be of unique construction, as will be described, providing a directional light distribution pattern and aimed at the preferred viewing angles. Each numeral or letter element can be individually affixed to the wall or hung from an arm and individually hooked up to the electrical power or be mechanically and electrically joined to each other or to a mounting frame and then to the wall and power supply.

Alternatively, each character element could be battery powered with an optional photo-cell controlling night time operation, and the battery could be recharged from photovoltaic cells which could be located on the character element itself on its front and or back side or on a separate, properly aimed towards the sun, array.

Alternatively, a centralized power pack using utility power or with battery operation or back-up and photovoltaic recharging could be located in the frame or in a master character element in the chain, and many characters powered from it. In one implementation of the invention, letter and number modules are provided, so that one may build up a custom house sign by linking modules according to the mechanical arrangements provided, such as pins, dovetails, and slots. The mechanical arrangements include provision for electrical interconnection of the modules. Street signs, direction signs, business signs, location, and advertising signs would be modularly constructed with the ability to compose the sign at each intersection of streets or storefront from the standard letter elements.

Optionally, complete signs (as opposed to built up modular signs) custom made for a home or business would be composed in a sign factory, or may be assembled in a sign store, say, the "sign department" of a hardware store.

Due to the very low energy consumption, a number of advantages are realized, including battery back-up capability, and photovoltaic recharging allowing for use where a

commercial power source is unavailable, such as in remote highway intersections. The reduced energy use will also reduce operating costs and environmental pollution.

Readability is improved by formation of illuminated characters in which the letters stand out on high contrast backgrounds, the reverse of the case of the prior art back-lit illuminated house signs mentioned above, where the background may cause glare at night.

An additional feature of the LED sign system of the present invention is the ability for medical (ambulance), security and service operations such as taxis to receive aid in locating an address through the blinking of LED's in the sign at an address to which such services have been summoned. To this end, a special circuit capable of blinking a selected group of characters in a serially-connected LED sign. This is especially useful to ambulance drivers at night, and especially in blacked-out areas without outside lighting, such as in civil disasters or wartime but is also useful for taxi, delivery and other services night and day.

An additional useful feature is the incorporation of the postal code or other location code or information in the street and house number signs, for example, the postal code characters which are normally not being illuminated, but being trigger-able, preferably to blink for increased noticeability by remote command from an emergency vehicle, for example, say, by radio frequency or other suitable command transmission receiver incorporated in the sign.

The novel blinking-light circuit implementation of the present invention shunts a group of LED's which form the character of interest. The circuit operates to short out the group of LED's, turning off the group of LED's to cause the group of LED's to blink, the reverse of the normal turning-on of lamps to blink the lamps. The blinking-off circuit is powered from the LED-string current, not requiring a separate power supply, and thus may be located at any position along the series string.

A further important feature is the provision of a battery back-up capability, so that if there is a temporary loss of AC power to the sign, the sign will remain illuminated for some hours. In the event of loss of AC power the battery back-up would automatically be activated. A pulser circuit is preferably included to extend the battery back-up operating time. The pulser circuit would preferably be automatically enabled when the back-up battery would be in use and would be automatically reset upon restoration of the AC power. The pulser would also provide an AC power loss indicator function. In a modular system with battery back-up, the battery back-up pulser would be ideally located in the power-pack module. Illumination time may be further extended by pulsing the power applied to the

sign, so the whole sign blinks at rates which may or may not be visible to the eye. Then the operating time will be extended according to the pulsing duty ratio.

Preferably the LED's are controlled by a power cut off controller for controlling power to the plurality of LED lamps, such that the power is alternately supplied and not
5 supplied to the plurality of LED lamps, thereby causing the plurality of LED lamps to alternately illuminate and not illuminate, thereby reducing power consumption.

Another power-consumption reduction technique which may be employed in parallel circuitry is the multiplexing of characters for reduced power consumption. When characters are blinked at a sufficiently-rapid rate, the impression of constant illumination is given to the
10 observer. Thus, the possibility exists of blinking characters as a possible power-saving method, especially at night, when reduced intensity is required for visibility, due to reduced ambient illumination, compared with the daytime ambient. If additional power saving is required, an extended duty cycle at very slow rates of a number of seconds on and a number of seconds off would still leave the sign message sufficiently recognizable.

15 In addition, often street sign lighting is operated from street lighting power, which is shut off during daylight hours. In this case, battery back-up may be used to power an illuminated sign during the day if desired.

The electric circuit used to drive LED or other multiple light source signage is optimized to match the load to the power source to obtain maximum utilization of the power
20 source. When relatively few LED's are used in a sign, the separate current-balancing-resistor parallel connection of LED light sources to a low-voltage power supply - maintaining constant voltage is preferably used. Preferably, in place of the resistor, a constant current maintaining circuitry is used further increasing energy efficiency. With larger characters involving many hundreds of LED's the series connection of individual light
25 sources is preferably used, forming letters, numerals and symbols. Parallel connection of multiple strings of series-connected light sources may be used in all or some of the letters numerals and symbols making up the complete sign. The series connection utilizes a constant current source for each series string of LED's. This provides improved efficiency over parallel circuitry in such instances where the power dissipation in individual
30 parallel-LED balancing resistors becomes a factor. In an additional feature, where safety from electrical shock is desired, such as in road signs which may be knocked down in a traffic accident, the current source may be limited to a safe 30 mA and it may be optionally

fused or may alternatively include any type of circuit breaker to provide safer signage than previously available.

The features may be used in combination to realize, for example, an improved modular sign system. Merryman '579 discloses stackable modules containing lamps which are connected in parallel to the AC line, such that if one lamp fails, the character illuminated by that individual lamp is extinguished, but the rest of the characters remain lit. The circuitry of the present invention improves upon Merryman, in that the failure of one LED does not result in the loss of readability of even one character module.

Further, the modules of the present invention may preferably be connected in series to a high-voltage supply with improved efficiency. The use of a current source makes the supply current to the LED's substantially insensitive to the number of series-connected modules.

Alternatively, with a low-voltage battery supply, the modules may be supplied by individual current-mirror outputs, derived from one temperature-compensated current source.

Alternatively, a common voltage reference may be provided to each of the modules in a modular sign system, and the desired temperature coefficient for the current source in each individual module may be independently generated from the provided common voltage source.

It is important to realize that for the application of a modular system, the use of either of the current-source supplied series string connections of LED's of the present invention mentioned above is the best approach, since non-matching LED's may be readily, interchangeably used in the modules. LED's of various colors from various manufacturers and production lots may be freely assembled into interchangeable, readily-interconnectable modules. This avoids major manufacturing cost and resource difficulties. Further, temperature compensation of the LED light output versus ambient temperature may be provided by adjusting the current source temperature coefficient.

In the prior art, a disadvantage of a series connection is the continuity if one of the elements in the string fails. In the present invention, a novel series power connection reliability improvement is provided by Zener diodes bracketing groups of LED's which form the characters of the signs. Thus, if one LED in a typically series-connected string of LED's would fail open, only the loss of illumination of a portion of a character would result, resulting in a still-readable sign. Still further sign reliability is realized by multiple Zeners bracketing strings of strategically-positioned, non-consecutively positioned, light sources

comprising the character. The outage of only a single section would leave the character legible and the sign still functional. This is the "looping" connection of the present invention, described below.

In this modular sign system, signs may be constructed of individual characters in the hardware-store or in the field. A current-adjustment method must be provided to obtain optimal performance as the illumination output of a LED is a function of the forward operating current of the LED, as is well-known. Field adjustment of operating current is provided by a "go/no-go" current adjustment circuit. This circuit makes the use of an ammeter unnecessary for field adjustment of operating current in a series string of LED's at the time of installation of a sign.

Current sources are provided, including temperature-compensation for approximately constant light intensity versus temperature, with an operating temperature range centered about room temperature. The capability of economically driving multiple series strings of LED's is provided, by use of current-mirroring.

The current sources provide the capability of operation with a wide range of supply voltages, say, from 4V to 600V, without readjustment of the current-source circuitry. Thus, the current sources may be used with a wide variety of signs, containing a wide range of numbers of LED's in a series string of LED's. This is a very desirable feature, providing ease of manufacture, and interchangeability.

Both AC-line power sources and battery power sources are provided for, with efficiency-enhancement techniques. With an AC power line, the power in the bias circuitry is reduced by use of a rectifier power supply with no filter capacitor. A half-wave rectifier provides reduced power dissipation compared with a full wave rectifier. Due to the series-string LED connection, only one reverse-voltage protection diode is needed per series string, unlike the prior art parallel-connection method, in which, ideally, each diode should be provided with its own reverse-voltage protection diode. This represents a significant component and assembly cost savings. The reverse-voltage protection diode is required to guard against LED destruction due to reverse-polarity lightning-induced power-supply transients, and other AC power-line transients and surges, such as due to switching inductive loads, and due to motor starting.

Low power consumption makes possible battery operation, preferably using rechargeable batteries. Solar cell operation and is also possible as is solar cell recharging of the batteries. The mentioned use of series-string connections of the LED's results in

high-efficiency, low power consumption operation, as will be described in more detail below.

For battery-powered and battery-back-up signs, a switching power supply is provided, including an automatic adjustment feature for the voltage applied to the series string and current source, in order to maximize efficiency of the battery-powered sign system. A basic reference for the design of switching power supplies is the book, Switching and Linear Power Supply, Power Converter Design, by Abraham I. Pressman, Switchtronix Press, Waban, MA, copyright '77 by Hayden Book Company, rights transferred to Switchtronix Press, '87.

In photovoltaic recharging, if only the sign face is available to receive solar insolation (illumination), and the sign is facing north, for example, then such power reduction methods may be employed on an as-needed basis, determined in real time by diagnostic circuitry. Such circuitry determines the battery charge vs. time left of the night or section thereof to keep sign illuminated. The circuitry could use a preset calendar watch or analyze the daylight time subtracted from a 24 hour day to determine hours of night. Then, depending on the success of the solar cell charging of the batteries during the day, the circuitry would operate the illuminated sign in a maximum performance mode as long as possible, before switching to an energy saving operating mode. In addition to managing the energy use by light sources, the circuitry could manage the energy storage.

The LED's or other light sources are optimized to match the special requirements of use in signage leading to: Sign-Technology-Specific LED and LED Assemblies

In the present invention the light sources used, where possible, are specifically adapted photometrically, spectrally and physically, i.e. outer packaging, for sign and signal applications. Prior art LED's are typically designed for use as indicator lamps. Directionality is generally symmetric in the vertical and horizontal. The candle power distribution as a function of angle was also suited specifically to indicator lamp use.

The need for sign-specific LED construction will be appreciated from consideration of the following example. An LED adapted for use on a sign located at six-meter height would have no light contribution above 70 degrees from the nadir, it being assumed that the viewing audience is located on the ground, and the practical viewing distance, according to the size of the letter, is not more than 16 meters.

In the reverse case, where a sign is located at below eye level, as on the guard rail surrounding a subway exit to the street, the distribution would be above 90 degrees.

Likewise, a highway sign to be viewed by northbound traffic would be of asymmetric light distribution also about the horizontal with light projected only towards the west.

Signs to be viewed from all directions would use wide candle power distributions, while signs located at the end of a long narrow corridor would use a very narrow candle-power
5 distribution.

A two-sided bill-board sign located, for example, on the southwest side of an intersection having an almost 90 degrees, directly ahead viewing angle with traffic headed eastward and westward, and an almost zero-degrees angle to the parallel north south direction, can be made to have increased visibility to the parallel direction. Signs are visible
10 at even a light (acute) viewing angles of even 20 degrees. To make the sign more visible, narrow beam LED's forming the characters may be aimed to the left for the northbound traffic, and to the right for southbound traffic, to provide added light output, even during the day, in the viewing direction. Thus, if two or three LED's were used to form the width of a character, and one LED was directed perpendicular to the sign, a second LED directed at 20
15 degrees, and a third LED at 160 degrees, all east, north, and south-bound viewers would be getting high luminance from the sign.

Alternatively, a character formed of a single width of a special LED with the spatially desired candle power distribution, i.e., three candle-power peaks at 20 degrees, 90 degrees, and 160 degrees, could be used. On the westward face of the sign, different light
20 distribution LED's with output mostly to the west and slightly to the north would be needed for traffic coming from the west.

Similarly, on a narrow street, a storefront sign located flat above the show window could be made more visible to the pedestrians on the adjacent sidewalk by using light-sources aimed at the acute viewing angles.

25 Thus, signs with directional and bi-directional, non-normal, viewing angles, not perpendicular to the sign and LED mounting surface planes, may be realized.

The same technique applies to an information or directional sign mounted flat on a wall, such as in a narrow hospital corridor. Viewing may be enhanced by aiming method.

In addition, in characters formed using a double width of light sources, different
30 messages could be written for viewers coming from each side, approaching from each direction. For example, one could read the sign from the right, and see ENTRANCE; and from the left, and read EXIT.

An advertising sign located almost parallel to traffic could carry two different advertisements at once. Those on the way to work, eastbound, say, would see an advertisement for business computers, and for those on the way home westbound would see an advertisement for an evening news program.

5 An additional method of displaying two or more messages on a sign would entail the laying out of two or more separate character sets of the same or different color, which would be non-visible until illuminated, for example, due to the use of clear LED packages, and alternately illuminating one or the other. Thus, on a limited-sized sign, one could display the message "BUSSES" and then "ONLY" saving sign "real-estate", installation costs, and
10 energy.

An additional feature, to further make signs or signals readable, would include specifically adapting the spectral power distribution of the light energy emanating from the source to fit the application. This would include: (a) the use of different colors to emphasizes different parts of a message; and, (b) a combination of different LED's to "mix"
15 colors to render a specifically-desired color, such as white, composed of red, green, and blue. Roadway signs or indicators, which in "normal" weather use green to deliver the message, would use red LED's to provide increased visibility in fog. A radio control signal or a fog detector could control the switch-over.

The discrete light sources are used singly or are arranged in groupings to create
20 patterns which may constitute single letters, numerals, symbols, figures and pictures or complete signs. The characters are themselves constructed such that they are visible even when un-lit, i.e. not excited by an electric power source and even in direct daylight. For example, a character formed of discreet LED's is encapsulated in a plastic surround which is raised above the background surface and is shaped or molded in the shape of a character or
25 symbol. The plastic surround is made of, or coated with, a light-reflecting material and may be opaque except where the LED light is to shine through the plastic surround or be made of a translucent material.

Another embodiment would have a light-sensitive dye within the clear plastic surround, making the plastic surround into a more visible opaque character or symbol entity during the
30 day, and making the plastic surround clear again at night, with the LED's then providing the night-time character illumination.

The package options described may be realized in standard dual-in- line packages for through-hole printed circuit board mounting, and for non-through-hole assembly, using

surface-mount technology (SMT). The packages may employ clear molding compounds, as is well known, and used in custom, proprietary, camera exposure-control integrated circuits manufactured by Cherry Semiconductor Corp., 2000 South County Trail, E. Greenwich, R.I. 02818, 401-885-3600.

5 Another embodiment comprises an "electronic reflector", such as may be realized by the use of a Liquid Crystal, the opacity of which liquid crystal is controlled by the application of an electric voltage control signal to cause the randomly-oriented, liquid crystal material to align in a coherent orientation over the LED's, making the characters visible during the day. At night time, without application of electrical voltage, the randomly-oriented, semi-clear
10 liquid crystal material contained in the clear plastic surround, would allow passage of the LED's light providing the recognizable character or symbol.

In one implementation, the LED's are soldered onto a printed-circuit board. In another implementation, the LED legs are connected one to another obviating the need for a printed circuit board. The chain created can then be 1)formed into free standing character shapes
15 2)mounted into or attached onto a rigid support or 3)become part of a flexible tape or tube. Where needed Zener diodes and power components may be integrated into the chain.

In another implementation, the LED's are located on a flexible tape which contains the conductors for parallel or serial operation, with or without Zener bracketing. The tape may be formed in order to create characters or figures. The tape may come with an adhesive
20 backing for surface attachment or alternately be placed on cloth or Velcro. The cloth could then be sewn onto the apparel of night personnel, say a roadway repair crew, making the repair crew self-illuminating and thus more visible to drivers.

In another implementation, the LED chain or tape is built up into a round or trapezoidal shaped tube with the option adhesive tape along the broader bottom base surface, having
25 reflective coating along the sides, and a clear or diffusing cover along the top where the LED's may protrude through or be covered. The LED's may be aimed in the viewing direction and seen as individual point sources of high intensity along the tube such as for use in way out direction indication in smoke filled corridors. Alternately the LED's may be aimed along the tube with the tube acting as a light pipe. Specular and diffuse reflective
30 surfaces can be used as required to control the amount and direction light exitance along the tube. Alternately the LED's may be aimed totally or partially opposite to the viewing direction into a highly diffuse reflecting material to obtain a continuous light intensity along

the tubing. This reverse aiming is also ideal for the mixing of multiple individual colored LED's to generate uniformly a new color.

In another embodiment the shape of the tubing is such that it may fit into a slot or positional holes for adherence to sign surfaces. Power is supplied to the tubing via an edge connector which makes contact with the conductors at whichever point the tube was
5 snipped. At the opposite end, another edge connector is supplied to close the tube and complete the electrical circuit as is necessary for a parallel or series connection.

In another implementation the sides of the tube are covered with photocells. The photocells may be of a rigid type with gaps left between the photocells for bending, or a
10 flexible type of photocells may be used which continuously bend with the tube. For each every-so-many LED's a rechargeable battery is provided, making the product free of the need for an external power source. This self-contained tubing may be formed into characters and figures, and attached to a wall or surface of buildings and vehicles to contrive business, traffic, advertising and many other permanent or temporary signs.

15 While present LED packaging is well-suited to the original LED use in indicator lights, LED's are employed, in this invention, as elements for composing characters in signs. LED junctions are packaged in shapes that allow the formation of letters, numerals and symbols based on the contiguous placement of individual LED's. Thus, in addition to the typical prior art round-shaped packages which touch one another at a point, square or rectangular
20 shaped packages, some with angled edges to properly match up around curves in the character shape, are preferably utilized instead.

The package is also preferably redesigned to allow for optical features mentioned above, such as non-symmetric light distribution, radiation from the package at angles other than the 90-degrees angle perpendicular to the package mounting plane, and the appearance
25 of a continuum of light rather than many little dots. The same technology adaptations of package shape for character formation apply to Surface Mount Technology LED's as well.

Alternately, instead of forming characters from many individually packed LED's, multiple LED's may be packaged together in longer shape sections.

In a unique feature of the present invention, the "greatest- common-denominator"
30 shapes of letters are molded and then combined to form characters. Thus a "P" is made of a straight leg "I" and an arc similar to a backwards facing "c". Adding a leg at 45 degrees creates an "R". Thus, investment in special tooling for molds is minimized. Alternately, complete characters, numerals and symbols comprised of many LED junctions packaged in

single units may be manufactured. Properly shaped and lensed, these characters would be visible during the day and would use a minimum of LED junctions to smoothly define the character at night. The LED junctions can be aimed to directly illuminate the surface which is to be seen or by using the principles of a light tube. The LED's shine the light in to a light transmitting material where the walls are specularly mirrored except where light is to exit, thus on the back side a diffuse reflective material directs the light to exit on the front side. Such a "light bar" in the form of a character could use a minimum of LED's located along edges and be visible during the day and night.

When custom signs, i.e., those signs which are not composable via standard character elements are required, such as in the case of "one-of-a-kind" graphics signs in advertising and business signs, a unique manufacturing technology is used. In this sign manufacturing technology a specialized machine is sold to sign stores. The customer decides on the message and specific graphics of their application. The graphics are scanned into a computer or generated therein using readily available graphic programs. The graphics program would then generate silhouettes of the shapes and define the necessary placement of light sources to create the graphic. Post-processors which drive graphical plotters and computer-numerical-controlled surface-mount-technology (CNC SMT) placement machinery would then create the sign. The sign machine which would be sold to sign stores would first lay down conductors on a sign substrate surface utilizing either well-known printed circuit board masking and etching techniques, or by painting via a plotter or similar device, conductive polymers on the non-conductive substrate surface. Once the conductors are laid down in the proper graphical pattern, the CNC SMT machine would place the LED's, and solder or glue the LED's in place, to define the layout of the custom sign. The machine would optionally extrude colored plastic material around the LED's for protection and additional sign aesthetics.

Alternately, when using leg to leg connected LED chains, the scanned graphics would be translated into coordinates for a CNC punch press which would make holes for the LED's to be mounted therein. Hereinafter the term "LED chain" shall include LED tape in addition.

In high volume signs, i.e. signs carrying a standard message, again, the preferred manufacturing technology would be the mass production of complete signs as single units, rather than having the sign composed of individual character elements placed together as in the modular system mentioned earlier. In this case the LED's larger signs would be

connected in series strings, and the power circuitry prescribed earlier employed for significant energy and cost savings.

The technology of the sign system of the present invention is applied to wide range of applications using four basic packaging configurations:

- 5 1. Singular Letters, Numerals & Symbols (LNS)
2. Modular LNS
 - a) modular, mechanically and electrically interconnected "linked" separate modules
 - b) modular, framed on a rigid structure
3. Complete sign message or picture, logo, etc., such as in an advertising sign.
- 10 4. Strings, tapes or tubes of light sources which can be formed into characters, symbols or figures.

1. Singular Letter, Numeral, Symbol (LNS) or indicator elements:

Single elements may be used in house number, traffic signal and highway markers. LNS elements provide house street numbers as self-contained singly-packaged numerals. LNS
15 may be mounted on a solid back plate to control contrast and to give stability; or may be hollow and may be supported from the rear. Individual LNS elements are self-powered by a battery or connected to house power. An integral or separate array of photovoltaic solar cells may be used for daytime operation and for battery recharging, or the photovoltaic solar cells may serve as the LNS background plate, facing outwards, to gather light. The character may
20 be punched, cut or cast in plastic or metal or be carved out of wood or any other material typically used in house addresses. In a brass letter holes are punched along a center line and LED's are placed within to illuminate or a slot along the center line is filled with a plastic LED illuminated "light bar" or "light tape or tube" as previously described. The house numeral may operate continuously or may be triggered by a dawn-and-dusk-sensing
25 photocell to operate only at night. LNS may be affixed independently to a mounting surface such as a house surface or may mechanically be inter-linked with other LNS elements.

Roadway safety can be increased using the low power usage sign and signal technology described above. A pavement marker indicator element for delineating the edge of the roadway pavement consists of reflective dots "cat-eyes" in a housing with or without a stud
30 which is embedded or glued onto the pavement. Often to see the lay of the road off at a distance the driver has to put on the high beam which blinds the oncoming traffic causing discomfort and accidents. One or more directional LED's may be added to the pavement marker which would illuminate the roadway contour at a distance without requiring use of

the high beam. The LED's could be highly efficient, directional and be pulsed to minimize energy requirements allowing for photovoltaic recharging of batteries. The photovoltaic cells can be placed in front and or rear aperture of the marker and if necessary along the top and protected with a heavy-duty clear covering. An additional energy saving method would make use of a highly sensitive photocell which would pick up the low beam headlights of oncoming vehicles and only then trigger the flashing of the LED's.

In another application, a prior art reflective (unlit) highway exit sign may be retro-fitted with self-contained LNS elements which may be affixed by adhesive or mechanical fasteners over present letters to make them more visible. Further, LED's may be aimed at angles within the visibility range of drivers, increasing readability. Retro-fit of any sign to an illuminated sign is facilitated, since there is no need to be hooked up to utility power as bringing power to a remote highway sign is costly. It is possible to enhance visibility of highway traffic signs, as well as indoor direction, safety and information signs placed at very difficult viewing angles. The angled LED comes to correct for the current viewing angle deficiency. Sign location on a narrow corridor wall cannot be easily viewed from the distance because of the acute angle. With LED's angled towards the corridor axis (rather than at 90 degrees), the viewer would easily see the message. On this sign, a viewer from the left would see one message, while one viewing from the right would see another message, since the light output from one LED angled at, say, 20 degrees, would be invisible to the viewer on the other side.

2. In the modular LNS (M-LNS) there are two types of letter configurations, a stand-alone and a modular-frame type. In the modular system the function of the power supply and or mechanical securing of the individual characters is centralized

a) In the stand-alone type, characters are molded 3-D in a plastic material and are visible even when not powered. The lens end of the LED's extends out through the molded "cover" and shines making the letter visible even when there is no light. Alternately, the LED's are located beneath the cover surface. The surface material may be clear and the light of the LED's shines through or prismatic or translucent and the LED's backlight the character. The stand-alone type of individual letters blocks are attached to a base power supply block, and letters and spaces are contiguously attached to one-another, all mechanically supported by the first block. The mechanical connection may be made using fasteners, dovetail slots, pins or other mechanical and electrical linking technology.

b) In the Modular Letter and Number System (M-LNS) the sign is constructed by attaching the first letter to the power pack, which is attached firmly to the wall. The second letter is attached to the first letter with unique mechanical and electrical connections. The power pack is the physically strongest link in the modular sign system, supporting the power pack's end of the modular sign, by ruggedly mechanical mounting to the surface on which the modular sign is mounted. The last letter is optionally attached to a termination block which supports the modular sign from the termination block's end of the sign, and is similarly ruggedly mounted to the mounting surface. Alternatively, the sign may be canti-levered from one end. The circuit design allows for a very long string of symbols. Typically, this type of modular sign system is suitable for house signs, street signs, and information and directional signs.

3. Complete signs as single units, rather than having the sign composed of individual character elements placed together as in the modular system mentioned earlier is the preferred system to provide the advertising sign industry with the flexibility to scan into the computer most of the available hand-drawn or printed art work, for example, or by digitizing, as is well-known. Alternatively, computer-designed artwork may be directly used. The artwork is converted by standard graphical program algorithms, into a machine parts placement program, e.g., for use by numerical-controlled (N-C) SMT parts placement machinery, and into a corresponding N-C "wiring" program. The N-C "wiring" machine paints the electrical circuit with a conductive polymer onto the non-conductive surface of a printed-circuit-board-type material. Then the N-C parts placement machine places the SMT parts on the surface of the electrical circuit. The LED's are cemented to the circuit with the conductive polymer. Utilizing one-side surface-mount technology in the sign industry provides economical sign-making technique. Alternately, holes could be punched where through-hole LED's would be placed on a placement machine from the rear would place in the positional holes join the conducting legs and when necessary jumpers together.

BRIEF DESCRIPTION OF THE DRAWINGS

The invention is herein, by way of example only, with reference to the accompanying drawings, wherein:

FIG. 1A is an LED-formed character with Zener diodes added;

5 FIG. 1B is a "looping" LED-formed character with Zeners;

FIG 1C is a sample "looping" character foil pattern;

FIG. 1D is a dual "looping" LED-formed character with two power supplies, providing redundancy;

FIG. 2 shows a go/no-go current adjustment circuit;

10 FIG. 3 illustrates a blinking-off circuit;

FIG. 4A is a set of battery-discharge characteristics;

FIG. 4B is a corresponding plot of battery discharge time versus discharge rate;

FIG. 5A shows a current source including a current multiplier which may be used to program the operating current of a string of LED's;

15 FIG. 5E shows a negative-temperature-coefficient current source; FIG. 5F shows a variable-temperature-coefficient current source;

FIG. 5G shows a variable-temperature-coefficient current source;

FIG. 5H shows two positive-temperature-coefficient current sources;

FIG. 5I shows a saturation detector added to a current source;

20 FIG. 6A shows one current source used with a current-mirror amplifier to power multiple LED strings;

FIG. 6B shows one a current-mirror amplifier used as a current-splitter to power two parallel LED strings;

FIG. 7A shows a power supply implementation;

25 FIG. 7B shows an alternative power supply implementation;

FIG. 8A shows a prior art parallel-LED circuit;

FIG. 8B shows a series-LED power supply implementation;

FIG. 8C shows a second series-LED power supply implementation;

FIG. 8D shows details of a series-LED power supply of the second type;

30 FIG. 9A shows a directional sign, including rear solar panel;

FIG. 12 shows the novel SMT LED package molding design;

FIG. 13 shows a self-sufficient-character design;

FIG. 14 is a modular sign system using SMT-package molded LED's;

- FIG. 15A illustrates a possible custom LED package;
- FIG. 15B illustrates further possible custom LED packages;
- FIG. 16 illustrates "greatest-common-denominator" character segments.
- FIG. 17A is a multiple -LED lead-frame for parallel LED connections;
- 5 FIG. 17B shows a multiple-LED lead-frame for series LED connection;
- FIG. 17C shows a multi-colored LED sign;
- FIG. 17D shows a multi-alignment LED sign;
- FIG. 17E shows a further multi-alignment LED sign;
- FIG. 18 illustrates a directional sign, using custom LED's;
- 10 FIG. 19 illustrates a bi-directional sign, using custom LED's; and,

DESCRIPTION OF THE PREFERRED EMBODIMENTS

The present invention discloses a novel sign system suitable for use in many applications, according to the features selected to be included in the particular sign for the particular application which can be realized as modular or dedicated signs.

The principles and operation and various features of an illuminated sign or signal according to the present invention will be described with reference to the drawings, to explain how to use the invention to achieve the goal of an improved sign system with respect to readability, reliability and efficiency.

The electrical circuitry will first be considered, by way of which, the design goal of an energy-efficient sign system is realized. The circuitry includes use of current sources, to provide circuitry with a very wide power-supply operating-voltage range; Zeners shunting groups of LED's in a series-string connection of LED's, for protection against loss of message in the case of an LED failing open; looping LED string layout, for use in conjunction with the Zeners; blinking-off circuitry, uniquely powered by the series-string LED current; automatic voltage- selection circuitry in a DC-DC converter for use with battery- operation.

Following this, the novel LED and LED assemblies designs, which further contribute to an energy efficient sign system, through the effective use of electrically-generated light energy, will be discussed. Novel features in the use of "greatest-common-denominator" LED-group packaging; mixed colors of LED's in one package to achieve a desired spectral response characteristic; custom LED packages with light radiation patterns which are non-symmetric with respect to the LED die center-line, and non-perpendicular (i.e., non-normal), with respect to the LED package seating plane; integral power sources, e.g., solar cells on house signs, and on LED display strips, with back-up batteries, as well as solar-cell with batteries for remote locations.

Referring now to the drawings, Figure 1A illustrates a letter **100** formed by connecting a string of LED's **102**. The plastic lenses of LED's **102** provide readability in the daytime in ambient light. This is unlike the prior art matrix-array LED signs, in which, without electrical power applied, no character is visible. Here, however, LED's **102** alone are sufficient to provide a recognizable character. Each LED **102** includes an LED chip (not shown) in a preferably molded plastic lens-shaped package. LED's **102** are mounted in a

panel (not shown), with the packages protruding through the panel. LED's **102** are mounted in the panel to form a pattern. The resulting pattern is recognizable in daylight without requiring application of power to the LED's **102**. Readability is enhanced due to the three-dimensional structure of the package.

5 LED's **102** are connected in series, each group of four LED's **102** are shown to have a bracketing Zener diode **103** connected across the group of four LED's **102** in such a manner that Zener **103** is reverse biased. The forward voltage of an LED **102** is normally about 1.8V to 2.0V, depending on the color, hence specific semiconductor material which is employed in the fabrication of LED **102**. The breakdown voltage of Zener **103** is chosen to
10 exceed the maximum forward voltage drop of the string of LED's **102** to be bracketed by Zener **103**. Thus, for the example of four LED's **102** bracketed by Zener diode **103**, the minimum Zener breakdown voltage must be greater than, say 8V. A 9V, ten per cent tolerance, Zener could therefore be used.

A current setting resistor **105** is shown connected in series with string of LED's **102**. A
15 first connection **106** and a second connection **104** are the positive and negative supply connections, respectively. In a modular system, one option would be to provide a fixed supply voltage between the supply rails. Then each modular letter could have its internal dropping resistor to program the current inside the individual letter module. Thus, a module using fewer series-connected LED's **102** would have a larger dropping resistor (not shown).
20 This would be a factory-installed resistor for the modular sign system, with pre-manufactured modules.

Figure 1B shows an improved physical construction and wiring method for the character of Figure 1A. The improvement in Figure 1B is called "looping", due to the resulting wiring pattern appearance. In Figure 1A, LED's **102** were physically all in a row,
25 and wired in series according to the physical sequence. If one LED **102** in a bracketed group of LED's **102** would fail, a significant portion of the character would go dark. In Figure 1B, however, the wiring pattern is not in the same sequence as the physical placement of the LED's **102**. In Figure 1B, we have five "regions", **111-115**, of the illustrated character, each region containing four LED's **122**, labeled "A" through "D". As shown in the electrical
30 wiring diagram below the character, each group of LED's **122** labeled "A" thorough "D" is connected in series and bracketed by a Zener **123**. Now, from the physical arrangement, if an LED **122** in bracketed group "A" fails, the character does not lose a whole region, as would be the case in the arrangement of Figure 1A. Rather, every fourth LED **122** goes

dark, resulting in a more readable and recognizable character with the arrangement of Figure 1B than with arrangement in Figure 1A.

Figure 1C is a sample "looping" character foil pattern **130**. Pattern **130** is designed so that all LED's **132** are inserted with similar orientation, providing ease of assembly. Pattern **130** is also designed without cross-overs, also implying low assembly cost. The reason for the choice of name "looping" is readily apparent from the figure.

Figure 1D is a dual "looping" LED-formed character **140** with two power supplies, providing redundancy. Character, **140**, in Figure 1D, contains two strings, **141** and **142**, of LED's **155**. LED's **155** of strings **141** and **142**, labeled "A" and "B", respectively, alternating along the length of character **140**. LED strings **141** and **142** are powered by the AC line current as a source, **146**. String **141** is shown powered through a first rectifier **143**, by the positive half-wave rectified half-cycle of the AC line waveform. String **142** is shown powered through a second rectifier **144** by the negative half-wave rectified half-cycle of the AC line waveform. Current limiting is provided by a current-limiting resistor **145**. While one resistor is shown, shared by first rectifier **143** and second rectifier **144**, two separate resistors **145** (not shown) may alternatively be used. Also, a pair of filter capacitors **147** and **148** are shown in Figure 1D. In this redundant character construction, the redundant, separately- powered, LED strings **141** and **142** assure that in the event of a failure of one of LED's **155** as an open circuit, the character will still be readable, albeit with a "density" of the illumination of one-half of the "density" of the nominal design. More than two strings **141** and **142** of LED's **155** may be similarly provided, with separate power sources, including using all positive, or all negative, rectified power supplies, or some of each polarity.

If a character **140** of a wide or "fat" configuration is desired, with not one, but multiple LED's **155** at each "position" along the length of a character, then the redundant strings may each contain one LED from each "position".

The redundant LED strings **141** and **142** may further include series-connected strings, **141**, **142**, **150**, of LED's **155** in separate characters, **140a** - **140n**, of each character, corresponding, in effect, to a "position" of the case just described.

Figure 2 shows a go/no-go current adjustment circuit, **200**, connected in series with character string, **206**. Current adjustment circuit **200** includes a variable current-setting resistor, **205**; a fixed resistor **202** in parallel with a LED **201** similar to LED 102 of Figure 1A; a fixed resistor **204** in series with the parallel combination of LED **201** and resistor **202**;

and, an LED **203**, in parallel with fixed resistor **204** in series with the parallel combination of LED **201** and resistor **202**. LED **201** is selected to have a lower forward voltage than LED **203**. For example, LED **201** is selected to be an AlGaAs, 637nm, red LED, such as Hewlett-Packard (HP) HLMP-D101, with a forward drop of 1.8V at 20mA, and a voltage of about 1.5V at 1mA, and about 1.6V at 5mA. Resistor **202** is designed for a value such that the minimum desired lamp current equals the current in LED **201** at the forward voltage of LED **201** corresponding to the forward current, plus the current in resistor **202** with that value of LED **201** forward voltage across resistor **202**. For example, choose minimum LED string current equal to 15 Ma. If the forward voltage of LED **201** at 1mA is 1.5V at 1mA, and 1mA will be in LED **201**, then 14mA will be flowing in resistor **202**. Resistor **202** will have a value of 1.5V/14mA, approximately equal 100-ohms. Now select LED **203**, for example, HLMP- 1521, green, 569nm, GaP, with a forward drop of 2.1V at 10mA, and about 1.7V at 1mA. Select the maximum current to be 20mA. Then select resistor **204**, so that with LED **203** just lit, at 1.7V, the current in resistor **204** will be 19mA. Then 1.7V across LED **204** minus 1.6V across LED **201** gives 0.1V across resistor **204**, for a current of about 20mA in resistor **204**, so resistor **204** has a value of about 5-ohms.

Now, when variable current-setting resistor **205** is set to a high value, the current flowing from positive supply connection **106** through the current-adjustment circuit **200** and character LED string **206** to negative supply connection **104**, will be less than 15mA, and both LED **201** and LED **204**, will be off. As the setting of variable resistor **205** is advanced, and the current increases, first red LED **201** will light at about 15mA in LED string **206**, but green LED **203** will be off. As the setting of variable resistor **205** is further advanced, and the current further increases, at about 20mA in LED string **206**, green LED **203** will also light. This then indicates the maximum allowed current in LED string **206** has been reached. For safe operation, the setting of variable resistor **205** is backed off until about mid-way between the points where red LED **201** came on, and where green LED **203** came on. This results in a nominal current in LED string **206**, of about 17, a safe room-temperature value. The example given hereinabove is merely an example and the figures are therefore approximate. In a final design, temperature variations and tolerances of the diode forward voltages and resistor tolerances must be taken into consideration in order to remain safely within the device manufacturer's absolute maximum ratings for the LED string current.

The current-adjustment circuit of Figure 2 may be used internally with each character module, or for groups of modules, in a modular sign system, or for sections of a sign in a non-modular sign system.

In addition, it will be appreciated that current setting resistors **105** and **205** may be either fixed resistors or variable resistors; or, a variable resistor may first be used to adjust the operating current, and then a fixed resistor of comparable value to the adjusted resistance value may be substituted for the variable resistor.

Figure 3 illustrates a blinking-off circuit **300** of the present invention. LED's **102** are part of a series string of LED's **102** forming a character in the LED sign of the present invention. Now, it is desired to cause the portion of the sign represented by LED's **316-319** to blink on and off periodically, for increased noticeability. For example, it may be desirable to make easy the identification of the building for emergency personnel, as discussed above. A switch **313** is closed to enable operation of blinking circuit **300**. Blinking circuit **300** uses a blinking LED **310**, such as an Everlight Model F336 family blinking LED, which includes circuitry in LED package **310** causing LED **310** to blink at a pre-determined rate and duty ratio when blinking LED **310** is powered by a steady DC supply.

When switch **313** is closed, transistor **314** turns on, due to base current flow in a first resistor **312**, which is charging an initially-discharged capacitor, **311**, turning off LED's **316-319**. A second resistor **309** establishes a minimum turn-on threshold current requirement for the current in first resistor **312**, in order that transistor **314** will be turned on. First resistor **309** and second resistor **312** are typically 1200-ohms and 360-ohms, respectively. The breakdown voltage of a Zener **315** is selected to assure that capacitor **311**, typically 1microfarad, will charge to sufficient operating voltage for blinking LED **310** to operate. The minimum number of LED's **310** to be shunted to meet this requirement is about three or four LED's **310**. Without capacitor **311**, typically 1microfarad, the current in blinking LED **310**, will be too small for normal blinking operation, due to the current-limiting of the base current to transistor **314**, provided by series base resistor, **312**.

When blinking LED **310** blinks on, capacitor **311** is completely discharged. When blinking LED **310** turns off, first resistor **312** rapidly recharges capacitor **311**, so the on time of transistor **314** is only slightly longer than the on time of blinking LED **310**. The on and off times of blinking LED **310** are determined by the circuitry in blinking LED **310**. The pulse rate is about 2Hz. Once capacitor **311** has been charged to the operating voltage of

blinking LED **310**, the displacement current in capacitor **311** will be smaller than the transistor turn-on threshold current established by second resistor **309**. Thus, each time blinking LED **310** turns off, transistor **314** base current turn-on threshold requirement will not be met until blinking LED **310** internal timing circuitry turns on blinking LED **310**.

5 When capacitor **311** is charged to the operating voltage of blinking LED **310**, blinking LED **310** operates approximately according to the data sheet frequency and duty ratio.

Zener diode **315** has a further benefit inasmuch as when the simple current-setting circuits of Figures 2 and 3 are used, by way of example, significant variations in the voltage across current-setting resistor **205**, will not result due to the blinking-off of part and LED string by shorting some LED's **102** (Figure 3), resulting in blinking brighter of the other LED's **102** in the LED string. The breakdown voltage of Zener diode **315** is selected to be slightly less than the sum of the forward drops of the LED's being shunted by the blinking-off circuit, so that when transistor **314** turns on, the voltage drop across the group of LED's will be only slightly reduced, but still sufficiently reduced to extinguish the group of LED's. It is desirable for example, to simply rectify the AC power line, for example, with a half-wave rectifier **301** for the simplest off-line power supply realization, and to power the LED string in the sign system from as high a voltage as possible. Furthermore, a reverse voltage protection diode **330** is shown in Figure 3 for protecting the circuit against reverse voltage.

20 Figure 4A is a set of battery-discharge characteristics for a rechargeable battery. The curves shown are for Yuasa type NP valve-regulated lead-acid batteries, normalized to a one Ampere-hour battery. The above batteries are also known as "sealed-lead-acid" batteries, but actually have a vent to let out gas for safety, so pressure does not build up inside the battery. Looking at the 6V battery data, for the 1CA curve, the discharge curve for a discharge current in amperes equal to one times the capacity in ampere-hours, the battery voltage falls to 5.5V after about 25 minutes. At 0.6CA, the battery falls to 5.5V after about 45 minutes; at 0.4CA, about 90 minutes; at 0.2CA, about 220 minutes; for 0.1CA, about 540 minutes; for 0.05CA, about 1200 minutes.

30 Figure 4B is a corresponding plot of battery discharge time versus discharge rate for this data. As can be seen, the battery capacity is available at the twenty-hour rate, and less than half the capacity is available at the one-hour rate. From this, it is clear that the most efficient use of the battery results from a lower discharge rate, i.e., from the use of a high-resistance load to increase battery capacity. In a case where many LED's are to be

powered, as in the LED sign application, it is better to use batteries in series, at higher voltage and lower discharge rate, than in parallel at a low voltage and at a high discharge rate. Thus, in the sign system of the present invention, the choice is made to operate with as high a battery voltage as possible, and to minimize the voltage drop across dropping
5 resistors **105** of Figure 1A or resistor **205** of Figure 2.

The preferred power sources for the LED sign system of the present invention may be a battery supply, preferably using rechargeable batteries, or may be an "off-line" power supply, operating from an AC power line. Additional, less-usual power sources may be a solar-powered energy source, or may even include a windmill or any other power supply
10 driven by a force of nature.

It will be appreciated that the voltage regulation of the aforementioned power sources is not ideal. Battery voltage drops as the battery is discharged, as can be seen in Figure 4A. Improvement in the regulation of the battery output voltage would require the additional expense of a voltage regulator (not shown). The regulation of an off-line power supply
15 depends on the expense of the power supply. Since it is desirable to provide a low-cost sign system, it is desirable to provide a method of powering the LED's that is both efficient, and is tolerant of a poorly-regulated power supply.

Further, the light output of an LED is a function of the forward current of the LED. The LED forward current, like the forward current of any diode is a strong function of the diode
20 forward voltage. It is desirable therefore, to provide current regulation of the LED forward current, and not to regulate the forward voltage applied to the LED. To this end, field go/no-go current adjustment circuit **200** of Figure 2 discussed above is provided.

Recognizing the problem of the regulation of the power source to be used with an LED sign system, in view of the immediately preceding discussion, it is also desirable to provide
25 a variable, adjustable current source, which will be substantially unaffected by the variations in battery voltage with the state of discharge of the battery, or by variations in the output voltage and ripple of a poorly-regulated or poorly-filtered off-line power supply. This problem is addressed by the circuitry shown in the drawings Figures 5A-5I.

Figure 5A shows a current source, **500**, which may be used to program the operating
30 current of a string of LED's. An AD592 current source **501** requires a minimum operating voltage of about 4V, and tolerates a maximum voltage drop of 30 volts. In this range, AD592 source **501** provides an output current of 1 microampere times the ambient temperature in degrees Kelvin. Thus at 25 degrees C, the output current is 298.2 Ua,

nominal. The temperature coefficient of the output current is thus approximately positive one-third of one per cent per degree C, at about room temperature. The light output of LED's (not shown) operating at constant current is known to have a negative temperature coefficient. This fact is stated for example, in HP Application Brief I-012. The temperature coefficient of light appears to be about $-1\%/^{\circ}\text{C}$. Thus the positive temperature coefficient output current of the AD592 is beneficial in partially temperature-compensating the LED light output versus temperature. However, the approximately 300 μA output current at room temperature is much less than the desired, say, ten to twenty milliamperes forward current usually used with LED's (not shown). To increase AD592 source **501** current output to a more usable level, a current amplifier **510** is included in current source **500** of Figure 5A. Current amplifier **500** consists of transistors **502**, **503**, and **505**. In this circuit, a current-setting resistor **205** is adjusting the ratio of the collector currents of transistors **502** and **503**. Transistor **503** has an emitter area of N times the emitter area of transistor **502**. If the value of current-setting resistor **205** is zero, then the output current fed to circuits **200** and **206**, will ideally be $(N+1)$ times the output current of AD592, **501**. However the output current will be less than this, since the reference collector current in transistor **502** will be reduced by the amount of the base current required in emitter-follower transistor **505**. This problem can be solved by the use of a MOSFET in place of bipolar transistor, **505**.

These circuits for delivering a greatly-increased replica of an input reference current, although included in the general category of current-mirror-amplifier circuits, to be further discussed below with reference to Figures 6A and 6B, for the purpose of the claims, are herein defined as "current-multiplier" circuits.

Figure 5E shows an especially preferred embodiment with a very stable, negative-temperature-coefficient current source. Such a current source has a temperature coefficient of about $-0.33\%/^{\circ}\text{C}$, nominally, and is very insensitive to input power supply voltage variations. An AC line voltage **558** such as a 220V AC line, is rectified in a bridge rectifier **557**, and filtered by a capacitor **556** to provide a high-voltage DC operating voltage to power a LED string **206**. Optionally, a DC current source (not shown) may be used, thereby alleviating the need for rectifier **557** or, if desired, capacitor **556**. A resistor **555**, typically 330K-ohms, provides a reference current to a first diode **553**, a second diode **554**, and a transistor **552**, as well as base current to a high breakdown voltage transistor **551**. First diode **553** and second diode **554**, are typically 1N4007. Transistor **552** is typically 2N3904,

and high breakdown voltage transistor **551** is typically a BU902. The circuit of Figure 5E provides a very stable output current of between 10 to 30 mA, for LED strings **206** consisting of 10 to 150 LED's. The circuit may be readily constructed to accommodate a power supply operating voltage range of from 4V to 600V. Preferably, a fuse **548** is used to prevent electrocution. Furthermore, a resistor **549** is included to limit current entering into capacitor **556**.

Figure 5F shows a current source **565** with adjustable temperature coefficient of output current, as well as adjustable nominal output current. A regular "Zener" diode of 5.6V usually has a zero- temperature-coefficient breakdown voltage. This is because Zener breakdown effect, which is the breakdown mechanism below about 5.6V has a negative temperature coefficient, while avalanche breakdown effect which dominates above about 5.6V has a positive temperature coefficient. At about 5.6V, the cross-over occurs, resulting in about zero-temperature coefficient (zero-TC) of breakdown voltage at about 5.6V. In Figure 5F, a current source **565** biases a zero-TC Zener **560**, and provides sufficient base current for a transistor **561** operating at the desired LED-string current. Transistor **561** has a base-emitter voltage V_{BE} , which has a negative temperature coefficient in the neighborhood of one-third per cent per degreeC. Thus, the voltage at the emitter of transistor **561** has a slight positive temperature coefficient. The combination of a transistor **562** with voltage-divider resistors R1 **563**, and R2 **564**, provides a "VBE-multiplier" circuit. When the values of divider resistors **563** and **564** are selected for a divider string current that is large enough to be substantially unaffected by the variations of base current of transistor **562** with initial current gain, h_{FE} or beta, value, and with temperature variations of beta, then the collector-emitter voltage of transistor **562** will be its V_{BE} at its operating collector current, multiplied by a factor of $(R_2+R_1)/R_1$. Hence the name "VBE-multiplier". The voltage at the emitter of transistor **562** may be adjusted to be much less than the voltage of Zener **560**, and since the VBE-multiplier has a negative-TC voltage, as does V_{BE} of transistor **561**, the voltage across a current setting resistor **205** can be adjusted to have a large positive temperature coefficient. The adjustment of the VBE-multiplication ratio provides the temperature-coefficient adjustment capability. Thus resistors R1 **563** and R2 **564**, serve as temperature-coefficient adjustment resistors in the variable temperature-coefficient current source of Figure 5F. Current-setting resistor **205**, then provides the initial 25 degreeC current adjustment capability. A variation of this circuit could employ an electronic Zener-equivalent integrated circuit, such as TL431, with a 2.5V Zener voltage, for lower

minimum operating voltage. The required voltage across current-setting resistor **205** would have to be smaller also. With a 5.6V Zener, about 0.8V is required across resistor **205** to provide about +1%/degreeC temperature coefficient output current. With a 2.5V Zener, about 0.4V would be required across resistor **205** to provide about +1%/degreeC temperature coefficient output current.

Although in most of the figures, a variable current-setting resistor **205** is shown, a fixed resistor may be used, with its value chosen by design, or selected based on voltage measurements in the current-source circuit. For example, in Figure 5F, the value of a fixed resistor for **205** may be chosen depending on the measured actual value of the voltage of nominally 5.6Volt Zener **560**. R1 **563** and R2 **564**, may also be similarly selected.

An example set of component values for the circuit of Figure 5F is as follows: Zener(**560**) = 5.6V; transistors(**561** and **562**) = 2N3904; R2(**564**) = 1500-ohms; R1(**563**) = 330-ohms; current-setting resistor(**205**) = 82- ohms. This provides approximately 10mA at about 25 degreesC, with approximately +1%/degC temperature coefficient in the temperature range of -25C to +75C.

A variation on the adjustable temperature-coefficient current source of Figure 5F is shown in Figure 5G. In Figure 5G, the VBE- multiplier is operating with a smaller collector current, hence a smaller divider current is needed. A resistor **565** programs the VBE-multiplier current while a transistor **566** carries most of the LED-string current. Like above, the combination of a transistor **562** with voltage-divider resistors R1 **563**, and R2 **564**, provides a "VBE-multiplier" circuit. When the values of divider resistors **563** and **564** are selected for a divider string current that is large enough to be substantially unaffected by the variations of base current of transistor **562** with initial current gain, hFE or beta, value, and with temperature variations of beta, then the collector-emitter voltage of transistor **562** will be its VBE at its operating collector current, multiplied by a factor of $(R2+R1)/R1$. Hence the name "VBE-multiplier".

Figure 5H illustrates another positive-temperature-coefficient current-source design approach, which is well-suited to modular applications, or to the use of LED's requiring various positive- temperature coefficients of forward current, in order to provide zero-temperature-coefficient light output. A LM317-type, or similar band-gap voltage regulator **560** provides a zero-temperature- coefficient reference voltage. Band-gap voltage regulator **560** is powered from an appropriate low-voltage supply, LV. An LED string **206** returns to high- voltage supply HV **106**. The LED current is the collector current of a transistor **561**.

Current-programming resistor **Rset 205**, is connected from the emitter of transistor **561** to a negative supply **104**. In one implementation, the base of transistor **561** is connected directly to the zero-temperature-coefficient, 1.25V-nominal output of voltage reference **560**. Since the temperature coefficient of VBE of transistor **561** is about -2mV/degreeC, and VBE is about 650mV, the emitter voltage will be about 6000mV, and the temperature coefficient of LED string current, the collector current of transistor **561**, will be about $2/600=+0.33\%/degreeC$. In the second embodiment shown in Figure 5H, the R1 and R2 resistor divider (not shown), provides a reduced voltage to transistor **561** base, of about 0.9V, therefore resulting in about 200mV at the emitter of **561**, and an LED current having a temperature coefficient of about $2/200=+1\%/degreeC$. Figure 5I shows the addition of a saturation detection circuit **568** to a current source transistor **561** of the first Figure 5H example. Saturation detection circuit **568** consists of a differential pair of transistors **P1** and **P2**, having a series of emitter diodes **D1** and **D2**, respectively for reverse-breakdown voltage protection for **P2** provided by **D2**, and the resulting **D2** offset-voltage cancellation provided by **D1**. RLT provides the bias current for the differential pair. In normal operation, a supply voltage **106** will be great enough to hold the collector voltage of Q1 **561**, above the base voltage of Q1 **561**, so that **P2** emitter-base junction will be reverse-biased and **P2** collector current will be zero. If the high voltage supply voltage is too low, then for the case of the collector voltage of Q1 **561** approximately equal to the base voltage of Q1 **561**, **P2** will conduct collector current, sourcing I output1. This current may be applied to a following circuit for the control of the value of HV **106**. an intermediate coupling circuit may be required, such as illustrated, in which Q2, the base of which is driven by I output1, serves as a switch to turn on Dopto **569**, an LED in an optocoupler, with Rlim providing limiting of Dopto **569** LED current to an acceptable value. For the case of $R_B=RLT \times 0.7V / (LV-2.7V)$, the differential-pair "voltage-comparator" offset voltage will be approximately zero. The saturation detection circuit is a possible alternative to the current sensor circuit **87** in Figures 8C and 8D, below.

Figure 6A shows a bias-current system using one adjustable temperature coefficient current source of Figure 5G to bias a multiplicity of LED strings **206**. A go/no-go current adjustment circuit **200** is used to adjust a current-setting resistor **205** to the appropriate LED-string **206** operating current at about 25 degreesC. This current flows in LED string **206**. A current mirror amplifier (CMA) **600**, provides additional current source outputs, using the collector current of a transistor **566** as the CMA input reference current. A

transistor **601** with an emitter resistor **602**, together with a transistor **603**, serve as a voltage reference. The voltage from the positive supply line to the base of transistor **601** is the reference voltage. Emitter-follower transistor **603** provides a low output impedance for the voltage reference. When a transistor **604A** with an emitter resistor **605A** is connected across the reference voltage, then if transistor **604A** is identical to transistor **601**, and if resistor **605A** is also identical to resistor **602**, then the collector current of transistor **604A** will be substantiequal to the collector current of transistor **601**. However, for our current source, we desire the collector current of transistor **604A** to be about 25% greater than the collector current of transistor **601**. Therefore the value of resistor **605a** should ideally be 0.8 times the value of resistor **602**, and the emitter area of transistor **604A** should ideally be 1.25 times the emitter area of transistor **601**. If the voltage drop across resistor **602** is designed to be sufficiently large, however, the current matching error due to using the same emitter area for transistors **605A** as for transistor **601**, can be made acceptably small. For example, with about 0.5 volt across the emitter resistors, and equal transistor emitter areas, for an output current of 1.25 times the input current, the error should ideally be about 1%. In practice, the transistors will not be identical, and the resistors will not be identical. There will be additional errors due to the base current of transistor **603** "subtracting" from the collector current of transistor **601**, and there will be an error due to the Early effect, i.e., due to the collector-emitter voltages of the reference transistor **601** and output transistors, **604n** (not shown) not being identical. Increasing the drop across the emitter resistors **602** will help to reduce the Early voltage error. Current-mirror amplifier **600** providing multiple outputs may be used with any of the current sources described above with a current ratio of 1:1, by simply inserting current-mirror amplifier **600** in series with a positive supply connection **106**, of the current source which provides the reference current. Use of the current mirror **600** would be especially beneficial with of a battery power supply, in which case multiple strings of LED's **206** may be employed, operating at lower voltage than the voltage provided by AC line power supply operation.

Design considerations to be taken into account include the supply voltage and the number of LED's to be driven. It is desirable for example, to simply rectify the AC power line, for example, with a half-wave rectifier **301**, shown in Figure 3, for the simplest off-line power supply realization, and to power LED string **206** (Figure 6A) in the sign system from as high a voltage as possible. The typical 50Hz or 60Hz AC power line frequency is sufficiently high to give the appearance of continuous illumination of LED strings **206** with

a non-filtered power supply. The power supply expense is minimal. Also, the lack of a filter capacitor improves safety of the circuit, since there will be no stored charge in a capacitor charged to high voltage of approximately the peak value of the AC power line voltage.

5 To maintain efficiency, as low a voltage as possible should be dropped across the current-providing circuitry, where the current-providing circuitry may include a current-setting resistor **205**, a current source, a go/no-go current adjustment circuit **200**, and a current-mirror amplifier **600** circuit for the case of multiple LED strings **206**.

Use of current-mirror amplifier **600** to replicate the current programmed in one LED string **206** clearly represents a cost-saving, compared with the expense of providing
10 duplicate current-providing circuitry for each of a multiplicity of LED strings **206**.

Figure 6B shows a current-mirror amplifier used as a current-splitter **610** to power two parallel LED strings **206**. For example, in a special-module application, a special module contains a module circuitry **620** consisting of a current-splitter **610**. Current-splitter **610**, In
15 turn, is a current mirror consisting of a first transistor **601** and a second transistor **604** with a first emitter ballast resistor **602** and a second ballast resistor **605**. Module and current-splitter input current **611a**, is divided into current-splitter output currents **612** and **613**, which flow into the anode end of LED strings **206a** and **206d**, respectively. The current division ratio depends on the design of current mirror **610**, according to the current mirror
20 design principles discussed above. Current-splitter **610** output currents **612** and **613**, are summed by the interconnection of the cathode ends of LED strings **206a** and **206d** to provide a module output current **611b**, of a value equal to module input current **611a**. In an example application, two colors of LED strings **206** are to be used in one special module with each color required to operate at a different forward current, with the sum of the two
25 currents equal the special-module system string current. The design precaution which must be observed is that for proper operation of current splitter **610**, the voltage drop across LED string **206a** must always be greater than the voltage drop across LED string **206b**, in order that second transistor **604** will not saturate.

Figure 7A shows a power supply implementation incorporating a non-filtered rectifier
30 power supply for the reference for the current source which powers LED string **206**. A simple current source is shown, consisting of a transistor **561**, a current-setting resistor, **205**, a reference Zener **560**, and a bias resistor **703**. With a 220-volt AC power line, resistor **703** must be a large-value resistor to limit the current in reference Zener **560**. Due to the large

voltage drop across resistor **703**, there will be a large power loss in resistor **703**, which therefore must also be an expensive power resistor. The use of the non-filtered supply of Figure 7A, with a half-wave rectified voltage waveform at the top of resistor **703**, results in an average voltage less than half the voltage of a capacitor-filtered supply voltage resulting in less than one-quarter of the power dissipation in resistor **703**, for the same peak current in resistor **703**. Current source transistor **561** will then provide a pulsating peak current to LED string **206**. If the flickering is noticeable or objectionable with the half-wave rectified current, then the addition of a rectifier **701** and a filter capacitor **702** provides smoothing for the voltage across LED string **206**, and hence for the current in LED string **206**. Capacitor **702** may be connected either to the negative supply line or across LED string **206**, as appropriate, by connections **702a** or **702b**, respectively. Furthermore, a capacitor **710** may be added to provide a DC reference voltage at the base of transistor **561**, and hence to provide a DC current source to LED string **206**.

Figure 7B shows an alternative power supply implementation. Here a battery **704** is used to replace the high-voltage AC power source. A "switching power supply" is used in which battery **704** voltage is switched by a control circuit or oscillator **705**, and applied to primary **707** of a transformer **706**. Switching power supply techniques are well-known. Transformer **706** has two secondaries, a high-voltage winding, **711**, which replaces the high voltage AC power source, and a low-voltage winding **708**. Low-voltage winding **708** provides the reference voltage for the current source which includes a transistor **561** and a current-setting resistor, **205**. Use of low-voltage winding **708** eliminates the need for power resistor **703** of Figure 7A with the power loss of power transistor **703**. This is especially important for battery operation. In Figure 7B, the secondary voltage of winding **708** is rectified by a rectifier **709**, and optionally filtered by a capacitor **710**. Since typical switching power supply frequencies are much greater than the 50Hz or 60Hz AC power line frequencies, optional capacitor **702** would normally not be needed to suppress flickering of LED string **206**. If capacitor **702** is included, it may be connected, as discussed above, by a connection **702a** or a connection **702b**.

Figure 8A shows a prior art parallel-LED circuit, with each LED **83n** having a series dropping resistor **82n**. Assume 170 LED's, each with 1.8V drop, operating from a 2.4V battery. The efficiency depends on the design LED current, and for 7.2mA, may be calculated to be about 58% due to the power loss on the series dropping resistors.

Figure 8A also shows several reverse-voltage protection diodes **80a-80n**. Since each LED **83n** has its own dropping resistor, each LED **83n** requires a separate reverse-voltage protection diode. This is unlike the case of the series-string LED connection of the present invention, wherein one reverse-protection diode suffices for the whole series LED string. This is illustrated by reverse-voltage protection diode **330** of Figure 3 (not shown in Figure 8A).

Figure 8B shows a series-LED power supply implementation. Here, for 170 LED's connected in series, operating at 7.2mA, a transformer tap **84n** is selected to provide approximately the required total minimum operating voltage for an LED string **206** in series with a current source **85**. The efficiency of power transfer from a battery (not shown) to LED string **206** approximates the efficiency of the switching power supply, consisting of the combination of an oscillator **705** and a tapped transformer **806**, which efficiency may be about 85%. The use of a tapped transformer **806** limits the power dissipation across current source **85**, which is analogous to the prior art dropping resistors **82n** of Figure 8A, thus resulting in the increased efficiency, as well as reducing the required power rating and heat-sinking for the current-source output transistor.

Figure 8C shows an alternative to the configuration of Figure 8B. Here, a secondary current sensor **87**, provides feedback to a selector, **86**. Selector **86** automatically selects the appropriate primary tap to provide the minimum required secondary voltage to permit the desired secondary current to flow. Thus, the dissipation in a current source **85** is minimized.

Figure 8D shows details of a preferred embodiment of a series-LED power supply of the type of Figure 8C. A sensor circuitry **87**, as in Figure 8C, includes a secondary-current sensing resistor **871**, a rectifier **872**, a filter capacitor **873**, and a bleeder resistor **874**. The secondary current, whether DC, or including also AC components, is converted by resistor **871** to a corresponding voltage. A resulting rectified DC voltage is available to excite an LED **876** contained in an optocoupler **875**. LED **876** is being used, in effect, as a switch, such that when the current is sufficient to turn on LED **876**, a "digital" signal will be transferred through optocoupler **875** to a selector circuitry **86** on the primary side of a transformer **806**, as in Figure 8C.

As described, the light generated by LED **876**, couples a "digital" signal through a phototransistor **877** to the primary side of transformer **806**, providing a positive input to pin 13, the ENABLE input of a CD4017 counter to stop counting when the current through

resistor **871**, exceeds desired threshold value, which depends on the value of resistor **871**, typically 175-ohms, and on the forward drops of diode, **872** and LED **876**.

When counting is ENABLED, the clock input to pin 14, received from a clock **705**, results in the CD4017 sequentially rotating a positive output level to one of the ten outputs, 0-9, on each clock **705** pulse. Each output drives a buffer switch device, such as a transistor capable of carrying the required transformer primary current. The connections are arranged so that each subsequent clock **705** pulse will provide a smaller number of primary turns. Clock **705** thus advances the transformer primary tap connection in the direction to provide increasing transformer step-up ratio, in order to provide the lowest required secondary output voltage that will support the required secondary current flow. Thus the automatic primary-tap selector circuitry of Figure 8D accomplishes the goal of Figure 8C, of reducing the power dissipation in the system, resulting in longer battery operating time.

Saturation detector circuitry **568** of Figure 5I may be used for control of selector circuitry **86**, of Figures 8C and 8D, when a current source, such as in Figure 5H, is used in the secondary circuit of transformer **806**, to power LED string **206**.

Figure 9A shows a sign **900** which sign **900** may include a power pack **910** with electric circuitry similar to the circuitry of Figure 5E. Optionally, pack **910** includes a battery pack option (not shown) Alternatively, sign **900** includes a solar panel **901**. Furthermore, panel **901** preferably includes a rechargeable battery **902** for illumination at nighttime as well. Battery **902** is preferably charged by solar panel **901** during light hours. Sign **900** may be a remotely-located highway directional sign, relying on solar energy and rechargeable batteries for its operation. Pack **910** may also serve for battery backup options. Pack **910** in an especially preferred option, includes an AC power hook-up option.

Furthermore, sign **900** includes character modules **914** or numeral modules **916**, which can be arranged as the need arises, thus saving on overall costs of signage. Additionally, each character module **914** or numeral module **916** can be joined to a further character module **914** or numeral module **916** by a mechanical connection. Alternatively, each character module **914** or numeral module **916** can be joined to a further character module **914** or numeral module **916** by an electrical connection. Each modules **914** or **916** can be affixed to a wall or free hanging, such as hanging module **918**. Furthermore, modules **914** or **916** can be encased in a sign shell (not shown). Figure 9A also shows numeral modules **916** and character modules **914** of differing sizings, thereby enabling placing an emphasis on certain data or detail.

Figure 12 shows the novel SMT LED package molding design, **1400**. Each LED, **1401**, is mounted near bottom of molding **1401**, with electrical connections **1402**, brought out. The LED molding material contains the light-sensitive polarized material, as described above. A "lens", **1403**, may be molded above the LED mounting position. A tapered side shape **1404** of the LED **1401** housing, and one flat end **1405** of molding, **1400**, provide a daylight readable shape, and the capability of adjacently mounting the LED's **1401**, by automatic machinery to form characters.

Figure 13 shows a character **1301** consisting of a plurality of LED's **102** which may be connected in a similar way to the one shown in Figure 1A. Furthermore, character **1301** may be mounted on a backplate structure of freestanding as shown in Figure 13. Preferably, character **1301** includes a reflective surface **1320** which accomplishes two objectives. First, reflective surface **1320** enhances the amount of light viewable by a viewer after the light is emitted from LED **102**. Second, reflective surface **1320** facilitates visibility during day time conditions regardless of LED's **102** being illuminated or not. A cross-section D-D exemplifies one of the possible surface mounting modes for LED **102**. Namely, in D-D cross-section LED **102** is exposed. Alternatively, LED **102** having a lens **1330** is "flush mounted". Thus, LED **102** is inserted into character **1301** such that only lens **1330** protrudes therefrom, thereby further enhancing the light reflecting on a reflective surface **1320**. A further construction option is shown in cross-section B-B wherein each LED **102** is electrically mounted on PCB **1324**. Character **1301**, section B-B further consists of at least one light reflecting surface **1322**. Preferably light reflecting surface **1322** is either opaque or translucent for enhancing the ability of LED **102** and character **1301** to be seen by the viewer. Preferably, character **1301** also has a lens **1326** on the uppermost surface of character **1326**. Namely, character lens **1326** is substantially above LED lens **1330**. Lens **1326** can be either clear, translucent, or prismatic for diffusing light emitted by LED **102**. Occasioning on reflective surface **1322** and lens **1326** being transparent or translucent, LED **102** can be viewed from multiple angles. Furthermore, LED **102** may be constructed from material of ranging color thus further improving the signal characteristics of the sign of the present invention. Yet another possible mounting of LED's **102** in character **1301**, is shown in cross section C-C. In cross-section C-C a reflective diffuser surface **1328** is used for the purpose of diffusing the light emitted by LED's **102** which LED's **102** are aimed backwards at diffuser **1328**. When LED's **102** of a varying color is used, diffuser **1328** "mixes" the

color and produces a new color of desired wave length. The resulting new color depends upon the original colors of LED's **102**. Furthermore, character **1301**, in cross-section C-C, also includes a transparent or semi-transparent cover **1327** such that the light returning from diffuser **1328** may be seen from several angles through cover **1327**. Optionally, character **1301** may also include a larger LED **2102** for creating specialized lighting effects such as brighter areas in character **1301**. Alternatively, LED **2102** may also be of a smaller size than LED **102**. Further still, character **1301** may include one or more SMT's **1401**, like SMT **1401** of Figure 12 or even all of character **1301** will be built of contiguous SMT's **1401**. Further options include directly visible (no cover or background) free standing LED's **102** (not shown) with every LED **102** having a leg **1332** connected to a leg **1332** of an adjacent LED **102**. Alternatively, LED's **102** can be mounted and electrically connected via a printed circuit board (PCB - not shown) thereby facilitating selective illumination of LED's **102**.

Figure 14 shows a modular sign system. A character shape is mounted on a module **1500** having a contrasting background **1502**. A male electrical connection capability **1503** and a female electrical connection **1513** are also provided. A module assembly **1550** consists of a power pack **1504**, a series of modules **1500**, and an end-piece termination block **1505**, for completing a series string LED circuit that includes all the characters in the sign. Alternatively, each module **1550** may be individually supplied by a current from an output of a multiple-output current mirror (not shown in Figure 14), such as current mirror **600** illustrated in Figure 6A.

Figure 15A illustrates a possible custom LED package **1600** for providing a light radiation patterns which is both non-symmetric with respect to a conventional LED **102** die center-line (not shown). Furthermore, LED **1600** may be of a non-conventional, non-perpendicular shape with respect to LED **1600** package seating plane. A custom version of a lead- frame, such as is used in integrated circuit technology for the mounting of integrated circuit die in molded packages, is illustrated in Figure 15. Lead frame **1600**, includes a mounting pad **1601**, a first package pinend **1602A**, and a second package pinend **1602**. Both first and second package pinends **1602A** and **1603A** include a wire-bonding land areas, **1603A** and **1603B**, respectively, by which connections may be made to LED die **1604**. LED die **1604** has a plurality of exposed sides **1604a-d**, and an exposed top **1604e**, through which light is radiated, upon the passage of an electrical current through a LED junction **1605**. An arrow **1609**, illustrated emanating from the top surface **1604e** of die **1600**, is intended to represent the normal (perpendicular) to die **1600**, and to be located at the center of die **1600**.

In Figure 15, LED light-emitting junction **1605**, is located parallel to a top surface **1605e** of die **1604**, and is indicated by the dotted line along the sides of the package. Exiting light directions are indicated by the " λ " symbols. Lead frame **1600** contains a flat surface **1606**, such as would be conventionally used for the mounting an integrated circuit die, for example, by eutectic mounting or by silver- epoxy die mounting. In a conventional lead frame (not shown), a mounting surface would be planar over the whole mounting pad area.

In lead frame **1600** shown, a depression **1607** has been stamped in the center of mounting surface **1606**. Depression **1607** has a plurality of side walls, **1608a-d**, which may be formed in the stamping process to have any desired curvature and angle, thereby providing any desired, custom asymmetrical light radiation pattern with respect to arrow **1609**, to the surface of LED die **1604**, since side-facet light may be directed at any angle with respect to the die normal. The package seating plane surface is conventionally designed to be parallel to planar surface **1606**. Further, a bottom surface **1607f** of stamped depression **1607**, is illustrated to be at an angle to surface **1606**, and hence to the seating plane of the finished molded package. Thus, light may be radiated at any desired angle with respect to the package seating plane, depending on the angle of the stamping of plane **1607f**. The dotted projections of sidewalls **1608a-d**, below the bottom surface of stamped depression **1607**, marked with "X"s, show the projected position of the bottom of the depression if the depression were stamped out with bottom surface **1607f**, parallel to surface **1606**. Thus, custom sign LED's **1600**, with any generalized, desired, light radiation pattern and angle are provided, such as are used in directional-viewing-angle and bi-directional-viewing angle, sign applications, as described above, in the section titled, Sign-Technology-Specific LED and LED Assemblies.

Figure 15B illustrates a group of possible configurations having a fixed angle body. A LED **1645** has a fixed angle body of substantially 45 degrees thereby facilitating creation of patterns by merely connecting a side **1648** to a side **1648** of an adjacent LED **1645**. A LED **1660** having a fixed angled body of substantially 60 degrees may also be used solely with other LED's **1660** or conjunctively with LED **1645** described hereinabove above to create the desired shape of a character or a numeral. A LED **1690**, having a fixed angled body of substantially 90 degrees may be used as well. Like above, LED **1690** can be used solely with other LED's **1690** or in any combination with LED's **1645** and **1660** for creating characters and numerals of any desired shape. Optionally, LED's of any angle can be used to construct figures and characters with varying configurations.

Figure 16 shows a straight LED **1710** having a side length **1712** and a side width **1714**. For the purpose of forming characters and numerals, side length **1712** is at least twice the dimension to side width **1714**. A curved Led **1720** is also shown wherein curved LED **1720** is preferably of a half-circle configuration. Furthermore, curved LED width **1724** is substantially equal to straight LED width **1714**. Thus by using a single straight LED **1710** and two curved LED's **1720** a sign of the letter "B" is achieved. This curved LED's **1720** and straight LED's **1710** of varying dimensions can be used to create virtually any numeral or character. Optionally, LED **1710** and curved LED **1720** may be constructed of several LED junctions (not shown).

Figures 17A and 17B show a plurality of LED's having differing colors of bodies in one package for achieving a desired spectral response characteristic. Specifically, adapting the spectral power distribution of the light energy emanating from the source to fit the application may make signs or signals more readable. This would include: (a) the use of different colors to emphasizes different parts of a message; and, (b) a combination of different LED's to "mix" colors to render a specifically-desired color, such as white, composed of red, green, and blue; or, as disclosed in US 5,450,301, the appearance of amber results at a distance, from using closely-packed red and green LED's in a ratio of one red to two green LED's. The packaging of multiple, various-color LED's in one package, puts the LED's in very close proximity, so the merged-color effect will be effective from a closer viewing distance. Roadway signs or indicators, which in "normal" weather use green to deliver the message, would use red LED's to provide increased visibility in fog. A radio control signal or a fog detector could control the switch-over.

Figure 17A illustrates a lead frame **1801**, having a die-mounting area **1802**, accommodating a LED die **1803**. Each of the six LED dies **1803** shown, has a wire-bond connection to a lead-frame package-pin connection wire-bonding area, **1804**. LED dies **1803** are mounted, typically, with silver- epoxy, resulting in an electrical connection from the reverse of each of die **1803** to a mounting pad **1802**, shown connected to two diagonally-opposite package pins. Figure 17B shows a lead frame **1821** with four mounting pads **1822a-d**, each accommodating an LED die **1823**. This type of multiple-mounting-pad lead-frame design is required for a completely-series-string-connectable multiple-LED assembly, since the common connection of one terminal of a multiplicity of LED's implies a parallel connection. Thus the Figure 17A lead-frame **1801** assembly is for parallel circuits, and lead-frame assembly **1821** such as in Figure 17B is required for use in series-string

connections of the LED's contained in the package facilitating the multiple junction LED of Figure 16.

Figure 17C shows a plurality of first colored LED strings **1830** forming a series of characters or numerals. A plurality of second colored LED strings **1840** forming additional characters or numerals are also shown. Owing to the differentiation in color between strings **1830** and **1840**, a viewer may be better informed. By way of example only, first LED strings **1830** form the word "BUSSES" in Figure 17C while second LED strings **1840** form the word "ONLY" thereby facilitating an intermittent illumination of strings **1830** and **1840** such that drivers will not enter a lane reserved for busses only.

A further possible mounting system is shown in Figure 17D wherein each character **1848** is comprised of several types of LED's. A left facing LED **1850** and a right facing LED **1860** are shown which LED's **1850** and **1860** facilitate an altering view as a viewer approaches and passes each character **1848**. Optionally, a center facing LED **1855** may also be used to create even further lighting effects.

A specific example of such a use is shown in Figure 17E wherein left facing LED's **1850** form the word "EXIT" while right facing LED's **1860** form the word "ENTRANCE". Thus, a viewer approaching from the right sees the word "entrance" while a viewer approaching from the left is an indication of the whereabouts of the exit.

Figure 18 shows a directional sign **1900** using the lead frame of Figure 15. Sign **1900** has a mounting surface **1901**, on which a series of LED packages **1902** containing custom LED lead frames and having a die mounting surface **1903**. Die mounting surface **1903** is angled with respect to mounting surface **1902**. The resulting optimum sign **1900** viewing angle depends on the package orientation on mounting surface **1902**. For example, if Figure 18 is a top view, then the best sign **1900** viewing angle is from the left side of the page, and it will be difficult or impossible to read the sign from the right side of the page. If, on the other hand, the right side of the page is "up", then the sign is an overhead sign, with the light output of the sign most effectively used by being directed below, to the viewers passing under the sign. In either case, the energy put into powering the sign has most effectively been used by directing the energy in the most useful direction.

Figure 19 shows a bi-directional sign. Figure 19 adds alternating rows of packages **2002** between rows of packages **1902**. Packages **1902** are illustrated as having the same orientation as in Figure 18, while packages **2002** are oriented for light radiation at an angle of 180- degrees to the light-radiation direction of packages **1902**. If identical LED packages

with identical lead frame mounting areas are used for packages **1902** and **2002**, then lead frame mounting areas **2003** in packages **2002** are at the negative of the mounting angle of the lead frame mounting areas in packages **1902**. In general, different angles may be provided for lead frame die mounting areas **1903** and **2003**. The packages **1902** are connected together as appropriate to display a first message, and the packages **2002** are connected together to display a second message. The first message displayed using packages **1902** is optimally viewable from the first viewing angle, while the second message displayed by second packages **2002** is optimally viewable from a viewing angle, θ_2 , which is the negative of the first viewing angle, θ_1 , for viewing angles measured with respect to the normal (perpendicular) to the package seating plane, **2001**. As mentioned above, the viewing angle, θ_2 , may, in general, be different from the negative of viewing angle, θ_1 , if the package die mounting area, **1607f**, in packages **2002**, has an angle different from the die mounting area angle in packages **1902**.

Figure 20 illustrates a circuit for turning on an LED character in a sign, the character consisting of a series-string connection of LED's, not normally being illuminated. In the absence of a +turn-on command at the base of Q2, Q2 will be non-conducting. Thus, R2 will bias Q3 on, holding off voltage reference, VR1. Thus, the output voltage of the voltage reference will be zero, RB will act as a safety pulldown and bleeder resistor to hold off Q1, and no current will flow in LED string, **206**. Upon receipt of a +turn-on command, and while the turn-on command remains active, Q2 will be held on, holding off Q3, enabling Voltage reference, VR1 to turn on and to provide the voltage VREF at the base of Q1, thereby causing a forward LED string current, ILED, to flow, illuminating the character represented by LED string **206**.

While the invention has been described with respect to a limited number of embodiments, it will be appreciated that many variations, modifications and other applications of the invention may be made.

In particular, incandescent lamps, single crystal solid state light sources, as well as LED's may be driven from a current source or from a current programmed according to the method and with the circuitry of the present invention. Thus, while the claims state "LED's", the claims should be understood to apply to incandescent lamps, also, and to any other light source which may be driven according to the present invention.

WHAT IS CLAIMED IS:

1. A sign system comprising a series-string connection of LED's, and a Zener diode shunting a group of LED's in said series-string connection of LED's.
2. A sign system as in claim 1, further comprising looping layout construction of said series-string connection of LED's.
3. A sign system as in claim 1, further comprising a current supplied to said series-string connection of LED's, and a blinking-off circuit shunting a group of LED's in said series-string connection of LED's, said blinking-off circuit powered by said current supplied to said series string connection of LED's.
4. A sign system as in claim 1, further comprising a go/no-go current-adjustment circuit.
5. A sign system comprising a series-string connection of LED's and a current source for supplying current to said series-string connection of LED's.
6. A sign system as in claim 5, further comprising a Zener diode shunting a group of LED's in said series-string connection of LED's.
7. A sign system as in claim 5, further comprising looping layout construction of said series-string connection of LED's.
8. A sign system as in claim 5, further comprising a blinking-off circuit shunting a group of LED's in said series-string connection of LED's, said blinking-off circuit powered by said current supplied to said series string connection of LED's.
9. A sign system as in claim 5 said current source for supplying current to said series-string connection of LED's further comprising at least one resistor selected from the group consisting of a current-setting resistor, and a temperature-coefficient-of-output-current-adjusting

resistor.

10. A sign system as in claim 5, further comprising a go/no-go current-adjustment circuit.
11. A sign system as in claim 5, further comprising at least one additional circuit selected from the group consisting of a current- mirror amplifier circuit, a current-splitter circuit, and a current- multiplier circuit.
12. A sign system, comprising
 - (a) a sign;
 - (b) a battery for powering said sign, said battery having a battery voltage;
 - (c) a DC-DC converter for providing a DC-DC converter output voltage, said DC-DC converter using said battery voltage as an input voltage; and,
 - (d) a sensor for automatic DC-DC converter output-voltage adjustment.
13. A sign system as in claim 12, wherein said sensor is selected from the group consisting of a current sensor and a saturation detector.
14. A sign system as in claim 12, further comprising a switching power supply including a transformer having a secondary winding for providing a reference voltage for said current source.
15. A sign system as in claim 12, further comprising a pulser to increase battery back-up operation time.
16. A sign system as in claim 12, further comprising a battery operated power supply including a transformer with a tapped low voltage primary winding for control of secondary voltage, said battery operated power supply including automatic primary-tap selector circuitry. said automatic primary-tap selector circuitry including current-threshold detection circuitry for detecting presence of a minimum desired threshold current, a counter and a clock providing clock pulses to said counter, said counter providing a sequential tap-selection output on each subsequent clock pulse, each said sequential tap selection output resulting in a higher output voltage, until said

current-threshold detection circuitry detects the presence of said minimum desired threshold current, whereupon said current threshold detection circuitry stops the counter.

17. A sign system as in claim 12 wherein said battery is automatically activated and reset.
18. A sign system as in claim 15, wherein said pulser is automatically activated and reset.
19. A sign system as in claim 5, further comprising a non-filtered reference power supply for said current source.
20. A sign system comprising "greatest-common-denominator" character elements for combining into characters.
21. A sign system as in claim 8, wherein said blinking-off circuit is connected to periodically short out a group of LED's.
22. A method of current adjustment comprising
 - (a) providing:
 - (1) a go/no-go current adjustment circuit, including first and second series-connected resistors, and first and second LED's, said first LED connected in parallel with first said resistor, and said second LED connected in parallel with the series combination of said series connected resistors, and,
 - (2) a current-setting resistor;
 - (b) adjusting said current-setting resistor to a first resistance value such that said first LED lights;
 - (c) adjusting said current-setting resistor to a second resistance value such that said second LED lights; and,
 - (d) adjusting said current-setting resistor to a resistance value between said first and second resistance values.
23. A sign system as in claim 5, further comprising a flexible tape strip, the LED's mounted on said flexible tape strip, the LED's being inserted in holes in a panel,

thereby forming pattern of LED's representing a character; the areas surrounding the holes further being painted to represent said character represented by the LED insertion pattern, whereby said character is readable in the daytime without power applied to the LED's, and readable at night with power applied to the LED's.

24. A sign system as in claim 5, further comprising a printed circuit board, the LED's mounted on said printed circuit board, the LED's being inserted in holes in a panel, thereby forming a pattern of LED's, representing a character; the areas surrounding the holes further being painted to represent said character represented by the LED insertion pattern, whereby said character is readable in the daytime without power applied to the LED's, and readable at night with power applied to the LED's.
25. A sign system as in claim 5, further comprising a reverse-voltage protection diode for said series-connected string of LED's.
26. A method for adjusting the temperature coefficient of a variable temperature coefficient current source for LED's, comprising
 - (a) providing a variable temperature coefficient current source, including
 - (i) a current-setting resistor;
 - (ii) a temperature coefficient setting resistor, the value of which, in part determines the temperature coefficient of the voltage across said current setting resistor; and,
 - (iii) a voltage reference, the voltage of which, in part determines the temperature coefficient of the voltage across said current setting resistor;
 - (b) calculating a voltage across said current setting resistor required at a reference temperature to provide a desired temperature coefficient current source;
 - (c) measuring said reference voltage at said reference temperature, and adjusting said temperature coefficient adjustment resistor to provide said required voltage across said current setting resistor at said reference temperature;
 - (d) adjusting said current setting resistor to provide a desired current value having said desired temperature coefficient.

27. A sign system as in claim 5, further comprising modules, said series string connection of said LED's including a series string of LED's including said LED's in said modules connected in series.
28. A sign system as in claim 5, further comprising a wide-viewing angle traffic signal including individual sunshades for each of the LED's, each said sunshade having an angled front end, said angled front end further having an inner surface coating of reflective material.
29. A sign system as in claim 5, further comprising a self-sufficient-character design including said LED's mounted on a solar cell background, and further including a power pack.
30. A sign system as in claim 5, further comprising LED's in a hole-through or SMT molded package including molding material including light-sensitive polarized material including where such hole-through or SMT LED's are affixed to a printed circuit board or including where there is no printed circuit board but rather the conductive leads (legs) of one LED is soldered or spot-welded in series to the leads (legs) of another LED.
31. A sign system as in claim 30, said molded package further comprising at least one feature selected from the group consisting of tapered sides, a lens, and reflective coating applied to said tapered sides.
32. A sign system as in claim 12, further comprising a battery operated power supply including a transformer with a tapped high voltage secondary winding.
33. A sign system as in claim 5, further comprising redundant, separately-powered, LED strings.
34. A sign system as in claim 5, further comprising a command receiver for receiving a remote command to trigger illumination of a character, said character including a said

series-string connection of LED's, said character including said series-string connection of LED's normally not illuminated.

35. An illuminated sign composed of an individual character elements where such character is composed of individual light sources which are adjoined physically and positionally to create the letter, numeral, symbol or figure where said characters are adjoined physically and or positionally to create the sign.
36. Said character of claim 35 where character element is constructed in such a way that it is visible in light even when not powered including at least one of the features selected from the group consisting of:
 - a) A raised character shape of translucent material which is visible in daylight and allows the light emanating from the source to be seen at night.
 - b) A raised character shape of opaque light reflecting material except for a lens of clear, prismatic or translucent material which allows for light generated by the light source to exit.
 - c) A light-reflective material visible during daylight placed or painted in the character shape aside the light emitting zone of said character shape.
 - d) A character shaped by visible LED elements where such LED's are packed in different geometric forms which, when placed contiguously form the complete character and where each LED is itself having at least one of the features selected from the group consisting of:
 - (1) a light-reflecting skirt and light transmitting lens;
 - (2) a combined LED and LCD element with a LCD placed above, i.e. between the viewer and the LED which said LCD, when powered, allows for daylight visibility; and, when not powered, allows LED light to emanate.
37. A free standing LED character elements of thin character width which may be placed over highway sign characters making the character illuminated at night while still leaving the original retro-reflective material to reflect oncoming headlights or a complete LED illuminated character affixed over the present character or on a totally new sign.

38. A LED constructed for use in signs where the light candle power (CP) distribution pattern is optimized by LED having at least one feature selected from the group consisting of:
- a) a reflector giving symmetric or asymmetric CP distribution about the horizontal, vertical or both horizontal and vertical;
 - b) a lens giving a symmetric or asymmetric CP distribution about the horizontal, vertical or both horizontal and vertical;
 - c) a combination “reflector-lens” - optical arrangement giving an asymmetric CP distribution about the horizontal, vertical or both horizontal and vertical;
 - d) a canted LED package allowing for the LED to be placed regularly (perpendicularly) on a sign surface but having the light exit downward towards the viewing audience;
 - e) constructing the “reflector-lens” optical arrangement and the LED such that it gives 3 peak CP intensities: one for viewers from the left and one for viewers straight ahead;
 - f) constructing the LED as in e) by using more than one LED junction where each junction can be a different color where each junction can be individually operated;
 - g) constructing the LED as in f) without respect to peak intensity distributions as in e) for the purpose of switching between different color LED's or their combined operation to obtain color mixing and generate new colors.
39. An optical system for the formation of sign characters where LED's light is first carried and then re-directed in the viewing direction constructed by including at least one of the features selected from the group consisting of:
- a) a light transmitting material which carries the light along the character shape with the surface opposite made non-internally reflecting by being etched or ground such said surface being coated with a diffuse reflective material. The surfaces perpendicular to the viewing direction at points of curvature can be coated with a specular reflecting material to aid in light transmission and the observed surface is either left smooth or is etched or ground;

- b) a sign as in claim 36 where LED's are aimed totally or partially opposite to the viewing direction into a highly diffuse reflecting material to obtain a continuous light intensity along the character;
 - c) a sign as in b) above where multiple individual color LED's are aimed in the reverse direction to obtain color mixing.
40. A sign system as in claim 5, further comprising a cat's-eye type sign, including at least one feature selected from the group consisting of a solar-cell recharged storage battery power source, and headlight detectors, and a mounting background of retro-reflective light-reflecting material one or more LED's.
41. A sign system as in claim 5 further comprising custom LED packages including custom lead frames, said custom lead frames including at least one feature selected from the group consisting of a die-mounting area which is at an angle to the finished-package seating plane, a depressed mounting area including side walls formed to act as reflectors, a die-mounting area accommodating multiple LED's, and separate electrically-isolated die-mounting areas.
42. A sign system comprising SMT-packaged LED's mounted on a substrate having a non-conductive surface, electrical conductors provided on said non-conductive surface of said substrate, said LED's interconnected by said conductors on said surface.
43. A sign system as in claim 42, including SMT-packaged LED's mounted on a substrate having a non-conductive surface, wherein said conductors include a conductive polymer screened onto said non-conductive surface of said substrate, thereby forming screened-on conductors on said surface, said LED's interconnected by said screened-on conductors on said surface.
44. A method for manufacturing SMT signs comprising
- (a) providing:
 - (1) a sign substrate
 - (2) artwork representing the design to be displayed on said sign substrate

- (3) SMT parts, including custom LED SMT-packaged LED's, to be mounted on said substrate, for use in providing said design to be displayed
 - (4) numerical-controlled (N-C) SMT parts placement machinery for placing said SMT parts on said substrate
 - (5) a program containing an algorithm for converting the artwork into digital data for use in placement of said SMT parts by said numerical-controlled SMT parts placement machinery
 - (b) entering said artwork as input into said program containing said algorithm,
 - (c) using said program to obtain said digital data
 - (d) using said digital data as input to said parts placement machinery
 - (e) using said parts placement machinery for placing said parts on said substrate.
45. A method as in claim 44, further comprising
- (a) providing:
 - (1) conductive polymer for interconnecting said parts
 - (2) capability of said parts placement machine to paint conductive polymer on said substrate
 - (3) a routing algorithm for providing routing data of said conductive polymer on said substrate, for provision of conductive-polymer conductors
 - (b) using said routing algorithm to obtain said routing data
 - (c) using said numerically-controlled SMT machinery for painting said conductive polymer on said substrate, according to said routing data provided by said algorithm prior to placement of said parts on said substrate.
46. A sign system comprising a flexible tape of mechanically and electrically joined SMT or hole-through LED elements with adhesive backing.
47. A sign system as in claim 46, further comprising a bend-able strip which allows free standing said flexible tape to maintain a desired shape once said shape is formed by bending.
48. A sign system as in claim 47, wherein said bendable strip is selected from the group consisting of said adhesive layer and a soft bend-able metal strip.

49. A sign system as in claim 46, wherein said flexible tape includes a flexible tube with u-shaped bottom and semi-circular top or trapezoidal cross section, said cross-section including semi-circular or slanted sides, said sides providing a reflective surface for daylight viewing; said flexible tube having an upper surface having at least one feature selected from the group consisting of a clear top cover, a prismatic lens, and a diffusing lens.
50. A sign system as in claim 49, including said flexible tube, further comprising
 - (a) a solar cell along said upper side surfaces; and,
 - (b) a rechargeable battery and associated power control circuitry mounted within said tubing.
51. A sign system as in claim 5, further comprising a battery operated power supply including a transformer with a tapped high voltage secondary winding.
52. A sign system as in claim 5, further comprising a switching power supply including a transformer having a secondary winding for providing a reference voltage for said current source.
53. A sign system as in claim 5, further comprising, a current source; a multiple-output current mirror for receiving an input current from said current source and for providing multiple current-mirror output currents; and modules, each said module containing a said series string of LED's, each said module receiving a said current-mirror output current.
54. The sign of claim 45, wherein said substrate is painted with contrasting daylight paint.
55. The sign of claim 45, wherein said substrate is formed with cavities receptive to a LED's.
56. The sign of claim 45, wherein said substrate is formed with cavities receptive to an LED tape.

57. A sign system comprising a plurality of LED's and including at least one of the features selected from the group consisting of
- (a) a series-string connection of said LED's;
 - (b) a Zener diode bracketing a group of said LED's;
 - (c) a blinking-off circuit shunting a group of LED's in a said series-string connection of said LED's;
 - (d) a go/no-go current adjustment circuit;
 - (e) a current source;
 - (f) a current-setting resistor;
 - (g) a current-mirror amplifier;
 - (h) a non-filtered rectifier power supply;
 - (I) a looping pattern of LED interconnection;
 - (j) a back-up battery with a high-resistance load to increase battery capacity;
 - (k) a pulser to increase battery back-up operation time;
 - (l) a temperature-coefficient setting resistor;
 - (m) a current amplifier; and,
 - (n) a current splitter.
58. A current source for inhibiting electrocution comprising:
- (a) a line voltage;
 - (b) an LED string electrically connected to said line voltage;
 - (c) a first diode;
 - (d) a resistor for providing a reference current, electrically connected to said first diode;
 - (e) a transistor electrically connected to said line voltage; and
 - (f) a high breakdown voltage transistor.
59. The source of claim 58 wherein said line voltage is an AC line voltage.
60. The source of claim 59, further comprising:
- (g) a bridge rectifier for rectifying current from said AC line voltage; and
 - (h) a capacitor for filtering current from said bridge rectifier.

61. The source of claim 60, further comprising a fuse for preventing electrocution.
62. The source of claim 61, further comprising a resistor to limit current entering into said capacitor.
63. The source of claim 58, wherein said source provides a stable output current of 10 to 30 mA.
64. The source of claim 58, wherein said source accommodates a power supply operating voltage range of 4 - 600 Volt.
65. A sign where within the same surface area two or more messages, via symbols or words, are spelled out. Said different words are visible only when alternately powered and where the words are of the same or different color emitting LED's.
66. A sign where within the same surface area two or more messages, via symbols or words, are spelled out with each word comprised of characters using LED's having a narrow light distribution aimed at viewers coming from one direction not visible to the viewers coming from the other direction.
67. An LED light, comprising:
 - (a) an LED chain;
 - (b) at least one LED light being contained in said LED chain
68. The LED light of claim 68 wherein said LED chain has a cross-section of a shape selected from the group consisting of triangular, circular and trapezoidal.
69. An LED circuit for reducing power consumption, comprising:
 - (a) a plurality of LED lamps; and
 - (b) a power cut off controller for controlling power to said plurality of LED lamps, such that said power is alternately supplied and not supplied to said plurality of LED

lamps, thereby causing said plurality of LED lamps to alternately illuminate and not illuminate, thereby reducing power consumption.

70. A light tube, comprising:
- (a) a plurality of LED lamps; and
 - (b) a tube, said LED lamps being contained in said tube, said tube featuring at least a portion cut away such that light from said plurality of LED lamps is illuminated from said cutaway portion such that passage of light through said cutaway portion is permitted and such that passage of said light through substantially any other portion of said tube is blocked.
71. The light tube of claim 70, wherein said tube is shaped in a form of a character, such that passage of said light through said cutaway portion illuminates said tube in the shape of said character.

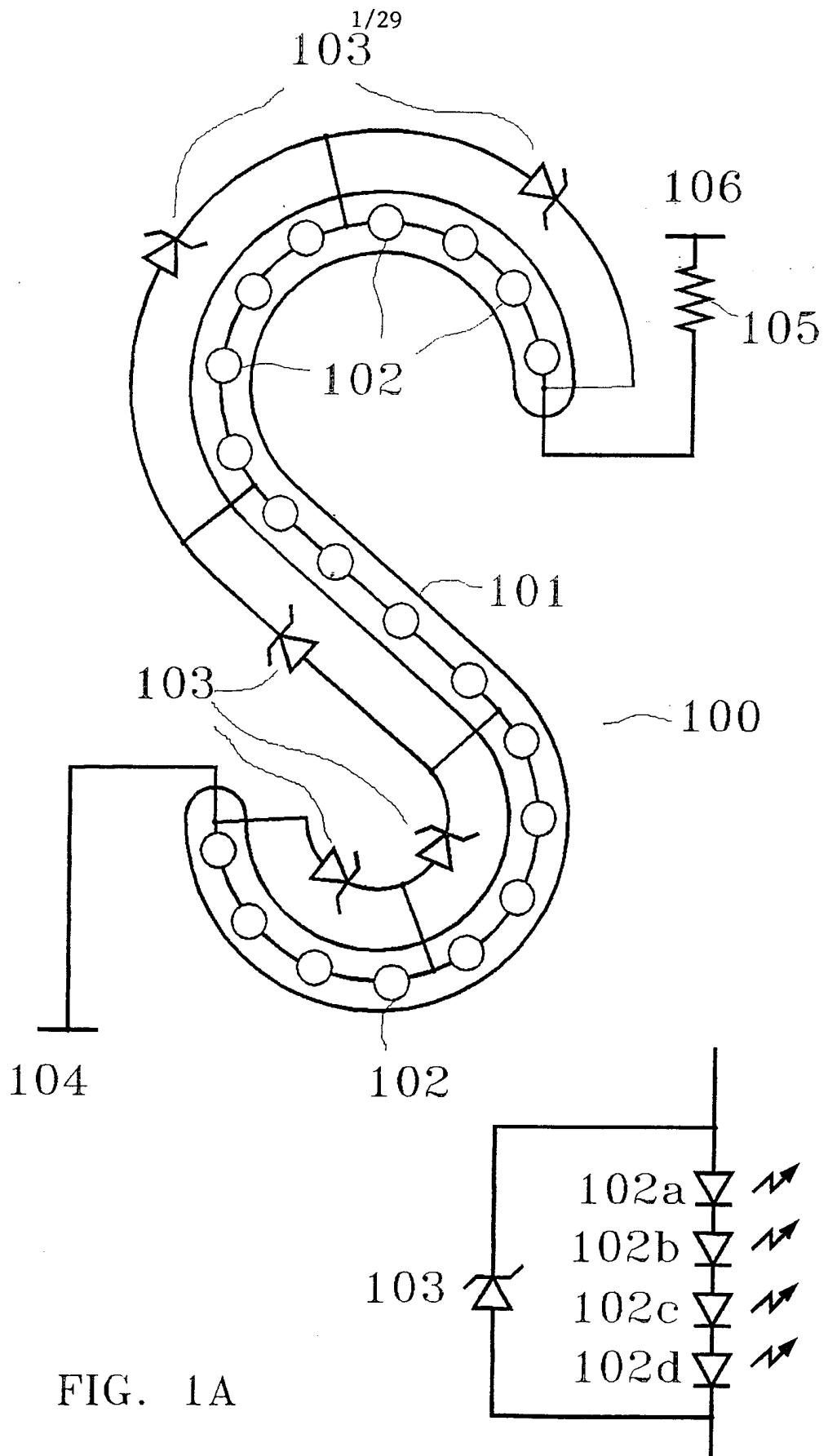

FIG. 1A

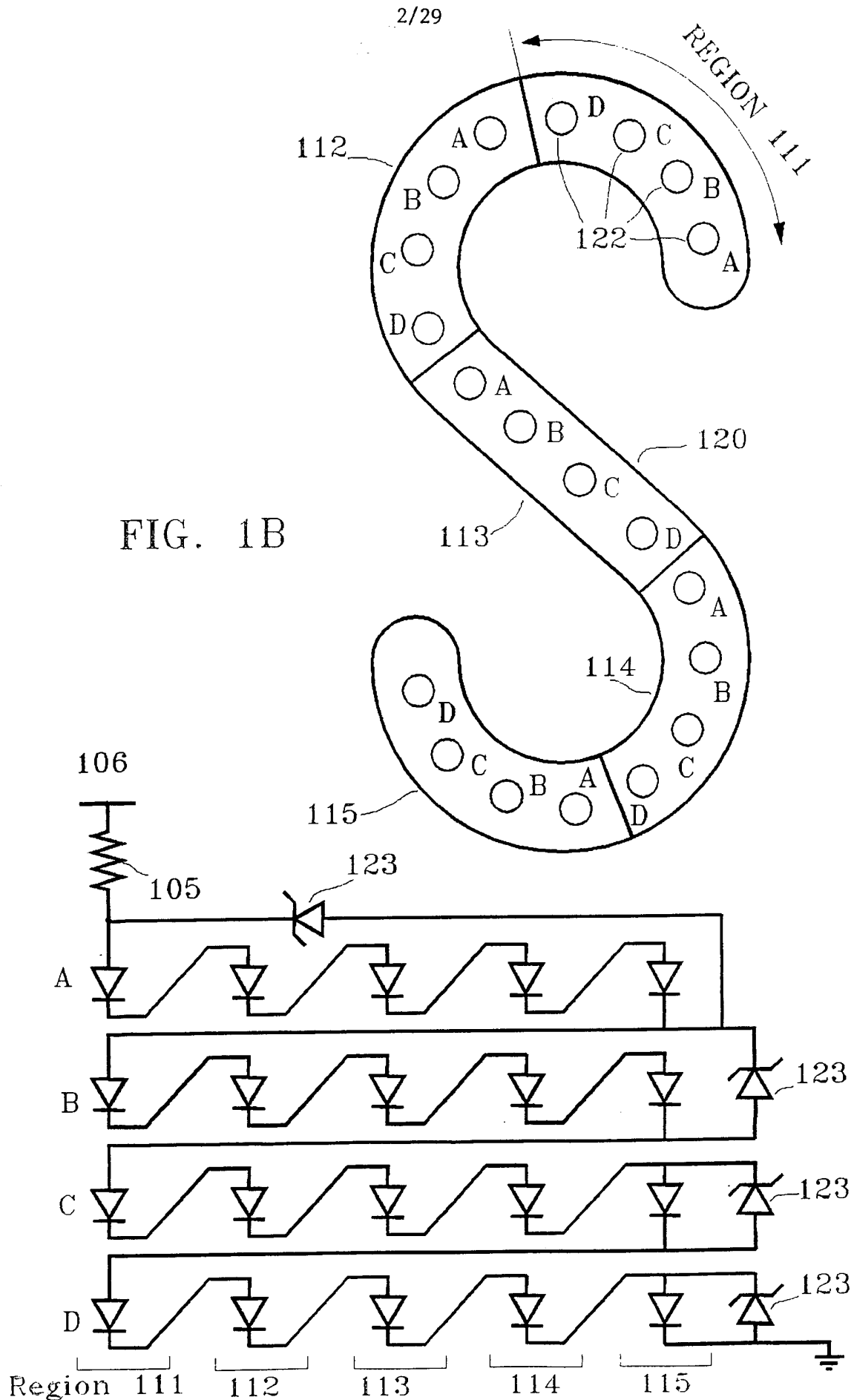

FIG. 1B

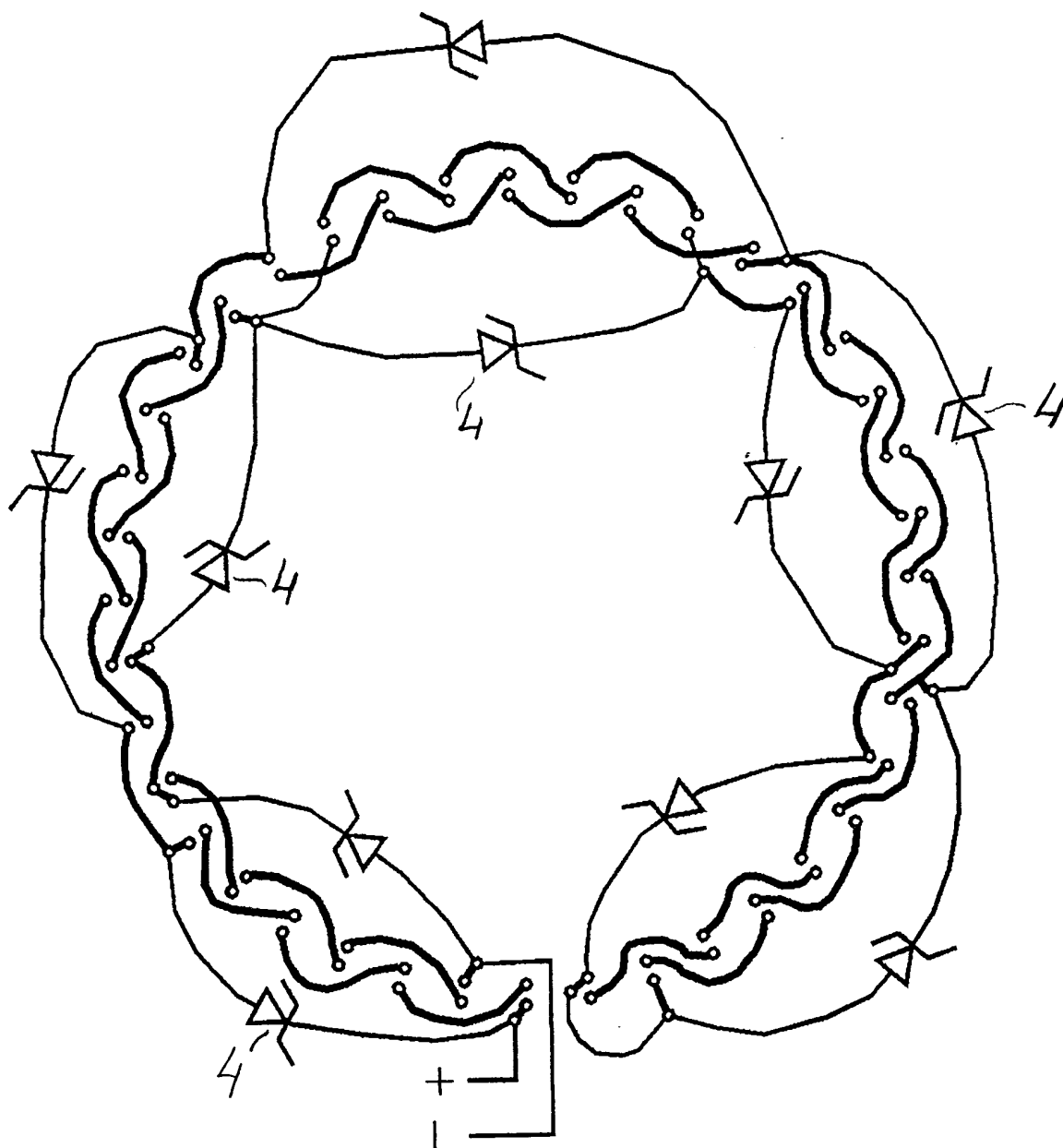

FIG. 1C

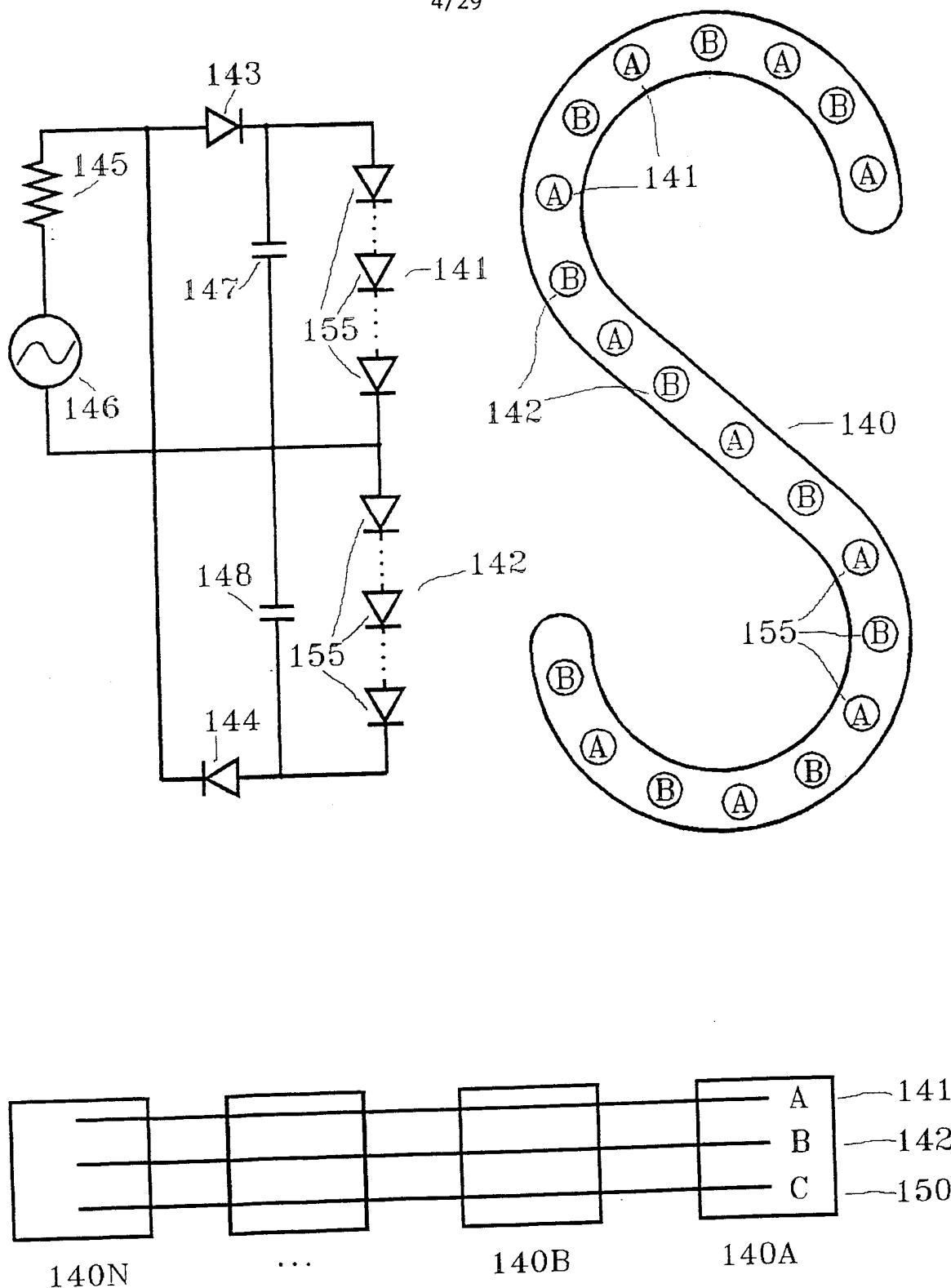

FIG. 1D

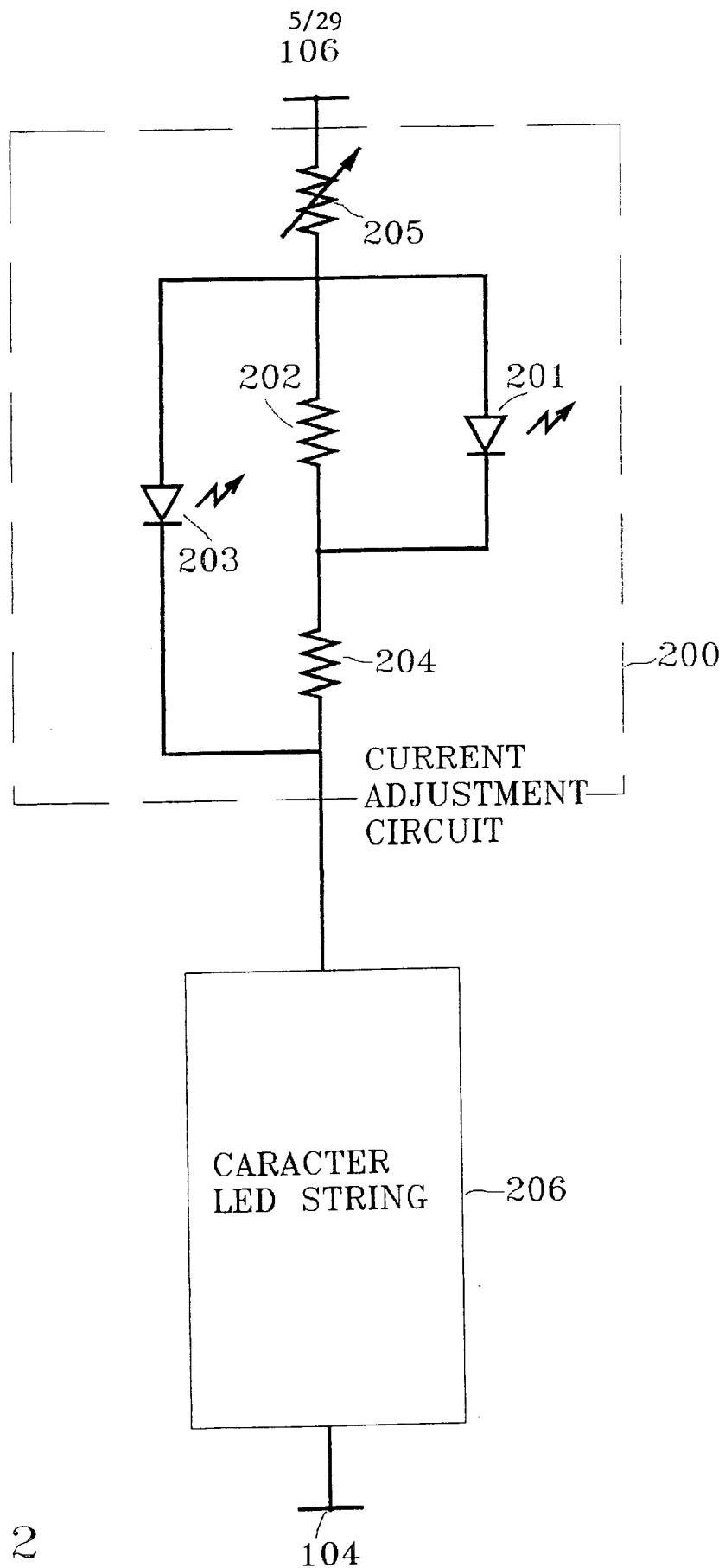

FIG. 2

6/29

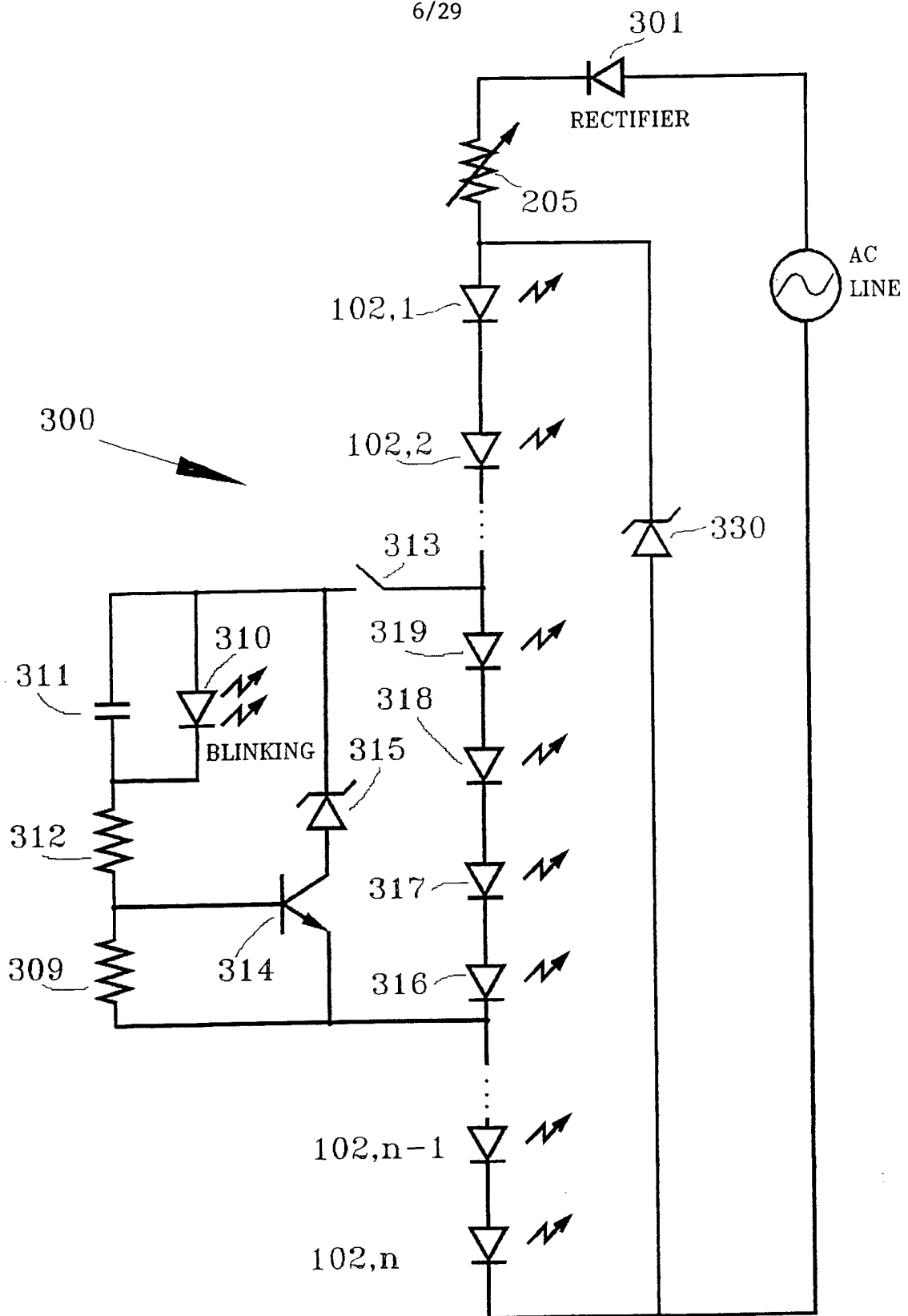

FIG. 3

7/29

NP DISCHARGE CHARACTERISTIC CURVES AT 25°C (77°F)

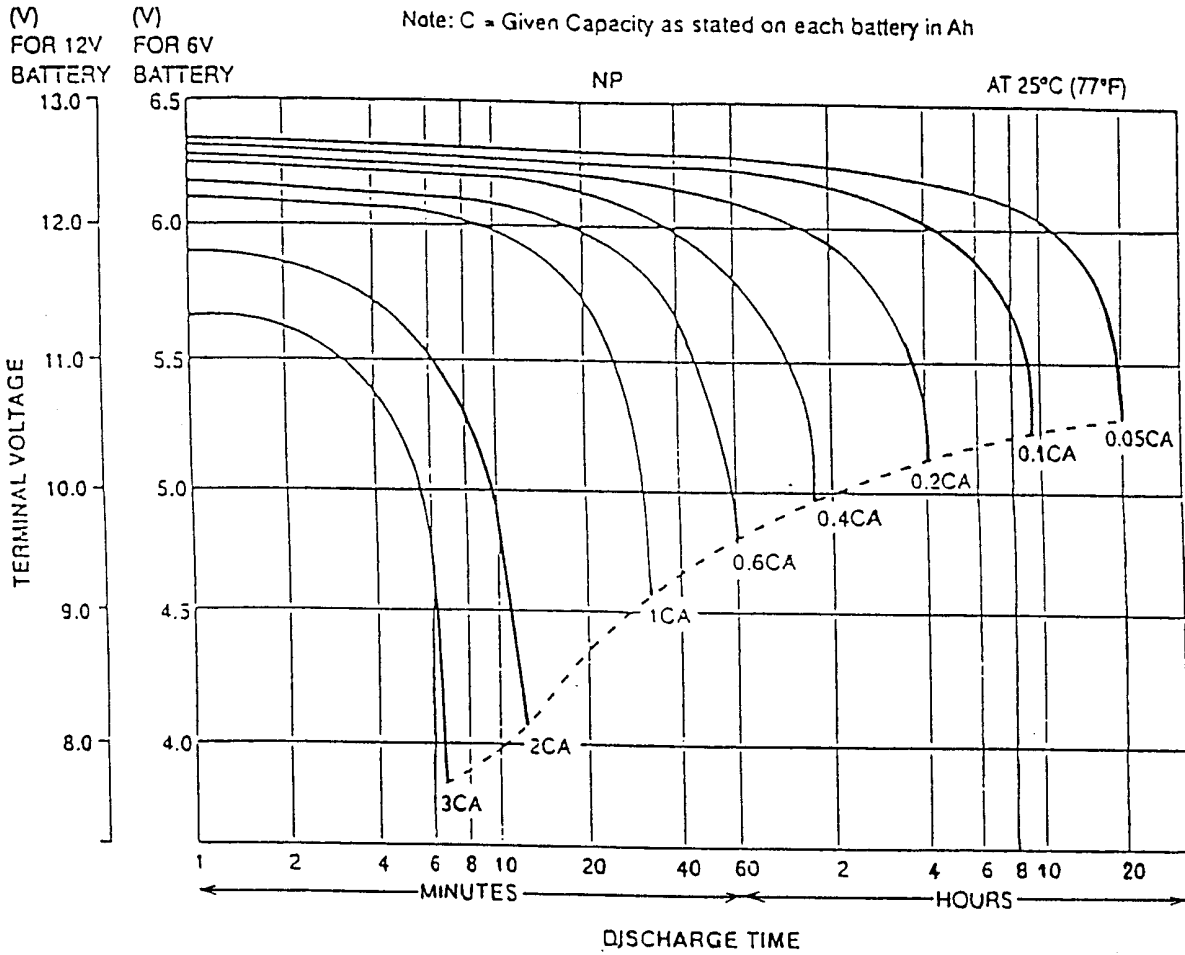

FIG. 4A

8/29

DISCHARGE RATE	APPROX. DISCHARGE TIME	APPROX. DISCHARGE RATE TIMES DISCHARGE TIME
A	min	A* min
1	25	25
0.6	45	27
0.4	90	36
0.2	220	44
0.1	540	54
0.05	1200	60

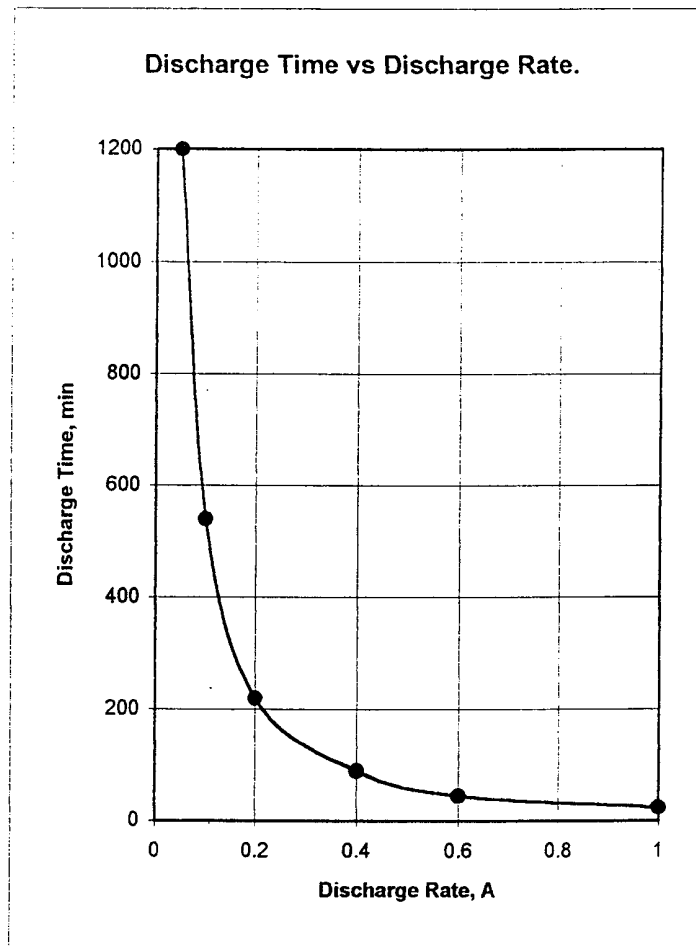

FIG. 4B

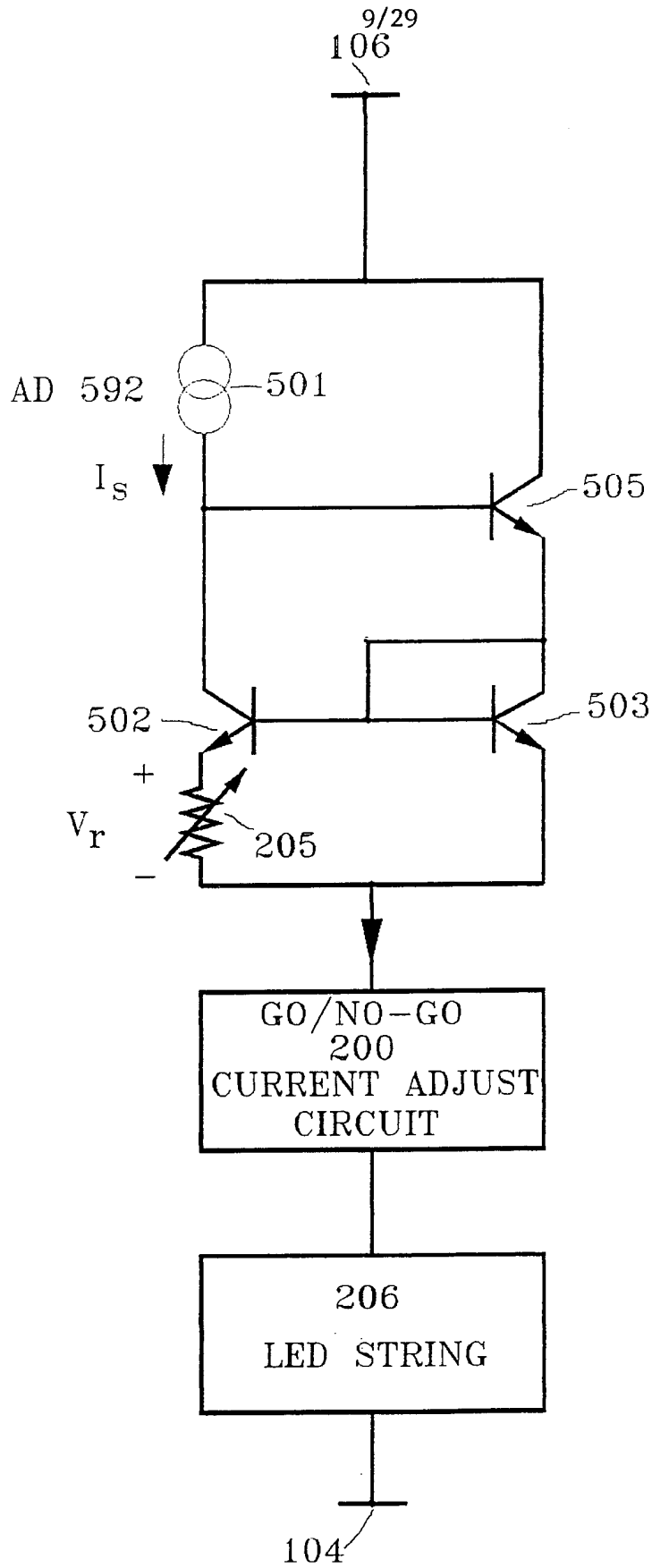

FIG. 5A

10/29

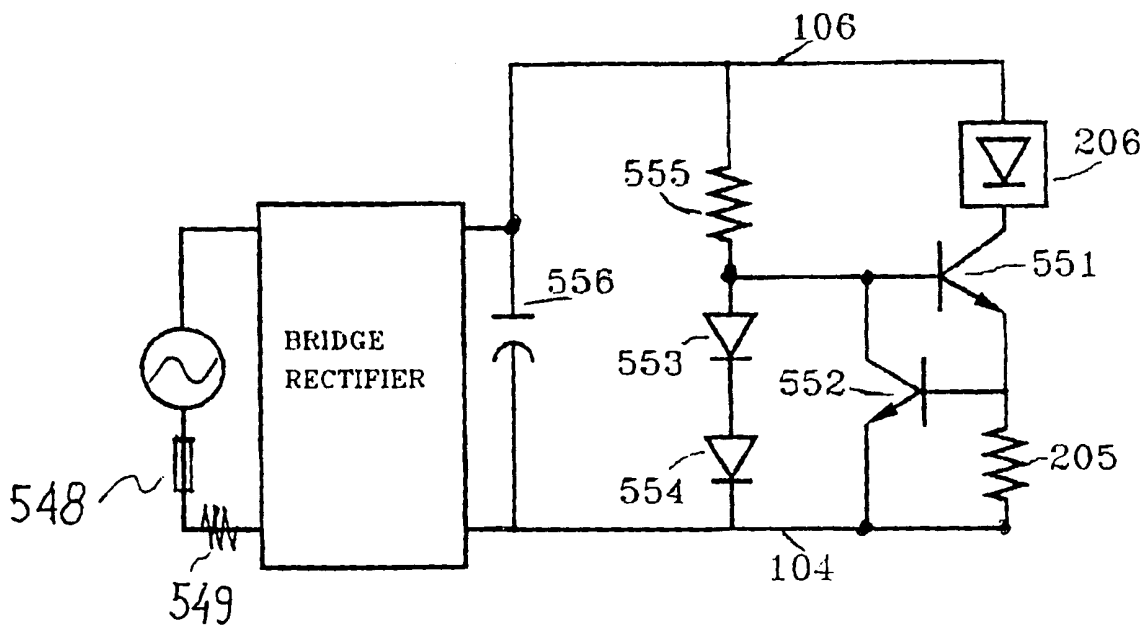

FIG. 5E

11/29

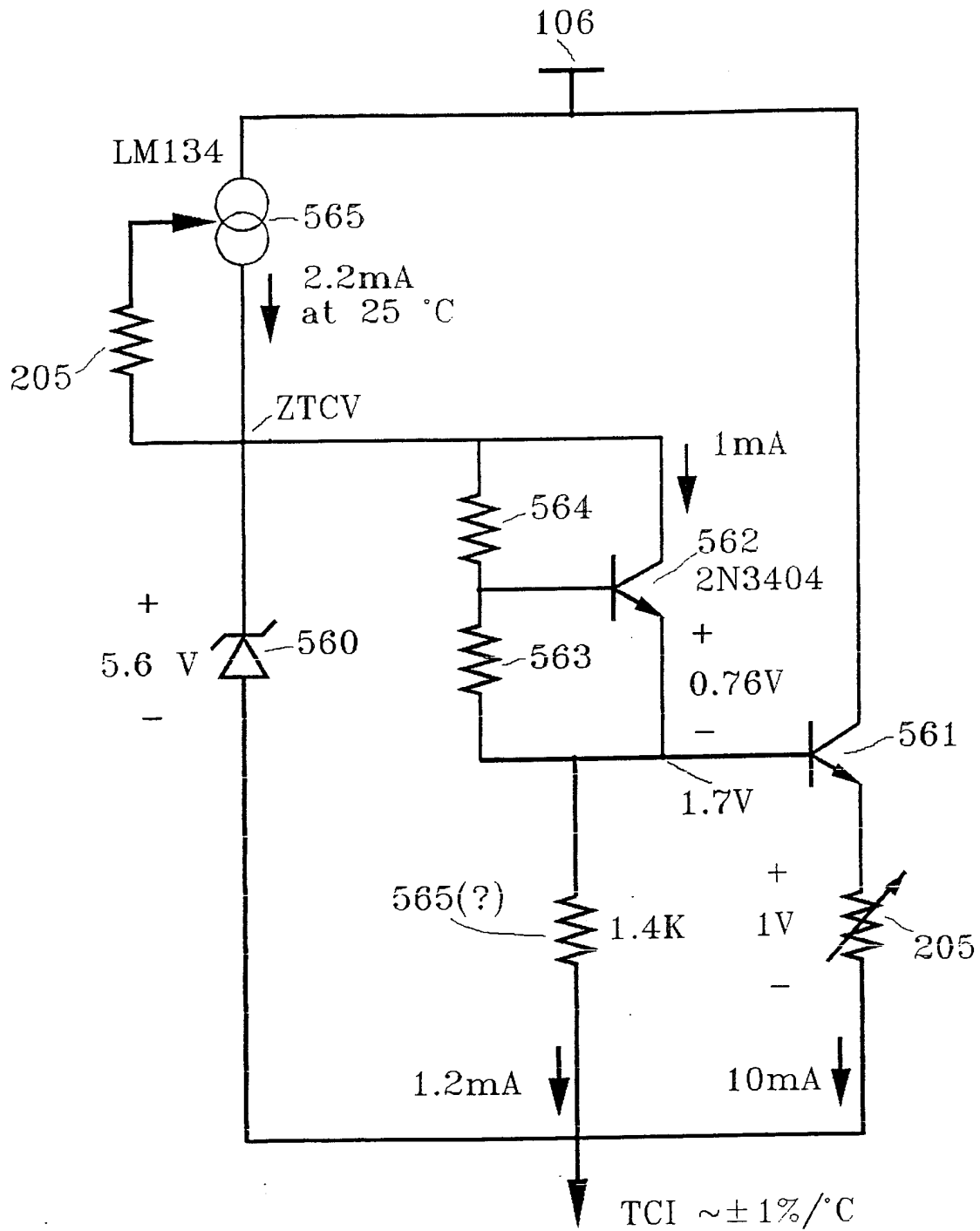

FIG. 5G

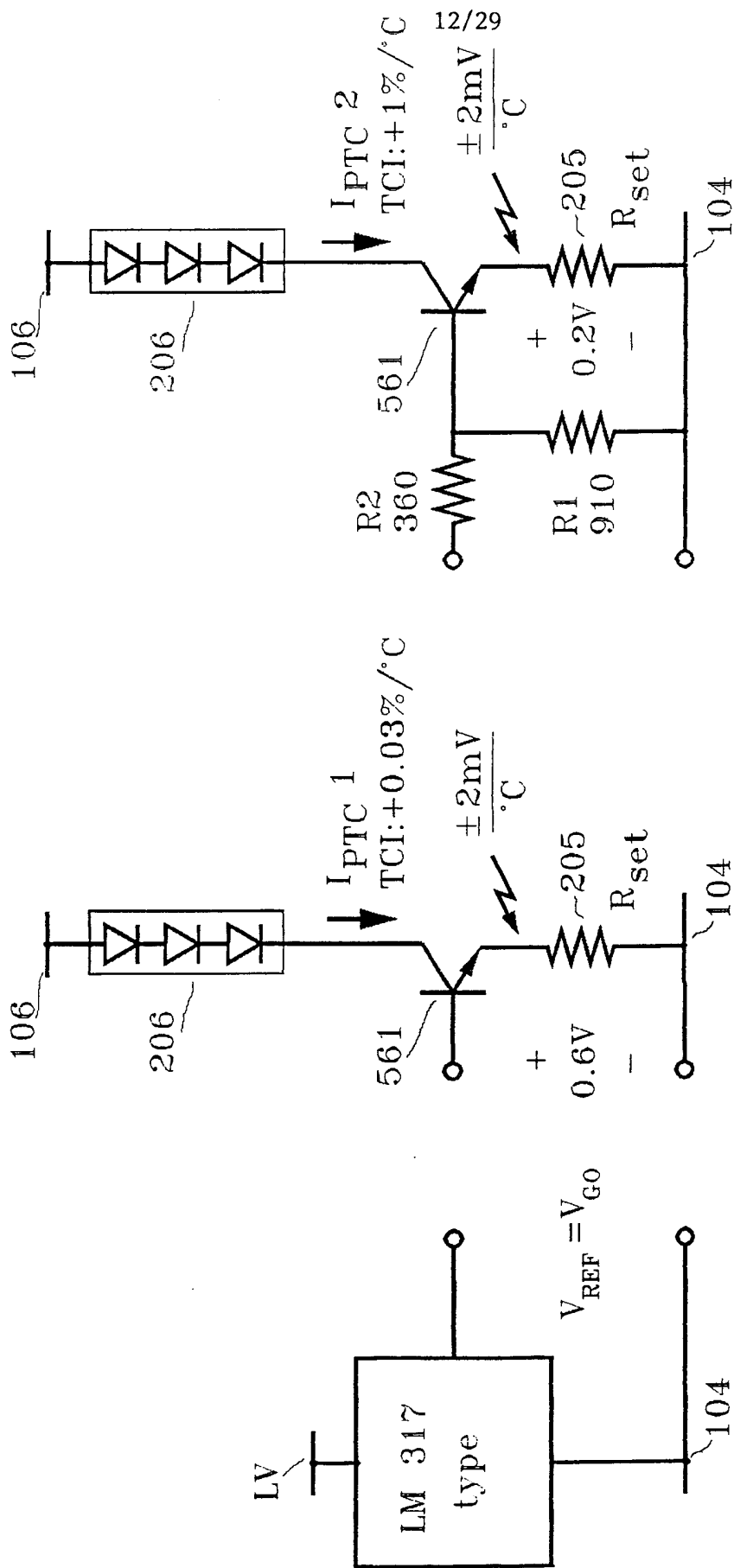

FIG. 5H

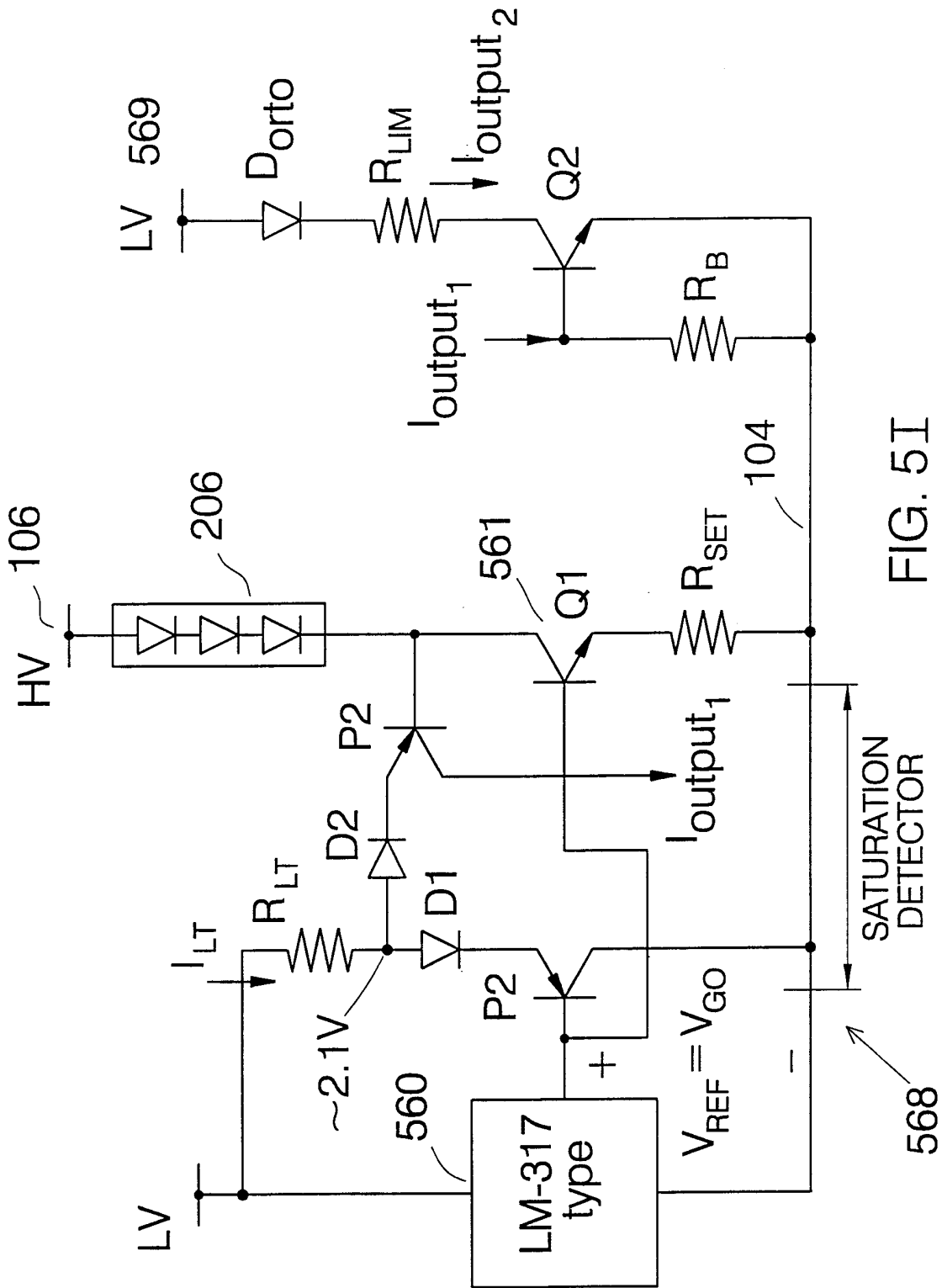
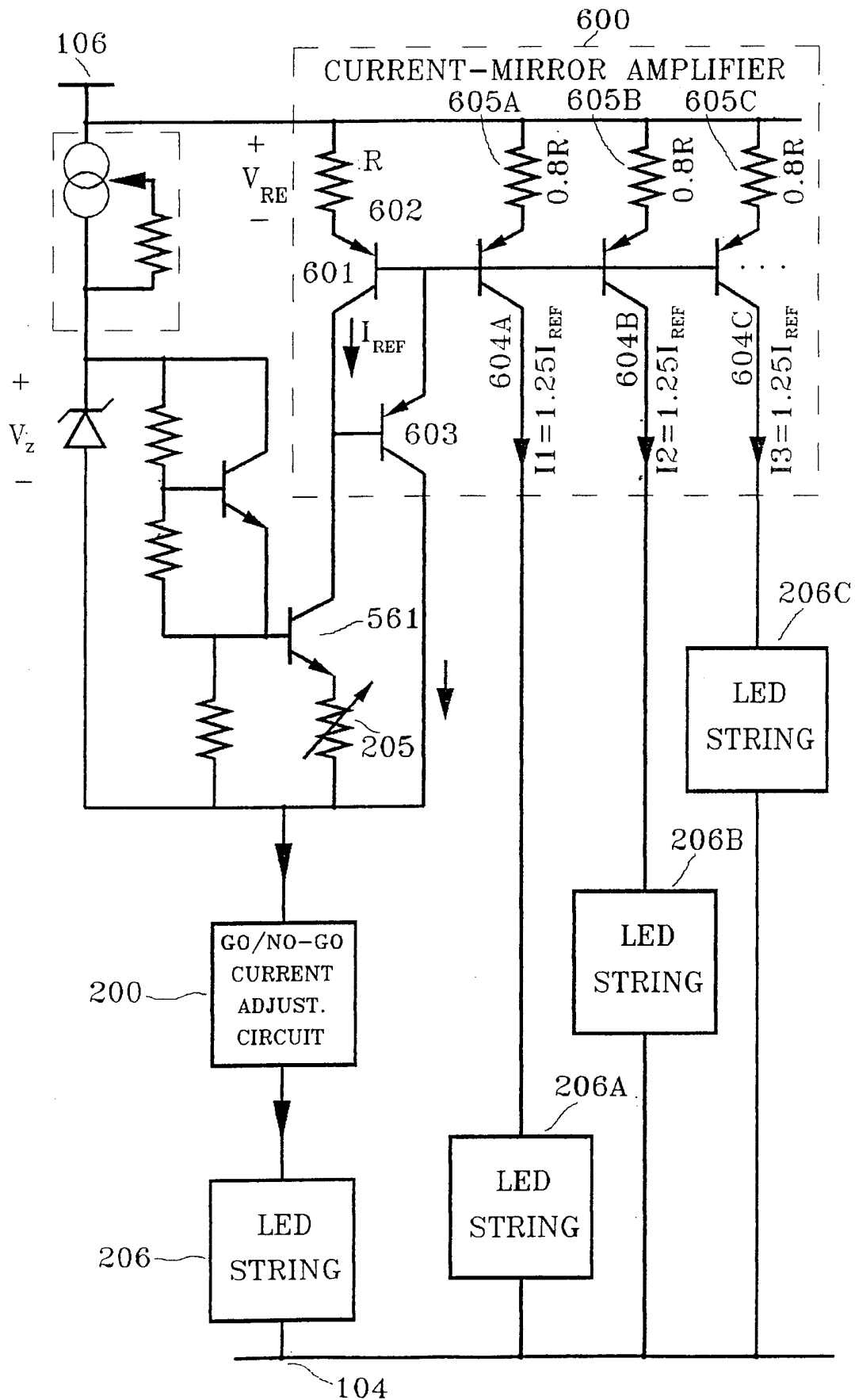

FIG. 5I

FIG. 6A



15/29

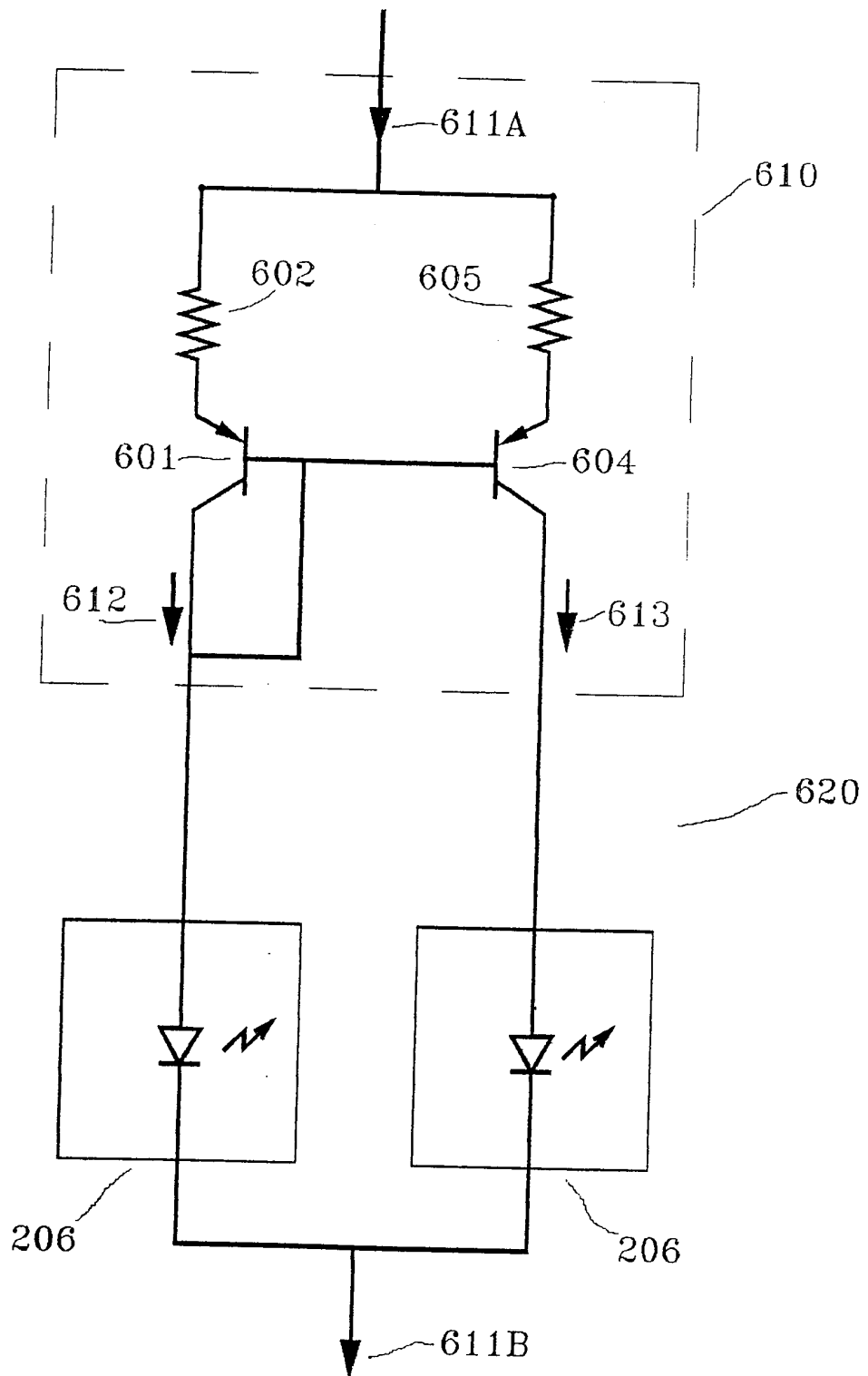

FIG. 6B

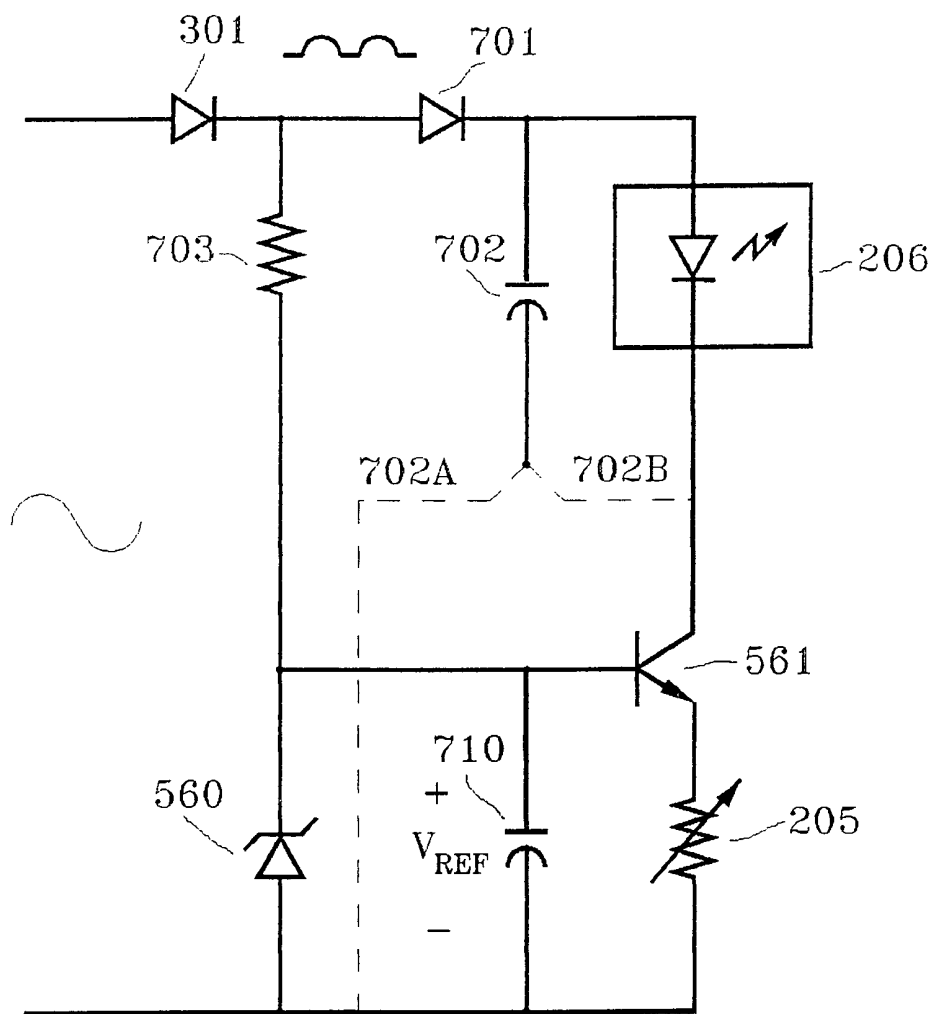

FIG. 7A

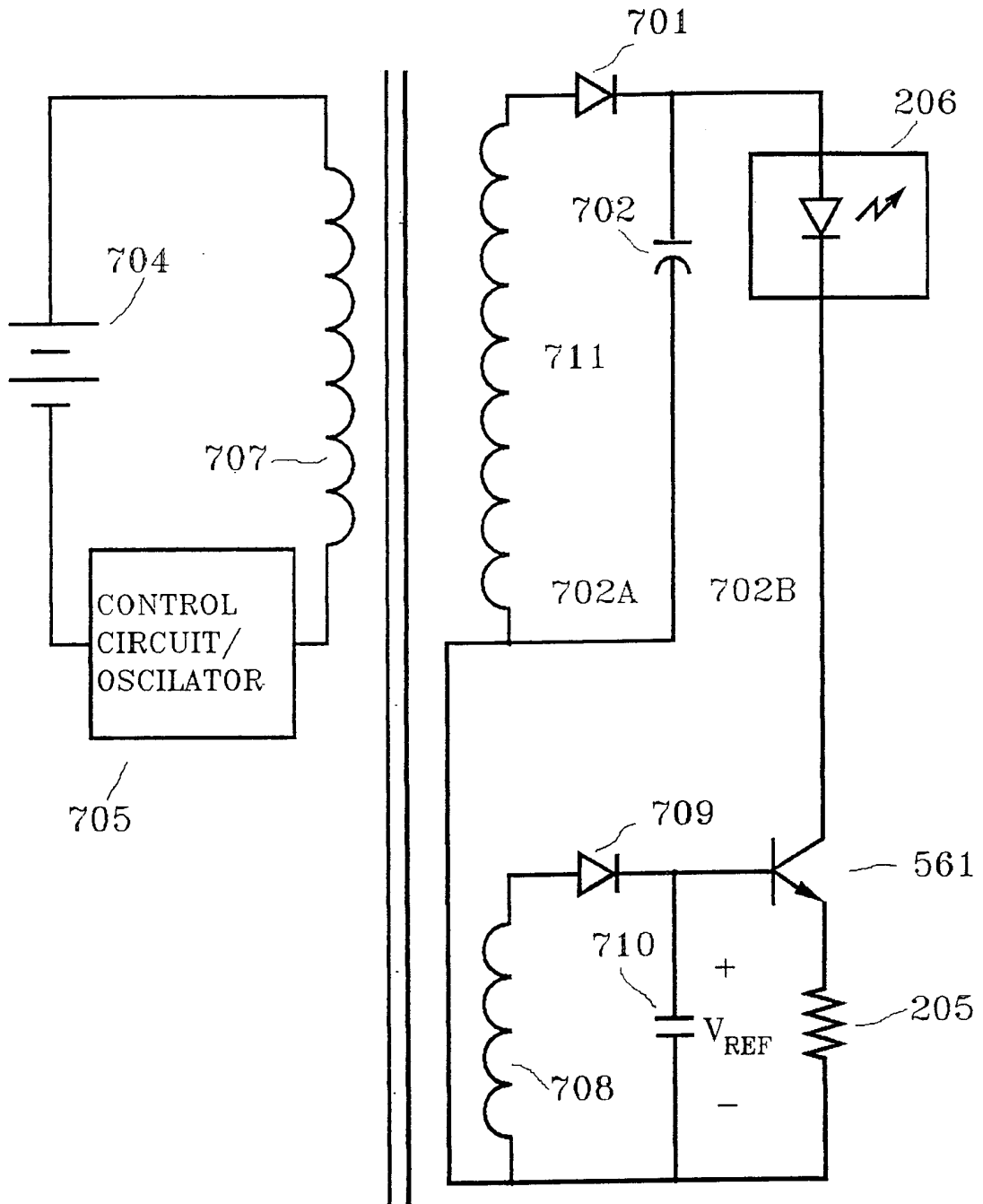
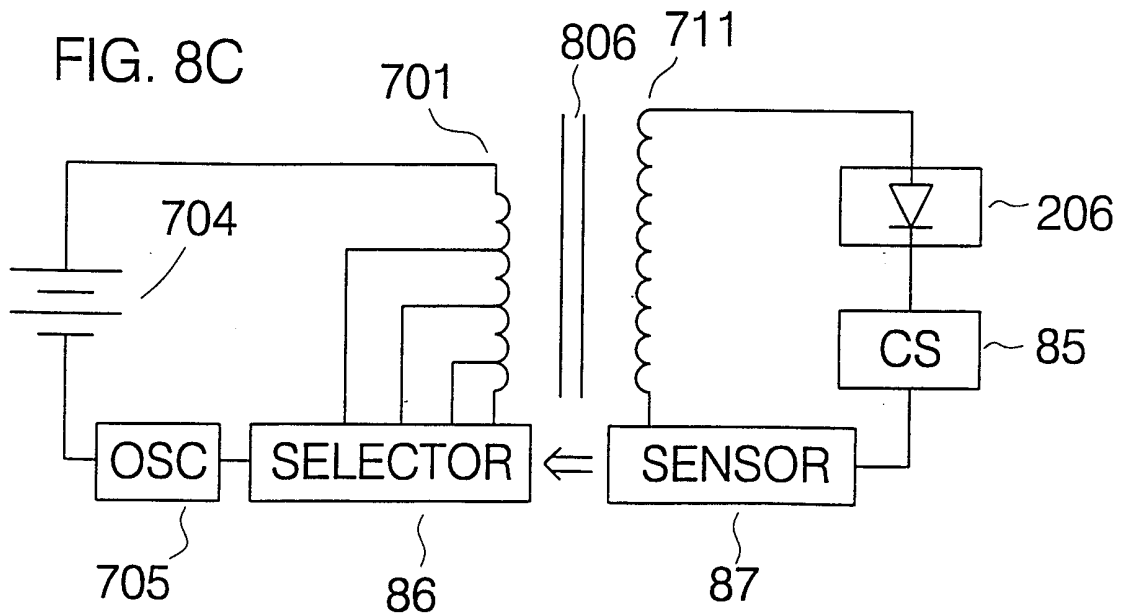
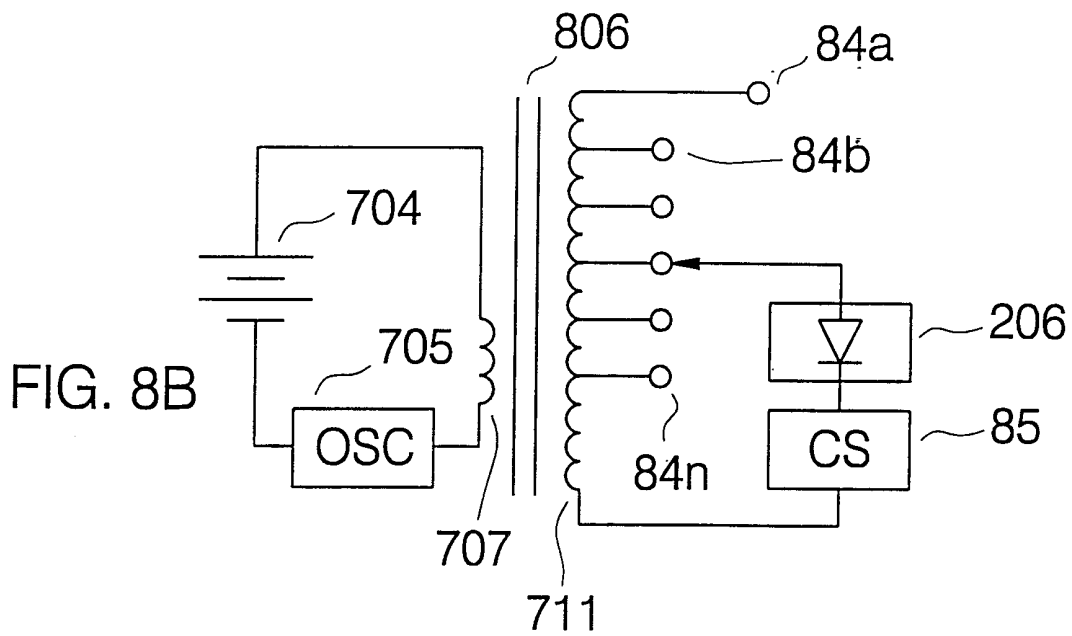
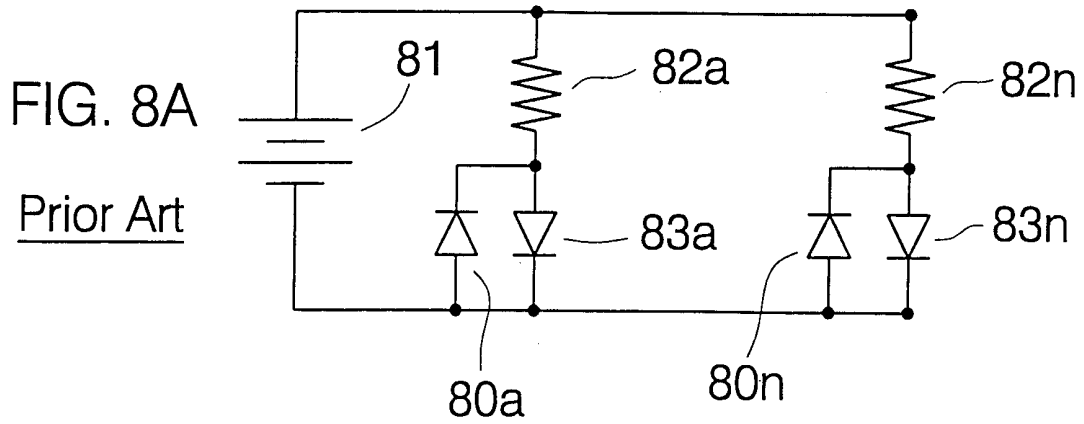

FIG. 7B



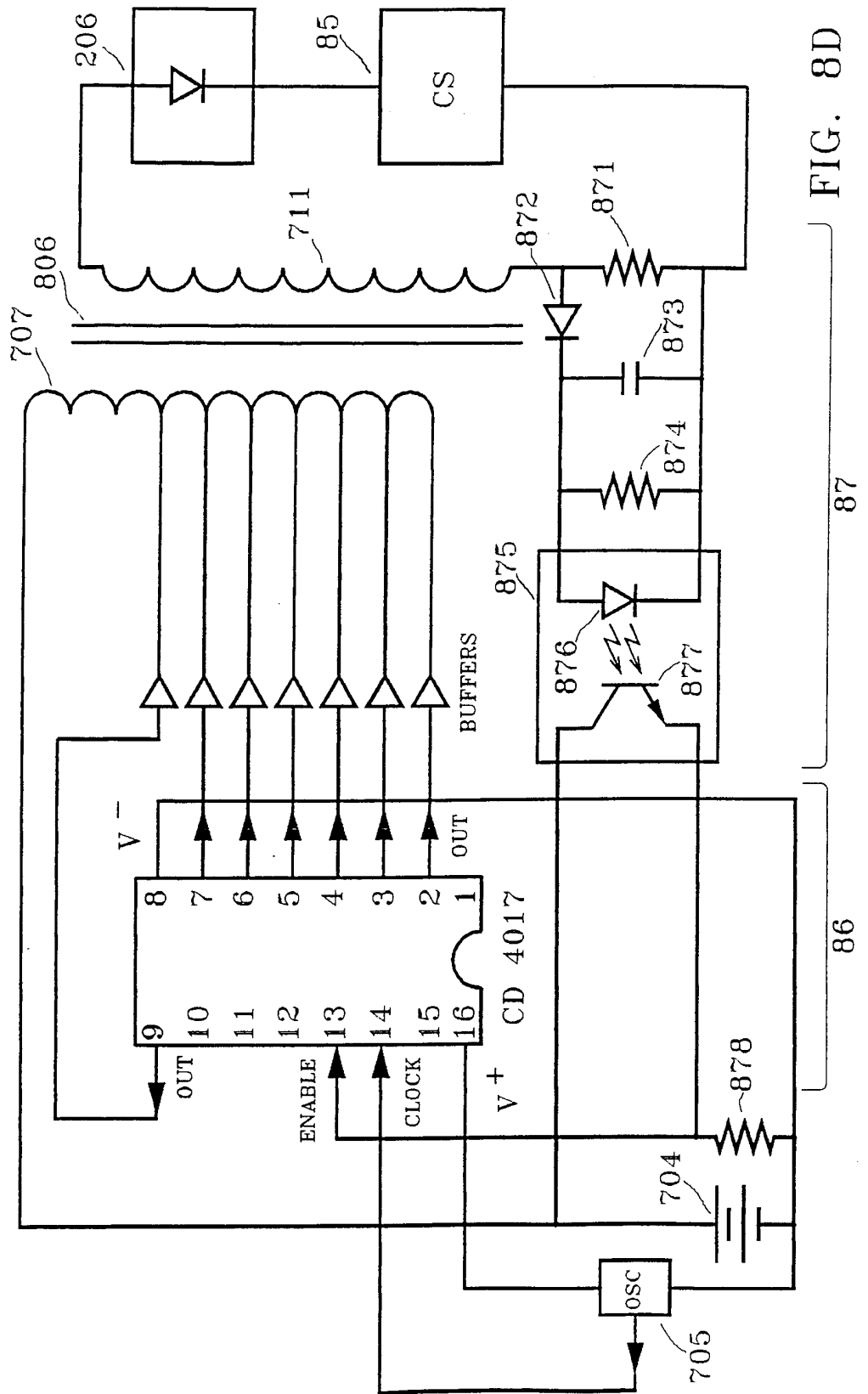

FIG. 8D

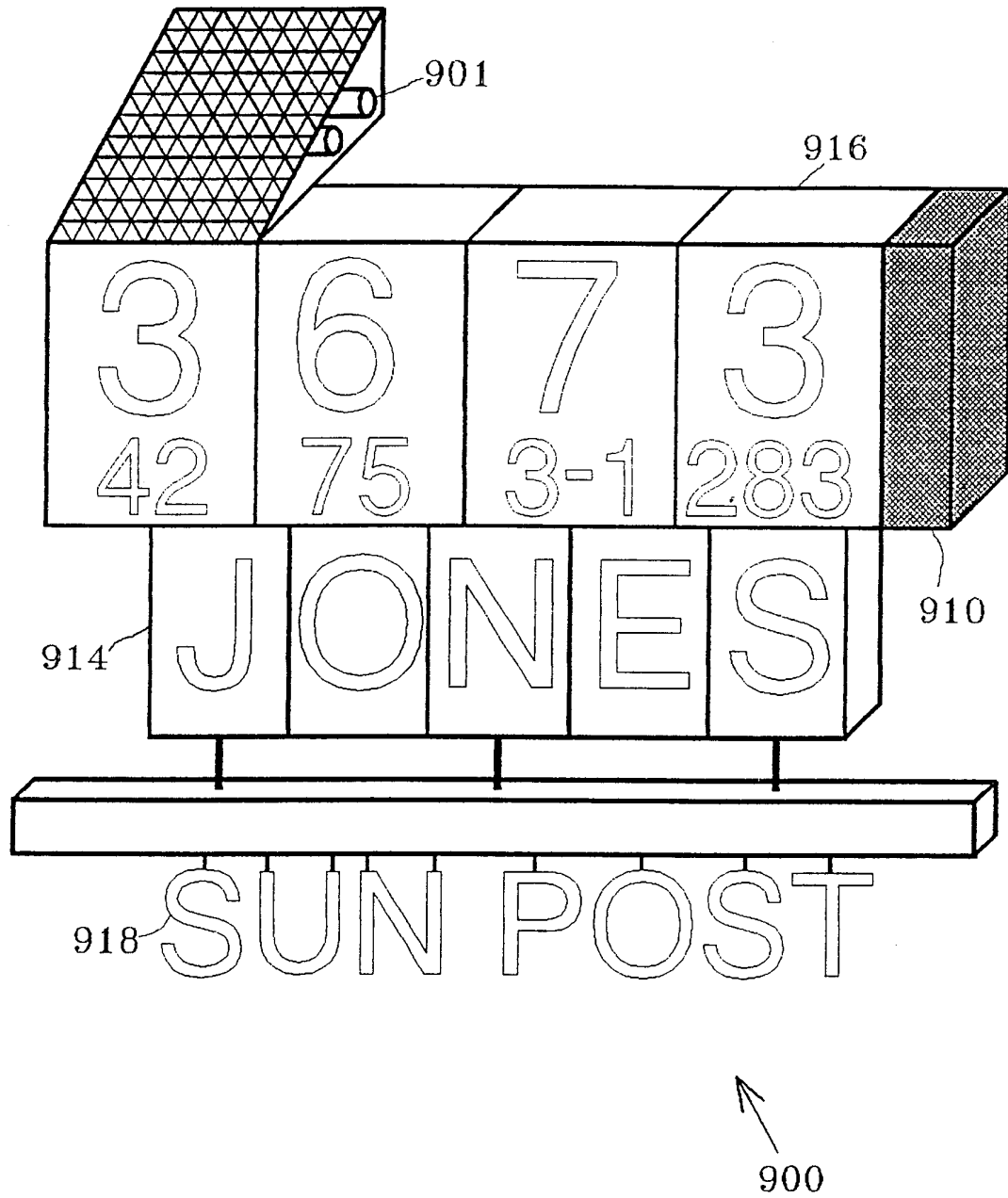

FIG. 9A

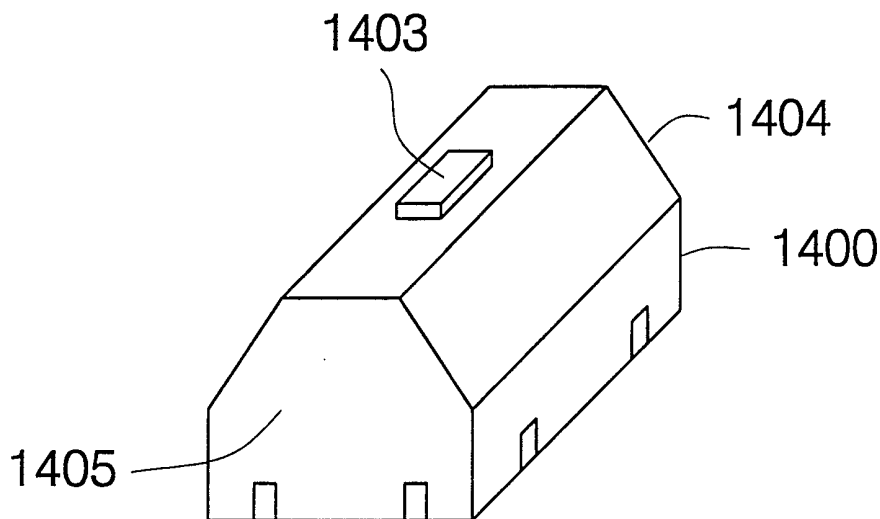
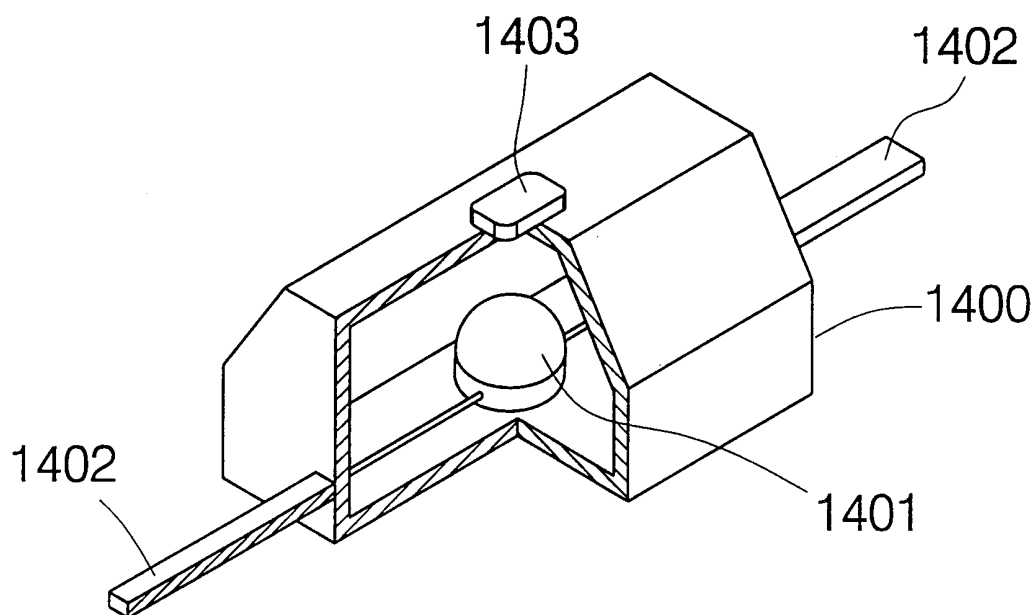

FIG. 12

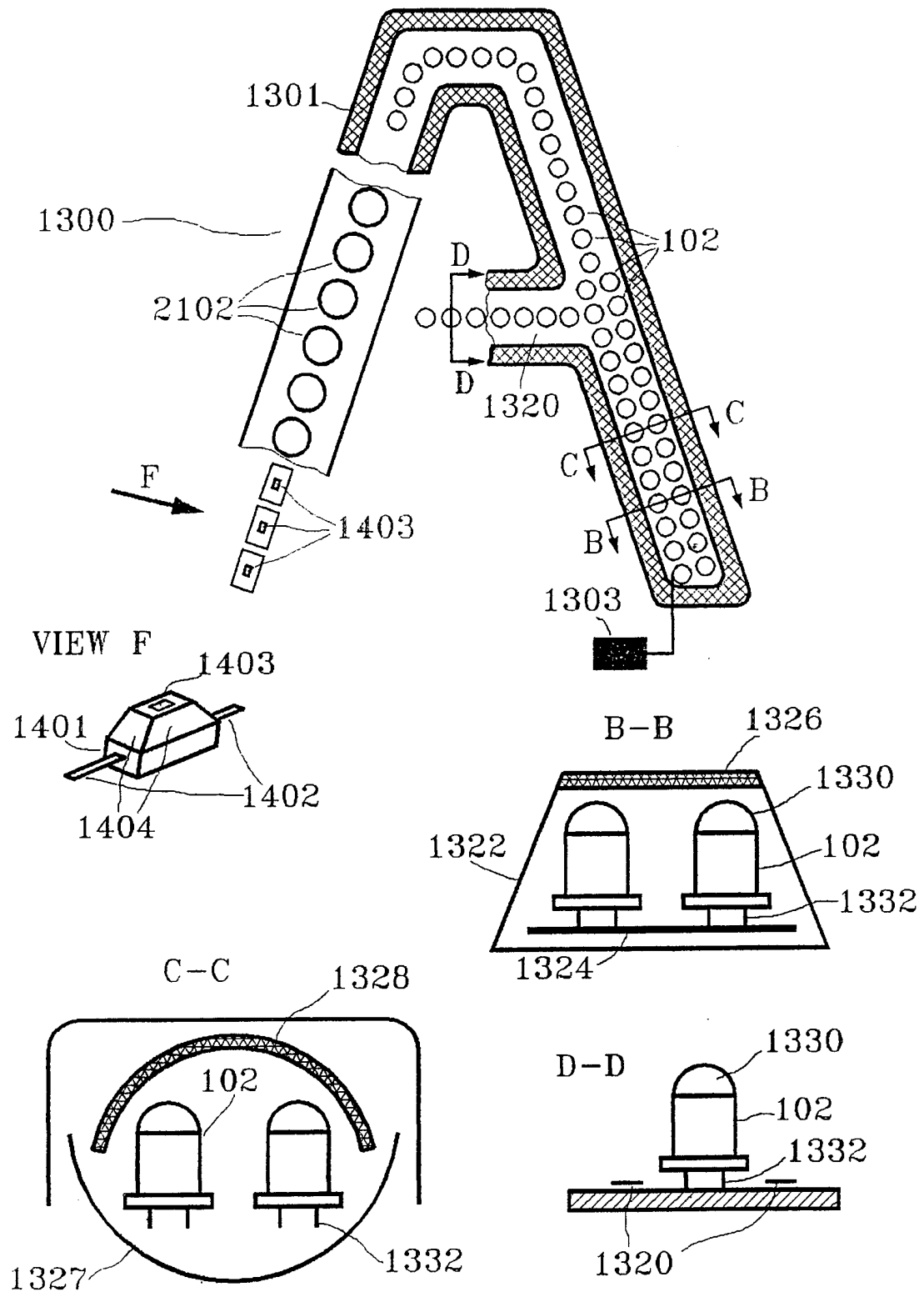
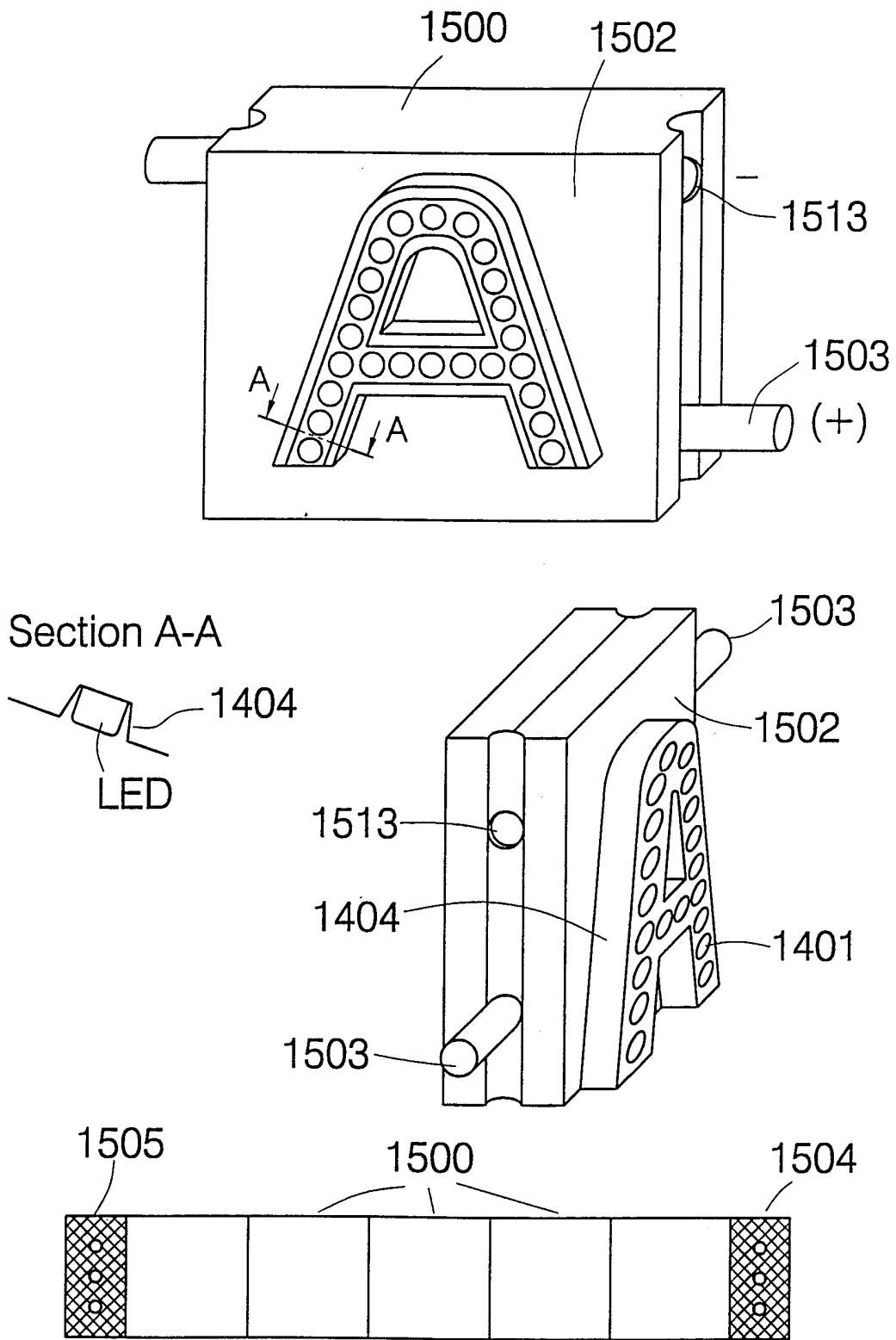
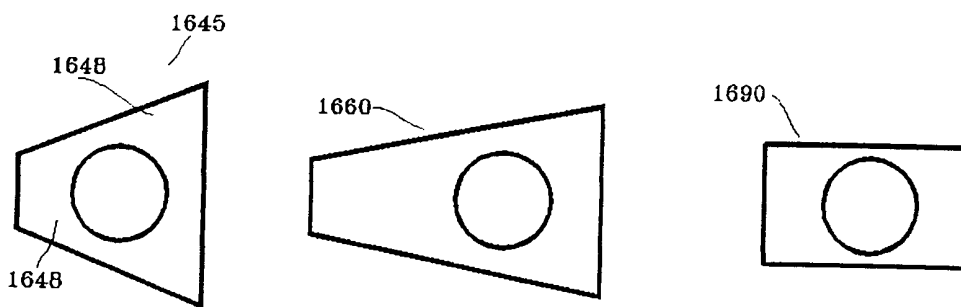
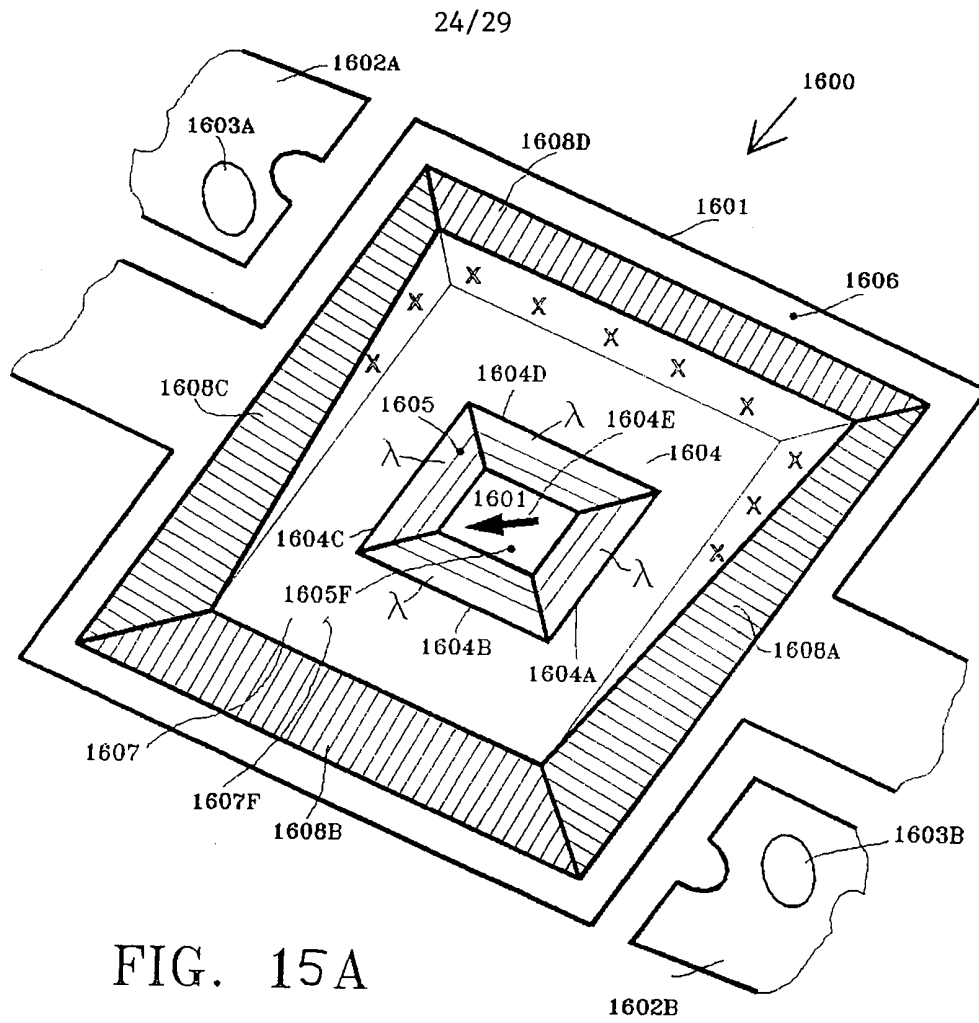

FIG. 13



1550 **FIG. 14**



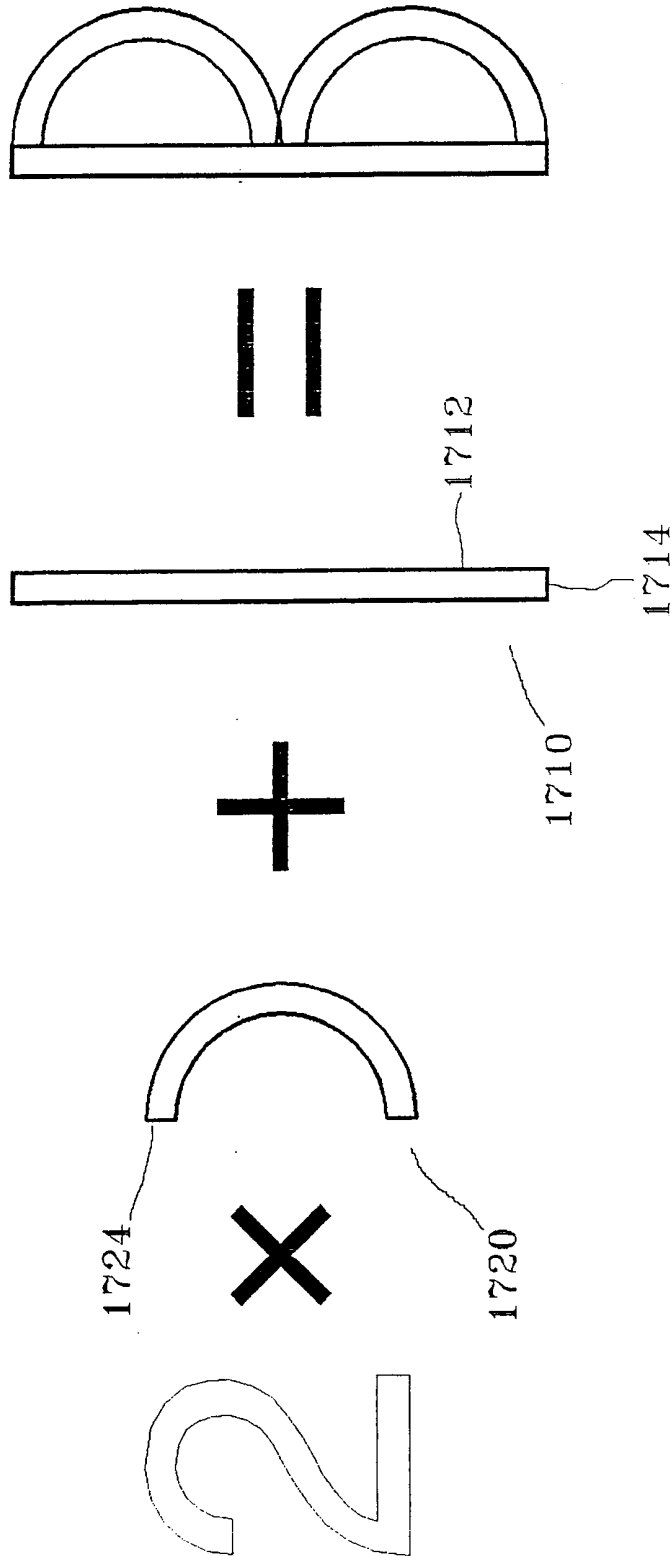

FIG. 16

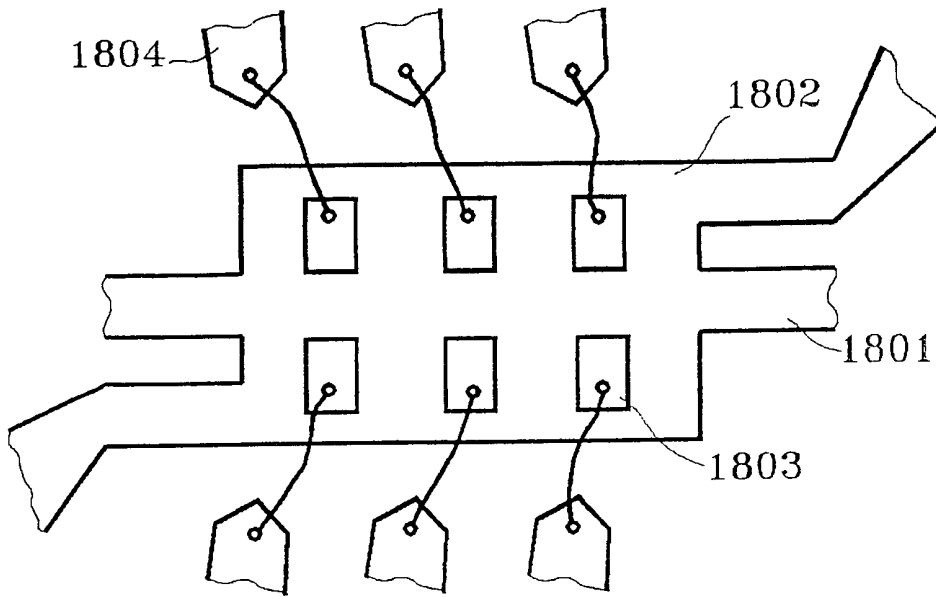

FIG. 17 A

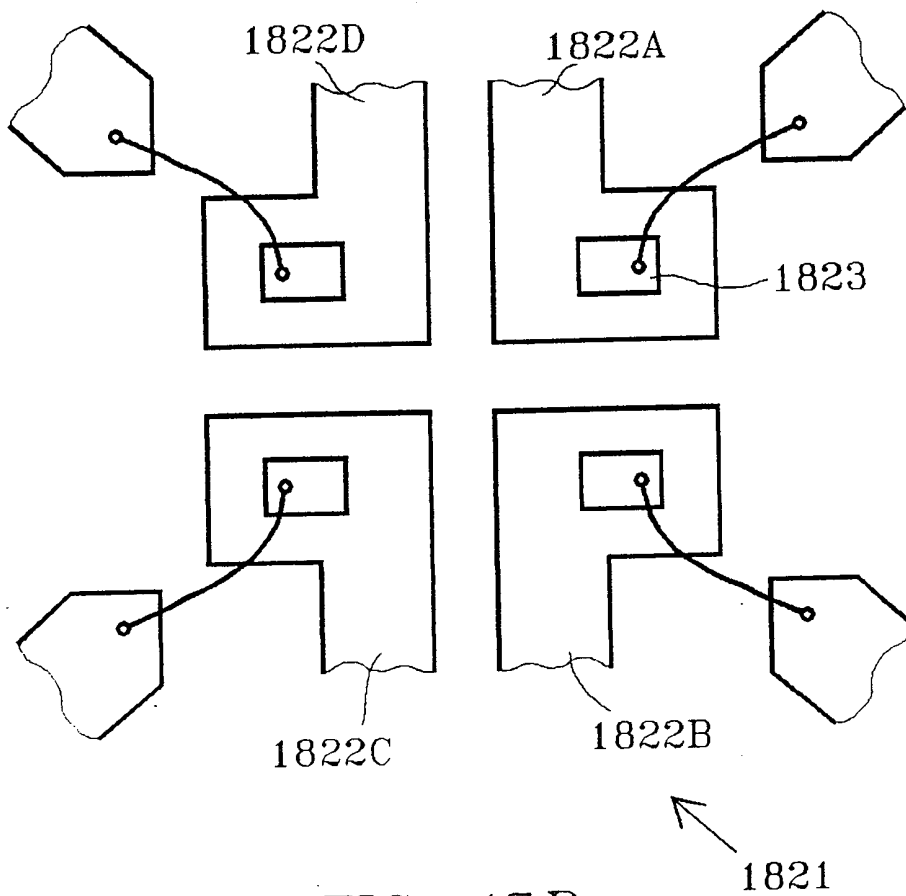

FIG. 17 B

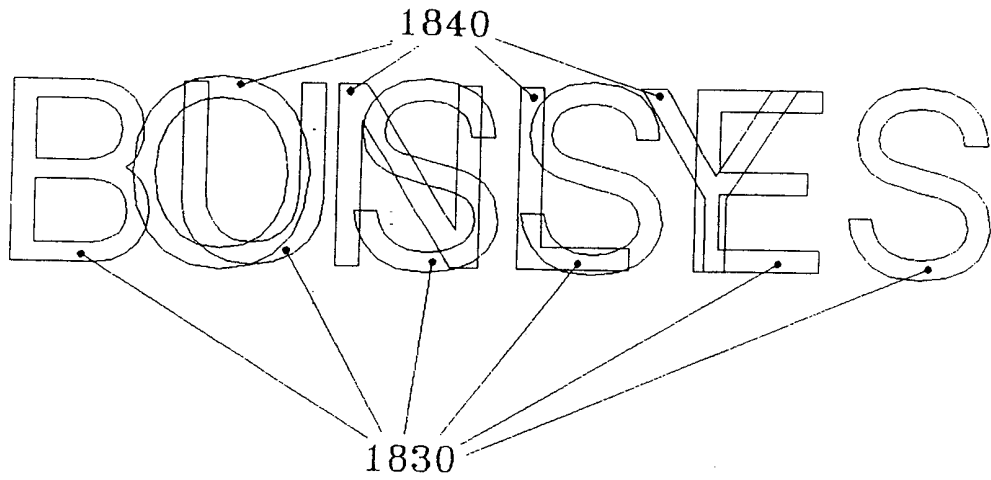

FIG. 17 C

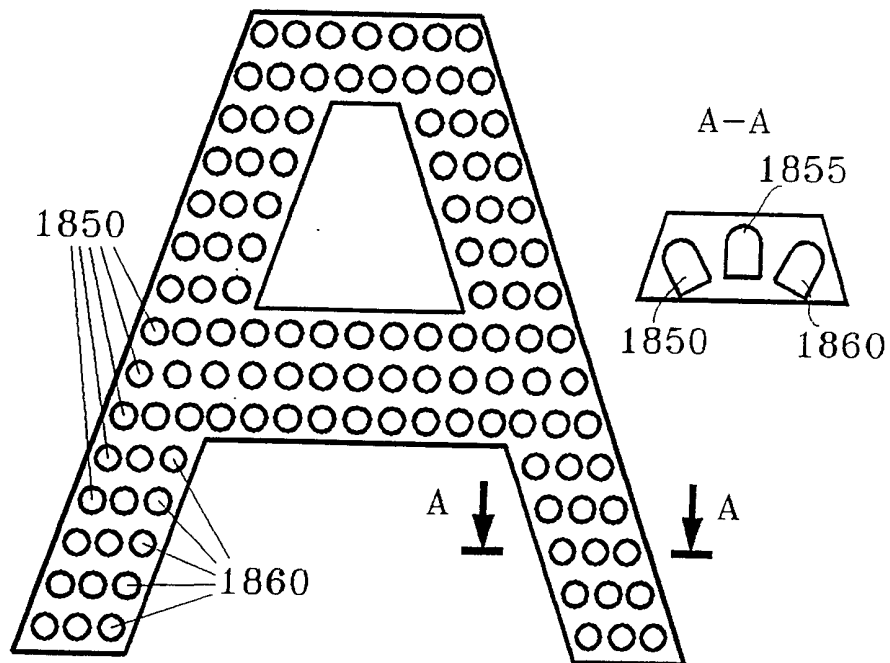

FIG. 17 D

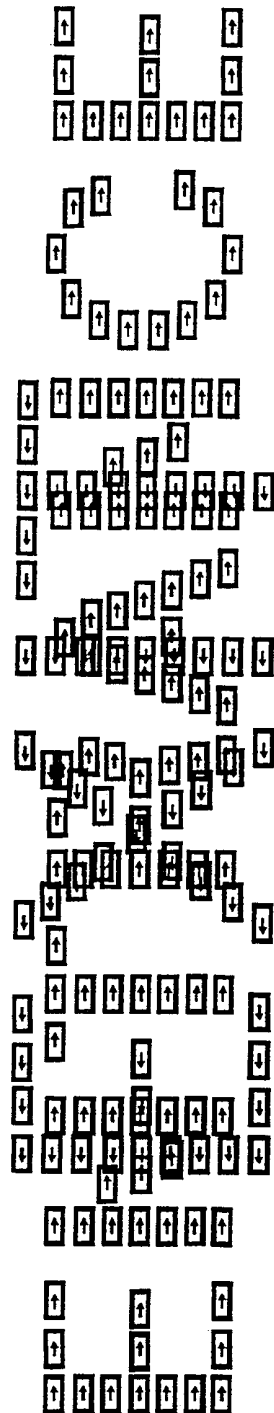

FIG. 17E

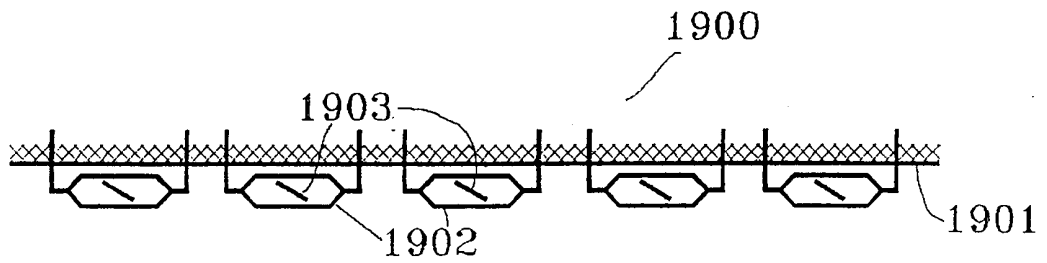

FIG. 18

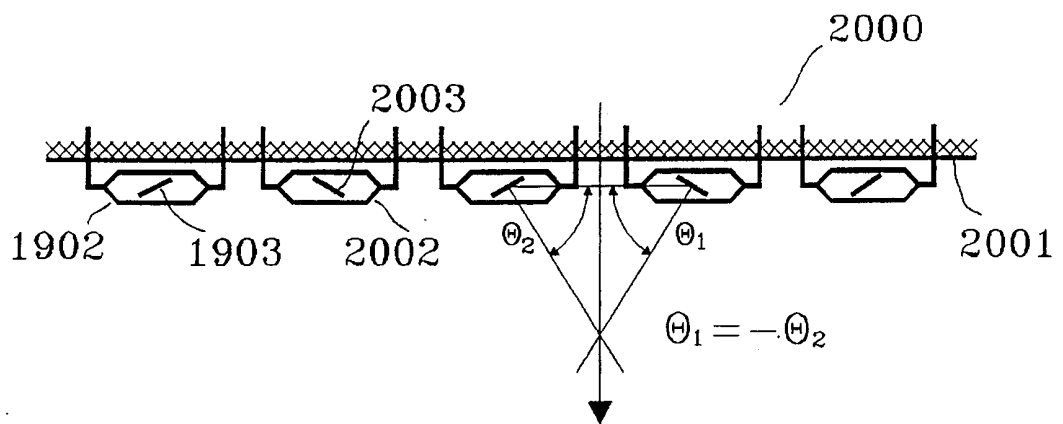

FIG. 19