

[54] **RECLOSABLE PACKAGE AND CONTROLLED RELEASE PAPER FOR USE THEREIN**

3,272,422 9/1966 Miller..... 229/48 SB

[75] Inventor: **Harmon B. Miller**, Atlanta, Ga.

Primary Examiner—William I. Price
Assistant Examiner—Stephen P. Garbe
Attorney, Agent, or Firm—Cushman, Darby & Cushman

[73] Assignee: **Reclosable Package Corp.**, Atlanta, Ga.

[22] Filed: **June 21, 1972**

[21] Appl. No.: **264,878**

[57] **ABSTRACT**

[52] U.S. Cl..... **229/62, 229/48 SB, 229/51 WB**

[51] Int. Cl..... **B65d 33/16**

[58] Field of Search..... 229/62, 66, 51 WB, 48 SB, 229/80, 51 SC; 206/DIG. 18

An improved reclosable package having a closure in which a pressure sensitive adhesive is adhered to a release sheet. The adhesion is improved by using a release sheet partly coated with a release coating in areas interspersed with uncoated areas, the uncoated areas adhering more strongly to the pressure sensitive adhesive than the coated areas.

[56] **References Cited**

UNITED STATES PATENTS

12 Claims, 32 Drawing Figures

3,217,871 11/1965 Lee..... 229/51 WB

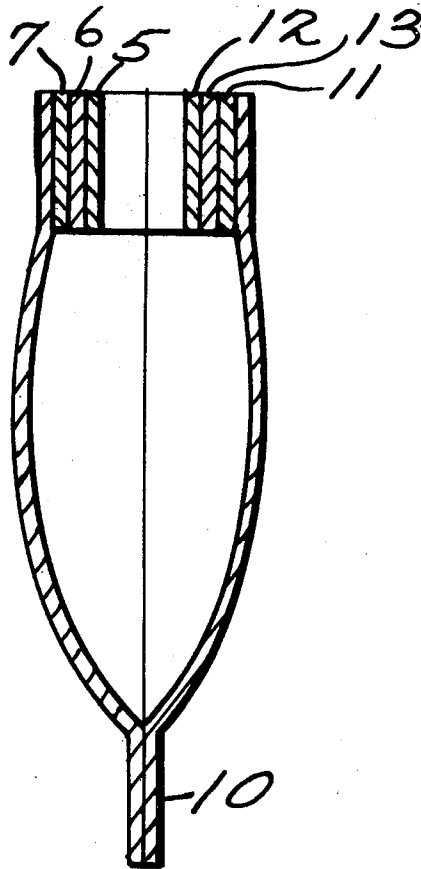

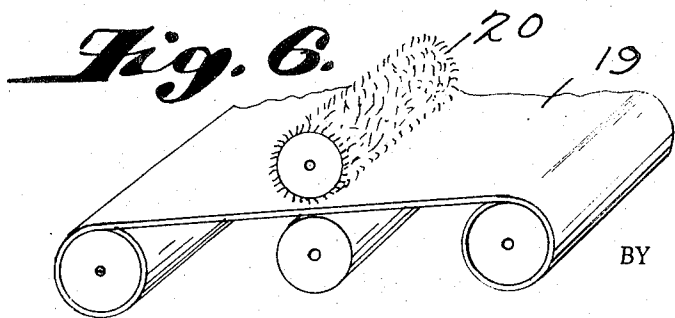
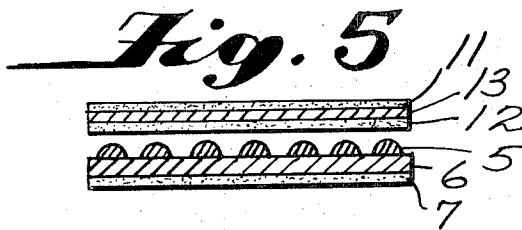
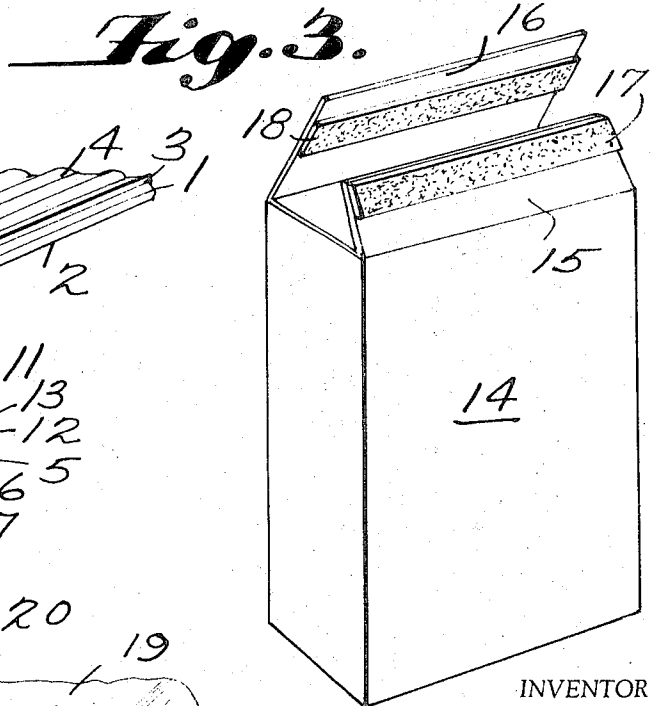
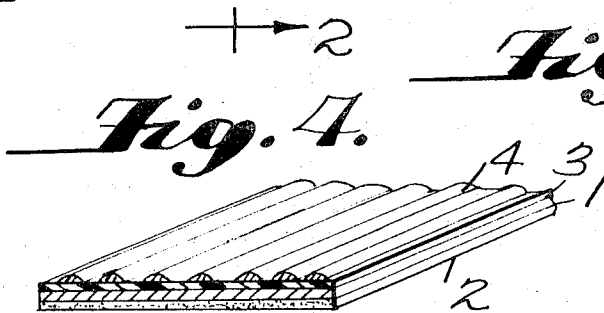
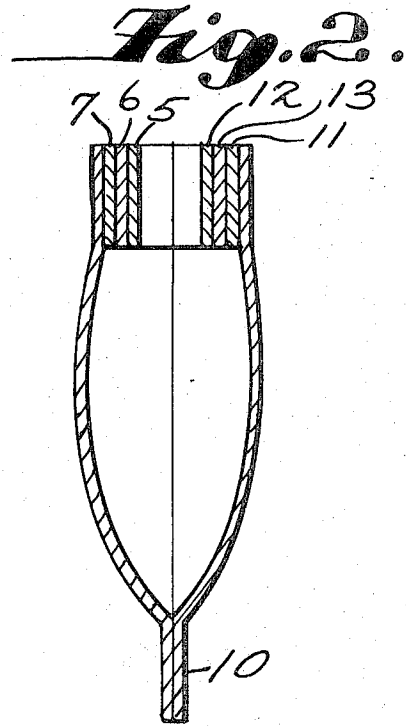
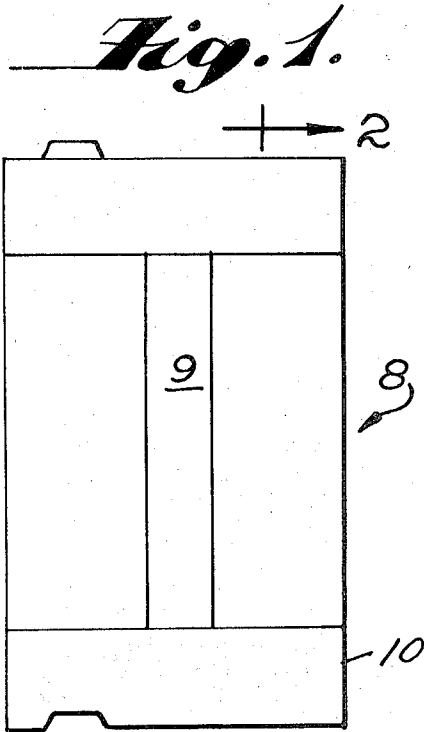

INVENTOR

HARMON B. MILLER

BY

Cushman, Daly & Cushman
ATTORNEYS

FIG. 7.

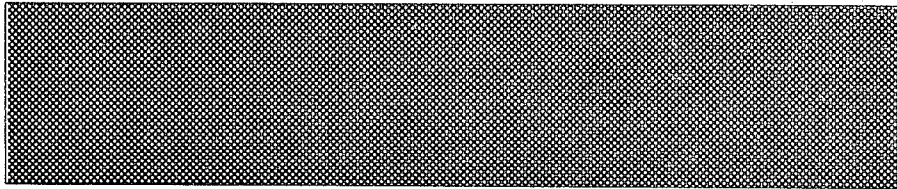

FIG. 8.

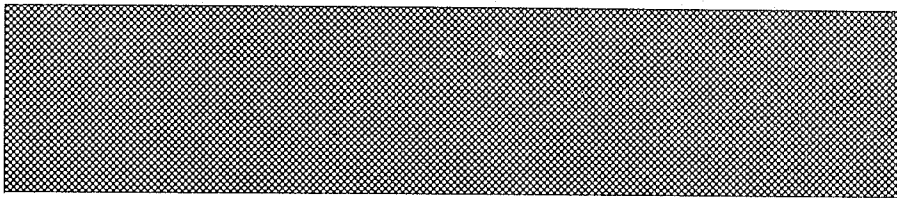

FIG. 9.

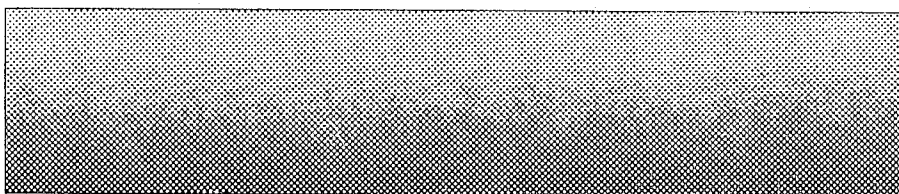

FIG. 10.

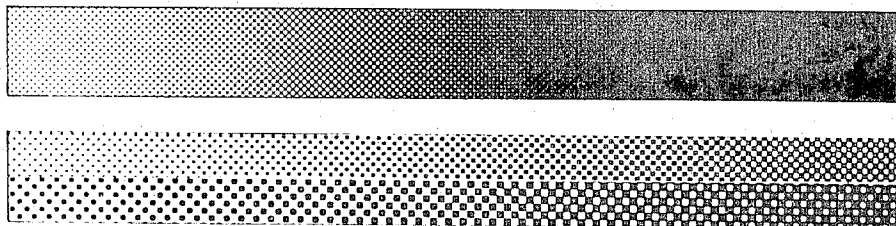

FIG. 11.

INVENTOR.
HARMON B. MILLER
BY
Cushman, Dady, Cushman
ATTORNEYS

FIG. 12.

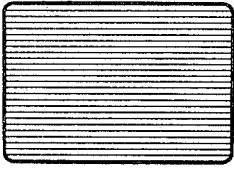

FIG. 13.

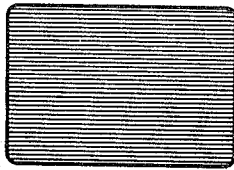

FIG. 14.

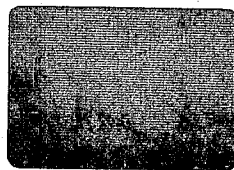

FIG. 15.

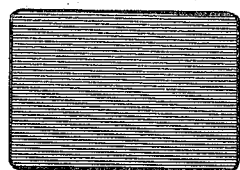

FIG. 16.

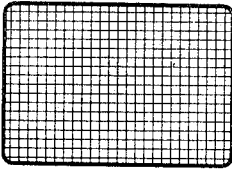

FIG. 17.

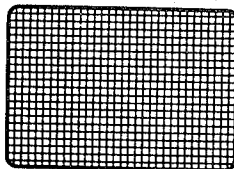

FIG. 18.

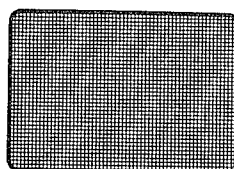

FIG. 19.

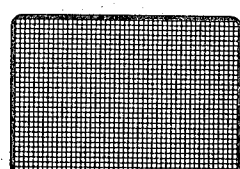

FIG. 20.

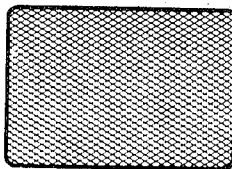

FIG. 21.

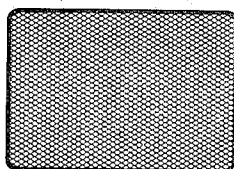

FIG. 22.

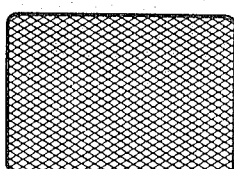

FIG. 23.

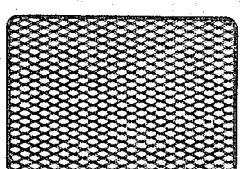

FIG. 24.

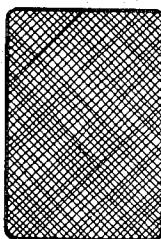

FIG. 25.

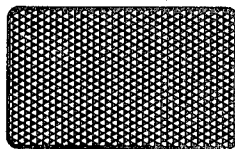
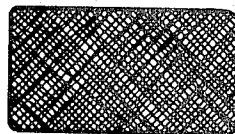

FIG. 28.

FIG. 26.

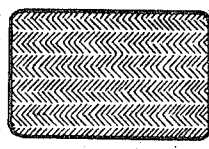
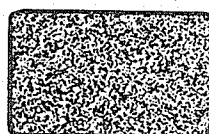

FIG. 29.

FIG. 27.

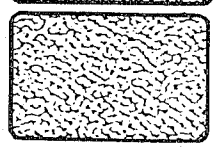
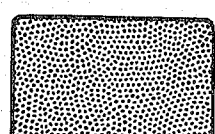

FIG. 30.

INVENTOR
HARMON B. MILLER
BY
Cushman, Doherty & Lushman
ATTORNEYS

Fig. 30.

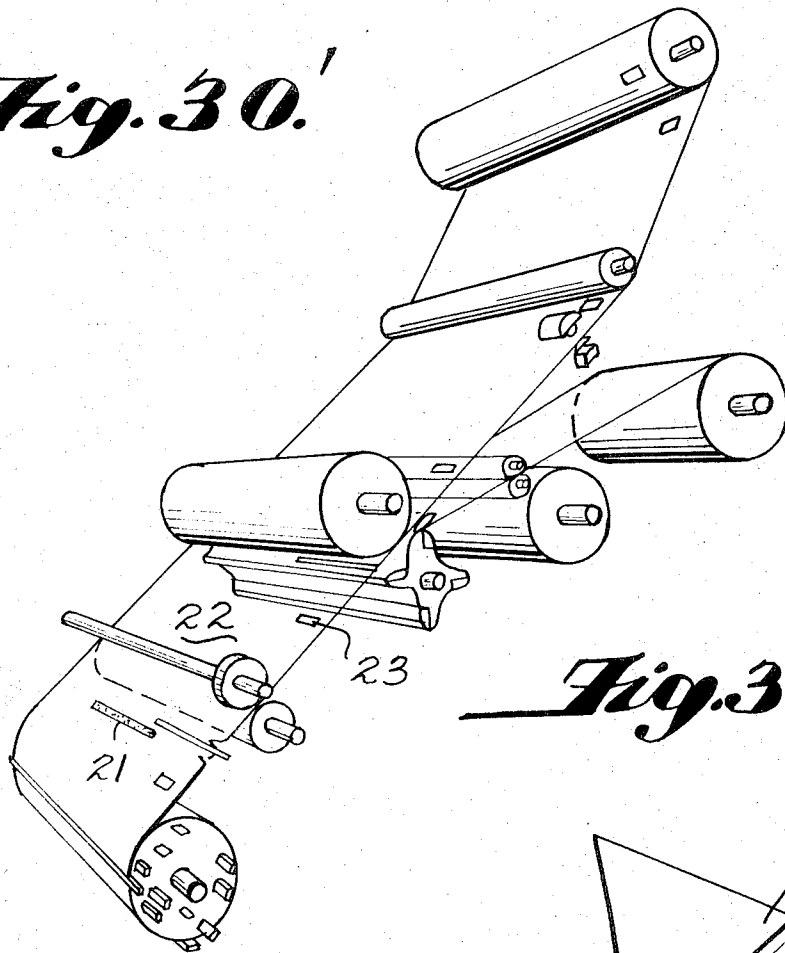
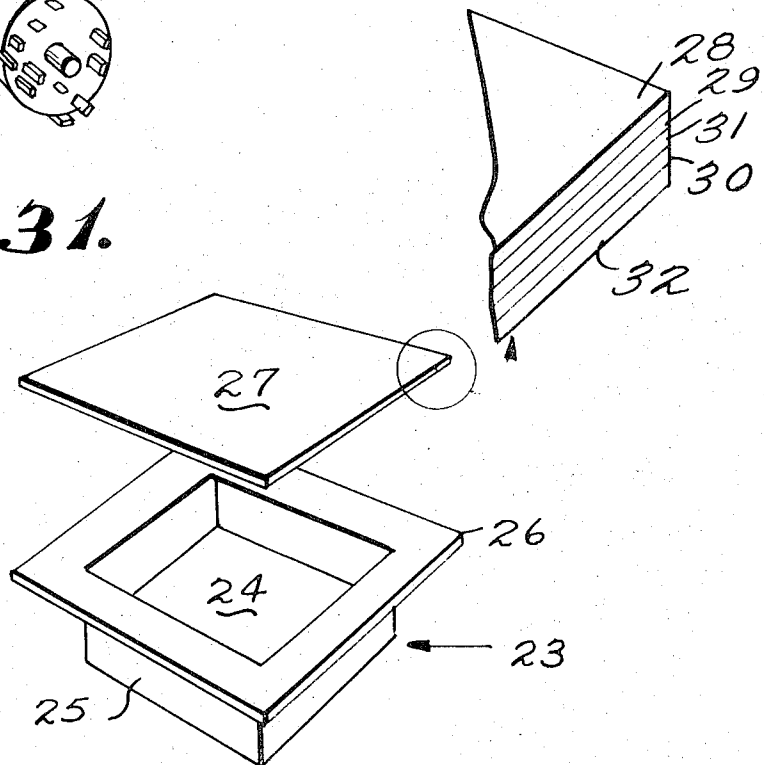

Fig. 32.

Fig. 31.



RECLOSABLE PACKAGE AND CONTROLLED RELEASE PAPER FOR USE THEREIN

The present invention relates to an improved release paper for pressure sensitive adhesive which is characterized by an improved ability to adhere to pressure sensitive adhesive.

A pressure sensitive adhesive is an adhesive which is permanently tacky at room temperature. It has the ability to stick to almost all surfaces which it contacts. It generally can be removed from smooth, non-fibrous surfaces without delamination, i.e., without a part of the adhesive being left behind. When adhered to fibrous surfaces, e.g., newsprint and similar uncoated coarse grades of paper, pressure sensitive adhesives have the characteristic of lifting some of the surface fibers when it is removed from the surface.

Pressure sensitive adhesives are used frequently as coatings on the surfaces of articles, for example, transparent cellophane tape, wall coverings and the like. In some cases, the coated article is furnished in roll form, laminated to a backing material known as release paper. The latter usually is coated with a material to which the pressure sensitive adhesive does not adhere strongly. The release paper sticks loosely to the pressure sensitive adhesive and is removed easily. However, it functions as a temporary cover for the adhesive so that it does not stick prematurely to other articles with which it comes in contact.

In U.S. Pat. No. 3,272,422, there is described a package closure which makes use of a pressure sensitive adhesive and a release paper. The pressure sensitive adhesive is coated onto a cover the shape of which is selected so that it will fit over the mouth of a receptacle. The cover is laminated to one side of a release paper, i.e., to the side which is coated with a release coating. The other side of the release paper is coated with a heat seal adhesive, i.e., an adhesive which becomes tacky only when heated. A package is sealed by placing the closure over a receptacle and sealing the heat seal adhesive to the perimeter of the mouth of the receptacle, to form a permanent bond. When the closure is lifted from the receptacle, the release paper remains behind because the heat seal adhesive has permanently bonded it to the receptacle. The pressure sensitive adhesive lifts off with the closure. After part of the contents are removed, the receptacle can be reclosed by readhering the pressure sensitive adhesive to the release paper.

U.S. Pat. Nos. 3,608,707 and 3,613,874 disclose a laminate comprised of pressure sensitive adhesive tape and release paper wherein the outer surfaces of the release paper and the tape each is coated with a heat seal adhesive. The tape is designed to be inserted into the mouth of a receptacle, for example a flexible bag, to be adhered to facing closure members. The package is opened by separating the closure member which thereby is adhered to the release paper from the facing closure member which is adhered to the pressure sensitive adhesive tape. The package can be reclosed by pressing the release paper against the pressure sensitive adhesive.

In practice it has been found that some difficulties may arise in attempting to reseal the pressure sensitive adhesive in the above-described packages to the release papers. In particular, some samples of release paper bond only weakly to some samples of pressure sensitive adhesive when an attempt has been made to

manually reseal them, even though the initial bond, produced under manufacturing conditions, is quite strong. Therefore, a need exists for a way to make a stronger bond on resealing.

The present invention provides a release paper which bonds more strongly to pressure sensitive adhesive on resealing. Briefly, the release paper has an exposed surface which is not smooth and which has raised and depressed areas. In a preferred embodiment, the depressed areas have exposed surfaces which bond more strongly to the pressure sensitive adhesive than the raised areas. This effect can be achieved either by applying a release coating in a predetermined pattern or by applying the release coating as a smooth coating and selectively removing portions of it.

The invention will be described in detail with respect to several preferred embodiments, reference being made to the drawings, in which

FIG. 1 is a side view of a flexible bag package according to the invention;

FIG. 2 is a section along lines 2—2 of FIG. 1;

FIG. 3 is a perspective view of a carton according to the invention;

FIG. 4 is a perspective view of one form of release paper useful in the present invention;

FIG. 5 is a cross-section of another form of release paper according to the invention;

FIG. 6 is a perspective view of apparatus useful in making one form of release paper for the present invention;

FIGS. 7—30 illustrate various patterns for release coatings in accordance with the invention.

FIG. 30' shows one stage in the manufacture of a plastic film useful in making the packages of FIG. 1;

FIG. 31 shows another type of package which can utilize the present invention; and

FIG. 32 shows an enlarged view of one portion of the package of FIG. 31.

One embodiment of the invention is shown in FIG. 4. The new release sheet shown there comprises a substrate 1 which, in this embodiment, is paper coated on one surface with a heat seal adhesive 2 and on the other surface with a layer of plastic 3 to which pressure sensitive adhesive adheres with a relatively strong bond. Over the surface of the layer 3 there are applied a series of stripes 4 of a release coating material which forms a weaker bond with pressure sensitive adhesive.

FIG. 5 illustrates a similar product, but in this case the intermediate plastic layer is omitted. Stripes 5 of release coating material are applied on one side of the paper 6 and a heat seal coating 7 is applied to the other side.

FIGS. 1 and 2 show the application of the present invention to a flexible plastic pouch. The pouch is indicated generally at 8 and is a hollow tube of transparent plastic, for example Saran coated polyethylene. The tube comprises a flat sheet folded so that its longitudinal edges overlap and are heat sealed to each other along a seam 9. The tube is heat sealed to form a permanent closure 10 at its lower end. The upper end of the tube is closed by means of a tape of the type illustrated in FIG. 5.

Referring again to FIG. 5, there is shown, above the release sheet, a sheet of pressure sensitive adhesive-coated material. The sheet comprises a paper base 13 coated on one side with a heat seal adhesive layer 11 and coated on the other surface with a layer 12 of pres-

sure sensitive adhesive. While FIG. 5 shows the release sheet and the pressure sensitive adhesive sheet as separate elements, they ordinarily will be furnished by the manufacturer as a laminate in which the pressure sensitive adhesive layer 13 is adhered to the release coating 5.

FIGS. 1 and 2 show one way in which the laminate of FIG. 5 is used. The laminate is placed between the upper ends of the respective sides of a pouch and the respective sides are heat sealed to opposite sides of the laminate by adhesive layers 11 and 7. The package is opened by pulling the sheets 6 and 13 apart.

FIG. 3 shows the use of a tape of the kind shown in FIG. 5 on a carton. The carton comprises a rectangular tube and end closures formed of flaps in known manner. A laminate of the type generally shown in FIG. 5 is heat sealed between overlapping flaps 15 and 16. When the carton is opened, the pressure sensitive coated sheet 17 remains adhered to flap 15 and the release sheet 18 is adhered to flap 16. This arrangement has the advantage that the contents of the package do not have to pour past the pressure sensitive adhesive to which crumbs may cling.

The pressure sensitive adhesive used in layer 13 is of a well known type. Such adhesives have a high degree of tackiness at room temperature and consequently bond almost instantly when pressed with slight pressure against almost any surface. Pressure sensitive adhesives also have high cohesive strength so that they do not delaminate and leave a residue when lifted from smooth surfaces to which they have been adhered. Generally they contain an elastomer such as natural or synthetic rubber, to impart cohesive strength and a resin such as rosin or a terpene resin to provide tackiness. However, some polymers are known which, in a single material, have the necessary balance of properties. For further information, reference is made to the Encyclopedia of Chemical Technology, Second Edition, Volume 1, page 382, and Modern Packaging Encyclopedia, 1971, page 286.

The release material used in layer 5 also represents a well known category of materials. It is a smooth-surfaced, non-fibrous material to which the pressure sensitive layer 5 adheres but from which it may be lifted manually. Materials of this type are frequently used as a coating on the back of pressure sensitive adhesive tape which is wound into rolls. It forms a sufficiently strong bond to prevent the roll from coming apart and yet not so strong as to interfere with unwinding the roll. They also are used on release sheets commonly sold with pressure sensitive type wall coverings. Some of the materials which can be used are silicones.

The layers 7 and 11 on the outer surfaces of the laminate shown in FIG. 5 are a permanent type of adhesive. For convenience, it is preferred that they are heat-activated adhesives which are not tacky at room temperature but which become tacky when heated. They may be thermoplastic or thermosetting, both types being well known. It is important that they form a stronger bond with the facing members of a package closure than the bond between the pressure sensitive layer 12 and the portions of the release sheet to which it is bonded. This is necessary to prevent the tape being pulled from the facing member when the package is opened.

The substrate for the release coatings 4 and 5 is a material which forms a stronger bond with the pressure

sensitive adhesive than the release coating. A very useful material is paper, typically up to 15 mils thick, but preferably less than 6 mils thick. For present purposes, paper will be characterized as a felted sheet of natural or synthetic fibers, usually but not necessarily manufactured by laying fibers on a screen from a water suspension. The sheet may be reinforced with resins and subjected to any of the conventional types of treatments applied to papers, such as bleaching, callendering, etc.

The paper may be sub-coated as shown in FIG. 4 with a material which forms a stronger bond with the pressure sensitive adhesive than the release coating, the release coating being applied over the subcoating. Alternatively, the paper may be omitted entirely and the substrate can be made entirely of a material of the type referred to for the subcoating. Useful materials include polyethylene and saran, for example up to about 15 mils thick.

The release coating covers a portion only of the area of the substrate, and the covered portions are interspersed among uncovered portions. The covered portions may constitute as little as 15 percent of the area or as much as 85 percent, but preferably constitute 25 to 40 percent. The invention contemplates the possibility of a release sheet which has two adjacent areas, one of which is fully covered with the release material and therefore does not use the partial coverage concept of the present invention, the adjacent area embodying the present invention. However, in the area in which the release coating is interspersed with uncoated areas, the release coating may be present in a wide variety of patterns, some of which are shown in FIGS. 7-30. FIGS. 7-9 illustrate a solid matrix of release material with small dots uncoated, with progressively larger dots of uncoated areas. FIG. 10 is of similar type, but there is a progression from very small dots at the right to larger dots. At the left, the dots become so large that they become a matrix around dots of release coating. This system is useful if one wants a weak bond — for ease of opening — near the outside of the package and a small area of stronger bond to assure, e.g., a hermetic seal. FIG. 11 shows two more patterns of the same type as FIG. 10. FIGS. 12-24 show various line patterns, the dark areas representing areas coated with release material. Miscellaneous patterns are shown in FIGS. 26-30. The patterns in FIGS. 12-15, 26, 27, 29 and 30 would permit gases to move through the seal whereas FIGS. 16-25 and 28 show various patterns useful for hermetic seals.

It also is possible to make the release sheet of the invention from a conventional release sheet by removing portions of the release coating. One way of doing this is illustrated in FIG. 6 where release paper 19 is passed under a rotating wire brush 20 with the release coating facing the brush which scrapes off portions of the release coating to produce a sheet which under magnification would have an appearance similar to FIG. 26 or FIG. 30 depending on the amount of coating removed.

As indicated above, the practice of the invention involves having the coated areas interspersed among uncoated areas rather than providing large adjacent areas of each kind. Thus, in an area of, e.g., 1 square centimeter, at least a portion of the surface is coated and a portion is uncoated. By this means, improved adhesion is obtained.

The pressure sensitive tape described in the above embodiments can be pre-applied to the stock from which the packages are made. For example, application to a plastic film is shown in FIG. 30'. The film so made can be converted to packages by the method described in U.S. Pat. No. 3,613,874. As shown in FIG. 7, the tape 21 can be applied to the center portion of the film 22 by a Beck Tear Stripper, and a tear strip can be applied by the same machine. Marks 23 have previously been applied to the film 22 to act as a guide for the tear stripper to accurately position the tape and tear strip.

FIGS. 31 and 32 illustrate the use of the invention with the package described in U.S. Pat. No. 3,272,422. Said package comprises a cup 23 adapted to hold, for example, sliced luncheon meat. The cup has a bottom 24, sidewalls 25 and a lateral flange 26 extending outwardly from the sides. A lid 27 is shown above the cup of the same size and shape as the flange 26 which will be adhered to the flange when the package is closed. The lid comprises a board 28 coated pressure sensitive adhesive layer 29, and sheet member 30 partly coated on its upper surface with a release coating according to the present invention and on its lower surface with a heat seal adhesive 32 for bonding to the flange 26.

It will be appreciated that while the invention has been described in connection with preferred embodiments, no limitation thereto is intended. Changes may be made in details of construction and mode of operation without departing from the scope of the invention hereinafter defined.

What is claimed is:

1. In a reclosable package comprising a receptacle containing a commodity and a closure having first and second facing members, a coating of pressure sensitive adhesive on said first facing member and an exposed release surface on said other facing member from which said pressure sensitive adhesive coating can be removed substantially without delamination;

the improvement wherein the release surface comprises areas of a first kind of material and areas of a second kind of material, the areas of said first kind of material forming a stronger bond with said pressure sensitive adhesive than the areas of said second kind of material.

2. A reclosable package as set forth in claim 1 in which the areas of said second kind of material are a coating over a continuous layer of said first kind of material so that said second kind of material is elevated by the thickness of said coating and the areas of said first kind of material are recessed.

3. A reclosable package as set forth in claim 2 in which said first kind of material is a fibrous material.

4. A reclosable package as set forth in claim 3 in which said fibrous material is paper.

5. A reclosable package as set forth in claim 1 in which said areas of said second kind of material comprise 15 to 85 percent of the total area of said release surface.

6. A reclosable package as set forth in claim 1 in

which said areas of said second kind of material comprise 25 to 40 percent of the total area of said release surface.

7. In a reclosable package comprising a receptacle containing a commodity and a closure having first and second facing members, and a tape between said facing members, the tape comprising first and second sheet members, said first sheet member being sealed to one of said facing members on one side of the first sheet member, said second sheet member being sealed to the other of said facing members on one side of the second sheet member, a pressure sensitive adhesive coated on the other surface of one of said sheet members and a release coating on the other surface of the other of said sheet members, the pressure sensitive adhesive being adhered to the release coating by a bond weaker than the bond between said sheet members and the respective facing members;

the improvement wherein the release coating covers only portion of the area of said sheet member leaving exposed another portion of said sheet member, the exposed portion forming a stronger bond with said pressure sensitive adhesive than said release coating.

8. A reclosable package as set forth in claim 7 in which the release coating covers 15 to 85 percent of the area of said sheet material.

9. A reclosable package as set forth in claim 8 in which the release coating covers 25 to 40 percent of the total area of said sheet material.

10. In a package comprising a receptacle having an opening for receiving and removing a product and a closure member adapted to at least partially close said opening, said closure member having a coating of pressure sensitive adhesive mass on at least a portion of the area thereof which is adjacent another portion of said receptacle, and a sheet member overlying said pressure sensitive adhesive, the outer surface of which is permanently sealable to said receptacle, with a bond strength greater than between the closure member and the sheet member, the inner surface of said sheet member having a release coating from which said closure member can be removed without substantial transfer of pressure sensitive adhesive mass to said film, whereby upon permanently sealing said film to said receptacle said closure member may be removed and then resealed to the receptacle;

the improvement wherein the release coating covers only a portion of the area of said sheet member leaving exposed another portion of said sheet member, the exposed portion forming a stronger bond with said pressure sensitive adhesive than said release coating.

11. A package as set forth in claim 10 wherein the release coating covers 15 to 85 percent of the total area of said sheet member.

12. A package as set forth in claim 11 in which the release coating covers 25 to 40 percent of the total area of said sheet member.

* * * * *