



US00D892002S

(12) **United States Design Patent**
Gander

(10) **Patent No.:** **US D892,002 S**
(45) **Date of Patent:** **** Aug. 4, 2020**

- (54) **GRILLE ELEMENT**
- (71) Applicant: **Oshkosh Corporation**, Oshkosh, WI (US)
- (72) Inventor: **Jesse Gander**, Larsen, WI (US)
- (73) Assignee: **Oshkosh Corporation**, Oshkosh, WI (US)
- (**) Term: **15 Years**
- (21) Appl. No.: **29/706,526**
- (22) Filed: **Sep. 20, 2019**

1,835,132 A	12/1931	Anania
1,941,582 A	1/1934	Schroeder
2,628,127 A	2/1953	Palsgrove
2,632,577 A	3/1953	Sacco
2,907,575 A	10/1959	Locker
2,915,334 A	12/1959	Barenyl
2,916,997 A	12/1959	Terrie
2,997,242 A	8/1961	Grosholz
3,010,533 A	11/1961	Ross
3,021,166 A	2/1962	Kempel et al.
3,039,788 A	6/1962	Farago
3,046,045 A	7/1962	Campbell
3,083,790 A	4/1963	McAfee et al.
3,131,963 A	5/1964	Schilberg
3,146,839 A	9/1964	Carlson
3,188,966 A	6/1965	Tetlow
3,306,390 A	2/1967	Jamme
3,395,672 A	8/1968	Ruf
3,500,961 A	3/1970	Eberhardt et al.
3,590,948 A	7/1971	Milner, Jr.
3,726,308 A	4/1973	Eberhardt
3,881,767 A	5/1975	Klees
4,037,664 A	7/1977	Gibson
4,059,170 A	11/1977	Young
4,084,522 A	4/1978	Younger
4,103,757 A	8/1978	McVaugh
4,153,262 A	5/1979	Diamond et al.
4,157,733 A	6/1979	Ewers et al.
4,160,492 A	7/1979	Johnston
4,185,924 A	1/1980	Graham
4,241,803 A	12/1980	Lauber
4,270,771 A	6/1981	Fujii
4,326,445 A	4/1982	Bemiss
4,329,109 A	5/1982	Den Bleyker
4,337,830 A	7/1982	Eberhardt
4,369,010 A	1/1983	Ichinose et al.
4,373,600 A	2/1983	Buschbom et al.
4,395,191 A	7/1983	Kaiser
4,456,093 A	6/1984	Finley et al.
4,492,282 A	1/1985	Appelblatt et al.
4,558,758 A	12/1985	Littman et al.
4,563,124 A	1/1986	Eskew
4,586,743 A	5/1986	Edwards et al.
4,587,862 A	5/1986	Hoffman
4,655,307 A	4/1987	Lamoureux
4,659,104 A	4/1987	Tanaka et al.
4,669,744 A	6/1987	Sano et al.
4,696,489 A	9/1987	Fujishiro et al.
4,709,358 A	11/1987	Appling et al.
4,733,876 A	3/1988	Heider et al.
4,811,804 A	3/1989	Ewers et al.
4,826,141 A	5/1989	Buma et al.
4,834,418 A	5/1989	Buma et al.

Related U.S. Application Data

- (63) Continuation of application No. 29/691,172, filed on May 14, 2019, now Pat. No. Des. 863,144, which is a continuation of application No. 29/621,906, filed on Oct. 12, 2017, now Pat. No. Des. 856,860, which is a continuation of application No. 15/599,174, filed on May 18, 2017, now Pat. No. 10,434,995, which is a continuation of application No. 14/724,279, filed on May 28, 2015, now Pat. No. 9,656,640, and a continuation of application No. 14/612,100, filed on Feb. 2, 2015, now Pat. No. 9,829,282, and a continuation of application No. 13/841,686, filed on Mar. 15, 2013, now Pat. No. 9,045,014, and a continuation of application No. 13/629,009, filed on Sep. 27, 2012, now Pat. No. 8,943,946.
- (51) **LOC (12) Cl.** **12-16**
- (52) **U.S. Cl.**
USPC **D12/163**
- (58) **Field of Classification Search**
USPC D12/163, 164, 190, 195, 196, 414
CPC B60R 9/06; B62D 35/02; B62D 39/00;
B62D 65/16; B62D 21/12; B29C 45/16
See application file for complete search history.

References Cited

U.S. PATENT DOCUMENTS

1,001,863 A	8/1911	Kirkwood
1,278,460 A	9/1918	Hanger
1,376,467 A	5/1921	Simmon
1,463,569 A	7/1923	Bathrick

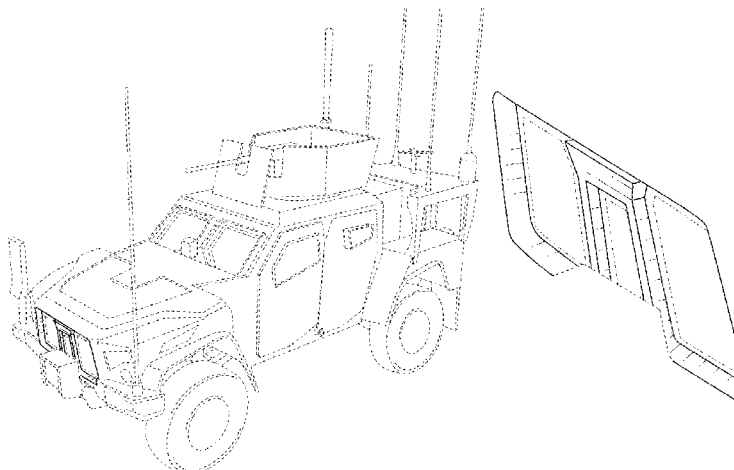

US D892,002 S

Page 2

4,926,954 A	5/1990	Ataka et al.	6,398,236 B1	6/2002	Richardson
4,945,780 A	8/1990	Bosma	6,398,478 B2	6/2002	Smith et al.
5,004,156 A	4/1991	Montanier	6,421,593 B1	7/2002	Kempen et al.
5,010,971 A	4/1991	Hamada et al.	6,435,071 B1	8/2002	Campbell
5,021,917 A	6/1991	Pike et al.	6,435,298 B1	8/2002	Mizuno et al.
5,028,088 A	7/1991	Del Monico et al.	6,443,687 B1	9/2002	Kaiser
5,040,823 A	8/1991	Lund	6,460,907 B2	10/2002	Usui
5,054,806 A	10/1991	Chester	6,503,035 B1	1/2003	Perrott
5,076,597 A	12/1991	Korekane et al.	6,516,914 B1	2/2003	Andersen et al.
5,080,392 A	1/1992	Bazergui	6,520,494 B1	2/2003	Andersen et al.
5,111,901 A	5/1992	Bachhuber et al.	6,527,494 B2	3/2003	Hurlburt
5,113,946 A	5/1992	Cooper	D473,829 S	4/2003	Hoyle, Jr.
5,137,101 A	8/1992	Schaeff	6,553,290 B1	4/2003	Pillar
5,137,292 A	8/1992	Eisen	6,561,718 B1	5/2003	Archer et al.
5,139,104 A	8/1992	Moscicki	6,619,673 B2	9/2003	Eckelberry et al.
5,143,326 A	9/1992	Parks	6,623,020 B1	9/2003	Satou
5,156,614 A	10/1992	Takeuchi	6,658,984 B2	12/2003	Zonak
5,169,197 A	12/1992	Underbakke et al.	6,692,366 B1	2/2004	Savant
5,209,003 A	5/1993	Maxfield et al.	6,695,328 B2	2/2004	Cope
5,211,245 A	5/1993	Relyea et al.	6,702,058 B2	3/2004	Ishii et al.
5,217,083 A	6/1993	Bachhuber et al.	6,736,232 B1	5/2004	Bergstrom et al.
5,301,756 A	4/1994	Relyea et al.	6,757,597 B2	6/2004	Yakes et al.
5,322,321 A	6/1994	Yopp	6,764,085 B1	7/2004	Anderson
5,327,989 A	7/1994	Furuhashi et al.	6,769,733 B2	8/2004	Seksaria et al.
5,346,334 A	9/1994	Einaru et al.	6,779,806 B1	8/2004	Breitbach et al.
5,368,317 A	11/1994	McCombs et al.	6,820,908 B1	11/2004	Tousi et al.
5,390,945 A	2/1995	Orr	6,848,693 B2	2/2005	Schneider
5,438,908 A	8/1995	Madden, Jr.	6,860,332 B1	3/2005	Archer et al.
5,467,827 A	11/1995	McLoughlin	6,882,917 B2	4/2005	Pillar et al.
5,487,323 A	1/1996	Madden, Jr.	6,883,815 B2	4/2005	Archer
5,501,288 A	3/1996	Ducote	6,885,920 B2	4/2005	Yakes et al.
5,533,781 A	7/1996	Williams	6,899,191 B1	5/2005	Lykken
5,538,185 A	7/1996	Rabitsch et al.	6,909,944 B2	6/2005	Pillar et al.
5,538,274 A	7/1996	Schmitz et al.	6,922,615 B2	7/2005	Pillar et al.
5,553,673 A	9/1996	Hackman	6,923,453 B2	8/2005	Pivac
5,617,696 A	4/1997	Young	6,925,735 B2	8/2005	Hamm et al.
5,663,520 A	9/1997	Ladika et al.	6,959,466 B2	11/2005	Alowonle et al.
5,670,734 A	9/1997	Middione et al.	6,976,688 B2	12/2005	Archer et al.
5,679,918 A	10/1997	Korpi et al.	6,993,421 B2	1/2006	Pillar et al.
5,637,669 A	11/1997	Engler	7,006,902 B2	2/2006	Archer et al.
5,716,066 A	2/1998	Chou et al.	7,024,296 B2	4/2006	Squires et al.
5,746,396 A	5/1998	Thorton-Trump	7,072,745 B2	7/2006	Pillar et al.
5,752,862 A	5/1998	Mohler et al.	7,073,620 B2	7/2006	Braun et al.
5,785,372 A	7/1998	Glatzmeier et al.	D528,482 S	9/2006	Hamburger
5,738,158 A	8/1998	Relyea	7,107,129 B2	9/2006	Rowe et al.
5,794,966 A	8/1998	MacLeod	7,114,764 B1	10/2006	Barsoum et al.
5,807,056 A	9/1998	Osborn et al.	7,127,331 B2	10/2006	Pillar et al.
5,820,150 A	10/1998	Archer et al.	D533,485 S	12/2006	Schiavone et al.
D400,835 S	11/1998	Le Quemant et al.	7,144,039 B2	12/2006	Kawasaki et al.
5,836,657 A	11/1998	Tilley et al.	D535,589 S	1/2007	Lau et al.
5,839,664 A	11/1998	Relyea	7,162,332 B2	1/2007	Pillar et al.
RE36,196 E	4/1999	Eberhardt	7,164,977 B2	1/2007	Yakes et al.
5,897,123 A	4/1999	Cherney et al.	7,184,662 B2	2/2007	Arbel et al.
5,899,276 A	5/1999	Relyea et al.	7,184,862 B2	2/2007	Pillar et al.
5,900,199 A	5/1999	Dickson et al.	7,184,866 B2	2/2007	Squires et al.
5,905,225 A	5/1999	Joynt	7,188,893 B2	3/2007	Akasaka
5,909,780 A	6/1999	De Andrade	7,198,130 B2	4/2007	Schimke
5,915,728 A	6/1999	Blackburn	7,198,278 B2	4/2007	Donaldson
5,915,775 A	6/1999	Martin et al.	7,207,582 B2	4/2007	Siebers et al.
5,919,240 A	7/1999	Ney et al.	7,213,872 B2	5/2007	Ronacher et al.
5,954,364 A	9/1999	Nechushtan	7,234,534 B2	6/2007	Froland et al.
6,009,953 A	1/2000	Laskaris et al.	7,240,906 B2	7/2007	Klees
6,015,155 A	1/2000	Brookes et al.	7,246,835 B1	7/2007	Colburn et al.
6,036,201 A	3/2000	Pond et al.	7,254,468 B2	8/2007	Pillar et al.
6,105,984 A	8/2000	Schmitz et al.	7,258,194 B2	8/2007	Braun et al.
6,109,684 A	8/2000	Reitnouer	7,267,394 B1	9/2007	Mouch et al.
6,131,685 A	10/2000	Sakamoto et al.	7,270,346 B2	9/2007	Rowe et al.
6,155,351 A	12/2000	Breedlove et al.	7,274,976 B2	9/2007	Rowe et al.
6,178,746 B1	1/2001	Thoma et al.	7,277,782 B2	10/2007	Yakes et al.
6,220,532 B1	4/2001	Manon et al.	7,281,600 B2	10/2007	Chernoff et al.
6,231,466 B1	5/2001	Thoma et al.	7,302,320 B2	11/2007	Nasr et al.
6,270,098 B1	8/2001	Heyring et al.	7,306,069 B2	12/2007	Takeshima et al.
6,270,153 B1	8/2001	Toyao et al.	D561,665 S	2/2008	Thomas et al.
6,289,995 B1	9/2001	Fuller	7,329,161 B2	2/2008	Roering
6,311,795 B1	11/2001	Skotnikov et al.	7,357,203 B2	4/2008	Morrow et al.
6,318,742 B2	11/2001	Franzini	7,377,549 B2	5/2008	Hasegawa et al.
6,357,769 B1	3/2002	Omundson et al.	7,379,797 B2	5/2008	Nasr et al.
6,394,007 B2	5/2002	Lewis et al.	7,380,800 B2	6/2008	Klees
6,394,534 B1	5/2002	Dean	7,392,122 B2	6/2008	Pillar et al.

US D892,002 S

7,393,016 B2	7/2008	Mitsui et al.	D686,121 S	7/2013	McCabe et al.	
7,406,909 B2	8/2008	Shah et al.	8,561,735 B2	10/2013	Morrow et al.	
7,412,307 B2	8/2008	Pillar et al.	8,578,834 B2	11/2013	Tunis et al.	
7,419,021 B2	9/2008	Morrow et al.	8,596,183 B2	12/2013	Coltrane	
7,425,891 B2	9/2008	Colburn et al.	8,596,648 B2	12/2013	Venton-Walters et al.	
7,439,711 B2	10/2008	Bolton	8,601,931 B2	12/2013	Naroditsky et al.	
7,441,615 B2	10/2008	Borroni-Bird et al.	8,616,617 B2	12/2013	Sherbeck et al.	
7,441,809 B1	10/2008	Coombs et al.	D698,281 S	1/2014	Badstuebner et al.	
7,448,460 B2	11/2008	Morrow et al.	D702,615 S	4/2014	Conway et al.	
7,451,028 B2	11/2008	Pillar et al.	D703,119 S	4/2014	Platto et al.	
7,472,914 B2	1/2009	Anderson et al.	8,746,741 B2	6/2014	Gonzalez	
7,472,919 B2	1/2009	Pratt et al.	8,764,029 B2	7/2014	Venton-Walters et al.	
7,510,235 B2	3/2009	Kobayashi et al.	8,801,017 B2	8/2014	Ellifson et al.	
7,520,354 B2	4/2009	Morrow et al.	8,863,884 B2	10/2014	Jacob-Lloyd	
7,522,979 B2	4/2009	Pillar	D718,683 S	12/2014	Thole et al.	
7,555,369 B2	6/2009	Pillar et al.	8,905,164 B1	12/2014	Capouellez et al.	
D597,002 S	7/2009	Jamieson et al.	8,921,130 B2	12/2014	Kundaliya et al.	
7,594,561 B2	9/2009	Hass et al.	8,943,946 B1	2/2015	Richmond et al.	
7,611,153 B2	11/2009	Kim et al.	8,947,531 B2	2/2015	Fischer et al.	
7,611,154 B2	11/2009	Delaney	8,955,859 B1	2/2015	Richmond et al.	
7,618,063 B2	11/2009	Takeshima et al.	8,967,699 B1	3/2015	Richmond et al.	
7,624,835 B2	12/2009	Bowers	8,991,834 B2	3/2015	Venton-Walters et al.	
7,624,995 B2	12/2009	Barbison	8,991,840 B2	3/2015	Zuleger et al.	
7,681,892 B1	3/2010	Crews et al.	9,016,703 B2	4/2015	Rowe et al.	
7,689,332 B2	3/2010	Yakes et al.	9,045,014 B1	6/2015	Verhoff et al.	
7,695,053 B1	4/2010	Boczek et al.	D735,625 S	8/2015	Mays et al.	
7,699,385 B2	4/2010	Kurata	D739,317 S	9/2015	McMahan et al.	
7,711,460 B2	5/2010	Yakes et al.	D740,187 S	10/2015	Jamieson	
7,715,962 B2	5/2010	Rowe et al.	D743,308 S	11/2015	Hanson et al.	
7,725,225 B2	5/2010	Pillar et al.	D743,856 S	11/2015	Ma	
7,726,429 B2	6/2010	Suzuki	9,174,686 B1	11/2015	Messina et al.	
7,729,831 B2	6/2010	Pillar et al.	9,221,496 B2	12/2015	Barr et al.	
D619,062 S	7/2010	Improta	D749,464 S	2/2016	Giolito	
7,756,621 B2	7/2010	Pillar et al.	9,328,986 B1	5/2016	Pennau et al.	
7,757,805 B2	7/2010	Wakuta et al.	D762,148 S	7/2016	Platto et al.	
7,770,506 B2	8/2010	Johnson et al.	9,409,471 B2	8/2016	Hoppe et al.	
D623,100 S	9/2010	Bimbi	D765,566 S	9/2016	Vena et al.	
7,789,010 B2	9/2010	Allor et al.	D769,160 S	* 10/2016	Platto	D12/163
7,792,618 B2	9/2010	Quigley et al.	D772,768 S	11/2016	Chiang	
7,802,816 B2	9/2010	McGuire	D774,994 S	* 12/2016	Alemanly	D12/163
D627,686 S	11/2010	Thompson et al.	D775,021 S	12/2016	Harriton et al.	
7,835,838 B2	11/2010	Pillar et al.	D777,220 S	1/2017	Powell	
7,848,857 B2	12/2010	Nasr et al.	D777,615 S	1/2017	Hanson et al.	
7,905,534 B2	3/2011	Boczek et al.	D778,217 S	2/2017	Ito et al.	
7,905,540 B2	3/2011	Kiley et al.	D784,219 S	4/2017	Jung	
7,908,959 B2	3/2011	Pavon	D787,993 S	5/2017	McCabe et al.	
D636,305 S	4/2011	Alvarez et al.	9,650,005 B2	5/2017	Patelczyk et al.	
7,931,103 B2	4/2011	Morrow et al.	9,656,640 B1	5/2017	Verhoff et al.	
7,934,766 B2	5/2011	Boczek et al.	D790,409 S	* 6/2017	Baste	D12/163
7,938,478 B2	5/2011	Kamimae	D797,603 S	9/2017	Noone et al.	
D642,099 S	7/2011	Nagao et al.	D802,491 S	* 11/2017	Mainville	D12/163
7,997,182 B1	8/2011	Cox	D804,372 S	12/2017	Kozub	
8,000,850 B2	8/2011	Nasr et al.	D805,965 S	* 12/2017	Davis	D12/163
D646,203 S	10/2011	Thompson et al.	D813,757 S	3/2018	Kozub	
D646,607 S	10/2011	Verhee et al.	D813,758 S	3/2018	Gonzales	
8,029,021 B2	10/2011	Leonard et al.	D815,574 S	4/2018	Manville	
8,033,208 B2	10/2011	Joynt et al.	D824,294 S	* 7/2018	Ge	D12/163
D649,908 S	12/2011	Mullen	D824,811 S	* 8/2018	Mainville	D12/163
D649,909 S	12/2011	Mullen	D824,814 S	* 8/2018	Heyde	D12/163
8,095,247 B2	1/2012	Pillar et al.	D830,242 S	* 10/2018	Zipfel	D12/163
8,096,225 B1	1/2012	Johnson et al.	D837,106 S	* 1/2019	Yang	D12/163
D655,226 S	3/2012	Hanson et al.	D837,702 S	1/2019	Gander et al.	
8,139,109 B2	3/2012	Schmiedel et al.	D843,281 S	3/2019	Gander et al.	
8,146,477 B2	4/2012	Joynt	D853,285 S	* 7/2019	Yang	D12/163
8,146,478 B2	4/2012	Joynt et al.	D856,860 S	8/2019	Gander	
D661,231 S	6/2012	Galante et al.	D859,226 S	* 9/2019	Grooms	D12/163
8,205,703 B2	6/2012	Halliday	D860,887 S	9/2019	Gander et al.	
D662,865 S	7/2012	Van Braeckel	D863,144 S	10/2019	Gander	
8,333,390 B2	12/2012	Linsmeier et al.	D864,031 S	10/2019	Gander et al.	
8,347,775 B2	1/2013	Altenhof et al.	D869,332 S	12/2019	Gander et al.	
8,376,077 B2	2/2013	Venton-Walters	2001/0015559 A1	8/2001	Storer	
8,402,878 B2	3/2013	Schreiner et al.	2002/0129696 A1	9/2002	Pek et al.	
8,413,567 B2	4/2013	Luther et al.	2002/0130771 A1	9/2002	Osborne et al.	
8,413,568 B2	4/2013	Kosheleff	2002/0153183 A1	10/2002	Puterbaugh et al.	
8,424,443 B2	4/2013	Gonzalez	2002/0190516 A1	12/2002	Henksmeier et al.	
8,430,196 B2	4/2013	Halliday	2003/0001346 A1	1/2003	Hamilton et al.	
D683,675 S	6/2013	Munson et al.	2003/0155164 A1	8/2003	Mantini et al.	
8,459,619 B2	6/2013	Trinh et al.	2004/0113377 A1	6/2004	Klees	
8,465,025 B2	6/2013	Venton-Walters et al.	2004/0130168 A1	7/2004	O'Connell	

2004/0149500 A1 8/2004 Chernoff et al.
 2004/0256024 A1 12/2004 Schlachter
 2005/0034911 A1 2/2005 Darby
 2005/0062239 A1 3/2005 Shore
 2005/0093265 A1 5/2005 Niaura et al.
 2005/0099885 A1 5/2005 Tamminga
 2005/0110229 A1 5/2005 Kimura et al.
 2005/0132873 A1 6/2005 Diaz Supisiche et al.
 2005/0161891 A1 7/2005 Trudeau et al.
 2005/0196269 A1 9/2005 Racer et al.
 2005/0284682 A1 12/2005 Hass et al.
 2006/0021764 A1 2/2006 Archer et al.
 2006/0048986 A1 3/2006 Bracciano
 2006/0082079 A1 4/2006 Eichhorn et al.
 2006/0192354 A1 8/2006 Van Cayzele
 2006/0201727 A1 9/2006 Chan
 2006/0244225 A1 11/2006 Power et al.
 2006/0273566 A1 12/2006 Hepner et al.
 2007/0088469 A1 4/2007 Schmiedel et al.
 2007/0102963 A1 5/2007 Frederick et al.
 2007/0120334 A1 5/2007 Holbrook
 2007/0145816 A1 6/2007 Gile
 2007/0158920 A1 7/2007 Delaney
 2007/0186762 A1 8/2007 Dehart et al.
 2007/0234896 A1 10/2007 Joynt
 2007/0246902 A1 10/2007 Trudeau et al.
 2008/0017426 A1 1/2008 Walters et al.
 2008/0017434 A1 1/2008 Harper et al.
 2008/0034953 A1 2/2008 Barbe et al.
 2008/0053739 A1 3/2008 Chernoff et al.
 2008/0066613 A1 3/2008 Mills et al.
 2008/0099213 A1 5/2008 Morrow et al.
 2008/0252025 A1 10/2008 Plath
 2008/0284118 A1 11/2008 Venton-Walters et al.
 2009/0001761 A1 1/2009 Yasuhara et al.
 2009/0061702 A1 3/2009 March
 2009/0174158 A1 7/2009 Anderson et al.
 2010/0019538 A1 1/2010 Kiley et al.
 2010/0026046 A1 2/2010 Mendoza et al.
 2010/0032932 A1 2/2010 Hastings
 2010/0123324 A1 5/2010 Shoup et al.
 2010/0163330 A1 7/2010 Halliday
 2010/0187864 A1 7/2010 Tsuchida
 2010/0218667 A1 9/2010 Naroditsky et al.
 2010/0264636 A1 10/2010 Fausch et al.
 2010/0307328 A1 12/2010 Hoadley et al.
 2010/0307329 A1 12/2010 Kaswen et al.
 2010/0319525 A1 12/2010 Pavon
 2011/0068606 A1 3/2011 Klimek et al.
 2011/0079134 A1 4/2011 Jacquemont et al.
 2011/0079978 A1 4/2011 Schreiner et al.
 2011/0114409 A1 5/2011 Venton-Walters
 2011/0120791 A1 5/2011 Greenwood et al.
 2011/0266838 A1 11/2011 Leopold
 2011/0291444 A1 12/2011 Ische
 2011/0314999 A1 12/2011 Luther et al.
 2012/0049570 A1 3/2012 Aizik
 2012/0097019 A1 4/2012 Sherbeck et al.
 2012/0111180 A1 5/2012 Johnson et al.
 2012/0174767 A1 7/2012 Naroditsky et al.
 2012/0181100 A1 7/2012 Halliday
 2012/0193940 A1 8/2012 Tunis et al.
 2013/0009423 A1 1/2013 Yamamoto et al.
 2013/0093154 A1 4/2013 Cordier et al.
 2013/0153314 A1 6/2013 Niedzwiecki
 2013/0205984 A1 8/2013 Henker et al.
 2013/0241237 A1 9/2013 Dziuba et al.
 2013/0263729 A1 10/2013 Johnson et al.
 2013/0312595 A1 11/2013 Lee
 2014/0035325 A1 2/2014 Naito et al.
 2014/0060304 A1 3/2014 Harmon et al.
 2014/0151142 A1 6/2014 Hoppe et al.
 2014/0262591 A1 9/2014 Turner et al.
 2015/0224847 A1 8/2015 Rowe et al.
 2015/0283889 A1 10/2015 Agnew
 2016/0047631 A1 2/2016 Berman
 2016/0257360 A1 9/2016 Mackenzie et al.
 2017/0328054 A1 11/2017 Bakken
 2017/0355400 A1 12/2017 Weston

2018/0326843 A1 11/2018 Danielson et al.
 2019/0185077 A1 6/2019 Smith et al.
 2019/0351883 A1 11/2019 Verhoff et al.

FOREIGN PATENT DOCUMENTS

CA	2478228	A1	2/2006
DE	11 86 334		1/1965
DE	36 20 603	A1	1/1987
EP	0 685 382	A1	12/1995
EP	1 633 619	B1	6/2004
EP	1 371 391	B1	12/2009
FR	1471914	A	3/1967
FR	2380176	A1	9/1978
GB	2 168 015	A0	6/1986
GB	2 400 588	A	1/2005
GB	2 400 589	A	2/2005
GB	2 400 590	A	3/2005
HK	1088583		10/2007
JP	4230421	B2	8/1992
JP	06-037090		5/1994
JP	2005-007995	A	1/2005
JP	2005-212698	A	8/2005
JP	2006-056463	A	3/2006
WO	WO-01/76912	A1	10/2001
WO	WO-03/049987	A2	6/2003
WO	WO-2007/140179	A2	12/2007

OTHER PUBLICATIONS

U.S. Appl. No. 10/171,075, filed Jun. 13, 2002, Archer et al.
 U.S. Appl. No. 14/532,679, filed Nov. 4, 2014, Oshkosh Corporation.
 U.S. Appl. No. 29/680,745, filed Feb. 19, 2019, Oshkosh Corporation.
 U.S. Appl. No. 29/683,330, filed Mar. 12, 2019, Oshkosh Corporation.
 U.S. Appl. No. 29/683,333, filed Mar. 12, 2019, Oshkosh Corporation.
 U.S. Appl. No. 29/700,665, filed Aug. 5, 2019, Oshkosh Corporation.
 U.S. Appl. No. 29/706,533, filed Sep. 20, 2019, Oshkosh Corporation.
 U.S. Appl. No. 29/706,547, filed Sep. 20, 2019, Oshkosh Corporation.

* cited by examiner

Primary Examiner — Susan Bennett Hattan

Assistant Examiner — Suzanne E Tisdell

(74) *Attorney, Agent, or Firm* — Foley & Lardner LLP

(57) CLAIM

I claim the ornamental design for a grille element, as shown and described.

DESCRIPTION

FIG. 1 is a front perspective view of the claimed design;
 FIG. 2 is a front view thereof;
 FIG. 3 is a rear view thereof;
 FIG. 4 is a left side view thereof;
 FIG. 5 is a right side view thereof;
 FIG. 6 is a top view thereof;
 FIG. 7 is a bottom view thereof;
 FIG. 8 is a second front perspective view thereof; and,
 FIG. 9 is a detailed front perspective view thereof.

Evenly-spaced broken lines depict unclaimed environmental subject matter. Dot-dash broken lines depict unclaimed boundaries of the claimed design.

1 Claim, 9 Drawing Sheets

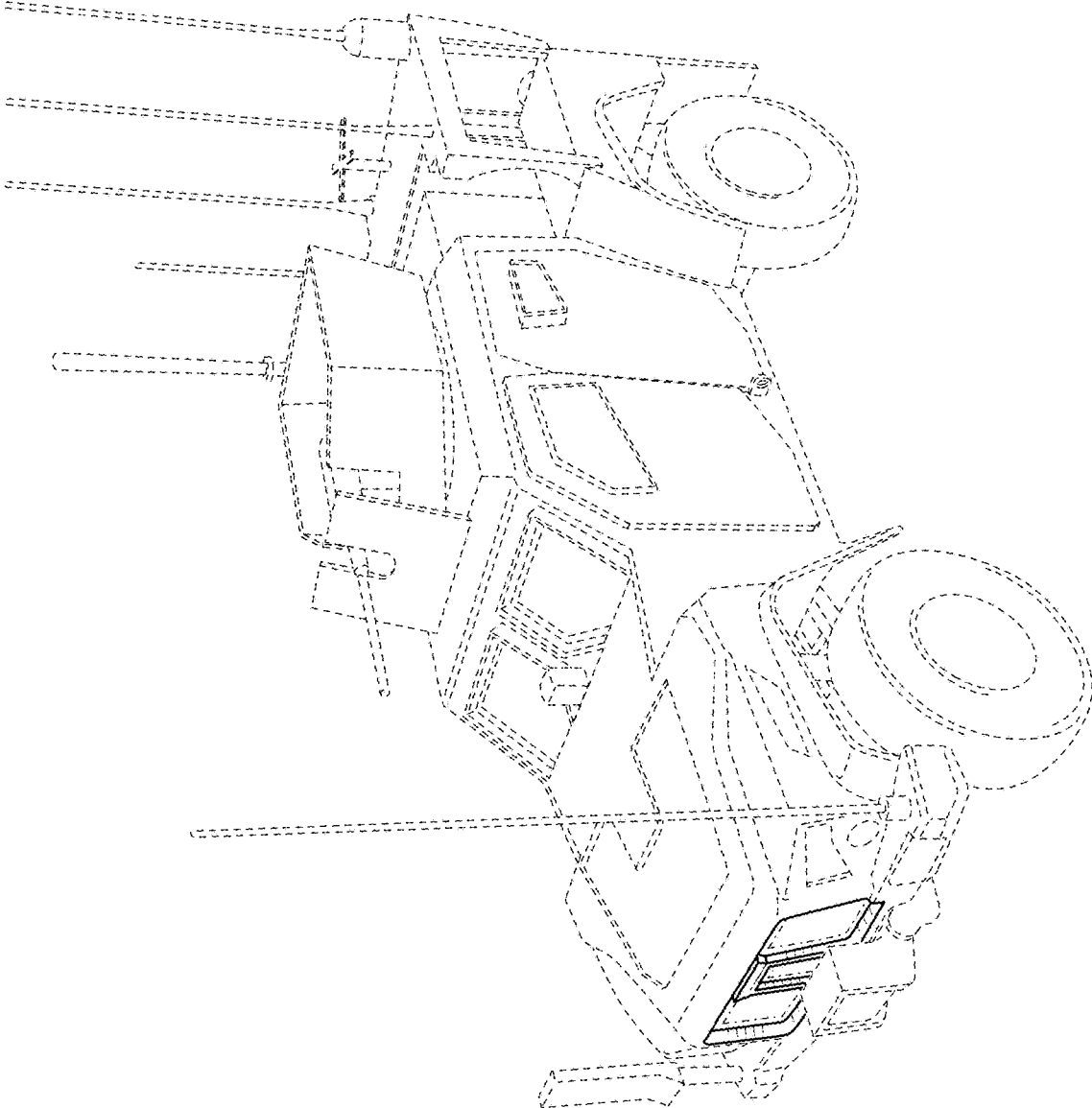

FIG. 1

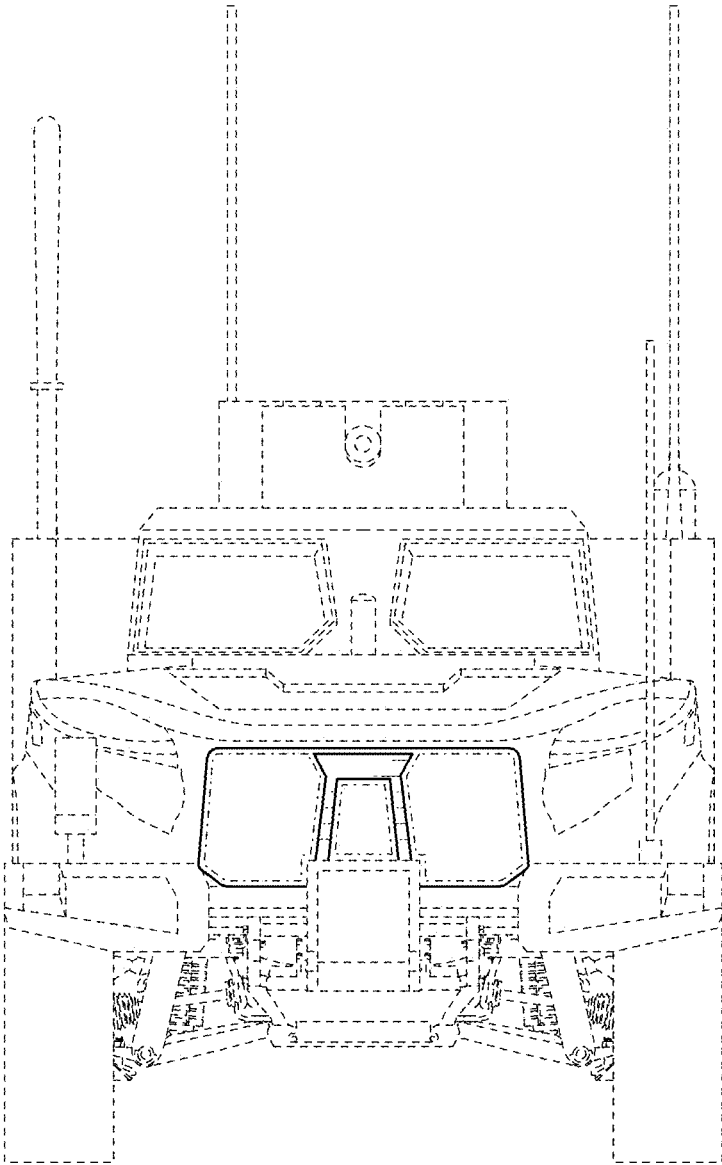

FIG. 2

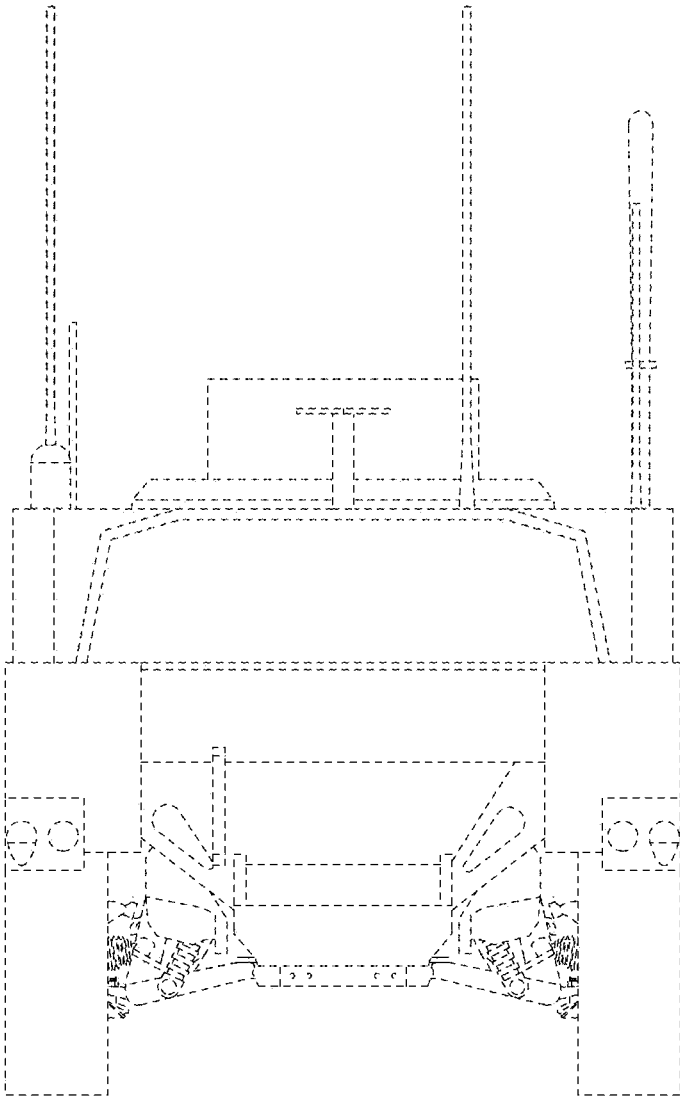

FIG. 3

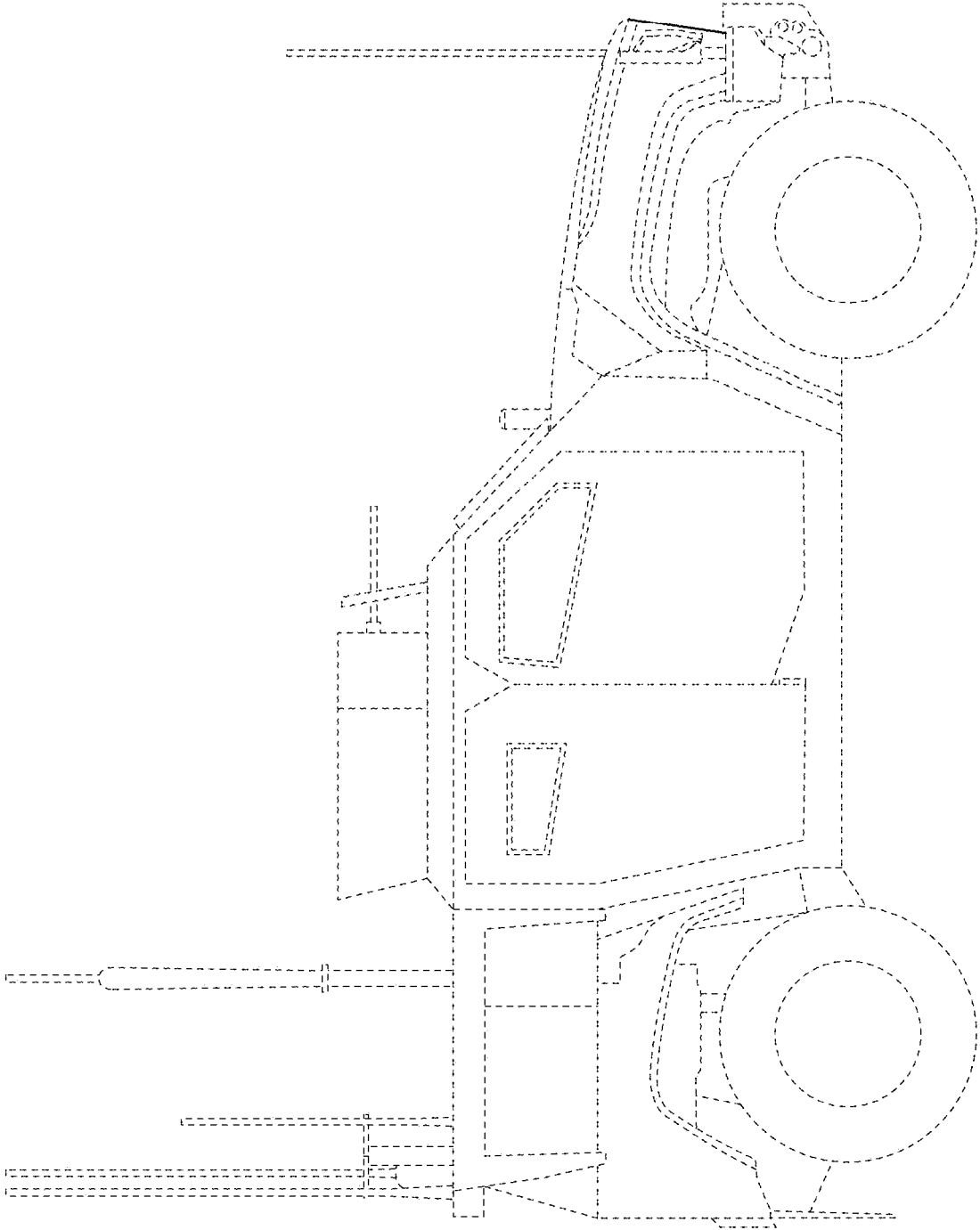

FIG. 4

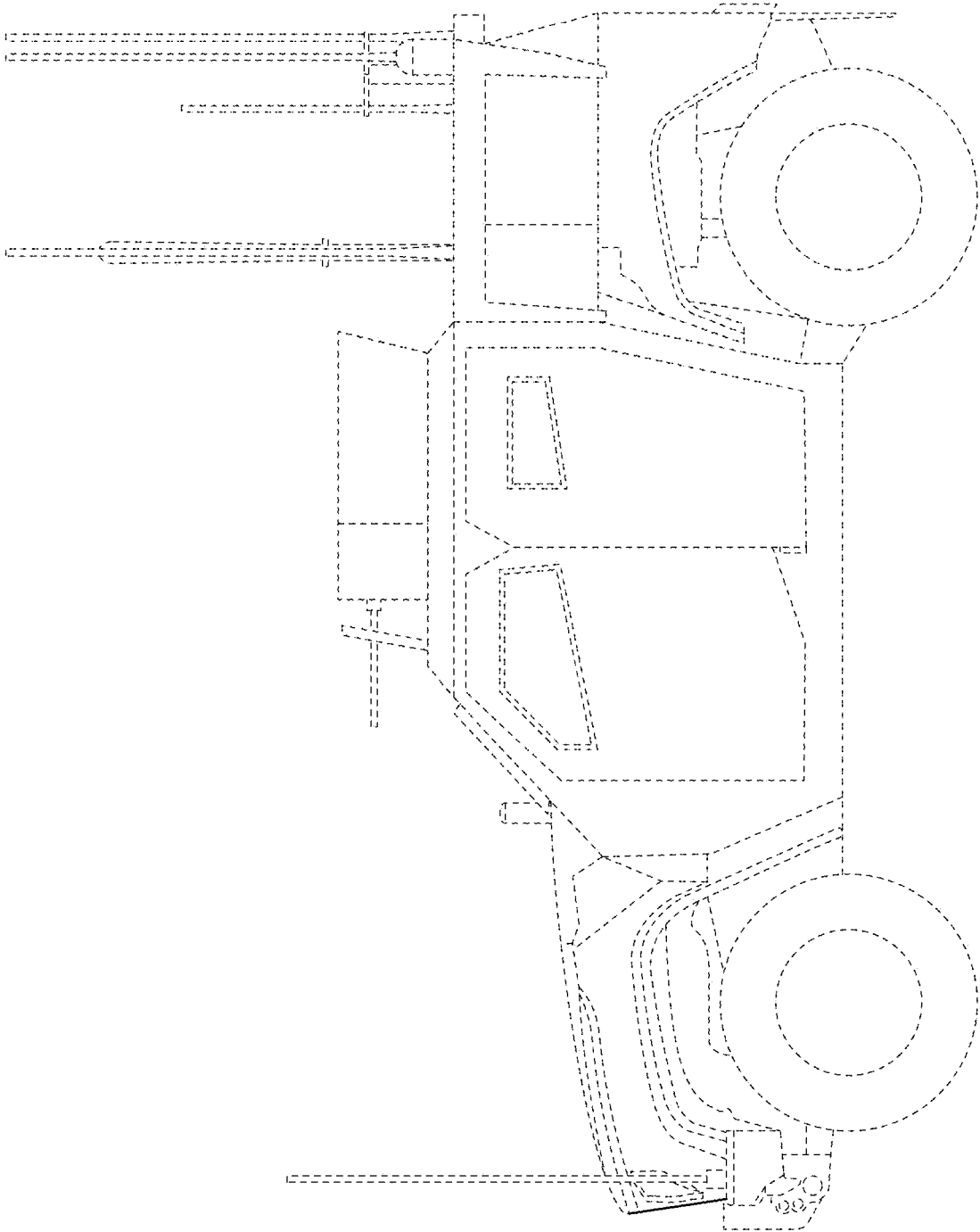

FIG. 5

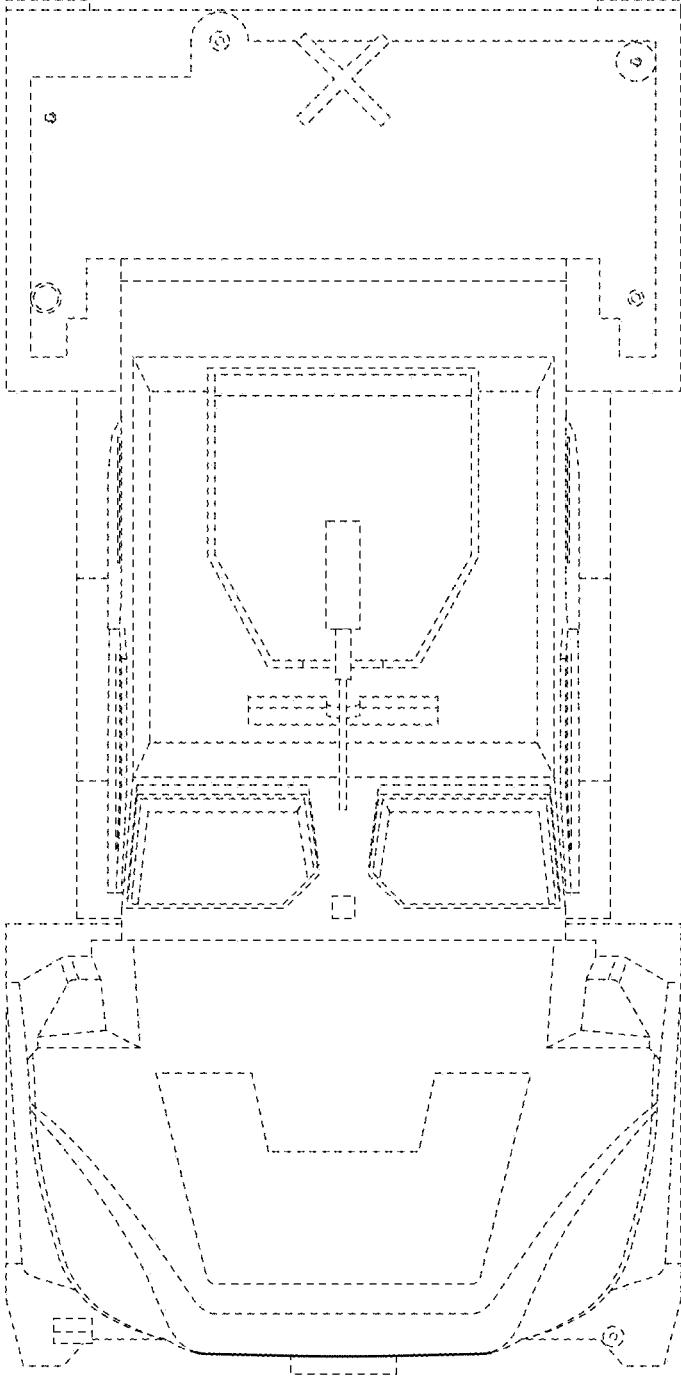

FIG. 6

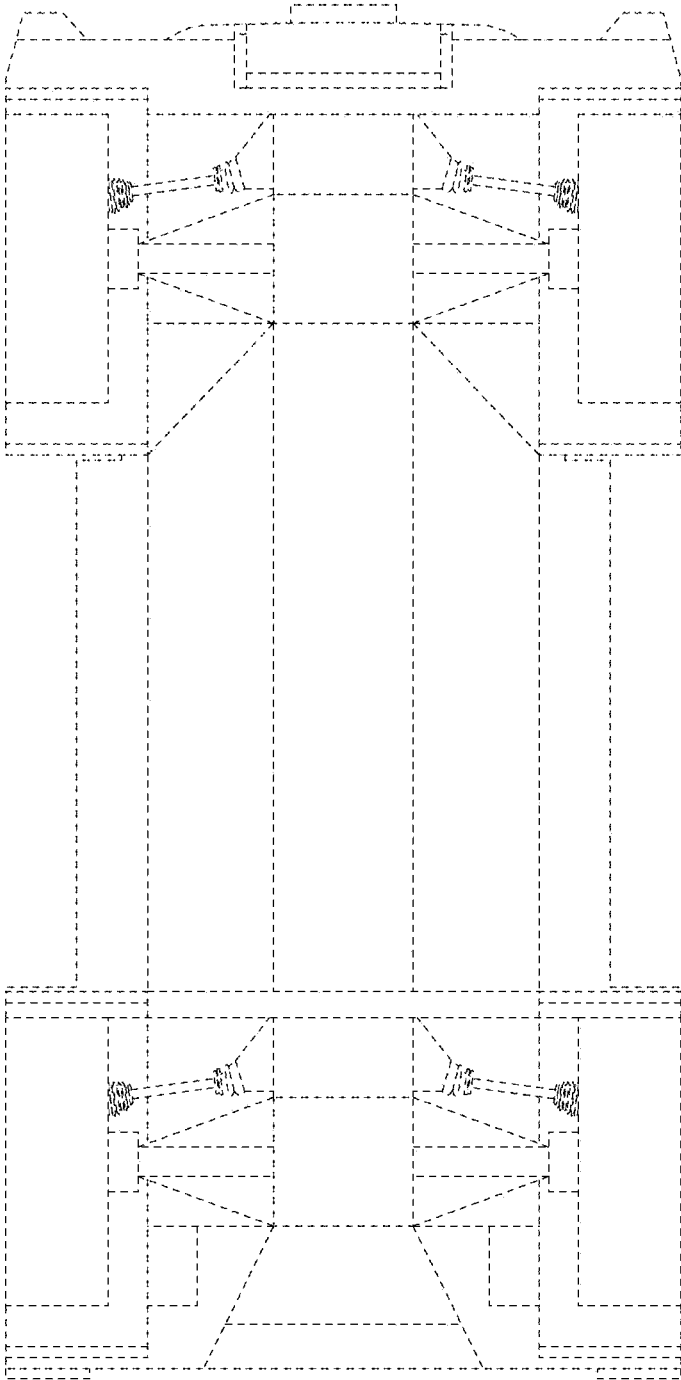

FIG. 7

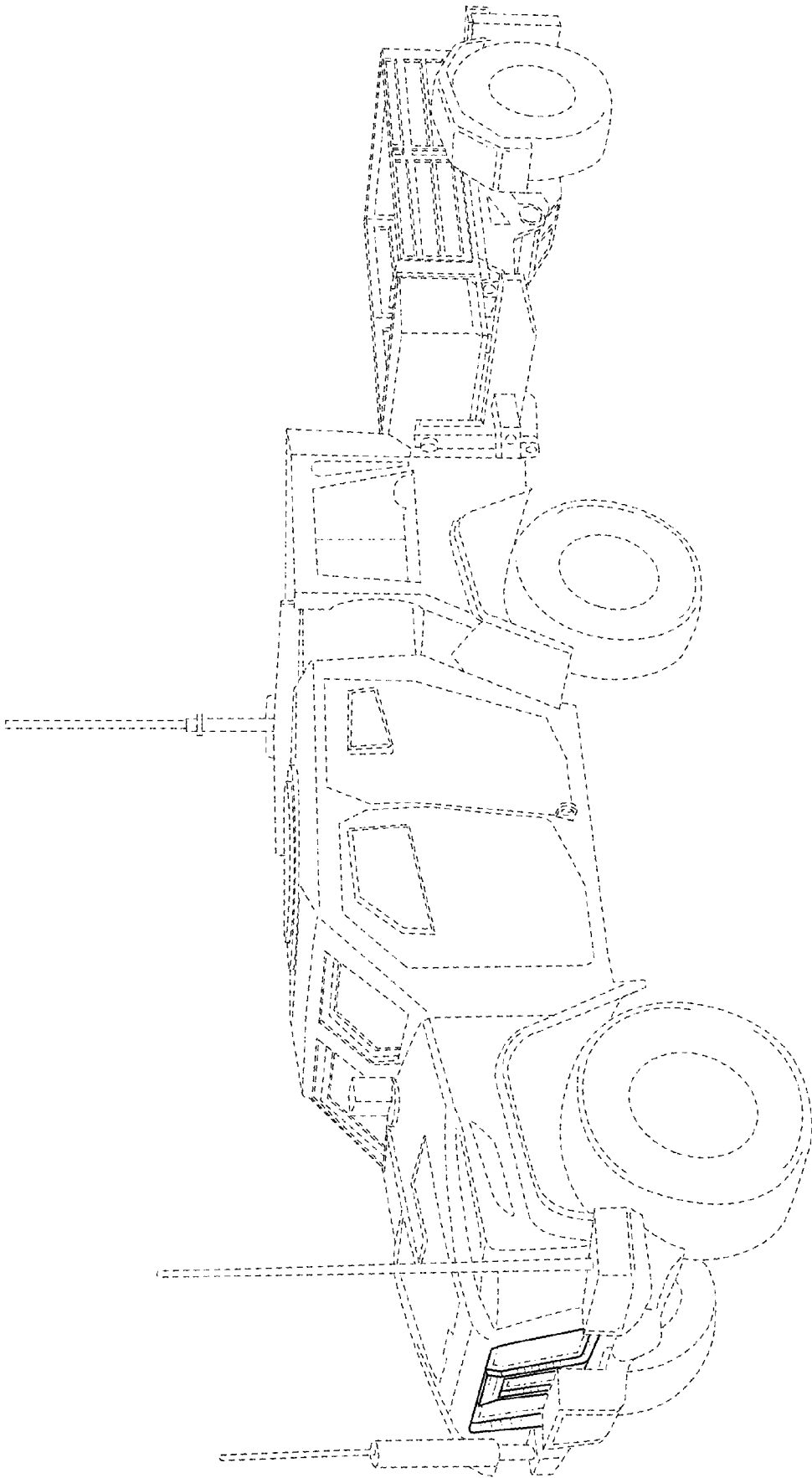

FIG. 8

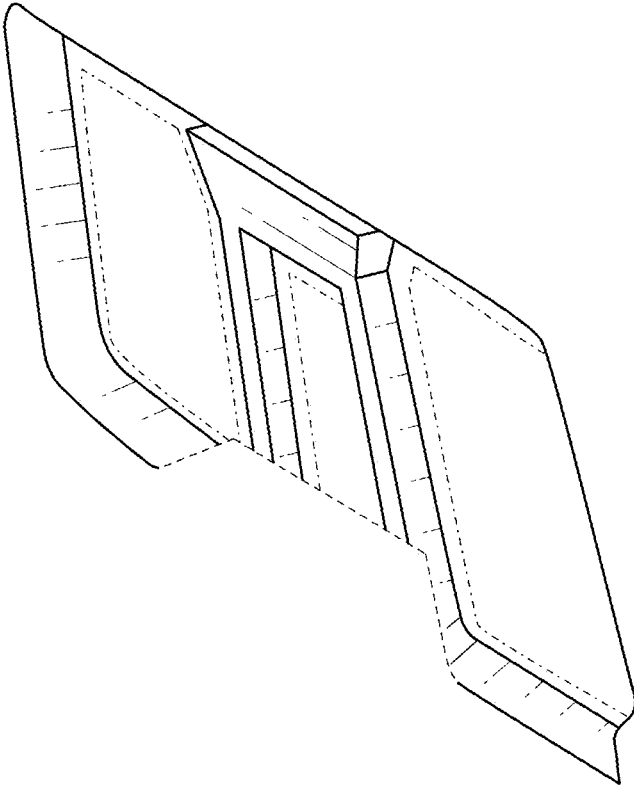

FIG. 9