

(19) World Intellectual Property Organization
International Bureau



(43) International Publication Date
23 August 2007 (23.08.2007)

PCT

(10) International Publication Number
WO 2007/094868 A2

- (51) International Patent Classification: Not classified
- (21) International Application Number: PCT/US2006/060339
- (22) International Filing Date: 27 October 2006 (27.10.2006)
- (25) Filing Language: English
- (26) Publication Language: English
- (30) Priority Data: 60/731,629 28 October 2005 (28.10.2005) US
- (71) Applicant (for all designated States except US): MOJIX, INC. [US/US]; 11075 Santa Monica Boulevard, Suite 350, Los Angeles, CA 90025 (US).
- (72) Inventor; and
- (75) Inventor/Applicant (for US only): SADR, Ramin [US/US]; 1034 Somera Road, Los Angeles, CA 90077 (US).
- (74) Agents: BRUNELL, Norman E. et al.; Irell & Manella LLP, 1800 Avenue of the Stars, Suite 900, Los Angeles, CA 90067 (US).
- (81) Designated States (unless otherwise indicated, for every kind of national protection available): AE, AG, AL, AM, AT, AU, AZ, BA, BB, BG, BR, BW, BY, BZ, CA, CH, CN, CO, CR, CU, CZ, DE, DK, DM, DZ, EC, EE, EG, ES, FI, GB, GD, GE, GH, GM, GT, HN, HR, HU, ID, IL, IN, IS, JP, KE, KG, KM, KN, KP, KR, KZ, LA, LC, LK, LR, LS, LT, LU, LV, LY, MA, MD, MG, MK, MN, MW, MX, MY, MZ, NA, NG, NI, NO, NZ, OM, PG, PH, PL, PT, RO, RS, RU, SC, SD, SE, SG, SK, SL, SM, SV, SY, TJ, TM, TN, TR, TT, TZ, UA, UG, US, UZ, VC, VN, ZA, ZM, ZW.
- (84) Designated States (unless otherwise indicated, for every kind of regional protection available): ARIPO (BW, GH, GM, KE, LS, MW, MZ, NA, SD, SL, SZ, TZ, UG, ZM, ZW), Eurasian (AM, AZ, BY, KG, KZ, MD, RU, TJ, TM), European (AT, BE, BG, CH, CY, CZ, DE, DK, EE, ES, FI, FR, GB, GR, HU, IE, IS, IT, LT, LU, LV, MC, NL, PL, PT,

[Continued on next page]

(54) Title: RFID RECEIVER

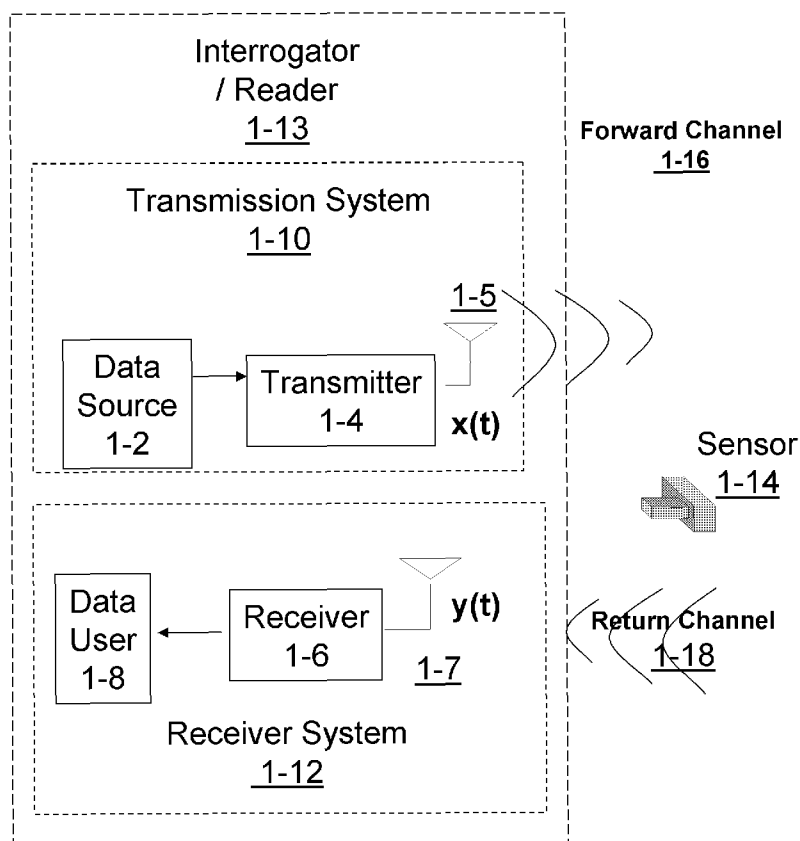

(57) Abstract: RFID data signals from RFID tags may be recovered by determining the probabilities of transitions between data states between a series of a pairs of signal samples using a set of predetermined probabilities related to data, timing, baud rate and/or phase variables affecting the received signal and processing those determined probabilities to determine the sequence of such transitions that has the highest probability of occurrence. A second set of predetermined probabilities related to transitions in the opposite direction may be used to sequence in a reverse direction. The determination of the sequence representing the RFID tag data may be iterated in both directions until further iterations don't change the determined probabilities.

WO 2007/094868 A2



RO, SE, SI, SK, TR), OAPI (BF, BJ, CF, CG, CI, CM, GA, GN, GQ, GW, ML, MR, NE, SN, TD, TG).

Published:

— *without international search report and to be republished upon receipt of that report*

Declarations under Rule 4.17:

- *as to applicant's entitlement to apply for and be granted a patent (Rule 4.17(ii))*
- *as to the applicant's entitlement to claim the priority of the earlier application (Rule 4.17(iii))*

For two-letter codes and other abbreviations, refer to the "Guidance Notes on Codes and Abbreviations" appearing at the beginning of each regular issue of the PCT Gazette.

RFID RECEIVER

CROSS REFERENCE TO RELATED APPLICATIONS

[0001] This application claims the benefit of U. S. provisional application Serial No. 60/731,629 filed October 28, 2005.

BACKGROUND OF THE INVENTION

1. Field of the Invention

[0002] This invention is related to transmitter – receiver systems and in particular is related to systems for the detection of signals in difficult environments such as for use in sensory networks and Radio Frequency Identification (RFID) systems.

2. Description of the Prior Art

[0003] The detection of signals in difficult environments, such as where the signal to noise ratio is very low and/or the interference from other signals is very high, has always been a substantial problem. In many systems today classical detection theory is used in digital transceivers. In these systems the bit stream embedded in information bearing signal is detected one-bit at a time using a "matched filter" designed to match the signal waveform at the input of the receiver.

[0004] What is needed is a robust and powerful method for the detection of extremely weak signals with severe phase and timing ambiguities due to the source characteristics and propagation environment. The proposed system has a substantial superior performance than the classical signal detector.

SUMMARY OF THE INVENTION

[0005] In a first aspect, a method for operating an RFID receiver may include sampling a received signal including RFID data signals from at least one interrogated RFID tag, providing a set of predetermined probabilities of a received signal sample making a specific transition between data states, each predetermined probability related to data, timing and baud rate variables affecting the received signal, applying the set of predetermined probabilities to each of a plurality of pairs of signal samples to determine probabilities of the received signal having made the specific transitions between each of the signal samples in that pair and processing the determined probabilities to recover RFID data signals by determining a sequence of transitions in the received signal having the highest probability of occurrence.

[0006] The predetermined probabilities may also be related to a phase variable affecting the received signal. The applying the set of predetermined probabilities, and the processing the determined probabilities, may be iterated to recover the RFID data signals. The set of predetermined probabilities may be related to transitions in a first direction. A second set of predetermined probabilities related to transitions in an opposite direction may be provided and applied to each of the plurality of pairs of signal samples to determine second probabilities of the received signal making the specific transitions between each of the signal samples in that pair in the opposite direction and the first and second determined probabilities may be processed to recover the RFID signals. Applying the first and second set of predetermined probabilities, and the processing the first and second determined probabilities, may be iterated to recover the RFID data signals. The applying and processing may be iterated until further iterations do not further change the determined probabilities.

BRIEF DESCRIPTION OF THE DRAWINGS

- [0007] Fig. 1 is a simplified block diagram of an RF transmitter-receiver system and passive sensor.
- [0008] Fig. 2a is a simplified block diagram of an end to end communication system of the type shown in Fig. 1.
- [0009] Fig. 2b is a model of a SISO implementation of the system shown in Fig. 2a.
- [0010] Fig. 3 is a diagram of a SISO decoder as a 4-Port Device.
- [0011] Fig. 4 is a block diagram of SISO processing with interleaving and de-interleaving.
- [0012] Fig. 5 is an illustration of Quantized Phase Space.
- [0013] Fig. 6 is an illustration of Quantized Time Domain.
- [0014] Fig. 7 is an illustration of Example of Trellis Diagram.
- [0015] Fig. 8a is an illustration of a Single State Trellis Transition
- [0016] Fig. 8b is an illustration of a Trellis Section.
- [0017] Fig. 9a is a block diagram of Single Parity Check Code (SPC).
- [0018] Fig. 9b is a block diagram of an RFID SISO Decoder.
- [0019] Fig. 9c represents the detailed operation of a SISO decoder for repetition code.
- [0020] Fig. 9d illustrates the operation of a SISO decoder for SPC.
- [0021] Fig. 10 is a block Coherent SISO Decoder.
- [0022] Fig. 11 is a block Non-Coherent SISO Decoder.
- [0023] Fig. 12a illustrates a block Cascaded Non-Coherent.
- [0024] Fig. 12b illustrates a Coherent SISO Decoder.
- [0025] Fig. 13a is a block diagram of an RFID System.
- [0026] Fig. 13b is a block diagram of a reader/interrogator of Fig. 13a.
- [0027] Fig. 14a is block diagram of FM0 encoder for RFID applications.
- [0028] Fig. 14b is block diagram of Miller encoder for RFID applications.
- [0029] Fig. 15a is a block diagram of classical coherent detector.
- [0030] Fig. 15b is a block diagram of classical non-coherent detector.
- [0031] Fig. 15c is a block diagram of a multiple symbol non-coherent detector.
- [0032] Fig. 15d illustrates the operation of the multiple symbol non-coherent detector of Fig. 15c.

- [0033] Fig. 16 shows a trellis diagram for FM0 and Miller code.
- [0034] Fig. 17 shows a bit error rate as function of signal-to-noise ratio.
- [0035] Fig. 18 shows a first method for a timing trellis section for pulses with time varying duration.
- [0036] Fig. 19 shows timing tick marks for the method Fig. 18.
- [0037] Fig. 20 shows a second method using a folded timing trellis for pulses with time varying duration.
- [0038] Fig. 21 shows a tree diagram with three transitions per node.
- [0039] Fig. 22 shows an example of a symbol tree structure method 3 for $N=4$, and $\Delta_{\max}=1$.
- [0040] Fig. 23 shows an example of symbol tree with windowed structure method 3 for $N=4$, and $\Delta_{\max}=1$.
- [0041] Fig. 24 shows a SISO implementation: Intermediate metric variable computation.
- [0042] Fig. 25 shows a SISO implementation: Interconnect of node processors and branch select units.
- [0043] Fig. 26 shows a SISO implementation: Extended parallel source node processing.
- [0044] Fig. 27 shows a Forward and Backward processor.

DETAILED DESCRIPTION OF A PREFERRED EMBODIMENT

[0045] Receiver subsystems may provide enhanced detection of signals where some latency may be tolerated, particularly for use in sensory networks and passive Radio Frequency Identification (RFID) based systems. Such systems may use iterative processing techniques with soft-input-soft-output (SISO) components to combine channel decoding with equalization, demodulation, phase tracking, symbol timing and synchronization and interference cancellation. This is achieved with exchange of probabilities or "soft information" or equivalently the probability of correct detection of transmitted symbols based on the observed vector, at any given state of a finite state machine (FSM) which models the observation space. The evolution of FSM in time domain results into a planar graph referred to here as the "Trellis". In the presence of additive white Gaussian noise (AWGN) with random phase and timing, the performance of the receiver using SISO approaches that of an ideal coherent receiver. In the presence of other channel anomalies such as multipath, fading and jamming, the performance gain is much greater than conventional systems. The SISO decoders described here can also be used for applications where serial or parallel concatenated channel coding methods is employed.

[0046] The system disclosed herein may use iterative algorithms that can be applied to a broad range of sensory class of signals and waveforms. Iterative processing techniques with soft-input-soft-output (SISO) components may be used to combine channel decoding with equalization, demodulation, phase tracking, symbol timing and synchronization and interference cancellation. This is achieved with exchange of probabilities or "soft information". When the transmitted sequence is produced from a binary symmetric source (BSS) and in presence of additive white Gaussian noise (AWGN), channel distortion, random phase and synchronization error, the performance of the receiver converges to the ideal coherent receiver for un-coded signal. In presence of other channel anomalies such as multipath, fading and jamming, the expected performance gain is much greater than conventional systems. The overall SISO decoders described here can also be used for applications where serial or parallel concatenated channel coding methods are employed.

[0047] Referring now to Fig. 1, transmission system 1-10 transmits a signal in forward channel 1-16, such as an RF channel, which is applied to sensor 1-14 which may be an RFID tag. The transmitted signal $x(t)$ in forward channel 1-16 may be modeled as the real part of

the complex transmitted signal, that is $x(t) = \text{Real}[a(t)e^{j(\omega_c t + \theta)}]$ for $t \in [nT_{sym}, (n+1)T_{sym})$; where T_{sym} denotes the symbol time interval, $a(t)$ may be complex or real-valued information bearing signal and θ denotes the phase of the transmitted signal during the symbol time. This phase can be time varying from symbol to symbol. In passive RFID tag applications, the transmitted and received waveforms are independent, however, the power transmitted from the tag 1-14 depends on the power of the signal from the reader and the tag efficiency to convert its received power to available transmit power back to the reader. In active sensors, the transmitted and received signals are typically mutually independent signals.

[0048] Transmission system 1-10 includes data source 1-2 of transmission system 1-10 is used to modulate transmitter 1-4. Antenna 1-5 applies the modulated signal through forward channel 1-16 to the sensor 1-14. Typically in RFID applications the transmitter 1-4 and the data source 1-2 form the interrogator or the reader in RFID networks. Data source 1-2 is used by the reader to embed an address and/or command sequence to the device such as RFID tag 1-14. In backscatter passive RFID tags, the transmitted signal may also embed a sinusoidal signal with a continuous waveform (CW), which may be used to supply power to passive RFID tag. RFID tag 1-14 may then respond back with a data sequence, based on the received command, through the air which is illustrated as the Return Channel 1-18. The main function of the receiver system 1-12 is to detect the data transmitted from the sensor 1-14, in presence of various distortions encountered in the return channel 1-18 such as multi-path and/or natural and man-made interference. Receiver system includes receiving antenna 1-7 which applies the signal received from RFID tag 1-14 to receiver 1-6. The detected data from receiver 1-6 may then be consumed by the user 1-8. In RFID applications the data user is the reader which passes the data to a higher layer protocol for interpretation of the received packet. For passive RFID tags, transmission system 1-10 and receiver system 1-12 may be referred to as "reader / interrogator" 1-13.

[0049] The underlying transmitter receiver pair, reader/interrogator 1-13, is shown in Fig. 1. The signal is transmitted over a communication channel with the impulse response $h(t)$ and corrupted with additive white Gaussian noise (AWGN) $n(t)$, the received signal $y(t)$ is modeled as:

$$y(t) = x(t) * h(t) + n(t) \quad (1)$$

where '*' represents the convolution operation.

[0050] Referring now to Fig. 2, an end-to-end communication system physical block diagram model 2-1 for a sensory signal is shown in Fig. 2a and includes data source 2-2 which feeds the modulator in the transmitter 2-4. This signal is applied via forward channel 2-6 to sensor 2-8. Only in the case when the transmitted signal from sensor 2-8 is a partially amplified version of the original signal, the impulse responses is the composite impulse response of the forward and return channel, i.e. $h_f(t) * h_r(t)$. In passive RFID applications, typically the tag may only use the signal from the reader to power itself. The return signal from the tag uses the backscatter modulation to modulate the electronic product code or a response back to the reader, in which case the channel impulse response is only limited to the return channel transfer function 2-10. The receiver 2-11 detects the incoming bit stream and outputs it to the user data 2-12.

[0051] In discrete time domain, we represent the sampled version of this complex received signal at time n as for the k^{th} packet or frame as an N -dimensional vector,

$$\mathbf{y}_k = H_k \mathbf{x}_k + \mathbf{n}_k \quad (2)$$

[0052] Here \mathbf{y}_k denotes the received complex vector with dimension N obtained from uniform sampling of the received signal complex signal (after down-conversion) as $y(nT_s)$, where T_s denotes sampling interval, and the aggregate channel transfer function represented as

$$H = \begin{pmatrix} h_1 & 0 & \cdots & 0 \\ 0 & h_1 & h_2 & \cdots \\ \vdots & 0 & \ddots & \vdots \\ 0 & 0 & 0 & h_1 \end{pmatrix} \quad (3)$$

[0053] Channel response matrix H may be real-or-complex valued constant, or belong to certain class of randomly distributed functions to model in-door or out-door multi-path channel response.

[0054] The sequence error probability may be minimized, which is equivalent to maximizing the a posteriori error probability conditioned on the sequence of observation. The estimated transmitted symbols are:

$$\hat{a}_n = \arg \max_{a_n \in \Psi} P(a_n | \mathbf{y}) \quad (4)$$

where, Ψ represents the input symbol alphabet.

By applying Bayes rule we have

$$P(a_k = \alpha | \mathbf{y}) = \sum_{\forall \mathbf{a} \ni a_k = \alpha} \frac{P(\mathbf{y} | \mathbf{a}) P(\mathbf{a})}{P(\mathbf{y})}. \quad (5)$$

If $\Psi = \{0, 1\}$ then let log likelihood ratio

$$\Lambda_1(a_n) = \log \frac{\Pr(a_n = 1 | \mathbf{y}_k)}{\Pr(a_n = 0 | \mathbf{y}_k)}. \quad (6)$$

Using Bayes formula and eliminating $\Pr(\mathbf{y})$, we obtain reliability or "extrinsic" information

$$\Lambda_1(a_n) = \lambda_1(a_n) + \lambda_2(a_n), \quad (7)$$

where $\lambda_1(a_n) = \log \frac{\Pr(\mathbf{y} | a_n = 1)}{\Pr(\mathbf{y} | a_n = 0)}$ represents the "extrinsic information" and

$\lambda_2(a_n) = \log \frac{\Pr(a_n = 1)}{\Pr(a_n = 0)}$ represents a priori log likelihood ratio (LLR) values. The sequence

$\lambda_1(a_n)$ is calculated in each iteration, and is the function of soft metric calculation block 4-8 shown in Fig. 4. In a SISO decoder, such as decoder 4-2 shown in Fig. 4, the a posteriori probability of each transmitted symbol may be computed and then subtracted from the reliability information to remove the influence of a priori information. The extrinsic information may then be fed back (and de-interleaved if channel encoding is used) for metric calculations for the next iteration, where:

$$\lambda_2(a_n) = \Lambda_2(a_n) - \tilde{\lambda}_1(a_n) = \log \frac{\Pr(a_n = 1 | \mathbf{y})}{\Pr(a_n = 0 | \mathbf{y})} \quad (8)$$

where tilde (\sim) denote values from the last decoding state. In presence of unknown random phase and timing, it may be necessary to consider the input and output joint probability

distribution functions $\Pr(\mathbf{a}, \boldsymbol{\phi}, \boldsymbol{\tau} | \mathbf{y})$ in which the optimization problem formulated in equation (4) becomes

$$(\hat{a}_n, \hat{\phi}_n, \hat{\tau}_n) = \arg \max_{(a_n, \phi_n, \tau_n) \in \Psi} P(a_n, \phi_n, \tau_n | \mathbf{y}) \quad (8a)$$

where, Ψ represents set of all values that a_n, ϕ_n, τ_n can take.

[0055] Referring now to Fig. 2b, in theoretical model 2-30, the performance of the overall RFID system may be enhanced by applying a simple and novel channel coding to the user data. This coding technique may include the use of an outer code 2-19, the interleaver 2-18 and a single parity check code 2-16, defined latter which is used to drive the modulation encoder over the channel. As an example, the outer code may be a repetition code (simply taking the input data of size M and repeating it q times where $q > 1$). The input data of size M bits may be partitioned into N equal size subsequences each of size M/N. Each subsequence is copied (repeated) q times (for example say $q=3$) then permuted by non-identical interleavers each of size M/N, all repeated and permuted subsequences enter a single parity check (SPC) with Nq input and one output. The output sequence of SPC may be of size M/N. the call output sequence may be considered as a parity sequence. Note that for this example the interleaver 2-18 is plurality of interleavers that can be more than one. The N data subsequences and the parity sequence may then be multiplexed to generate a sequence of length $M+M/N$ that enters the modulator encoder namely FM0, Miller, or any other modulator encoder used or to be used in the RFID system. It must be noted that 2-19, 2-18 and 2-16 are optional in the event it is desired to attain a coding gain in RFID systems.

[0056] The SISO decoder shown may be considered to be a device that maps an input sequence \mathbf{a} to an output sequence \mathbf{c} based on a finite state machine. If the coding scheme of 2-19, 2-18 and 2-16 is employed the SISO decoder will be designed to account for the outer code 2-19, interleaver 2-18, single parity code 2-16 and modulation encoder 2-14 when modeling the FSM for data encoder. The SISO decoder is embedded in the receiver 2-28. The outer code 2-19, the interleaver 2-18 and the single parity code 2-16 constitute a channel coding scheme that further take advantage of SISO decoder for the receiver realization in 2-28. A possible method of the channel coding technique for RFID applications is to apply the channel coding method to the RFID tag's identifier prior to writing into its memory, for passive

RFID tags types that are written only once and read many times. In the case of write and read many times RFID tags, the encoder (that is 2-19, 2-18 and 2-16) can be implemented in the tag, or the reader can pre-encode the desired stored information when writing into the tag. When the information is retrieved from the tag, that is when the reader reads the tag, the RFID tag transmits the stored information through channel 2-10 back to the reader. The coding gain is realized in this case by virtue of the structure of the stored information in the tag.

[0057] In addition, the SISO decoder may jointly estimate the state of the channel, random phase modeled as a complex multiplier in combiner 2-24. Timing offset, inherently present in any receiver subsystem and particularly in wireless systems, may be modeled in timing offset 2-26, with multi-path propagation characteristics. For channel model 2-22, a finite state machine may be used to represent the channel with memory as shown in channel matrix in equation (3).

[0058] Referring now to Fig. 3, a SISO decoder such as SISO decoder 3-2 can be viewed as a four port device. The input to the SISO decoder 3-2 is the joint probability of channel output 3-10 and transmitted symbol sequence 3-8. The output of SISO decoder 3-2 is the joint probability of channel output 3-4 and transmitted symbol sequence 3-6. The input symbol $\mathbf{a} = (a_k)$ with $k \in \aleph$ (\aleph is the set of integers) drawn from a finite alphabet

$A = \{\tilde{a}_1, \tilde{a}_2, \dots, \tilde{a}_N\}$ with a-priori probability $\Pr(\mathbf{a})$. Let $\mathbf{c} = (c_k)$ and $k \in \aleph$ is the sequence of output drawn from alphabet $C = \{\tilde{c}_1, \tilde{c}_2, \dots, \tilde{c}_N\}$ with a priori probability $\Pr(\mathbf{c})$. The SISO decoder 3-2 accepts at the input the sequence of probability distributions and outputs the sequences of probability distributions, namely: the input probabilities $P_k(a; I)$ in 3-8, $P_k(c; I)$ 3-8 3-10 and output probabilities $P_k(a; O)$ 3-6, $P_k(c; O)$ 3-4.

[0059] Referring now to Fig. 4, a SISO decoder 4-2 is illustrated for use when the proposed channel coding scheme is employed. The input to SISO decoder 4-2 is fed by computing equation (8), shown as the input to the de-interleaver 4-6. Input values of the De-interleaver 4-6 and the output of the interleaver 4-4 are the computed values from the last decoding iteration of the SISO decoder. The soft metric calculation may be performed by computing equation (7) in soft metric calculator 4-8 using the observed signal 4-9 and for a fixed phase value, timing and the channel state from step 4-10. The function and structure of the interleaver 4-4 and de-interleaver 4-6 is dictated by the repetition rate of the outer code

and discussed below. At the end of each iteration the SISO decoder 4-2 outputs $\Lambda_2(a_n)$ s multiple outputs which may then be subtracted from the output of 4-6 and fed to the interleaver block 4-4 to compute the input metric for the next iteration, used in 4-10 and 4-8. This process may be repeated until the SISO decoder 4-2 converges, at which time the extrinsic information is output for decoding the output stream.

[0060] Recursive computation of these input and output joint probability distribution functions, namely: $P_k(\alpha; I)$, $P_k(\alpha; 0)$, $P_k(c; 0)$ and $P_k(c; I)$ may be made possible by modeling the received symbols as output from a discrete-time finite-state Markov process source. The state of the source at time t is denoted by S_θ^t , and its output by Y . A state sequence of the source extending from time t to t' is made possible based on the underlying finite state machine model. The corresponding output forms a first order Markov chain, i.e.

$$\Pr(S_\theta^{t+1} | S_\theta^t, S_\theta^{t-1}, \dots, S_\theta^1) = \Pr(S_\theta^{t+1} | S_\theta^t) \quad (9)$$

[0061] Referring now to Fig. 5, for the purpose of phase sequence estimation and open loop tracking, the phase space may be quantized into Q^ϕ equally spaced intervals and denoted as:

$$\Theta^\phi = \left\{ 0, \frac{\pi}{M}, \frac{2\pi}{M}, \dots, \frac{(M-1)2\pi}{M} \right\} \quad (10)$$

[0062] The phase sequence can be modeled as a random walk around the unit circle, that is a Markov process: $\phi_n = \phi_{n-1} + \Delta\phi \bmod 2\pi$, where $\phi_n \in \Theta^\phi$ and $\Delta\phi$ can be modeled as discrete random variable taking values in the quantized phase space from a known probability density function (i.e. quantized Gaussian, Tikhanov or etc.). The probability of such a phase transition may be denoted as p_{ij} .

[0063] The M distinct states of the Markov source are indexed by the integer m , $m = 0, 1, \dots, (M-1)$ with probability transition matrix:

$$\mathbf{P} = \begin{pmatrix} p_{11} & p_{12} & \cdots & p_{1M} \\ p_{21} & p_{22} & & \vdots \\ \vdots & & \ddots & \\ p_{M1} & p_{M2} & & p_{MM} \end{pmatrix} \quad (11)$$

Where $\sum_{i=1}^M p_{ij} = 1$ and $p_{ij} = p_{ji}$, i.e. matrix is symmetric and doubly Markov.

[0064] Referring now to Fig. 6, the symbol duration Q^r may be quantized into equally spaced intervals for time and synchronization. The timing space may be represented as:

$$\Theta^r = \{\tau, \pm 2\tau, \pm 3\tau, \dots\} \quad (12)$$

Let: $\Upsilon = \left\{ \bigcup_{i=1}^V (t \in [nT_{sym} \pm i\tau, (n+1)T_{sym} \pm (i+1)\tau]) \right\}$ represent the ensemble of all possible symbol timing intervals where V is the cardinality of the set of i such that

$|nT_{sym} \pm i\tau| < \frac{(nT_{sym} - (n+1)T_{sym})}{2}$. Then J represents any member of set Υ , i.e. $J \in \Upsilon$.

[0065] For assigning the transition probability matrix \mathbf{P} for phase tracking, it is possible to use the classical theory of phased-lock-loops where distribution of state phase error and clock stability from the oscillator can be computed or estimated. Thus matrix \mathbf{P} and can be pre-computed based on a single transition probability from one timing state to another. For assigning the transition probability matrix \mathbf{P} for symbol timing, a geometric distribution can

also be used (i.e. $\frac{\partial}{M^n}$ where ∂ is a constant such that $\sum_{n=1}^M \frac{\partial}{M^n} = 1$).

[0066] Assuming the channel impulse response length of L , at each time instance $k = 1, 2, \dots, N$ the state of the channel is a random variable with the property of the memory present in the system that, given S_k , the state S_{k+1} can only assume one of two values corresponding to a +1 or -1 being fed into the tapped delay line at time k . Thus, given a binary input alphabet $\{+1, -1\}$ the channel can be in one of 2^L states ri , $i = 1, 2, \dots, 2^L$; corresponding to the $2^L 2L$ different possible contents of the delay elements. This set may be denoted by Θ^h the set

of possible states. Additionally, let Θ^e represent the set of possible states of modulation encoder or line encoder or differential encoder.

[0067] Let the product space

$$\Omega = \Theta^e \otimes \Theta^h \otimes \Theta^r \otimes \Theta^h \quad (13)$$

represent the space of all possible states of the system, where \otimes denotes the Cartesian product and N the cardinality of Ω .

[0068] Referring now to Fig. 7, the possible evolution of states $S^n \in \Omega$ can thus be described in form of a trellis diagram. An example of such a trellis structure for a 16-state trellis diagram is illustrated in Fig. 7, where there are 16 transitions from each state of the trellis to the other.

[0069] The state transitions of the Markov source are governed by the transition probabilities. In which case for the forward and backward log probabilities of the SISO decoder may be defined as follows:

$$\begin{aligned} \alpha_k(S) &= \underset{e: S^n(e) \in \Omega}{\text{Max}} \left\{ \begin{array}{l} \alpha_{k-1}(S^s(e)) + \Pi_k(a(e); I) + \\ \Pi_k(c(e); I) + \Pi_k(c(e); O) \end{array} \right\} \\ \beta_k(S) &= \underset{e: S^n(e) \in \Omega}{\text{Max}} \left\{ \begin{array}{l} \beta_{k-1}(S^E(e)) + \Pi_{k+1}(a(e); I) + \\ \Pi_{k+1}(c(e); I) + \Pi_k(c(e); O) \end{array} \right\} \end{aligned} \quad (14)$$

$\forall k = 1, \dots, N$, where

$$\begin{aligned} \Pi_k(c; I) &\square \log(\mathbf{P}_k(c; I)), & \Pi_k(a; I) &\square \log(\mathbf{P}_k(a; I)) \\ \Pi_k(c; O) &\square \log(\mathbf{P}_k(c; O)), & \Pi_k(a; O) &\square \log(\mathbf{P}_k(a; O)) \end{aligned} \quad (15)$$

[0070] This maximization is over all the edges e connected to a state selected from the ensemble of all possible states connected in the trellis. Equation (14) in log domain can be represented as:

$$\begin{aligned}\Pi_k(c;0) &= \text{Max}_{e:c(e)=c} \left\{ \alpha_{k-1}(S^s(e)) + \Pi_k(a(e);I) + \beta_k(S^E(e)) \right\} + h_c \\ \Pi_k(\alpha;0) &= \text{Max}_{e:a(e)=a} \left\{ \alpha_{k-1}(S^s(e)) + \Pi_k(c(e);I) + \beta_k(S^E(e)) \right\} + h_u\end{aligned}\quad (16)$$

and initial values

$$\alpha_0(S) = \begin{cases} 0 & s = S_0 \\ -\infty & \text{Otherwise} \end{cases}, \quad \beta_n(S) = \begin{cases} 0 & s = S_n \\ -\infty & \text{Otherwise} \end{cases}\quad (17)$$

[0071] The quantities h_c and h_u are normalization constants to limit the range of the numerical values of α and β . The set of states $\Xi = \{S_1, S_2, \dots, S_n\}$ and edges

$E = \{e_1, e_2, \dots, e_k\}$ represent all possible transitions between the trellis states. $S^s(e)$ denotes all the starting states for the transition $e \in E$ to the ending state $S^E(e)$ with input symbol $a(e)$ corresponding to the output symbol $c(e)$.

[0072] Referring now to Fig. 8a, the operation for computation of α_k and β_k for the binary case is illustrated in Fig. 8a, i.e. two transitions to traverse from state S_k to S_{k+1} . In each iteration, the forward and backward log probabilities may be computed by considering the Trellis structure in Fig. 8a, that is

$$\begin{aligned}\alpha_k &= \max(\alpha_i + m_{ik}, \alpha_j + m_{jk}) \\ \beta_i &= \max(\beta_k + m_{ik}, \beta_l + m_{il})\end{aligned}\quad (18)$$

[0073] In order to compute the extrinsic information for each bit as shown in Fig. 8b, the input bit sequence may simply be written as:

$$\Pi_k(\alpha;0) = \text{Max}_{\substack{\text{All edges} \\ \rightarrow a=1}} \{\alpha + m + \beta\} - \text{Max}_{\substack{\text{All edges} \\ \rightarrow a=0}} \{\alpha + m + \beta\}\quad (19)$$

and the extrinsic for the output code is:

$$\Pi_k(c;0) = \text{Max}_{\substack{\text{All edges} \\ \rightarrow c=1}} \{\alpha + m + \beta\} - \text{Max}_{\substack{\text{All edges} \\ \rightarrow c=0}} \{\alpha + m + \beta\}\quad (20)$$

The branch metric m is computed as:

$$m = \frac{a\Pi(\alpha; I) + c_1\Pi(c_1; I) + \dots + c_r\Pi(c_r; I) + \dots}{\Pi(c_1; \phi) + \Pi(c_1; \tau)} \quad (21)$$

where r represents the index to the selected element of channel symbol output of c .

[0074] This establishes the equivalency of the SISO decoder as shown in Fig. 3 and computation of equations (18) through (21).

[0075] Referring now to Fig. 9a, the structure of Single Parity Check (SPC) code is given. The input stream of size M is de-multiplexed in demux 9-6 into blocks of N subsequences of length M/N . Each subsequences optionally are permuted with N interleavers each of size M/N prior to entering MUX 9-8. These “optional” interleavers (e.g., tags) together with interleavers prior to single parity check code can be used to provide security for RFID system. This method provides a highly secure RFID system The N data subsequences as described before are repeated q times and permuted with Nq interleavers. The output of the interleaved blocks are all exclusive OR’ed together in combiner 9-10 to form a single parity check sequence of length M/N which is multiplexed in MUX 9-2 to form a serial output stream. The outputs of multiplexer 9-2 are then fed into the modulation encoder 9-4 (which may be FM0 or Miller code). The interleaver blocks 9-8 in this figure each are designed to preserve the Hamming weight of the input vector at the output of interleaver. The repetition q and the code rate defined in this case as $N/(N+1)$ are design parameters chosen for desired length of the output sequence and coding gain. Presently RFID tag identifiers range anywhere from 24-bits to 2048-bits vectors, that is the output block size of the encoder. The input data U , the input to de-multiplexer 9-6, once encoded forms a vector of length $M+M/N$.

[0076] Referring now to Fig. 9b, the structure of Single Parity Check (SPC) decoder is illustrated as an RFID channel SIS) Decoder. The soft output stream of size $M+M/N$ from SISO modulation decoder is de-multiplexed in demux 9b-6 into blocks of $N+1$ subsequences of length M/N . The first N subsequences deinterleaved through the “optional” N deinterleavers each of size M/N which were used to provide security for RFID system. Knowing these permutation represent secure keys for RFID system, the N soft data subsequences after the “optional” deinterleavers may be repeated q times and permuted with Nq interleavers. The output of the interleaved blocks are all collected together with soft outputs from DEMUX 9b-2b for parity bits enter to the SISO single parity check decoder in

SISO decoder 9b-10 to generate soft outputs. The $N+1$ soft output subsequences from SISO single parity check decoder each of length M/N enters Nq deinterleavers 9b-8b. The soft output of deinterleavers enters the SISO repetition decoder. The output of the repetition decoder enter the “optional” interleavers. The output of the “optional” interleaver, together with soft output for parity bits from SISO SPC, are multiplexed in MUX 9b-2b to form a serial output stream. The outputs of multiplexer 9b-2b are then fed into the SISO modulation decoder 9b-4 (e.g. FM0 or Miller decoder). This process goes through several iterations. The output and input of SISO for repetition decoder are summed to provide reliability for input subsequences data streams. The N subsequence streams are input to de-multiplexer 9b-6. The output of the demultiplexed processes are input to hard decision device 9-16 to generate decoded bit stream U . The detailed operation of SISO decoder for repetition code is shown in Fig. 9c in steps 9c-10, 9c-12, 9c-14, 9c-16 and 9c-18. The detailed operation of SISO decoder for SPC is shown in Fig. 9d in steps 9d-10, 9d-12, 9d-14 and 9p-16.

[0077] Referring now to Fig. 10, coherent SISO receiver 10-10 is disclosed. In this case the extrinsic and intrinsic and branch metrics respectively are represented by the set of equations in equations (18) to (21). Callouts indicate the function of each processing subsystem, the analyzer and equalizer block diagram is shown in 10-6, the estimation block in 10-2 and the detector in 10-4. The input signal may have traversed airspace or a wired infrastructure to reach the receiver, there is no limitation in terms of the transport mechanism into the system. The received signal is de-multiplexed into a parallel stream into a size of the packet or frame used in the communication system. The received signal is then fed to the channel equalizer and interference canceller filter bank in input 10-8. This signal is the rotated via a vector phase rotation (vector complex multiplication) 10-10. The output of 10-10 is used to compute the soft metric values which then feeds the SISO decoder 10-14.

[0078] The theory of operation of a coherent SISO decoder may be described as follows: the observed vector 10-50 y is obtained from serial to parallel conversion 10-52 of the received signal to form the vector 10-50. The size M indicated in 10-50 is chosen as the length of the samples in the received packet, or for practical consideration, a convenient length for the desired hardware complexity. The signal 10-50 is fed to channel equalizer 10-16 which is composed of a modulated filter bank. The filter bank transfer function is selected for typical deployment scenario to match the propagation environment and use case scenario. The signal

from channel equalizer 10-16 is rotated in phase by rotator 10-10 and fed into the correlator and soft metric estimation block 10-12. When channel coding is used, the output of estimation block 10-12 is subtracted from the output of the interleaver as discussed above with regard to Fig. 4 and processing in blocks 4-6 and 4-4. The de-interleaver 10-24 and interleaver block 10-26 are matched to the channel encoder interleaver block used for encoding the data in 9-8, when an optional mode when used. The signal from the de-interleaver 10-24 is fed into the SISO receiver 10-14. After each iteration, the output of the SISO decoder 10-14 is input to the interleaver 10-26 whose output is fed into the channel estimation block 10-36 and to the metric computation block 10-12. The channel estimation block 10-36 decodes the channel impulse response in equation (3) and is used to update the filter bank coefficients in the channel equalizer and interference excision block 10-16. The received vector \mathbf{y} 10-50 (also denoted as \mathbf{Y}_k where the index k denotes the iteration index in 10-30) is also fed into clocks 10-34, 10-28, 10-39 and 10-37. In delay 10-34, the signal is delayed to match the latency required by each iteration as the input data for the channel estimation block. In 10-37 the observed vector is used to detect the preamble sequence and initialize the symbol timing block 10-39. The symbol timing block 10-39 is updated in each iteration from 10-62 which is the same signal as 10-60, which is the output of the SISO decoder. The output of the symbol timing block 10-39 produces a square wave output 10-35 which is used a reference symbol clock source throughout the system. If there is a residual carrier in the waveform, as in some RFID standards, tracking loop 10-46 is used to extract the CW and compute the phase offset from the ideal carrier frequency in carrier offset block 10-38. If a subcarrier is used, as in some RFID standards, the output of carrier offset block 10-38 is further enhanced by estimating an additional phase offset term from the subcarrier phase, by performing fine frequency tracking in 10-42 and by computing the phase offset in phase offset block 10-44. The frequency estimate from fine frequency block 10-42 may also be fed back to FFT 10-18 to update the spectral estimate of the signal for the next iteration.

[0079] In an optional mode, it may be desirable to additionally also perform frequency domain equalization in each iteration of the SISO decoder as shown in detector 10-4. This functionality may be enabled in the presence of fast frequency fading channels in which the signal may suffer fast fades during a single symbol interval. In an RFID system, these may be

caused by conveyor belts, fast moving tunnel highways or moving vehicles. In this case the estimated impulse response state may be fed to the equalizer coefficient estimation block that feeds the FFT block to compensate for fading and multipath effects.

[0080] Referring now to Fig. 11, non-coherent SISO receiver 11-10 is disclosed. The operation of all the computational blocks, namely, 11-18, 11-20, 11-22, 11-16, 11-10, 11-46, 11-44, 11-42, 11-40, 11-38, 11-36, 11-34, 11-37, 11-39, 11-54, 11-46, 11-40, 11-60, 11-62, are the same as in 10-18, 10-20, 10-22, 10-16, 10-10, 10-46, 10-44, 10-42, 10-40, 10-38, 10-36, 10-34, 10-62, 10-37 and 10-39. The channel equalizer and interference canceller 11-16 is similar to the coherent block 10-16, except the input channel estimates may now be based on the non-coherent estimation block for which the equations are presented below. The key distinction between the coherent and non-coherent versions of the receiver architecture is in the computation of extrinsic information for branch metric computation, and the amount of phase rotation imposed in phase rotator 11-10. The channel equalizer block 11-16 is similar to the coherent case with the exception that estimates for the channel coefficients are derived from the non-coherent SISO detector. The SISO decoder 11-14 uses a similar trellis to that of the coherent case, except the branch metrics computed in 11-12 are based on non-coherent signal detection theory which is essentially phase invariant in presence of random or unknown phase. In each iteration in block 11-12, equation (33) is computed and/or updated based on the previous iteration of the extrinsic information, that is the output from the SISO decoder's last iteration via equation (21).

[0081] In a non-coherent case, the received signal (in absence of multipath the symbol c_k is denoted simply by x_k) may be modeled with random or unknown phase as:

$$\mathbf{y}_k = A\mathbf{x}_k e^{j\phi} + \mathbf{n}_k \quad (22)$$

[0082] In an AWGN channel with n_k , that is complex zero mean Gaussian noise with variance σ^2 per dimension, the observed vector's probability distribution function conditioned on a known phase and the transmitted sequence of N symbols is:

$$P(\mathbf{y}|\mathbf{x}, \phi) = o \cdot e^{-\frac{1}{\sigma^2} \sum_{n=1}^N |y_n - Ax_n e^{j\phi}|^2} \quad (23)$$

Where o is a constant and σ is the variance of the noise. After some algebraic manipulation we can write (23) as

$$P(\mathbf{y}|\mathbf{x}, \boldsymbol{\varphi}) = o. e^{-\frac{A^2}{2\sigma^2} \sum_{n=1}^N |x_n|^2} e^{\frac{A}{\sigma^2} \text{Re} \left(\sum_{n=1}^N y_n^* x_n e^{j\phi} \right)} \quad (24)$$

Averaging (24) over the uniformly distributed phase over $(0, 2\pi)$ yields:

$$P(\mathbf{y}|\mathbf{x}) = o'. e^{-\frac{A^2}{\sigma^2} \sum_{n=1}^N |x_n|^2} I_0 \left(\frac{A}{\sigma^2} \left| \sum_{n=1}^N y_n^* x_n \right| \right) \quad (25)$$

where $I_0(\cdot)$ represents the modified zero-th order Bessel function.

Recall

$$P(x_i = x|\mathbf{y}) = \frac{1}{P(\mathbf{y})} \sum_{\mathbf{x}: x_i=x} P(\mathbf{y}|\mathbf{x}) \prod_l P(x_l) \quad (26)$$

From (25),

$$\frac{P(x_i = x|\mathbf{y})}{P(x_i = x)} = o'. \sum_{\mathbf{x}: x_i=x} \left(e^{-\frac{A^2}{2\sigma^2} \sum_{n=1}^N |x_n|^2} \times \right. \\ \left. I_0 \left(\frac{A}{\sigma^2} \left| \sum_{n=1}^N y_n^* x_n \right| \right) \right) \prod_{l \neq i} P(x_l) \quad (27)$$

Or equivalently, the extrinsic metric may be approximated in equation (27) as

$$\prod_l (x_l = x, 0) \approx \max_{\mathbf{x}: x_i=x} \left\{ \begin{array}{l} -\frac{A^2}{2\sigma^2} \sum_{n=1}^N |x_n|^2 + \\ \frac{A}{\sigma^2} \left| \sum_{n=1}^N y_n^* x_n \right| + \\ \sum_{l \neq i} \ln p(x_l) \end{array} \right\} \quad (28)$$

For the special case when x_n takes values +1 and -1, then the term $-\frac{A^2}{2\sigma^2} \sum_{n=1}^N |x_n|^2$ can be ignored, since $|x_n|$ is constant.

[0083] Next consider a Rayleigh fading channel model, where in equation (22), the magnitude A is Rayleigh distributed and the phase is uniformly distributed over $(0, 2\pi)$ interval. The observed vector's probability distribution function conditioned on a known amplitude and the transmitted sequence of symbols is:

$$P(\mathbf{y}|\mathbf{x}, A) = \prod_{n=1}^N e^{-\frac{1}{2\sigma^2}|y_n|^2} e^{-\frac{A^2}{2\sigma^2}\sum_{n=1}^N |x_n|^2} e^{\frac{2}{2\sigma^2} \text{Re}\left(\sum_{n=1}^N y_n^* x_n\right)} \quad (29)$$

Lets assume that the average power of A is σ_f^2 and taking the expectation with respect to complex random variable A results in $P(\mathbf{y}|\mathbf{x}) = E_A\{P(\mathbf{y}|\mathbf{x}, A)\}$.

$$P(\mathbf{y}|\mathbf{x}) = \iint \prod_{n=1}^N e^{-\frac{1}{2}\left[\frac{\sum_{n=1}^N |x_n|^2}{\sigma^2} + \frac{1}{\sigma_f^2} |A|^2 + \frac{2}{\sigma^2} \text{Re}\left(\sum_{n=1}^N y_n^* x_n\right)\right]} dA \quad (30)$$

which can be integrated to:

$$P(\mathbf{y}|\mathbf{x}) = c'' \frac{1}{\left[\frac{\sum_{n=1}^N |x_n|^2}{\sigma^2} + \frac{1}{\sigma_f^2}\right]} e^{-\frac{1}{2}\left[\frac{1}{\sigma^2} \sum_{n=1}^N y_n^* x_n\right]^2} \quad (31)$$

For obtaining the extrinsic information, from equation (31), the following equation applies

$$\frac{P(x_i = x | \mathbf{y})}{P(x_i = x)} = e^{-\frac{1}{2} \left[\frac{1}{\sigma^2} \sum_{n=1}^N y_n^* x_n \right]^2} e^{-\frac{\sum_{n=1}^N |x_n|^2}{\sigma^2} + \frac{1}{\sigma_f^2}} \prod_{l \neq i} P(x_l) \quad (32)$$

which after some algebraic manipulation can be simplified to:

$$\prod_i(x_i, 0) = \text{Max}_{\mathbf{x}: x_i = x} \left\{ \begin{aligned} & -\ln \left[\frac{\sum_{n=1}^N |x_n|^2}{\sigma^2} + \frac{1}{\sigma_f^2} \right] + \\ & \frac{1}{2} \frac{1}{\sigma^2} \left| \sum_{n=1}^N y_n^* x_n \right|^2 \\ & \frac{1}{2} \left[\frac{\sum_{n=1}^N |x_n|^2}{\sigma^2} + \frac{1}{\sigma_f^2} \right] \\ & + \sum_{l \neq i} \ln P(x_l) \end{aligned} \right\} \quad (33)$$

It should be noted that $\prod_l(x_l, 0)$ is defined as $\ln p(x_l)$

[0084] Referring now to Figs 12a and 12b, and in particular Fig. 12b, the operation of an iterative cascaded SISO receiver, with non-coherent and coherent models as described earlier, may be as follows:

[0085] Received vector \mathbf{y}_k may be initially iterated in the non-coherent SISO receiver until the stopping rule for minimizing the sequence error probability is satisfied. The output of the non-coherent receiver for the estimated symbol sequence, timing, phase and channel response may then be used for the initial estimate of these sequences in the subsequent coherent SISO receiver. The SISO decoder of 12-14 and 12-2 are essentially same decoders, except the SISO decoder 12-12 receives its input branch metrics from extrinsic information from the non-coherent SISO decoder 12-6.

[0086] Coherent SISO receiver system 12-10 is shown in Fig. 12a in which a received signal is applied to branch metric generator 12-12 which computes the branch metric m_{ik} in equation (18). These branch metrics are computed for each transition for each state of the trellis from one-to-the-other. The branch metrics are input to coherent SISO decoder 12-14. After a sufficient number of iterations (indicated by loop 12-16) in effect minimizing the sequence error probability in each iteration, the decoder slightly improves and reduces the

error probability. The switch 12-18 may driven by a fixed or dynamic rule. Typically after five to ten iterations, the SISO decoder output can be sampled and hard quantized. An alternative approach would be to monitor the dynamic range of the extrinsic values and when the values reach steady state (no longer changing or arbitrarily small change), the SISO decoder may be stopped and the output may be hard limited in block 12-20 and decoded .

[0087] Referring now to Fig. 12b, cascaded non-coherent and coherent SISO receiver system 12-22 is depicted in which the received signal is used by the branch metric generator 12-8 to output the metric values to the non-coherent SISO decoder 12-6. The difference between 12-2 and 12-8 is that the branch metric values for the non-coherent case are computed by considering the distribution of phase to be random, where in the coherent case the phase is assumed to be known . After a sufficient number of iterations (as shown by loop 12-24), the output of the non-coherent SISO decoder 12-6 is sampled by sample switch 12-26 and applied to coherent SISO decoder 12-12. After a sufficient number of iterations (as shown by sample loop 12-28), the output is applied by sample switch 12-30 to hard limiter 12-4 and then provided to the data user which in RFID application is the protocol layer-2 embedded in the reader system. An option for the stopping rule to close the switches 12-26, 12-28 and 12-30 is to monitor the rate of growth of the accumulated forward and backward metrics in equation (14) in each SISO decoder, and then stop the iteration when the difference between successive iterations is arbitrarily small for all the states in the Trellis.

[0088] Referring now to Fig. 13a, an implementation of RFID system 13-10 is shown in which plurality of inventory items, such as items 13-7, each of which may include a passive RFID tags 13-6. The reader/interrogator 13-1 emanates a signal to RFID tags 13-6 to respond with their respective identification code referred to as "electronic product codes" (EPC). The RFID tags 13-6 subsequently respond to signals generated by reader 13-1 by backscattering the received signal with their respective EPCs. The signal may be corrupted by multipath 13-4 from the flooring the walls and moving and fixed obstacles 13-8.

[0089] Referring now to Fig. 13b, reader/interrogator 13-1 includes transmitter-antenna subsystem 13-24 which is modulated by data from data source system 13-36 applied to modulation encoder 13-15 and transmits encoded RF signals to RFID tags 13-7. Alternatively, outer coder 13-28, interleaver 13-48 and/or single parity coder 13-50 may be inserted between data source 13-36 and encoder 13-52 in appropriate implementations.

[0090] Reader interrogator 13-1 also includes receiver 13-28 which receives reflected signals from RFID tags 7 and applies them to receiver system 13-30 for detection and decoding. The output of receiver system 13-30 provides data to a system user. Various obstacles, including sources of interference and multi-path reflection such as stationary and moving objects 13-8 may be in the path of the transmitted and/or received signals.

[0091] System 13-10 may, for example, be deployed in a department store in which items in cases of items with RFID tags 13-6 are displayed for sale. Moving and stationary objects 13-8 may represent shoppers and store personnel moving during the day across the transmission and reception paths as well as relatively stationary objects such as one or more potential reflectors, e.g. including advertising displays or other racks of may be moved or changed on a less frequent basis. System 13-10 may be deployed in order to keep track of inventory items, for example, to detect and prevent attempted shoplifting and/or for other reasons related to inventory control by providing data from reader interrogator 13-1 to a user.

[0092] Data source system 13-12 includes data source 13-36 which provides a command or an EPC to the RFID tag 13-7. Channel coding techniques may be used to improve the overall system performance. In the event channel coding is employed, the electronic product code stored in RFID tag 7 is used as the input. The data source may embed the Electronic Product Code (EPC) in pre-coded format by using outer coder 13-38, interleaver 13-48 and single parity coder 13-50 at the time that the stored data is written into the RFID tag. In that event, the model of data source 13-36 simplifies to a table look-up for EPC which, in the case of passive RFID tags, is backscattered (or transmitted) to the interrogator or the RFID reader. It is also noted that it is possible to compress the EPC code in the interrogator prior to application of channel coding, using simple hashing method to decrease the length of the information sequence. Thus, the additional storage in the RFID tag is used to store the resulting parity bits. For example, for a 32-bit EPC code, the sequence can be hashed into a 16-bit code by the interrogator in which case the effective coding rate would be rate one-half, and the remaining 16-bit is used as a parity check sequence. The channel coding method may be used for protection against channel error. The code shown in Fig. 9 is a repetition code in which each data bit is repeated with a fixed number of multiplicity. The number of repetitions of each input bit is a design parameter which determines the overall coding rate of the system. The interleaver 13-48 serves to permutate the encoded data from the outer code output 13-38,

such that the Hamming distance of the input sequence is preserved and the output is applied to single parity coder 13-50 and described earlier in Fig. 9. The output of which is applied to modulation encoder 13-52. The modulator may use various modulation techniques and waveforms defined by various RFID tag or sensory standardization bodies. System 13-10 is applicable to any modulation technique or waveform. That is, modulation encoder 13-52 can be amplitude shift keying (ASK), on-off keying (OOK), frequency modulation (FM) and other modulation schemes without any loss of generality in applying the receiver subsystem in 13-30.

[0093] RFID tags 13-7 operate to backscatter or actively transmit the embedded information sequence to the reader or the interrogator to produce the signals received in equation (2). Stationary and moving obstacles 13-8 may cause interference between the signals reflected by one or more of the RFID tags 13-7. The signals received by receiver 13-30 may therefore include channel interference, multi-path reflections and other effects which make detection and discrimination between RFID tags 13-7 difficult with very low signal levels. Additional anomalies may also be present in the communication channel. In an in-door environment such as warehouses, factories and malls substantial scattering due multipath and man-made interference (e.g. drill noise, cordless phones) or natural interferences (e.g. ceiling lighting) may also be present. In an outdoor environment interference and multipath effects may also be present in addition to signal blockage due to foliage and weather effects due to humidity or rain. These channel anomalies and interferences may all be handled by receiver system 13-30.

[0094] Receiver system 13-30 serves to detect and discriminate between RFID tags 13-7 by taking advantage of SISO decoding proposed herein. It is assumed that latency in SISO decoding can be tolerated by the users of the system 13-10 or the processing time in system 13-10 is short for real or near real time detection of motion of individual RFID 13-7. That is, reader/interrogator 13-1 processes the signals received by receiver system 13-30 for a relatively long time and is able to distinguish between transmission channels from different RFID tags by learning the signal characteristics. Furthermore, in warehouse, factory and airport deployment scenarios the RFID tags may be moving at high velocity on conveyor belts or moving vehicles while being manipulated. Reader Interrogator 13-1 also compensates for effect of moving RFID tags on the characteristic of the received signal. That is the system 13-

10 can tolerate a high level of Doppler shift and still achieve high performance in detection of signals from RFID tags.

[0095] Receiver system 13-30 also provides a frequency signal to receiver 13-28 to adjust the transmitted frequency. This frequency adjustment provides a mechanism to both track and adopt the frequency channel used to read and write information into the RFID tag and also support optional waveforms which employ frequency hopping techniques as defined by RFID Standardization Bodies (e.g. ISO, EPC Global).

[0096] Receiver system 13-30 processes the received signals in channel equalizer and interference canceller 13-54 which is realized by a bank of adaptive linear phase filter banks with the objective of maximizing the received signal power and minimizing the effect of interference by excision. That is, the frequency response of the filter bank is designed to eliminate narrow band interference while maximizing the signal-to-noise ratios received from the RFID tag. The output of channel equalizer and interference canceller 13-56 is applied to rotator 13-58 which appropriately adjust the phase of the incoming signal in real-time to track the phase of the incoming signal and compensate for the effect of motion, Doppler and phase noise due to imperfection in the environment.

[0097] The output of rotator 13-56 is applied to SISO processor 13-58, which includes SISO decoder 13-60, and which serves to input into the soft metric calculator which calculates the intrinsic metric values associated with each transition from one state of trellis structure to the other state (or Bi-partite graph). The output of SISO processor 13-58 is applied to phase, channel and frequency estimator 13-62 which serves to provide an instantaneous phase and frequency estimate of the received signal based on the output of the SISO decoder.

[0098] One output of phase, channel and frequency estimator 13-62 is applied to rotator 13-56 and provides the reference for phase compensation of the received signal which may have been caused by motion or other anomalies. A second output of phase, channel and frequency estimator 13-62 is applied to channel equalizer and interference canceller 13-54 and provides the adaptation algorithm with the phase and frequency of variables used to compute the channel equalizer and interference canceller coefficients of the Finite Impulse Response Filter.

[0099] The output of user system 13-34 is formed by summing the extrinsic and intrinsic information and then hard quantizing the resulting sum. This value constitutes the detected bit

stream from the RFID tag. SISO decoder 13-60 in SISO processor 13-58 also includes soft metrics calculator 13-66, de-interleaver 13-64 and interleaver 13-67 when channel coding as discussed earlier is employed.

[00100] In operation of system 13-30, both fine and coarse motion of items 13-6 having RFID tags 13-6 can be accurately detected and observed because the SISO decoder in 13-60 simultaneously estimates the channel response, symbol timing and effectively performs open loop phase tracking.

[00101] Referring now to Figs. 14a and 14b, the FM0 and Miller codes can also be used in passive RFID applications. In FM0 encoder 1410, user data 14-22 is provided to x-or gate 14-18 the output of which is provided to bit mapper 14-16 as well as to simple delay circuit 14-23. The output of delay 14-23 may be provided as a second input to x-or gate 14-18 as well as to inverter 14-20, the output of which is applied to bit mapper 14-14. The two sequences from bit mappers 14-14 and 14-16 are respectively multiplexed into a single stream in multiplexer 14-12 and each repeated once in repeater 14-21 to provide output data 14-24 which is the FM0 encoded data for use by the modulator. FMO encoder 1410 may be used as a data source, such as data source 2-2 in Fig. 2 or data source 2-20 in Fig. 2b.

[00102] In Miller encoder 14-60, delay taps 14-44 and 14-36 are used. The combinatorial logic consists of three inverters 14-46, 14-50, 14-52, two or-gates 14-32 and 14-34, and three and-gates 14-42, 14-36 and 14-38. The output sequence of the combinatorial and delay logic is fed into the signal mapping blocks 14-56 and 14-58 which is multiplexed in 14-30 and repeated in 14-57 to form the output data 14-48 for Miller encoded data for use by the modulators.

[00103] Referring now to Fig. 15a, the technique for the coherent detection of FM0 or Miller encoded signal is depicted. The system consists of using the channel data 15-28 and integrating the signal over each symbol period during each half a symbol interval in integrate and dump 15-34 and de-multiplexing the real and imaginary part in demux 15-36 and forming the cross product in step 15-38, taking the real part in block 15-42, hard quantizing the output in quantizer 15-44 and mapping the data into ones and zeros from -1/+1 in data block 15-46. This is the coherent case.

[00104] Referring now to Fig. 15b, a similar operation is performed in non-coherent case in blocks 15-30, 15-32, 15-60, 15-62, 15-64 and 15-52 except only the real part of the signal is

used to form the cross product. The output of the non-coherent detector 15-66 and coherent detector is 15-48. N_s denotes the number of sample per symbol, i.e. $N_s = T_{sym} / T_s$ that is the ratio of the symbol time to sampling period.

[00105] Referring now to Fig. 15c, a block diagram of a multiple symbol detector is shown for the non-coherent detection case. Channel data 15-80 is applied to integrate and dump 15-80 and the real part is determined by block 15-76 and demultiplexed in demux 15-74. The output is applied to non-coherent multiple symbol detector 15-70 to provide output 15-72.

[00106] Referring now to Fig. 16, multiple symbol non-coherent detector (MSNNonCoh) for FM0 is disclosed. In this example, the non-coherent detection is done over a particular sequence of half symbol observations which starts from middle of data interval rather than beginning of data interval. In passive RFID systems, the presence of CW translates into having a DC component. The received signal with FM0 encoding at time i in presence of DC component is:

$$\begin{aligned} y_{1,i} &= (x_{1,i} + c)e^{j\phi} + n_{1,i} \\ y_{2,i} &= (x_{2,i} + c)e^{j\phi} + n_{2,i} \end{aligned} \quad i = k - N + 2, \dots, k + 1 \quad (33)$$

where c is a dc component, ϕ is carrier phase offset (or phase noise). Without loss of generality, it can be assumed that the phase error is constant over duration of a symbol and $n_{1,i}$ and $n_{2,i}$ zero mean complex Gaussian samples with variance σ^2 per dimension. First the dc value c at the receiver can be estimated as:

$$\hat{c} = \frac{1}{N} \left(\sum_{i=k-N+2}^{k+1} (y_{2,i-1} + y_{1,i}) \right) \quad (34)$$

The new observation can be defined as

$$\begin{aligned} r_{1,i} &= y_{1,i} - \hat{c} \\ r_{2,j} &= y_{2,j} - \hat{c} \end{aligned} \quad (35)$$

Next the Maximum Likelihood (ML) probability of the modified observation can be computed. The particular observations are:

$$r_{2,k-N+1}, r_{1,k-N+2}, r_{2,k-N+2}, r_{1,k-N+3}, \dots, r_{2,k}, r_{1,k+1}$$

The conditional probability function can be formulated as:

$$P(\mathbf{r} | \mathbf{x}, \phi) = \text{constant } e^{-\frac{1}{2\sigma^2} \sum_{i=k-N+2}^{k+1} \{r_{2,i-1}^2 x_{2,i-1}^2 e^{j\phi} + r_{1,i}^2 x_{1,i}^2 e^{j\phi}\}} \quad (36)$$

Averaging (36) over the carrier phase, the ML function can be approximated with

$$P(\mathbf{r} | \mathbf{x}) \approx I_0 \left(\frac{1}{2\sigma^2} \left| \sum_{i=k-N+2}^{k+1} \{r_{2,i-1} x_{2,i-1} + r_{1,i} x_{1,i}\} \right| \right) \quad (37)$$

Since the zero order modified Bessel function is a monotonic function, thus the required metric for the decision is:

$$\text{Metric} = \left| \sum_{i=k-N+2}^{k+1} (r_{2,i-1} x_{2,i-1} + r_{1,i} x_{1,i}) \right| \quad (38)$$

The key property of FM0 encoder output 14-24 for RFID application is

$$\begin{aligned} x_{2,i} &= d_i x_{2,i-1} \\ x_{1,i} &= -x_{2,i-1} \end{aligned} \quad (39)$$

Replacing (39) in (38) one gets:

$$\text{Metric} = \left| \sum_{i=k-N+2}^{k+1} (r_{2,i-1} - r_{1,i}) x_{2,i-1} \right| \quad (40)$$

or

$$(\hat{d}_k, \hat{d}_{k-1}, \dots, \hat{d}_{k-N}) = \arg \max_{d_k, d_{k-1}, \dots, d_{k-N+2}} \left| (r_{2,k-N+1} - r_{1,k-N+2}) + \sum_{i=k-N+3}^{k+1} (r_{2,i-1} - r_{1,i}) \prod_{j=k-N+2}^{i-1} d_j \right| \quad (40a)$$

[00107] By expanding the sum for the case of $N=3$, the optimum decision rule for multiple symbol non coherent detection rule becomes:

$$(d_k, d_{k-1}) = \arg \max_{d_k, d_{k-1}} \left| (r_{2,k-2} - r_{1,k-1}) d_{k-1} + (r_{2,k-1} - r_{1,k}) + (r_{2,k} - r_{1,k+1}) d_k \right| \quad (41)$$

In step 15-70, equation (41) is realized and the maximization implemented over all possible data symbols $d_k \in \{+1, -1\}$. Note that this metric is independent of dc offset and can be used even without using (39).

[00108] Referring now to Fig. 16, the Trellis diagrams from the encoder structure of Fig. 14 is shown in trellis 16-2 for FM0 and in trellis 16-4 for Miller code. These Trellis diagrams are used for the SISO decoder for application of passive RFID tag standards which employ these encoding techniques. In the presence of random phase and timing, the Trellis diagram may be too large and impractical to be illustrated graphically. That is due to the large number of states and transitions (e.g. 2000 states and 20 transitions per state) which depends on the choice of the cardinality of the sets in equations (10) and (12).

[00109] Referring now to Fig. 17, the performance of detectors in Fig. 15a, 15b and 15c are compared. The theoretical performance of coherent and non-coherent detector over AWGN are also depicted with solid lines and the performance of multiple symbol non-coherent MSNC is simulated and shown by small triangles. It is noted that the performance of the symbol non-coherent detector outperforms the classical non-coherent detector by a factor of 3.5 dB.

[00110] In SISO decoder 4-2 a long sequence, typically a packet or a frame, is processed at a time. Hence, the performance is still even superior to that of symbol non-coherent detection in which the Maximum Likelihood detector is considering only three symbols. In applications for system 13-10 are for RFID tag standards in which the tag protocol is amenable to longer latency which results from the SISO decoding. Typical applications of multiple symbol non-coherent detector 15-70 are when the RFID standard requires very strict timing requirements between the tag-to-reader and reader-to-tag packet inter-arrival time. These tight timings requirements typically occur when acknowledgement or replies are required from the reader to the RFID tag or vice versa. In certain circumstances and for certain RFID tag standards, it is also possible to employ both systems 13-10 and 15-70 so that for certain packets types which the system 15-70 is used and system 13-10 may be used for other timing critical packets. Specifically, when detecting the product code itself from the received packet, SISO decoding in 13-10 may be used, but for other packet types which are short replies and handshake, system 15-70 may be used.

[00111] Referring now to Figs 18 and 19, a typical problem for many digital communication systems is that the baud rate is fixed, i.e. the transmitted pulse duration is fixed. In sensor networks and RFID systems in particular, the transmitted pulses from the tag can change in duration from symbol to symbol. Thus at the reader's receiver, the duration of pulses or the instantaneous time varying baud rate should be tracked. In order to track timing for such applications, a timing trellis may be used.

[00112] Assume that the time axis is sampled at time instants iT_s , where $1/T_s$ represent the sampling rate. The sampling points at the output of matched filter are depicted by bullets "•" on the time axis in Fig. 19-10. There may be N samples per nominal baud interval. Thus the nominal symbol duration would be $T_s = NT_s$, where T is the nominal symbol duration. Assume the symbol duration from symbol to symbol can increase (as a result for example of changing channel characteristics) by one sample to $T_s = (N+1)T_s$ with probability p , or no change $T_s = NT_s$ with probability $(1-2p)$, or can decrease by one sample to $T_s = (N-1)T_s$ with probability p .

[00113] Each interval has N tick marks that denote possible positions (in multiples of T_s), where a sample can be taken at the output of the matched filter. From Fig. 19, some intervals have one tick mark as depicted in 19-2, 19-3 and 19-4, some intervals have two tick marks, while some intervals have no tick marks as shown in 19-12. Denote the timing state as S_k which its value corresponds to a tick mark. The state is associated with a time interval $((k-1)T, kT]$, and can take one of the values in the following set: $S_k = s_0, s_1, \dots, s_N, s_{N+1}$. State s_0 denotes that the k th symbol interval $((k-1)T, kT]$ is not sampled at all. For example, in Fig. 19, the interval corresponding to $S_k = s_2$ shown in 19-13 is sampled at the second tick from the start of the interval. State $S_k = s_i$, for $1 \leq i \leq N$ denotes that the k th symbol interval $((k-1)T, kT]$ is sampled only once at the i -th tick.

[00114] Referring now also to Fig. 18, state $S_k = s_{N+1}$ (for $N=8$ in Fig. 19) denotes that the k th symbol interval $((k-1)T, kT]$ is sampled twice. The only way an interval can be sampled twice is if it is sampled at the first and N th ticks, since we only allowed maximum of one sample variation from symbol to symbol. The constraints prevent any other way of two samples falling in the same interval. There are some restrictions on how the sampling-states S_k can evolve. To represent all valid sampling-state transitions, we form a timing trellis, depicted in Fig. 18. To a branch in the timing trellis, we associate a transition probability $\Pr(S_k | S_{k-1})$. The transition probabilities can be computed based on parameter p . A key feature of the

timing trellis in Fig. 18 is that the branches in the trellis carry a variable number of samples. We will denote the vector of samples taken in the timing interval $((k - 1)T, kT]$ by r_k . Note that r_k could be an empty vector if no sample is taken in the k th symbol interval.

[00115] The timing trellis has $N + 2$ states. The present state S_{k-1} i.e. S_0 through S_9 (18-12) and next states S_k i.e. states S_0 (18-14) through (18-16) are shown in Fig. 18. Lets assume $N=8$ for clarification and rectangular NRZ pulses. For symbols with nominal duration of 8 samples, the matched filter sums the recent 8 samples. To transition from state S_0 to state 1, the matched filter sums nine recent samples and produces observation r_k . To transition from state S_0 to state 9, the matched filter sums nine recent samples and produces observation r_k , and the next seven samples to produce observation r_{k+1} corresponding to data a_k and a_{k+1} respectively. Each state also should store the most recent index of observation sample. The branch metric per edge of trellis requires variable number of samples. Denote the index of observation sample to state S_{k-1} at time $k-1$ by q_i , then the number of samples required to compute the edge branch metric are $q_i + N(s_i, s_j)$ samples. Where $N(s_i, s_j)$ represent the number of samples required to compute the branch metric from present state $S_{k-1} = s_i$ to next state $S_k = s_j$. For $N=8$:

$$\begin{aligned}
 &N(s_0, s_1)=9 \quad N(s_0, s_9)=9+7 \quad N(s_1, s_1)=8 \quad N(s_1, s_2)=9 \quad N(s_1, s_9)=8+7 \\
 &N(s_2, s_1)=7 \quad N(s_2, s_2)=8 \quad N(s_2, s_3)=9 \quad N(s_2, s_9)=7+7 \quad N(s_{2+i}, s_{2+i-1})=7 \text{ for} \\
 &i=1,2,3,4,5 \\
 &N(s_{2+i}, s_{2+i})=8 \text{ for } i=1,2,3,4,5 \quad N(s_{2+i}, s_{2+i+1})=9 \text{ for } i=1,2,3,4,5 \quad N(s_8, s_0)=\text{no samples} \\
 &N(s_8, s_7)=7 \quad N(s_8, s_8)=8 \quad N(s_9, s_0)=\text{no samples} \quad N(s_9, s_7)=7 \quad N(s_9, s_8)=8
 \end{aligned}$$

[00116] Referring now to Fig. 20, a folded timing trellis is similar to the method shown in Fig.s 18 and 19, except the number states are less and number of transitions per state is fixed number for all timing states. The time axis may be sampled at time instants iT_s , where $1/T_s$ represent the sampling rate. The sampling points at the output of matched filter (end of actual symbol time duration) are depicted by bullets “•” on the time axis in Fig. 19-10. Assume there are N samples per nominal baud interval. Thus the nominal symbol duration is $T_s = NT_s$, where T is the nominal symbol duration. Assume the symbol duration from symbol to symbol can

increase by one sample to $T=(N+1)T_s$ with probability p , or no change $T=NT_s$ with probability $(1-2p)$, or can decrease by one sample to $T=(N-1)T_s$ with probability p .

[00117] Each interval has N tick marks that denote possible positions (in multiples of T_s), where a sample can be taken at the output of the matched filter. The state is associated with a time interval $((k - 1)T, kT]$, and can take one of the values in the following set: $S_k = s_1, \dots, s_N$. State $S_k = s_i$, for $1 \leq i \leq N$ denotes that the k th symbol interval $((k - 1)T, kT]$ is sampled at the i -th tick from the beginning of the interval. There are some restrictions on how the sampling-states S_k can evolve. To represent all valid sampling-state transitions, a timing trellis may be formed as depicted in Fig. 20. To a branch in the timing trellis, a probability $\Pr(S_k | S_{k-1})$ can be assigned to a transition. The transition probabilities can be computed based on parameter p . A key feature of the timing trellis in Fig. 20 is that the branches in the trellis carry a variable number of samples. The vector of samples taken in the timing interval $((k - 1)T, kT]$ can be denoted by r_k .

[00118] The timing trellis has N states. Lets assume $N=8$ for clarification. The present states S_{k-1} i.e. S_1 (20-10) through S_8 (20-12) and next states S_k i.e. states S_1 (20-14) through (20-16) are shown in Fig. 20. Also assume rectangular pulses. For symbols with nominal duration of 8 samples, the matched filter sums the recent 8 samples if there is a transition from present state S_i to the next state S_i for $i=1,2,\dots,N$ (for the example in Fig. 20, $N=8$). For symbols with nominal duration of 8 samples, the matched filter sums the recent 9 samples if there is a transition from present state S_i to the next state S_{i+1} for $i=2,3,\dots,N$, and S_1 to S_8 (for the example in Fig. 20, $N=8$). For symbols with nominal duration of 8 samples, the matched filter sums the recent 7 samples if there is a transition from present state S_i to the next state S_{i-1} for $i=1,2,\dots,N-1$, and from present state S_N to S_1 (for the example in Fig. 20, $N=8$). Each state also should store the most recent index of observation sample to compute the branch metric for the next trellis section. Thus the branch metric per edge of trellis requires variable number of samples. Denote the index of observation sample to state S_{k-1} at time $k-1$ by q_i , then the number of samples required to compute the edge branch metric are $q_i+N(s_i,s_j)$ samples. Where $N(s_i,s_j)$ represent the number of samples required to compute the branch metric from present state $S_{k-1}= s_i$ to next state $S_k= s_j$. For $N=8$:

$$N(s_1,s_2)=7 \quad N(s_1,s_1)=8 \quad N(s_1,s_8)=9$$

$$\begin{aligned}
N(s_i, s_{i-1}) &= 7 \quad \text{for } i=1,2,3,4,5,6,7 \\
N(s_i, s_i) &= 8 \quad \text{for } i=1,2,3,4,5,6,7,8 \\
N(s_i, s_{i+1}) &= 9 \quad \text{for } i=2,3,4,5,6,7,8 \\
N(s_8, s_1) &= 7 \quad N(s_8, s_8) = 8 \quad N(s_8, s_7) = 9
\end{aligned}$$

[00119] Referring now to Figs 21 and 22, the symbol timing tree structure is based on a nominal value of N samples per symbol. This means that the granularity of the timing captured will be $\frac{1}{N \times F_s}$ where F_s is the sampling frequency. The rates may be discussed in the $\frac{1}{F_s}$ domain, meaning that rates will be expressed in percentage of the sample rate, and time in samples. To build a structure that can be integrated into the trellis form, an estimate of the first symbol time must be provided that is accurate to one symbol period ($\pm \frac{N}{2}$). If the first symbol time cannot be estimated to this accuracy, a separate synchronization sequence may be required. States are labeled $S_{M,t}$ for the i th state in the M th stage. In the general case, there may be N starting states, labeled from $S_{0,0}$ to $S_{0,N-1}$. Each state $S_{M,t}$ has $2 \times \Delta_{max} + 1$ (where Δ_{max} represents the maximum number of samples from symbol duration can exceed from nominal symbol duration) transitions leading to consecutive states starting at $S_{M+1, t - \Delta_{max}}$ and ending at $S_{M+1, t + \Delta_{max}}$. To further refine the structure, an a-priori estimate of the maximum timing error (expressed in samples per symbol) of R can be used. If N is nominal number of samples per symbol, then $R = rN$ where r is percentage of timing error. The definition of R becomes $\Delta_{max} = \lceil R \rceil$ which is an integer. This limits the states at any given trellis stage M to states starting at $S_{M, 0 - \lfloor R \times M \rfloor}$ up to $S_{M, N-1 + \lceil R \times M \rceil}$ where $\lceil x \rceil$ is the ceiling of x (the next higher integer), and $\lfloor x \rfloor$ is the floor of x (the next lower integer). This means that at any stage M the state $S_{M,t}$ corresponds to a symbol that starts at sample time $M \times N + t$. An example of this structure for $\Delta_{max} = 1$ and $N = 4$ is shown in Fig. 22.

[00120] Referring now to Fig. 23, a second, derived structure involves using the same tree, but windowing it to limit the number of states is shown as the windowed structure in Fig. 23. For the windowed structure, an additional parameter W may be defined as the size of the window into the tree. In this way, only W states at any trellis stage M are kept where the first state index is defined as B_M (the base state). In order to find B_M at time $M+1$ the window

position may be chosen based on the probability of the states $S_{M, BM}$ through $S_{M, BM + \Delta_{max} - 1}$ compared to $S_{M, BM + W - 1}$ down to $S_{M, BM + W - \Delta_{max}}$.

[00121] The result may be called a ‘folded’ structure (also simply the ‘trellis’ structure). In this structure there are precisely N states at each stage M . In order to accomplish this, the tree structure may be folded such that state $S_{M, t}$ is mapped into state $Z_{M, t \% N}$, where $\%$ denotes the modulo operator into positive integers (i.e. $(-1) \% N = N - 1$). In order to maintain timing in this structure, each state $Z_{M, t}$ has a mapping value t_m that the index of the maximum probability state $S_{M, k}$ that maps into $Z_{M, t}$. At each stage, t_m , to transitions from the state are determined.

[00122] In all of these timing structures, this trellis may be combined with the data trellis and phase trellis to get a combined set of states $S_{M, t, \phi, D}$. Each transition out of this state has a triplet of values $(\Delta_t, \Delta_\phi, b)$ where Δ_t is the timing change and it takes integer values between $-\Delta_{max}$ and Δ_{max} , i.e. $-\Delta_{max}, \Delta_{max} + 1, \dots, -1, 0, 1, \dots, \Delta_{max} - 1, \Delta_{max}$, Δ_ϕ is the phase change, and b is the data bit. In the case of any binary waveforms (e.g. FM0 and Miller), the data metric

for this state and transition is $\text{Re} \left\{ e^{-j(\phi + \Delta_\phi)} \sum_{i=0}^{N-1+\Delta_t} c_{D, b, i} \times r(M \times N + t) \right\}$ where

$c_{D, b, i} = d_{D, b, k} \times (1 - \text{off}) + d_{D, b, k+1} \times \text{off}$ and $d_{D, b, k}$ is an ideal symbol at the nominal sample rate, where $k = \lfloor i \times \frac{N + \Delta_t}{N} \rfloor$ and $\text{off} = \left(i \times \frac{N + \Delta_t}{N} \right) - k$. Note that for the ‘folded’ version, t_m is used in place of t .

[00123] In order to capture the timing information with symbol timing that can drift over time, another natural structure of the timing state diagram is a tree structure such as shown in 21-2 where the root node is extended. Assume the nominal timing is N samples per symbol. This means that the granularity of the timing captured from the tree structure will be $\frac{1}{N}$. In order to improve the performance of the trellis, this can be limited to an arbitrary rate R . To do this, the states that would fall outside the bounds of the expected drift are eliminated. If the states are numbered for the first stage of the trellis as S_0 to S_{N-1} for the first stage, the second stage would be numbered $S_{0 - \Delta_{max}}$ to $S_{N + \Delta_{max}}$, and for stage M they would be $S_{0 - M \times \Delta_{max}}$ to $S_{N + M \times \Delta_{max}}$. For this M th stage the states $S_{0 - M \times \Delta_{max}}$ up to but not including $S_{0 - \lceil R \times M \rceil}$

would be elided and also states above $S_{N-1+\lceil R \times M \rceil}$. Each state in this structure has a T_s associated with it that is $M \times N + i$ for state S_i at time M .

[00124] In order to reduce the complexity of the structure, either a ‘folded’ tree or a ‘windowed’ tree can be used. The ‘folded’ tree is a tree where node S_i is mapped to $S_{(i+N) \% N}$ and the T_s associated with the node is the T_s associated with the maximum state value between the mapped states. This means that the transitions become symmetric as in a true trellis, but the transitions carry both a metric and a time with them. In a ‘windowed’ tree structure, an arbitrarily sized window of states is maintained. This window is selected by comparing the probabilities of the edge states. In the case of a windowed tree, one only needs to keep track of T_s for the first state in the window (all other states will be offset linearly from that state). This provides an advantage of smaller storage and simpler implementation.

[00125] Combined Metrics for Data and Timing

$$\sum_{i=1}^{N+\Delta t} d_{in}(i) \times r(T_s + i)$$

Where

- $r(i)$ is the sample at time i
- $d(i)$ is the ideal symbol sampled at the sample rate (for the data state and input data from the trellis)
- $d_{in}(i)$ is the interpolated version of ideal symbol.
- T_s is the time stored in the state.

$$p = \lfloor i \times \frac{N + \Delta t}{N} \rfloor$$

- $off = \left(i \times \frac{N + \Delta t}{N} \right) - p$

$$d_{in}(i) = d(p) \times (1 - off) + d(p + 1) \times off$$

An example for is given for the case of $N=4$, $R=10\%$, $M=4$ in 22-2 and 22-4.

[00126] Referring now to Fig. 24, a SISO decoder can be viewed as consisting of four consecutive operations:

- 1) data metric generation and phase rotation
- 2) Branch metric generation and forward node update
- 3) Backward pass node update

4) Extrinsic generation and output

[00127] Basically, the decoder structure can be viewed as a trellis of nodes arranged in columns. Each column corresponds to one symbol of the data stream to be decoded. The nodes within the columns represent the possible combinations of the relevant parameters for the symbol; in particular, the timing, phase, and symbol states. Each contains a numerical value proportional to the computed probability of the parameters which it represents. For FM0, one can use 512 nodes per column corresponding to the combinations of the 16 possible (quantized) phase states, the 16 possible timing states, and the two possible symbol values (0 and 1). The decoder operates by estimating the probability of each node's combination of parameters using metrics derived from the input data. First, probabilities for the nodes within columns are updated in the forward time direction, and then in reverse working backwards through the trellis. When these updates have been completed, the highest computed probability values through the trellis are chosen for the decoded output.

[00128] The inputs to the SISO decoder trellis computation are the data metrics which are derived from the sampled input stream. These are complex numbers, derived from S_i sample values containing both I and Q components. Although there are a total of twelve data metrics which must be computed for each discrete sample time, N , six of these are simply negatives of the others as selected by D , the current data symbol state. The metrics, $M_N(\Delta t, D, d)$, where $\Delta t = \{-1, 0, +1\}$ for timing change, $D = \{0, 1\}$ for current data state, and $d = \{0, 1\}$ for the next symbol value, may be computed from intermediate variables A , B , C , D , E , and F where:

$$\begin{aligned}
 A &= \sum S_i, (n \leq i \leq n+7) && = \text{sum of 8 samples starting at time } n \\
 B &= \sum S_i, (n+8 \leq i \leq n+15) && = \text{sum of 8 samples starting at time } n + 8 \\
 C &= \sum S_i, (n \leq i \leq n+6) && = \text{sum of 7 samples starting at time } n \\
 D &= \sum S_i, (n+8 \leq i \leq n+14) && = \text{sum of 7 samples starting at time } n + 8 \\
 E &= \sum S_i, (n \leq i \leq n+8) && = \text{sum of 9 samples starting at time } n \\
 F &= \sum S_i, (n+9 \leq i \leq n+16) && = \text{sum of 8 samples starting at time } n + 9
 \end{aligned}$$

[00129] Referring now specifically to Fig. 24, the Intermediate Metric Variable Computation is shown. The FM0 data metrics $M_N(\Delta t, D, d)$, can then be derived from the intermediate variables as follows:

$$\begin{aligned}
 M_N(0,0,0) &= A_N - B_N && = && - M_N(0,1,0) \\
 M_N(1,0,0) &= A_N - F_N && = && - M_N(1,1,0) \\
 M_N(-1,0,0) &= C_N - D_N && = && - M_N(-1,1,0) \\
 M_N(0,0,1) &= A_N + B_N && = && - M_N(0,1,1)
 \end{aligned}$$

$$\begin{aligned} M_N(1,0,1) &= E_N + F_N &= &- M_N(1,1,1) \\ M_N(-1,0,1) &= A_N + D_N &= &- M_N(-1,1,1) \end{aligned}$$

[00130] Regarding phase rotation, the node update operation does not use the M_N directly, but rather uses the real portion of the complex data metric vector as rotated by the interpolated phase, ϕ , for each trellis branch. The rotated data metric is expressed as $R_N(\phi) = \text{Re}[M_N * e^{j\phi}]$. Since there are only sixteen evenly spaced discrete values for the node phase state, the interpolated branch phase can only take on 32 values and the product computation is greatly simplified. This is shown in the table below. Due to symmetry, 16 of the values are simply derived by negation of those calculated π radians away. This means that all 32 rotations can be computed using 14 multipliers and 14 adder/subtractors. By sequencing the 6 values for M_N as input into the phase rotator block, all 32 rotations of all twelve metrics may be computed in real-time at the sample rate. The outputs are fed to the node processors for branch metric computation where they are added or subtracted as needed.

[00131] Regarding backwards pass data metric storage and sequencing, the rotated data metrics must also be fed to the node update mechanism for the backwards node update pass. This requires either storage of the values computed for the forward pass, or else regeneration from either the data or data metrics. In either case storage memory is necessary. Using a 256-bit packet for purposes of illustration, storage of the rotated data metrics would require: $16 \times 6 \times 16 \times 256 = 393,216$ (16-bit) words of storage. At the other extreme, storage of the interpolated input data stream would require only $2 \times 16 \times 256 = 8192$ words of storage. While storing the interpolated data alone would save substantial memory, it requires that the metric generation shift-register (as shown above) be run in the reverse direction (from right-to-left), with the stored data fed to it reversed in time, in order to derive the data metrics for the backwards pass. The data resurrected data metric values must be fed to the phase rotator as before. The $R_N(\phi)$ outputs must, however, be resequenced for presentation to the node processors. Recall that for the data metrics, $M_N(\Delta t, D, d) = -M_N(\Delta t, \sim D, d)$. This allowed the nodes with $D=1$ during the forward update pass simply to be fed the negatives of the $R_N(\phi)$'s for their $D=0$ counterparts. During the backwards pass, however, we are indexing the node processors by d instead of D since our source nodes are now later in time. Consequently, the $M_N(\Delta t, D, d)$ are no longer the arithmetic complements for $d=0$ vs. $d=1$; and instead the proper $R_N(\phi)$ must be stored, sequenced, and fed to the node processors.

[00132] Regarding branch metric generation and node updating, the branch metrics, B_{XY} , where X is the originating node within symbol column C, and Y the destination node in column C+1, are calculated as

$$B_{XY} = d * S_C + R_N(\varphi, \Delta t, D, d) + U(\Delta \varphi) + V(\Delta t)$$

Where d = the destination data state (i.e. input data bit value)

S_C = Soft input value for column C

$R_N(\varphi, \Delta t, D, d) = \text{Re}[M_N(\Delta t, D, d) * e^{j\varphi}]$, the rotated data metric

$U(\Delta \varphi) =$ one value for $\Delta \varphi = 0$, another for $\Delta \varphi = +1, -1$

$V(\Delta t) =$ one value for $\Delta t = 0$, another for $\Delta t = +1, -1$

[00133] For FM0, there are 18 branches out of each source node, corresponding to the 3 values for $\Delta \varphi$, times the 3 values for Δt , times 2 values for d . Accordingly there are also 18 branches into each destination node. To update the probability score, Q_Y , for a destination node, the Q_X from the source node is added to the branch metric for all input branches leading directly to node Y. The value for the branch with the greatest sum is then selected and stored for Q_Y . The associated sample time value, T_Y , must also be stored, where $T_Y = T_X + 16 + \Delta t$ (or for reverse updates: $T_Y = T_X - 16 - \Delta t$), and T_X is the stored time value from the source node for the selected branch.

Table for Phase Rotation

Data Metric $M_N = x + jy$

$$\begin{aligned}
 a &= \cos(\pi/8), & b &= \sin(\pi/8) \\
 c &= \sin(\pi/4) = & \cos(\pi/4) \\
 d &= \cos(\pi/16), & e &= \sin(\pi/16) \\
 f &= \cos(3\pi/16), & g &= \sin(3\pi/16)
 \end{aligned}$$

Angle ϕ	$e^{j\phi}$ Real Part	$e^{j\phi}$ Imaginary Part	Real Part of Metric Product
0	1	0	x
$\pi/16$	d	e	dx - by
$\pi/8$	a	b	ax - by
$3\pi/16$	f	g	fx - gy
$\pi/4$	c	c	cx - cy
$5\pi/16$	g	f	gx - fy
$3\pi/8$	b	a	bx - ay
$7\pi/16$	e	d	ex - dy
$\pi/2$	0	1	-y
$9\pi/16$	-e	d	-ex - dy
$5\pi/8$	-b	a	-bx - ay
$11\pi/16$	-g	f	-gx - fy
$3\pi/4$	-c	c	-cx - cy
$13\pi/16$	-f	g	-fx - gy
$7\pi/8$	-a	b	-ax - by
$15\pi/16$	-d	e	-dx - gy
π	-1	0	-x
$17\pi/16$	-d	-e	-dx + ey
$9\pi/8$	-a	-b	-ax + by
$19\pi/16$	-f	-g	-fx + gy
$5\pi/4$	-c	-c	-cx + cy
$21\pi/16$	-g	-f	-gx + fy
$11\pi/8$	-b	-a	-bx + ay
$23\pi/16$	-e	-d	-ex + dy
$3\pi/2$	0	-1	y
$25\pi/16$	e	-d	ex + dy
$13\pi/8$	b	-a	bx + ay
$27\pi/16$	g	-f	gx + fy
$7\pi/4$	c	-c	cx + cy
$29\pi/16$	f	-g	fx + gy
$15\pi/8$	a	-b	ax + by
$31\pi/16$	d	-e	dx + ey

[00134] Regarding the data-driven update mechanism, the 16 values output from phase rotation for the rotated data metrics, $R_N = \text{Re}[M_N * e^{j\varphi}]$ for $D = 0$; $\varphi = 0, \pi/8, \pi/4, 3\pi/8, 3\pi/2, 13\pi/8, 7\pi/4$, and $15\pi/8$, and specified N , d , and Δt ; are fed to the node update mechanism. Since the remaining phase angles can also be derived from these 16 simply by negating the corresponding value π radians away; and since the values of the R_N for $D=1$ are also just the negatives of those for $D=0$; each set of the eight R_N values is sufficient for metric generation for the three branches ($\Delta\varphi = -1, 0, +1$) from up to 32 source nodes (all nodes of the specified time state N) in the originating symbol column, C . These R_N values may be labeled as negated for specified values of φ and D as $R_{N\varphi D}$. For forward update, the $R_{N\varphi D}$ are fed into 32 node processors. These processors compute the branch metrics B_{XY} and sum them with the stored source node values, Q_X . The branch sums are passed to 16 branch selection units which compare six input branch values and select the largest for output. Each selection unit corresponds to a specific phase value, φ_Y . The inputs are then the branches where $\varphi_Y = \varphi_X - (\Delta\varphi * \pi/8)$, including the branches for both $d=0$ and $d=1$. The outputs of these selection units then feed back to the two node processors of corresponding phase where they are used to update the stored Q_Y value for the destination node. A minimum of ninety-six clocks are required to update each symbol column. For the reverse update direction, the rotated metrics are regenerated starting with the most recent symbol, and proceeding back to the first. The later column nodes (to the right in the trellis) are used for the source values, Q_X , and the earlier column to the left are now updated as the Q_Y .

[00135] Referring now to Fig. 25, the interconnection of node processors and branch select units are shown. For convenience, upwards arrows to $\Delta\varphi = +1$ for forward updates, -1 for backwards updates. Downwards arrows are for branches with $\Delta\varphi = -1/+1$ for forward/backward updates. Horizontal arrows are for $\Delta\varphi = 0$.

[00136] Referring now to a source node processor, the proposed implementation consists of 32 node processors, each assigned to a particular data state value (0 or 1), and phase state (0 to 15). One of the eight R_N values, or its arithmetic complement, as appropriate, are fed into each node processor corresponding to its assigned data and phase state values. Each processor consists of a node memory, a comparator, and four adders. This structure is shown in the diagram below. The node memory stores two values for each node, the probability score Q ,

and the time code T . Each processor's node memory contains all trellis nodes for a specific data state, D , and for a specific phase state value, ϕ . It also contains the storage for the nodes in all trellis symbol columns, C , and for all sixteen time state values, N . For a 256 symbol decoder, $16 \times 256 = 4096$ node storage locations would be required. Local storage can be greatly reduced for large message sizes if paging to external memory is implemented.

[00137] The adders function to generate three branch metrics on each clock as the six R_N 's are fed in sequentially for each N . Therefore, a minimum of 96 clock cycles are required to update a symbol column. The adders serve to sum the various terms for the branch metric values B_{XY} with the source node value, Q_X . The value $d \cdot S_C$, being global to all processors, is developed externally. The value for $V(\Delta t)$ is also selected outside and summed with $d \cdot S_C$ to be fed to the node processors as an input. Remaining inputs are the symbol column number C , which is concatenated with the timing sample state N to address a particular node within local storage; the rotated metric value $R_{N\phi D}$, and the two values for $U(\Delta\phi)$.

[00138] Referring now to destination node processing, as the $R_{N\phi D}(d, \Delta t)$ are fed into the source node processors, sequentially stepping through the six combinations of d and Δt for each sample time N , the $B_{XY} + Q_X$ sums are output to the destination nodes for comparison and selection. Since d is fixed at each clock, there are only sixteen destination nodes for the 96 branches generated on each clock. This means there are six potential branches into each destination node at each clock which need to be compared and selected for the maximum. Along with the branch sum, the corresponding time value, T_X from the source node for the winning branch must also be selected and stored. Destination processing can be performed by a seven-input maximum selector. The seventh input is used to compare any previous maximum partial results from the three update cycles required to examine all eighteen of the branches into a destination node. The results of each of these sixteen selectors is shared as input to the two node memories sharing the same time state value, N , but one with $D=0$, and one with $D=1$. It should be noted that the destination node N_Y time-state value is not necessarily the same as the source N_X value, but is rather equal to $(N_X + \Delta t)$ modulo 16.

[00139] Referring now to time divergence, a possible problem with the basic source node processing as shown in the diagram above lies in the way in which the trellis tracks timing. There are several timing variables of interest. T refers to absolute sample time as numbered sequentially from the first data sample. Each node in the trellis also has a fixed 4-bit timing

state value, N , ranging from 0 to 15. This 4-bit value always corresponds to the LS 4-bits of the absolute sample time assigned to that particular node. That assigned T can, however, change within the symbol column depending upon T_{XY} value for the branch selected during node update, where $T_{XY} = T_X + \Delta t$. This T_{XY} value should therefore be stored in the node when it is updated. When generating the branch metric values, it may be necessary to compare the stored T_X for the node with the sample time $T_{N\phi D}$, as it is possible for the stored T assigned to a node with timing state N , to be different. This means that with the basic architecture of the diagram, multiple passes may be needed to present the rotated data metric for all node T values at a given N , ϕ , and D in order to generate all of the branch metrics. This is the reason for the equality comparator and the valid line shown in the diagram. In order to increase parallelism and reduce the number of clock passes required, it is highly desirable to present several possible rotated metrics in parallel to the node processor so that branches for varying T 's, but with specified N , can be generated simultaneously. Source node processing architecture for multiple parallel T updates is shown below. Since total divergence is limited by the length of the data packet, and since the LS-4 bits are redundant, it is not necessary that all bits of T_{XY} be stored and compared in the node processor. The additional $R_{N\phi D}$ can be made available by saving the 8 rotated metric values generated for each clock in delay storage of length 96 clocks for each additional $R_{N\phi D}(T)$ to be presented. This requires four 18K block RAM for every two additional values of T , if the RAM is operated at the same clock rate as the branch metric generator.

[00140] Referring now to Fig. 26, the extended parallel source node processing is shown.

[00141] Referring now to Fig. 27, the forward and backward processing is shown.

ϕ	Data Stat e	Phase State	Forward $R_{Nd}(\phi)$	Backward $R_{Nd}(\phi)$
0	0	0	$R_{NX}(0)$	$R_{N0}(0)$
0	1	0	$-R_{NX}(0)$	$R_{N1}(0)$
$\pi/8$	0	1	$R_{NX}(\pi/8)$	$R_{N0}(\pi/8)$
$\pi/8$	1	1	$-R_{NX}(\pi/8)$	$R_{N1}(\pi/8)$
$\pi/4$	0	2	$R_{NX}(\pi/4)$	$R_{N0}(\pi/4)$
$\pi/4$	1	2	$-R_{NX}(\pi/4)$	$R_{N1}(\pi/4)$
$3\pi/8$	0	3	$R_{NX}(3\pi/8)$	$R_{N0}(3\pi/8)$
$3\pi/8$	1	3	$-R_{NX}(3\pi/8)$	$R_{N1}(3\pi/8)$

$\pi/2$	0	4	$-R_{NX}(3\pi/2)$	$-R_{N0}(3\pi/2)$
$\pi/2$	1	4	$R_{NX}(3\pi/2)$	$-R_{N1}(3\pi/2)$
$5\pi/8$	0	5	$-R_{NX}(13\pi/8)$	$-R_{N0}(13\pi/8)$
$5\pi/8$	1	5	$R_{NX}(13\pi/8)$	$-R_{N1}(13\pi/8)$
$3\pi/4$	0	6	$-R_{NX}(7\pi/4)$	$-R_{N0}(7\pi/4)$
$3\pi/4$	1	6	$R_{NX}(7\pi/4)$	$-R_{N1}(7\pi/4)$
$7\pi/8$	0	7	$-R_{NX}(15\pi/8)$	$-R_{N0}(15\pi/8)$
$7\pi/8$	1	7	$R_{NX}(15\pi/8)$	$-R_{N1}(15\pi/8)$
π	0	8	$-R_{NX}(0)$	$-R_{N0}(0)$
π	1	8	$R_{NX}(0)$	$-R_{N1}(0)$
$9\pi/8$	0	9	$-R_{NX}(\pi/8)$	$-R_{N0}(\pi/8)$
$9\pi/8$	1	9	$R_{NX}(\pi/8)$	$-R_{N1}(\pi/8)$
$5\pi/4$	0	10	$-R_{NX}(\pi/4)$	$-R_{N0}(\pi/4)$
$5\pi/4$	1	10	$R_{NX}(\pi/4)$	$-R_{N1}(\pi/4)$
$11\pi/8$	0	11	$-R_{NX}(3\pi/8)$	$-R_{N0}(3\pi/8)$
$11\pi/8$	1	11	$R_{NX}(3\pi/8)$	$-R_{N1}(3\pi/8)$
$3\pi/2$	0	12	$R_{NX}(3\pi/2)$	$R_{N0}(3\pi/2)$
$3\pi/2$	1	12	$-R_{NX}(3\pi/2)$	$R_{N1}(3\pi/2)$
$13\pi/8$	0	13	$R_{NX}(13\pi/8)$	$R_{N0}(13\pi/8)$
$13\pi/8$	1	13	$-R_{NX}(13\pi/8)$	$R_{N1}(13\pi/8)$
$7\pi/4$	0	14	$R_{NX}(7\pi/4)$	$R_{N0}(7\pi/4)$
$7\pi/4$	1	14	$-R_{NX}(7\pi/4)$	$R_{N1}(7\pi/4)$
$15\pi/8$	0	15	$R_{NX}(15\pi/8)$	$R_{N0}(15\pi/8)$
$15\pi/8$	1	15	$-R_{NX}(15\pi/8)$	$R_{N1}(15\pi/8)$

[00142] Extrinsic generation may be performed as the nodes are updated in the reverse direction. A reliability measure is also computed. The extrinsic is computed as $\text{Max}(\alpha_x + B_{xy} + \beta_y)$ over each column.

[00143] It is clear to a person having ordinary skill in this art that the techniques described above may be applied to a communication method or system for processing modulated signal with random data, and/or phase and/or unknown timing to estimate received data sequences or packetized data. The receiver may use iterative processing with soft-input-soft-output (SISO) components to combine channel decoding with equalization, demodulation, phase tracking, symbol timing, synchronization and interference cancellation as part or in whole. These techniques may be used for any wireless communication systems to model the observation space. These techniques may be used for sensory receiver system for detecting signals in presence of noise and channel distortion utilizing iterative method to detect the signal. A communication system may use these techniques for maximum likelihood sequence

estimation which may include lattice, trellis or tree structures or products thereof for joint estimation of phase, timing, data and/or baud rate. Such techniques may also be used in signal detection systems utilizing iterative methods for optimal detection of the signal in the presence of white noise and channel distortion such as those employing in-door wireless channels, out-door wireless channels, both line-of-sight or non-line of sight communications, wire line channel such as copper and fiber wires, underground or underwater sonar, recording channels such as hard disk storage and both volatile and non-volatile memory and/or combinations of any of these channels.

[00144] The disclosed techniques are useful in the detection of packetized data with unknown data pulse duration, random phase and unknown data, any combination or thereof. They are useful in digital packet radio systems employing soft-input-soft-output (SISO) decoding methods with or without cascaded iterative decoder and with or without channel encoding/decoding. These techniques may be used in communication systems employing channel coding methods including algebraic block codes, convolution and turbo codes, low density parity check, repeat-accumulate codes, and product codes cascaded with SISO decoders exchanging extrinsic information to optimally decode the user data. Similarly, these techniques may be used in communication systems employing channel coding including coding which can be represented via planar graph such as bipartite, tree or trellis diagram whereby the posteriori probabilities (extrinsic information) of each state can be computed and iteratively improved. Such communication systems may employing belief propagation method to decode the received sequence and exchange extrinsic information with the soft-input-soft-output decoder. A communication system or packet radio timing synchronization may be provided for any modulation scheme such as multi-level phase, position, amplitude in quadrature and in-phase (one or both). Further, such systems may be embedded in portable or stationary devices, in hubs, central office or network edge devices and may be implemented in software, such as a "Software Defined Radio", on special purpose or general purpose host computer and offered as a web service or general purpose signal processing platform.

Claims

1. A method for operating an RFID receiver, comprising:
 - sampling a received signal including RFID data signals from at least one interrogated RFID tag;
 - providing a set of predetermined probabilities of a received signal sample making a specific transition between data states, each predetermined probability related to data, timing and baud rate variables affecting the received signal;
 - applying the set of predetermined probabilities to each of a plurality of pairs of signal samples to determine probabilities of the received signal having made the specific transitions between each of the signal samples in that pair; and
 - processing the determined probabilities to recover RFID data signals by determining a sequence of transitions in the received signal having the highest probability of occurrence.
2. The method of claim 1 wherein each of the predetermined probabilities is also related to a phase variable affecting the received signal.
3. The method of claim 2 wherein the applying the set of predetermined probabilities, and the processing the determined probabilities, are iterated to recover the RFID data signals.
4. The method of claim 3 wherein the set of predetermined probabilities are related to transitions in a first direction, the method further comprising:
 - providing a second set of predetermined probabilities related to transitions in an opposite direction; and
 - applying the second set of predetermined probabilities to each of the plurality of pairs of signal samples to determine second probabilities of the received signal making the specific transitions between each of the signal samples in that pair in the opposite direction; and
 - processing the first and second determined probabilities to recover the RFID signals.

5. The method of claim 4 wherein applying the first and second set of predetermined probabilities, and the processing the first and second determined probabilities, are iterated to recover the RFID data signals.

6. The method of claim 5 wherein the applying and processing are iterated until further iterations do not further change the determined probabilities.

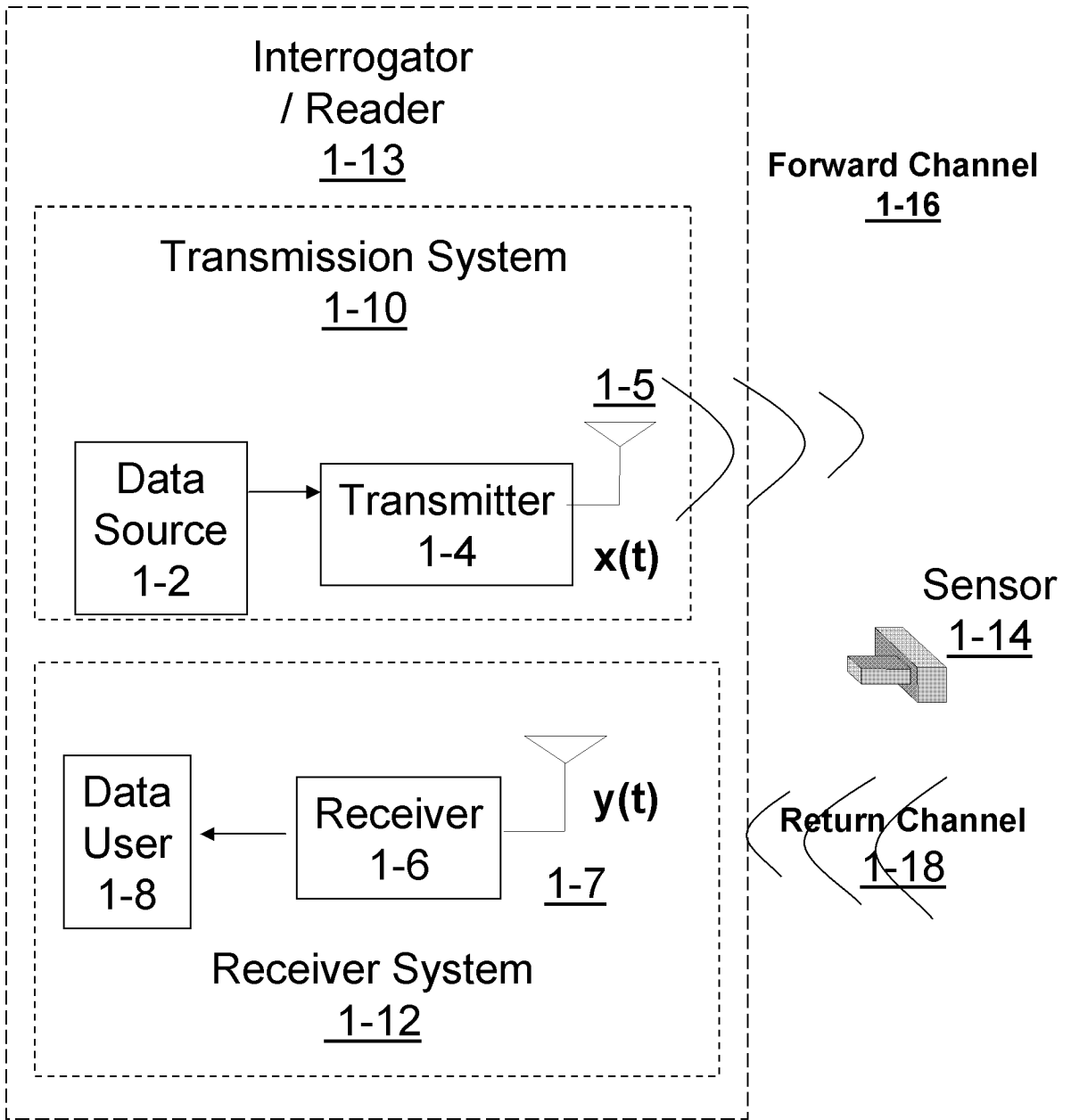

Fig. 1

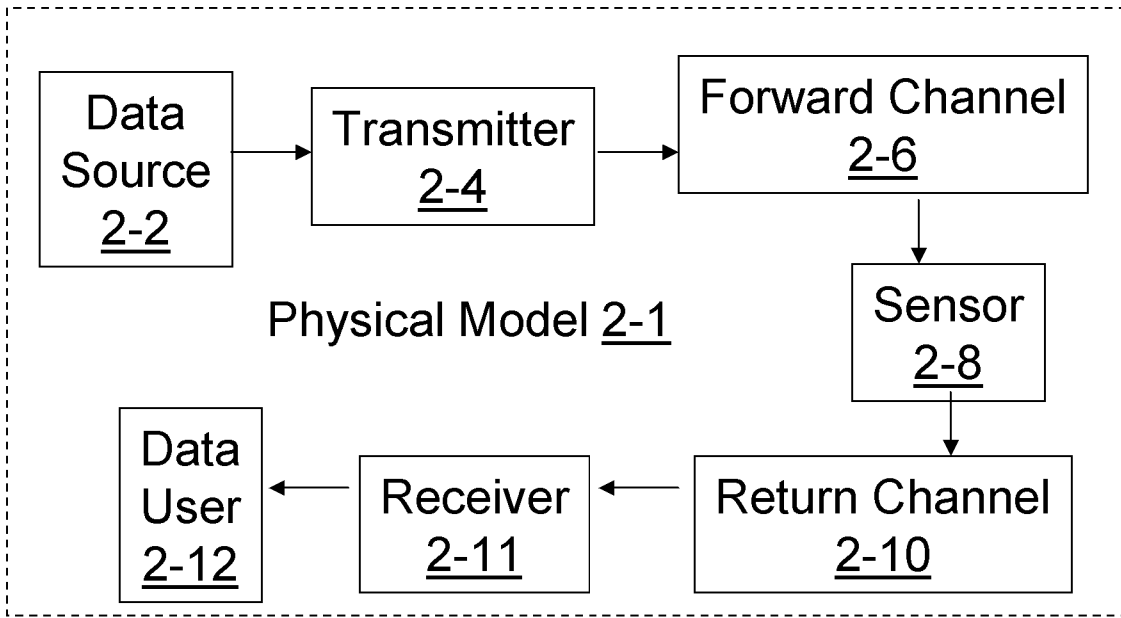

Fig. 2a

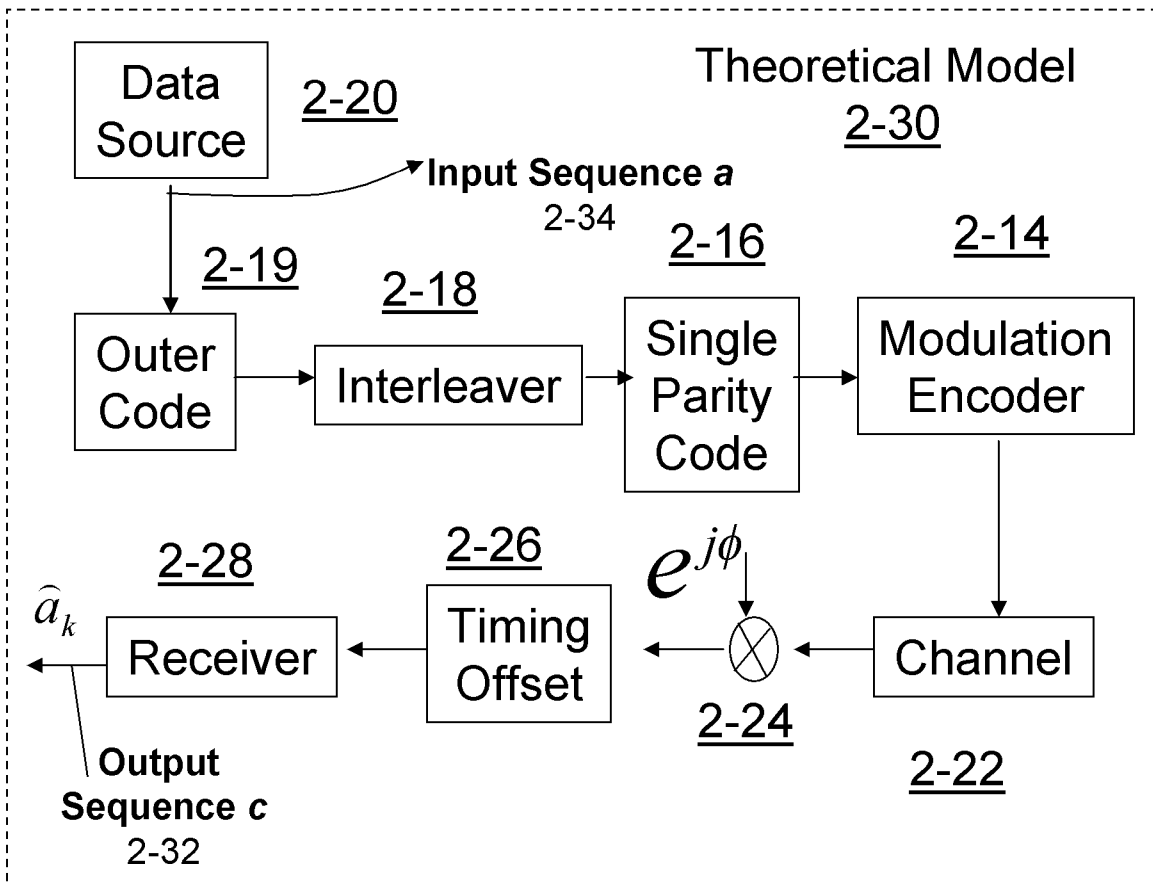

Fig. 2b

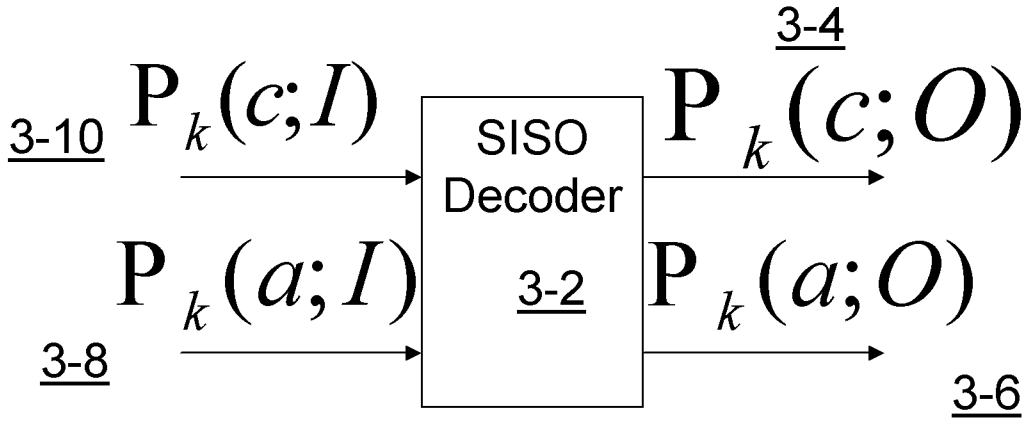

Figure 3.

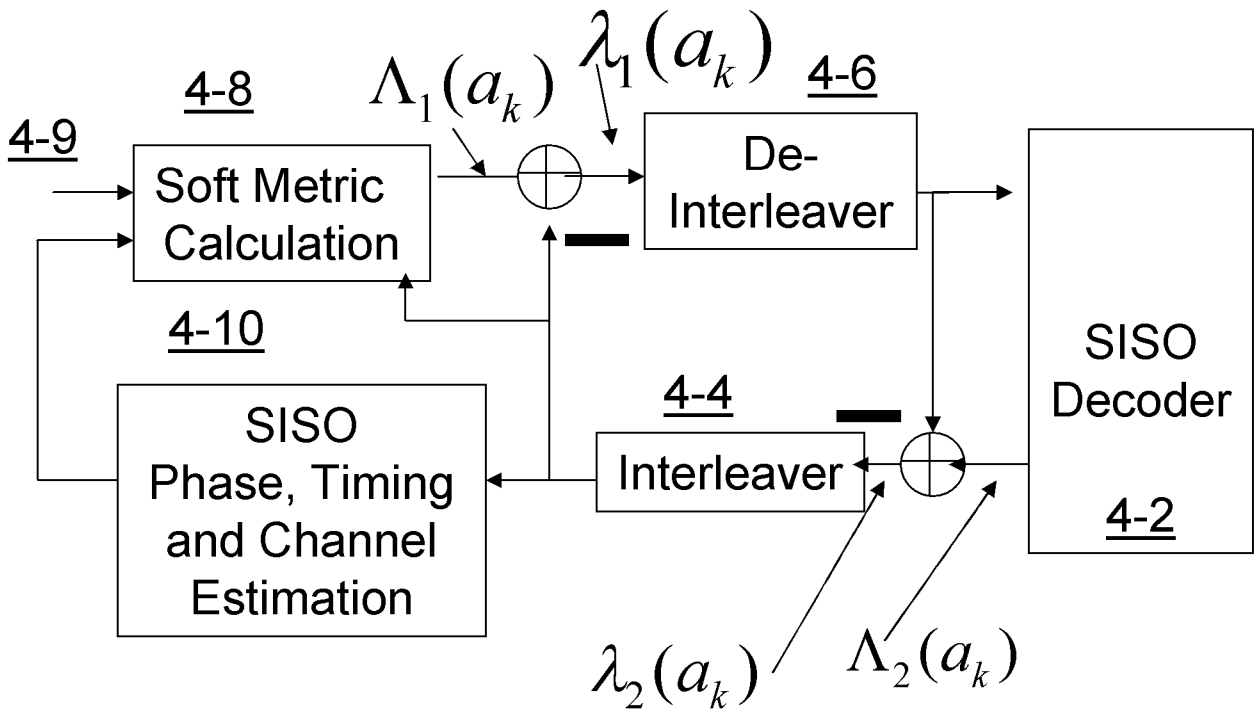

Fig.4

Quantized Phase Space

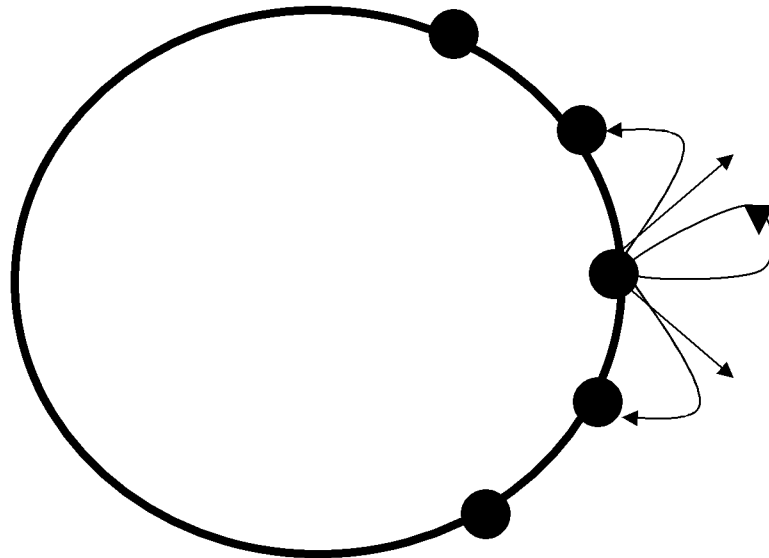

Figure 5.

Quantized Time Domain

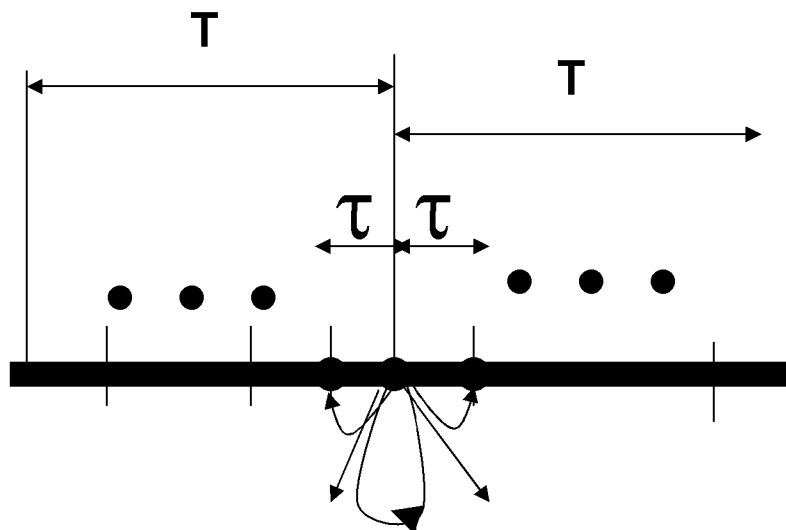

Figure 6.

Example of Trellis Diagram

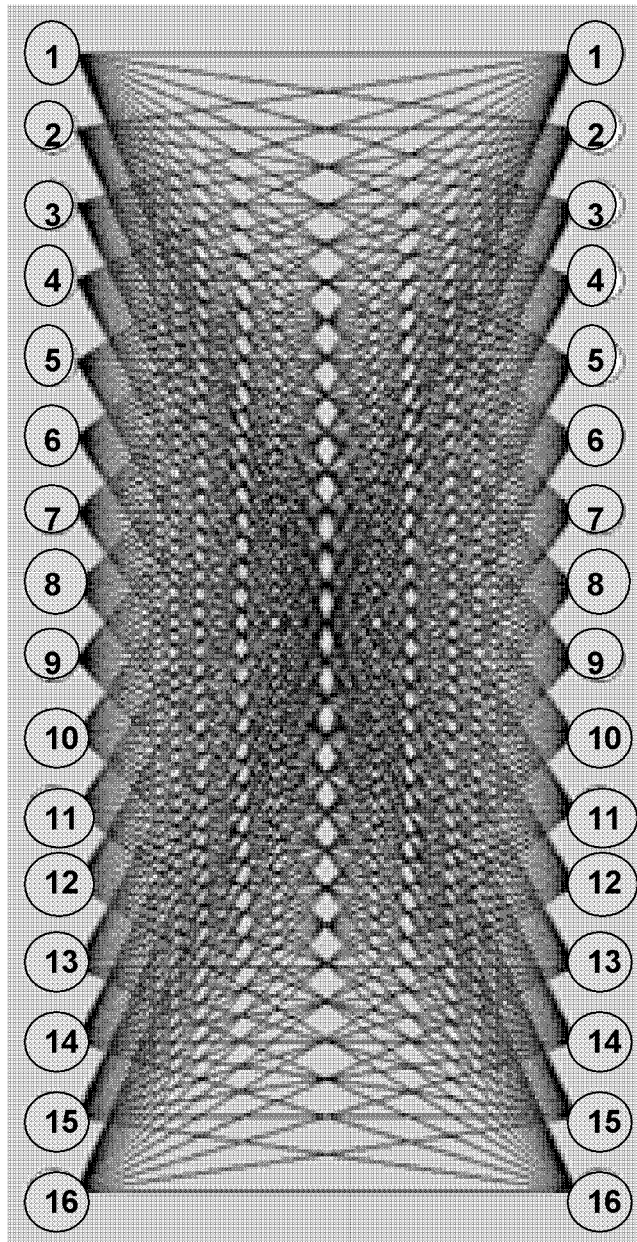
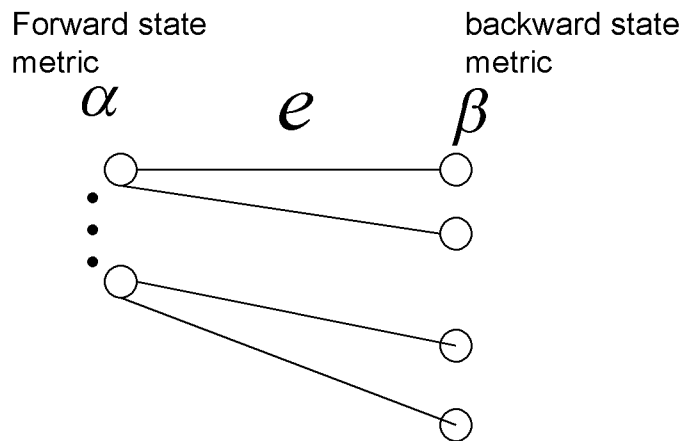
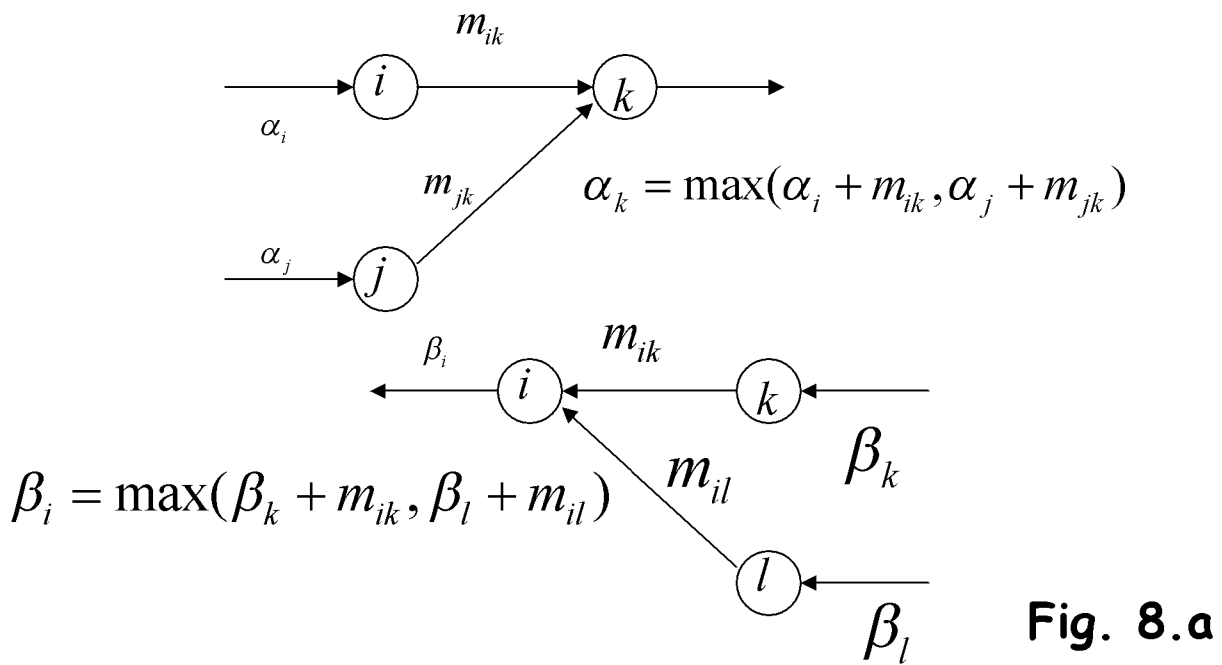

Figure 7.



RFID Channel Code

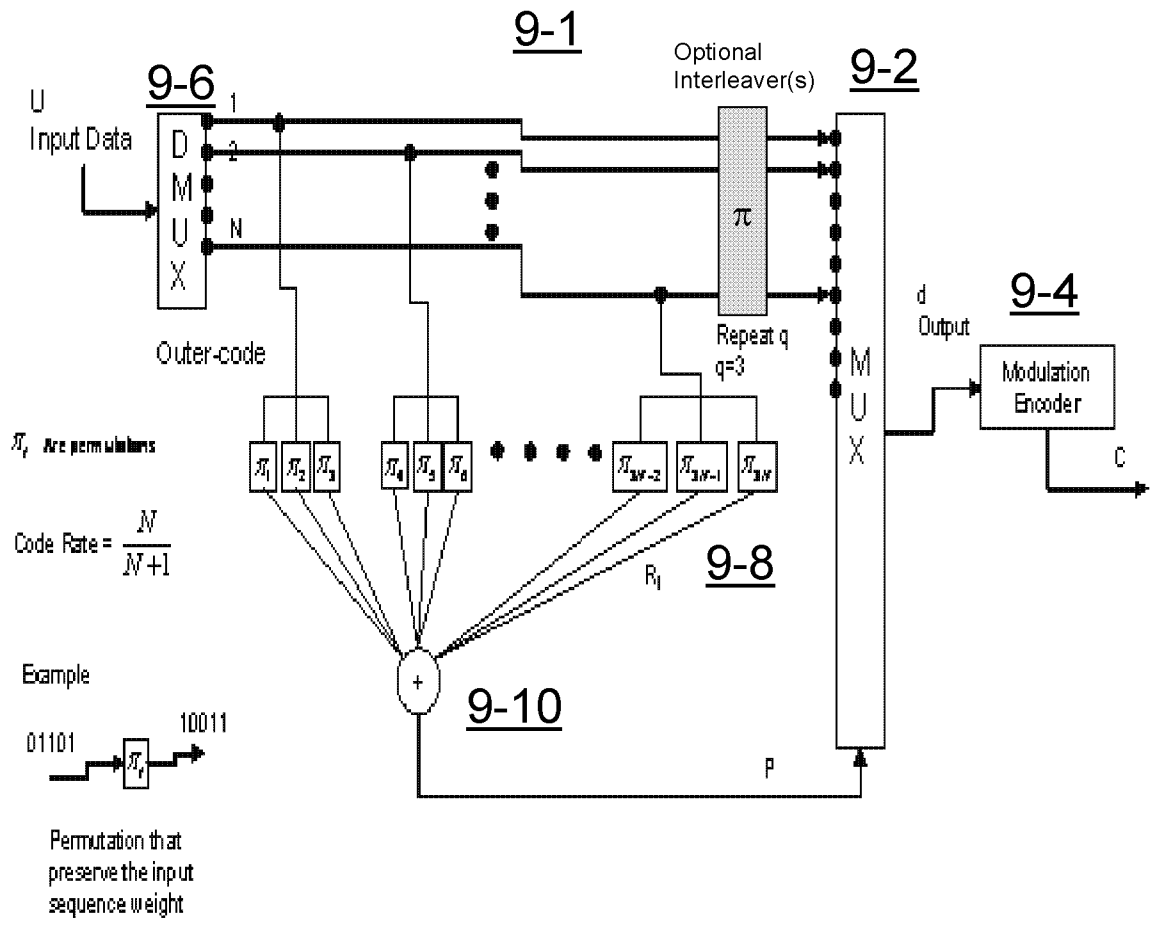

Fig. 9.

RFID Channel SISO Decoder

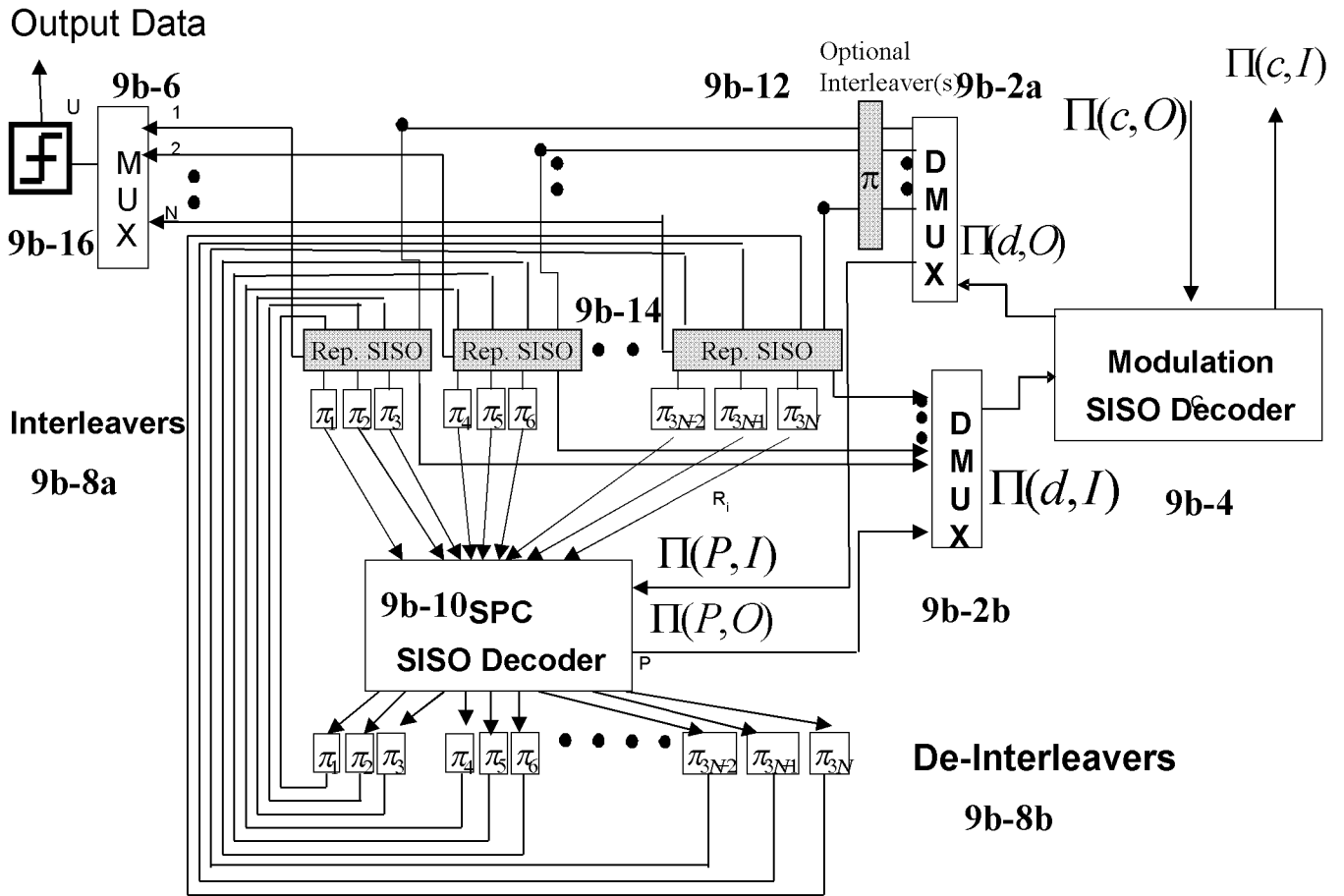
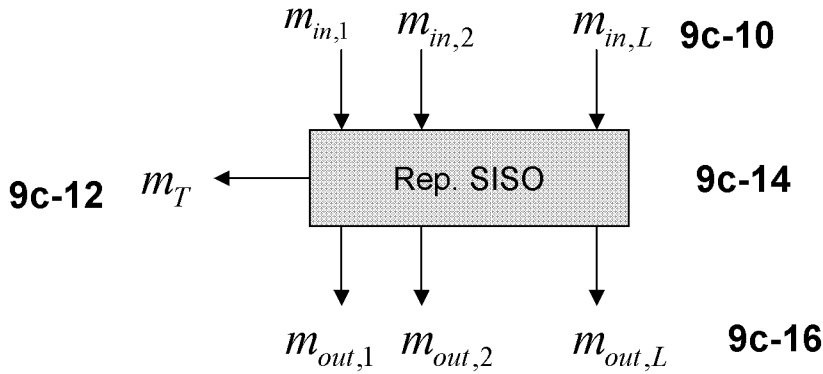

Figure 9b

Repetition L SISO Decoder



$$m_T = \sum_{i=1}^L m_{in,i} \tag{9c-18}$$

$$m_{out,k} = m_T - m_{in,k} \quad k = 1, 2, \dots, L$$

Figure 9c

SPC SISO Decoder With q input one output

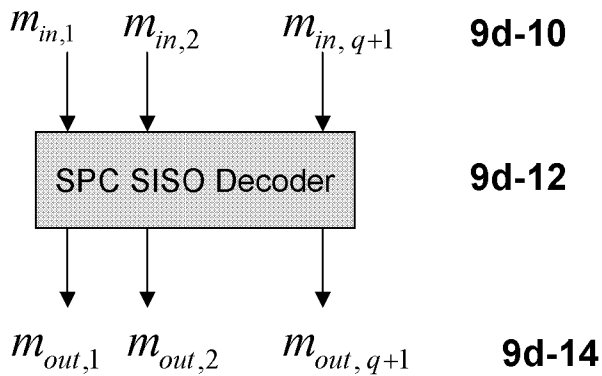

$$m_{out,i} = \alpha \prod_{\substack{j=1 \\ j \neq i}}^{q+1} \text{sign}(m_{in,j}) \min_{\substack{k=1, \dots, q+1 \\ k \neq i}} (|m_{in,k}|) \tag{9d-16}$$

Figure 9d

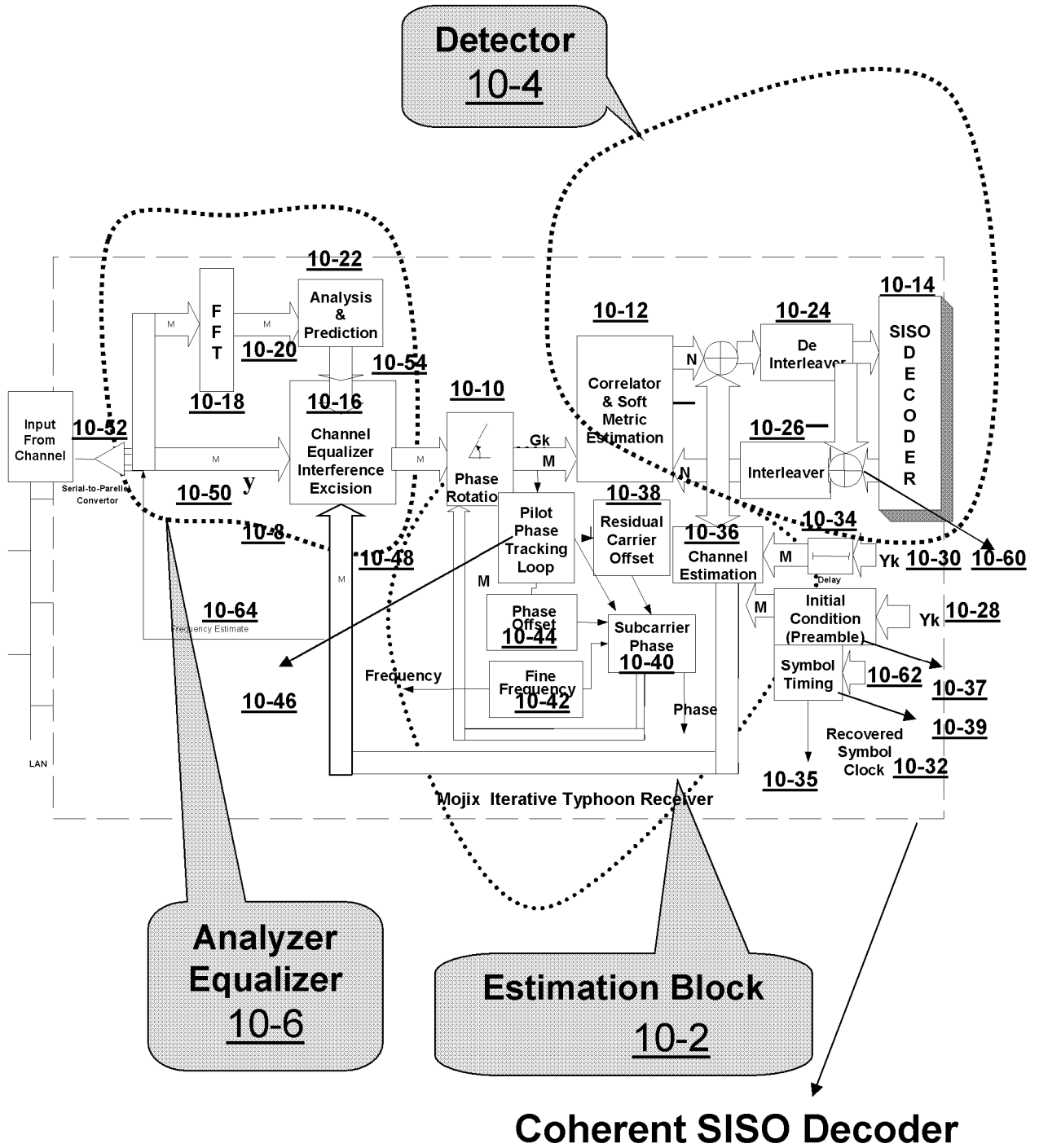

Fig.10

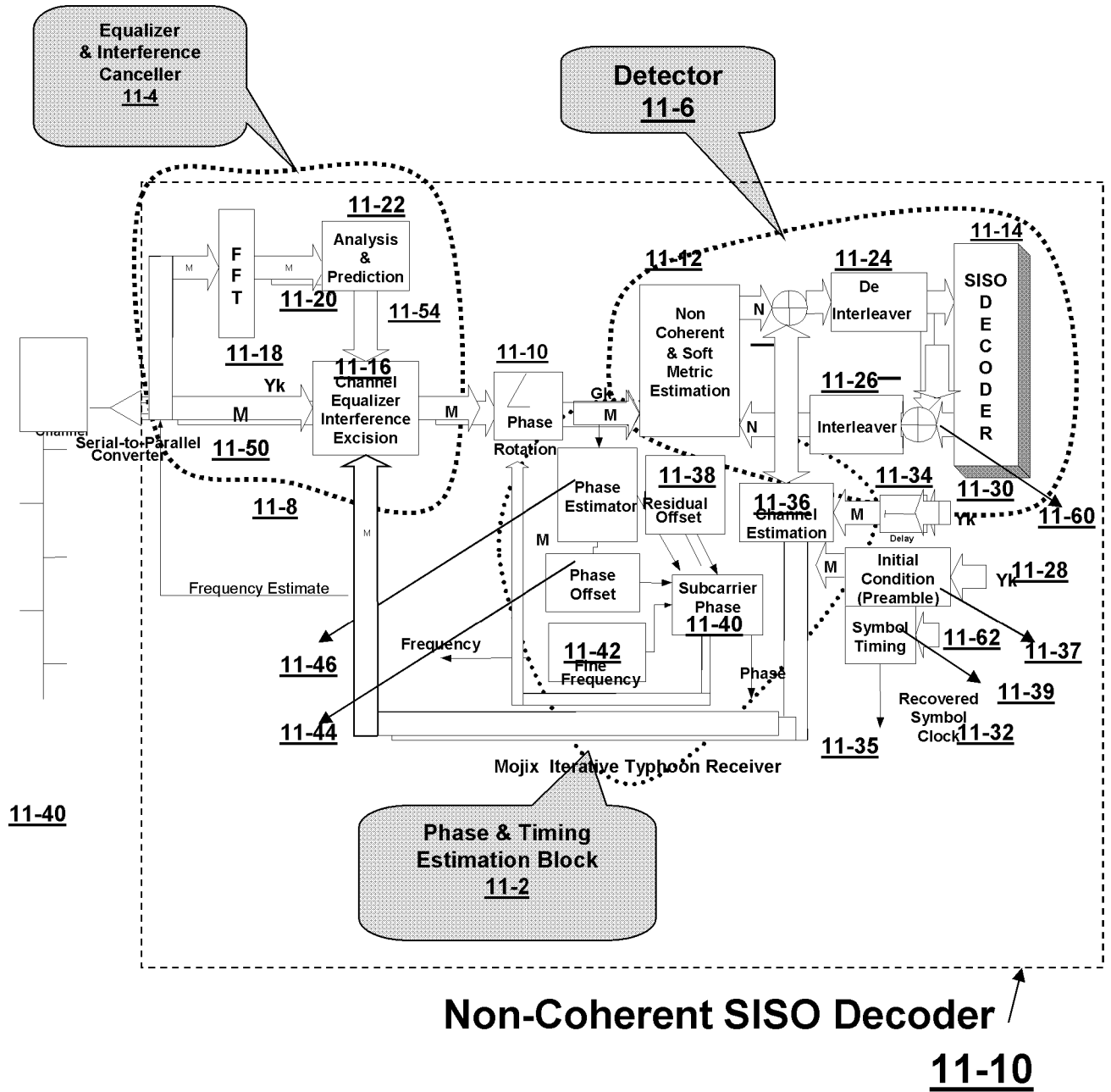
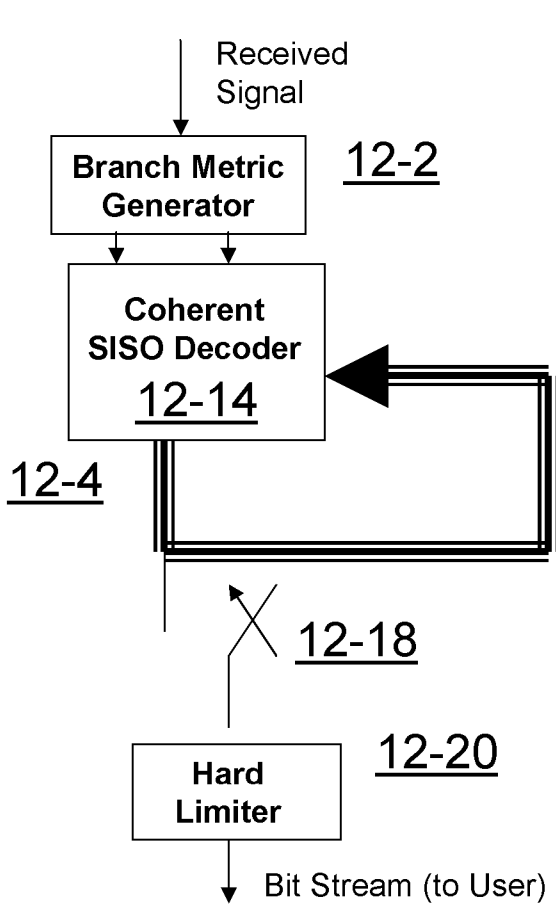

Fig. 11



Coherent SISO Receiver Subsystem
12-10

Fig. 12.a

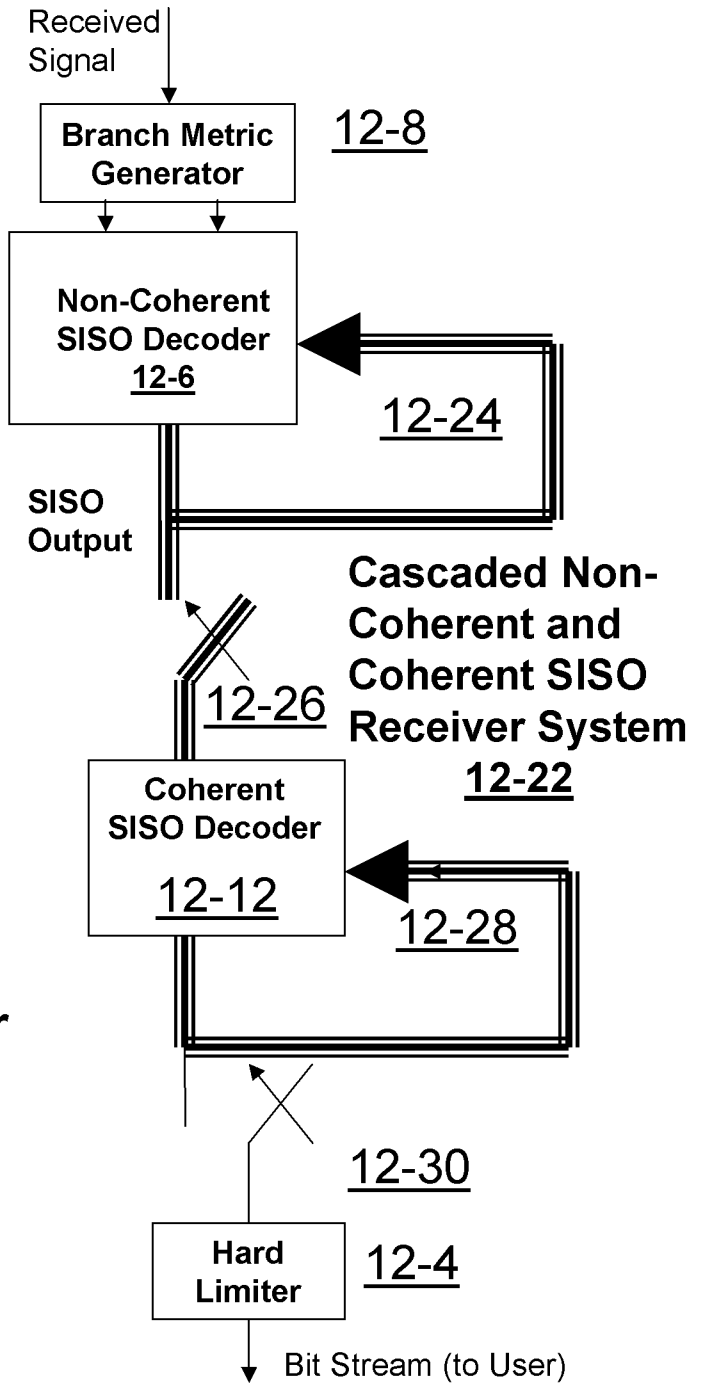

Figure 12.b

Figure 12.

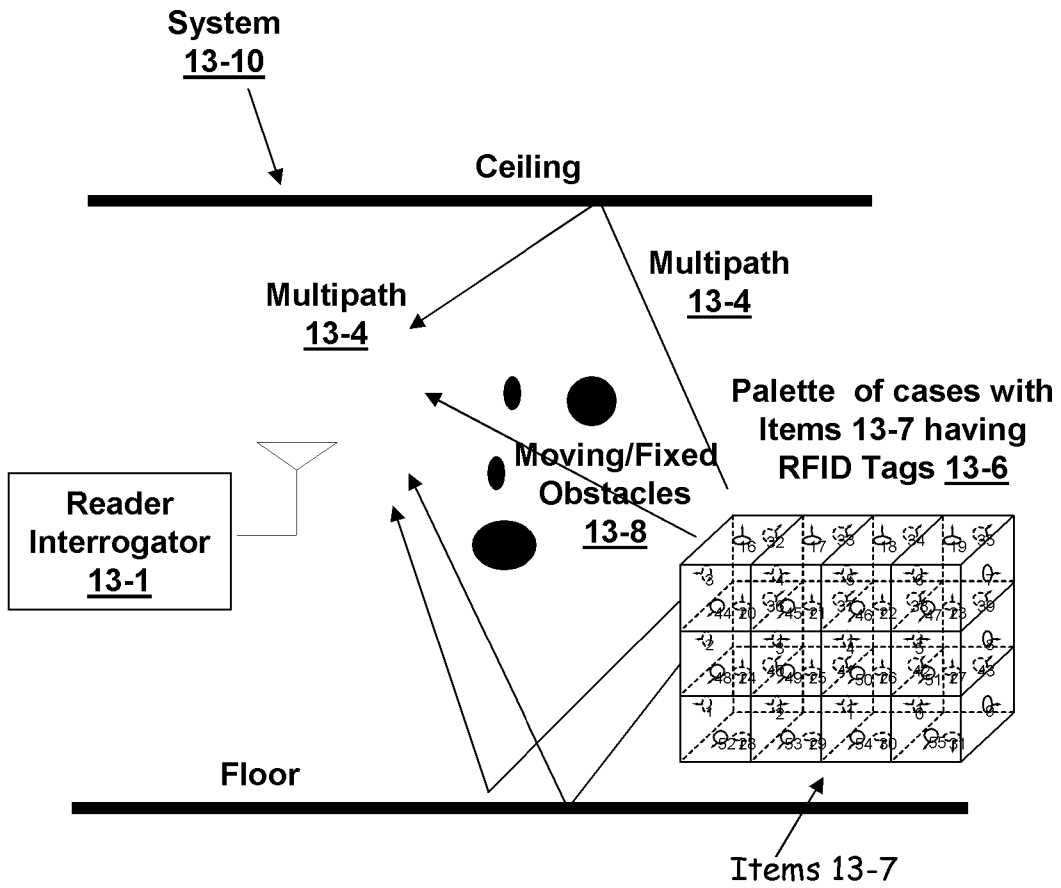

Fig. 13a

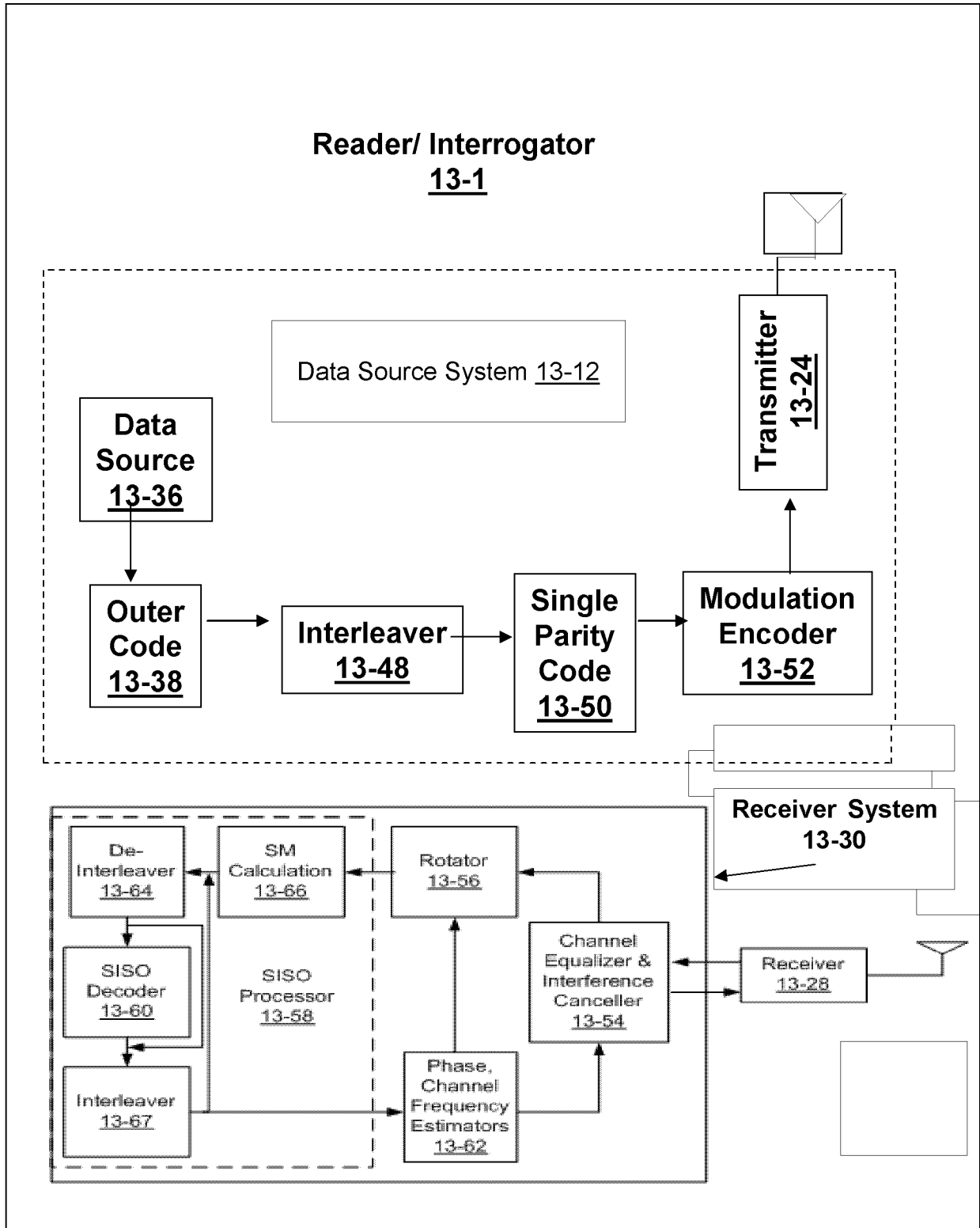

Fig. 13b

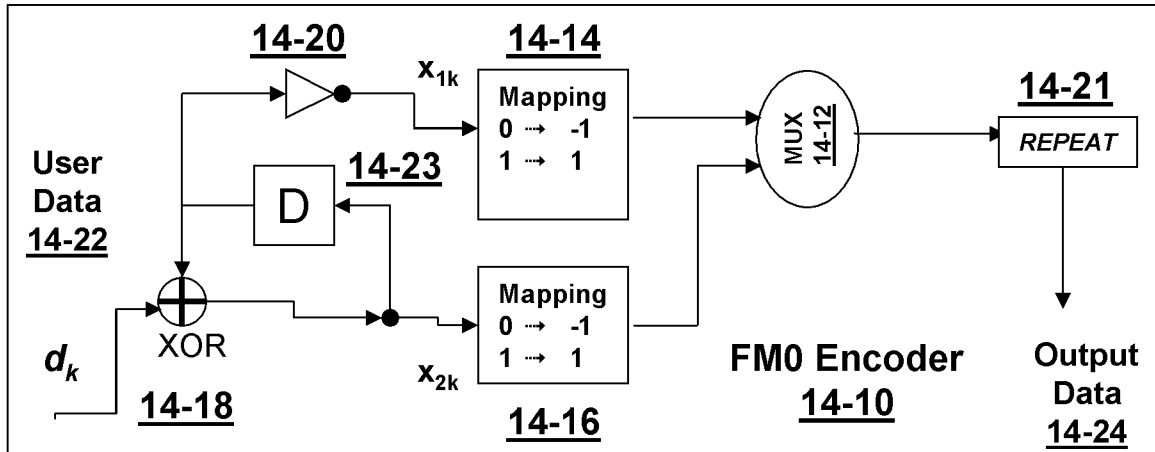

Fig. 14a

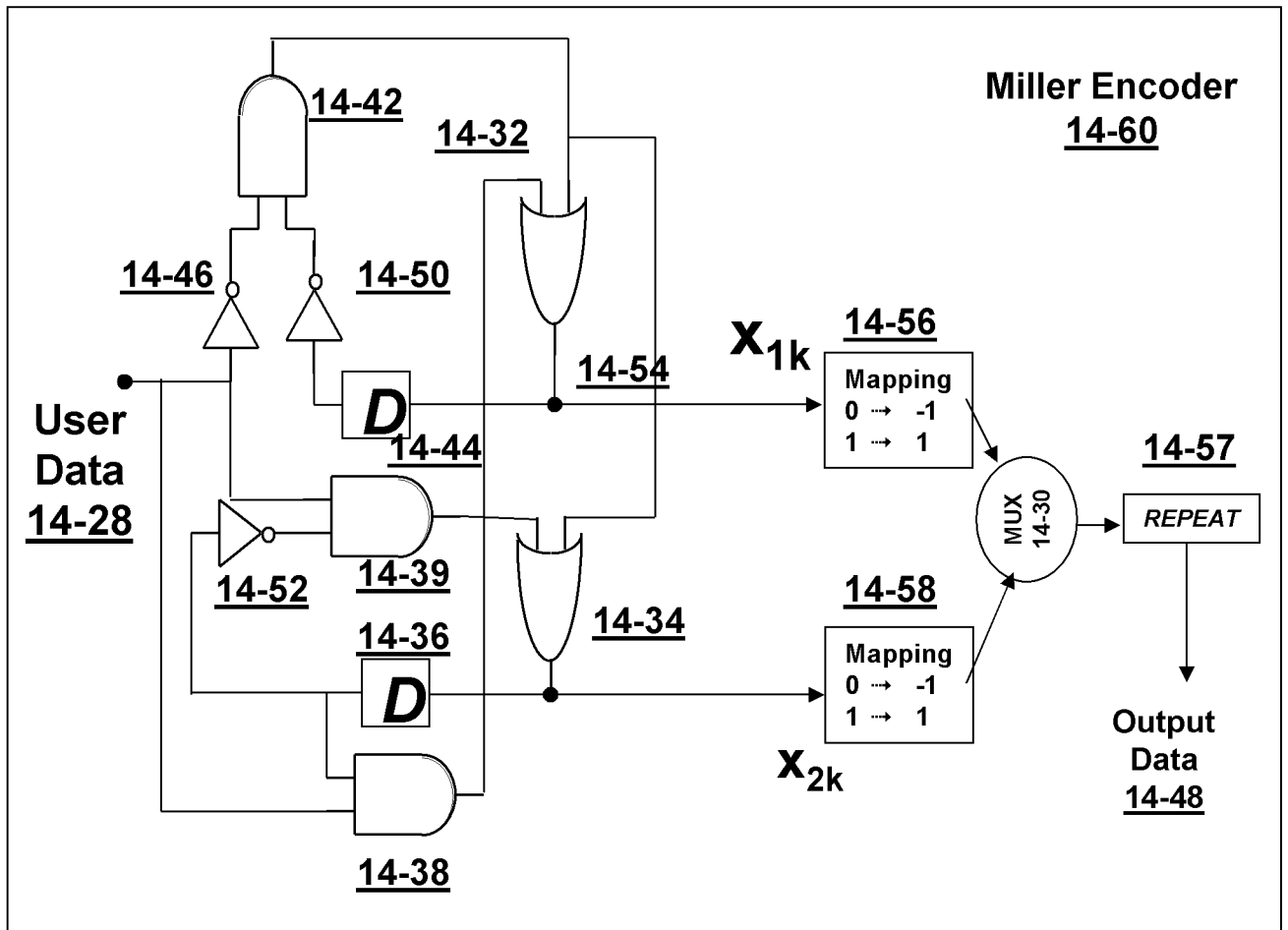

Fig 14.b

Fig. 15a

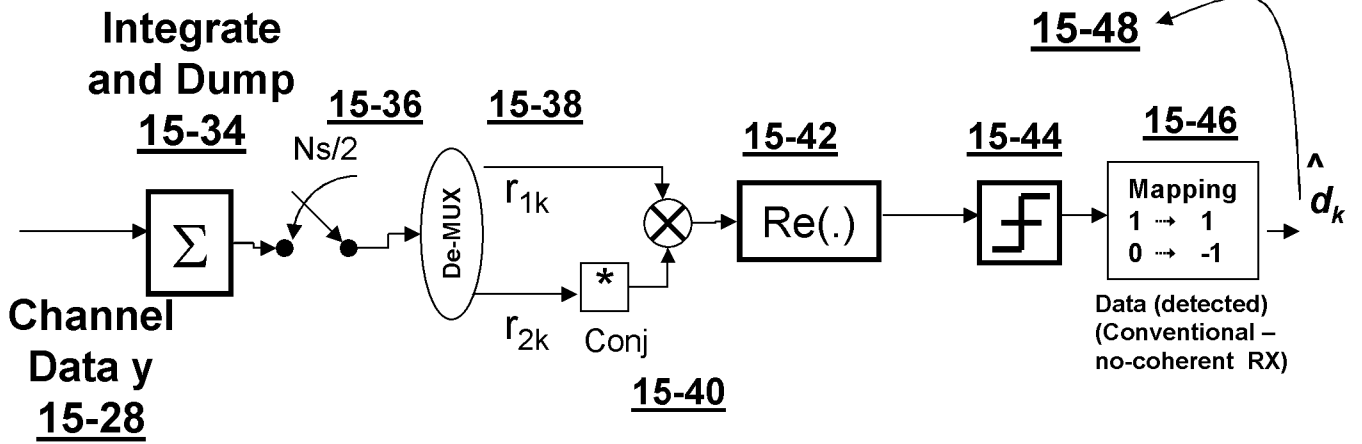

Fig. 15b

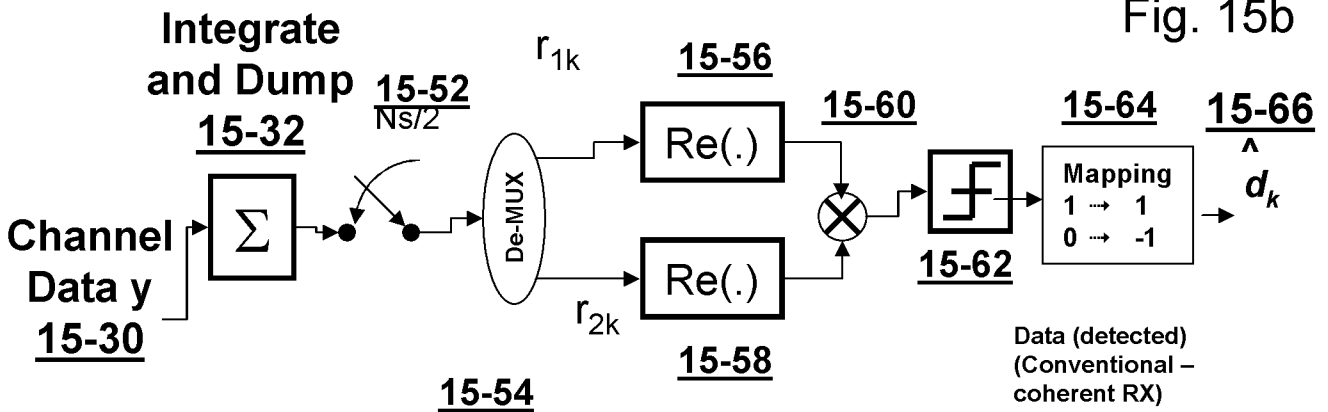
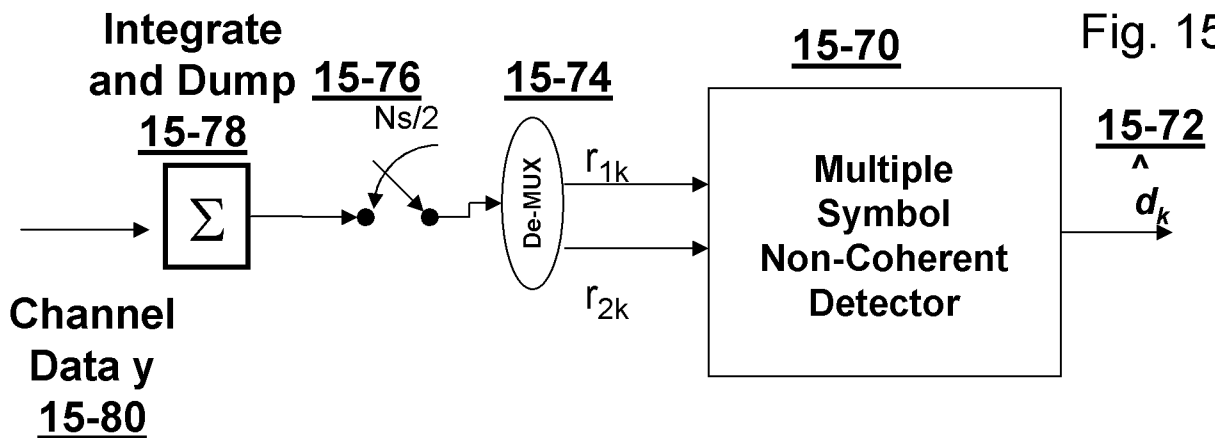
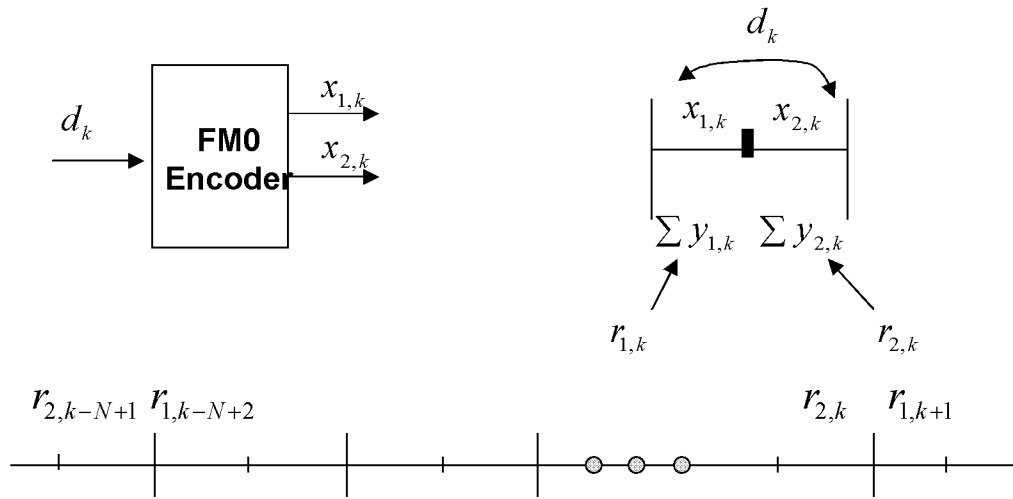

Fig. 15c



FM0 Multi-Symbol Non-Coherent Detection



$$(\hat{d}_k, \hat{d}_{k-1}, \dots, \hat{d}_{k-N}) = \arg \max_{d_k, d_{k-1}, \dots, d_{k-N+2}} \left| (r_{2,k-N+1} - r_{1,k-N+2}) + \sum_{i=k-N+3}^{k+1} (r_{2,i-1} - r_{1,i}) \prod_{j=k-N+2}^{i-1} d_j \right|$$

For N=3:

$$(\hat{d}_{k-1}, \hat{d}_k) = \arg \max_{d_{k-1}, d_k} \left| (r_{2,k-2} - r_{1,k-1})d_{k-1} + (r_{2,k-1} - r_{1,k}) + (r_{2,k} - r_{1,k+1})d_k \right|$$

Figure 15d

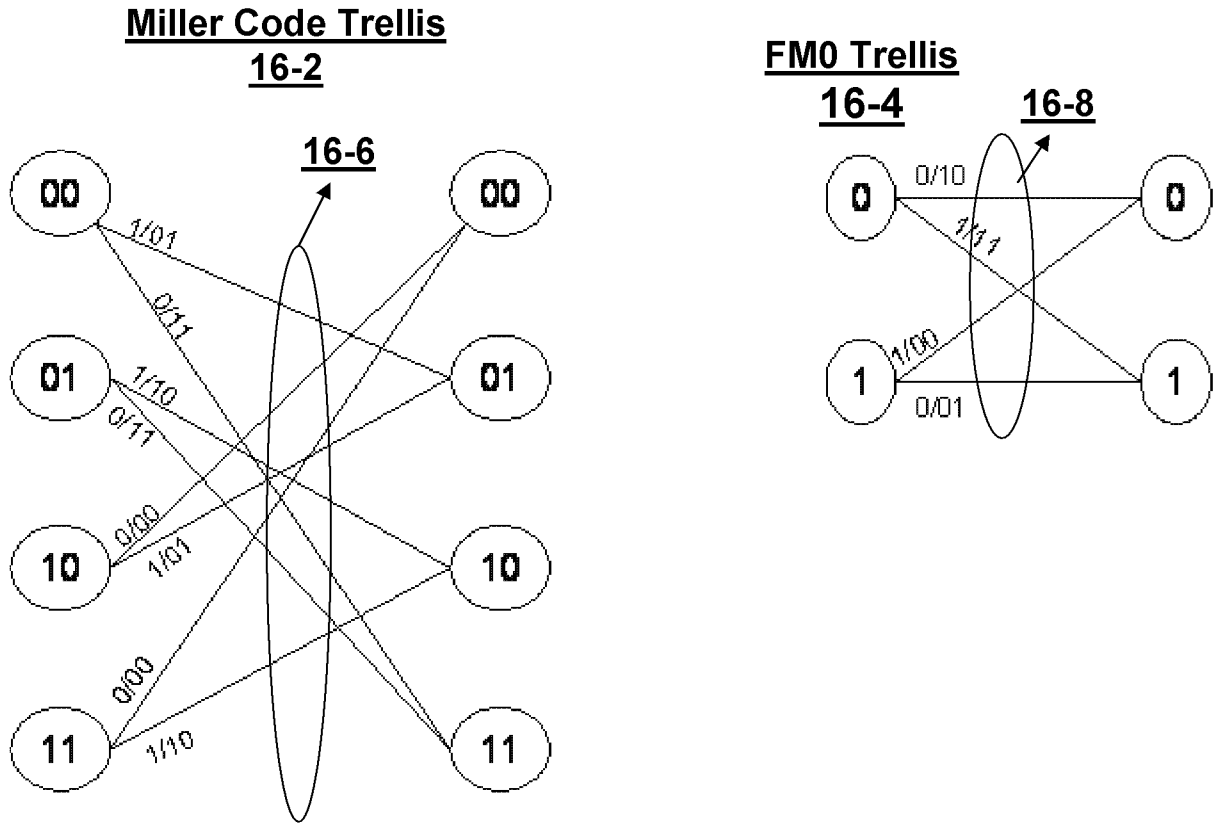

Figure 16

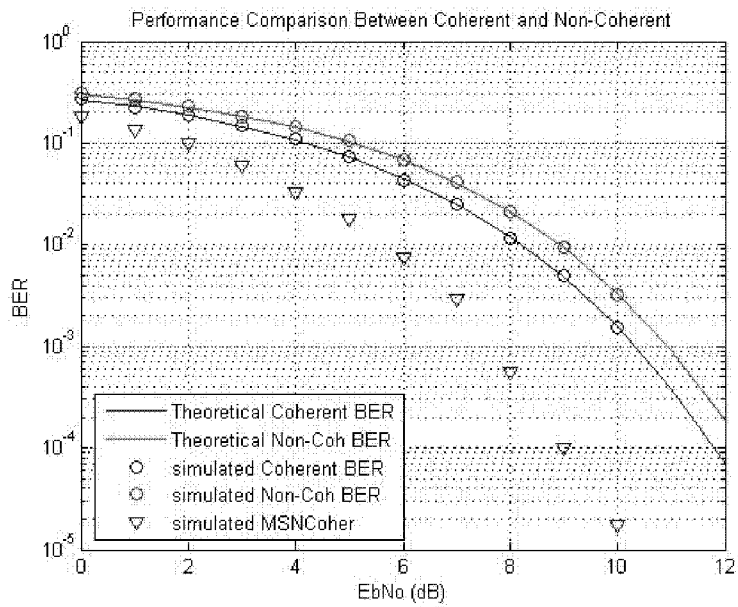

Figure 17

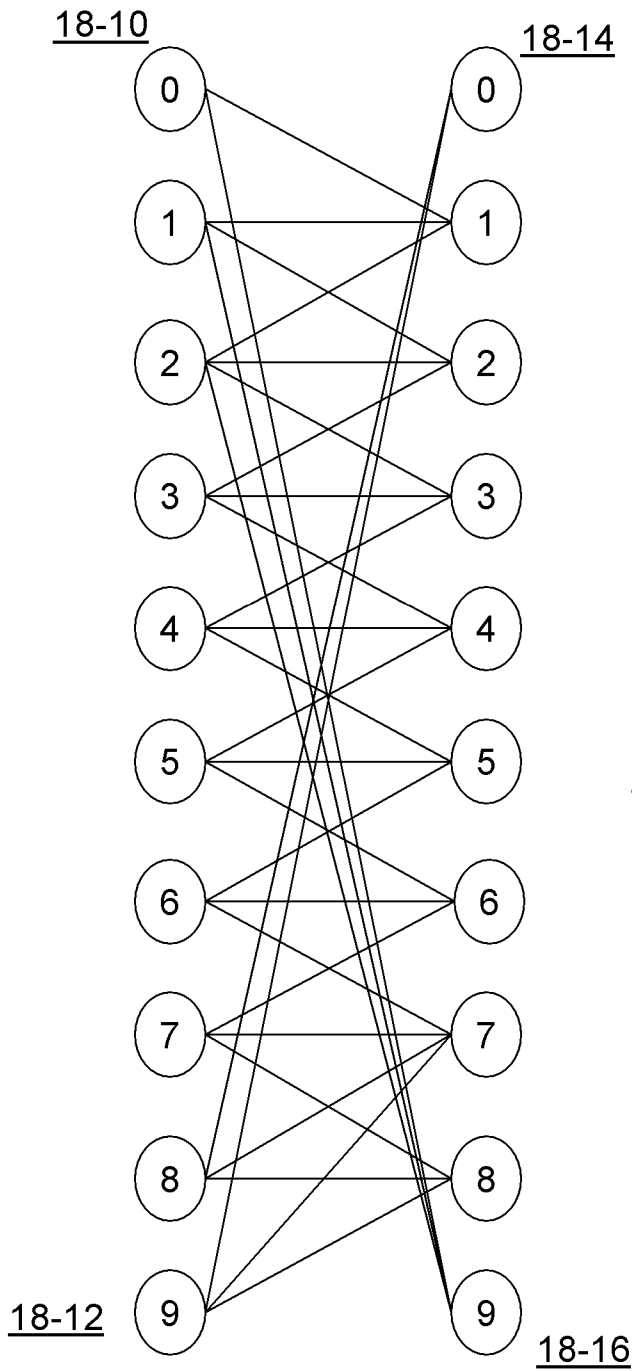

Figure 18

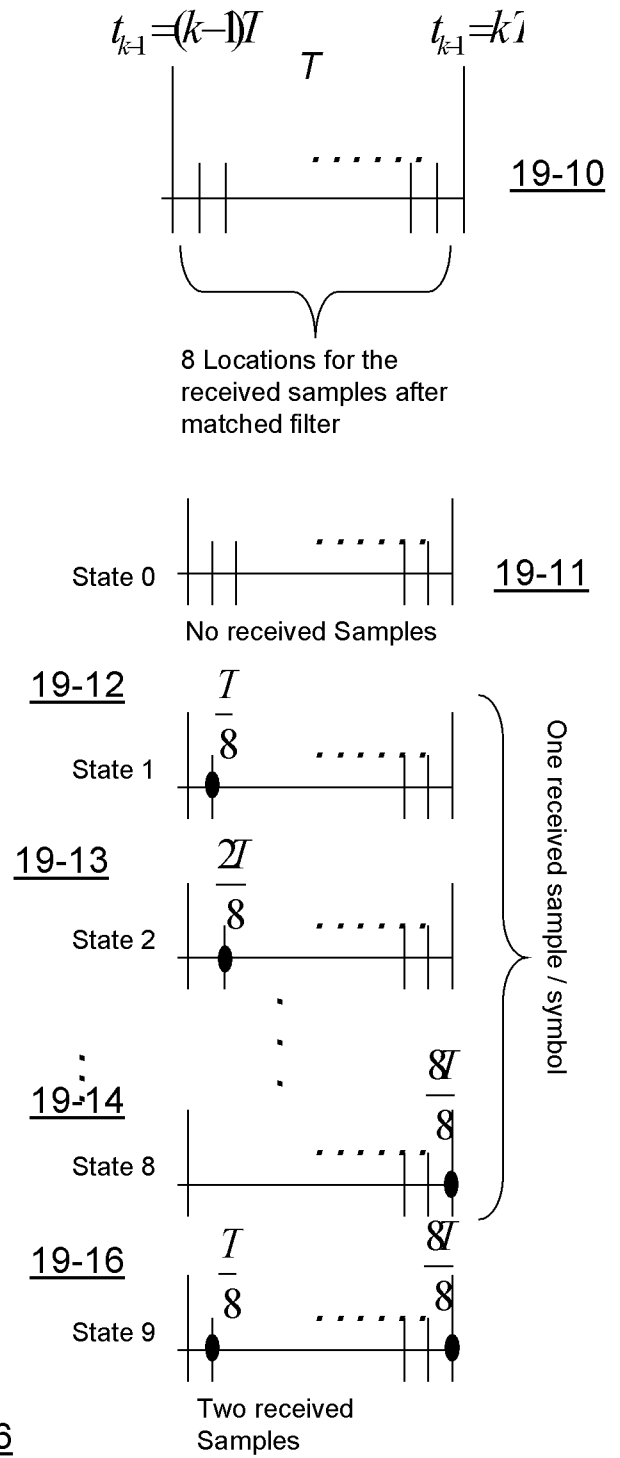
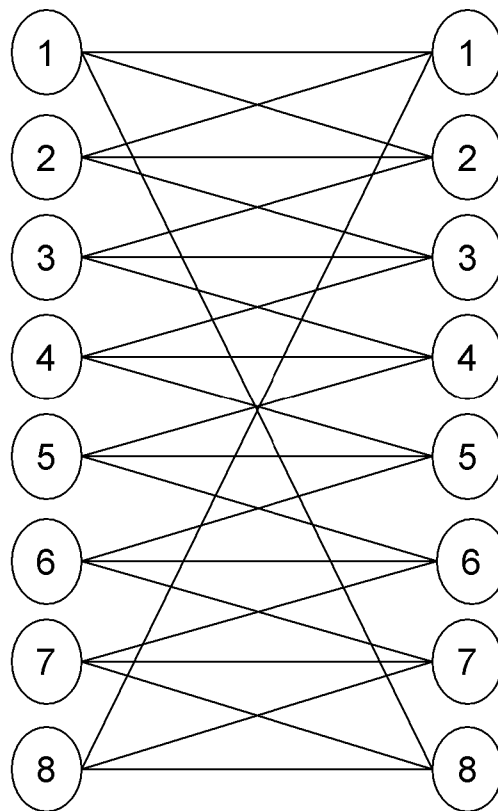

Figure 19

20-10

20-14



20-12

20-16

Figure 20

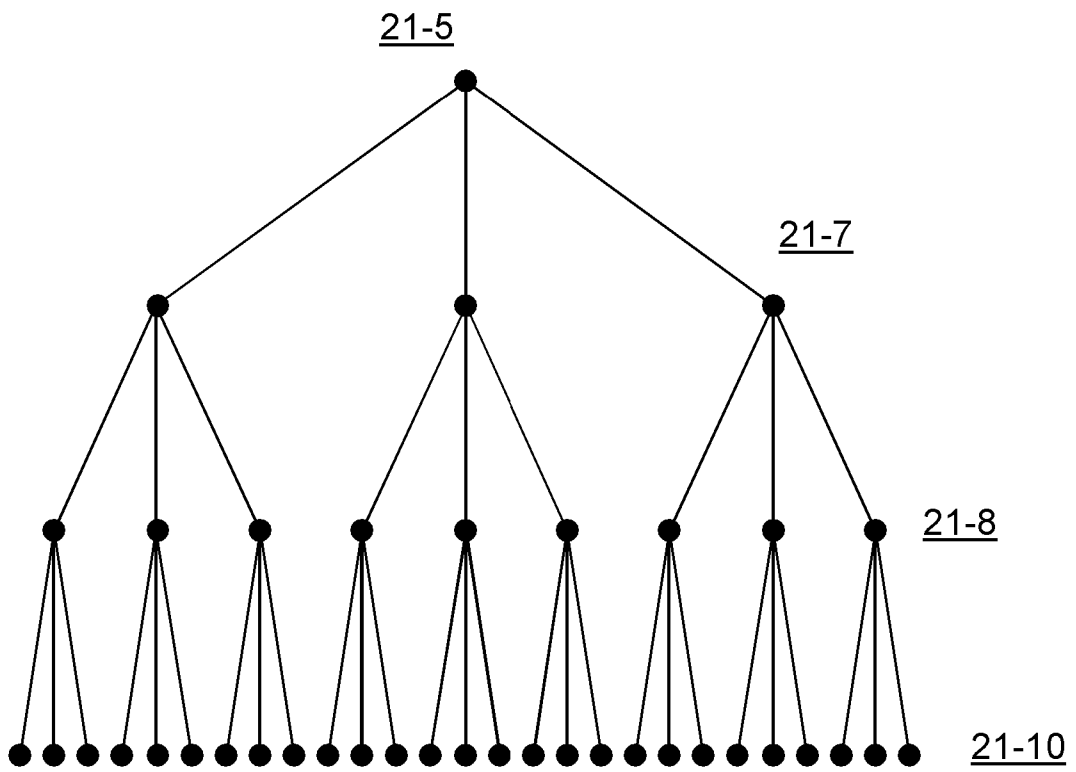
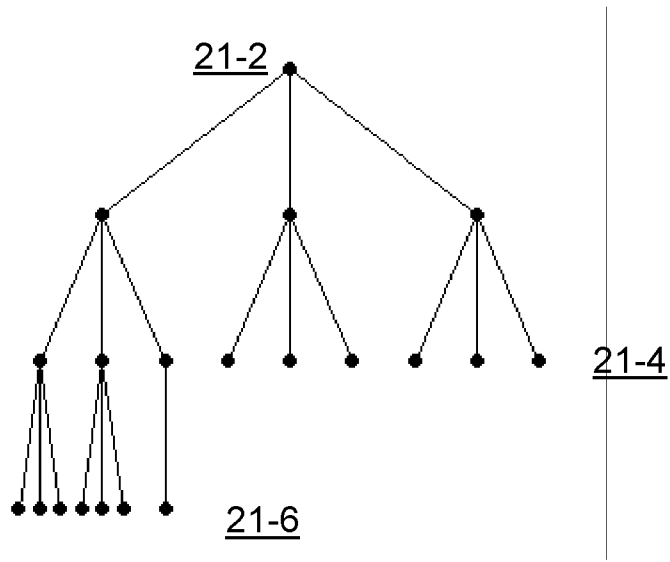

Figure 21

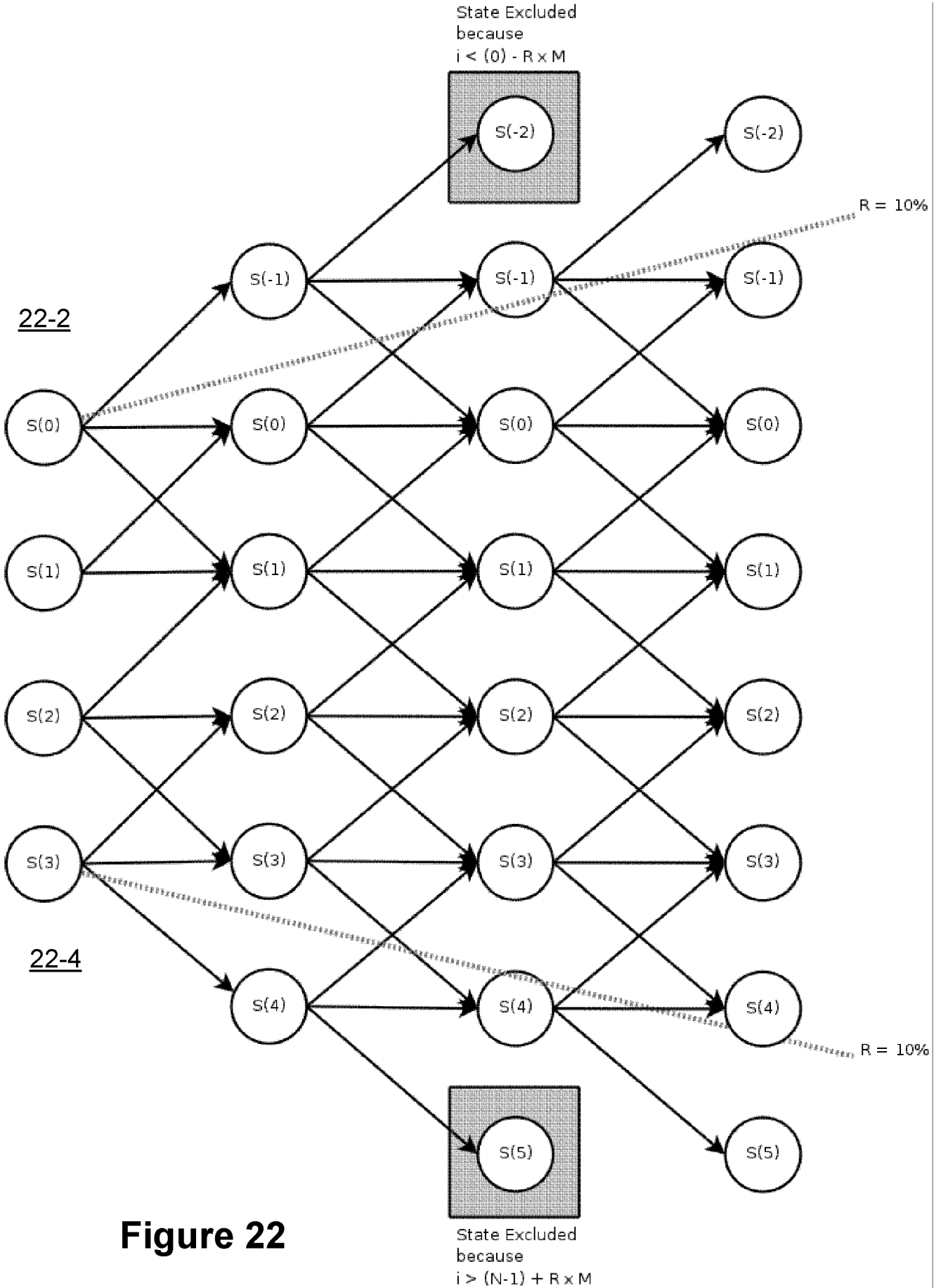

Figure 22

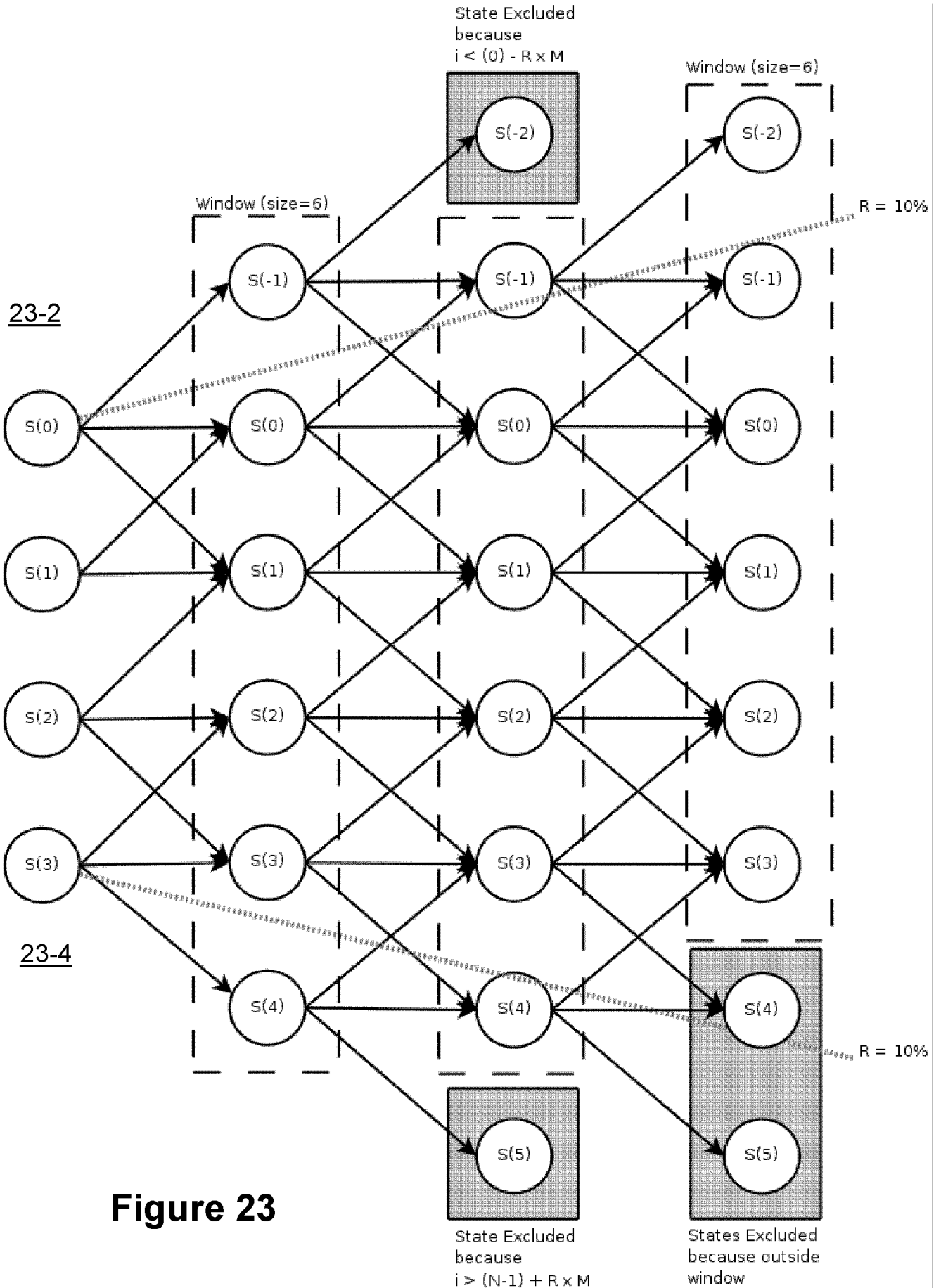

Figure 23

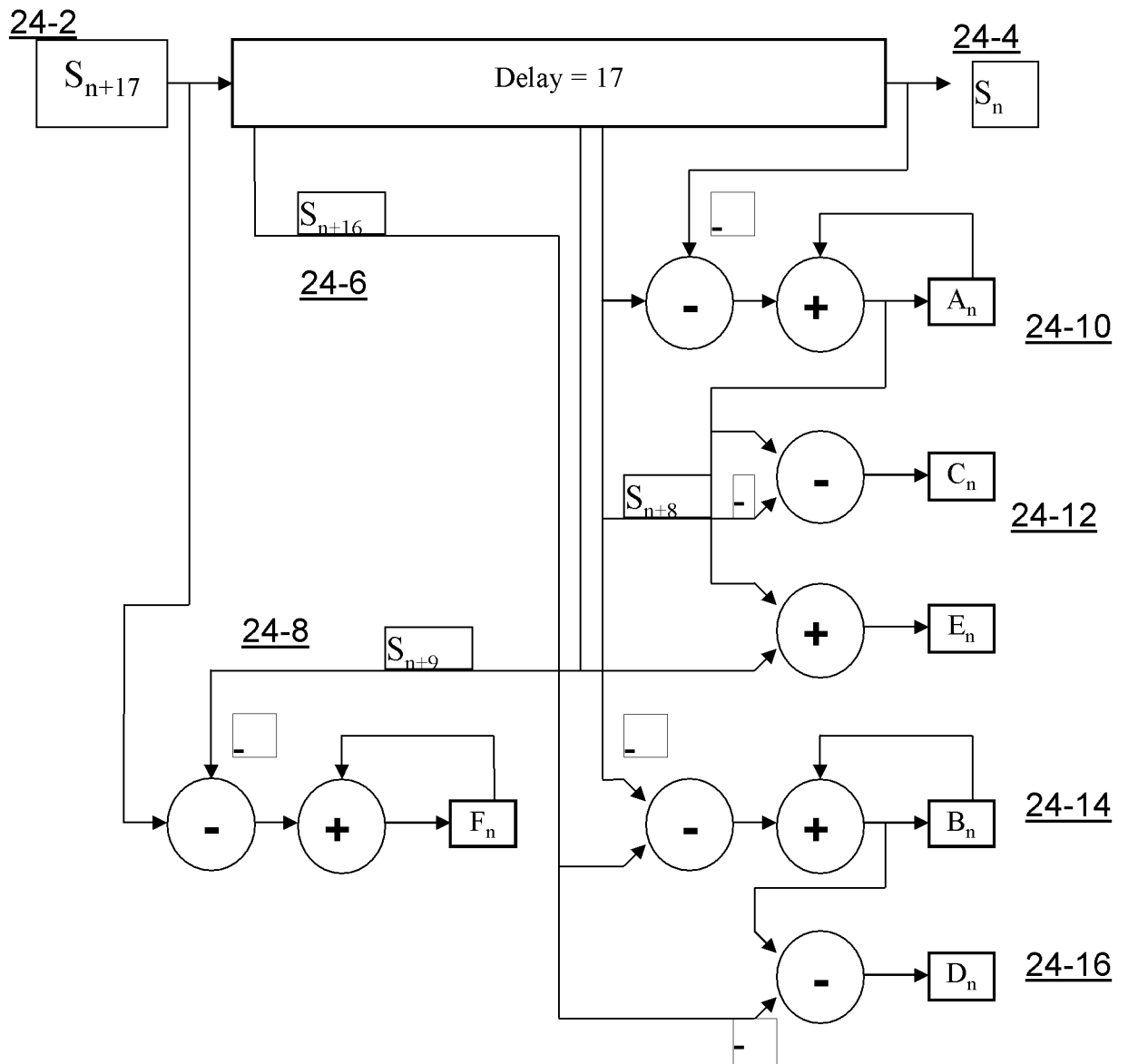

Figure 24

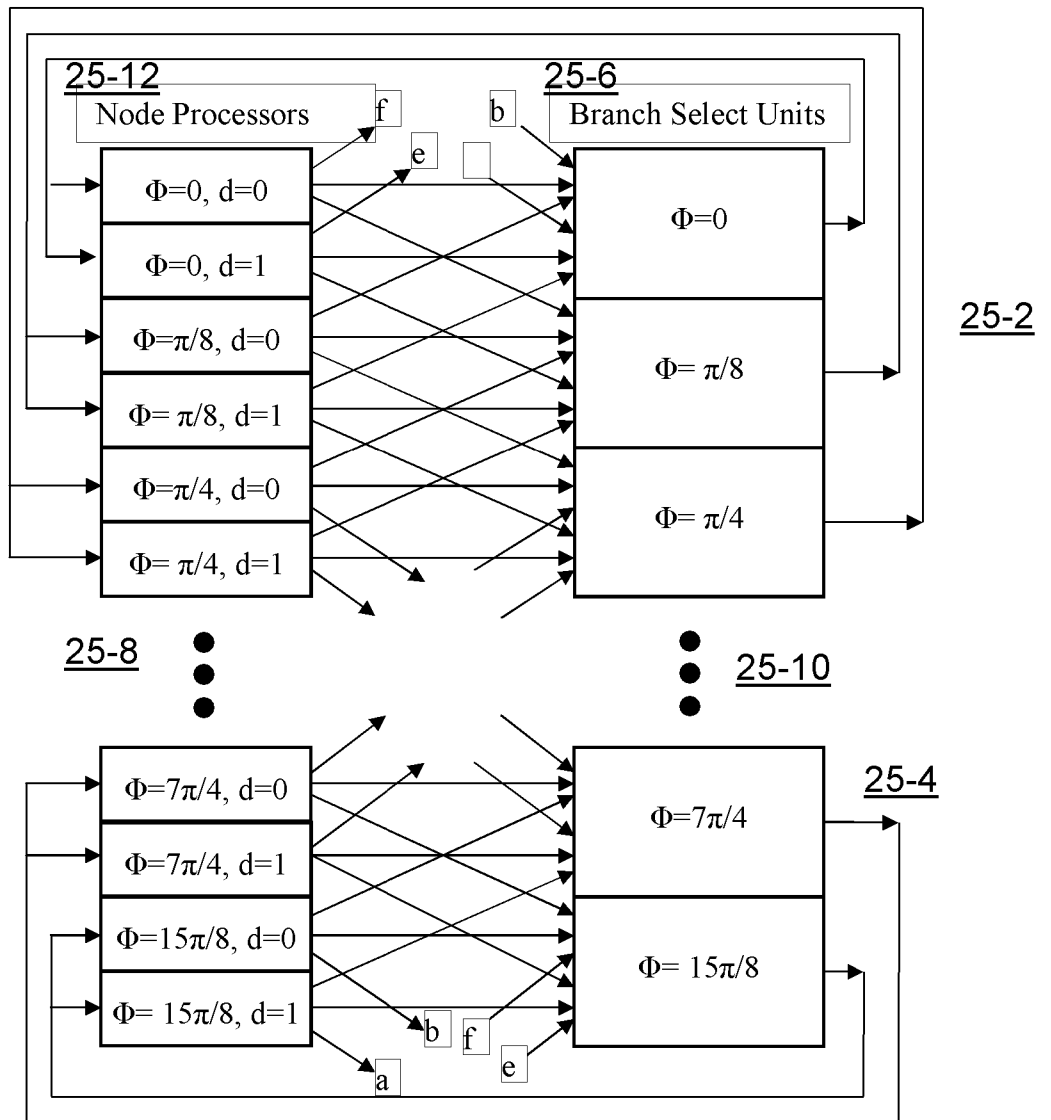

Figure 25

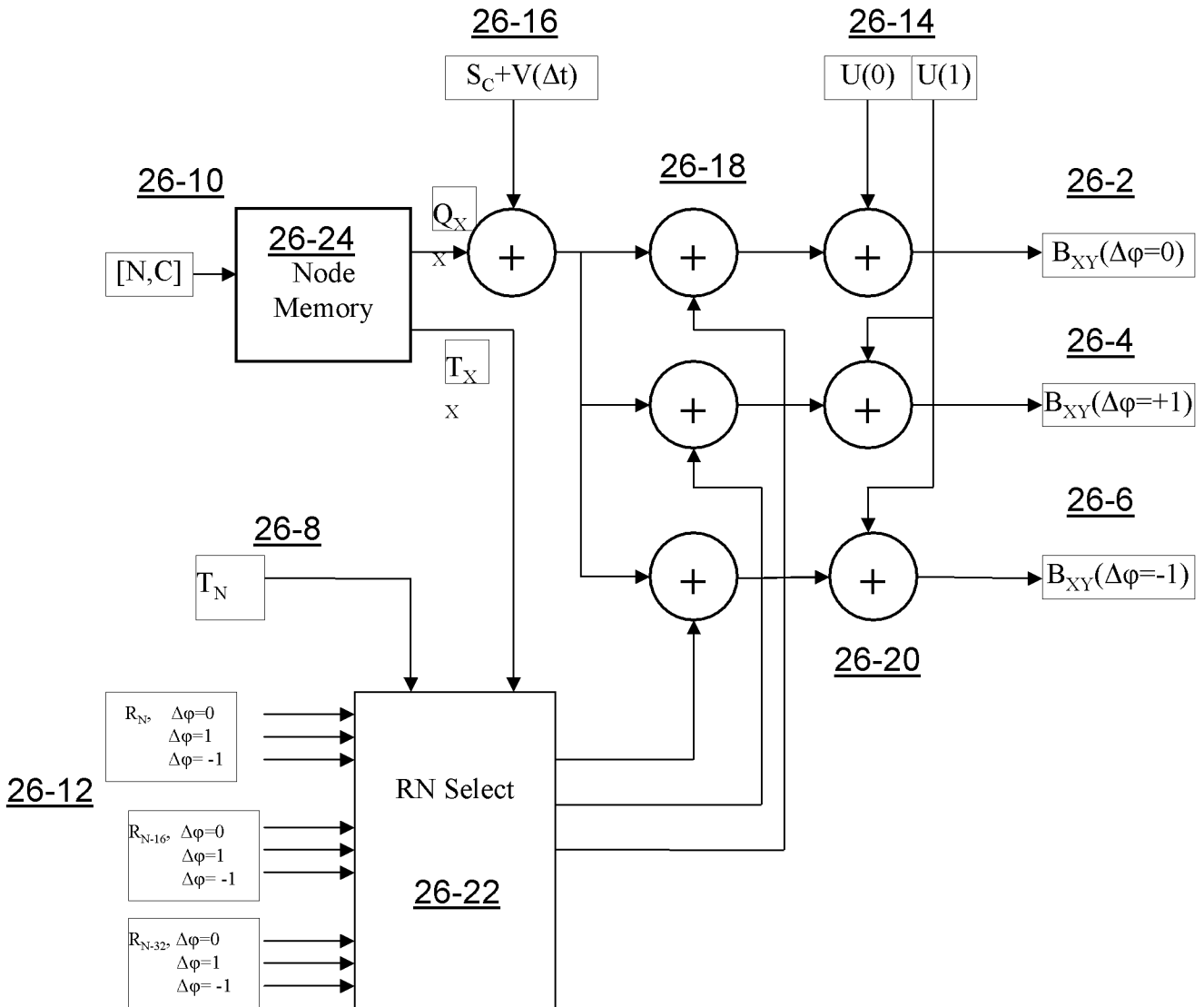

Figure 26

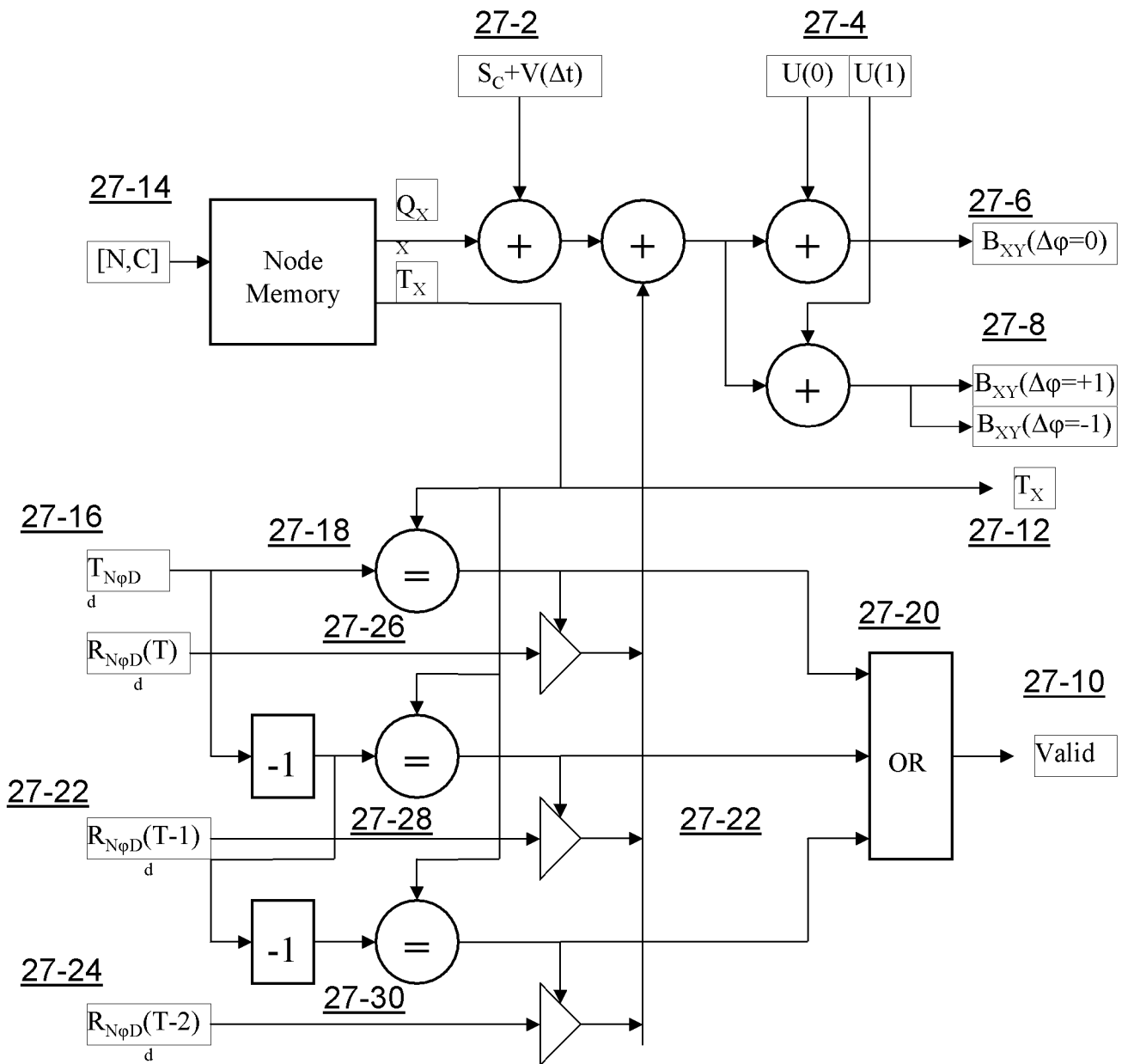

Figure 27