



US 20040046090A1

(19) **United States**

(12) **Patent Application Publication**

Kao

(10) **Pub. No.: US 2004/0046090 A1**

(43) **Pub. Date: Mar. 11, 2004**

(54) **METHOD OF MANUFACTURE WRIST PAD**

(52) **U.S. Cl. 248/118.1; 248/118; 248/918**

(76) **Inventor: Semi Kao, Chang-Hua Hsien (TW)**

(57) **ABSTRACT**

Correspondence Address:

**DENNISON, SCHULTZ & DOUGHERTY
612 Crystal Square 4
1745 Jefferson Davis Highway
Arlington, VA 22202-3417 (US)**

A method of manufacture a wrist pad, comprising the step of: a. Knead and stir a mixture having natural rubber and foaming agent repeatedly to make it well mix. b. Press the well mixed mixture into a plank element. c. Form an arched portion on the plank element. d. Foam the plank element with the arched portion so that chemical reaction will occur between the natural rubber and the foaming agent to produce an air pressure for forming the plank element to a wrist pad, and c. Cool the foamed wrist pad and cut the wrist pad into a predetermined shape.

(21) **Appl. No.: 10/235,659**

(22) **Filed: Sep. 6, 2002**

Publication Classification

(51) **Int. Cl.⁷ B68G 5/00**

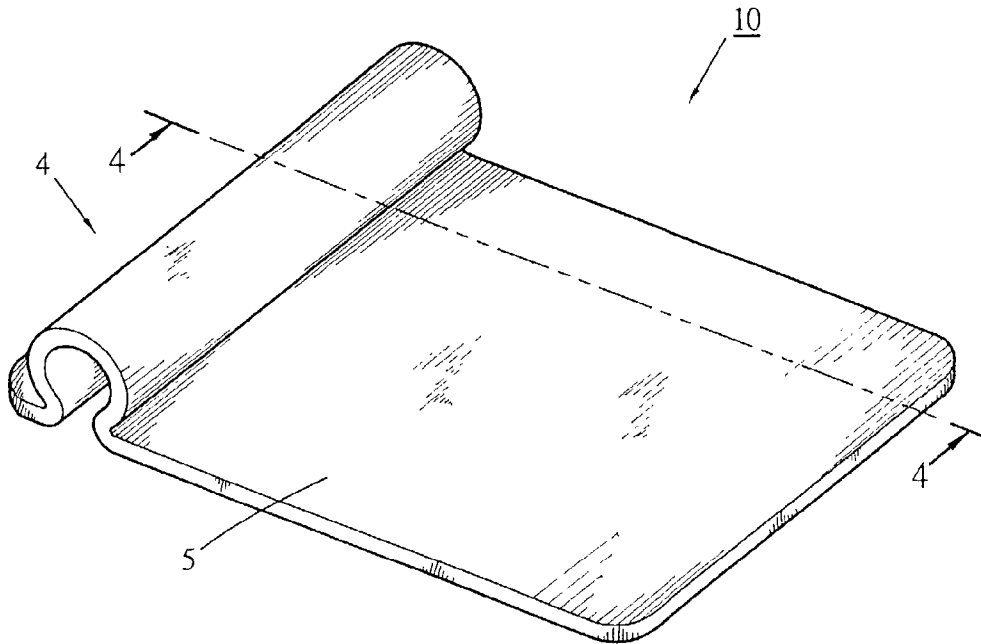

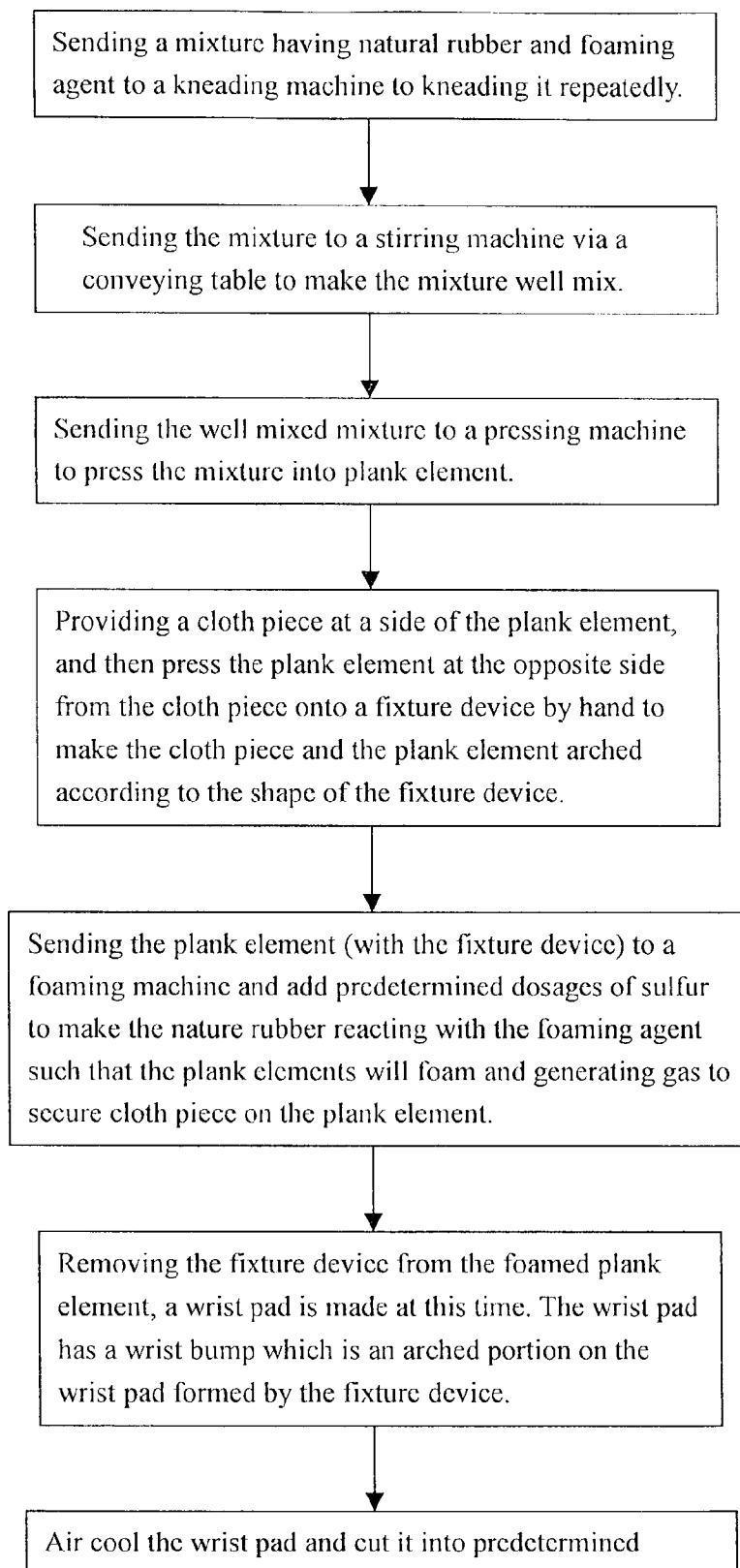

FIG.1

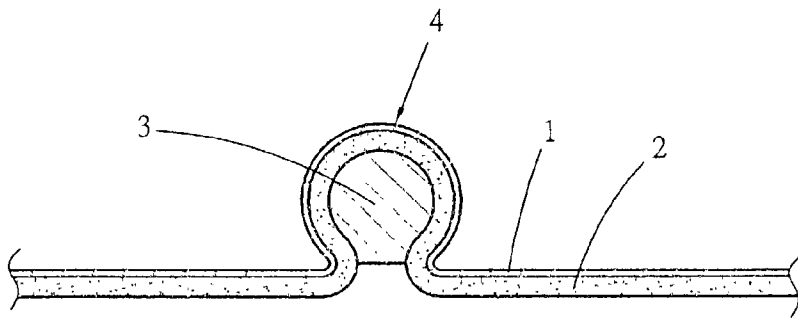

FIG. 2

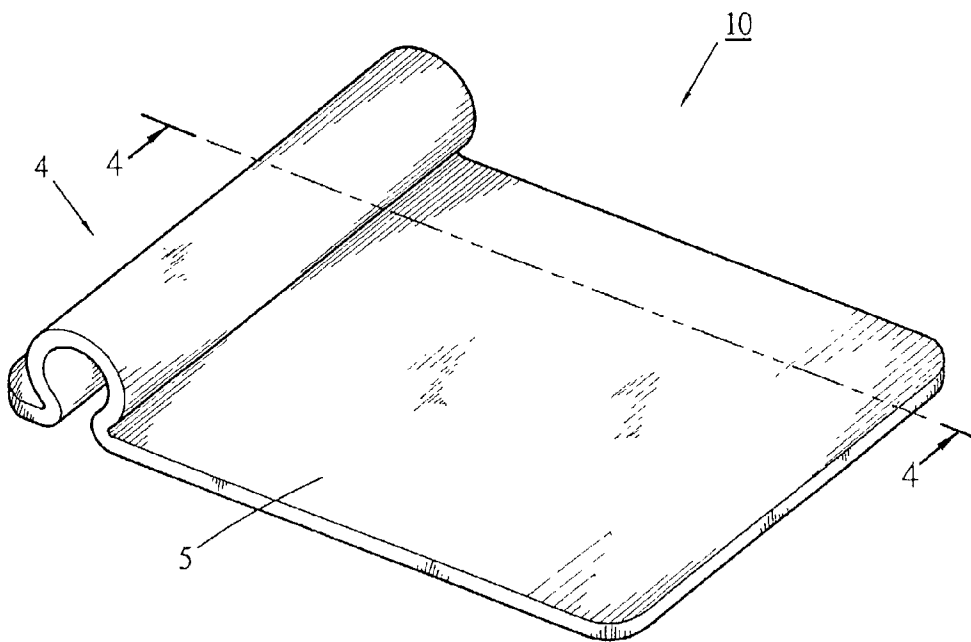

FIG. 3

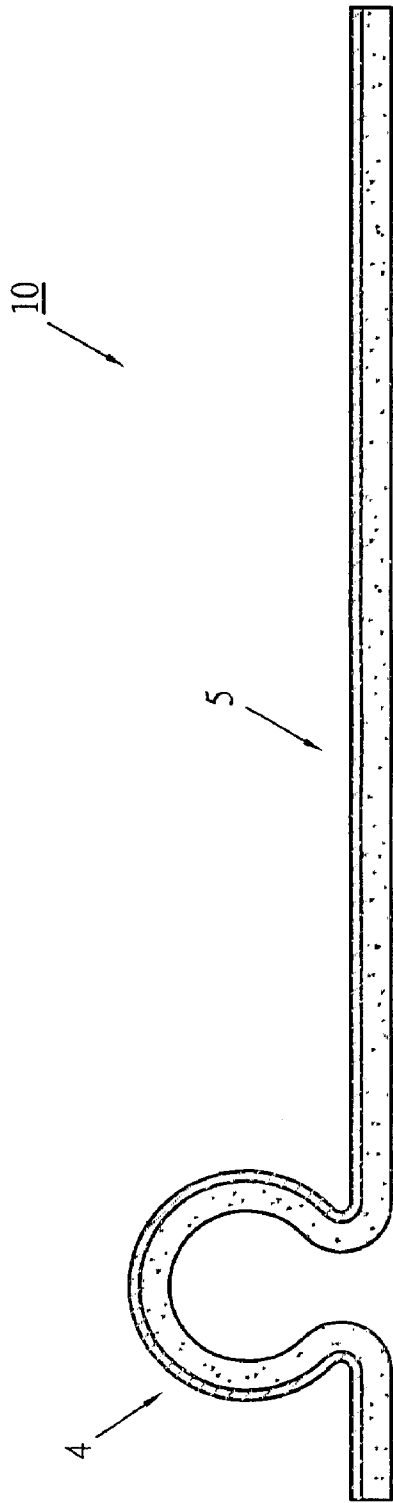

FIG.4

METHOD OF MANUFACTURE WRIST PAD

FIELD OF THE INVENTION

[0001] The present invention relates generally to a computer applied product, and more particularly to a wrist pad.

BACKGROUND OF THE INVENTION

[0002] In prior art, a wrist pad or a mouse pad was made from a foamed material, such as PU, EVA or foam, molded in a mold with a cloth piece attached on the surface thereof by glue. In present market, plenty of wrist pads with different shapes were brought to consumers. The shape of the wrist pad is corresponding to the cavity of the mold such that if one wanted to manufacture wrist pads with different shapes, one must have different molds to manufacture them or one must change the shape of the cavity of the mold to meet the shape one wanted.

[0003] In conclusion, if a manufacturer wants to manufacture wrist pads with different shapes, he/she must have plenty of molds with different cavities. There will be a larger cost to prepare these molds.

[0004] In addition, the conventional wrist pad was provided with a wrist bump thereon to support user's wrist. The wrist bump is inserted a soft material, such as foam, therein, it can not support the wrist in a fully supporting.

SUMMARY OF THE INVENTION

[0005] The primary objective of the invention is to provide a wrist pad, which has no mold in the processes to manufacture it and can manufacture the wrist pads with different shapes.

[0006] According to the objectives of the invention, a method of manufacture a wrist pad, comprising the step of: a. Knead a mixture having natural rubber and foaming agent repeatedly to make it well mix. b. Press the well mixed mixture into a plank element. c. Form an arched portion on the plank element. d. Foam the plank element with the arched portion so that chemical reaction will occur between the natural rubber and the foaming agent to produce an air pressure for forming the plank element to a wrist pad, and e. Cool the foamed wrist pad and cut the wrist pad into a predetermined shape.

[0007] According to the method, the wrist pad has a flat portion and a wrist bump thereon which is the arched portion.

BRIEF DESCRIPTION OF THE DRAWINGS

[0008] FIG. 1 is a flow chart of a prefer embodiment of the present invention;

[0009] FIG. 2 is a lateral view of a piece element with a wrist bump thereon;

[0010] FIG. 3 is a perspective view of a wrist pad, which is made from the method of the prefer embodiment of the present invention, and

[0011] FIG. 4 is a sectional view along the 4-4 line in FIG. 3.

DETAIL DESCRIPTION OF THE INVENTION

[0012] Please refer to FIG. 1, a method to manufacture a wrist pad of the present invention comprises the steps of:

[0013] First step is that sends a mixture having natural rubber and foaming agent to a kneading machine to kneading it repeatedly.

[0014] And then, send the mixture to a stirring machine via a conveying table to make the mixture well mix.

[0015] Next, send the well mixed mixture to a pressing machine to press the mixture into plank elements 2.

[0016] The fourth step of the present invention is that, please refer to FIG. 2, provide a cloth piece 1 at a side of the plank element 2, and then press the plank element 2 at the opposite side from the cloth piece 1 onto a fixture device 3 by hand to make the cloth piece 1 and the plank element 2 arched according to the shape of the fixture device 3.

[0017] Fifth, send the plank element 2 (with the fixture device 3) to a foaming machine and add predetermined dosages of sulfur to make the natural rubber reacting with the foaming agent such that the piece elements will foam and generating gas to secure cloth piece 3 on the plank element 2.

[0018] Sixth, remove the fixture device 3 from the foamed plank element 2, a wrist pad 10 is made at this time. The wrist pad 10 has a wrist bump 4 which is an arched portion on the wrist pad 10 formed by the fixture device 3.

[0019] Last, air cool the wrist pad 10 and cut it into predetermined shape.

[0020] The kneading machine, the stirring machine, pressing machine and the foaming machine described above are conventional equipments, so I will not describe their detail here.

[0021] Please refer to FIG. 3 and FIG. 4, the wrist pad 10 made from the method of the present invention has a flat portion 5 and the wrist bump 4 at a side of the flat portion 5. The wrist bump 4 has a Ω shape in the cross section thereof (which means the wrist bump 4 is hollow) so that the wrist bump 4 has a superior flexible capacity. When a user put his/her hand on the wrist pad 10 of the present invention, the wrist bump 4 will be deformed according to the wrist and fully support the wrist resting on it. The dimension of an opening under the wrist bump 4 is smaller than the dimension of the hollow space in the wrist bump 4 such that the wrist bump 4 will not be pressed into flat.

[0022] The advantages of the present invention are:

[0023] 1. The bottom of the wrist pad 10 of the present invention is natural rubber so that it dose not need to provide a rubber layer at the bottom side thereof to prevent it slip.

[0024] 2. When the natural rubber is foamed, there will be air generated in the foamed rubber and the air pressure will make the cloth piece fixedly attached on the foamed rubber. Such that no glue is added in the wrist pad of the present invention.

[0025] 3. The wrist pad of the present invention has a wrist bump thereon. The wrist bump is an arched portion of the wrist pad and it is molded with the wrist pad as a unit such that there is no need to provide a mold with a specific cavity

to mold the wrist bump therein. The shape of the wrist bump corresponds to the shape of the fixture device, so manufacturer can change different fixture devices to form the wrist bumps with different shapes.

[0026] 4. The wrist pad of the present invention is cut into specific shape after it is formed. So, it dose not need molds with different shape, the wrist pads of the present invention can be made into different shapes.

What is claimed is:

1. A method of manufacture a wrist pad, comprising the step of:

- a. kneading and stirring a mixture having natural rubber and foaming agent repeatedly to make it well mix;
- b. pressing said well mixed mixture into a plank element;
- c. forming an arched portion on said plank element;
- d. foaming said plank element with said arched portion so that chemical reaction will occur between said natural rubber and said foaming agent to produce an air pressure for forming said plank element to a wrist pad, and
- e. cooling said foamed wrist pad and cutting said wrist pad into a predetermined shape.

2. The method as defined in claim 1, wherein, in step c, said arched portion of said plank element is hollow therein.

3. The method as defined in claim 2, wherein further comprises a step of attaching a fixture device onto said plank

element and pressing said plank element to form said arched portion in step c.

4. The method as defined in claim 3, wherein presses said plank element is by hand work.

5. The method as defined in claim 1, wherein further comprises a step of attaching a cloth piece onto said plank element before said plank element being pressed in step c.

6. The method as defined in claim 1, wherein further comprises a step of removing said fixture device from said foamed wrist pad before step e.

7. The method as defined in claim 1, wherein said mixture is sent to a kneading machine to knead it first and then sends said mixture to a stirring machine to make it well mix in step a.

8. A wrist pad, comprising:

a flat portion composed of a rubber layer and a cloth layer, and

a wrist bump which is an arched portion on said flat portion and it is hollow therein.

9. The wrist pad as defined in claim 8, wherein said wrist bump has a Ω shape in cross section and said has an opening at bottom thereof.

10. The wrist pad as defined in claim 9, wherein the dimension of said opening under said wrist bump is smaller than the dimension of the hollow space in said wrist bump.

* * * * *