

(19) World Intellectual Property Organization  
International Bureau



(43) International Publication Date  
22 March 2001 (22.03.2001)

PCT

(10) International Publication Number  
WO 01/20714 A1

- (51) International Patent Classification<sup>7</sup>: H01Q 1/24, 1/38
- (21) International Application Number: PCT/IL00/00551
- (22) International Filing Date:  
8 September 2000 (08.09.2000)
- (25) Filing Language: English
- (26) Publication Language: English
- (30) Priority Data:  
60/153,179 10 September 1999 (10.09.1999) US
- (71) Applicant (for all designated States except US): GAL-TRONICS LTD. [IL/IL]; P.O. Box 1589, 14115 Tiberias (IL).
- (72) Inventors; and
- (75) Inventors/Applicants (for US only): READING, Leslie, J. [US/US]; 75-301 Ahola Kona, Kailua-Kona, HI 96740 (US). WINGO, Donald, E., T. [US/US]; 1230 Treadwell Bridge Road, Statham, GA 30666 (US).
- (74) Agents: DYM, Susie et al.; Sanford T. Colb & Co., P.O. Box 2273, 76122 Rehovot (IL).
- (81) Designated States (national): AE, AG, AL, AM, AT, AU, AZ, BA, BB, BG, BR, BY, BZ, CA, CH, CN, CR, CU, CZ, DE, DK, DM, DZ, EE, ES, FI, GB, GD, GE, GH, GM, HR, HU, ID, IL, IN, IS, JP, KE, KG, KP, KR, KZ, LC, LK, LR, LS, LT, LU, LV, MA, MD, MG, MK, MN, MW, MX, MZ, NO, NZ, PL, PT, RO, RU, SD, SE, SG, SI, SK, SL, TJ, TM, TR, TT, TZ, UA, UG, US, UZ, VN, YU, ZA, ZW.
- (84) Designated States (regional): ARIPO patent (GH, GM, KE, LS, MW, MZ, SD, SL, SZ, TZ, UG, ZW), Eurasian patent (AM, AZ, BY, KG, KZ, MD, RU, TJ, TM), European patent (AT, BE, CH, CY, DE, DK, ES, FI, FR, GB, GR, IE, IT, LU, MC, NL, PT, SE), OAPI patent (BF, BJ, CF, CG, CI, CM, GA, GN, GW, ML, MR, NE, SN, TD, TG).
- Published:**
- With international search report.
  - Before the expiration of the time limit for amending the claims and to be republished in the event of receipt of amendments.
- For two-letter codes and other abbreviations, refer to the "Guidance Notes on Codes and Abbreviations" appearing at the beginning of each regular issue of the PCT Gazette.

(54) Title: BROADBAND OR MULTI-BAND PLANAR ANTENNA

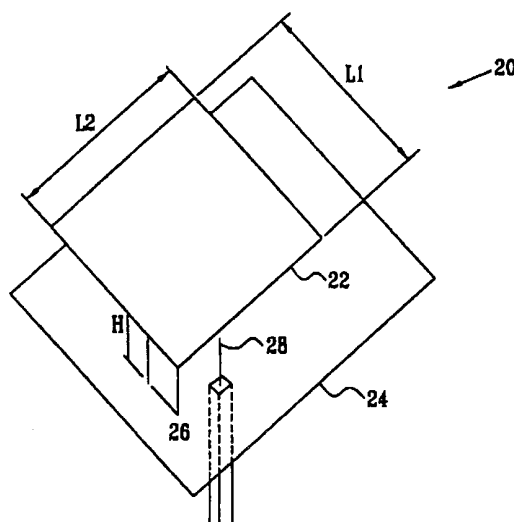

(57) Abstract: A planar antenna (30) includes first and second conductive plates (32, 40), which are disposed approximately parallel to one another and are electrically coupled one to the other, the first plate including first and second electrical elements (34, 36) separated by a slot (38) therebetween, the slot having first and second linear portions, such that the first linear portion is disposed between the first and second electrical elements, and the second linear portion is substantially perpendicular to and intersects with the first linear portion.



WO 01/20714 A1

BROADBAND OR MULTI-BAND PLANAR ANTENNA

## CROSS-REFERENCE TO RELATED APPLICATION

This application claims the benefit of U.S. Provisional Patent Application no. 60/153,179, filed  
5 September 10, 1999, which is incorporated herein by reference.

## FIELD OF THE INVENTION

The present invention relates generally to antennas, and specifically to compact, internal antennas for use in  
10 mobile communication devices.

## BACKGROUND OF THE INVENTION

Most mobile communication devices have external antennas, which are prone to breakage and are frequently a nuisance to users. As a result, there have been many  
15 attempts to develop antenna structures that can be incorporated inside the case of a device. For example, magnetic loop and helical antennas have been used inside paging devices and cordless telephones. Internal antennas of these types, however, cannot satisfy the  
20 performance requirements and size constraints of cellular telephones. Planar antennas, particularly of the "inverted-F" type, have been used in some cellular telephones, but only as an adjunct to a conventional external antenna.

25 Fig. 1 is a schematic, isometric drawing of an inverted-F antenna 20, as is known in the art. The antenna comprises a planar conductive element 22, which is coupled to a parallel ground plane 24 by a short-circuit plate 26. A transmission line 28 is fed  
30 through the ground plane to receive signals from the planar element. The dimensions of element 22, marked L1 and L2, must be one quarter wave at the design wavelength of the antenna. The small dimensions of element 22

relative to the design wavelength give the inverted-F antenna an inherently narrow bandwidth. The bandwidth of the antenna increases with the height H of element 22 above ground plane 24.

5 In order to fit antenna 20 inside a cellular telephone, operating in a range between 800 and 1000 MHz, it is necessary to use dielectric loading between element 22 and ground plane 24 so as to reduce the quarter wave dimensions. Dielectric loading, however, reduces the  
10 bandwidth of the antenna structure still further. The size constraints of the telephone case also limit the available height H. For use inside a cellular telephone, the dimensions of antenna 20 must be on the order of 35 x 25 x 7 mm, and the antenna must operate in a range  
15 between 800 and 1000 MHz, with a bandwidth of at least 80-100 MHz. These size and performance specifications cannot be achieved using the conventional design of Fig. 1.

#### SUMMARY OF THE INVENTION

20 It is an object of some aspects of the present invention to provide a broadband planar antenna.

It is an object of other aspects of the present invention to provide a multi-band planar antenna.

25 It is a further object of some aspects of the present invention to provide an improved planar antenna suitable for use inside a mobile communication device.

In preferred embodiments of the present invention, a slot is formed in the receiving plate of an inverted F antenna, thus dividing the plate into two or more  
30 electrical elements. Each of the elements defines a separate electrical path in the antenna, with its own resonant frequency. Preferably the resonant frequencies are closely spaced, so that the response curves of the elements overlap in order to provide a broad response  
35 band. Alternatively, the resonant frequencies are spaced

far apart, in order to provide multi-band response. The geometrical characteristics of slot and the two elements are designed to provide frequency and bandwidth characteristics that meet the requirements of cellular or other mobile communication systems, without exceeding size constraints of mobile communication devices.

There is therefore provided, in accordance with a preferred embodiment of the present invention, a planar antenna, including first and second conductive plates, which are disposed approximately parallel to one another and are electrically coupled one to the other, the first plate including first and second electrical elements separated by a slot therebetween, the slot having first and second linear portions, such that the first linear portion is disposed between the first and second electrical elements, and the second linear portion is substantially perpendicular to and intersects with the first linear portion.

Preferably, the antenna includes a conductive strap that electrically couples the first plate to the second plate, wherein the slot and strap are placed so as to define first and second electrical paths in the antenna, from the first and second electrical elements, respectively, to the strap.

Further preferably, the first and second electrical elements have respective, different first and second resonant frequencies. Most preferably, the first and second electric elements have respective first and second resonance bands around the respective resonant frequencies, and wherein the first and second resonant frequencies are mutually spaced so as to create a partial overlap between the first and second resonance bands, whereby the antenna functions as a broadband antenna. Alternatively, the first and second electric elements have respective first and second resonance bands around

the respective resonant frequencies, and wherein the first and second resonant frequencies are mutually spaced so that the first and second resonance bands are substantially non-overlapping, whereby the antenna  
5 functions as a multi-band antenna.

In a preferred embodiment, the antenna includes a capacitive element, which capacitively couples the first electrical element to the second electrical element.

In another preferred embodiment, one or more  
10 additional slots are formed in the first plate, in addition to the slot separating the first and second electrical elements.

There is also provided, in accordance with a preferred embodiment of the present invention, a method  
15 of forming a planar antenna, including:

providing a first conductive plate with a slot therein that separates the first plate into first and second electrical elements, the slot having first and second linear portions, such that the first linear  
20 portion is disposed between the first and second electrical elements, and the second linear portion is substantially perpendicular to and intersects with the first linear portion; and

positioning the first conductive plate approximately  
25 parallel to a second conductive plate so as to generate a resonant response to electromagnetic radiation at one or more desired frequencies.

The present invention will be more fully understood from the following detailed description of the preferred  
30 embodiments thereof, taken together with the drawings in which:

#### BRIEF DESCRIPTION OF THE DRAWINGS

Fig. 1 is a schematic, isometric drawing of a planar antenna, as is known in the art;

Fig. 2 is a schematic, isometric drawing of a broadband planar antenna, in accordance with a preferred embodiment of the present invention;

Fig. 3 is a plot showing a frequency response curve  
5 of the antenna of Fig. 2;

Fig. 4 is a schematic top view of the antenna of Fig. 2 with the addition of a dielectric coupling element, in accordance with a preferred embodiment of the present invention;

10 Fig. 5 is a schematic top view of a broadband planar antenna, in accordance with another preferred embodiment of the present invention; and

Fig. 6 is a schematic top view of a dual-band planar antenna, in accordance with a preferred embodiment of the  
15 present invention.

#### DETAILED DESCRIPTION OF PREFERRED EMBODIMENTS

Fig. 2 is a schematic, isometric drawing of a broadband planar antenna 30, in accordance with a preferred embodiment of the present invention. Antenna  
20 30 comprises a top (receiving) plate 32 and an approximately parallel bottom (ground) plate 40, separated by a non-conductive medium. The two plates are connected together at a single point by a conductive strap 42. The transmission line feed-through to plate  
25 32, as shown in Fig. 1, is omitted from this and subsequent figures for the sake of simplicity. Preferably, in order to reduce the resonant frequency of the antenna relative to its dimensions, the medium between the plates comprises a dielectric material, such  
30 as Delrin (not shown in the figures).

The bandwidth of antenna 30 is increased, relative to the conventional design of Fig. 1, by introducing a T-shaped slot 38 in plate 32, so as to create a multiple resonance condition. Slot 38 divides plate 32 into two  
35 electrical elements 34 and 36, having different

electrical path lengths to strap 42. Each of elements 34 and 36 therefore has its own, different resonant frequency. Preferably, slot 38 is designed so that the two resonant frequencies are closely spaced, with the resonant bands overlapping in order to create a broad resonant response. The center placement of strap 42, which is the basic radiating element, ensures that the resonant lengths are closely spaced. In addition, the lengths of elements 34 and 36 can be trimmed to further aid in achieving the desired frequencies and overlap condition. Slot 38 also serves to lower the resonant frequency of the antenna.

Fig. 3 is a plot that schematically illustrates the frequency response of antenna 30. This plot was generated using plates 32 and 40 with dimensions 35 x 25 mm, with an overall height between the plates of 5 mm. As shown in the figure, the antenna has a center frequency of 965.6 MHz and a bandwidth (at -10 dB) of 90.2 MHz. The dual, overlapping response curves of elements 34 and 36 can be seen in the "W" shape of the plot in Fig. 3. Similar results were obtained at other frequencies in the 800-1000 MHz range by varying the dimensions and spacing of plates 32 and 40. These dimensions and specific frequency data are given here by way of example, and the principles of the present invention may be applied to produce antennas of other dimensions, for use in other frequency ranges.

The width of slot 38 serves as a coupling mechanism between the two resonant structures of elements 34 and 36. This coupling controls the depth of resonance of the response curves, as well as the spacing between the resonant points. The width of the slot controls the amount of coupling, and therefore care must be exercised in establishing the slot width. An under-coupled condition will cause the two resonant points to be widely

spaced in frequency, whereas over-coupling will cause the dual-resonant shape of the response to be lost entirely.

Fig. 4 is a schematic top view of antenna 30, wherein a capacitive coupling element 44 is placed across slot 38, in accordance with a preferred embodiment of the present invention. Only top plate 32 is seen in this view. In experimental use, coupling element 44 was made from a single-sided printed circuit board positioned over slot 38, with no electrical contact between the coupling element and the antenna. The amount of coupling is controlled by the size of the element and its position along the slot. Preferably, in actual production, coupling element 44 is contained within a layer of plastic either above or below the slot. Alternatively, electrical elements 34 and 36 are coupled by a discrete capacitor instead of element 44.

Fig. 5 is a schematic top view of another broadband, planar antenna 50, in accordance with a preferred embodiment of the present invention. As in antenna 30, an upper plate 52 of antenna 50 is divided into electrical elements 56 and 58 by a "T" slot 60. (Here, too, the lower plate is not shown.) Two additional slots 62 and 64 are added to further lower the frequency of the antenna by increasing the path lengths through elements 56 and 58 to strap 42. Thus, the overall size of the antenna, relative to the design frequency, is reduced.

Alternatively, other geometries may be used to achieve an overlapping double resonance, in addition to the embodiments of Figs. 2, 4 and 5. For example, the top and bottom plates need not be square or rectangular as shown in the figures. In addition, the ground plane (bottom plate 40) does not have to be the same size as the top plate. The top plate may also be folded to increase electrical length without sacrificing broadband performance. Other geometrical shapes and configurations



of the antenna plates and of the slot or slots formed in the top plate will be apparent to those skilled in the art and are considered to be within the scope of the present invention. It will be appreciated that the terms  
5 "top" and "bottom" are used herein for convenience in identifying the antenna plates, which may in actual practice be placed in substantially any orientation.

Although the antennas described above are single-band structures, in alternative embodiments of the present invention, slotted, planar antennas are designed  
10 for multi-band operation. For example, the structure of antenna 30 (Fig. 2) may be modified so that the resonant frequencies of conducting elements 34 and 36 are widely spaced and substantially decoupled.

Fig. 6 is a schematic top view of a dual-band antenna 70, in accordance with a preferred embodiment of the present invention. In place of the "T" slot of the preceding embodiments, a cross-slot 78 is formed in a top  
15 plate 72 of the antenna. (The bottom plate is not shown.) The cross-slot presents more than two electrical paths to strap 42, so that multiple resonances are created. This design was found to give dual-band performance while maintaining a broad bandwidth at the lower frequency. Such a design can be used to produce a  
20 single structure that covers two or more non-harmonic related frequency bands, such as the GSM (950 MHz) and DCS (1.8 GHz) bands.

In an alternative embodiment of the present invention, not shown in the figures, two independent  
30 planar antennas, having different frequency bands, are mounted on the same dielectric spacer. The antennas are preferably of the slotted-T type shown in Fig. 2, so that each antenna has a broadband response at its respective frequency. It has been found that the coupling between  
35 the antennas is low. Two feeds are required in this

configuration, as opposed to the single feed used in the cross-slot design, but bandwidths in excess of 100 MHz at 900 MHz and 300 MHz at 1700 MHz have been observed.

5 Although preferred embodiments are described herein with specific reference to cellular telephones and cellular communication bands, the principles of the present invention are also applicable to antennas for use in other areas of wireless communications. It will thus be appreciated that the preferred embodiments described  
10 above are cited by way of example, and that the present invention is not limited to what has been particularly shown and described hereinabove. Rather, the scope of the present invention includes both combinations and subcombinations of the various features described  
15 hereinabove, as well as variations and modifications thereof which would occur to persons skilled in the art upon reading the foregoing description and which are not disclosed in the prior art.

## CLAIMS

1. A planar antenna, comprising first and second conductive plates, which are disposed approximately parallel to one another and are electrically coupled one to the other, the first plate comprising first and second electrical elements separated by a slot therebetween, the slot having first and second linear portions, such that the first linear portion is disposed between the first and second electrical elements, and the second linear portion is substantially perpendicular to and intersects with the first linear portion.
2. An antenna according to claim 1, and comprising a conductive strap that electrically couples the first plate to the second plate.
3. An antenna according to claim 2, wherein the slot and strap are placed so as to define first and second electrical paths in the antenna, from the first and second electrical elements, respectively, to the strap.
4. An antenna according to claim 1, wherein the first and second electrical elements have respective, different first and second resonant frequencies.
5. An antenna according to claim 4, wherein the first and second electric elements have respective first and second resonance bands around the respective resonant frequencies, and wherein the first and second resonant frequencies are mutually spaced so as to create a partial overlap between the first and second resonance bands, whereby the antenna functions as a broadband antenna.
6. An antenna according to claim 4, wherein the first and second electric elements have respective first and second resonance bands around the respective resonant frequencies, and wherein the first and second resonant frequencies are mutually spaced so that the first and

second resonance bands are substantially non-overlapping, whereby the antenna functions as a multi-band antenna.

7. An antenna according to claim 1, and comprising a capacitive element, which capacitively couples the first  
5 electrical element to the second electrical element.

8. An antenna according to claim 1, wherein one or more additional slots are formed in the first plate, in addition to the slot separating the first and second electrical elements.

10 9. A method of forming a planar antenna, comprising:  
providing a first conductive plate with a slot therein that separates the first plate into first and second electrical elements, the slot having first and second linear portions, such that the first linear  
15 portion is disposed between the first and second electrical elements, and the second linear portion is substantially perpendicular to and intersects with the first linear portion; and

20 positioning the first conductive plate approximately parallel to a second conductive plate so as to generate a resonant response to electromagnetic radiation at one or more desired frequencies.

10. A method according to claim 9, wherein positioning the first conductive plate comprises electrically  
25 coupling the first plate to the second plate at a selected location on the first plate.

11. A method according to claim 10, wherein providing the first conductive plate comprises disposing the slot therein so as to define first and second electrical paths  
30 in the antenna, from the first and second electrical elements, respectively, to the selected location.

12. A method according to claim 9, wherein providing the first conductive plate comprises providing the first and

second electrical elements with respective, different first and second resonant frequencies.

- 5 13. A method according to claim 12, wherein the first and second electric elements have respective first and second resonance bands around the respective resonant frequencies, and wherein the first and second resonant frequencies are mutually spaced so as to create a partial overlap between the first and second resonance bands, whereby the antenna functions as a broadband antenna.
- 10 14. A method according to claim 12, wherein the first and second electric elements have respective first and second resonance bands around the respective resonant frequencies, and wherein the first and second resonant frequencies are mutually spaced so that the first and second resonance bands are substantially non-overlapping, whereby the antenna functions as a multi-band antenna.
- 15 15. A method according to claim 9, and comprising capacitively coupling the first electrical element to the second electrical element.

FIG. 1

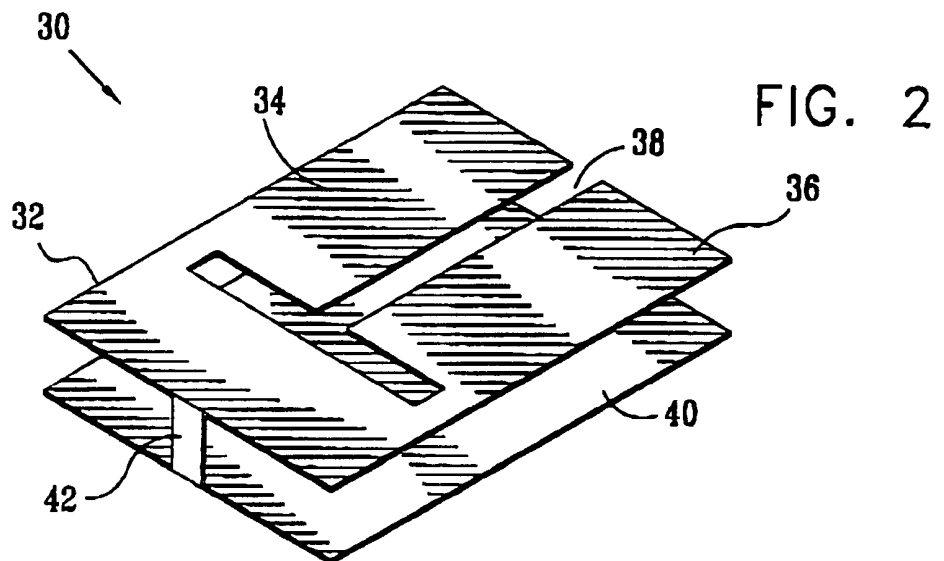
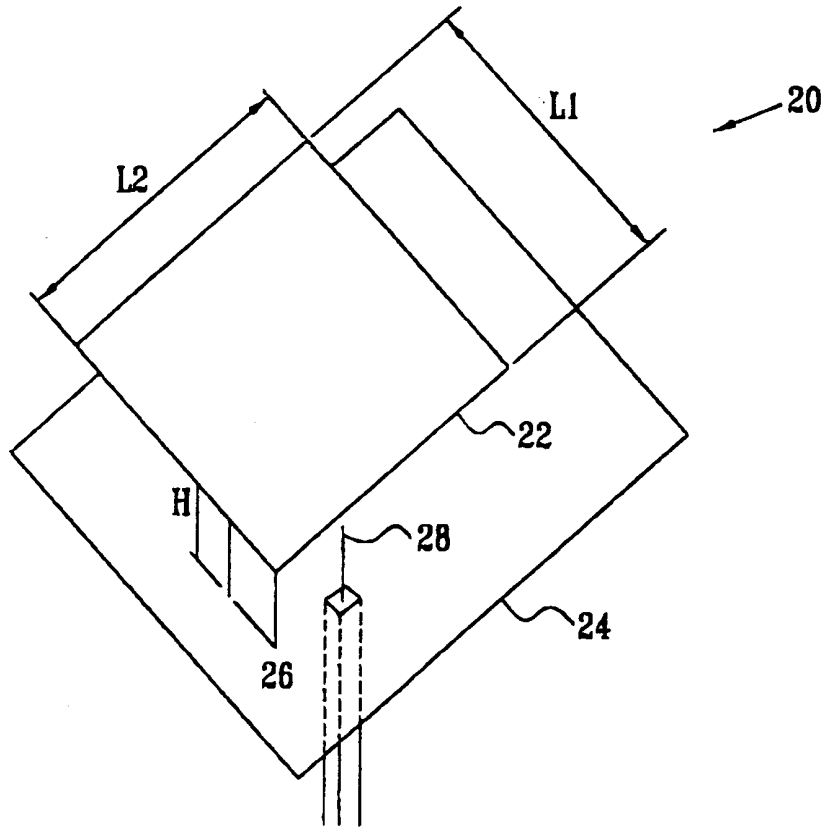

FIG. 3

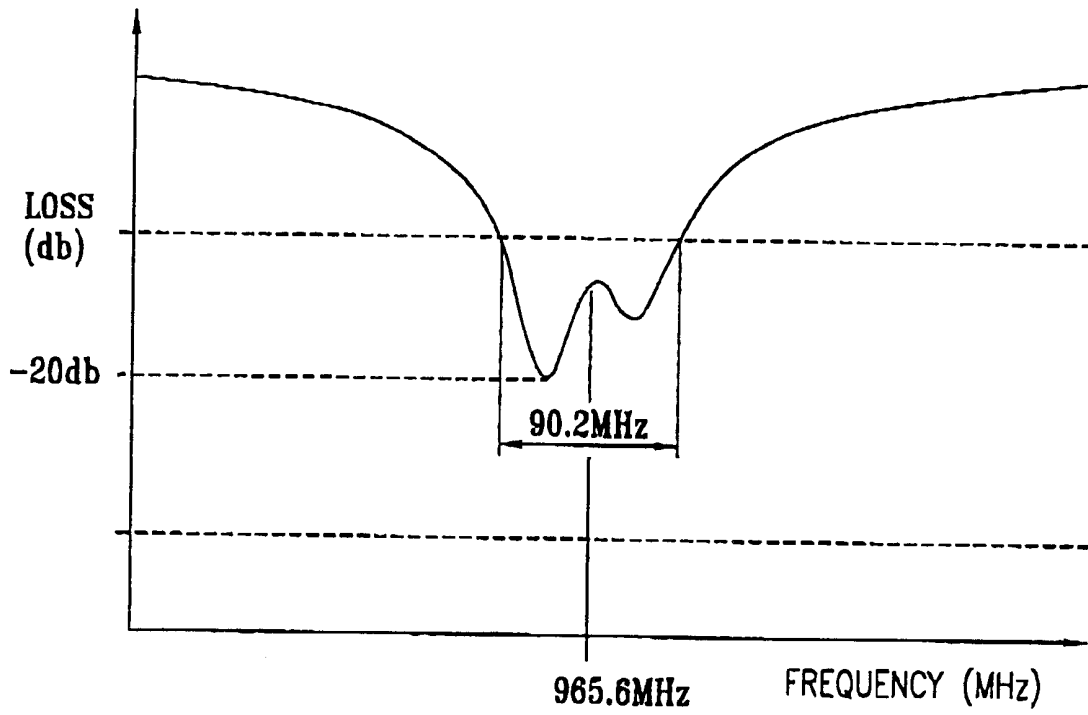

FIG. 4

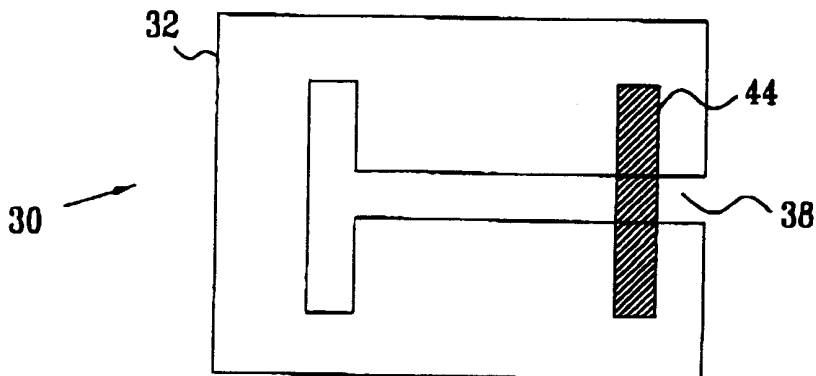
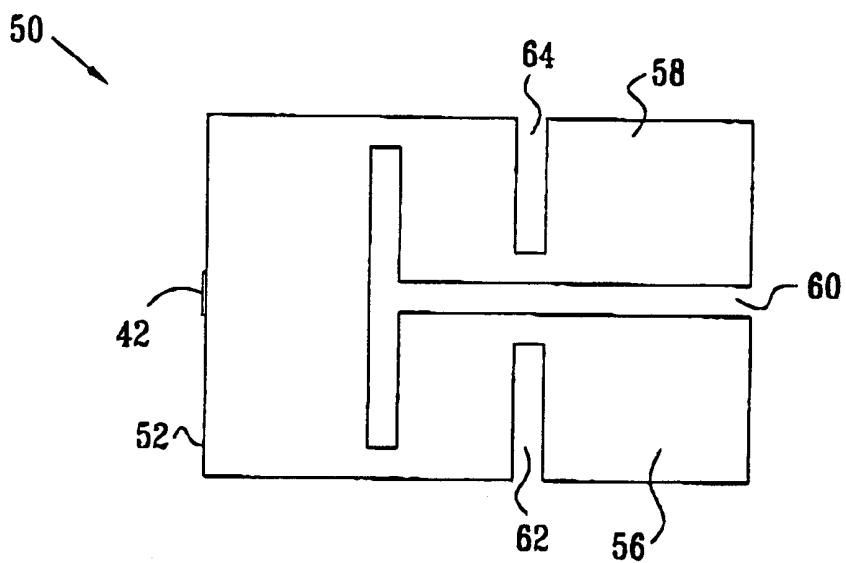
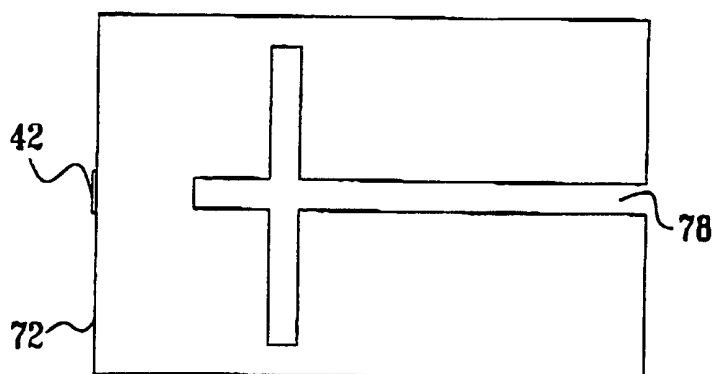

FIG. 5



70

FIG. 6





INTERNATIONAL SEARCH REPORT

International application No.  
PCT/IL00/00551

**A. CLASSIFICATION OF SUBJECT MATTER**

IPC(7) :H01Q 1/24, 1/38

US CL :343/702, 718, 767; 343/700MS, 841, 846, 848

According to International Patent Classification (IPC) or to both national classification and IPC

**B. FIELDS SEARCHED**

Minimum documentation searched (classification system followed by classification symbols)

U.S. : 343/702, 718, 767; 343/700MS, 841, 846, 848

Documentation searched other than minimum documentation to the extent that such documents are included in the fields searched

Electronic data base consulted during the international search (name of data base and, where practicable, search terms used)

**C. DOCUMENTS CONSIDERED TO BE RELEVANT**

Category*	Citation of document, with indication, where appropriate, of the relevant passages	Relevant to claim No.
X, P	US 5,940,041 A (KOYAMA et al) 17 August 1999 (17.08.1999), entire document.	1, 9
X	US 5,898,404 A (JOU) 27 April 1999 (27.04.1999), entire document.	1-15

Further documents are listed in the continuation of Box C.  See patent family annex.

* Special categories of cited documents:	"T" later document published after the international filing date or priority date and not in conflict with the application but cited to understand the principle or theory underlying the invention
"A" document defining the general state of the art which is not considered to be of particular relevance	"X" document of particular relevance; the claimed invention cannot be considered novel or cannot be considered to involve an inventive step when the document is taken alone
"E" earlier document published on or after the international filing date	"Y" document of particular relevance; the claimed invention cannot be considered to involve an inventive step when the document is combined with one or more other such documents, such combination being obvious to a person skilled in the art
"L" document which may throw doubts on priority claim(s) or which is cited to establish the publication date of another citation or other special reason (as specified)	"&" document member of the same patent family
"O" document referring to an oral disclosure, use, exhibition or other means	
"P" document published prior to the international filing date but later than the priority date claimed	

Date of the actual completion of the international search

01 DECEMBER 2000

Date of mailing of the international search report

JAN 19 2001

Name and mailing address of the ISA/US  
Commissioner of Patents and Trademarks  
Box PCT  
Washington, D.C. 20231

Facsimile No. (703) 305-3230

Authorized officer

USPTO CHUC TRAN

Telephone No. (703) 306-5984