

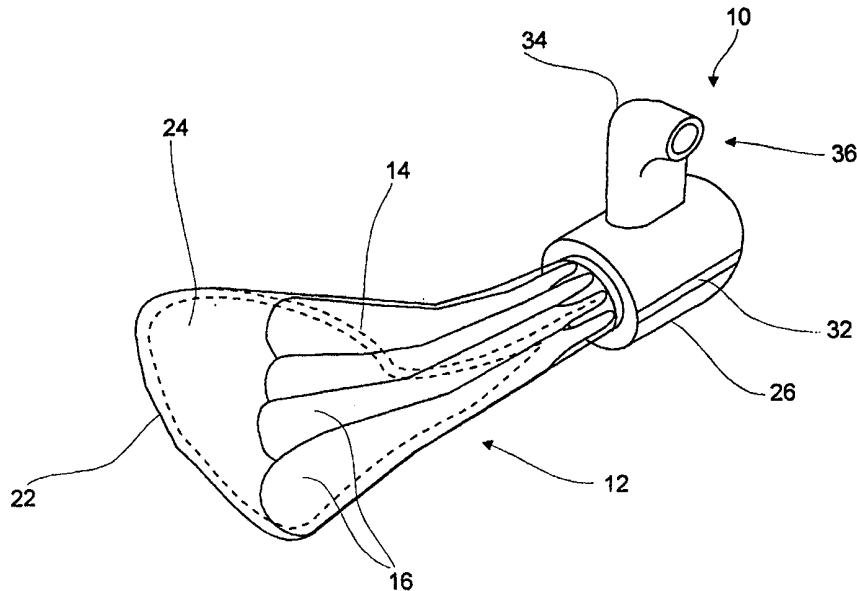

INTERNATIONAL APPLICATION PUBLISHED UNDER THE PATENT COOPERATION TREATY (PCT)

| | | |
|--|------------------|--|
| <p>(51) International Patent Classification ⁶ : A61B 17/00, A61F 2/04</p> | <p>A1</p> | <p>(11) International Publication Number: WO 00/01306 (43) International Publication Date: 13 January 2000 (13.01.00)</p> |
| <p>(21) International Application Number: PCT/IL98/00318 (22) International Filing Date: 7 July 1998 (07.07.98) (71) Applicant (for all designated States except US): PULSECARE LTD. [IL/IL]; Naiot Technology Center, P.O. Box 732, 17106 Nazareth Illit (IL). (72) Inventors; and (75) Inventors/Applicants (for US only): SCHER, Menachem [IL/IL]; Zahal Street 9A, 30900 Zichron Yaakov (IL). KRITZMAN, Amnon [IL/IL]; Zahal Street 9B, 30900 Zichron Yaakov (IL). (74) Agent: FRIEDMAN, Mark, M.; Beit Samueloff, Haomanim Street 7, 67897 Tel Aviv (IL).</p> | | <p>(81) Designated States: AL, AM, AT, AU, AZ, BA, BB, BG, BR, BY, CA, CH, CN, CU, CZ, DE, DK, EE, ES, FI, GB, GE, GH, GM, GW, HR, HU, ID, IL, IS, JP, KE, KG, KP, KR, KZ, LC, LK, LR, LS, LT, LU, LV, MD, MG, MK, MN, MW, MX, NO, NZ, PL, PT, RO, RU, SD, SE, SG, SI, SK, SL, TJ, TM, TR, TT, UA, UG, US, UZ, VN, YU, ZW, ARIPO patent (GH, GM, KE, LS, MW, SD, SZ, UG, ZW), Eurasian patent (AM, AZ, BY, KG, KZ, MD, RU, TJ, TM), European patent (AT, BE, CH, CY, DE, DK, ES, FI, FR, GB, GR, IE, IT, LU, MC, NL, PT, SE), OAPI patent (BF, BJ, CF, CG, CI, CM, GA, GN, ML, MR, NE, SN, TD, TG). Published With international search report.</p> |

(54) Title: MINIMAL INVASIVE CARDIAC MASSAGE DEVICE



(57) Abstract

A cardiac massage device (10) deployable by a minimal invasive procedure for applying pulsatory pressure to a ventricular wall of a heart includes an inflatable receptacle (12) deployable between a closed insertion state and an open state. The open state of the device is configured for substantially enveloping the ventricular portion of the heart. A plurality of support elements (14) are mechanically linked to the inflatable receptacle so as to deploy the inflatable receptacle to its open state. Preferably, the support elements are implemented as flexible rods resiliently biased to return to a pre-defined shape and a retaining mechanism (22) is provided. Also described is a deployment technique employing suction clamping and a two-stage trocar (40, 42).

FOR THE PURPOSES OF INFORMATION ONLY

Codes used to identify States party to the PCT on the front pages of pamphlets publishing international applications under the PCT.

| | | | | | | | |
|----|--------------------------|----|--|----|--|----|--------------------------|
| AL | Albania | ES | Spain | LS | Lesotho | SI | Slovenia |
| AM | Armenia | FI | Finland | LT | Lithuania | SK | Slovakia |
| AT | Austria | FR | France | LU | Luxembourg | SN | Senegal |
| AU | Australia | GA | Gabon | LV | Latvia | SZ | Swaziland |
| AZ | Azerbaijan | GB | United Kingdom | MC | Monaco | TD | Chad |
| BA | Bosnia and Herzegovina | GE | Georgia | MD | Republic of Moldova | TG | Togo |
| BB | Barbados | GH | Ghana | MG | Madagascar | TJ | Tajikistan |
| BE | Belgium | GN | Guinea | MK | The former Yugoslav Republic of Macedonia | TM | Turkmenistan |
| BF | Burkina Faso | GR | Greece | ML | Mali | TR | Turkey |
| BG | Bulgaria | HU | Hungary | MN | Mongolia | TT | Trinidad and Tobago |
| BJ | Benin | IE | Ireland | MR | Mauritania | UA | Ukraine |
| BR | Brazil | IL | Israel | MW | Malawi | UG | Uganda |
| BY | Belarus | IS | Iceland | MX | Mexico | US | United States of America |
| CA | Canada | IT | Italy | NE | Niger | UZ | Uzbekistan |
| CF | Central African Republic | JP | Japan | NL | Netherlands | VN | Viet Nam |
| CG | Congo | KE | Kenya | NO | Norway | YU | Yugoslavia |
| CH | Switzerland | KG | Kyrgyzstan | NZ | New Zealand | ZW | Zimbabwe |
| CI | Côte d'Ivoire | KP | Democratic People's Republic of Korea | PL | Poland | | |
| CM | Cameroon | KR | Republic of Korea | PT | Portugal | | |
| CN | China | KZ | Kazakstan | RO | Romania | | |
| CU | Cuba | LC | Saint Lucia | RU | Russian Federation | | |
| CZ | Czech Republic | LI | Liechtenstein | SD | Sudan | | |
| DE | Germany | LK | Sri Lanka | SE | Sweden | | |
| DK | Denmark | LR | Liberia | SG | Singapore | | |
| EE | Estonia | | | | | | |

Minimal Invasive Cardiac Massage Device

FIELD AND BACKGROUND OF THE INVENTION

The present invention relates to devices for cardiac treatment, and more particularly to a device for cardiac massage which can be positioned by a minimal
5 invasive procedure.

Various devices are known for cardiac massage. Examples are disclosed in U.S. Patents Nos. 4,536,893 to Parravicini and 5,713,954 to Rosenberg et al. These describe inflatable cup-shaped devices which are deployed around the heart. A pulsating supply of fluid to the devices generates inward pressure on the
10 ventricular portion of the heart, thereby assisting the pumping action.

These devices are both designed for implantation during an open heart surgery procedure. As a result, their use is limited to long term applications in which the patient is in a sufficiently fit general state of health to be able to withstand such a procedure. Furthermore, such implantable devices do not allow
15 sufficiently rapid deployment to be useful in cases for which cardiac assist must be started very rapidly or for emergency applications such as Cardio-Pulmonary Resuscitation (CPR) procedures where direct cardiac massage could be much more effective than the conventional procedure of pressing on the rib cage.

A further shortcoming of the existing cardiac massage devices relates to the
20 manner of retaining the devices in position around the heart. It is important that the device applies pressure only to the ventricular region of the heart. However, when pressure is applied from a device surrounding only the lower part of the heart

corresponding to the ventricular region, the shape and texture of the heart tends to make it slip out of the device. To counter this tendency, the device of Parravicini provides straps for wrapping around the root of the aorta and pulmonary artery. This somewhat primitive fastening technique is, however, clearly limited to open surgical procedures and may exert pressure on the aorta or atria.

There is therefore a need for a device for cardiac massage which may be deployed rapidly in a minimal invasive procedure and which provides effective retention of the device in position around the heart.

SUMMARY OF THE INVENTION

The present invention is a device for cardiac massage which can be positioned by a minimal invasive procedure.

According to the teachings of the present invention there is provided, a cardiac massage device deployable by a minimal invasive procedure for applying pulsatory pressure to a ventricular wall of a heart, the device comprising: (a) an inflatable receptacle deployable between a closed insertion state and an open state, the open state being configured for substantially enveloping the ventricular portion of the heart; and (b) a plurality of support elements mechanically linked to the inflatable receptacle so as to deploy the inflatable receptacle to the open state.

According to a further feature of the present invention, the support elements are implemented as flexible rods resiliently biased to return to a pre-defined shape.

According to a further feature of the present invention, there is also provided an elongated hollow structure for storage and deployment of the device,

the inflatable receptacle and the flexible rods being retractable within the elongated hollow structure so as to confine the flexible rods to an initial state corresponding to the closed insertion state of the inflatable receptacle, the flexible rods returning to the pre-defined shape as they advance out from the elongated hollow structure.

5 According to a further feature of the present invention, the elongated hollow structure forms a storage stage of a two-stage trocar, an insertion stage of the trocar being configured for insertion through the skin of a patient as part of a minimal invasive surgical procedure.

 According to a further feature of the present invention, the insertion stage of
10 the trocar includes a curved hollow guide portion for insertion within the patient, the curved hollow guide portion providing a turn angle of between about 15° and about 30°.

 According to a further feature of the present invention, there is also provided a manually operable mechanism for displacing the inflatable receptacle
15 and the flexible rods along a length of the trocar.

 According to a further feature of the present invention, there is also provided a retaining mechanism associated with the inflatable receptacle and configured for deploying around a supraventricular portion of the heart so as to retain the inflatable receptacle in a position enveloping the ventricular portion of
20 the heart.

 According to a further feature of the present invention, the retaining mechanism includes at least one drawstring mechanism.

According to a further feature of the present invention, the at least one drawstring mechanism is connected to the inflatable receptacle via a non-inflatable web.

According to an alternative feature of the present invention, the retaining
5 mechanism includes at least one inflatable retaining element, the inflatable retaining element and the inflatable receptacle being provided with independent fluid supply conduits.

According to a further feature of the present invention, there is also provided a retractable suction clamping system including: (a) a suction cup
10 deployed for suction clamping to the apex of the heart; and (b) an axially displaceable tube forming a fluid connection with the suction cup, such that, when the tube is displaced forward and suction is applied to the tube, the suction cup clamps to the heart and, when the suction is released and the tube is displaced rearwards, the suction cup is withdrawn from contact with the heart.

15 According to a further feature of the present invention, there is also provided at least one electrode deployed on an inner surface of the inflatable receptacle so as to contact the heart when the device is deployed.

There is also provided according to the teachings of the present invention, a cardiac massage device deployable by a minimal invasive procedure for applying
20 pulsatory pressure to a ventricular wall of a heart, the device comprising: (a) an inflatable receptacle for substantially enveloping the ventricular portion of the heart, the inflatable receptacle being configured to exert pulsating pressure against the ventricular wall in response to a pulsating fluid supply; and (b) a retaining

mechanism associated with the inflatable receptacle and configured for deploying around a supraventricular portion of the heart so as to retain the inflatable receptacle in a position substantially enveloping the ventricular portion of the heart.

5 According to a further feature of the present invention, the retaining mechanism includes at least one drawstring mechanism.

 According to a further feature of the present invention, the at least one drawstring mechanism is connected to the inflatable receptacle via a non-inflatable web.

10 According to an alternative feature of the present invention, the retaining mechanism includes at least one inflatable retaining element, the inflatable retaining element and the inflatable receptacle being provided with independent fluid supply conduits.

 There is also provided according to the teachings of the present invention, a
15 method of minimal invasive deployment of a cardiac massage device around the ventricular portion of the heart of a patient, the method comprising the steps of:
(a) introducing the device in a compact state through the pericardium in the region near the diaphragm; and (b) opening the device to form a receptacle which substantially envelopes the ventricular portion of the heart.

20 According to a further feature of the present invention, the opening of the device occurs through a plurality of resiliently biased flexible rods deployed within the device returning to a pre-defined shape.

According to a further feature of the present invention, suction clamping is also applied to the surface of the heart during deployment of the device, the suction clamping being removed once the device is properly deployed.

According to a further feature of the present invention, a retaining
5 mechanism is deployed around a supraventricular portion of the heart so as to retain the receptacle in a position enveloping the ventricular portion of the heart.

According to a further feature of the present invention, the compact state exhibits a maximum diameter of no more than about 4 cm and preferably between about 1.5 and about 2.5 cm.

10 BRIEF DESCRIPTION OF THE DRAWINGS

The invention is herein described, by way of example only, with reference to the accompanying drawings, wherein:

FIG. 1 is a schematic isometric view of a device for cardiac massage, constructed and operative according to the teachings of the present invention, ready
15 to be deployed;

FIG. 2 is a schematic isometric view of the device of Figure 1 in a deployed state;

FIG. 3 is a schematic cross-sectional view through the deployed device of Figure 2;

20 FIG. 4 is a schematic cross-sectional view through a base connector of the device of Figure 2;

FIG. 5 is a schematic isometric view of the device of Figure 2 engaged around a heart;

FIG. 6 is a schematic isometric view of a two-stage trocar for use in deploying the device of Figure 1;

5 FIG. 7 is a longitudinal cross-sectional view through the trocar of Figure 6 with the device of Figure 1 stored therein;

FIG. 8 is a schematic isometric view of the first stage of the trocar of Figure 6 with the device of Figure 1 in its deployed state;

10 FIGS. 9A-9D are schematic side views showing a sequence of stages during blind deployment of the device of Figure 1 around a heart;

FIG. 10 is a schematic rear view of a first implementation of a retaining mechanism for the device of Figure 1 employing a drawstring mechanism; and

15 FIG. 11 is a schematic isometric view of a second implementation of a retaining mechanism for the device of Figure 1 employing an inflatable retaining element.

DESCRIPTION OF THE PREFERRED EMBODIMENTS

The present invention is a device for cardiac massage which can be positioned by a minimal invasive procedure.

20 The principles and operation of a device according to the present invention may be better understood with reference to the drawings and the accompanying description.

Referring now to the drawings, Figures 1-5 show a cardiac massage device, generally designated **10**, constructed and operative according to the teachings of the present invention, which is deployable by a minimal invasive procedure. Device **10** is used to apply pulsatory pressure to a ventricular wall of a heart.

5 Generally speaking, cardiac massage device **10** includes an inflatable receptacle **12** deployable between a closed insertion state (Figure 1) and an open state (Figure 2), the open state being configured for substantially enveloping the ventricular portion of the heart in a manner shown in Figure 5. A number of support elements **14** are mechanically linked to inflatable receptacle **12** so as to
10 deploy the inflatable receptacle to its open state. Support elements **14** are preferably implemented as flexible rods resiliently biased to return to a pre-defined shape. These rods serve both to push forward the inflatable receptacle during introduction of the device into a patient and to open it into a correctly positioned and shaped configuration to substantially envelope the ventricular portion of the
15 heart within the pericardium.

In a preferred implementation, the configuration of rods **14** is chosen to provide unguided deployment around the heart in a manner to be described below. This allows “blind” insertion of the device by a minimal invasive procedure. The term “blind” is used in this context to refer to a minimal invasive procedure
20 performed without simultaneous use of imaging techniques for positioning. The minimal invasive nature of the deployment makes the use of the device practical even with patients not sufficiently fit to undergo major surgery and minimizes the trauma to the patient. The possibility of blind insertion renders the device rapidly

deployable so that it can be used when cardiac assist must be rapidly begun or in emergency procedures such as CPR.

It should be appreciated that the device of the present invention may be used in a wide range of circumstances where cardiac assist is required. The device generally serves a “bridge to recovery” or “bridge to surgery” role for periods which may range from a matter of minutes or hours up to weeks or even several months.

In keeping with the normal definitions of “minimal invasive” procedures, the insertion state of device **10** preferably exhibits a maximum diameter of no more than about 4 cm, and typically between about 1.5 and about 2.5 cm. This ensures minimum possible trauma to the patient as a result of the procedure.

Turning now to the features of device **10** in more detail, inflatable receptacle **12** includes at least one, and typically 4-8, inflatable chambers **16** extending along the length of receptacle **12**. A preferred arrangement of these chambers may be seen in Figure 3. The inner wall **18** of each chamber is elastically stretchable while the outer wall **20** is relatively non-stretchable. These properties may be achieved either by employing different materials for the inner and outer walls or by making outer wall **20** relatively thick compared to inner wall **18**. In either case, the materials may readily be selected from a range of polymer materials conventionally used for surgical devices. The result of these properties is that, when chambers **16** are inflated, the primary effect is directed inward so as to exert pressure on a part of the heart located within inflatable receptacle **12**.

It should be noted that chambers **16** may be commonly or independently controlled. By way of example, in certain applications, assistance may be desired exclusively, or primarily, for the left ventricle to prevent excess pressure to the lungs. For such applications, a left/right subdivision of the fluid supply to
5 chambers **16** is required.

As already mentioned, support elements **14** are preferably implemented as flexible rods which exhibit a “memory” for a predefined shape. Usually, at least three rods, and typically between 4 and 8, are used to achieve the desired opening action. The rods may be of metal or polymer material, or a combination thereof,
10 and may have any cross-sectional shape.

A number of possibilities exist for the positioning of rods **14**. They may be included within either inner wall **18** or outer wall **20**, or may form part of the interconnection between adjacent chambers **16** as shown here. A further possibility is positioning of rods **14** within the volume contained by chambers **16**. In all of
15 these cases, especially where rods **14** are made from metal, they are preferably surrounded by a layer of polymer material to avoid direct contact between the rods and body tissue.

A further feature of certain preferred embodiments of device **10** is the provision of a retractable suction clamping system **44**. Suction clamping system **44**
20 is used to clamp device **10** temporarily in position relative to the heart during deployment, then being released and retracted away from the heart once correct positioning of receptacle **12** around the heart has been achieved. As may best be seen by referring ahead to Figure 7, suction clamping system **44** includes a suction

cup **46** mounted on the end of a tube **48** positioned axially within device **10** in its storage state. Tube **48** is provided with both a suction connection and a mechanical connection for displacing suction clamping system **44** axially. The operation of suction clamping system **44** will be described below with reference to Figures 9A-
5 9D.

It is a particular feature of most preferred implementations of the present invention that device **10** features a retaining mechanism **22** operable during a minimal invasive procedure to retain inflatable receptacle **12** in a position enveloping the ventricular portion of the heart. Retaining mechanism **22** is
10 configured to be deployed around a supraventricular portion of the heart, i.e., a portion of the heart lying above the ventricular portion, where the reduced diameter of the heart allows secure retention as shown in Figure 5. At the same time, as mentioned above, it is important that inflatable receptacle **12** does not exert pressure on the atria. To this end, retaining mechanism **22** is preferably
15 mechanically linked to inflatable receptacle **12** via a non-inflatable web **24**. The word "web" is used herein to refer to any continuous or discontinuous flexible layer which forms a mechanical link between retaining mechanism **22** and inflatable receptacle **12**. Typically, web **24** is implemented as a single layer continuation of the outer walls of chambers **16**. Details of two possible
20 implementations of retaining mechanism **22** will be described below with reference to Figures 10 and 11.

Insertion and subsequent control of device **10** is controlled through a base connector **26**. Base connector **26** houses fluid supply conduits **28**, as seen in Figure

4, which connect to the root of each inflatable chamber 16. These conduits preferably have relatively large areas to minimize resistance for a pulsating fluid supply. Base connector 26 additionally provides a mechanical connection to rods 14 and houses retaining mechanism connections 30.

5 Externally, base connector 26 preferably also has guide features such as guide slots 32 for guiding the base connector in a straight path within a trocar tube to be described below, and a projecting handle 34 which allows manual displacement of device 10 along the trocar and provides one or more external fluid connection port 36 as well as a retaining mechanism control 38.

10 Deployment of device 10 is preferably performed as a minimal invasive procedure by use of a trocar. A preferred trocar design and other details of the deployment procedure will now be described with reference to Figures 6-9.

Turning first to Figures 6 and 7, there is shown a two stage trocar made up of an insertion stage 40 for insertion through a small incision and a storage stage 15 42. Second stage 42 has a substantially cylindrical form within which device 10 may be retracted, thereby confining device 10 to an initial closed insertion state as shown in Figure 1. Handle 34 of base connector 26 projects through a longitudinal slot 44 in second stage 42 to provide a manually operable slide for displacing device 10 along the length of the trocar. At the same time, handle 34 provides 20 accessible connections for the various fluid, suction and mechanical connections employed to deploy and operate device 10. Storage stage 42 is preferably attached to insertion stage 40 through a clip-on connection 50 so as to be removable after deployment and replaceable for withdrawal of the device.

Insertion stage **40** preferably includes a curved hollow guide portion **52** for insertion within the patient. Guide portion **52** is preferably formed with a turn angle of between about 15° and about 30°, and typically about 20°. In other words, guide portion **52** redirects device **10** during deployment by an angle of about 20°
5 from the extensional direction of storage stage **42**. This provides the correct alignment for deployment of the device curving under the sternum to an initial position facing the apex of the heart. A shield **54** is preferably deployed around insertion stage **40**. This serves to delimit the fully inserted position of the trocar, as well as providing a seal around the incision.

10 Figure 8 shows the deployed state of the device within insertion stage **40** after removal of storage stage **52**. In this state, the part of the device projecting from the body is small and can be secured by various techniques such as one or more belt around the patient.

The procedure for deploying device **10** will now be described with reference
15 to Figures 9A-9D. Initially, insertion stage **40** is introduced through an incision in the outer wall of the abdomen just below the sternum **55** and through a corresponding incision through the lower part of the pericardium **56** in the region near the diaphragm. At this stage, tube **48** is displaced forward and has suction applied so that suction cup **46** clamps to the heart **58** at or near its apex. This
20 clamping effect maintains the spatial relation between the insertion stage **40** of the trocar and the heart during the rest of the deployment procedure.

Then, handle **34** is gently eased forward along slot **44**, thereby advancing device **10** out through guide portion **52**. As support elements **14** emerge, their

resilient memory urges them to their predefined diverging form, thereby opening inflatable receptacle **12** to its open form. The simultaneous advancing and opening action brings the device through the stages shown in Figures 9B and 9C until it substantially envelopes the ventricular portion of the heart. At the same time, the
5 distal part of retaining mechanism **22** and its associated non-inflatable web **24** extend over part of the superventricular portion of the heart, primarily on the dorsal side which is not obstructed by blood vessels.

Once the device reaches its fully deployed state, retaining mechanism **22** is tightened around the superventricular portion as shown in Figure 9D. This is
10 sufficient to firmly retain the heart within inflatable receptacle **12** without unduly restricting the normal movement of the heart. The suction clamping is then released and tube **48** withdrawn so that suction cup **46** has no effect on the subsequent operation of the device.

It will be clear that removal of the device is achieved by a simple reversal of
15 the steps described, except that the suction clamping feature is superfluous during removal. The resilient nature of support elements **14** provides an inherent self-opening feature which facilitates opening of retaining mechanism **22**.

Turning now briefly to Figure 10, this shows a first preferred implementation of retaining mechanism **22**. In this case, the tightening action is
20 achieved by a drawstring mechanism in which a draw-string or wire **60** extends along a pair of sleeves **62** which extend up to near the opening of receptacle **12**. In this case retaining mechanism control **38** may be implemented as a simple manual

or automated drawstring connection which pulls on the wire 60, thereby shortening the circumference of the opening between the ends of sleeves 62.

An alternative implementation of retaining mechanism 22 is shown in Figure 11. Here an inflatable collar 64 may be inflated through an independent fluid supply conduit 66 to lodge against the supraventricular portion of the heart.

Turning now briefly to the operation of deployed device 10, the device is driven by a pulsed source of fluid, typically in the form of a pulsatile pump. In an implementation for very short term emergency use, a manual hand pump may be used. The operating fluid may be liquid, gas or a mixture thereof, and is preferably sterile.

Timing of the pulses is preferably performed according to one of three modes. Firstly, in a CPR case where unaided heart activity has stopped, pulses are generated either manually or according to suitable pulse timing circuitry of any kind. Secondly, where either a natural or induced heart beat is detectable, the pulses are preferably synchronized with the heart, either through an electrocardiogram (ECG) signal or by direct synchronization with a pacemaker or defibrillator. Details of how to achieve ECG synchronization may be found in a number of sources such as the aforementioned U.S. Patent No. 5,713,954 to Rosenberg et al. which is hereby incorporated by reference in its entirety. In a third mode, the basic synchronization with an ECG signal is enhanced by closed loop feedback. Suitable sources for feedback to provide a measure of the effectiveness of the cardiac assist include, but are not limited to, measurements of the cardiac output, the ejection fraction, or the systolic blood pressure. These quantities may

be measured by any conventional techniques. Clearly, to implement these various modes, suitable hardware or hardware/software combinations are provided. These typically include a microprocessor unit operating appropriate software under a suitable operating system as is well known in the art.

5 Finally, it should be appreciated that the device of the present invention may be used to advantage in conjunction with a range of other devices and techniques. Examples include, but are not limited to, use in combination with a pacemaker, defibrillator, ventilator systems or CPR systems. For such applications, one or more electrodes 70 may be incorporated into the inner surface for inflatable
10 receptacle as shown schematically in Figure 3.

It will be appreciated that the above descriptions are intended only to serve as examples, and that many other embodiments are possible within the spirit and the scope of the present invention.

WHAT IS CLAIMED IS:

1. A cardiac massage device deployable by a minimal invasive procedure for applying pulsatory pressure to a ventricular wall of a heart, the device comprising:

- (a) an inflatable receptacle deployable between a closed insertion state and an open state, said open state being configured for substantially enveloping the ventricular portion of the heart; and
- (b) a plurality of support elements mechanically linked to said inflatable receptacle so as to deploy said inflatable receptacle to said open state.

2. The device of claim 1, wherein said support elements are implemented as flexible rods resiliently biased to return to a pre-defined shape.

3. The device of claim 2, further comprising an elongated hollow structure for storage and deployment of the device, said inflatable receptacle and said flexible rods being retractable within said elongated hollow structure so as to confine said flexible rods to an initial state corresponding to said closed insertion state of said inflatable receptacle, said flexible rods returning to said pre-defined shape as they advance out from said elongated hollow structure.

4. The device of claim 3, wherein said elongated hollow structure forms a storage stage of a two-stage trocar, an insertion stage of said trocar being

configured for insertion through the skin of a patient as part of a minimal invasive surgical procedure.

5. The device of claim 4, wherein said insertion stage of said trocar includes a curved hollow guide portion for insertion within the patient, said curved hollow guide portion providing a turn angle of between about 15° and about 30°.

6. The device of claim 3, further comprising a manually operable mechanism for displacing said inflatable receptacle and said flexible rods along a length of said trocar.

7. The device of claim 1, further comprising a retaining mechanism associated with said inflatable receptacle and configured for deploying around a supraventricular portion of the heart so as to retain said inflatable receptacle in a position enveloping the ventricular portion of the heart.

8. The device of claim 7, wherein said retaining mechanism includes at least one drawstring mechanism.

9. The device of claim 8, wherein said at least one drawstring mechanism is connected to said inflatable receptacle via a non-inflatable web.

10. The device of claim 7, wherein said retaining mechanism includes at least one inflatable retaining element, said inflatable retaining element and said inflatable receptacle being provided with independent fluid supply conduits.

11. The device of claim 1, further comprising a retractable suction clamping system including:

- (a) a suction cup deployed for suction clamping to the apex of the heart;
and
- (b) an axially displaceable tube forming a fluid connection with said suction cup,

such that, when said tube is displaced forward and suction is applied to said tube, said suction cup clamps to the heart and, when the suction is released and said tube is displaced rearwards, said suction cup is withdrawn from contact with the heart.

12. The device of claim 1, further comprising at least one electrode deployed on an inner surface of said inflatable receptacle so as to contact the heart when the device is deployed.

13. A cardiac massage device deployable by a minimal invasive procedure for applying pulsatory pressure to a ventricular wall of a heart, the device comprising:

- (a) an inflatable receptacle for substantially enveloping the ventricular portion of the heart, said inflatable receptacle being configured to

exert pulsating pressure against the ventricular wall in response to a pulsating fluid supply; and

- (b) a retaining mechanism associated with said inflatable receptacle and configured for deploying around a supraventricular portion of the heart so as to retain said inflatable receptacle in a position substantially enveloping the ventricular portion of the heart.

14. The device of claim 13, wherein said retaining mechanism includes at least one drawstring mechanism.

15. The device of claim 14, wherein said at least one drawstring mechanism is connected to said inflatable receptacle via a non-inflatable web.

16. The device of claim 13, wherein said retaining mechanism includes at least one inflatable retaining element, said inflatable retaining element and said inflatable receptacle being provided with independent fluid supply conduits.

17. A method of minimal invasive deployment of a cardiac massage device around the ventricular portion of the heart of a patient, the method comprising the steps of:

- (a) introducing the device in a compact state through the pericardium in the region near the diaphragm; and
- (b) opening the device to form a receptacle which substantially envelopes the ventricular portion of the heart.

18. The method of claim 17, wherein said opening of the device occurs through a plurality of resiliently biased flexible rods deployed within the device returning to a pre-defined shape.

19. The method of claim 17, further comprising application of suction clamping to the surface of the heart during deployment of the device, and removal of the suction clamping once the device is properly deployed.

20. The method of claim 17, further comprising deploying a retaining mechanism around a supraventricular portion of the heart so as to retain said receptacle in a position enveloping the ventricular portion of the heart.

21. The method of claim 17, wherein said compact state exhibits a maximum diameter of no more than about 4 cm.

22. The method of claim 17, wherein said compact state exhibits a maximum diameter of between about 1.5 and about 2.5 cm.

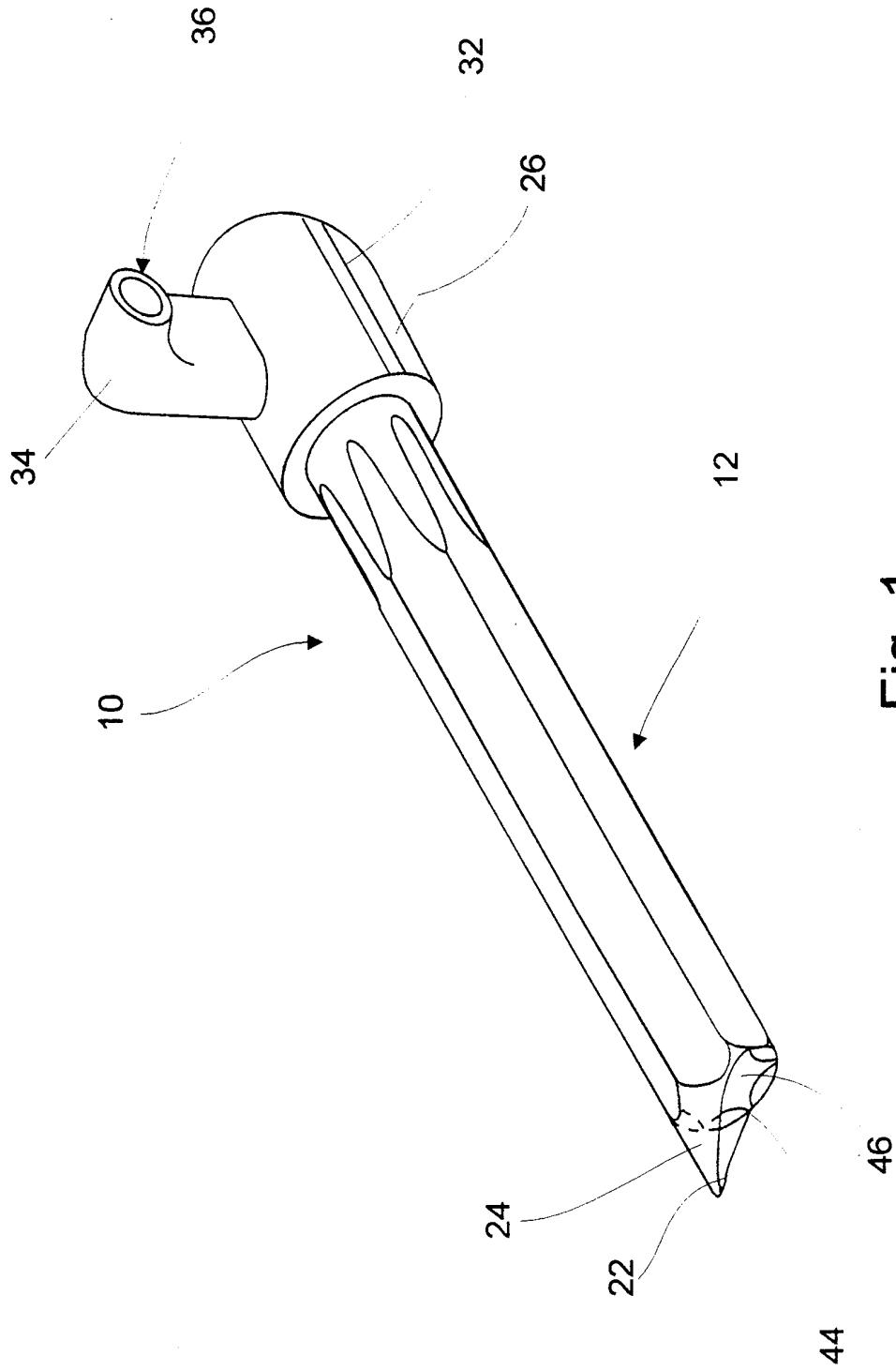

Fig. 1

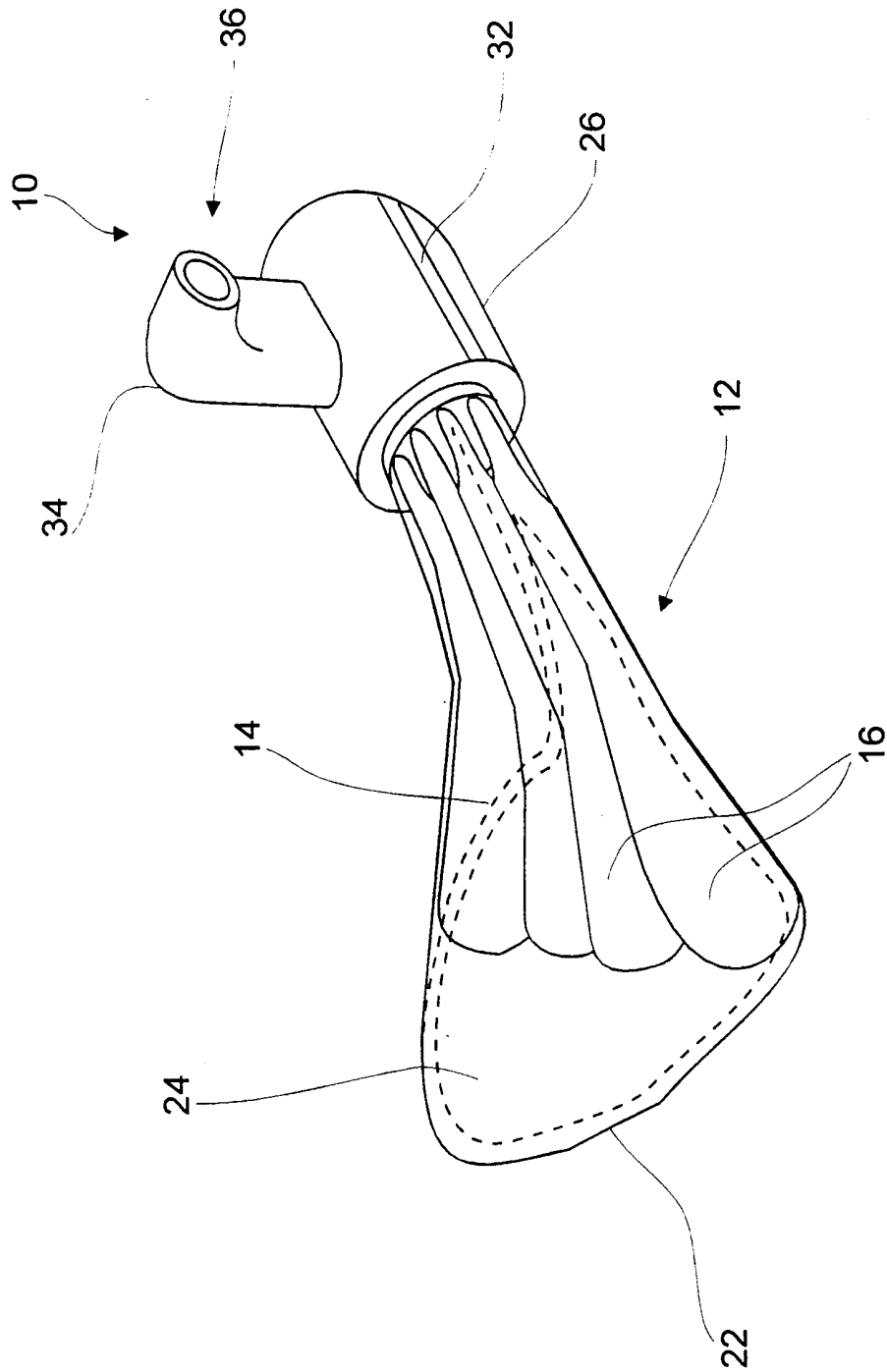

Fig. 2

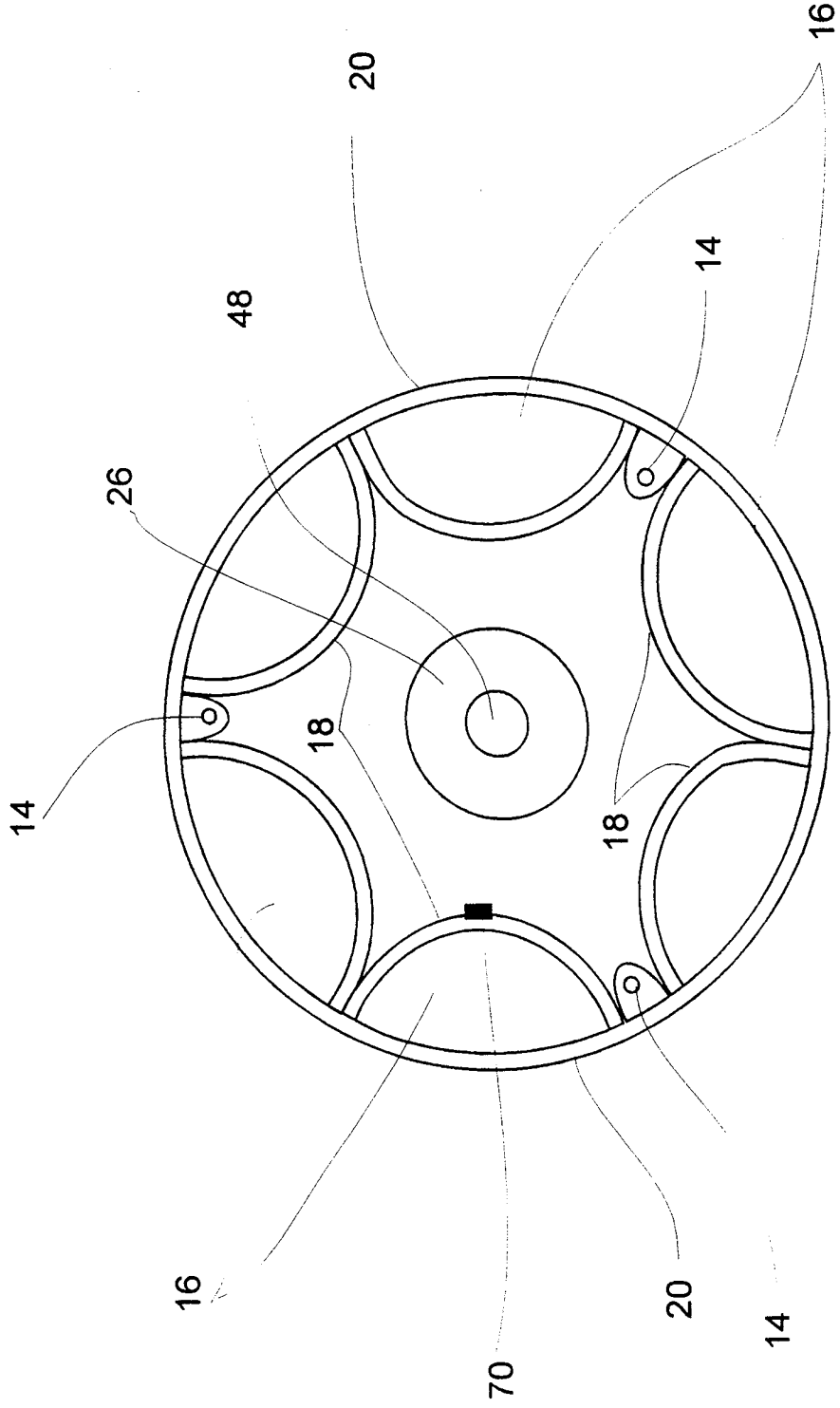

Fig. 3

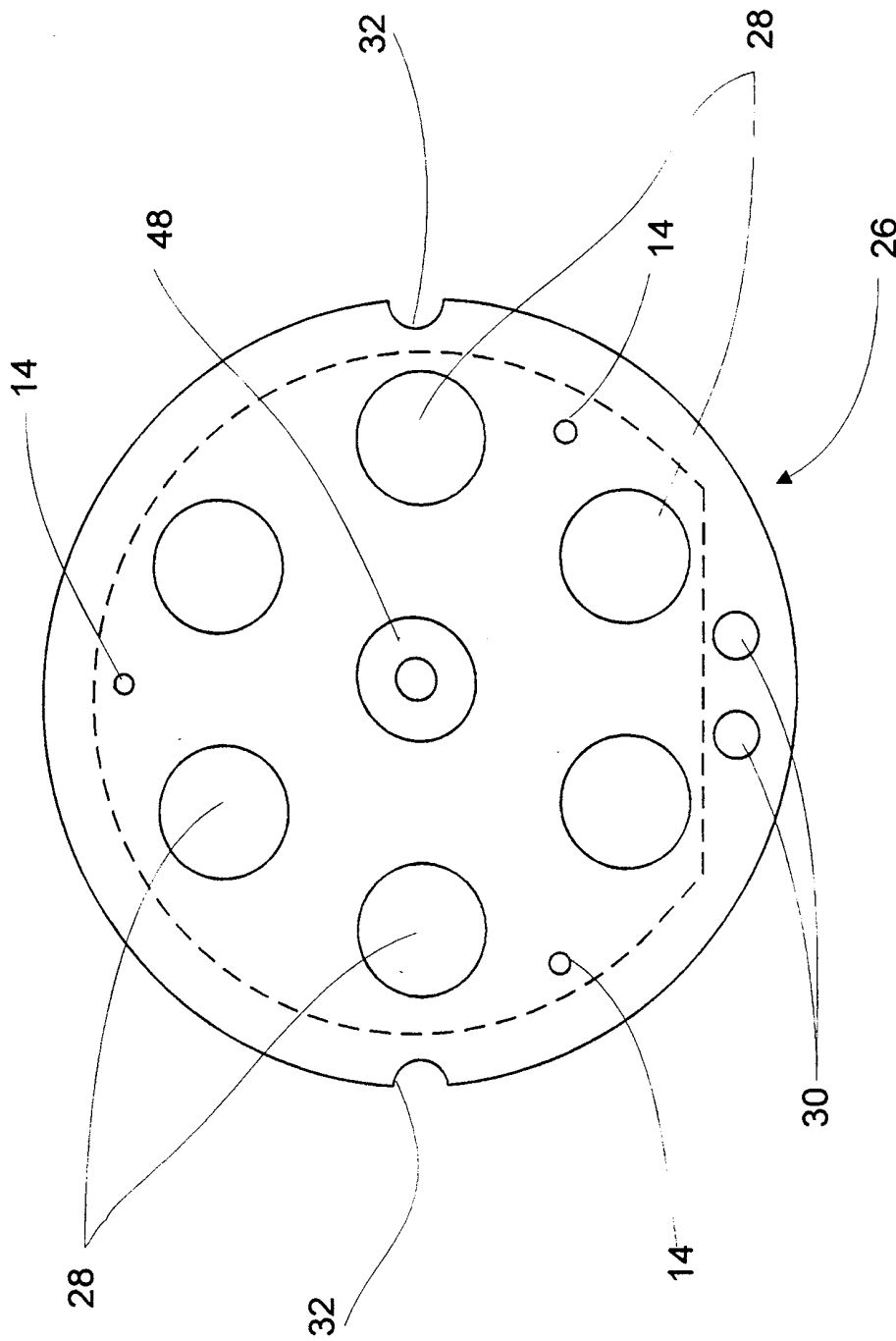

Fig. 4

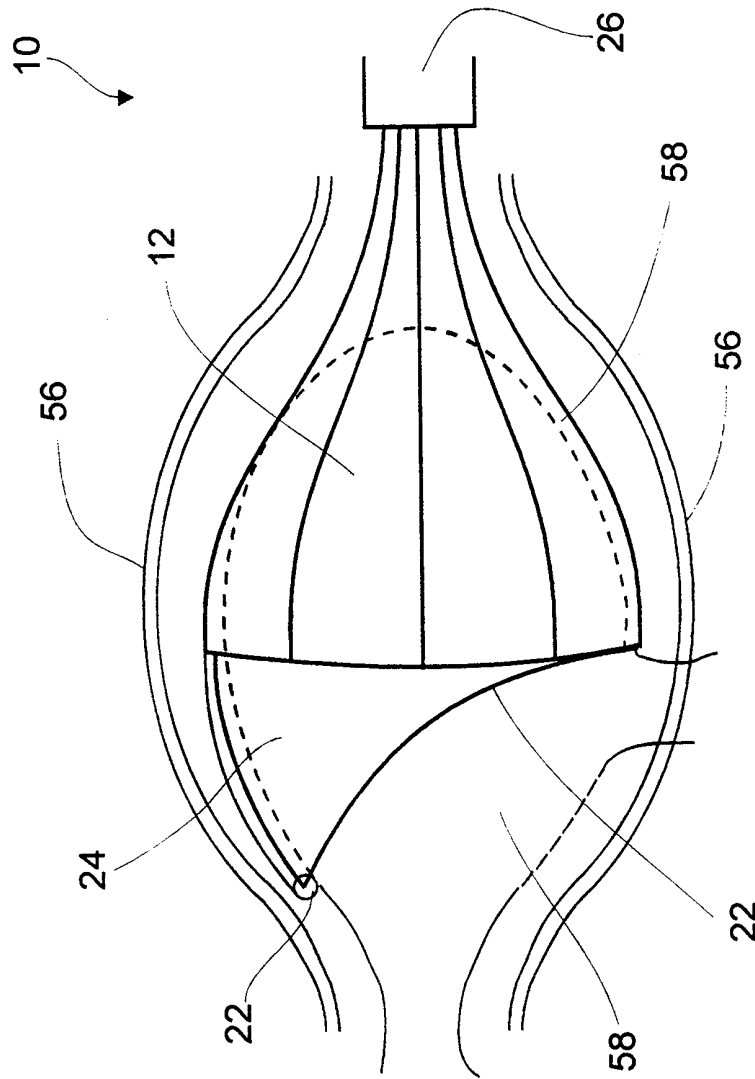

Fig. 5

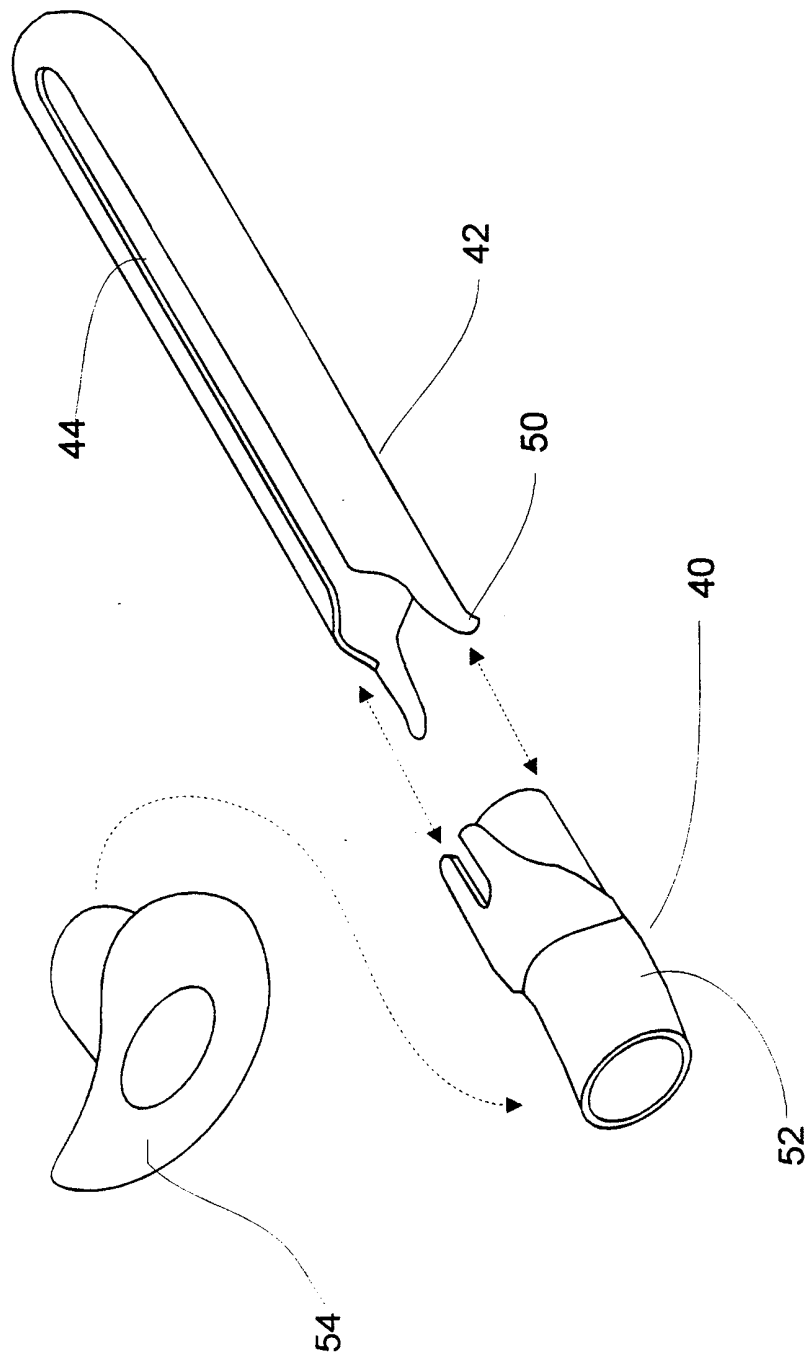

Fig. 6

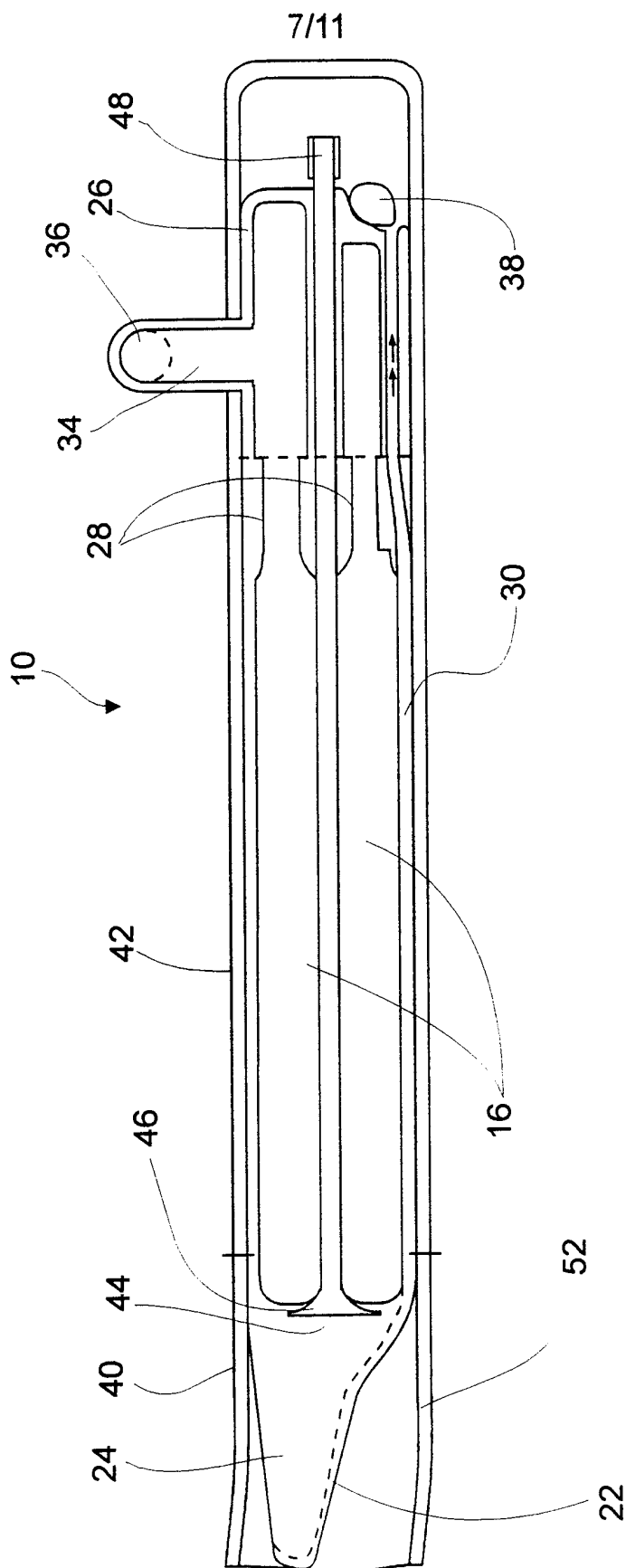

Fig. 7

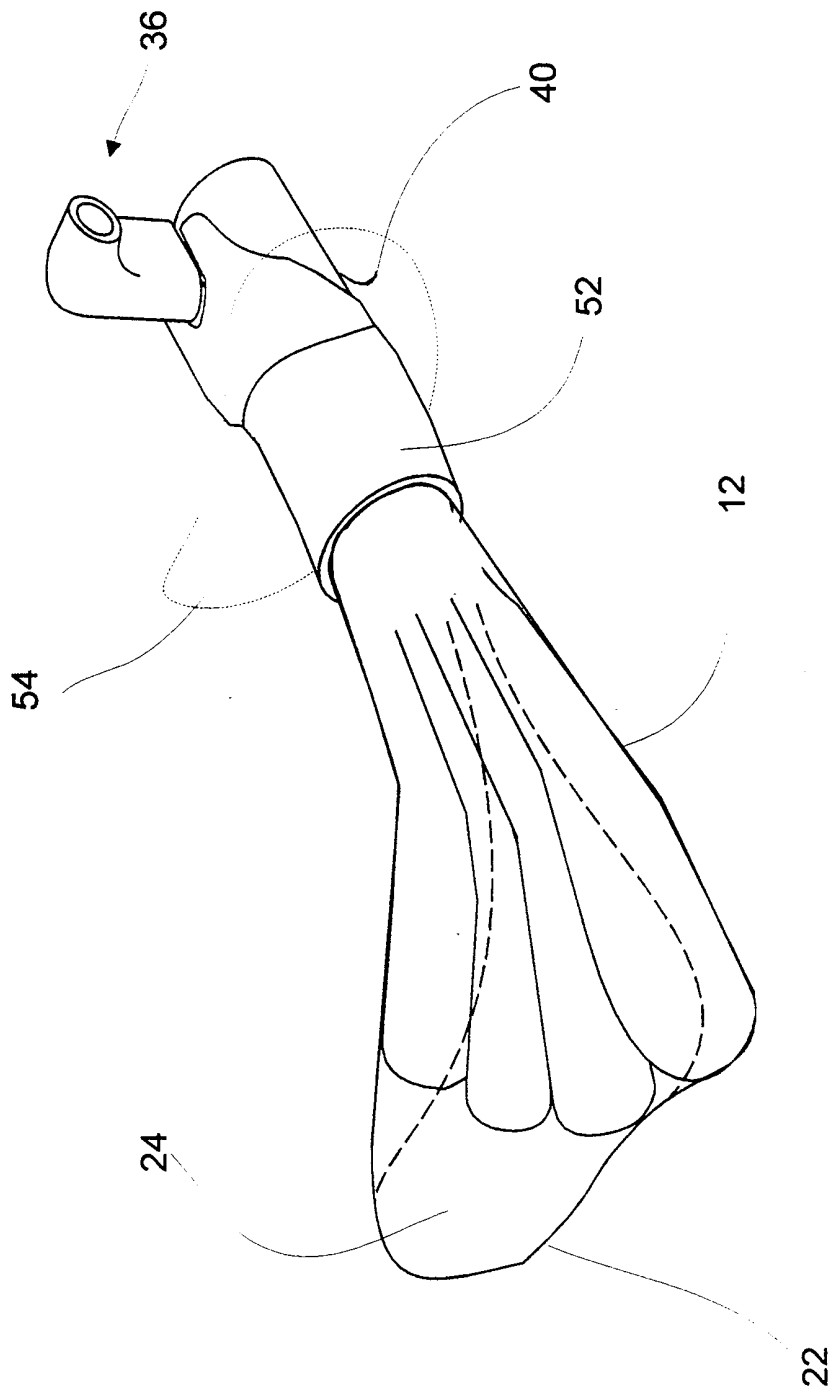

Fig. 8

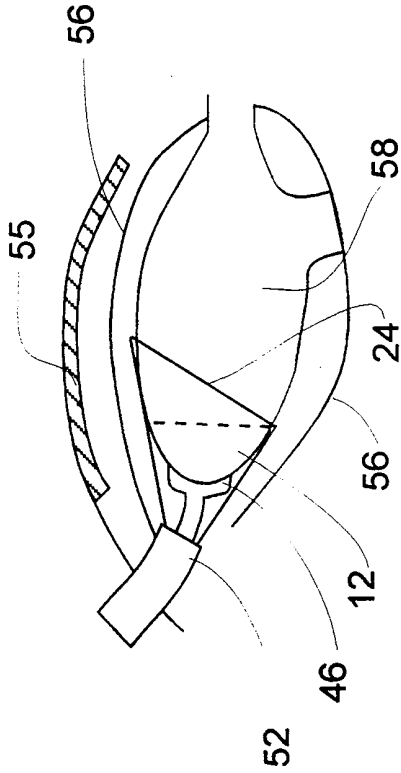

Fig. 9b

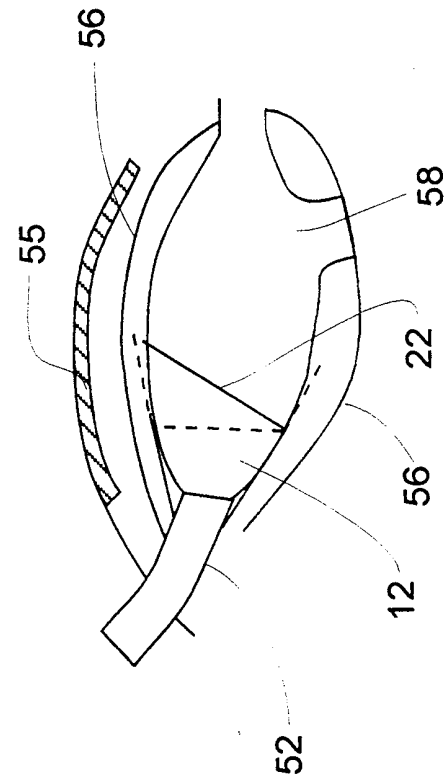

Fig. 9d

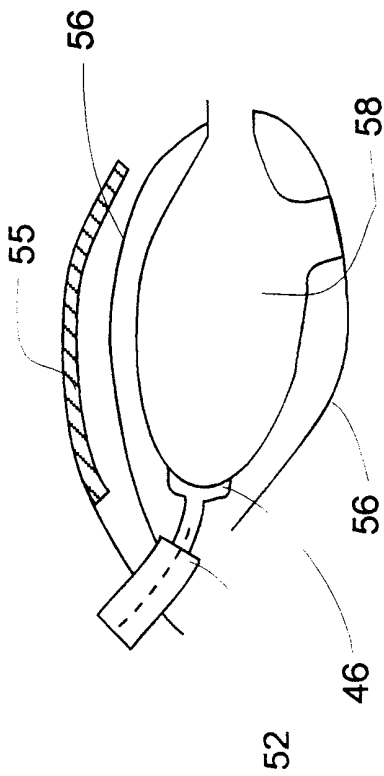

Fig. 9a

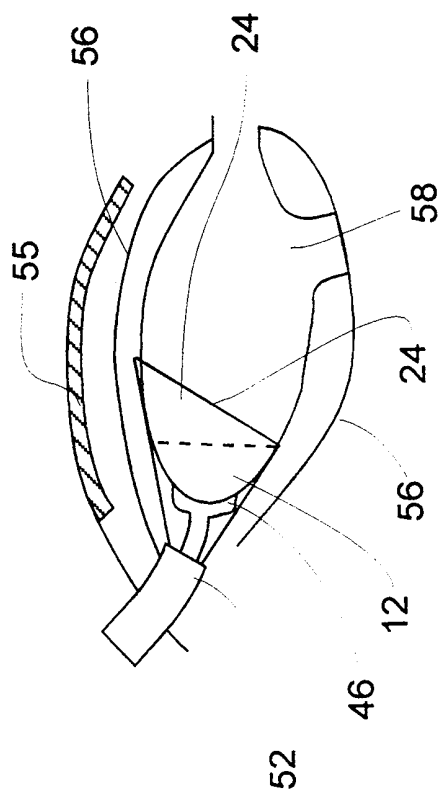

Fig. 9c

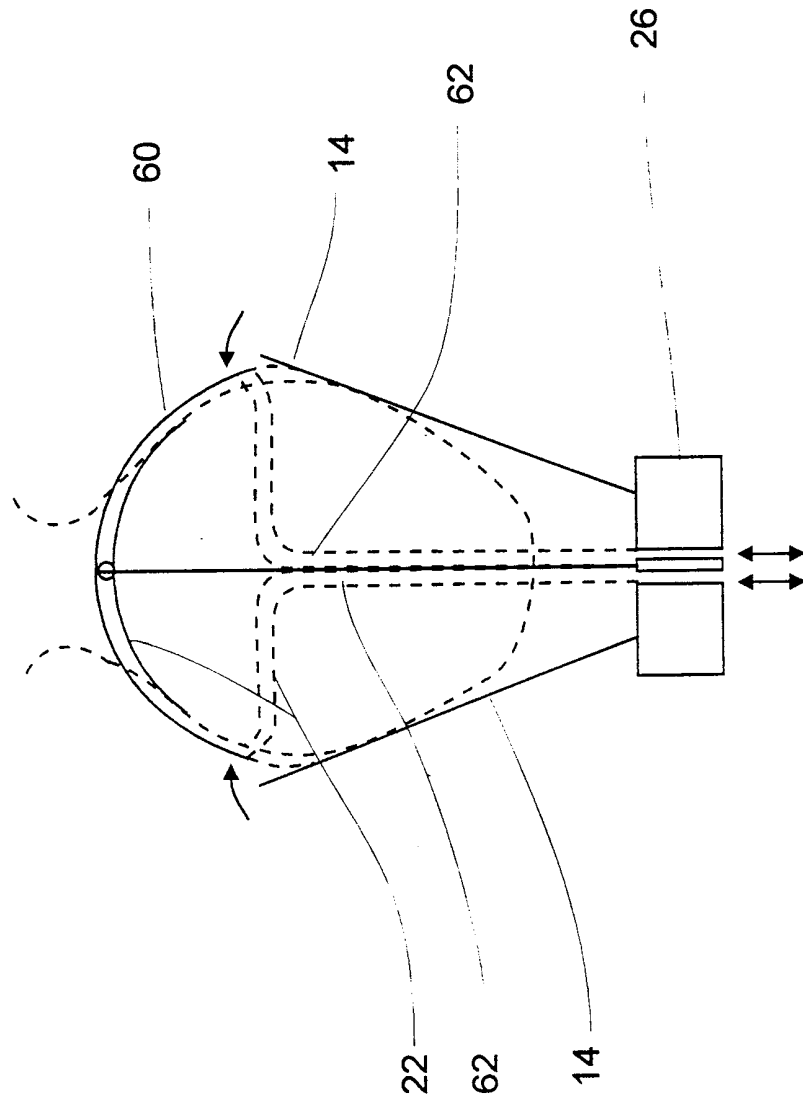

Fig. 10

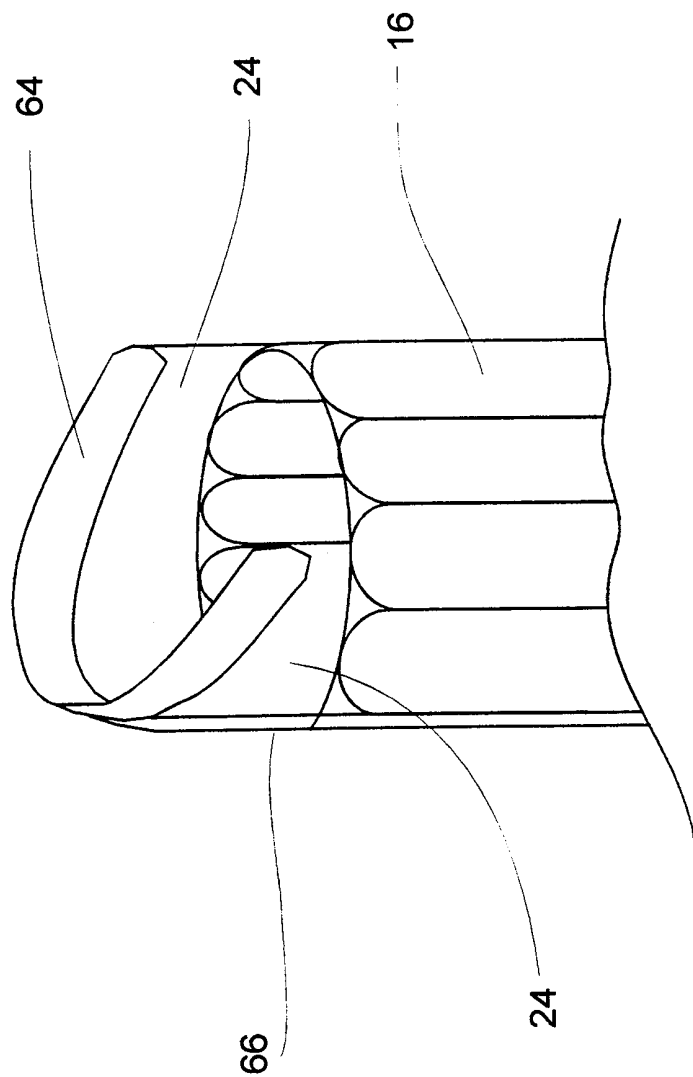

Fig. 11

INTERNATIONAL SEARCH REPORT

International application No.
PCT/IL98/00318

A. CLASSIFICATION OF SUBJECT MATTER

IPC(6) : A61B 17/00; A61F 2/04
US CL : 600/17; 623/3

According to International Patent Classification (IPC) or to both national classification and IPC

B. FIELDS SEARCHED

Minimum documentation searched (classification system followed by classification symbols)

U.S. : 600/17; 623/3

Documentation searched other than minimum documentation to the extent that such documents are included in the fields searched

Electronic data base consulted during the international search (name of data base and, where practicable, search terms used)

C. DOCUMENTS CONSIDERED TO BE RELEVANT

| Category* | Citation of document, with indication, where appropriate, of the relevant passages | Relevant to claim No. |
|-----------|--|-----------------------|
| Y | US 5,707,336 A (RUBIN) 13 January 1998 (13.01.98), entire patent. | 1-22 |

Further documents are listed in the continuation of Box C. See patent family annex.

| | |
|---|--|
| * Special categories of cited documents: | *T* later document published after the international filing date or priority date and not in conflict with the application but cited to understand the principle or theory underlying the invention |
| *A* document defining the general state of the art which is not considered to be of particular relevance | *X* document of particular relevance; the claimed invention cannot be considered novel or cannot be considered to involve an inventive step when the document is taken alone |
| *E* earlier document published on or after the international filing date | *Y* document of particular relevance; the claimed invention cannot be considered to involve an inventive step when the document is combined with one or more other such documents, such combination being obvious to a person skilled in the art |
| *L* document which may throw doubts on priority claim(s) or which is cited to establish the publication date of another citation or other special reason (as specified) | * & * document member of the same patent family |
| *O* document referring to an oral disclosure, use, exhibition or other means | |
| *P* document published prior to the international filing date but later than the priority date claimed | |

| | |
|---|--|
| Date of the actual completion of the international search 10 NOVEMBER 1998 | Date of mailing of the international search report 16 DEC 1998 |
|---|--|

Name and mailing address of the ISA/US
Commissioner of Patents and Trademarks
Box PCT
Washington, D.C. 20231
Facsimile No. (703) 305-3230

Authorized officer
David J Isabella
DAVID J ISABELLA
Telephone No. (703) 308-3060