

June 3, 1969

H. TEDER
ADJUSTABLE HEADSET

3,447,160

Filed Nov. 29, 1965

Sheet 1 of 2

FIG. 1

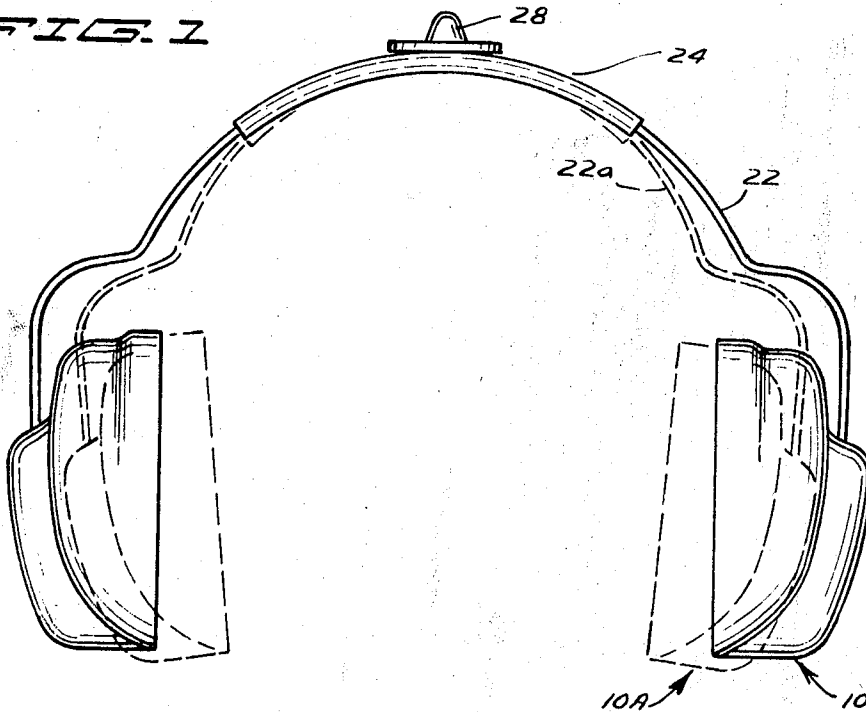

FIG. 2

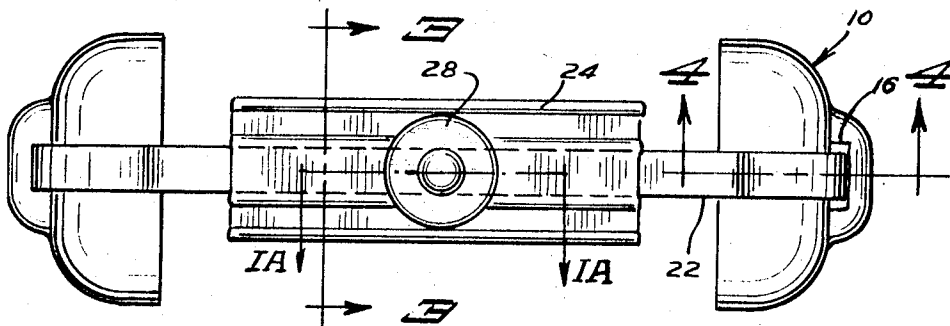

FIG. 3

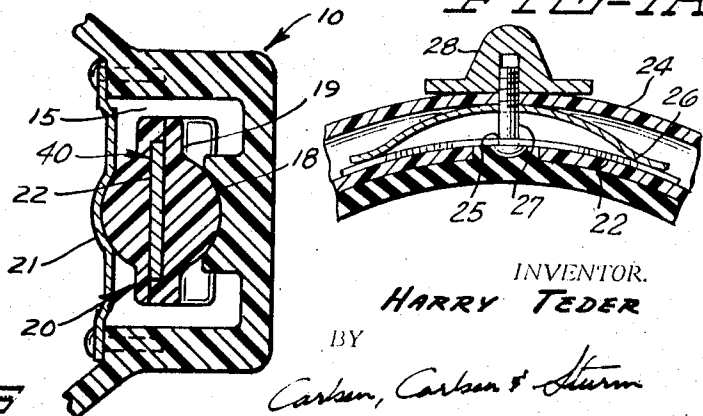
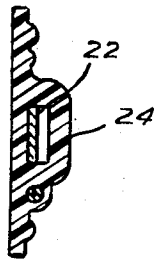

FIG-4A

FIG. 5

INVENTOR.
HARRY TEDER
BY
Carlsen, Carlsen & Sturm
ATTORNEYS

June 3, 1969

H. TEDER

3,447,160

ADJUSTABLE HEADSET

Filed Nov. 29, 1965

Sheet 2 of 2

FIG. 6

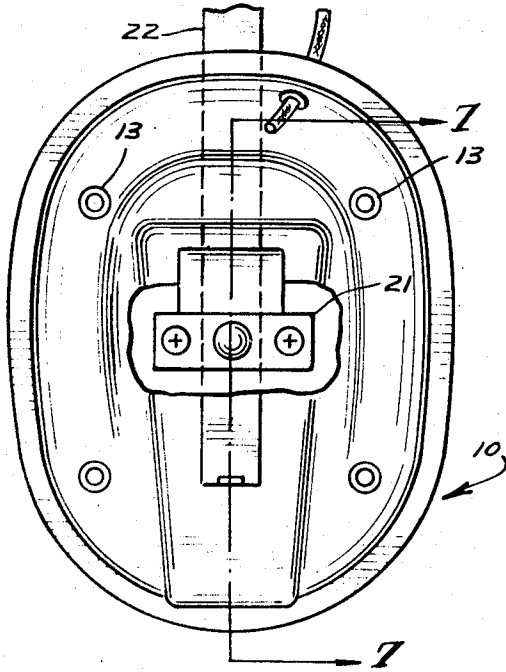

FIG. 4

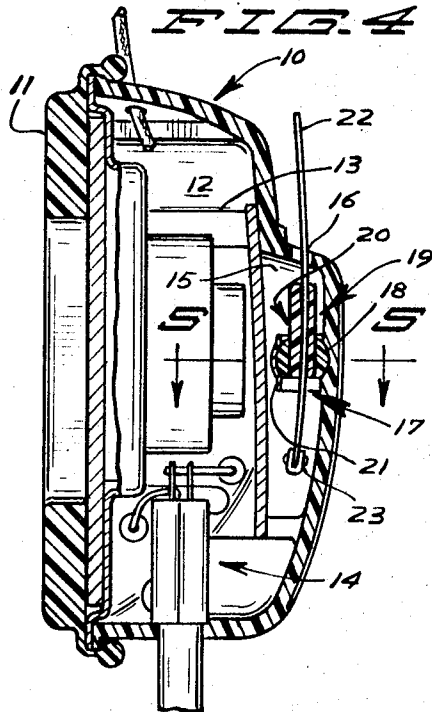

FIG. 7

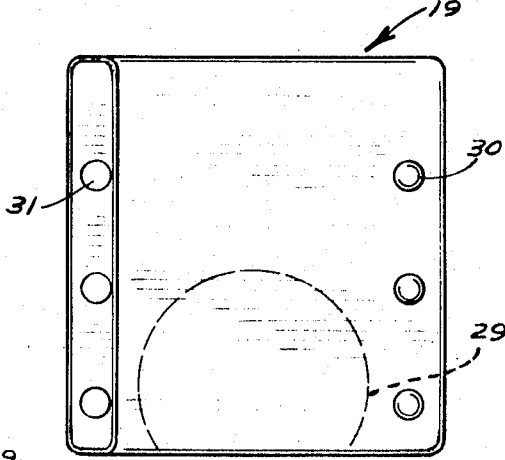
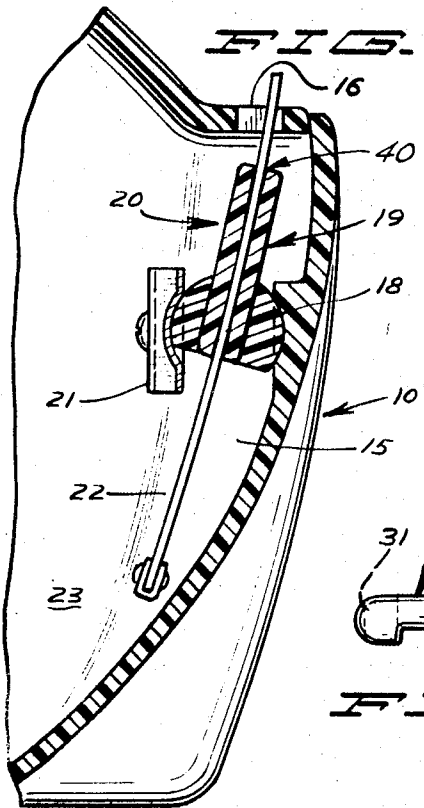

FIG. 8

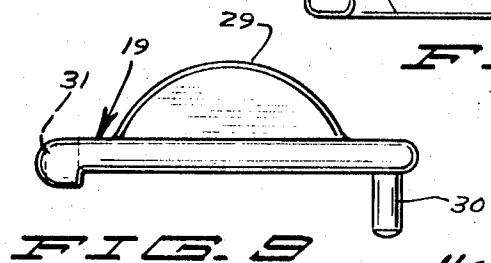

FIG. 9

INVENTOR.

HARRY TEDER

BY

Carlson, Carlson & Stinson

ATTORNEYS

1

2

3,447,160

ADJUSTABLE HEADSET

Harry Teder, Minneapolis, Minn., assignor to The Telex Corporation, Tulsa, Okla., a corporation of Delaware
Filed Nov. 29, 1965, Ser. No. 530,740
Int. Cl. A42b 1/06, 1/00

U.S. Cl. 2—209

5 Claims

ABSTRACT OF THE DISCLOSURE

A headset in which an ear cup is adjustably disposed with respect to a headband to provide a four degree freedom of motion. The ear cup is rotatable about three mutually perpendicular axes and reciprocally displaceable about one of the three axes. Further adjustability of the the U-shaped headband itself is provided through the cooperative relationship existing between a C-shaped member disposed on suitable adjusting means to variably bias the U-shaped headband and the ear cup adjustably appended thereto. The headband elements, including the U-shaped headband, the C-shaped member and adjusting means may also be contained within a sleeve like head pad to maintain proper operative relationship between the elements and to protect the same from undesired interference.

This invention relates generally to headsets and is more particularly directed to headsets of the adjustable class which are intended to be worn, comfortably, by individuals having wide variations in physical characteristics.

The prior art with which my invention is concerned contains numerous examples of constructions of headsets both fixed and adjustable. It is with regard to the adjustable type of headset that may be readily and easily adapted to conform to the physical characteristics of a particular individual that the present invention is intended to present particularly useful advantages. In many of the prior art adjustable headsets, a highly complicated and unwieldy combination of elements has generally been used which, most often, falls short of providing the necessary manner and range of adjustment to provide proper fitting and comfortable wearing of a headset, particularly over long periods of time. A further disadvantage of the known prior art headsets is seen in exposed working parts which are subject to becoming entangled with various portions of the headset itself e.g. the cord, and/or external objects with which the headset may come in contact with both when in operative disposition on the head of an individual or when not in actual use.

It is therefore an object of my invention to provide an improved fully adjustable headset.

Another object of my invention is to provide an improved headset in which the elements providing adjustability therefor are enclosed.

A further object of my invention is to provide an improved headset that is simple in construction, inexpensive to manufacture and relatively easy to use.

Another object of my invention is to provide an improved apparatus for adjusting the tension of the headband in a headset.

A still further object of my invention is to provide an improved mounting and suspension means for an ear muff on a headset.

Another object of my invention is to provide an improved suspension and mounting for an ear muff on a headset in which the working parts are enclosed.

A still further object of my invention is to provide an improved mounting and suspension for an ear muff on a headset which provides a four degree adjusta-

bility of the ear muff with respect to the headband on a headset.

A still further object of my invention is to provide an improved mounting and suspension for an ear muff on a headset that is simple and inexpensive to manufacture.

With these and other objects in view, it may be seen that my improved headset is comprised of a flat substantially U-shaped headband that is provided with means intermediate its ends, at the closed end of the U, for adjustably controlling the spring tension applied to the remotely disposed ends of the U-shaped headband. One or more ear muffs are mounted and suspended from an end portion of the U-shaped headband by an improved mounting means which exhibits a four degree adjustability in that the end of the headband is slidably retained between a pair of bearing elements that are internally journaled inside of the ear muff in such a manner as to provide a limited three degree freedom of motion of the bearing elements and may be constructed to have a range of freedom of motion that is ample to accommodate the differing physical characteristics of various individuals.

Other objects and advantages of my invention may become apparent from a consideration of the appended specification, claims and drawings, in which:

FIG. 1 is a front elevation view of a complete headset;

FIG. 1A is an enlarged fragmentary sectional view of the headband adjusting means for the headset;

FIG. 2 is a top plan view of the headset of FIG. 1;

FIG. 3 is a sectional view taken along section line 3—3 in FIG. 2;

FIG. 4 is an enlarged sectional view of a portion of the headphone taken along section line 4—4 in FIG. 2;

FIG. 5 is an enlarged sectional view of the mounting and suspension means taken along section line 5—5 in FIG. 4;

FIG. 6 is a front elevation view of an ear muff partly broken away to show a portion of the mounting and suspension means;

FIG. 7 is an enlarged fragmentary sectional view of the mounting and suspension means; and

FIGS. 8 and 9 comprise a side elevation and top plan view of the bearing members utilized in the mounting and suspension means.

Referring to FIGS. 1 and 2 of the drawing, there is shown a headband assembly comprised of a generally U-shaped headband member 22 and a pair of ear muff housings 10 attached to the downwardly depending ends thereof. Each of the right and left ear muff housings are adapted to be disposed over the ears of a user and, in FIG. 1, an alternate position of ear muffs 10 and headband 22 are indicated by reference characters 10A and 22A to indicate that a range of adjustability intermediate the ends of headband 22 may be effected by an adjusting means, including a screw threaded adjusting device 28, disposed in aperture 25 intermediate the ends of headband 22.

An enlarged fractional sectional drawing of the means for providing this adjustment is shown in FIG. 1A in which an upwardly extending screw threaded stud member 27 is stationarily disposed on headband member 22, a substantially C-shaped adjustable spring member 26, having an aperture intermediate its ends, is slidably disposed on stud 27 and the end extremities are disposed on top of headband 22 on opposite sides of its midpoint. A screw threaded adjustment member 28 is threadedly disposed on the top of stud member 27 so as to provide an adjustment to increase or decrease the tension applied to the top surface of headband 22 by the end extremities of

adjustable spring member 26 as determined by the relative position of its center portion with respect to the top of the midpoint of headband 22. It should be apparent that the greater the distance, the smaller the force that will be exerted upon headband 22 and hence the force exerted inwardly of the ends of headband 22 will be dependent upon the relative position of the center portion of adjustable spring member 26 with respect to the top of the midpoint of headband 22. This therefore constitutes one adjustment of the headset assembly which may be used to vary the engagement of the head engaging portions of muff housings 10 with the ears, or head, of an individual to provide the desired degree of comfort in wearing the headset and the desirable coupling of the sound emanating from within muff housings 10 to be applied to the ear canal of the individual. Headband 22 may be comprised of material exhibiting substantial resilience characteristics. It might also be noted at this point that the center portion of headband 22 and the adjustment means for adjusting the inwardly directed forces at the end extremities thereof may be suitably disposed within a pad member, shown as sleeve 24, which is adapted to enclose not only headband 22, and adjustable spring 26, but a cable that would normally be used to interconnect a pair of ear muff housings on a headset assembly in which a pair of transducers is utilized to apply sound energy to both ears of an individual. Pad 24 is desirable not only because of possible comfort to the wearer but also to protect and encase, within its interior confines, the working parts concerned with controlling the inward forces applied to ear muffs 10 at the end extremities of headband 22 for the purposes noted above.

In FIGS. 4, 5, 6 and 7 an ear muff housing 10 is shown as including an ear cushion 11 that is adapted to engage the head of an individual adjacent the external portions of the ear, a transducer chamber 12 that is adapted to receive and hold a transducer, for example a receiver, for generating sound energy to be applied to the ear canal of an individual, a means 13, for mounting a transducer 12, a plug receptacle 14 for receiving a plug to connect a cable (not shown) to a source of electrical energy and a headband receiving chamber 15 having an upwardly opening slot, 16, at its top end for receiving the end extremity of a headband, 22. Chamber 15 is also shown provided with a spherical portion 18 that is adapted to receive and rotatably journal a spherical bearing and a bearing spring 21 having a like configured spherical journal portion that is adapted to receive and rotatably journal a bearing member. Disposed intermediate the journaling portion 18 of chamber 15 and the center portion of bearing spring 21, is a pair of like configured bearing members 19 and 20 which are complementary shaped to provide an interior channel 40 that is adapted to slidably receive and frictionally engage one of the end extremities of headband 22. Each of the bearing members is provided with an outwardly extending spherical shaped protuberance that is adapted and dimensioned to be rotatably received in spherical journal 18 in chamber 15 and the center portion of bearing spring 21.

In FIG. 7, headband 22 is shown extending downwardly through slot 16, through the channel 40 defined intermediate bearing members 19 and 20 and downwardly for a considerable distance into chamber 15. The end extremity of headband 22 is shown provided with a stop member 23 to prevent complete withdrawal of headband 22 through the channel intermediate bearing members 19 and 20. It may thus be seen that one degree of freedom of motion is determined by the slidable, frictional engagement of the outside surfaces of headband 22 with the channel 40 formed intermediate complementary configured bearing members 19 and 20 so that the ear muff housing 10 may be moved upwardly and downwardly with respect to the end extremities of headband 22. A three degree freedom of rotational motion about three

mutually perpendicular axes is provided by the spherical protuberance 29 extending outwardly from bearing members 19 and 20 in cooperation with the like, complementary shaped, spherical journals provided in chamber 15 as indicated at the center portion of bearing spring 21 and by reference character 18. Bearing spring 21 provides a biasing force toward journal 18.

Bearing members 19 and 20, as indicated above, may preferably be comprised of like elements as illustrated in FIGS. 8 and 9 which, when assembled in the manner shown in FIG. 5 of the drawings, comprise a complete bearing assembly. In FIGS. 8 and 9, bearing member 19 is shown as having a plurality of apertures 31 at its left side and a plurality of pin members 30 at its right side and a centrally disposed spherical protuberance 29 adjacent its bottom edge. It should be apparent that a like configured bearing member 20 may be assembled in the manner shown, for example, in FIG. 5 of the drawings, to comprise a complete bearing assembly which, when disposed on the lower extremity of headband 22, provides a mounting assembly for ear muff housing 10 that will allow for sliding adjustment along one axis and rotational motion about three mutually perpendicular axes, one of which is disposed in a substantially vertical attitude, to provide a four degree freedom of motion and adjustment of the ear muff housing with respect to the end extremities of headband 22.

Operation

In operation, my apparatus is disposed on the head of an individual with ear muffs 10 in the usual proximity to the external ear portions of the individual. The necessary vertical adjustment is performed by physically sliding ear muffs 10 on the ends of headband 22 to approximately center the external portion of the ear within ear cushion 11. Internally screw threaded element 28 is then utilized to adjust the inward tension exerted by the end extremities of headband 22 to effect the seal between ear cushion 11 and the head of the individual which provides a maximum comfort and maximum exclusion of external sound energy. The coaction between the spherical protuberance 29 on bearing members 19 and 20 and the journals provided therefor within chamber 15 and ear muffs 10 provides the necessary three degree freedom of motion to allow ear muffs 10 and ear cushion 11 to conform to the shape of the head of the individual.

It is understood that suitable modifications may be made in the structure as disclosed, provided such modifications come within the spirit and scope of the appended claims. Having now therefore fully illustrated and described my invention, what I claim to be new and desire to protect by Letters Patent is:

1. A headset comprising:

- (a) at least one ear muff, said ear muff having an opening formed in a top surface thereof and a chamber in communication with said opening;
- (b) a generally C-shaped, resilient headband member, having at least one end of non-circular cross section, extending through said opening into the chamber in said ear muff;
- (c) bearing means, having a channel therethrough, frictionally, slidably disposed on said end of said headband; and
- (d) means journaling said bearing for rotation about three mutually perpendicular axes, said last named means being disposed within the chamber in said ear muff.

2. The apparatus of claim 1 in which the bearing means includes a pair of opposed outwardly extending semi-spherical portions and the means for journaling said bearings is comprised of a like pair of opposed, spaced apart, semispherical surfaces of complementary configuration with respect to said bearing means.

5

3. The apparatus of claim 2 in which the bearing means is comprised of a pair of like configured members and the means journaling the bearings includes means for resiliently biasing said bearing members toward one another and into frictional, slidable engagement with said one end of the headband member.

4. The apparatus of claim 1 in which the headband member includes an upwardly extending stud disposed intermediate the ends thereof, and a resilient C-shaped member, having a centrally disposed aperture formed therein is slidably disposed on said stud and the ends thereof are in engagement at spaced positions toward the ends of said headband member and adjusting means are disposed on said stud for controlling the engagement of the C-shaped member with said headband member.

5. The apparatus of claim 4 in which a sleeve member is disposed over the central portion of the headband member and the C-shaped member.

5

10

15

6

References Cited

UNITED STATES PATENTS

894,258	7/1908	Cobb	179—156
2,150,703	3/1939	Stetson	24—255
2,420,245	5/1947	Hurst	2—209
3,148,376	9/1964	Aileo	2—209 XR
3,261,028	7/1966	Coletta	2—209

FOREIGN PATENTS

231,643	4/1925	England.
446,230	6/1927	Germany.

JORDAN FRANKLIN, *Primary Examiner.*

G. H. KRIZMANICH, *Assistant Examiner.*

U.S. Cl. X.R.

179—156