

[54] **POWER OPERATED FLUID INFUSION DEVICE**

458,275 7/1950 Italy..... 128/218 A

[75] Inventors: **Anthony W. Szabo**, Livingston, N.J.;
Louis R. M. Del Guercio,
Larchmont, N.Y.

Primary Examiner—Richard A. Gaudet
Assistant Examiner—J. C. McGowan
Attorney, Agent, or Firm—Larson, Taylor and Hinds

[73] Assignee: **Anthony Scala**, Livingston, N.J.; a part interest

[22] Filed: **Oct. 23, 1973**

[57] **ABSTRACT**

[21] Appl. No.: **408,264**

[52] U.S. Cl..... **128/218 A; 128/214 F; 128/218 F**

[51] Int. Cl..... **A61m 5/20**

[58] Field of Search 128/218 A, 218 F, 215,
128/234, 214 F, 218 R, DIG. 1, DIG. 12, 214
R; 222/386

A portable, power operated fluid infusion device is disclosed for automatically, intravenously administering a drug to a patient. The device comprises a housing which contains a mechanically operated timing mechanism, a rack in engagement with a pinion rotated by the timing mechanism, and spiral springs for longitudinally urging the rack in a forward direction. Attached to the forward end of the housing in axial alignment therewith and with the rack is a syringe which has an internal axially movable piston that is coupled to and longitudinally moved by the rack. The springs assist the slowly rotating pinion to positively move the rack, and hence the piston, in a longitudinal direction thereby permitting a controlled amount of the drug to be automatically expelled from the syringe over an extended period of time.

[56] **References Cited**
UNITED STATES PATENTS

2,498,672	2/1950	Glass.....	128/218 A
2,531,267	11/1950	Harnisch	128/218 F
2,605,765	8/1952	Kollman.....	128/218 F
2,671,448	3/1954	Harnisch	128/218 F
3,384,080	5/1968	Muller.....	128/214 F
3,701,345	10/1972	Heilman et al.	128/218 A

FOREIGN PATENTS OR APPLICATIONS

1,026,593	4/1966	United Kingdom.....	128/218 A
-----------	--------	---------------------	-----------

2 Claims, 5 Drawing Figures

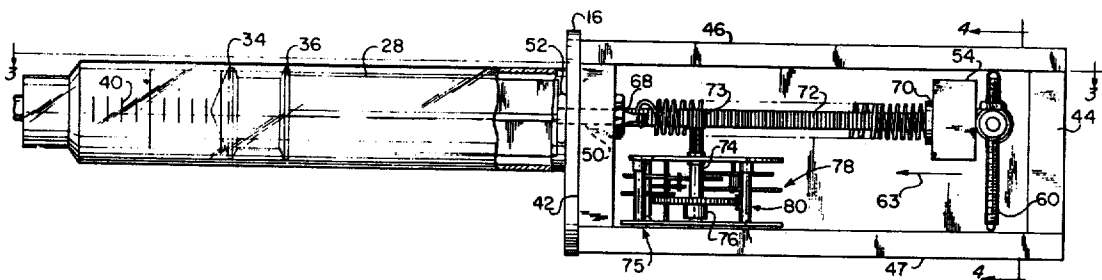

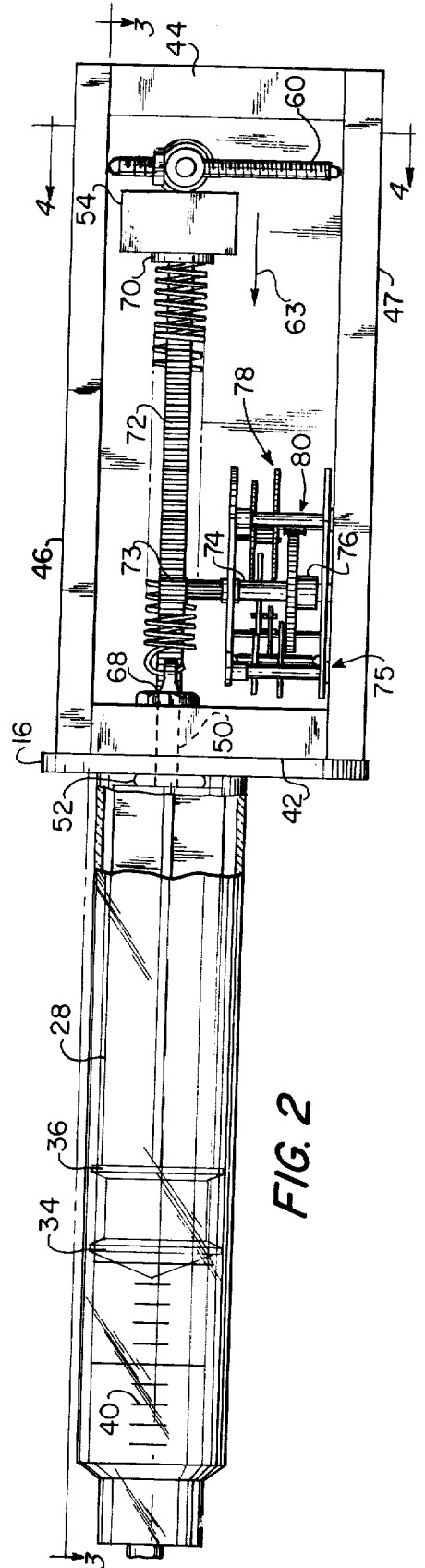
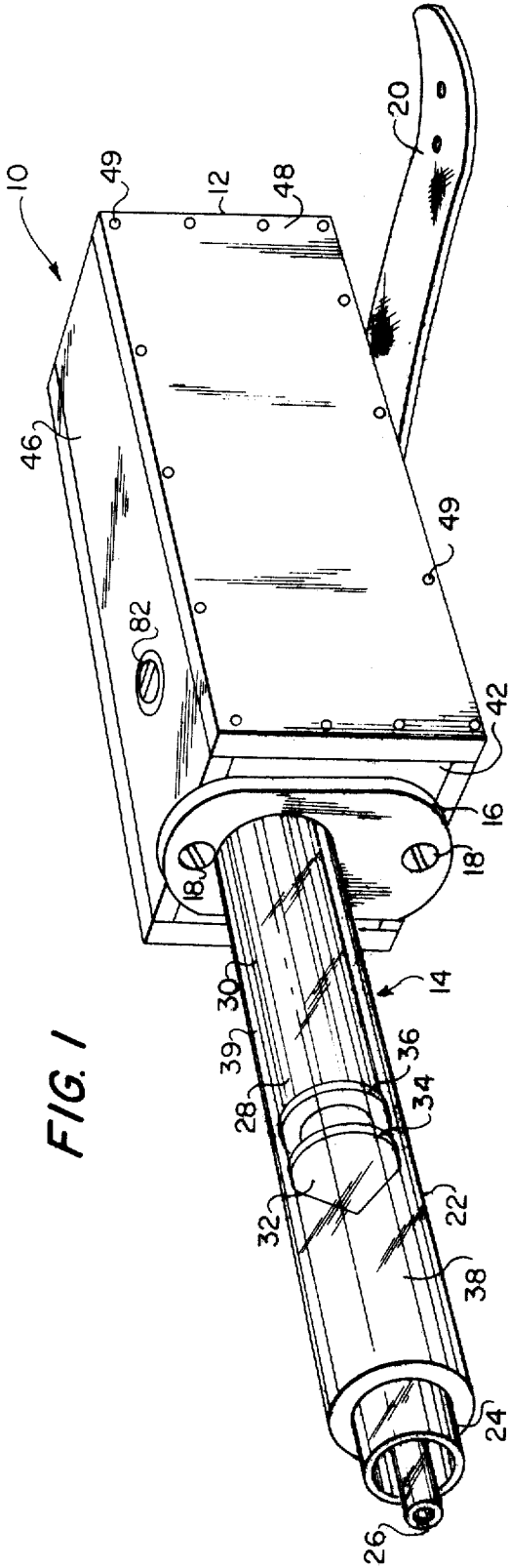

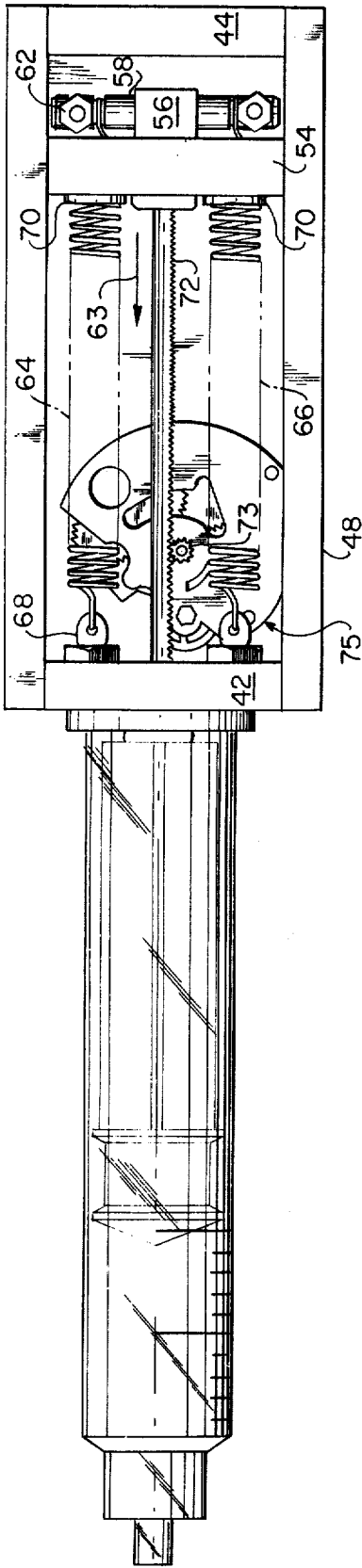

FIG. 3

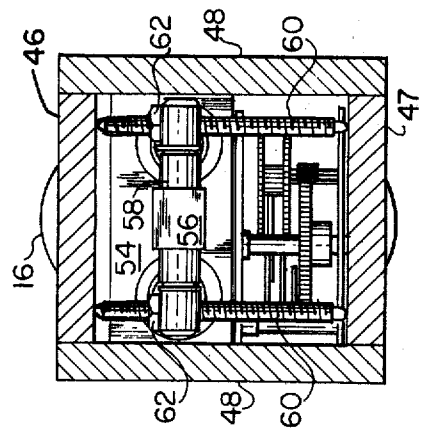

FIG. 4

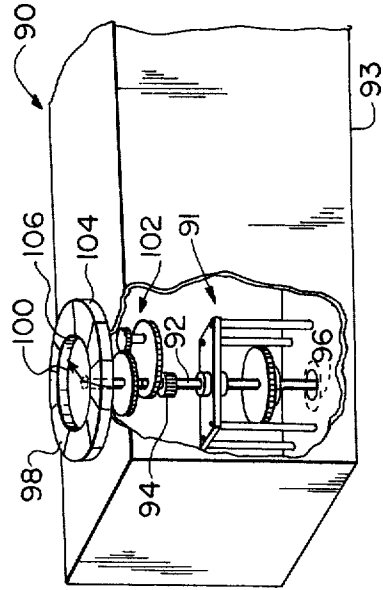

FIG. 5

POWER OPERATED FLUID INFUSION DEVICE

BACKGROUND OF THE INVENTION

1. Field of the Invention

This invention relates to portable, automatic fluid infusion devices and more particularly to a low pressure, highly reliable, completely mechanically driven infusion syringe device which permits automatically controlled drug infusion over an extended time period.

2. Description of the Prior Art

In a modern hospital complex, medical personnel are increasingly being called upon to perform numerous, time consuming activities. Consequently, as constantly increasing demands are made for the time of limited number of medical personnel, it has been found that the frequency of late performance or omitted performance of the more routine activities, such as the administering of injections, has increased. Certain illnesses, such as pulmonary embolus require treatment by administering daily numerous, periodic injections of the same drug. By easing of the burden of repeatedly administering these injections by hospital personnel would provide more time for other activities. Furthermore, the omission of the delay in administering the injections can in some cases result in serious consequences. Not only is the frequent administering of the injections time consuming, it is also an additional expense for the patient.

One solution to the problem of having to frequently administer injections has been to confine the patient to a bed and to administer the medicine as a fluid with a gravity bed bottle system. The system comprises a bottle containing the fluid suspended above the patient, a needle inserted into a vein or artery of the patient, and tubing connecting the bottle to the needle. An obvious disadvantage of the bottle system is that it unnecessarily confines an other wise ambulatory patient to a bed. Other disadvantages of the bottle system are non-adaptability for administering fluids to animals and non-capability of use with viscuous fluids.

There is prior art which attempts to remedy the aforementioned problems by utilizing syringes that are operated by electrical motors. Initially, it was believed that devices that use small electric motors to operate linkage which depresses the plunger of a standard syringe, would overcome all the aforementioned problems. However, these devices have proven unsatisfactory for a number of reasons. Most importantly, it was discovered that any introduction of electricity into the body, even on the order of microamperes and irrespective of whether the electricity is AC or DC, can cause heart fibrillations. In addition, besides being very expensive, these devices are not reliable since a loss of power, either due to a defective unit or a deenergized battery, would result in an undetectable inoperative device.

Thus, there is a need for a completely safe, nonelectrical, positive-acting, power operated syringe which is inexpensive and can be easily worn on the arm or leg of an ambulatory patient or can be strapped to the body of an animal. None of the known prior art devices have positive acting gearing mechanism for driving a member to force a viscuous therapeutic drug fluid out of an infusion device.

SUMMARY OF THE INVENTION

The present invention provides a highly reliable, por-

table fluid infusion device that automatically discharges a predetermined amount of fluid continuously over an extended time period. Furthermore, the present invention is completely portable, light weight, attachable to an ambulatory patient or animal, and can be inexpensively made so that after its use it can be permanently discarded.

Included in the present invention is a housing, a syringe mounted on the housing, the syringe comprising an elongated container having an orifice in one end thereof and a piston mounted for longitudinal movement within the container for forcing a fluid stored in the container through the orifice, and a mechanical timing mechanism mounted on the housing. The timing mechanism includes a main spring, an escapement mechanism, a gearing mechanism rotated by the main spring at a rate controlled by the escapement mechanism, a rotatable main shaft extending outwardly from the gearing mechanism and rotated thereby, the main shaft having a pinion mounted on the outwardly extending end thereof, and a member for winding the main spring of the timing mechanism. A rack engages the pinion of the timing mechanism and is integral with a longitudinally movable member which is coupled to the piston of the syringe, thereby longitudinally moving the piston at a predetermined rate and consequently forcing fluid at a predetermined rate through the orifice. The rack is urged in a longitudinal direction and into engagement with the piston for the longitudinal movement of the latter by a spring, the pinion of the timing mechanism restraining the longitudinal movement of the rack to a predetermined rate which is determined by the rotational speed of the pinion.

Other features and advantages of the invention will be set forth in, or apparent from, the detailed description of the presently preferred embodiments thereof found hereinbelow.

BRIEF DESCRIPTION OF THE DRAWINGS

In the drawings in which like reference numerals denote like elements:

FIG. 1 is a perspective view of a presently preferred embodiment of the invention;

FIG. 2 is a front elevation view of the invention wherein one side of the housing has been removed for illustrating the internal parts thereof;

FIG. 3 is a longitudinal cross sectional view of the invention taken along line 3—3 of FIG. 2;

FIG. 4 is a transverse cross sectional view taken along line 4—4 of FIG. 2, and

FIG. 5 is a perspective view with part of the housing broken away of a section of a second embodiment of the invention.

DETAILED DESCRIPTION OF A PREFERRED EMBODIMENT

With reference to FIG. 1, a presently preferred embodiment of a fluid infusion apparatus 10 is shown according to the invention. Apparatus 10 is comprised of a longitudinally extending, rectangular housing 12 and a syringe 14 removably mounted at one end of housing 12 in axial alignment therewith with means such as mounting plate 16 and screws 18. A strap 20 is fixedly mounted on housing 12 and provides a means by which apparatus 10 can be attached to a body portion of a patient.

Syringe 14 is comprised of an elongated cylindrical container 22 having an end 24 distal from housing 12. In distal end 24 is an orifice 26 for permitting communication between the interior of container 22 and a hypodermic needle (not shown) which can be removably attached at distal end 24. An elongated piston 28 is mounted for longitudinal movement inside container 22. Piston 28 is comprised of a head section 32 integral with an elongated shaft 30 which extends into the inside of housing 12. Head section 32 is divided into a forward section 34 and a rearward section 36. Forward section 34 and rearward section 36 form an annular forward and rearward seal, respectively, with the internal wall of container 22. Consequently, piston 28 divides the internal volume of container 22 into a forward chamber 38 for containing a fluid which is to be injected into the patient, and a rearward section 39 which is kept free from the fluid through the sealing action of forward section 34 and rearward section 36 of the piston head section 32. Container 22 is preferably made of a transparent, nonporous material, such as glass or a plastic. It is common practice to have graduations, such as graduations 40 in FIG. 2, etched or otherwise marked on the surface of container 22 so that the amount of fluid remaining in the chamber 38, and the position of piston 28 inside container 22 can be determined. Graduations 40 can be marked off either in fluid volume or in time intervals of, for example, every two hours.

Housing 12 of fluid infusion apparatus 10 can conveniently be manufactured in relatively small dimensions such as, for example, 1 by 1 inch square in transverse cross section by two and a half inches long. In other embodiments of the invention, the housing can have different transverse cross sectional shapes, such as rectangular or elliptical, and can have dimensions of, for example, three-quarter by 1 inch. Many, easily available, strong, and light weight materials can be used for the construction of housing 12 and include, for example, aluminum, stainless steel, and certain polymer plastic materials. Housing 12 is comprised of a forward end 42, a rear end 44, a front panel 46, a back panel 47, and lateral sides 48 which are removably mounted on ends 42 and 44 and front and back panels 46 and 47 with means such as screws 49.

With reference to FIG. 2, there is shown a coupling member 50 attached at a forward end to and in longitudinal axial alignment with shaft 30 of piston 28. Member 50 extends through a seal 52 located in forward end 42 of housing 12 and into the interior of housing 12. Rigidly mounted near the rearward end of coupling member 50 is a base 54 which extends transversely to and slidably engages with sides 48 of housing 12. Base 54 centers and maintains the axial alignment of coupling member 50 with piston 28 in a first, transverse plane during the longitudinal movement of these components. As best shown in FIGS. 3 and 4, coupling member 50 terminates at its rearward end in a collar 56 which has an axial bore that extends in the first transverse plane. Rigidly mounted within the bore of collar 56 and extending on either side thereof is a shaft 58. Two threaded guide members 60 are mounted at respective ends of shaft 58 in a perpendicular direction thereto and are secured to shaft 58 with fastening means such as nuts 62. Guide members 60 slidably engage front panel 46 and back panel 47 of housing 12 for maintaining axial alignment between coupling member

50 and piston 28 in a second transverse plane, which is perpendicular to the aforementioned first transverse plane, during the longitudinal movement of coupling member 50 and piston 28.

Coupling member 50, and consequently piston 28, is urged in a forward longitudinal direction, indicated by an arrow 63, by two elongated helical springs 64 and 66. The forward ends of both spring 64 and spring 66 engage an anchoring member such as, for example, eye bolts 68. Bolts 68 are, in turn, fixedly mounted on forward end 42 of housing 12. The rearward end of springs 64 and 66 are rigidly secured to base 54 with means such as couplings 70. Thus, as springs 64 and 66 compress, piston 28 is urged into container 22 to force fluid out through the hypodermic needle.

Coupling member 50 includes along its midportion a rack 72 integral therewith. Engaging rack 72 is a pinion 73 mounted on and integral with the end of main shaft 74 which extends outwardly from a mechanical timing mechanism 75. Timing mechanism 75 is a conventional, manually wound time piece which includes a main spring 76 that conventionally operates or rotates a gearing mechanism 78 at a rate controlled by an escapement mechanism, generally shown at 80 in a manner that is well known in the art. Main spring 76 of timing mechanism 75 is manually wound by the rotation of winding screw 82, shown in FIG. 1. As is shown in FIG. 1, winding screw 82 is accessible from the exterior of housing 12 and is conveniently recessed in front panel 46. In another embodiment as shown in FIG. 2, screw 82 (not shown in the figure) is recessed in back panel 47.

In operation, fluid infusion apparatus 10 can be used to inject heparin, a drug which prevents blood clotting and is intravenously administered over an extended period of time to patients who have had, for example, a pulmonary embolus. If fluid infusion apparatus 10 is of the reusable type, a prefilled syringe is mounted onto the housing 12 subsequent to the positioning of coupling member 50 in its most rearward position, as shown in FIG. 2. This is accomplished by rotating winding screw 82, and consequently pinion 73, which in turn, longitudinally positions rack 72 and coupling member 50. The hypodermic needle of syringe 14 is then inserted into the vein of the patient at an appropriate location, such as in the arm, and fluid infusion apparatus 10 is mounted on the arm by means of strap 20. Mechanical timing mechanism 75 is selected such that pinion 33 will permit the full longitudinal travel of coupling member 50 in the time period desired to administer the drug.

A second embodiment of a fluid infusion device according to the invention, denoted 90, is shown in FIG. 5 and is similar to fluid infusion device 10 described hereinabove, except that it further includes an elapsed time and expended fluid indicator. Fluid infusion device 90 includes a mechanical timing mechanism 91 which is similar to mechanical timing mechanism 75 shown in FIGS. 2, 3 and 4 and also described hereinabove. However, mechanical timing mechanism 91 includes a main shaft 92 which extends completely through the housing 93 of fluid infusion device 90, and a pinion 94 mounted on main shaft 92 at the middle portion thereof. Located at one end of main shaft 92 is a winding screw 96, shown in phantom, for winding mechanical timing mechanism 90, and located at the other end of main shaft 92 is an indicator gauge 98 that is

mounted on the exterior of housing 93. Gauge 98 has a pointer 100 which is connected by reduction gears 102 to main shaft 92 and rotated thereby. Indicia on the face of gauge 98 indicates elapsed time in two hour increments at an outer ring 104 and expended solution in cubic centimeters at an inner ring 106. Thus, mechanical timing mechanism 91 can be wound by winding screw 96 to any desired time as indicated by gauge 98. Furthermore, the amount of the fluid which has been injected and the elapsed time since the injection has started, or the time remaining to complete the injection, can be readily and easily determined by reading gauge 98.

It is apparent from the foregoing that the fluid infusion apparatus of this invention supplies a constant feeding of a therapeutic fluid in a controllable amount of flow over an extended period of time. Other embodiments of the invention can provide for an automatic, periodic, intermittent, infusion of a fluid contained within the syringe, or for a manually controllable intermittent infusion of the fluid. Furthermore, still another embodiment of the invention can provide for a variable flow rate of the fluid.

Although the invention has been described in detail with respect to an exemplary embodiment thereof, it will be understood by those of ordinary skill in the art that variations and modifications may be effected within the scope and spirit of the invention.

I claim:

1. Portable, automatic fluid infusion apparatus for administering a predetermined amount of fluid at a predetermined rate over an extended time period, the device comprising

- an elongate housing attachable to a user;
- a syringe mounted at one end of said housing in axial alignment therewith said syringe comprising an elongated container having an orifice through one end thereof and a piston mounted for longitudinal movement within said container for forcing fluid through the said orifice;
- a mechanical power means coupled to and in axial alignment with said piston for longitudinally moving said piston, said power means including rack means;
- a mechanical timing mechanism mounted on said housing and coupled to said power means for permitting only a predetermined rate of longitudinal movement of said piston by said power means,

thereby providing a predetermined flow of said fluid from said syringe, said mechanical timing mechanism including a main spring, an escapement mechanism, gearing mechanism connected to and rotated by said main spring, said escapement mechanism permitting a controlled rate of rotation of said gearing mechanism, a rotatable main shaft extending outwardly from said gearing mechanism and rotated thereby, said main shaft having a pinion mounted at the outwardly extending end thereof and in engagement with said rack means, and means for winding said main spring,

a first centering means transversely rigidly mounted on said rack means for bearing against opposite sides of said housing during the longitudinal movement of said rack means for maintaining the axial alignment of said rack means and said piston in a first, transverse plane;

a second centering means transversely, rigidly mounted on said rack means perpendicular to said first centering means for bearing against at least one further side of said housing, other than said opposite sides, during the longitudinal movement of said rack means for maintaining the axial alignment of said rack means and said piston in a second, transverse plane, said second transverse plane being perpendicular to said first transverse plane; and

a helical spring attached at a first end to the end of said housing at which said syringe is mounted and attached at the other end to said first centering means for longitudinally urging said rack means into engagement with said piston for the longitudinal movement thereof, said pinion of said mechanical timing mechanism restraining the longitudinal movement of said rack means to a predetermined rate determined by the rotational speed of said pinion, and thereby permitting a predetermined amount of fluid to be forced by said piston through said orifice during a predetermined time.

2. Fluid infusion apparatus as claimed in claim 1 wherein said syringe is removably mounted at one end of said housing in axial alignment therewith, and said power means is mounted within and totally enclosed by said housing in axial alignment with said piston of said syringe.

* * * * *

50

55

60

65