

Finished Size: 44 1/2" x 44 1/2" (113.03cm x 113.03cm)

## Songbirds Quilt

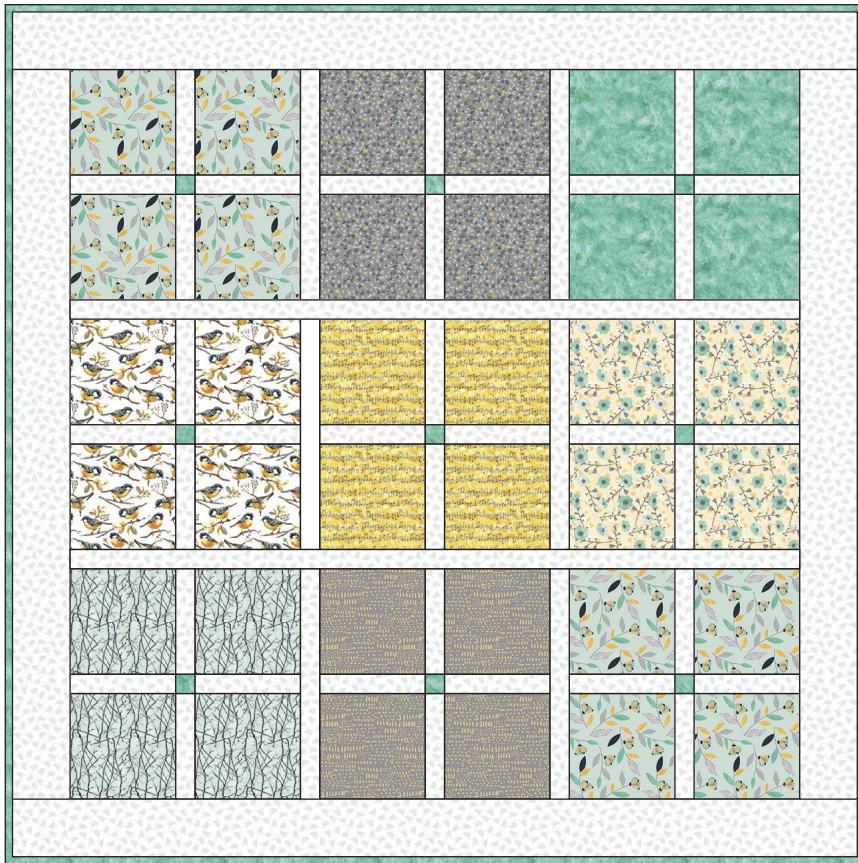

### Supplies Needed

3 Wishes Fabric® Songbirds Collection

- 1 3/8 yds. (125.73cm) — 12237-White
- 5/8 yd. (57.15cm) — 12239-Turq for pieces and binding
- 3/8 yd. (34.29cm) — 12236-Turq
- 1/4 yd. (22.86cm) — 12231-White
- 1/4 yd. (22.86cm) — 12233-Turq
- 1/4 yd. (22.86cm) — 12234-Gray
- 1/4 yd. (22.86cm) — 12235-Yellow
- 1/4 yd. (22.86cm) — 12238-Gray
- 1/4 yd. (22.86cm) — 12240-Gold
- 2 yds. (182.88cm) — 12235-Yellow for backing
- 50" x 50" (127cm x 127cm) Cotton batting
- Coordinating thread
- Rotary cutter (45mm), cutting mat with lines
- Acrylic ruler 6" x 24" (15.24cm x 60.96cm)
- Fine straight pins
- Safety pins (size 1 for basting)
- Basic sewing supplies
- Sewing machine
- Walking foot (for quilting)
- Iron and pressing surface
- Masking tape

### Before you begin

Read all instructions before beginning project. Do not pre-wash fabrics. Press fabrics with a dry iron on cotton setting before cutting. Use a 1/4" (6.35mm) seam allowance and sew fabrics with right sides together (RST) unless otherwise noted. Press seams in the directions of the arrows. Wof = width of fabric.

### Cutting

1. Use a rotary cutter and acrylic ruler to cut the number of pieces from each fabric as shown.

12238-Gray  
¼ yd. (22.86cm)

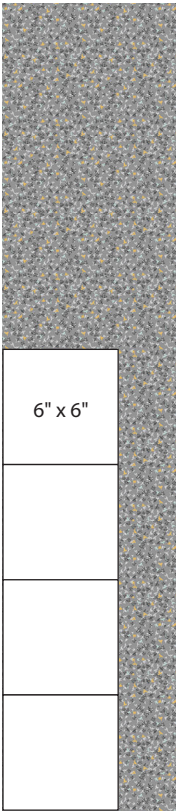

Cut 4 - 6" x 6"  
(15.24cm x 15.24cm)

12231-White  
¼ yd. (22.86cm)

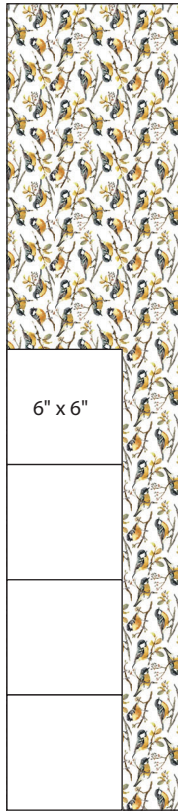

Cut 4 - 6" x 6"  
(15.24cm x 15.24cm)

12233-Turq  
¼ yd. (22.86cm)

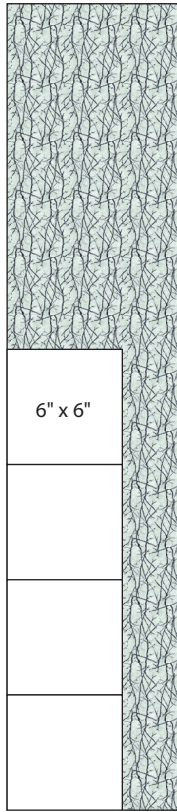

Cut 4 - 6" x 6"  
(15.24cm x 15.24cm)

12234-Gray  
¼ yd. (22.86cm)

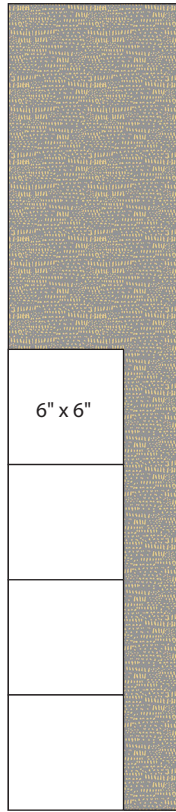

Cut 4 - 6" x 6"  
(15.24cm x 15.24cm)

12235-Yellow  
¼ yd. (22.86cm)

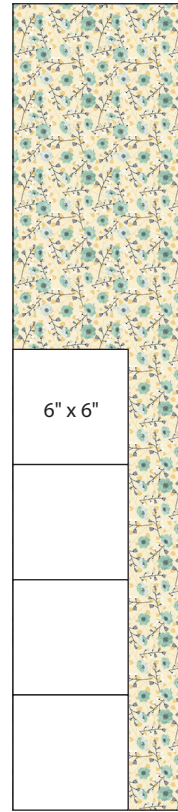

Cut 4 - 6" x 6"  
(15.24cm x 15.24cm)

12240-Gold  
¼ yd. (22.86cm)

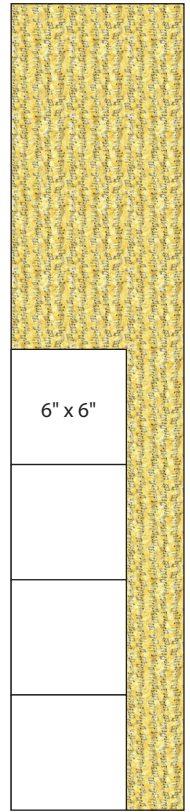

Cut 4 - 6" x 6"  
(15.24cm x 15.24cm)

12237-White  
1 ⅜ yds. (125.73cm)

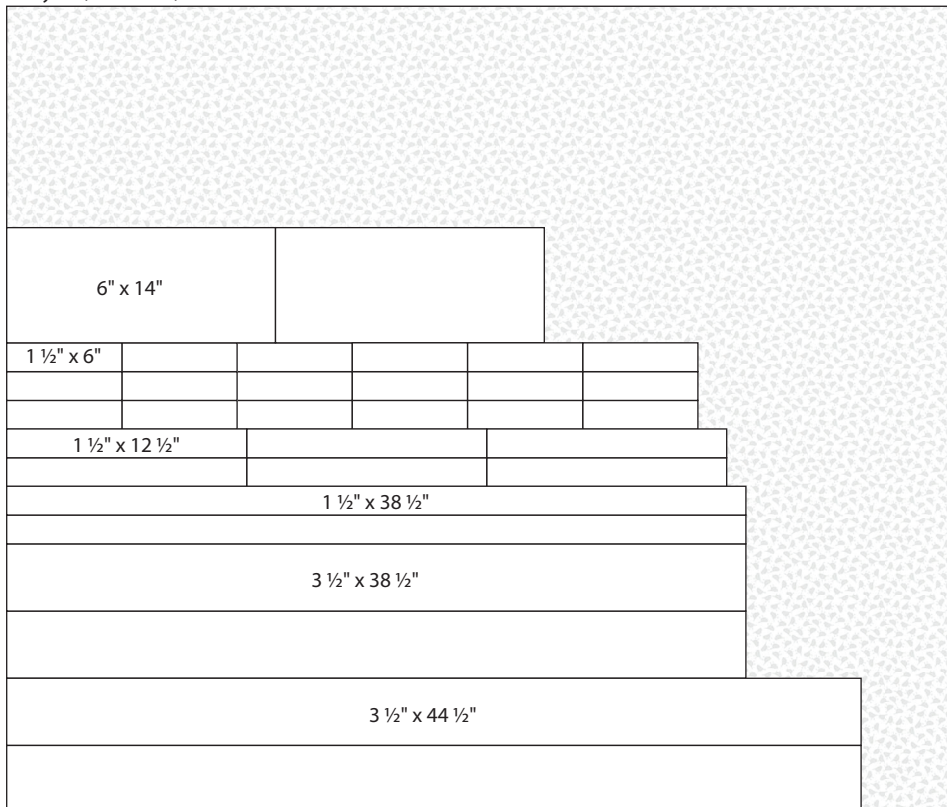

Cut 2 - 3 ½" x 44 ½"  
(8.89cm x 113.03cm)

Cut 2 - 1 ½" x 38 ½"  
(3.81cm x 97.79cm)

Cut 18 - 1 ½" x 6"  
(3.81cm x 15.24cm)

Cut 2 - 3 ½" x 38 ½"  
(8.89cm x 97.79cm)

Cut 6 - 1 ½" x 12 ½"  
(3.81cm x 31.75cm)

Cut 2 - 6" x 14"  
(15.24cm x 35.56cm)

12236-Turq  
 $\frac{3}{8}$  yd. (34.29cm)

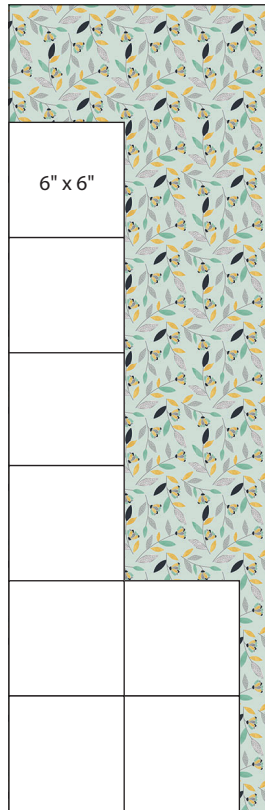

Cut 8 - 6" x 6"  
 (15.24cm x 15.24cm)

12239-Turq  
 $\frac{5}{8}$  yd. (57.15cm)

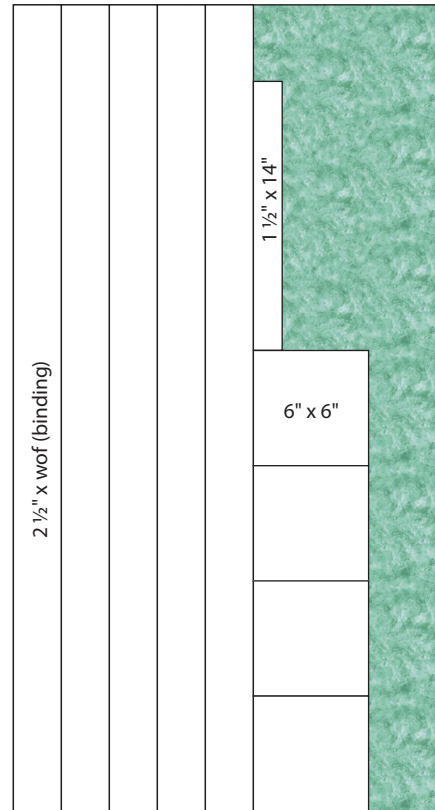

Cut 5 - 2 1/2" x wof  
 (6.35cm x 106.68cm)

Cut 4 - 6" x 6"  
 (15.24cm x 15.24cm)

Cut 1 - 1 1/2" x 14"  
 (3.81cm x 35.56cm)

## Piecing

- Place two 12236-Turq squares (6" x 6", 15.24cm x 15.24cm) on opposite sides of a 12237-White strip (1 1/2" x 6", 3.81cm x 15.24cm). Pin RST, sew and press (Dia. A). The row should measure 6" x 12 1/2" (15.24cm x 31.75cm). Repeat to make a second row.

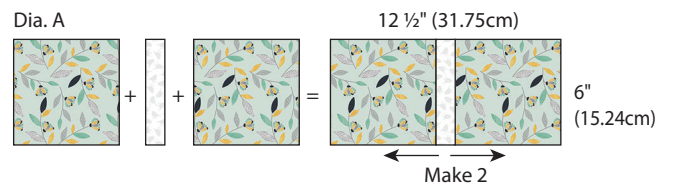

- Place two 12237-White strips (6" x 14", 15.24cm x 35.56cm) on opposite sides of a Turq 12239 strip (1 1/2" x 14", 3.81cm x 35.56cm). Pin RST, sew and press. Cut into nine 1 1/2" x 12 1/2" (3.81cm x 31.75cm) pieces. Place two white strips on opposite sides of the 12236-Turq square; sew and press (Dia. B). The row should measure 1 1/2" x 12 1/2" (3.81cm x 31.75cm).

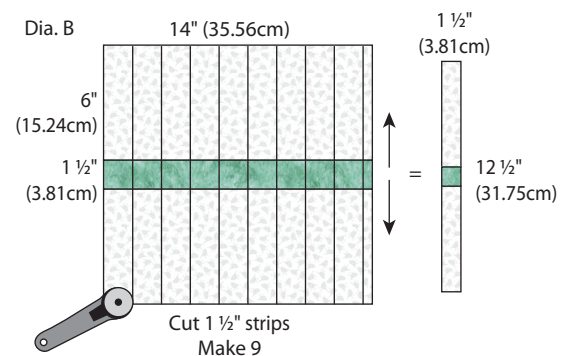

4. Place the rows as shown (Dia. C). Pin, nesting intersecting seams and sew the rows RST to complete the block; press. The block should measure 12 1/2" x 12 1/2" (31.75cm x 31.75cm). Repeat to make a second matching block.

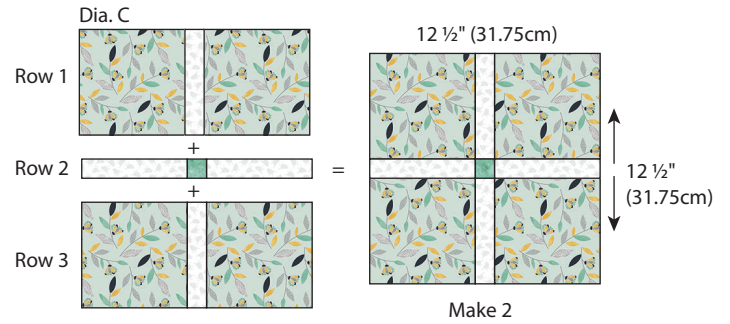

5. Follow Steps 2-4 to make the remaining seven blocks as shown (Dia. D).

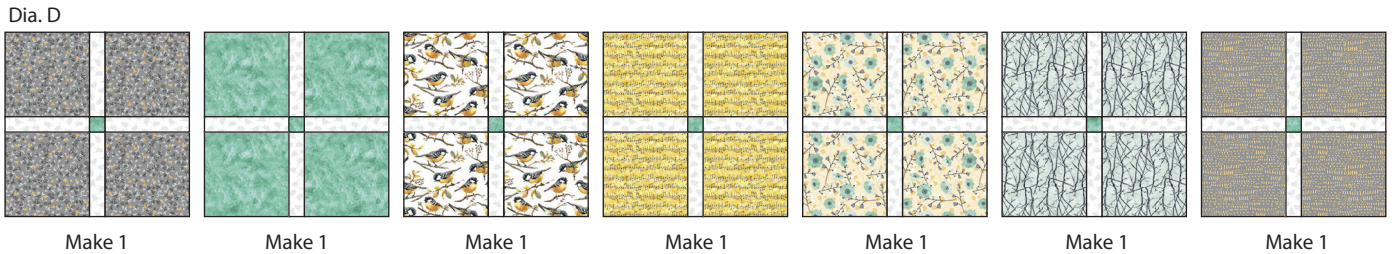

6. Lay out the blocks as shown in three rows of three with the 12237-White vertical sashing (1 1/2" x 12 1/2", 3.81cm x 31.75cm) between the blocks and the horizontal sashing (1 1/2" x 38 1/2", 3.81cm x 97.79cm) between the rows (Dia. E). Pin and sew the blocks and vertical sashing RST by row. Make sure to align the vertical sashing for each row. Each row will measure 12 1/2" x 38 1/2" (31.75cm x 97.79cm). Pin and sew the rows RST with the horizontal sashing. The center unit should measure 38 1/2" x 38 1/2" (97.79cm x 97.79cm). Press seam allowances toward the sashing.

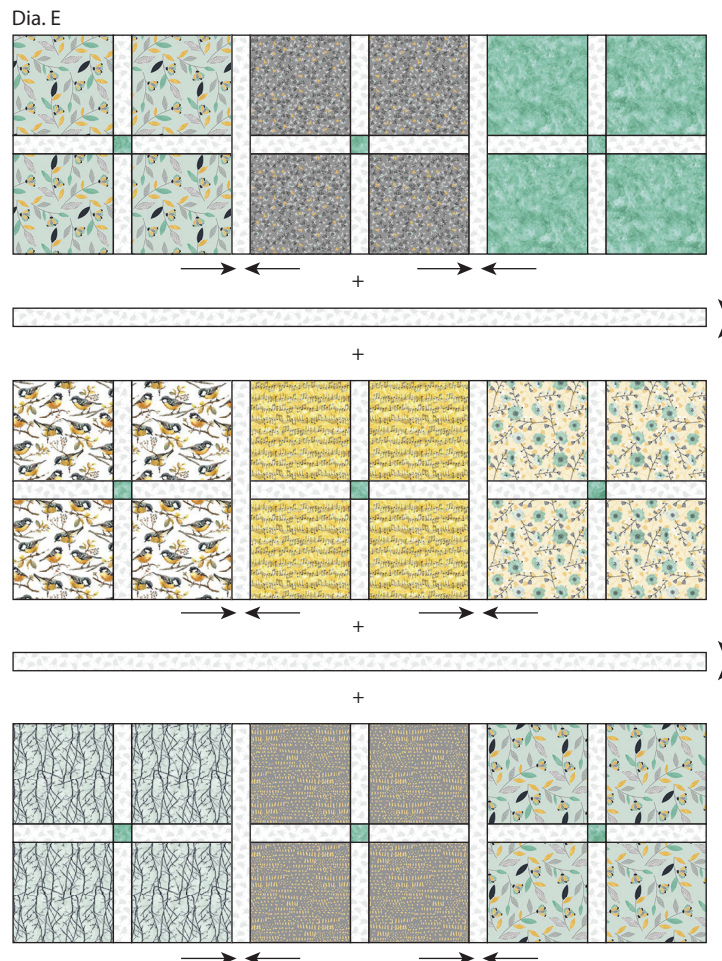



7. Pin the two 12237-White side borders (3 1/2" x 38 1/2", 3.81cm x 97.79cm) RST to the center unit; sew and press. Pin the two White top and bottom borders (3 1/2" x 44 1/2", 3.81cm x 113.03cm) RST; sew and press (Dia. F). The completed quilt top should measure 44 1/2" x 44 1/2" (113.03cm x 113.03cm).

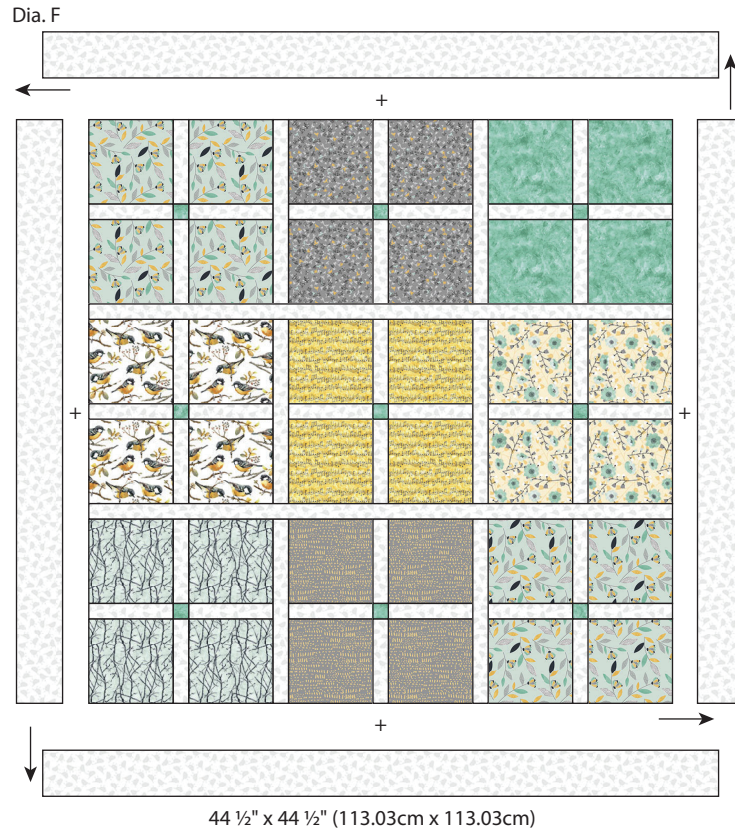

8. To make the backing, remove the selvages and cut three pieces: 50" x 42" (127cm x 106.68cm), 8 1/4" x 42" (20.96cm x 106.68cm), 8 1/4" x 8 1/4" (20.96cm x 20.96cm). Pin and sew the two smaller pieces RST on the short edges, then to the large piece on the long edge to make a backing 50" x 50" (127cm x 127cm) as shown in Diagram G.

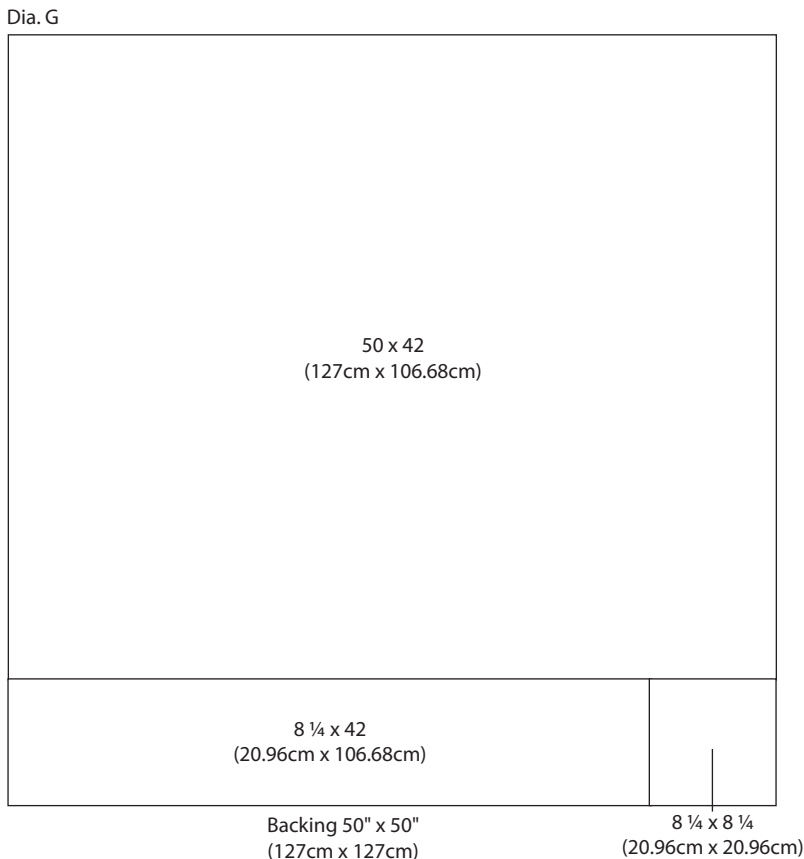

# Quilting

9. Press finished quilt top and backing fabric. Tape the backing, **wrong** side up to a firm surface. Layer batting and quilt top (right side up). Baste the layers together with safety pins. Refer to the quilting diagram for a simple yet creative quilting design. Use masking tape to temporarily mark each line as you sew. Stitch right next to the edge but not through the tape. Remove and re-use in the next row.

Begin in the center and quilt in-the-ditch (or seam) of the center horizontal sashing, then stitch the vertical sashing. Move toward the outside edges of the quilt alternating the stitching direction each time. The parallel lines between the sashing are 2" (5.08cm) away from the sashing and 1" (2.54cm) apart so it creates a woven effect. Quilt two parallel lines 1" (2.54cm) apart in the outer border (Dia. H). **Tip:** Sewing with an even-feed foot is helpful when quilting through layers. This feeds the fabric more evenly and prevents wrinkles on the back of the quilt. Once quilting is complete, square up corners and edges, trimming excess backing and batting even with the quilt top.

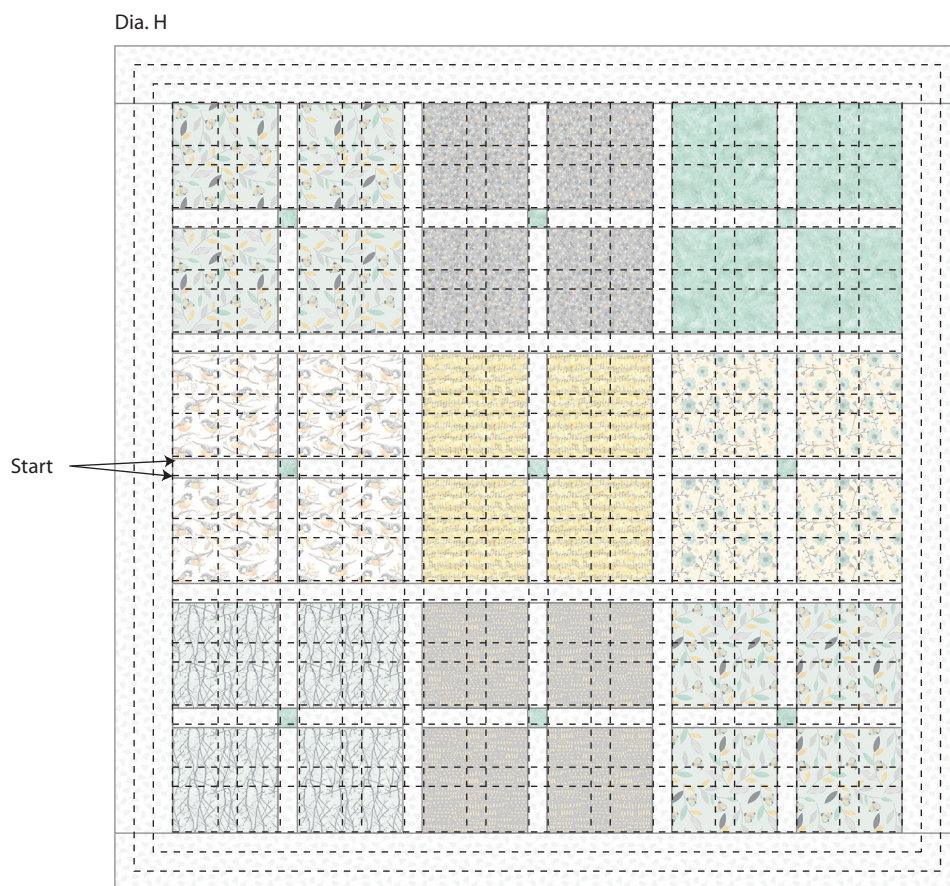

# Finishing

6. To make the binding, remove selvages and sew the short ends of the 2 1/2" x 42" (6.35cm x 106.68cm) strips RST end to end at a 45° angle to make one continuous strip; press seams open. Press one short end 1/4" (6.35mm) to the **wrong** side. Fold in half lengthwise with **wrong** sides together; press. Leaving a 2" (5.08cm) tail on the folded end, place cut edges of folded binding even with the edge of the quilt top and sew, mitering the corners. Overlap ends, trim any excess and finish sewing the binding. Fold binding over to back and hand stitch.

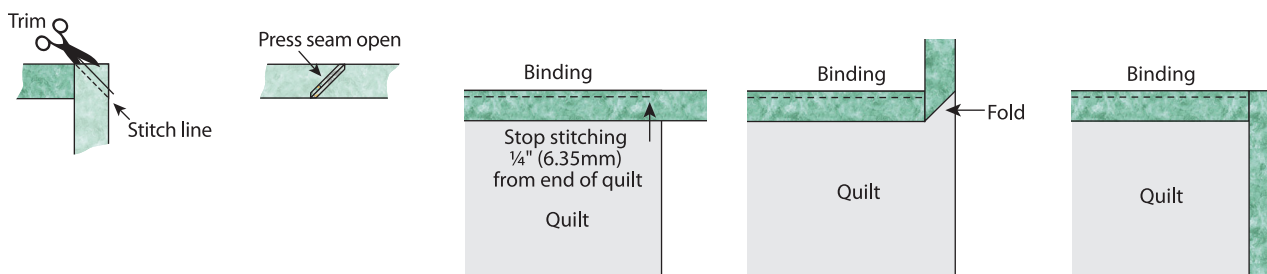

# Finished Care Instructions

Machine wash in cold water; gentle cycle. **Tip:** Before drying, check for fabric dyes that may have run. If fabric dyes run, rewash and rinse using Shout® Color Catcher®. Lay flat to dry or tumble dry low.