

Product Document

Digital Temperature Sensors



About ams



ams is a global leader in the design and manufacture of advanced sensor solutions. Leading manufacturers around the globe rely on ams' sensing know-how for advanced systems design. For ams, "Sensing is Life" and our passion is in creating the sensor solutions that make devices smarter, safer, convenient and more environment-friendly.

ams' sensor solutions are at the heart of the products and technologies that define our world today – from smartphones and mobile devices to smart homes and buildings, industrial automation, medical technology, and connected vehicles.

Our products drive applications requiring small form factor, low power, highest sensitivity and multi-sensor integration. We offer sensors (including optical sensors), interfaces and related software for consumer, communications, industrial, medical, and automotive markets.

Headquarters

ams AG
Tobelbader Strasse 30
8141 Premstaetten, Austria
Phone: +43 3136 500-0
Email: sales-europe@ams.com

Contact us

- sensors@ams.com
- press@ams.com
- sales-europe@ams.com
- sales-asia@ams.com
- sales-america@ams.com

Connect with us

- linkedin.com/company/ams-ag
- youtube.com/user/amsAnalog
- twitter.com/amsAnalog
- facebook.com/amsAnalog

ams.com



We offer our customers more than just a product...

ams' portfolio of digital temperature sensors are the best combination of size, accuracy and current consumption for your design. They meet the highest quality standards to provide you with exceptional reliability over the lifetime of your product.



Benefits

High Accuracy

Can be used to measure human body temperature ($\pm 0.09^{\circ}\text{C}$ accuracy). Precise temperature sensing empowers application possibilities in medical devices

Ultra-Low Power

Newest devices are very power efficient and work below 1.8V for good battery endurance, enabling long term monitoring without disturbance

Space Saving

All members of the device family have a very small form factor and come in WLCSP (1.5 x 1.0 mm)

Alert Functionality

The alarm gets set (and cleared) at user selectable thresholds. No need to constantly poll the temp sensor. It tells you when your set-point is reached.

Multi Device Application

Newest devices in the family support any of eight I²C addresses, therefore a design can have up to 8 of our temperature sensors in it with no I²C bus conflict

Flexibility

Newest devices available with different levels of accuracy depending on what the specific application requires

For more information on our Digital Temperature Sensors, please go to: ams.com/digital-temperature-sensors

Good reasons to choose ams' digital temperature sensors

1. Factory calibrated

Our market success is driven by our in-house expertise. We design and manufacture digital temperature sensors with our customers' needs in mind. The digital temperature sensor is a fully-calibrated and linearized sensor solution that is easy-to-integrate into many designs. No in-house system-level calibration – which can be expensive – is required on the customer side.

2. Compressed bill of materials

The AS62xx family is a complete miniature digital sensor system which means that the accuracy of the design is not dependent on external components such as precision reference resistors or high-grade LDOs and ADCs. In addition, the use of the application processors for temperature conversion is minimized. Customers no longer have to go through the time-consuming exercise of selecting and compatibility testing to find the best components. This allows for a faster time-to-market.

3. Ultra-low power consumption

Our cutting-edge AS62xx family of digital temperature sensors was designed with ultra-low power consumption in mind. In addition to the low operating and standby current consumption, the integrated alarm function with an 'interrupt' pin wakes the application processor only when a threshold has been reached, further reducing the overall power consumption.

Digital Temperature Sensor Portfolio

... takes temperature sensing to the next level

Digital temperature sensors – highly accurate sensing in ultra-small package: body temperature monitoring, long-term medical observation for use cases like Continuous Glucose Monitoring (CGM) systems, stress level monitoring, fitness monitoring, thermostats, smart home appliances, portable devices, cameras, SSD and hard disks, robots & AGVs

Part No.	Accuracy	Output resolution	Supply	Power Consumption	Conversion Time (type)	I2P Addresses*
AS6221	±0.09°C @ 20...42°C ±0.10°C @ -25...55°C	16bit	1.71 - 3.6V @0°C...125°C 2.00 - 3.6V @-40°C...125°C	6µA @ 4Hz 0.1µA(typ) @ standby (25°C)	36ms	8
AS6212	±0.3°C @ -40°C...-10°C ±0.2°C @ -10°C...65°C ±0.3°C @ 65°C...85°C	16bit	1.71 - 3.6V @0°C...125°C 2.00 - 3.6V @-40°C...125°C	6µA @ 4Hz 0.1µA(typ) @ standby (25°C)	36ms	8
AS6214	±1.0°C @ -40°C...0°C ±0.4°C @ 0°C...65°C ±1.0°C @ 65°C...125°C	16bit	1.71 - 3.6V @0°C...125°C 2.00 - 3.6V @-40°C...125°C	6µA @ 4Hz 0.1µA(typ) @ standby (25°C)	36ms	8
AS6218	±1.0°C @ -40°C...0°C ±0.8°C @ 0°C...65°C ±1.0°C @ 65°C...125°C	16bit	1.71 - 3.6V @0°C...125°C 2.00 - 3.6V @-40°C...125°C	6µA @ 4Hz 0.1µA(typ) @ standby (25°C)	36ms	8
AS6200	±0.4°C @ 0°C...65°C ±1°C @ -40°C...125°C	12bit	1.8 - 3.6 V @0°C...125°C 2.0 - 3.6V @-40°C...125°C	6µA @ 4Hz 0.1µA(typ) @standby (up to 65°C)	34ms	2
AS6200C	±0.2°C @ -10°C...20°C ±0.25°C @-20°C...-10°C ±0.4°C @ 20°C...50°C	12bit	1.8 - 3.6 V @0°C...125°C 2.0 - 3.6V @-40°C...125°C	6µA @ 4Hz 0.1µA(typ) @standby (up to 65°C)	34ms	2
AS6204	±0.4°C @ 0°C...65°C	12bit	1.8 - 3.6 V @0°C...125°C 2.0 - 3.6V @-40°C...125°C	6µA @ 4Hz 0.1µA(typ) @standby (up to 65°C)	34ms	4

*... maximum amount of devices on one serial bus

Block Diagram

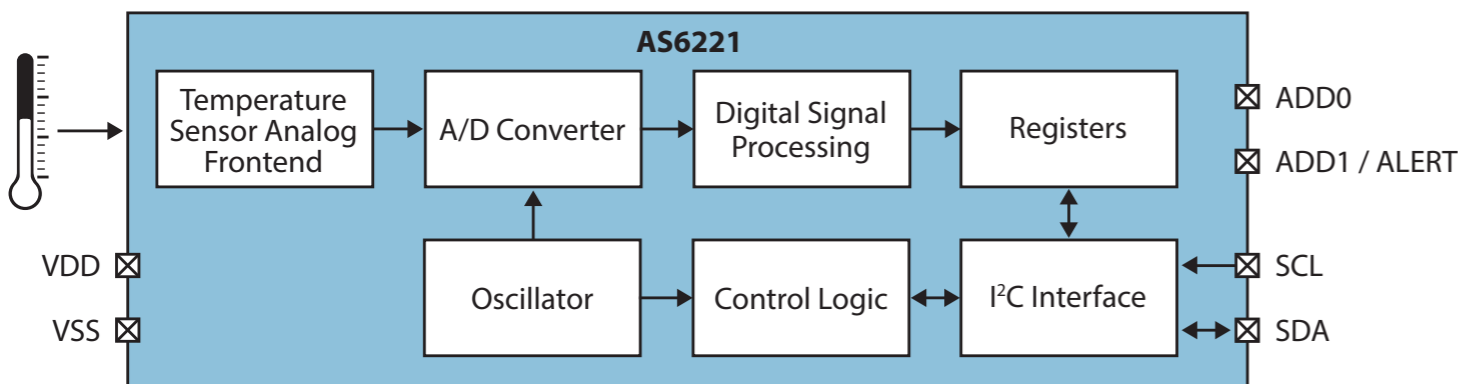

All about...

Highest Accuracy

Precise temperature sensing on body skin empowering customer design to fulfill the standard EN 12470-3 for medical thermometers

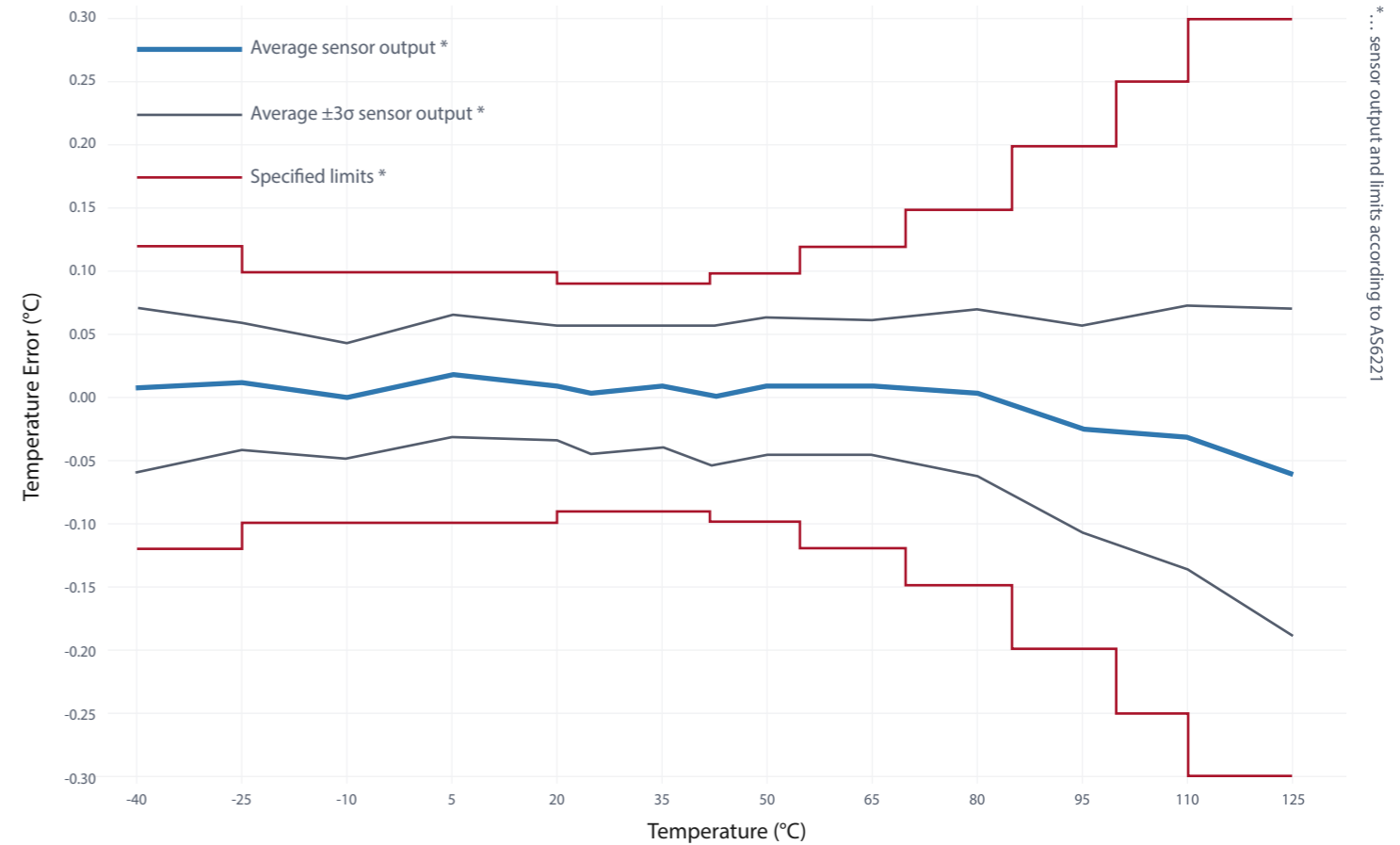

DIGITAL TEMPERATURE SENSOR

AS62XX

HIGH ACCURACY

±0.09°C

SMALL SIZE

WLCSP (1.5mm²)

ALERT FUNCTION

Programmable threshold

WEARABLES

FULLY CALIBRATED

SENSOR OUT vs TEMPERATURE

VOLTAGE RANGE

1.71V to 3.6V

MEDICAL

Applicable for skin temp. measurement

HEALTHCARE

ULTRA-LOW POWER CONSUMPTION

6µA @ 4 samples/sec
0.1µA @ standby

MULTI DEVICE

8 I²C addresses

HVAC