

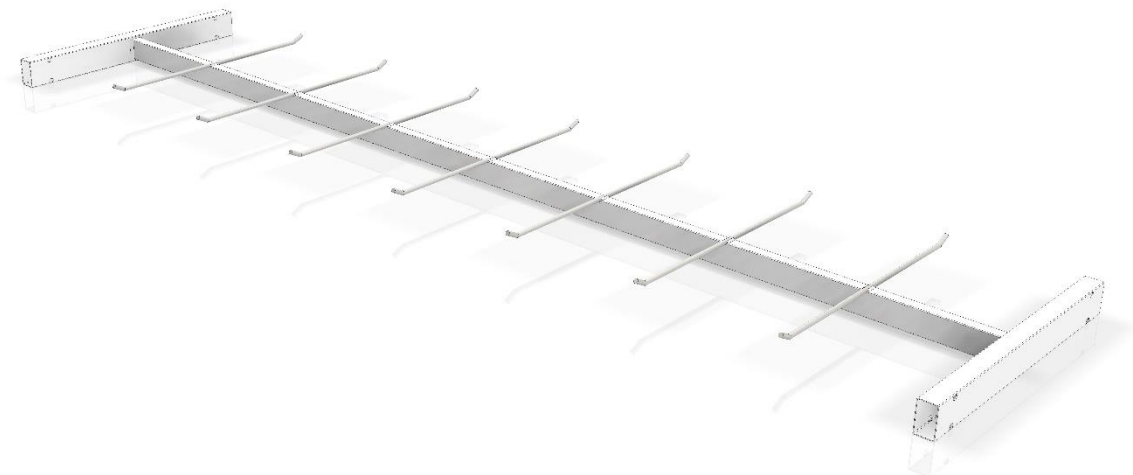





ARCHIVE DRY RACK TEIR INSTALLATION

Complete Instructional Guide





TOOLS NEEDED FOR INSTALLATION

	½" WRENCH or SOCKET
 <p>Mallet</p>	MALLET
	TAPE MEASURE



PARTS LIST
CONFIRM ALL PARTS ARE PRESENT BEFORE STARTING INSTALLATION

	<p>CONTROL ARM HANDLE UNIT</p>
	<p>5/16-18 BOLTS</p>
	<p>5/16-18 NUTS</p>
	<p>FLAT WASHER</p>
	<p>LOCK WASHER</p>

FOLLOW INSTRUCTIONS BELOW

STEP #1

Locate Rack Position.

Locate height you want the Dry Rack off the top of the bottom tray, on all 4 corners.

Note: Marking hole with marker may make it easier to locate when setting rack.

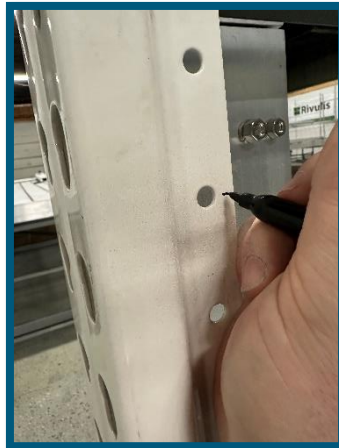

STEP #2

Setting Rack.

With a partner, set dry rack between uprights at the location marked in **STEP #1** making sure slots on rack are aligned with marked holes on uprights.

Slide bolts/pins through the top slots on all 4 corners of rack into upright locating hole to help hold in place until hardware can be installed. *Fig. A*



ARCHIVE DRY RACK INSTALLATION

STEP #3 Installing Hardware

Locate provided 5/16 hardware.

Feed bolt with through outside of first upright on into slot on rack (2) on each corner (8) per rack total.

Note: Do not tighten hardware During this step

Note: fig. B for hardware installation. Also located in Dry Rack – Assembly Details pg. 2 detail A.

When connecting 2 racks onto 1 upright; feed 5/16 hardware through first rack into upright locating holes and then through the following rack.

Note: Do not tighten hardware During this step

Note: Fig. C for hardware installation. Also located in Dry Rack – Assembly Details pg. 2 detail B.

Note: Do not tighten hardware During this step



Note: Mallet may be used in this process to seat hardware in place.

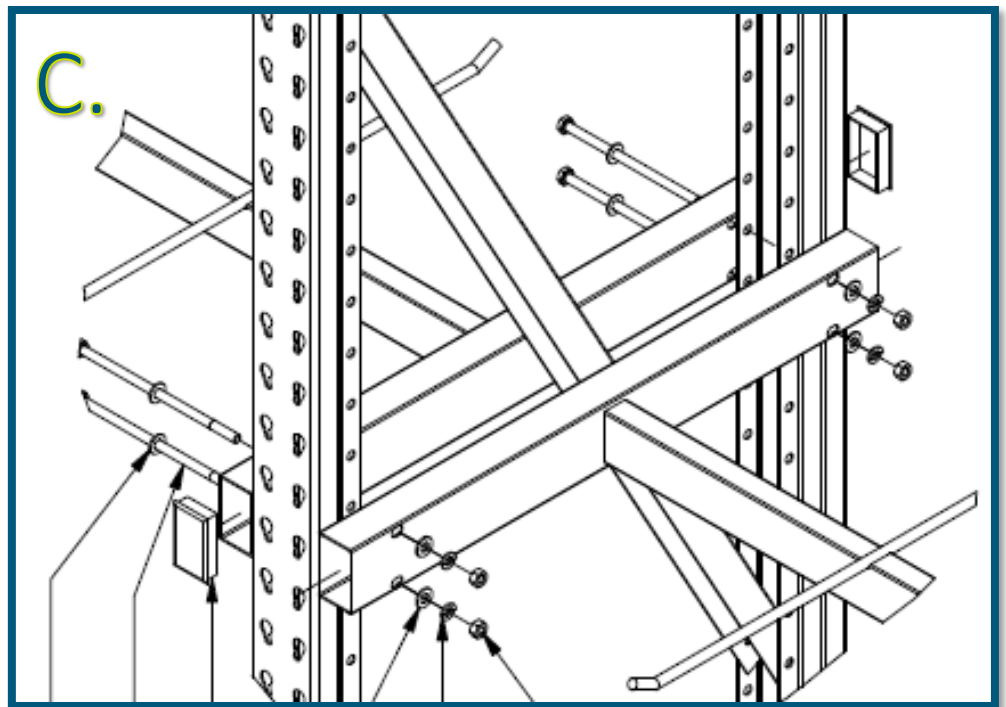
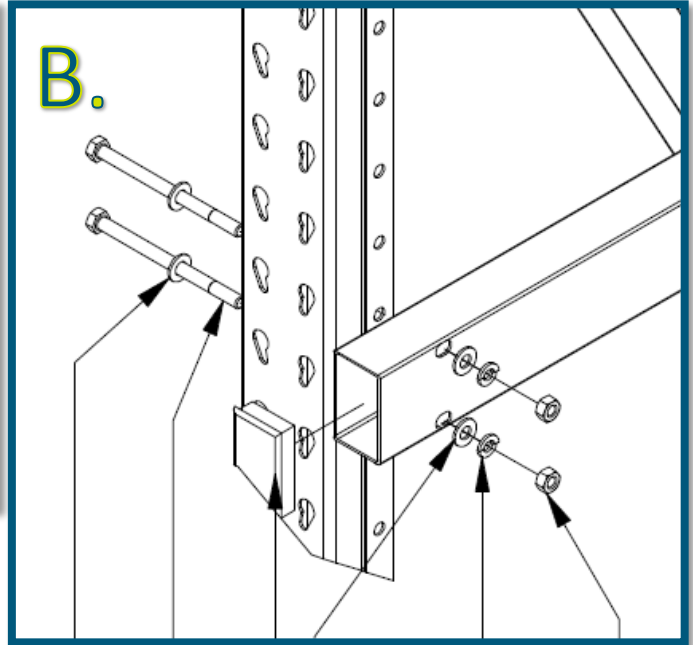

Note: Mallet may be used in this process to seat hardware in place.

STEP #4

Check for level.

Pull a tape measure from bottom step beam to bottom of rack on both sides. Once level is verified, repeat this step for racks above, pulling from top of rack to bottom of rack above.



STEP #5

Tighten Hardware.

Use ½" wrenches or socket to tighten hardware into place. **Do not over tighten!** Nut should be tighten until lock washer sits flat between nut and flat washer. *Fig. D*

Insert tubing plug on all 4 corners of rack by pushing them into the open tube ends. *Fig. E*

Note: Mallet may be used in this process to seat hardware in place.

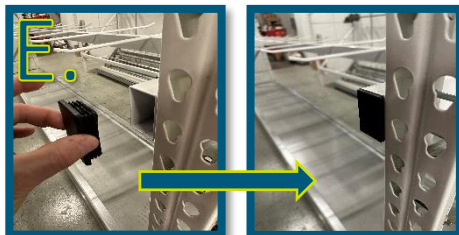
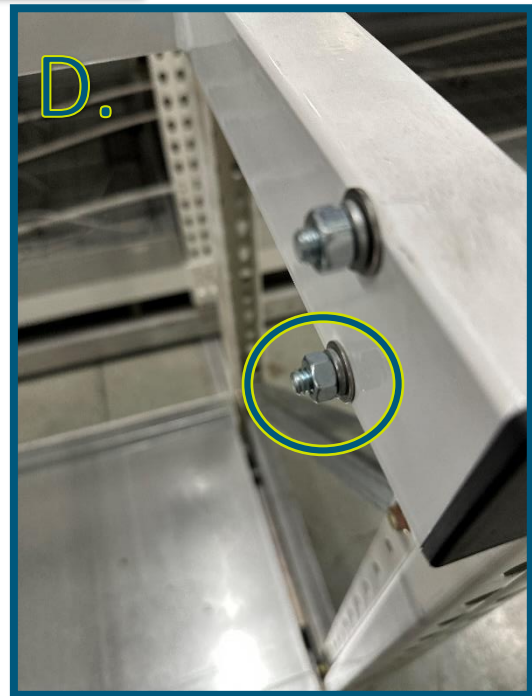



ARCHIVE DRY RACK INSTALLATION

CONGRATULATIONS YOUR ARCHIVE DRY RACKS HAVE BEEN INSTALLED!

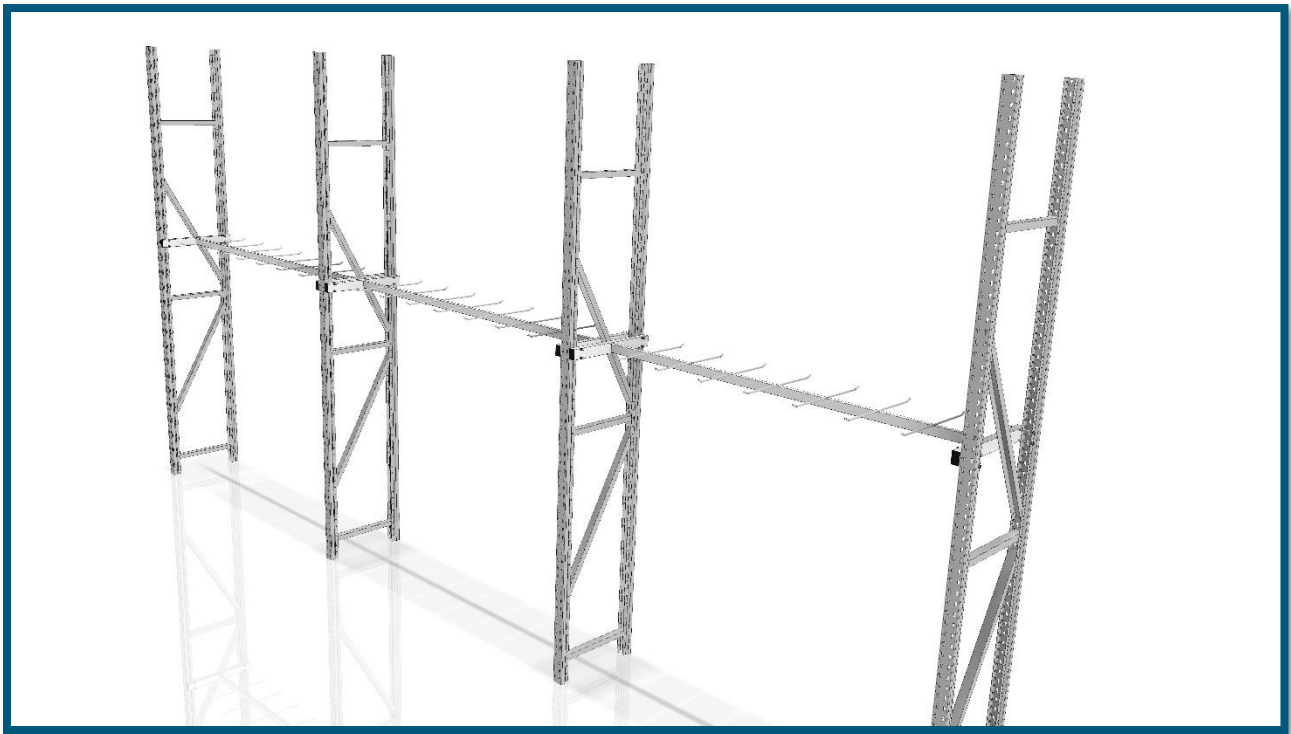

Call 815-991-5010 or email us at sales@innovativegrowersequipment.com if you have any questions

INNOVATIVEGROWERSEQUIPMENT.COM