

TRUCK / SUV

PROCHARGER[®]
SUPERCHARGER SYSTEMS



**PROCHARGER INTERCOOLED SUPERCHARGER SYSTEMS FOR:
CHEVY/GMC, FORD, DODGE/RAM,
JEEP AND TOYOTA**

**"ProCharger is the world headquarters
of supercharging." – Bret Kepner**



INVENTED, ENGINEERED



AND MADE IN THE USA



TRUCK/SUV/OFF-ROAD

TABLE OF CONTENTS

ProCharger Advantages	4-11
2019-2023 GM Truck/SUV (6.2L, 5.3L)	12
2020-2023 GM Truck 2500 (6.6L)	13
2015-2019 GM Truck 2500 (6.0L)	14
2014-2020 GM Truck 1500 (6.2L, 5.3L)	15
2007-2014 GM Truck/SUV (6.2L, 6.0L, 5.3L, 4.8L)	16
2003-2007 GM Truck/SUV (6.0L, 5.3L, 4.8L)	17
1999-2003 GM Truck/SUV (6.0L, 5.3L, 4.8L)	18
1988-2000 GM Truck/SUV (7.4L, 5.7L)	19
2003-2009 Hummer H2 (6.2L, 6.0L)	19
2021-2023 Ford F-150 (5.0L)	20
2020-2023 Ford F-250/350 (7.3L)	21
2018-2020 Ford F-150 (5.0L)	22
2015-2017 Ford F-150 (5.0L)	23
2011-2014 Ford F-150 (5.0L)	24
2010-2014 Ford F-150 & SVT Raptor (6.2L, 5.4L)	25
2004-2010 Ford F-150 (5.4L)	26
1997-2003 Ford F-150 & Expedition (5.4L, 4.6L)	27
2019-2023 HEMI Ram (5.7L, 5.7L eTorque)	28
2009-2023 HEMI Ram Classic (5.7L)	29
2014-2023 HEMI Ram 2500 (6.4L)	30
2004-2008 HEMI Ram (5.7L)	31
1996-2001 Ram/Dakota/Durango (5.9L, 5.2L)	32
2018-2023 Durango SRT (6.4L)	33
2020-2023 Jeep Gladiator JT (3.6L)	34
2018-2023 Jeep Wrangler JL (3.6L)	35
2012-2018 Jeep Wrangler JK (3.6L)	36
2012-2020 Jeep Grand Cherokee SRT (6.4L)	37
2011-2020 Jeep Grand Cherokee (5.7L)	38
2006-2010 Jeep Grand Cherokee SRT8 (6.1L)	39
2016-2023 Toyota Tacoma (3.5L)	40
2005-2015 Toyota Tacoma (4.0L)	41
2010-2022 Toyota 4Runner (4.0L)	42
Off-Road / Racing / F-series	43-45
Centrifugal Supercharging	46-56
Show, Go, & Tow; Media Highlights	58-59
Proven History: Timeline of Power	60-61
ProCharge Your Life	63

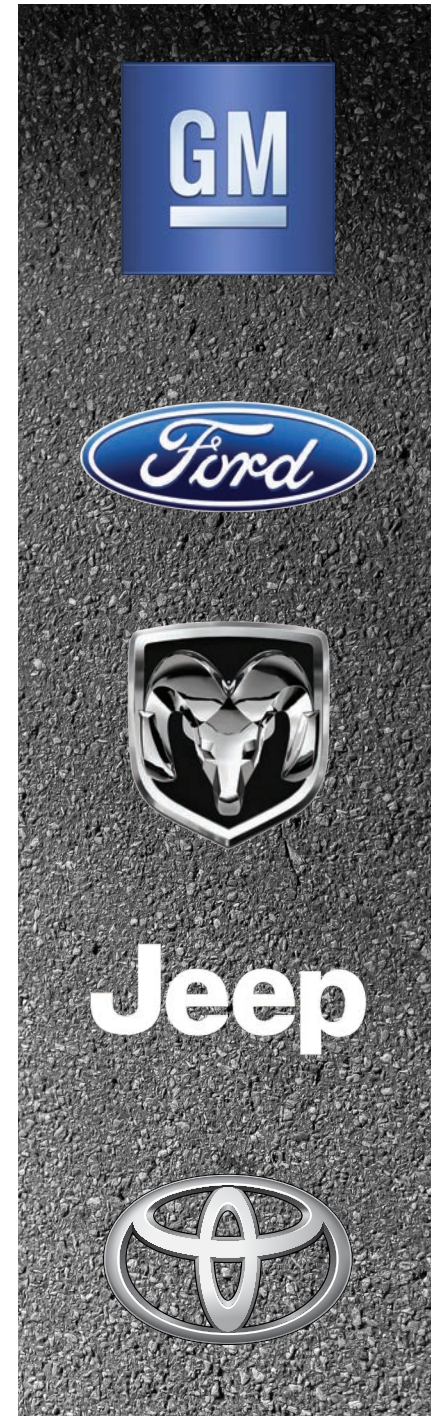

A LEGACY BUILT ON POWER

LARGEST POWER GAINS, COOLEST CHARGE AIR TEMPERATURES & GREATEST RELIABILITY

Proven ProCharger Systems

ProCharger was the first to offer intercooled supercharger systems for trucks and SUV's, nearly 5 years before others. With industry leading experience and technology, ProCharger produces the coolest charge air temperatures and largest power gains. From the dyno to the street, on and off road, ProCharger's engineering and R&D teams go to great lengths to ensure your supercharged and intercooled American-made truck/SUV is everything you expect and more.

Powerful, Efficient and Reliable

A ProCharger Intercooled Supercharger System can add 50 to 75% more power to your truck or SUV with no additional engine modifications, special fuels, or need for extended cool down times.

Sustainable Torque

Thanks to the coolest charge air temperatures and no exhaust interface, ProCharger systems also produce the lowest exhaust gas temperatures in the industry. With this thermal advantage, ProCharger is not only able to produce a large increase in torque, but more importantly, sustain that increase substantially longer than other power adders. What does this mean to you? ProCharger gives you power and torque when it matters most without sacrificing engine longevity.

Easy to Own - Easy to Drive

With millions of boost-enhanced miles under their tires, ProCharger owners enjoy the best of both worlds: everyday reliability and driveability with incredible power that is just a toe-tip away. ProCharger systems and kits are designed to be installed on completely stock or modified engines, and thanks to no major modifications, your truck/SUV can be returned to stock condition.



“...Over the past 30 years, improvements to supercharger kits in general can in large part be attributed to ProCharger, resetting the performance...bar higher for everyone. This isn't hype, but a matter of historical record.” -

MOTORTREND



OEM Appearance & Quality

When it comes to the finished installation, a ProCharger system for your truck/SUV features an outstanding “from the factory” look. A clean, professional and neatly integrated finished product means this is a supercharger system that you will be proud to show off every chance you get.

Coollest Charge Air Temperatures

ProCharger Supercharger Systems feature high efficiency compressors and ultra-effective air-to-air intercoolers to provide the coolest charge air temperatures available. Thanks to this technology, intercooled centrifugal supercharging has proven to be the most engine-friendly and easily installed type of forced air induction. This gives you peace of mind from the most respected name in supercharging.

System Options and Choices

In addition to having the broadest product offering as compared to other forced induction systems, ProCharger is also the only company that offers you the most options to customize the supercharger system to your needs. Noise level (standard or a more stealthy helical option), finish (satin, black, or polished) on most superchargers and brackets, and a supercharger upgrade superior to other brands are just a few of our possible customizations.

The Ultimate Power Adder®

Powerful, purposeful, and individualized—hallmarks of so many trucks and truck owners, as well as the industry-leading intercooled supercharger systems from ProCharger. Over the past 30 years, a multitude of independent third party tests have documented the superiority of intercooled ProCharger systems. Once you've experienced the incredible, real-world performance of this technology, you'll agree that ProCharger is the Ultimate Power Adder™.

THE ULTIMATE POWER ADDER®

EXTREME DURABILITY, FUEL-MILEAGE FRIENDLY

Unmatched Quality & Proven Durability

For 30 years, ProCharger has designed and manufactured its own superchargers and complete systems (unlike some competitors who buy head units and components elsewhere and are really only assembling kits). This helps to ensure that ProCharger delivers a high-quality, high-performance product designed specifically for your needs. In-house design and production capabilities allow ProCharger to provide industry-best warranty protection, with a 3-year extended warranty available for superchargers.

"This P1SC Pro-Charger has 230,000 miles on it and has never had one single problem. This says a lot about the product ProCharger makes." - Dan D.

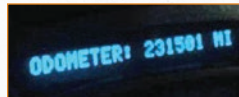

100% Complete Systems

ProCharger Supercharger Systems are 100% complete—nothing else to purchase. ProCharger's intercooled supercharger systems come with all the components needed for an attractive, OEM-quality installation. Install it yourself or have your ProCharger dealer install it for you. The choice is yours.

Resources, Experience and Service Excellence

All ProCharger Supercharger Systems are engineered in-house and then dyno and field-tested by a dedicated team of engineers and technicians on the industry's largest fleet of R&D test vehicles. This diligence results in the most advanced, engine-safe and durable supercharger systems on the market. With 30 years of performance leadership, world-class engineering and manufacturing, and the best technical and customer service teams in the industry, the choice is clear: ProCharger.

Strongest Dealer Network

ProCharger has the largest network of independent dealers across North America and around the world that specialize in installing and fine-tuning your supercharger system. Just like the supercharger systems they install, ProCharger dealers are the best in the business when it comes to helping you realize your performance goals and aspirations.

Fuel Mileage Friendly

Beyond industry-leading power, centrifugal forced induction is also the most fuel efficient form of high performance, with owners frequently reporting improved fuel economy under normal operating conditions, as well as outstanding durability.

"Before the supercharger I would get 13.5 in town and 15.8 on the Hwy. I reset it and as I get up to speed I see it go to around 18 MPG ... As I continued to drive it just kept going up [to 20.9 MPG, highway driving]. My truck has 3.73 gears and 33.5s on 18x9s." - Bill L.



Hunter M. reports that his GMC Sierra with 125,000 miles went from 10/18 mpg to 11 mpg city and 22 mpg highway, despite his "heavy foot" and 500 RWHP.

"The ProCharger helped more than compensate for the oversized tires on my 4WD Ram, and fuel economy is virtually unchanged." - Beverly P.

"Couldn't have been happier with that truck [5.0L F-150] ... Best mpg to date is 25.9! Thanks again for all of your help!" -Neil M.

"I knew the performance increase would be extremely impressive, but was surprised by the 2-3 mpg increase in fuel economy with my Hummer H2." - Bill R.



ProCharger's own 5.4L F-150 is used for extended towing duties to national events, and regularly records 22 mpg on the highway when not towing, and 13 mpg when towing a heavily loaded 18 foot enclosed trailer.

"I have an 5.3L Tahoe and my P-1SC has approx. 100,000 miles on it. I get about a mile per gallon more than I did before the supercharger. My uncle has a 6.0L Denali with a D-1SC and he pulls an 11,000 lb travel trailer with his. He has about 140,000 miles on his supercharger and loves it also." -Jason S.

“...they also get easy driveability and great gas mileage, because if it’s tuned right, a supercharger will give you 20 to 25 percent better fuel economy.”

–Performance Racing Industry Magazine



Visit ProCharger.com for the latest video, blog updates and additional information



COOLER IS BETTER

TECHNOLOGY ADVANTAGE

“Because of the extraordinary efficiency of both the ProCharger and intercooler, intercooled ProCharger systems feature the coolest intake temperatures” – *Sport Truck*

Air-to-Air Intercooled Supercharging

ProCharger pioneered the practice of intercooling as an integral design solution for aftermarket supercharger systems years before others, and to this day still offers the most effective, reliable and highest flowing intercoolers. ProCharger intercooler systems have been specifically designed to deliver the lowest charge air temperatures to the engine for maximum engine longevity and efficiency with zero maintenance. In test after test, ProCharger’s air-to-air intercooled supercharger systems have been proven to produce the largest power gains and coolest charge air temperatures.

Benefits Of Air-to-Air Technology vs Air-to-Water-to-Air

Air-to-air intercooling provides cooler charge air and is inherently more effective than air-to-water products. In fact, with its relatively complex “two step” cooling process involving a secondary heat exchanger, air-to-water intercooling is more accurately described as “air-to-water-to-air” (see page 46 for details). Air-to-air intercooling, on the other hand, is simple and 100% reliable. With not only greater cooling and easier installation, but also zero worries of a coolant pump failure, coolant leaks or maintenance. Failure of an air-to-water-to-air intercooler can result in serious and expensive engine damage due to detonation or water entering the engine.

“When space permits an **adequately sized air-to-air intercooler** to be fitted and given access to decent airflow, it **will always prove superior**. The only excuse for a liquid-based intercooler is when severe space restrictions exist [including positive displacement superchargers, due to mounting location] or... where an iced coolant can be used.” – *“SuperCharged”, Corky Bell*

Thermal Advantages

The cooler air from air-to-air technology delivers a more dense fuel air charge for additional power, while also reducing exposure to detonation and engine damage. Similar advantages are also derived from greater compressor efficiency and an advantaged mounting location, when comparing centrifugals to positive displacement designs. ProChargers utilize natural centrifugal forces to compress the air, resulting in efficiencies superior to positive displacement roots and screw superchargers. Furthermore, ProCharger’s supercharger and intercooler mounting locations are also advantaged from a thermal perspective. Positive displacement blowers, mounted on top of the engine, are directly exposed to heat transfer from the engine and act as a heat sink. Turbos are exposed to even greater heat from their exhaust interface. See pages 50-51 and ProCharger.com for more information.



Visible light image of intercooler

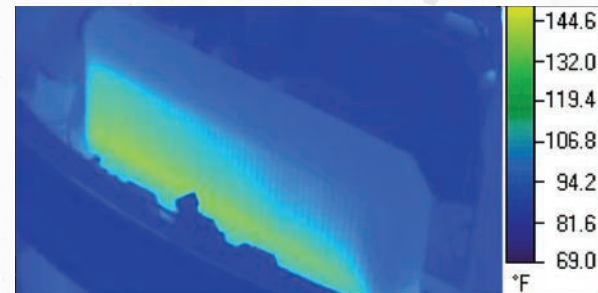

Thermal image of above intercooler

“Any time that you compress air, like with a supercharger, that creates heat, and heat is the enemy of horsepower. An air-to-air intercooler takes that hot blast of air and cools it down. This [Intercooled ProCharger system] will give you a **65% increase in power**. That’s more than any other supercharger on the market.” – *“Trucks!” TV*

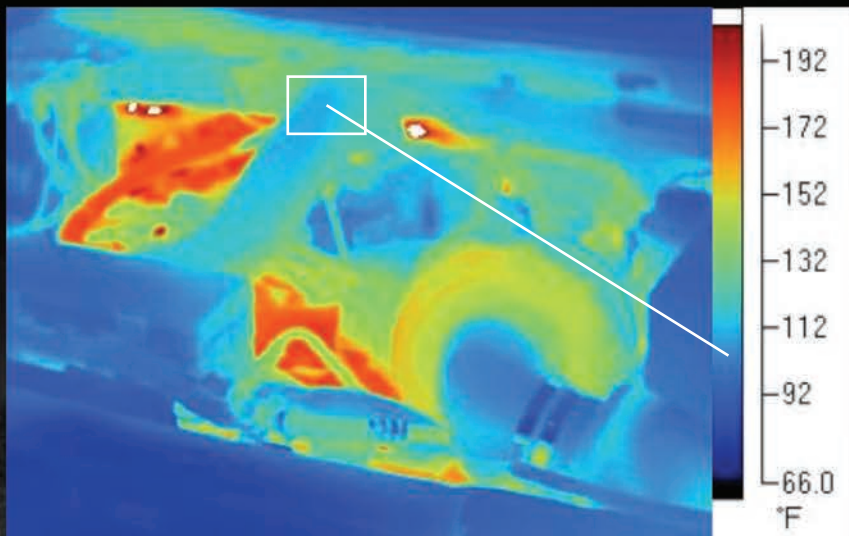

Intercooled ProCharger, 8 psi

Ease of Installation

ProCharger’s supercharger mounting location provides a quick, simple installation, with no engine disassembly, unlike positive displacement blowers. The simplicity of air-to-air intercooling, especially with the space available in truck engine compartments, further simplifies installation. Typical installation time for complete ProCharger systems for trucks and SUV’s is approximately 6-8 hours, vs 10-12 hours for intercooled positive displacement, and 12-20 hours for intercooled turbo kits.

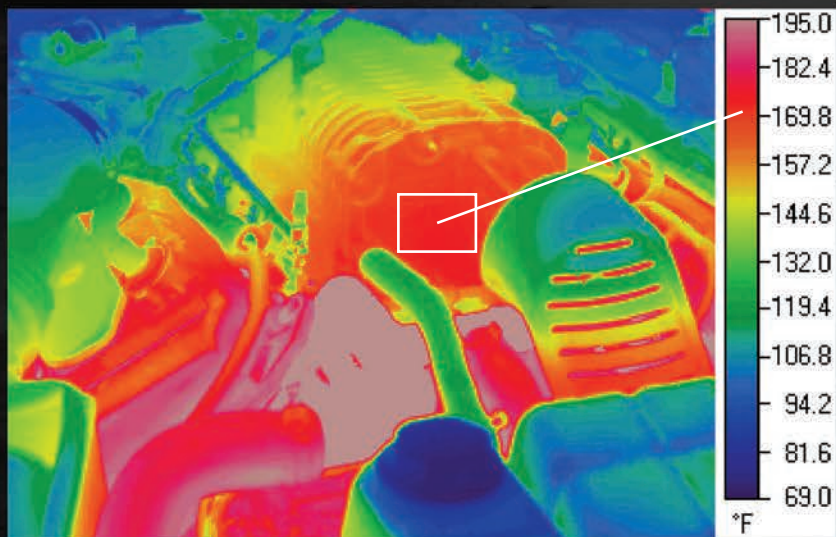

Positive displacement w/ air-to-water-to-air intercooler, 8 psi

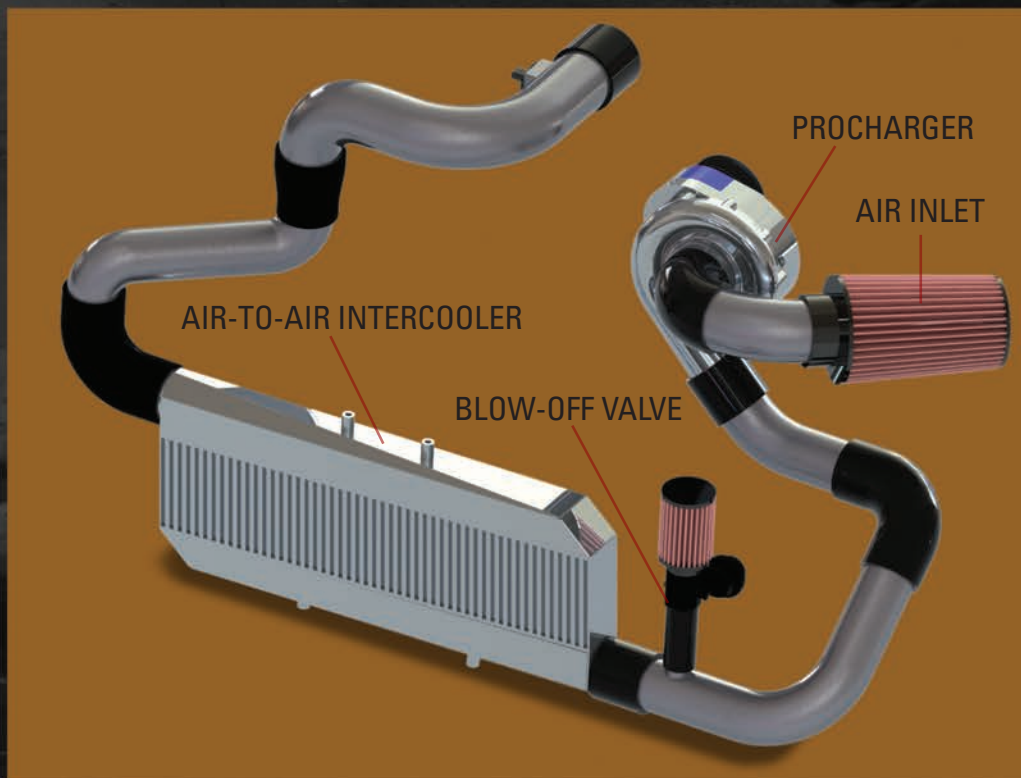

CENTRIFUGAL LEADERSHIP

DESIGNED TO BLOW AWAY THE COMPETITION™

Supercharger Technology

ProCharger introduced the industry's first self-contained, gear-driven supercharger in 2000. Since then, this patented and proven self-contained design has become the standard by which other superchargers are measured.

The top-selling ProCharger P-1SC, P-1SC-1, P-1X, D-1SC and D-1X supercharger models share many of the design elements that deliver the record-setting durability and performance of the ProCharger F-Series competition superchargers. With their rugged design, including an exclusive billet gear case, these self-contained superchargers are powerful and efficient enough to harness the benefits of air-to-air intercooling, while also being durable enough to carry the industry's best warranty coverage.

The patented self-contained design eliminates the need for an external oil supply or oil lines that require a hole to be punched in the engine's oil pan. Additionally, testing has shown self-contained superchargers run cooler than those fed by engine oil.

Internal Oiling System

At the heart of the ProCharger self-contained design is a simple, but highly effective oil aerator. This oil aerator creates the oil mist lubrication required for the precision bearings and gears. This design does not require priming at start-up, and oil changes are only required every 6,000 miles.

Instead of being forced to utilize hot engine oil or the grease in sealed bearings, ProCharger superchargers are lubricated with an extremely high-quality synthetic oil specifically engineered for high speed use.

ProCharger's self-contained design eliminates the heat that is transferred to a supercharger by engine-oiled designs and also avoids the possibility of supercharger damage that can result from clogged oil feed lines or oil drainage problems.

Billet Impellers

Using state-of-the-art, five-axis CNC machines, ProCharger's proprietary impeller designs are crafted from aircraft-grade 7075 T-6 aluminum alloy for tremendous strength and performance. This top-tier material allows for larger impellers that weigh less and are free of the flaws found in typical cast impellers. Large, structurally sound impellers can produce higher pressure, flow more air and in turn, produce more power.

"ProCharger has really taken supercharging to the next level"

– Chevy High Performance

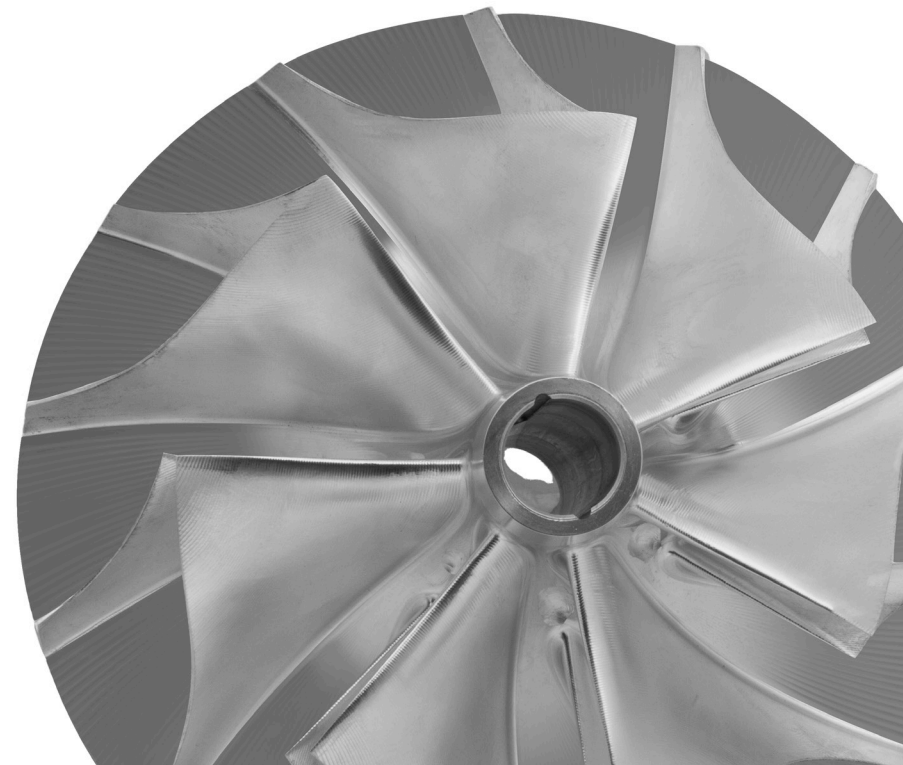

Self-Contained Superiority

ProCharger self-contained superchargers were designed specifically to be self-lubricating, not as an afterthought. Not only does this make our superchargers easier to install, but this patented, gear-driven, self-contained design is durable enough to be available with the best warranty in the industry.

Industry leading 4.10:1 step up ratio

Precision ground gears provide unmatched durability

Exclusive 7075 T-6 billet impeller

Custom Teflon composite high pressure dual lipped seal

Precision high speed rated aerospace spec support bearings

Patented aeration system provides self-contained oiling with superior bearing lubrication

Exclusive CNC machined 6061 billet aluminum housing ensures precise shaft alignment

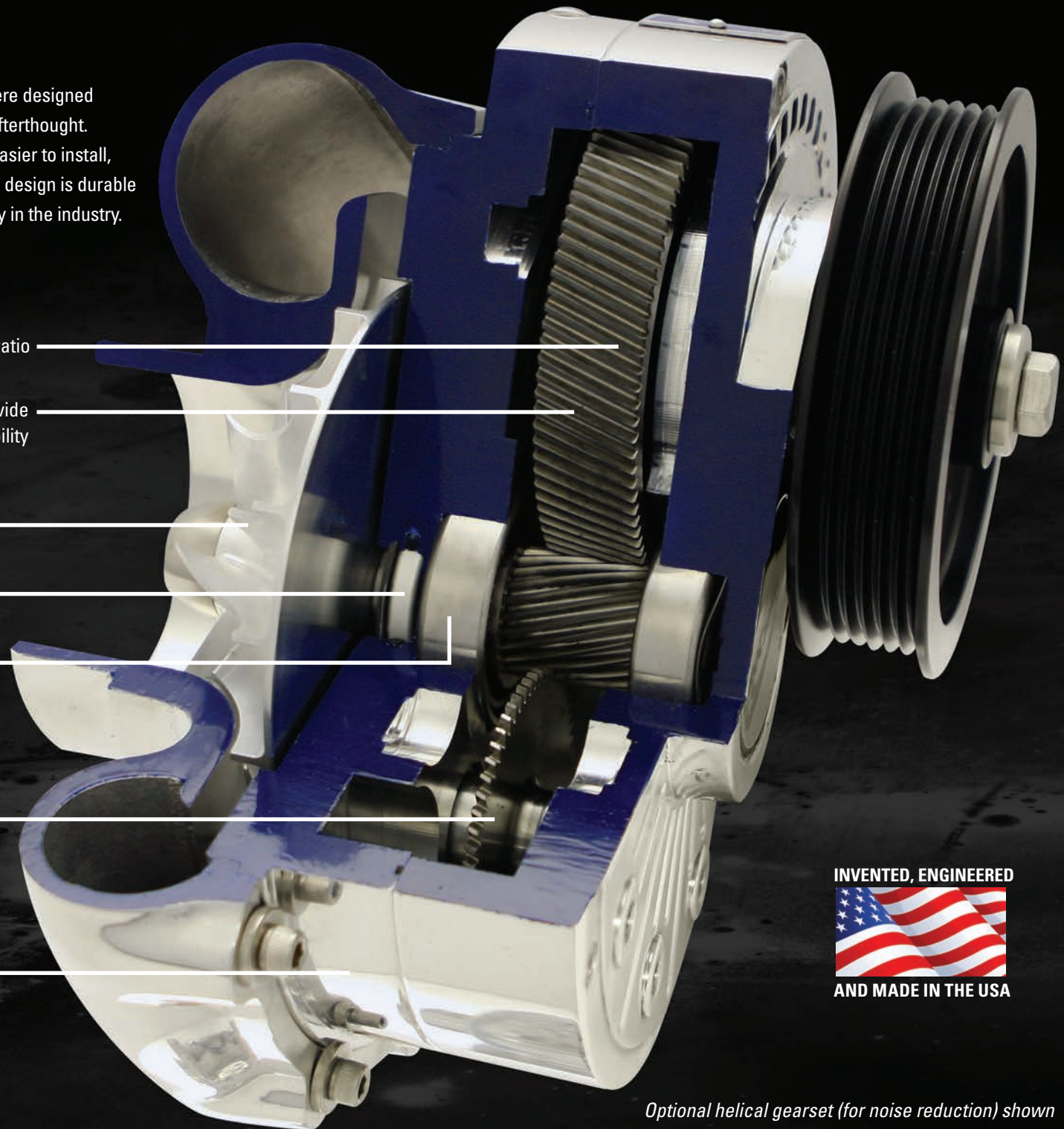

INVENTED, ENGINEERED

AND MADE IN THE USA

Optional helical gearset (for noise reduction) shown



2019-2023 • 1500
2021-2023 • SUV
6.2L, 5.3L



2019-2023 GM Truck/SUV's

Boosting your 2019-2023 Chevy or GMC 1500/SUV to 609+ horsepower has never been easier, thanks to this easy-to-install ProCharger supercharger system. The 45%+ power gains means LOADS of extra power to pull, pass, or pay, without sacrificing drivability or fuel economy. These systems produce a massive torque curve through the mid to upper power band, matching the shift points of these transmissions perfectly. All kits and systems (8 psi) include a highly effective air-to-air intercooler producing the coolest air charge temps possible, while also having no moving parts to fail. These features are what have led to our customers commonly reporting 200k+ miles being placed on ProCharged GM trucks. No matter if you are looking for the extra power for your daily driver, work horse, or track toy, adding a ProCharger ensures years and years of supercharged performance out of your engine.

HO Intercooled System

- The Industry's coolest charge air temperatures and largest power gains
- ProCharger P-1SC-1, 3-year warranty available
- ProCharger's self-contained oiling design requires no external oil lines
- Large 3-core air-to-air intercooler is standard, 3-year standard warranty
- Bullet blow-off valve
- System is 100% complete with OEM appearance and quality
- Dedicated 8-rib belt drive (standard)

Stage II Intercooled System

- Larger Stage II intercooler
- High-flow inlet and filter
- Otherwise includes all HO items listed above

HO / Stage II Intercooled Tuner Kits

- Omits tuning, otherwise identical to systems

Optional Upgrades Include:

- Black or Polished finish for supercharger and/or bracket
- Helical gearset for noise reduction (P-1SC-1, P-1X, D-1SC, D-1X)
- ProCharger P-1X, D-1SC, D-1X, F-1A and F-1A-94 supercharger upgrade



**2019-2023 GM Truck/SUV's
 Systems & Tuner Kits Available for:**

- Chevrolet Silverado
- Chevrolet Tahoe
- GMC Yukon
- GMC Sierra
- Cadillac Escalade
- Chevrolet Suburban

"Instant power capable of roasting the hides at any minute!"
-Truck Trend



2020-2023
2500 HD 6.6L



2020-2023 Chevy and GMC 2500 HD

Take your 2500 HD to the next level! Delivering 6 psi of boost that translates to a remarkable 50-55% horsepower gain (6 psi) on otherwise stock engines. The HO Intercooled System comes complete with preformed tubing, an upgraded fuel system, and user-friendly step-by-step instructions. And the icing on the cake? Our massive 3-core vertical air-to-air intercooler. Keeping things cool in your engine bay without sacrificing performance.

Designed for precision, the system incorporates a dedicated belt design for the self-contained P-1SC-1 supercharger. Plus, you get the flexibility to opt for our helical gears set option, which guarantees lower supercharger noise levels for those seeking a refined driving experience. But the real game-changer is our patented self-contained supercharger oiling design. Say goodbye to external oil lines or the need to tap into your truck's engine oil supply.

HO Intercooled System

- The industry's coolest charge air temperatures and largest power gains
- ProCharger's proven and patented, self-contained oiling design—no external oil lines
- Large 3-core air-to-air intercooler is standard
- 1-year supercharger warranty is standard, with optional 3-year warranty available
- System is 100% complete with OEM quality and appearance
- Dedicated 6-rib belt drive

HO Intercooled Tuner Kits

- Omits tuning
- Otherwise identical to HO Intercooled System

Optional Upgrades Include:

- Black or Polished finish for supercharger and/or bracket
- Helical gears set for noise reduction (P-1SC-1, P-1X, D-1SC, D-1X)
- ProCharger P-1X, D-1SC, and D-1X series supercharger upgrade



"The truck had a completely new driving personality, and the slight but distinctive supercharger whine sounds awesome" - MotorTrend



2015-2019 2500 HD 6.0L



2015-2019 Chevy and GMC 2500

Delivering 6 psi of boost representing a 45% horsepower gain on otherwise stock engines, ProCharger's 2015-2019 GM 6.0 Truck systems produce a substantial difference in everyday drivability and towing. The HO Intercooled System includes preformed tubing, step-by-step instructions, as well as a one-year standard warranty that the owner can extend to a full 3-years for a stock vehicle. The system also features a shared-drive design for the self-contained P-1SC-1 supercharger and comes with a 3-core vertical intercooler. Additionally, a choice of the helical gerset option for lower supercharger noise levels is available. The brackets and superchargers have three different finish options: satin, polished, or black. Lastly, ProCharger's patented and proven self-contained supercharger oiling design eliminates the need for external oil lines or the need to tap into the engine's oil supply. This simplifies the installation while also providing superior lubrication and lower supercharger oil temperatures.

HO Intercooled System

- The Industry's coolest charge air temperatures and largest power gains
- ProCharger's proven and patented, self-contained oiling design-no external oil lines
- Large 3-core air-to-air intercooler is standard
- 1-year supercharger warranty is standard, with optional 3-year warranty available
- System is 100% complete with OEM quality and appearance
- Shared 6-rib belt drive

HO Intercooled Tuner Kits

- Omits tuning and fuel system components
- Otherwise identical to HO Intercooled System

"Towing, better mileage, great power... and fun-to-drive performance. The ProCharger system easily satisfied our criteria" - Truckin'

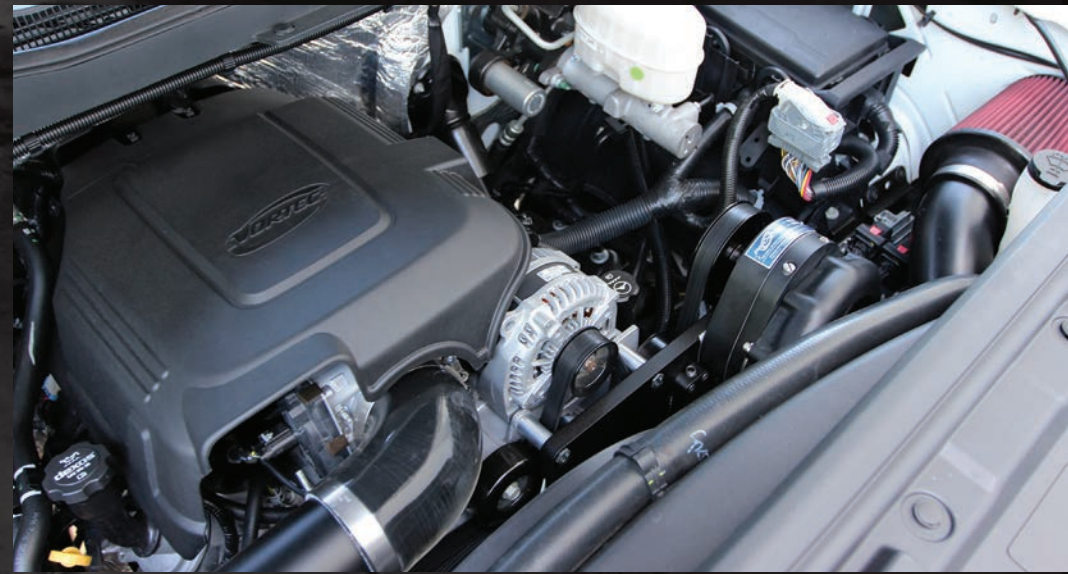

Optional Upgrades Include:

- Black or Polished finish for supercharger and/or bracket
- Helical gerset for noise reduction (P-1SC-1, P-1X, D-1SC, D-1X)
- ProCharger P-1X, D-1SC, D-1X and F-1 series supercharger upgrade



2014-2018 • 1500
2015-2020 • SUV
6.2L, 5.3L



2014-18 / 2015-2020 GM Truck/SUV's

When it comes to the 2014+ GM Trucks and SUVs, ProCharger is the power adder that does it all. Whether you are looking for a turn-key system to create a 600+ hp daily driver, or building a 1,200+ hp weekend track toy, ProCharger has the perfect system or kit for you. From billet gear cases on the self-contained head units, to the aircraft-grade, CNC-machined aluminum brackets, to the rugged, highly-effective air-to-air intercooler system, these systems were designed to look great and perform for decades. Designed to be easily installed in an afternoon in the garage with common hand tools, these ProCharger systems produce a reliable 45%+ horsepower gain with just 8 psi and factory fuel injectors, on otherwise stock engines running premium pump gas.

HO Intercooled System

- The Industry's coolest charge air temperatures and largest power gains
- ProCharger P-1SC-1, 3-year warranty available
- ProCharger's self-contained oiling design requires no external oil lines
- Large 3-core air-to-air intercooler is standard, 3-year standard warranty
- ProFlow blow-off valve
- Includes tuning
- System is 100% complete with OEM appearance and quality

Stage II Intercooled System

- 8-rib dedicated drive bracket system
- Otherwise Includes all HO items listed above

HO / Stage II Intercooled Tuner Kits

- Omits tuning, otherwise identical to system
- Head units up through F-1X optional

2014-20 GM Truck/SUV Systems & Tuner Kits Available for:

- | | | |
|-----------------------|------------------|-------------------------|
| • Chevrolet Silverado | • GMC Sierra | • Cadillac Escalade |
| • Chevrolet Suburban | • GMC Yukon, XL | • Cadillac Escalade ESV |
| • Chevrolet Tahoe | • GMC Denali, XL | |



HO Intercooled System



Optional Upgrades:

- Black or Polished finish for supercharger and/or bracket
- Helical gearset for noise reduction (P-1SC-1, P-1X, D-1SC, D-1X)
- ProCharger P-1X, D-1SC, D-1X and F-1 series supercharger head unit upgrade
- Race blow-off valve
- 10-rib drive upgrade (Stage II only)
- Option of rear or front-facing air inlet (for HO only)
- Vertical intercooler (replacing horizontal, truck only)



Stage II system

GM

2007-2013 • 1500
2007-2014 • SUV
6.2L, 6.0L, 5.3L, 4.8L



2007-2014 GM Truck/SUV

HO Intercooled ProCharger Systems for GM trucks and SUV's produce a 50-55% power gain on stock engines running pump gas with 8-9 psi (5.3L / 4.8L) or 7-8 psi (6.2L/6.0L) of intercooled boost on a shared 6-rib drive system. Stage II systems are also available, which include a 8-rib dedicated drive system and are otherwise identical to the HO intercooled systems. HO and Stage II Intercooled Tuner Kits and higher boost levels are available for modified engines. Industry-exclusive features of the 2007-14 GM truck/SUV kits include the proven and patented, self-contained ProCharger P-1SC-1 supercharger, and highly effective air-to-air intercooler.

HO Intercooled System

- The Industry's coolest charge air temperatures and largest power gains
- ProCharger P-1SC-1, 3-year warranty available
- ProCharger's patented, self-contained oiling design requires no external oil lines
- 3-core (6.0L / 6.2L) / 2 core (5.3L / 4.8L), air-to-air intercooler, 3-year standard warranty
- ProFlow blow-off valve
- Includes fuel injectors and tuning
- System is 100% complete with OEM appearance and quality

Stage II Intercooled System

- 8-rib dedicated drive bracket system
- Otherwise identical to HO Intercooled System

HO / Stage II Intercooled Tuner Kits

- Omits tuning and fuel system components
- Otherwise identical to HO / Stage II Intercooled System

"A huge dose of extra pulling capability throughout the power curve with great drivability.. The installed ProCharger system is designed with a factory look and appearance which we really like." -Truckin'



Forward facing inlet tube shown



Rear facing inlet tube shown



Optional Upgrades Include:

- Black or Polished finish for supercharger and/or bracket
- Helical gearset for noise reduction (P-1SC-1, P-1X, D-1SC, D-1X)
- ProCharger P-1X, D-1SC and D-1X supercharger head unit upgrade
- ProCharger F-1 and F-2 series supercharger head unit upgrade (Stage II)
- Race blow-off valve
- 10-rib drive upgrade (Stage II only)
- Option of rear or front-facing air inlet
- 3-core air-to-air intercooler (if not standard)
- Vertical Stage II Intercooler

2003-2007
6.0L, 5.3L, 4.8L

GM

2003-2007 GM Truck/SUV

ProCharger Intercooled Systems for the 2003-07 GM Truck & SUV offer industry-leading 55-65% power gains on stock engines running pump gas at 8-9 psi (5.3L / 4.8L) or 7-8 psi (6.0L) of intercooled boost. For modified engines, higher boost levels are available with the HO Intercooled and Stage II Intercooled Tuner Kits. ProCharger's American-made 2003-07 GM truck and SUV kits feature the patented and proven P-1SC self-contained supercharger and highly effective air-to-air intercooler system.

HO Intercooled System

- The Industry's coolest charge air temperatures and largest power gains
- ProCharger P-1SC, 3-year warranty available
- ProCharger's patented, self-contained oiling design requires no external oil lines
- 2-core air-to-air intercooler, 3-year standard warranty
- ProFlow blow-off valve
- Includes fuel injectors and tuning
- System is 100% complete with OEM appearance and quality

Stage II Intercooled System

- 8-rib dedicated drive bracket system
- ProCharger P-1SC-1, 3-year warranty available
- 3-core verticle intercooler (standard)
- Tuning and fuel injectors included

HO / Stage II Intercooled Tuner Kits

- Omits tuning and fuel system components
- Otherwise identical to HO / Stage II Intercooled System

"An intercooled ProCharger Tuner Kit like the one we chose supports the highest boost and power levels in the industry."—StreetTrucks.com



Optional Upgrades Include:

- Black or Polished finish for supercharger and/or bracket
- Helical gearset for noise reduction (P-1SC, P-1SC-1, D-1SC)
- ProCharger P-1SC-1 and D-1SC supercharger upgrade
- ProCharger F-1 series supercharger head unit upgrade (Stage II only)
- 3-core air-to-air intercooler
- 10-rib belt drive upgrade (Stage II only)



1999-2003 6.0L, 5.3L, 4.8L



1999-2003 GM Truck/SUV

For the best system efficiency and performance, look no further than ProCharger's HO Intercooled Systems and Kits for 1999-2003 GM Truck & SUV's that offer industry leading 55-65% power gains on stock engines running pump gas at 8-9 psi (5.3L / 4.8L) or 7-8 psi (6.0L) of intercooled boost. For modified engines, higher boost levels are available with the HO Intercooled and Stage II Intercooled Tuner Kits. These offerings feature the patented and proven P-1SC supercharger, and highly effective air-to-air intercooler system.

HO Intercooled System

- The Industry's coolest charge air temperatures and largest power gains
- ProCharger P-1SC, 3-year warranty available
- ProCharger's patented, self-contained oiling design requires no external oil lines
- 2-core air-to-air intercooler, 3-year standard warranty
- ProFlow blow-off valve
- Includes fuel system (FMU and pump)
- System is 100% complete with OEM appearance and quality

Stage II Intercooled System

- 8-rib dedicated drive bracket system
- 3-core verticle intercooler (standard)
- Tuning and fuel injectors included

HO / Stage II Intercooled Tuner Kits

- Omits tuning and fuel system components
- Otherwise identical to HO / Stage II Intercooled System



Optional Upgrades Include:

- Black or Polished finish for supercharger and/or bracket
- Helical gearset for noise reduction (P-1SC, P-1SC-1, D-1SC)
- ProCharger P-1SC-1, and D-1SC supercharger upgrade
- ProCharger F-1 series supercharger head unit upgrade (Stage II only)
- 10-rib drive (Stage II only)
- 3-core air-to-air intercooler

"We love it when a supercharger system like the ones from ProCharger under promise and over deliver" - Super Chevy

1988-2000

7.4L , 5.7L (VORTEC & TBI)

2003-2009 • Hummer H2

6.2L, 6.0L

GM



1988-2000 GM Truck/SUV

ProCharger HO Intercooled Systems for 1988-2000 GM trucks & SUVs produce power gains of 60-65% on stock engines running 8-9 psi of boost. Equipped with the ultra-efficient ProCharger air-to-air intercooler, these American-made systems will deliver the power to tow, and power to go. ProCharger's industry-leading supercharger and intercooler technology delivers cooler air, more sustainable torque, and substantially more total power than any other supercharger.

HO Intercooled System

- The Industry's coolest charge air temperatures and largest power gains
- ProCharger P-1SC, 3-year warranty available
- ProCharger's self-contained oiling design requires no external oil lines
- 2-core air-to-air intercooler, 3-year standard warranty
- ProFlow blow-off valve
- Includes fuel system (FMU and pump)
- System is 100% complete with OEM appearance and quality

HO Intercooled Tuner Kits

- Omits fuel system (FMU and pump)
- Otherwise identical to HO Intercooled System

Optional Upgrades Include:

- Black or Polished finish for supercharger and/or bracket
- Helical gearset for noise reduction (P-1SC, D-1SC)
- ProCharger D-1 and D-1SC supercharger upgrade



2003-2009 Hummer H2

The HO Intercooled Tuner Kits for the Hummer H2 utilize the patented, proven and self-contained P-1SC and P-1SC-1 ProChargers, a compact supercharger drive system, a highly-effective, air-to-air intercooler, OEM-quality mounting brackets, and all necessary supercharger and intercooler tubes for installation onto your Hummer H2 SUV engine.

ProCharger supercharger kits feature easy installation, minimal relocation of components, no need for external oil feed and return lines and avoids having to deal the complexity and maintenance issues of an air-to-water-to-air intercooler configuration. ProCharger kits for Hummer H2 SUVs feature a visually appealing, "from the factory" look and come with a standard 3-year warranty on the intercooler and 1-year warranty on the supercharger (Optional 3-year supercharger warranty is available on Tuner Kits).

HO Intercooled Tuner Kits

- ProCharger P-1SC / P-1SC-1
- ProCharger's self-contained oiling design requires no external oil lines
- H2 air-to-air intercooler, 3-year standard warranty
- ProFlow blow-off valve
- Fuel system components not included

Optional Upgrades Include:

- Black or Polished finish for supercharger and/or bracket
- Helical gearset for noise reduction (P-1SC, P-1SC-1, D-1SC)
- ProCharger P-1SC-1 and D-1SC supercharger upgrade



2021-2023 F-150 5.0L



2021-2023 F-150 Truck

Turn your F-150 into an absolute horsepower and torque monster in the easiest way possible with ProCharger's easy-to-install supercharger system that yields massive 55-75% power gains! Even with that huge power increase, driving manners are as good as stock, if not better. Plus, all that extra power pairs perfectly with the transmission's shift points by utilizing the optimized power band that the ProCharger delivers. The HO and Stage II systems use a highly durable P-1SC-1 supercharger to make 8-10 psi of boost and generate 55-75% power gains on stock engines running premium gas. The highly effective 3-core air-to-air intercooler ensures the coolest air charge temps possible, while also having no moving parts to fail (no pumps, wires, reservoir, etc.). Systems and kits included everything needed to install, down to the aluminum charge tubing, silicone couplers, and factory connectors, and do not require any permanent modifications.

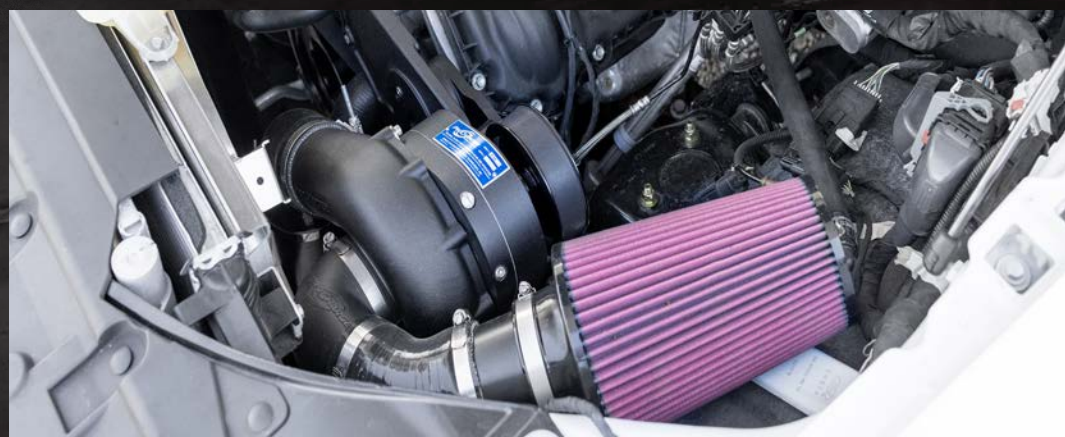

HO Intercooled System

- ProCharger P-1SC-1, 3-year warranty available
- 8 psi of boost
- ProCharger's patented, self-contained oiling design requires no external oil lines
- 3-core air-to-air intercooler, 3-year standard warranty
- 6-rib shared drive bracket system is standard
- Utilizes factory airbox
- ProFlow blow-off valve
- Includes tuning and handheld programmer
- System is 100% complete with OEM appearance and quality

Stage II Intercooled System

- 10 psi of boost
- Air-to-air race intercooler
- 8-rib dedicated drive standard, with optional 10 rib upgrade

HO / Stage II Intercooled Tuner Kits

- Omits tuning
- Otherwise identical to Intercooled Systems



Optional Upgrades Include:

- Black or Polished finish for supercharger and/or bracket
- Helical gearset for noise reduction (P-1SC-1, P-1X, D-1SC, D-1X)
- Race blow-off valve (Tuner Kit only)
- Crank support for ultra-high HP builds
- Black or Polished finish for Crank Support
- Air-to-Air Race intercooler upgrade (from 3 core)
- ProCharger P-1X, D-1SC, D-1X and up to F-1A-94 supercharger head unit upgrade
- Mustang intake manifold upgrade (+50 rwhp), includes custom tune and engine spacers

2020-2023

F-250/F-350 7.3L



2020-2023 F-250/350 Truck

ProCharger's complete HO system for Ford F-250 and F-350 Super Duty trucks uses a proven P-1SC-1 supercharger head unit (others are available as options in the Tuner Kit) with bulletproof air-to-air intercooling making 7-8 psi of boost and generating 45+% more power than stock. This supercharger system also works perfectly with the truck's 10-speed automatic transmission, keeping the boost level consistent and highly efficient. That is power you can FEEL both on the street and while pulling a heavy load. Power you NEED from your new Super Duty Ford.

Does your F-250 have dual alternators and dual batteries? We have you covered! The second alternator is removed to make room for the supercharger and bracket assembly. However, the second battery is retained with the factory coolant tank and battery assembly tray.

*"Fun to drive, with the acceleration of a sports car, and greatly improved torque that can help bring towing capability on par with 6.7L diesel-powered trucks, for a lot less money." - **MOTORTREND***

HO Intercooled System

- ProCharger P-1SC-1, 3-year warranty available
- ProCharger's patented, self-contained oiling design requires no external oil lines
- 3-core air-to-air intercooler, 3-year standard warranty
- 6-rib shared drive bracket system is standard
- Bullet blow-off valve
- Includes injectors and tuning
- System is 100% complete with OEM appearance and quality

HO Intercooled Tuner Kits

- Omits injectors and tuning
- Otherwise identical to Intercooled Systems



Optional Upgrades Include:

- Black or Polished finish for supercharger and/or bracket
- Black or Polished finish for Crank Support
- Helical gearset for noise reduction (P-1SC-1, P-1X, D-1SC, D-1X)
- ProCharger P-1X, D-1SC, D-1X and up to F-1A supercharger head unit upgrade

"The ten-speed automatic transmission compliments the blower, maintaining boost throughout the powerband" - Truck Trend



2018-2020 F-150 5.0L

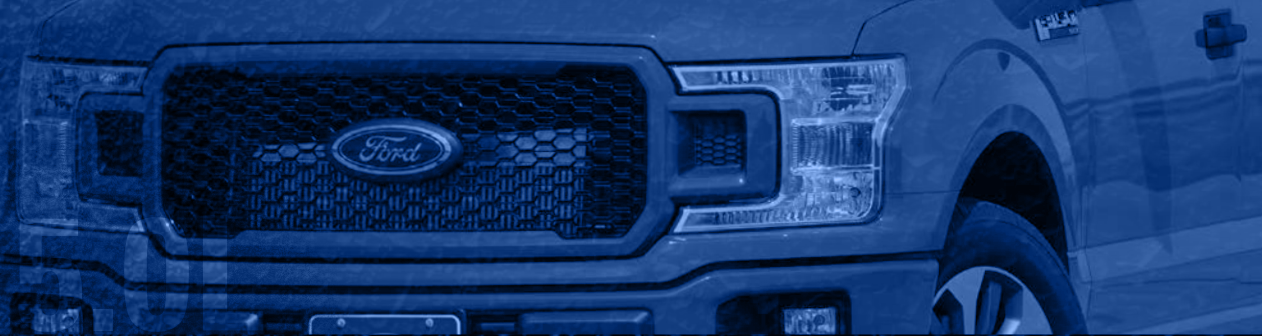

2018-2020 F-150 Truck

The HO Intercooled System for the 2018-20 F-150 5.0L 4V delivers an impressive 45-55% HP power gain on just 6 psi of boost utilizing our patented and durable P-1SC-1 self-contained supercharger, built to last for many miles. This HO system comes standard with our large 3-core intercooler for cooler air and higher performance while utilizing the factory fuel injectors and running on premium gas. This supercharger system also works perfectly with the truck's 10-speed automatic transmission, keeping the boost levels consistent and highly efficient.

For those F-150 owners seeking maximum performance, our Stage II System delivers a massive 60-70% HP gain on an engine friendly 8-9 psi of boost, with an air-to-air Race Intercooler with a 4.5" thick core for maximum cooling performance.

HO Intercooled System

- ProCharger P-1SC-1, 3-year warranty available
- ProCharger's patented, self-contained oiling design requires no external oil lines
- 3-core air-to-air intercooler, 3-year standard warranty
- 8-rib dedicated drive bracket system is standard
- ProFlow blow-off valve
- Includes tuning and handheld programmer
- System is 100% complete with OEM appearance and quality

Stage II Intercooled System

- 8-9 psi of boost
- Air-to-air race intercooler

HO / Stage II Intercooled Tuner Kits

- Omits tuning and fuel system components



Optional Upgrades Include:

- Black or Polished finish for supercharger and/or bracket
- Polished or Black finish for crank support
- Helical gearset for noise reduction (P-1SC-1, P-1X, D-1SC, D-1X)
- ProCharger P-1X, D-1SC, D-1X and F-1 series supercharger head unit upgrade
- Race blow-off valve (Tuner Kit only)
- Crank support for ultra-high HP builds

"ProCharger adds serious HP to the new Ford...with all the hardware and tuning included, and the full system can be installed in no time" - Truck Trend

2015-2017
F-150 5.0L



2015-2017 F-150 Truck

Bolt on up to 60-70% more power! The systems for 2015-17 Ford F-150 trucks with 5.0L 4V engine features an easily installed design with the self-contained P-1SC-1 supercharger and a large 3-core intercooler. The 5.0L HO Intercooled systems produce a reliable 45-55% power gain with just 6-7 psi and factory fuel injectors, on otherwise stock engines running pump gas. 60-70% power gains are possible with the Stage II Intercooled system, which features 8-9 psi, upgraded fuel injectors and air-to-air Race Intercooler with a 4.5" thick core.

HO Intercooled System

- ProCharger P-1SC-1, 3-year warranty available
- ProCharger's patented, self-contained oiling design requires no external oil lines
- 3-core air-to-air intercooler, 3-year standard warranty
- 8-rib dedicated drive bracket system is standard
- ProFlow blow-off valve
- Includes tuning and handheld programmer
- System is 100% complete with OEM appearance and quality

Stage II Intercooled System

- Race air-to-air intercooler with 4.5" thick core
- 8-9 psi of boost, upgraded fuel injectors
- Otherwise identical to HO Intercooled System

HO / Stage II Intercooled Tuner Kits

- Omits tuning and fuel system components
- Otherwise identical to Intercooled Systems



Optional Upgrades Include:

- Black or Polished finish for supercharger and/or bracket
- Polished or Black finish for crank support
- Helical gearset for noise reduction (P-1SC-1, P-1X, D-1SC, D-1X)
- ProCharger P-1X, D-1SC, D-1X and F-1 series supercharger head unit upgrade
- Race blow-off valve (Tuner Kit only)
- Larger Race air-to-air intercooler with 4.5" thick core
- Crank support for ultra-high HP builds

"We were looking forward to a few more MPGs and a whole lot of power, but the peak horsepower of 536 pretty much blew our minds. That's nearly 200hp over stock!"

- Truck Trend



2011-2014 F-150 5.0L



2011-2014 F-150

The HO Intercooled System for 2011-14 Ford F-150 trucks with 5.0L 4V engines features an easily installed design with self-contained P-1SC-1 supercharger and 3-core intercooler. The systems produce a reliable 45-55% power gain with just 6-7 psi and factory fuel injectors, on otherwise stock engines running pump gas. With the 5.0L Stage II Intercooled System, 60-70% power gains are possible. It features 8-9 psi, larger fuel injectors, and air-to-air Race Intercooler.

HO Intercooled System

- ProCharger P-1SC-1 3-year warranty available
- ProCharger's patented, self-contained oiling design requires no external oil lines
- 3-core air-to-air intercooler, 3-year standard warranty
- ProFlow blow-off valve
- Includes tuning and handheld programmer
- System is 100% complete with OEM appearance and quality

Stage II Intercooled System

- Race air-to-air 4.5' thick 3-core intercooler
- 8-9 psi of boost, upgraded fuel injectors
- Otherwise identical to HO Intercooled System

HO / Stage II Intercooled Tuner Kits

- Omits tuning and fuel system components
- Otherwise identical to Intercooled Systems

"The ProCharger kits come complete with all the parts and hardware to do the job" - Truckin'



Forward Facing Air Inlet, Black Finish



Stage 2 Intercooler



Optional Upgrades Include:

- Black or Polished finish for supercharger and/or bracket
- Black or Polished finish for Crank Support
- Helical gearset for noise reduction (P-1SC-1, P-1X, D-1SC, D-1X)
- ProCharger P-1X, D-1SC, D-1X and F-1 series supercharger
- Race blow-off valve (Tuner Kit only)
- Forward-facing air inlet (rear-facing is standard)
- Crank support for ultra-high HP builds



Standard Air Inlet, Satin Finish



2010-2014 SVT RAPTOR 6.2L, 5.4L 2011-2014 F-150 6.2L



2010-2014 SVT Raptor 6.2L and 5.4L, F-150 6.2L

ProCharger was first to market with a complete air-to-air intercooled supercharger system for work hard, play hard Ford F-150 trucks. The HO Intercooled System features the P-1SC-1 supercharger and a highly effective air-to-air intercooler. HO Systems are 100% complete with all mounting hardware, tubing and tuning included. ProCharger systems for F-150's produce 50-65% power gains from 8-9 psi of boost on otherwise stock engines running high quality pump gas. HO Intercooled Tuner Kits and higher boost levels are available for modified engines.

HO Intercooled System for 6.2L and 5.4L

- ProCharger D-1SC-1 self-contained head unit
- 1-year warranty, 3-year optional
- 3-core air-to-air intercooler
- 6-rib shared drive bracket system
- ProFlow blow-off valve
- Includes tuning and handheld programmer
- System is 100% complete with OEM appearance and quality

Stage II Intercooled System

- 8-rib dedicated drive bracket system is standard
- ProCharger P-1SC-1 self-contained head unit
- Larger Race air-to-air intercooler with 4.5" thick core
- Otherwise identical to HO Intercooled System

HO / Stage II Intercooled Tuner Kits for 6.2L and 5.4L

- Omits tuning and fuel system components
- Otherwise identical to HO Intercooled System

Optional Upgrades Include:

- Black or Polished finish for supercharger and/or bracket
- Helical gearset for noise reduction (P-1SC-1, P-1X, D-1SC, D-1X)
- ProCharger P-1X, D-1SC, D-1X and F-1 series supercharger head unit upgrade
- Race blow-off valve



F150 (2015-20) / Raptor (2017-20) EcoBoost Intercooler

F150 and Raptor EcoBoost owners can upgrade to one of the biggest and most effective intercooler options available. The ProCharger Raptor intercooler upgrade provides much lower air inlet temps and a lower pressure drop for improved performance, even in extreme conditions. All hardware and piping is included. Tuning is not included.





2009-2010

F-150 5.4L

2004-2008

F-150 5.4L



2009-2010 & 2004-2008 F-150 Truck

The High Output Intercooled System for the 2009-2010 & 2004-2008 Ford F-150 with the 5.4L 3V engine produces an industry leading 60-65% power gain on 8-9 psi of intercooled boost on otherwise stock engines running premium gas.

HO Intercooled System

- The Industry's coolest charge air temperatures and largest power gains
- ProCharger's patented, self-contained oiling design requires no external oil lines
- 2-core air-to-air intercooler, 3-year standard warranty
- ProFlow blow-off valve
- Includes tuning
- System is 100% complete with OEM appearance and quality

HO Intercooled Tuner Kit

- Omits tuning and fuel system components
- Otherwise identical to HO Intercooled System

Optional Upgrades Include:

- Black or Polished finish for supercharger
- Helical gearset for noise reduction (P-1SC-1 and D-1SC)
- D-1SC upgrade from P-1SC-1
- 3-core air-to-air intercooler



"Much as the ProCharger intercooler changed the supercharger kit landscape, so did ProCharger's precision-ground internal gearbox" - MotorTrend

2007-2014 Expedition 5.4L

ProCharger HO Intercooled Systems provide a ground pounding 60-65% power gain with 8-9 psi of intercooled boost on stock engines running high quality pump gas. They also feature a highly efficient air-to-air intercooler and self-contained P-1SC-1 supercharger. Tuner Kits for higher boost levels are available.



1997-2003 F-150 5.4L, 4.6L



1997-2003 EXPEDITION 5.4L, 4.6L

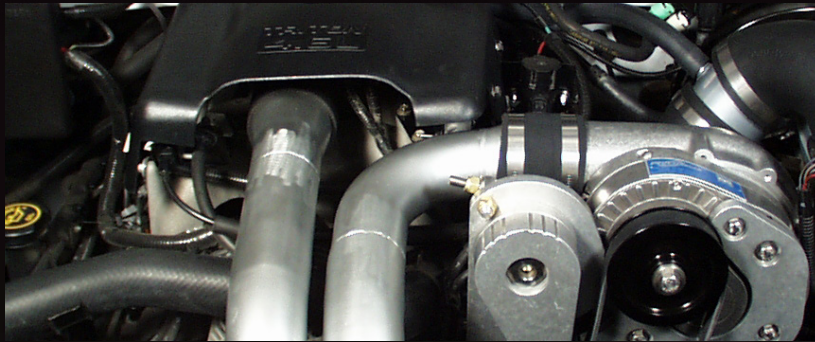

1997-2003 F-150 Truck

ProCharger HO Systems for the 1997-2003 Ford F-150 produce power gains of 60-65% with 8-9 psi of intercooled boost on otherwise stock engines running premium gas. Tuner Kits and higher boost levels are available for modified engines.

HO Intercooled System

- The Industry's coolest charge air temperatures and largest power gains
- ProCharger P-1SC, 3-year warranty available
- ProCharger's patented, self-contained oiling design requires no external oil lines
- 2-core air-to-air intercooler (1997-98), 3 core (1999-2003), 3-year standard warranty
- ProFlow blow-off valve
- Includes fuel system (FMU and pump)
- System is 100% complete with OEM appearance and quality

HO Intercooled Tuner Kits

- Omits fuel system (FMU and pump)
- Otherwise identical to HO Intercooled System

Optional Upgrades Include:

- Black or Polished finish for supercharger
- Helical gearset for noise reduction (P-1SC and D-1SC)
- D-1SC upgrade from P-1SC



1997-2003 Ford Expedition

Producing 60-65% power gains from 8-9 psi of boost on otherwise stock engines running high quality pump gas, these systems also deliver a smooth performance curve, mpg-friendly high performance, and excellent daily driveability.

HO Intercooled System

- The Industry's coolest charge air temperatures and largest power gains
- ProCharger P-1SC, 3-year warranty available
- ProCharger's patented, self-contained oiling design requires no external oil lines
- 2-core air-to-air intercooler (1997-98), 3 core (1999-2003), 3-year standard warranty
- ProFlow blow-off valve
- Includes fuel system-FMU and pump
- System is 100% complete with OEM appearance and quality

HO Intercooled Tuner Kit

- Omits fuel system components
- Otherwise identical to HO Intercooled System

Optional Upgrades Include:

- Black or Polished finish for supercharger
- Helical gearset for noise reduction (P-1SC and D-1SC)
- D-1SC upgrade from P-1SC



2019-2023 RAM 1500 5.7L RAM 1500 5.7L eTORQUE



2019-2023 Ram

When you are looking to add power to your truck, you want BIG, seat-of-the-pants gains. Thankfully for RAM owners, ProCharger has the answer to your calls in the form of 140-160 tire-ripping horsepower that you can bolt on in your garage. That's right, no internal engine modifications are needed, and the kits and systems work on the standard 5.7L and the eTorque as well.

No matter if you are pulling the boat to the lake, or daily driving to the job site, these ProCharger systems bring you not only the biggest gains possible, but also are designed to be rugged and reliable for years and years of use. Full systems include everything you need to install, including the reprogramming for the ECU that makes it possible to have this much more power on premium pump fuel and have the silky smooth drivability that ProCharger delivers.

HO Intercooled System (non eTorque)

- ProCharger D-1SC
- ProCharger's patented, self-contained oiling design requires no external oil lines
- 3-core air-to-air intercooler, 3-year standard warranty
- Shared 6-rib drive bracket system
- ProFlow blow-off valve
- Includes fuel system and tuning

Stage II Intercooled System (and eTorque)

- ProCharger P-1SC-1
- 8-rib dedicated drive bracket system
- 3-core air-to-air intercooler with a 3-year standard warranty
- ProFlow blow-off valve
- ProCharger's patented, self-contained oiling design requires no external oil lines
- Includes fuel system and tuning

HO / Stage II Intercooled Tuner Kits

- Omits tuning and fuel system components
- Otherwise identical to Intercooled Systems



Optional Upgrades Include:

- Black or Polished finish for supercharger and/or bracket
- Helical gearset for noise reduction (P-1SC-1, P-1X, D-1SC, D-1X)
- ProCharger P-1X, D-1SC, D-1X and up to F-1A-94 supercharger head unit
- Race blow-off valve

"ProCharger did its job quite well and had all the necessary parts to make this install a breeze" - Truck Trend

2009-2023 RAM 1500 5.7L CLASSIC



2009-2023 Dodge HEMI Ram Classic

ProCharger leads the market with air-to-air intercooled supercharger systems for the 2009-2023 Dodge Ram 5.7L Classic HEMI truck. High Output Intercooled ProCharger Systems for 5.7L Rams produce an industry leading power gain (+140 HP for 2011-2023 Rams, +130 for 2009-2010 Rams) on otherwise stock engines running high quality pump gas with just 7 psi of intercooled boost. HO Intercooled Tuner Kits with higher boost levels and power gains are available for modified engines.

HO Intercooled System

- The Industry's coolest charge air temperatures and largest power gains
- ProCharger P-1SC-1 (2009-2010), ProCharger D-1SC (2011-2023)
- ProCharger's patented, self-contained oiling design requires no external oil lines
- 3-core air-to-air intercooler with a 3-year standard warranty
- ProFlow blow-off valve
- Includes fuel injectors and tuning

Stage II Intercooled System

- 8-rib dedicated drive
- ProCharger P-1SC-1 standard

HO / Stage II Intercooled Tuner Kits

- Omits tuning and fuel system components
- Otherwise identical to HO / Stage II Intercooled System

Optional Upgrades Include:

- Black or Polished finish for supercharger and/or bracket
- Helical gerset for noise reduction (P-1SC-1, P-1X, D-1SC, D-1X)
- ProCharger P-1X, D-1SC, D-1X and up to F-1A-94 supercharger head unit
- Race blow-off valve



Hey, does that thing have a ProCharger? The only thing better than being able to say that you have a HEMI, is being able to say you have a ProCharged HEMI!

"Fit and finish was second to none, drivability remained intact, and it was a complete bolt-on" - Truck Trend



2014-2023 RAM 2500 6.4L



2014-2023 Dodge HEMI Ram

ProCharger's expansive truck/suv lineup includes a complete air-to-air intercooled supercharger system for 2014-2023 Ram 2500/3500 trucks with the 6.4L engine. These new High Output Intercooled Systems feature a shared-drive design that produce a reliable 130+ HP gain with only 6 psi on otherwise stock engines running premium gas.

Intercooled ProCharger Systems and Tuner Kits provide the coolest charge air temperatures, largest power gains and most repeatable performance available for your HEMI. ProCharger's 6.4L Systems and Tuner kits for these Ram trucks feature a D-1SC ProCharger standard. Both of these industry-leading supercharger models feature self-contained oiling that eliminates the need for external oil lines or the need to tap into the engine's oil supply. This patented feature simplifies the installation while also providing superior lubrication and lower supercharger oil temperatures.

Systems and Kits also feature highly effective and reliable air-to-air intercooling with a large 3-core intercooler, and your choice of supercharger gearset: standard or the helical gearset option for lower supercharger noise levels. As if that wasn't enough, you now also have your choice of multiple supercharger and bracket finishes: black or polished finish.

HO Intercooled System

- The Industry's coolest charge air temperatures and largest power gains
- ProCharger's patented, self-contained oiling design requires no external oil lines
- 3-core air-to-air intercooler with a 3-year standard warranty
- ProFlow blow-off valve
- Includes fuel injectors and tuning

"We were pretty stoked with the results: 441 rwhp and 417 lb-ft of torque! That's a gain of 154 ponies [at the tire] and 103 lb-ft! Not bad for a day's work on an otherwise stock engine" - Truckin'



HO Intercooled Tuner Kits

- Omits tuning and fuel system components
- Otherwise identical to HO Intercooled System

Optional Upgrades Include:

- Black or Polished finish for supercharger and/or bracket
- Helical gearset for noise reduction
- Power Wagon winch compatible

2004-2008 RAM 1500 5.7L



2004-2008 Dodge HEMI Ram

ProCharger High Output Intercooled Systems for 2004-2008 Dodge HEMI Ram 5.7L trucks produce power gains of 45-50% on stock engines running premium pump gas with only 6 psi of intercooled boost. Featuring the coolest charge air temperatures available, the ProCharged HEMI Ram system delivers industry leading power gains and superior engine longevity. Industry exclusive features include a 3-core air-to-air intercooler system, and patented self-contained supercharger with available 3-year warranty. The HO Intercooled ProCharger System is 100% complete, with larger injectors and programming to ensure superior performance. HO Intercooled Tuner Kits and higher boost levels are available for modified engines.

HO Intercooled System

- The Industry's coolest charge air temperatures and largest power gains
- ProCharger P-1SC-1, 3-year warranty available
- ProCharger's patented, self-contained oiling design requires no external oil lines
- 3-core air-to-air intercooler with a 3-year standard warranty
- ProFlow blow-off valve
- Includes fuel injectors and tuning
- System is 100% complete with OEM appearance and quality

HO Intercooled Tuner Kits

- Omits tuning and fuel system components
- Otherwise identical to HO Intercooled System

Optional Upgrades Include:

- Black or Polished finish for supercharger and/or bracket
- Helical gearset for noise reduction (P-1SC-1 and D-1SC)
- D-1SC upgrade from P-1SC-1



Sometimes it is nice to know you have options. When you are talking about adding a ton of power to your 2004-2008 HEMI Ram this is especially true. ProCharger brings you the best bolt-on power and coolest charge air temperatures available for your HEMI Ram plus an upgrade path that is second to none. Options include high and low mount air-to-air intercoolers, supercharger head unit upgrades, polished finishes and helical cut (noise reduction) gearset just to name a few. ProCharger provides the options to upgrade and individualize your truck because after all, your truck is an extension of who you are.



1996-2001 RAM / DAKOTA / DURANGO 5.9L, 5.2L

1996-2001 Ram / 1997-2001 Dakota/Durango

The High Output Intercooled Kit for the 1996-2001 Dodge Ram and 1997-2001 Dodge Dakota / Durango with 5.9L or 5.2L engines produce an industry leading 55-60% power gain on 8-9 psi of intercooled boost on otherwise stock engines running premium pump gas. The HO Kit comes standard with a highly-effective 2-core air-to-air intercooler and the best upgrade options in the industry. Higher boost levels are available for modified engines.

HO Intercooled Tuner Kits

- The Industry's coolest charge air temperatures and largest power gains
- ProCharger P-1SC
- ProCharger's patented, self-contained oiling design requires no external oil lines
- 2-core air-to-air intercooler
- ProFlow blow-off valve

Optional Upgrades Include:

- Black or Polished finish for supercharger
- Helical gearset for noise reduction (P-1SC-1, D-1SC)
- D-1SC upgrade from P-1SC
- 3-core air-to-air intercooler (Ram only)



"The mad scientists over at ProCharger have been designing industry leading supercharger systems since 1993."

- Truck Trend

No need to worry if you don't have a HEMI-powered truck—ProCharger has you covered with bolt on, intercooled power for your 1996-2001 Ram or 1997-2001 Dodge Dakota with the Magnum 5.9L or 5.2L engine. In fact, ProCharger offers the only intercooled supercharger kit for the Magnum Ram and Dakotas. ProCharger continues to bring you the broadest offering in the industry.

2018-2023 DURANGO SRT 6.4L

2018-2023 Durango SRT

With an additional 215+ horsepower now on tap at just 7 psi of boost on pump gas, we can assure you the factory tires will do everything they can to help grip the road for sub 4.0 second 0-60 mph times. ProCharger HO Intercooled Systems are supplied with our patented self-contained P-1SC-1 supercharger and with additional supercharger upgrades available (see options below), proven tuning calibrations, and a handheld programmer. Higher boost levels and horsepower are possible with an Intercooled Tuner Kit and custom tuning.

HO Intercooled System

- The Industry's coolest charge air temperatures and largest power gains
- ProCharger P-1SC-1, 3-year warranty available
- ProCharger's patented, self-contained oiling design requires no external oil lines
- 3-core air-to-air intercooler with a 3-year standard warranty
- ProFlow blow-off valve
- Includes fuel injectors and tuning

HO Intercooled Tuner Kits

- Omits tuning and fuel system components
- Otherwise identical to HO Intercooled System

Optional Upgrades Include:

- Black or Polished finish for supercharger and/or bracket
- Helical gearset for noise reduction (P-1SC-1, P-1X, D-1SC, D-1X)
- D-1SC upgrade from P-1SC-1, 9 inch F-1A Series model also available
- Race blow-off valve



CALL FOR DURANGO 5.7L INFO

"That was the most cool-sounding 582 HP I've ever heard [RWHP, 7 psi otherwise stock 6.4L SUV]" – Engine Power

Jeep

2020-2023 GLADIATOR JT 3.6L



2020-2023 Jeep Gladiator JT

ProCharger's supercharger technology and quality is the best available, and the company has been the leader for Jeep supercharging for nearly 20 years. ProCharger was the first to produce a supercharger system for the Gladiator, delivering the ultimate power gains, reliability and ease of installation. The HO Intercooled System features a shared-drive design for the highly efficient P-1SC-1 supercharger, and comes standard with the largest and most effective air-to-air intercooler for the Jeep Gladiator JT. These new systems produce a reliable 40-45%+ horsepower gain with just 7 psi on otherwise stock 3.6L engines running premium pump gas. Available with a best-in-class towing capacity of 7,650-pounds, adding a ProCharger system will make towing a breeze for your Jeep Gladiator.

Offering the easiest and quickest installation available, our Systems and Tuner Kits were designed with simplicity in mind. No permanent modifications are required and with only minor trimming of fan shroud needed for a simple installation.

With both the HO Intercooled System and Tuner Kit you also have your choice of the helical gearset option for lower supercharger noise levels, and your choice of multiple supercharger and bracket finishes—black or polished finish. Black finish is also available for the intercooler.

HO Intercooled System

- The Industry's coolest charge air temperatures and largest power gains
- ProCharger P-1SC-1, 3-year warranty available
- ProCharger's patented, self-contained oiling design requires no external oil lines
- 6-rib shared drive bracket system
- Large intercooler made for the Jeep Wrangler JT to maximize core size
- ProFlow blow-off valve
- Includes fuel injectors and tuning

HO Intercooled Tuner Kit

- Omits tuning and fuel system components
- Otherwise identical to HO Intercooled System



Optional Upgrades Include:

- Black or Polished finish for supercharger and/or bracket
- Black intercooler finish (raw finish standard)
- Helical gearset for noise reduction (P-1SC-1 and D-1SC)
- D-1SC upgrade from P-1SC-1

"ProCharger's supercharger kit for the Jeep Gladiator JT is a home run when it comes to reliable power and remarkable torque" - Off Road Xtreme



2018-2023 WRANGLER JL 3.6L

Jeep

2018-2023 Jeep Wrangler JL

ProCharger was the first to produce a supercharger system for the Jeep JL, and delivers industry leading power gains, quality, reliability and ease of installation. The HO Intercooled System features a shared-drive design for the highly efficient P-1SC-1 supercharger, and comes standard with the largest and most effective air-to-air intercooler. These new systems produce a reliable 40-45%+ horsepower gain with just 7 psi, on otherwise stock 3.6L engines running premium pump gas.

Featuring the easiest and quickest installation, our kits were designed with simplicity in mind. No permanent modifications are required and with only minor trimming of fan shroud needed for a simple installation.

With both the HO Intercooled System and Tuner Kit you also have your choice of the helical gearset option for lower supercharger noise levels, and your choice of multiple supercharger and bracket finishes—black or polished finish. Black finish is also available for the intercooler.

HO Intercooled System

- The Industry’s coolest charge air temperatures and largest power gains
- ProCharger P-1SC-1, 3-year warranty available
- ProCharger’s patented, self-contained oiling design requires no external oil lines
- 6-rib shared drive bracket system
- Large intercooler made for the Jeep Wrangler JL to maximize core size
- ProFlow blow-off valve
- Includes fuel injectors and tuning

HO Intercooled Tuner Kits

- Omits tuning and fuel system components
- Otherwise identical to HO Intercooled System



Optional Upgrades Include:

- Black or Polished finish for supercharger and/or bracket
- Black intercooler finish (raw finish standard)
- Helical gearset for noise reduction (P-1SC-1 and D-1SC)
- D-1SC upgrade from P-1SC-1

“A pleasure to experience on or off road...you can add a ton of power to pass with the big tires, and crawl over any boulders you can find by bolting on a highly efficient ProCharger supercharger”. - Off Road Xtreme



2012-2018 Jeep Wrangler JK

ProCharger's supercharger technology and quality is the best available, delivering the ultimate power gains, reliability and ease of installation. The proven HO Intercooled System produces a reliable 50%+ HP gain with just 7 psi, on otherwise stock 3.6L engines running pump gas. Featuring a shared-drive design for the highly efficient P-1SC-1 supercharger, the kit comes standard with the industry's largest and most effective air-to-air intercooler for the Jeep Wrangler JK. With the easiest and quickest installation available, our kits were designed with simplicity in mind—no permanent modifications are required, with no cutting, bending, or drilling necessary. Even with the industry's-best belt wrap, you can still swap supercharger pulleys in a matter of minutes and change the serpentine belt without removing the supercharger or any accessories.

HO Intercooled System

- The Industry's coolest charge air temperatures and largest power gains
- ProCharger P-1SC-1, 3-year warranty available
- ProCharger's patented, self-contained oiling design requires no external oil lines
- Large intercooler made for the Jeep Wrangler JK to maximize core size
- ProFlow blow-off valve
- Includes fuel injectors and tuning

HO Intercooled Tuner Kits

- Omits tuning and fuel system components
- Otherwise identical to HO Intercooled System



FOR OPTIONAL UPGRADES, SEE BOTTOM OF PAGE 35

"ProCharger has a 24+ year history of supercharger innovation, and their systems are Made in America. Producing a 50% power gain over stock at just 7 pounds of boost, this kit is a turnkey system... with the largest intercooler available for JK's, and great longevity" -Off Road Xtreme

	ProCharger	Other Centrifugal Kits	PD / Screw
Cutting:	none	intake manifold, fan, radiator hose, heater hose, body/frame	none
Bending:	none	heater hose hard lines, power steering line, air conditioner lines	none
Drilling:	none	frame/body for coolant tank mounting	none
Removed For Install:	alternator	fan, p/s pump and reservoir, drain coolant, radiator cover/brackets	drain coolant, heater lines, alternator, lower intake
Tuning:	CARB certified PCM calibration included	start-up tune only (will need full dyno tune)	CARB certified PCM tune included
Non-Factory Parts:	coolant tank, trans cooler, belt	coolant tank, trans cooler, belt tensioner	lower intake, belt, belt bracket
Intercooler Tubes:	six (6)	eight (8)	more complex air-to-water install
Major Features:	no permanent modifications, easier installation, more belt/pulley wrap, easier pulley change and belt removal, improved inlet, larger intercooler, bypass valve before intercooler, boost curve that matches the multispeed transmission	alternator remains in factory location, no MAP sensor adapter	no permanent modifications, system comes complete

2012-2020 GRAND CHEROKEE SRT 6.4L

Jeep

2012-2020 Grand Cherokee SRT8

ProCharger HO Intercooled Systems are supplied with the patented self-contained P-1SC-1 supercharger, proven tuning calibrations, and a handheld programmer set for a 215+ horsepower gain over stock, on 7 psi of boost and pump gas. Higher boost levels and horsepower are possible with an Intercooled Tuner Kit and custom tuning, and even higher with modified motors. The HO system is 100% reversible, with no trimming or cutting to any factory OEM plastics or hardware. As if that wasn't enough, you also have your choice of multiple supercharger and bracket finishes: black or polished finish.

HO Intercooled System

- 215+ horsepower gain with P-1SC-1 on 7 psi, pump gas
- Self-contained oiling design—no external oil lines
- ProCharger P-1SC-1, 3-year warranty available
- PCM Tuning supplied (complete system only)
- Highly effective, large air-to-air intercooler and 3.50" cold-side tubing
- No cutting or trimming required of OEM parts
- No need to drain the cooling system

HO Intercooled Tuner Kits

- Omits tuning and fuel system components
- Otherwise identical to HO Intercooled System

Optional Upgrades Include:

- Black or Polished finish for supercharger and bracket finish
- Helical gasket for noise reduction (P-1SC-1, P-1X, D-1SC, D-1X)
- Tuner Kits allow for P-1X, D-1SC, and up to F-1A-94 upgrades
- Race blow-off valve upgrade available (Tuner Kits only)
- Race intercooler upgrade



"The stock 0-60 time was 4.8-seconds. With the ProCharger installed, it was a very impressive 3.8 sec 0-60. That's a difference you can feel!" – Engine Power

FOR JEEP GRAND CHEROKEE 5.7L SEE PAGE 38

CALL FOR 2021+ GRAND CHEROKEE

Jeep

2011-2020 GRAND CHEROKEE 5.7L

2011-2020 Jeep Grand Cherokee

No matter if you are looking to add a bit more “fun” to your daily commute or possibly that extra “grunt” when you tow, this new ProCharger supercharger system delivers up to 160+ horsepower. For those of you that did the math that puts you OVER the rating of the SRT 6.4L Grand Cherokees (at a fraction of the price). Our system also creates sports car like 0-60 mph times, it can only be described as a true “sleeper” of an SUV.

With 7 psi of intercooled boost coming from the highly efficient P-1SC-1 head unit and premium pump gas, you can enjoy that HUGE gain in power. In addition, you can have confidence in the reliability that ProCharger delivers in their power gains and ECM programming for years and years of trouble free performance. ProCharger has been setting the bar for decades on intercooled centrifugal supercharged performance and still does today. Our air-to-air intercooler is the key to keeping inlet air temps to a minimum and power and reliability at a maximum.

HO Intercooled System

- 160+ horsepower gain with P-1SC-1 on 7 psi, pump gas
- Self-contained oiling design—no external oil lines
- ProCharger P-1SC-1, 3-year warranty available
- PCM Tuning supplied (complete system only)
- Billet impeller and supercharger gear cases, with industry-leading 4.10:1 step-up ratio
- Highly effective, large air-to-air intercooler and 3.50” cold-side tubing
- No cutting or trimming required of OEM parts
- No need to drain the cooling system

HO / Stage II Intercooled Tuner Kits

- Omits tuning and fuel system components
- Otherwise identical to HO Intercooled System

“ProCharger really does their homework, designing powerful supercharger kits that don’t sacrifice driveability or reliability”
- Mopar Muscle



Optional Upgrades Include:

- Black or Polished finish for supercharger, bracket, intercooler
- Helical gearset for noise reduction (P-1SC-1, P-1X, D-1SC, D-1X)
- Tuner Kits allow for P-1X, D-1SC, and up to F-1A-94 upgrades
- Race blow-off valve
- Race intercooler upgrade (from HO intercooler)

Call for 2021+ Grand Cherokee

2006-2010 GRAND CHEROKEE SRT8 6.1L

Jeep

2006-2010 Jeep Grand Cherokee SRT8

ProCharger's 2006-2010 SRT8 Jeep Grand Cherokee system has been a great addition to the most diverse line of superchargers and supercharger systems on the planet. High Output Intercooled Systems and Tuner Kits are available, building on the already solid statistics for the SRT8. They feature an ultra-effective air-to-air intercooler and upgradability that is hands down the best in the industry. With power gains of 160+ HP on 7 psi, the torque and acceleration numbers are nothing short of amazing.

HO Intercooled System

- The Industry's coolest charge air temperatures and largest power gains
- ProCharger P-1SC-1, 3-year warranty available
- ProCharger's patented, self-contained oiling design requires no external oil lines
- 6-rib shared drive bracket system
- 825 HP capacity air-to-air intercooler, 3-year standard warranty
- ProFlow blow-off valve
- Includes fuel injectors and tuning

Stage II Intercooled System

- 8-rib dedicated drive bracket system
- Otherwise identical to HO Intercooled System

HO / Stage II Intercooled Tuner Kits

- Omits tuning and fuel system components
- Otherwise identical to HO / Stage II Intercooled System

Optional Upgrades Include:

- Black or Polished finish for supercharger and/or bracket
- Helical gerset for noise reduction (P-1SC-1, P-1X, D-1SC, D-1X)
- Tuner Kits allow for P-1X, D-1SC, and up to F-1A-94 upgrades
- Race blow-off valve
- 1100 HP capacity Race air-to-air intercooler

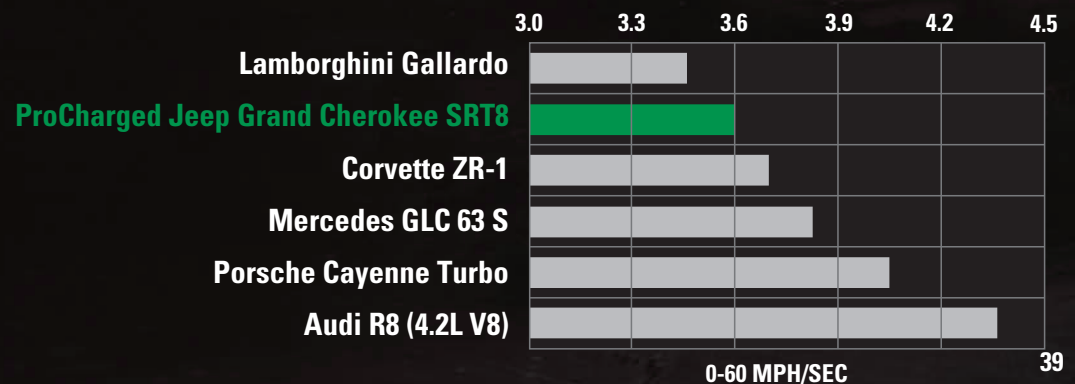



2016-2023 TACOMA 3.5L



2016-2023 Tacoma

Whether freshly washed or covered in dirt, adding a ProCharger to your Tacoma can help you achieve that added fuel-efficient power you want on the road, and the durable, linear power you want on the trail. The High Output Intercooled System features up to a 45% gain in power from a reliable and safe 8 psi of intercooled boost. This industry-leading system is designed with durability in mind for years of trouble-free use.

HO Intercooled System

- Produces the coolest charge air temps and largest power gains
- Provides boost/power on demand, for superior on-road and off-road performance
- Easiest installation, only requiring common hand tools
- Air-to-air intercooling provides consistent, reliable power, even in extreme conditions
- Optional intercooler available for winch and aftermarket bumper installations
- Optimized supercharger and intercooler location minimizes heat transfer
- Retains the factory intake manifold

HO Intercooled Tuner Kits

- Omits tuning and fuel system components
- Otherwise identical to HO Intercooled System

Optional Upgrades Include:

- Black or Polished finish for supercharger and bracket finish
- Black intercooler finish (raw finish standard)
- Helical gearset for noise reduction
- Intercooler option for aftermarket bumper and/or winch setup



CALL FOR TUNDRA 5.7L INFO

“With the predictability of the power curve of the ProCharger, keeping traction was really important and that is the behavior of that supercharger itself [versus a roots style supercharger]”

- Dwight H., @mtnyotas



**2005-2015
TACOMA 4.0L**



2005-2015 Tacoma 4.0L

ProCharger technology delivers industry-leading 40-45% power gains for Tacomas, as well the quickest and easiest installation. With highly effective air-to-air intercooling and the efficient D-1SC ProCharger, together with optimal mounting locations for both supercharger and intercooler to avoid heat soak, ProCharger delivers that much needed boost in performance. The HO Intercooled System is designed with durability in mind and provides 8 psi of engine friendly boost, for years of trouble-free use. The dedicated belt drive helps provide optimal efficiency and durability.

HO Intercooled System

- Provides power/boost on demand for on or off-road use
- Stress-free bolt-on installation only requiring basic hand tools
- Produces the coolest charge air temps and industry leading power gains
- Front mounted air-to-air intercooler provides consistent, reliable power and eliminates the complexity and heat associated with an air-to-water system
- Optimized supercharger mounting location designed to mitigate heat soak, while still retaining the factory intake manifold



HO Intercooled Tuner Kits

- Omits tuning and fuel system components
- Otherwise identical to HO Intercooled System

Optional Upgrades Include:

- Black or Polished finish for supercharger and bracket
- Black intercooler finish (raw finish standard)
- Helical gearset for noise reduction
- Intercooler option for aftermarket bumper and/or winch setup



CALL FOR TUNDRA 5.7L INFO



2010-2022 4RUNNER 4.0L



2010-2022 4Runner

ProCharger technology delivers industry-leading 40-45% power gains for Toyota owners, as well the quickest and easiest installation. With highly effective air-to-air intercooling and the efficient D-1SC ProCharger, together with optimal mounting locations for both supercharger and intercooler to avoid heat soak, ProCharger Systems and Kits are designed to give you that much needed boost in performance. The HO Intercooled System is designed with durability in mind and provides 8 psi of engine friendly boost, for years of trouble-free use. The dedicated belt drive provides maximum power transfer from the engine to the supercharger, giving you increased efficiency and durability.

HO Intercooled System

- Produces the coolest charge air temps and largest power gains
- On demand boost/power perfect for on-road and off-road performance
- Easiest installation, only requiring common hand tools
- Utilizes factory airbox and filter - Making fitment to a snorkel a breeze
- Air-to-air Intercooling provides consistent, reliable power, even in extreme conditions
- Optimized supercharger and intercooler location minimizes heat transfer
- Retains the factory intake manifold

HO Intercooled Tuner Kits

- Omits tuning and fuel system components
- Otherwise identical to HO Intercooled System

Optional Upgrades Include:

- Black or Polished finish for supercharger and bracket
- Black intercooler finish (raw finish standard)
- Helical gearset for noise reduction
- ProCharger engine cover (Raw or Black finish optional)
- Optional intercooler available for winch and aftermarket bumper installations



Optional engine cover & black supercharger finish shown



Optional polish supercharger finish shown



"A legacy built on POWER, RELIABILITY, DRIVABILITY, WINNING, & INNOVATION. The worlds most powerful superchargers"

- ProCharger Superchargers



OFF-ROAD PERFORMANCE

While new vehicle manufacturers continue to improve and evolve their truck and SUV offerings, ProCharger is hard at work behind the scenes to offer supercharger systems to greatly improve the power on everything from your daily driver to more hard-core off-road vehicle. Whether your truck or SUV is a street-bound vehicle with bigger wheels and tires or heavily modified for more serious off-road activities, ProCharger has a supercharger system to accomplish your goals.

With 30 years of experience, ProCharger has developed a lot of kits for nearly all off-road applications, from mild 400 horsepower rigs all the way up to the most extreme, heavily modified builds that desire a whopping 4,000+ HP! ProCharger has the broadest and most well-engineered offering of supercharger kits to make fitment easier for custom applications, and ensure you are receiving the largest power gains and greatest durability available.

For leisurely weekend off-road and camping adventures with your family and friends to building a dedicated custom rig meant for extreme events like hard core desert racing or the annual King of the Hammers event, ProCharger's industry-leading technology will provide you with the coolest and most efficient horsepower increase you'll find anywhere.



RACING DOMINATION

REAL WORLD PROCHARGER POWER

“[ProCharger is] leading the charts across the board in a multitude of different sanctions and series, setting records, breaking hearts...”

- Wes Buck, Drag Illustrated

ProCharger Motorsports

ProCharger has a long 30 year history of helping an incredible number of enthusiasts and racers accomplish their performance goals: WINNING! From drag strips to off-road, and from the salt flats of Bonneville to open road races and rear-wheel dyno competitions, more and more ProCharger owners are reaching and exceeding their performance goals in amazing fashion.

When it comes to motorsports, talk is cheap. It seems like there are always too many aftermarket manufacturers willing to inflate their performance claims. ProCharger-equipped racers prefer to let their actions and results speak for themselves.

ProCharger and Racing: A Winning Combination

ProCharger superchargers are synonymous with high performance, especially in sanctioned drag racing competition. ProCharger was the first centrifugal supercharger to power racers into the 6's. As a matter of fact, as far back as 2002, every single Super Street and Street Outlaw racer in the 7's, and Renegade racer in the 8's were all ProCharged. Once the ProCharger supercharger power genie was out of the bottle, there was no looking back—unless you count looking in the mirror for the other guys.

The list of ProCharged racing champions, record holders and top performers reads like a Who's Who of winning racers. No one else even comes close, as ProCharged racers have won over 250 national championships in the past 20 years, more than all of our direct competitors combined.

We Race, You Win

The same design philosophy that puts top racers into the winner's circle can be found in every street-legal ProCharger supercharger system. With a ProCharger system, not only will you receive the largest and most engine-friendly horsepower gains, you also have the peace of mind knowing that your supercharger was designed to reliably and consistently produce event and championship-winning power race after race, year after year. What are your high-performance goals? Let ProCharger help you blow them away.



A daily driven 2017 GMC Sierra powered by a Stage II ProCharger kit with an F-1X. The full-weight truck runs low 9's at 140+ mph in the quarter-mile and this truck drives to the track, with the slicks in the bed.

Consider these ProCharger Motorsports Achievements:

- ProCharged racers have won over 250 national championships in the past 20 years
- The ONLY supercharger to run 3.40's in 1/8th mile and 5.30's in 1/4 mile (at over 269mph)
- The ONLY centrifugal supercharger to make 4,000 horsepower on methanol
- In drag racing, the 80 quickest centrifugal racers are all powered by ProCharger
- HOT ROD Pump Gas Drags Championship, HOT ROD Drag Week Championship, and Maxton Mile Top Speed Challenge Winner
- First and only centrifugal approved for NHRA Pro Mod

F-SERIES

1,050 - 4,500+ HP

ProCharger F-Series Superchargers

ProCharger F-Series superchargers were designed with one simple goal: blow the competition away. Since their introduction in 2000, ProCharger's ever-expanding lineup of F-Series superchargers have continued to be the standard by which others hope to be measured, both on the track and on the street. From the custom designed 7075 billet aluminum impeller to the CNC machined transmission case to the industry-exclusive, compound bearing design, each self-contained F-Series supercharger has been designed to deliver maximum performance, pass after pass, year after year, championship after championship.

F-1, F-1D, F-1A, and F-1A-94

These ProCharger superchargers utilize a compact, 9" volute and are powerful and highly versatile superchargers. Like all the F-Series models, the F-1 and F-1A feature the industry-exclusive compound bearing design that supports high horsepower applications, while the patented and proven self-contained oiling design eliminates the need for external oil lines while providing years and years of trouble-free high performance.

F-1C and F-1R

These two ProCharger superchargers use a slightly larger, 9.75" volute for higher airflow and HP ratings and retain all the design advantages of the other F-Series models.

F-2, F-3, and F-4 Models

Higher horsepower means higher airflow and bigger boost. Enter the F-2, F-3, and F-4 ProCharger models, with their industry-leading performance and durability. To learn more, visit procharger.com or call the ProCharger Sales Team at (913) 338-2886.



F-1D

Base HP (NA Engine) ...300-500 HP
Max Supercharged HP....1,050 HP
Maximum Airflow1,500 cfm
Maximum Boost..... 34 psi
Maximum Impeller RPM65,000
Internal Step-up Ratio 5.40:1

F-1A

Base HP (NA Engine) ...300-500 HP
Max Supercharged HP....1,100 HP
Maximum Airflow1,575 cfm
Maximum Boost..... 38 psi
Maximum Impeller RPM74,000
Internal Step-up Ratio 5.40:1

F-1X

The ProCharger F-1X features a 10.5 inch volute diameter and provides a significant increase in airflow when compared with the 9 inch and 9.75 inch ProChargers. Considered by many to be the ideal combination of small size and high performance, the F-1X can support up to 1,400+HP.

F-1A-91

Base HP (NA Engine) ...300-500 HP
Max Supercharged HP.... 1,200 HP
Maximum Airflow1,600 cfm
Maximum Boost..... 38 psi
Maximum Impeller RPM74,000
Internal Step-up Ratio 5.40:1

F-1C

Base HP (NA Engine) ...300-550 HP
Max Supercharged HP....1,100 HP
Maximum Airflow1,625 cfm
Maximum Boost..... 38 psi
Maximum Impeller RPM74,000
Internal Step-up Ratio 5.40:1

F-1A-94

Base HP (NA Engine) ...300-500 HP
Max Supercharged HP.... 1,300 HP
Maximum Airflow1,625 cfm
Maximum Boost..... 38 psi
Maximum Impeller RPM74,000
Internal Step-up Ratio 5.40:1

F-1R

Base HP (NA Engine) ...375-550 HP
Max Supercharged HP.... 1,250 HP
Maximum Airflow1,700 cfm
Maximum Boost..... 38 psi
Maximum Impeller RPM68,000
Internal Step-up Ratio 5.40:1

F-1X

Base HP (NA Engine) ...375-550 HP
Max Supercharged HP.... 1,400 HP
Maximum Airflow 2,000 cfm
Maximum Boost..... 38 psi
Maximum Impeller RPM72,000
Internal Step-up Ratio 5.40:1

“The normal, closed loop air-to-water intercooler system [not using ice] is **not as effective as a properly designed air-to-air intercooling system** since the cooling medium or the liquid coming from the front heat exchanger is always warmer than the ambient air temperature.” – *“All About Intercooling”, George Spears*



INVENTED, ENGINEERED



AND MADE IN THE USA

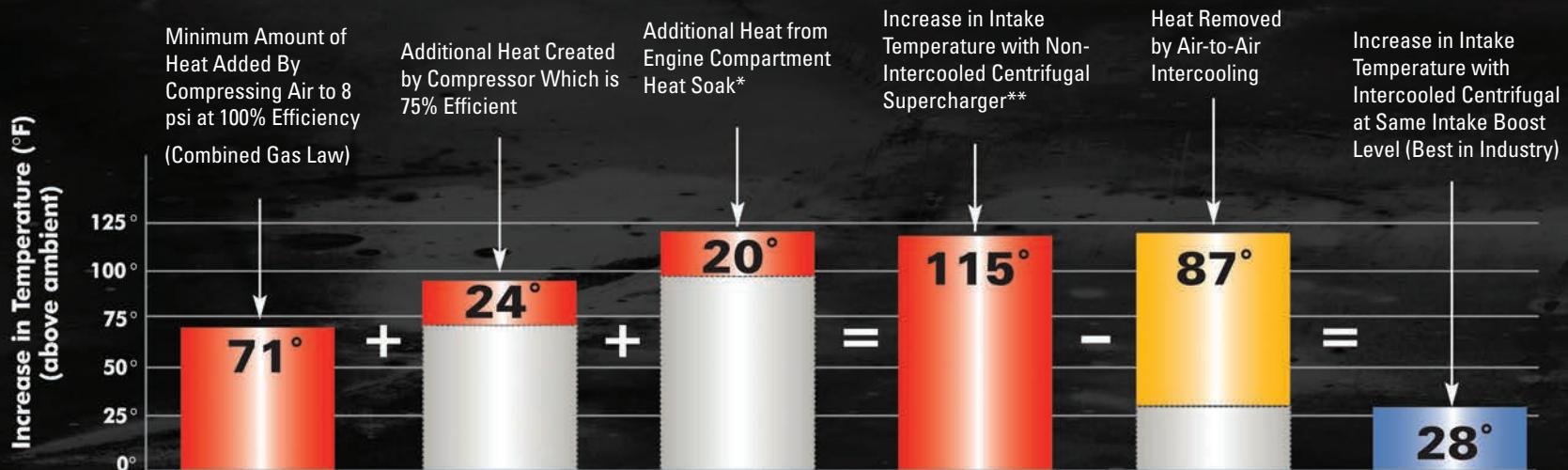

*Radiant heat from engine and exhaust transferred through air, conductive heat transferred directly, and convective heat from engine oil. This engine compartment heat is not addressed by SAE J1723 (supercharger efficiency standard). ** Temperature will be higher for PD blower or turbo.

CENTRIFUGAL SUPERCHARGING

FIRST TO MARKET: SELF-CONTAINED GEAR-DRIVEN SYSTEMS

Supercharger Efficiency

A supercharger is a device for increasing the air volume of an internal combustion engine over that which would normally be drawn in by the intake stroke of the pistons. Efficiency refers to both the heat created by the supercharger and the power required to drive it.

Today, there are two different types of superchargers being offered by the performance industry:

- Centrifugal superchargers
- Positive-displacement blowers (PD)

Due to their specific design, centrifugal compressors can be much more efficient than positive displacement superchargers. More efficient compressors mean more efficient supercharger systems. Centrifugals also allow the use of air-to-air intercooling, which is superior to air-to-water. This is the very core of the ProCharger advantage.

The advantages are in terms of airflow and air pressure, and as a result, centrifugal compressors produce greater power and significantly lower charge air temperatures. Centrifugals also feature a broad operating range which supports future engine modifications, meaning you are less likely to “outgrow” your ProCharger supercharger than a positive displacement design.

Efficiency is a large ProCharger advantage, with typical ProCharger efficiencies of 70-78% vs typical PD efficiencies of 60-70% at lower boost levels. At higher boost levels, ProCharger and other centrifugals maintain their high efficiency, while PD efficiencies decline and become even more disadvantaged. This is because air “slippage” past the PD rotors increases as pressure rises, reducing PD blower efficiency. This is in addition to the negative effect of heat soak, which also increases as pressure rises, further reducing real world PD efficiency.

More Sustainable Torque

Thanks to the industry’s coolest charge air temperatures and lowest exhaust gas temperatures, Intercooled ProCharger Systems have a much higher detonation threshold (less potential for detonation) than intercooled positive displacement superchargers and turbochargers. ProCharger is not only able to produce a large increase in torque, but more importantly sustain that increase in torque for longer than other power adders. This means that ProCharger is able to deliver power and torque when you need it most, without sacrificing engine longevity. And when compared to forced induction systems without intercooling, the ProCharger advantage is even greater.

A ProCharger centrifugal supercharger can also support future modifications to your engine or exhaust system. High-flow intake manifolds, camshaft, cylinder heads and exhaust systems can all be supported via more airflow and boost from the same ProCharger supercharger with a simple pulley upgrade.



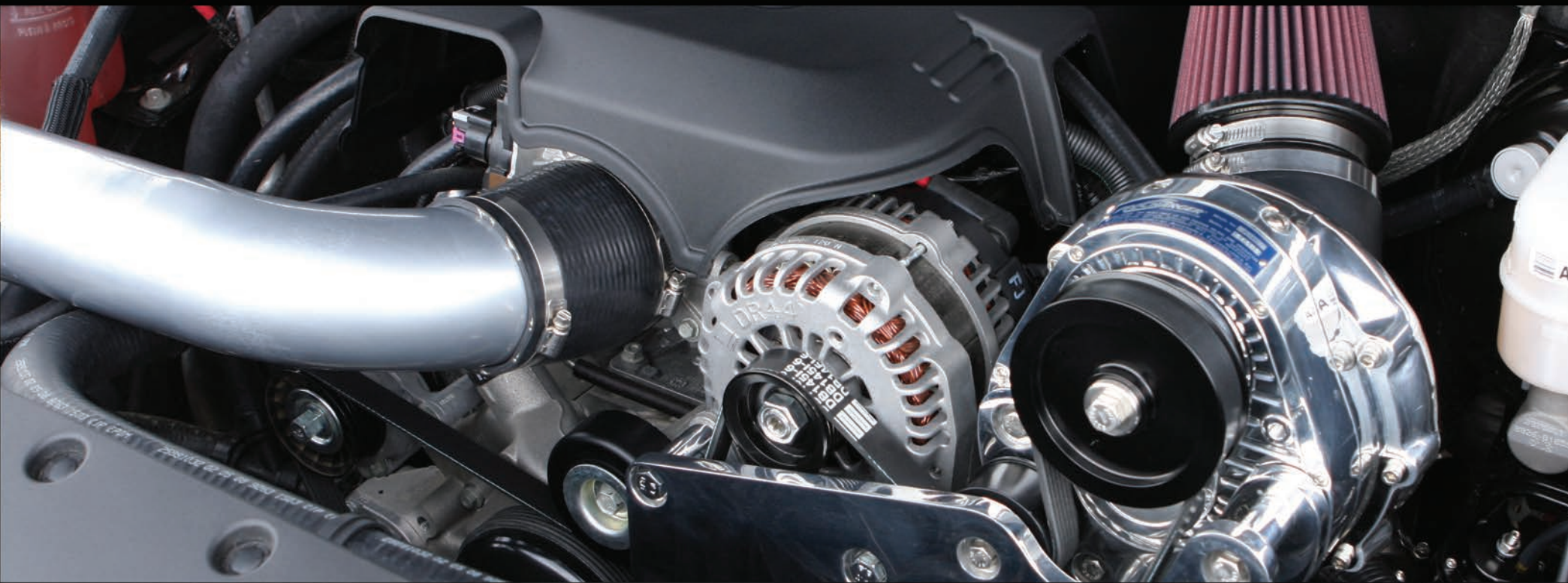

ADVANTAGE IN EFFICIENCY AND OPERATING RANGE

HIGH-EFFICIENCY
CENTRIFUGAL SUPERCHARGER

TYPICAL POSITIVE
DISPLACEMENT BLOWER

PRESSURE ↑

0 AIRFLOW →

“With plenty of visceral grunt, an aspect of civility, and practicality thrown in for good measure, centrifugal blowers are perhaps one of the **best investments you can make** when purchasing a power adder.”
—GM High Tech Performance

Wider Operating Range

Centrifugal superchargers have a much broader operating range, in terms of both airflow and pressure, when compared to typical positive displacement blowers. Thus centrifugals deliver not only the best dollar per horsepower ratio upfront, but also protect your investment by decreasing the likelihood of outgrowing your supercharger.

CENTRIFUGAL THERMAL ADVANTAGE

LESS HEAT MEANS MORE POWER AND GREATER RELIABILITY

Thermal Advantage

It's really quite simple: cooler air is more dense. Denser air is able to produce more power. If your goal is to produce maximum reliable power, then you need the coolest charge air temperatures possible. When it comes to producing consistent and reliable power, heat is the enemy.

These images illustrate the thermal advantages of a ProCharger Supercharger System when compared with a turbocharger and positive displacement blower. By their very design, centrifugal superchargers are more efficient compressors and create less heat during their operation. Additionally, ProCharger superchargers are mounted away from the engine, which is a much cooler environment than on top of the engine.

Turbochargers require hot engine exhaust to compress air. The result is a very hot turbine and turbine housing which transfers heat to the compressor. Turbochargers also create high exhaust gas temperatures and back pressure, causing additional heat build up in exhaust manifolds, cylinder heads and valves.

Positive-displacement (PD) blowers are typically located directly on top of the engine or deep between the cylinder heads. Because they are attached to or surrounded by hot engine components, this is an extremely hot environment. The location of a PD blower prevents the use of air-to-air intercooling, and necessitates the use of less effective air-to-water intercooling, also located in a very heat soaked environment.

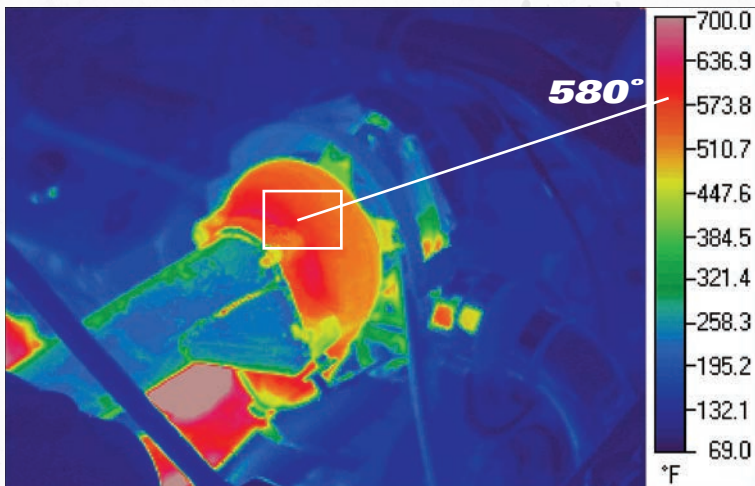

Turbocharger

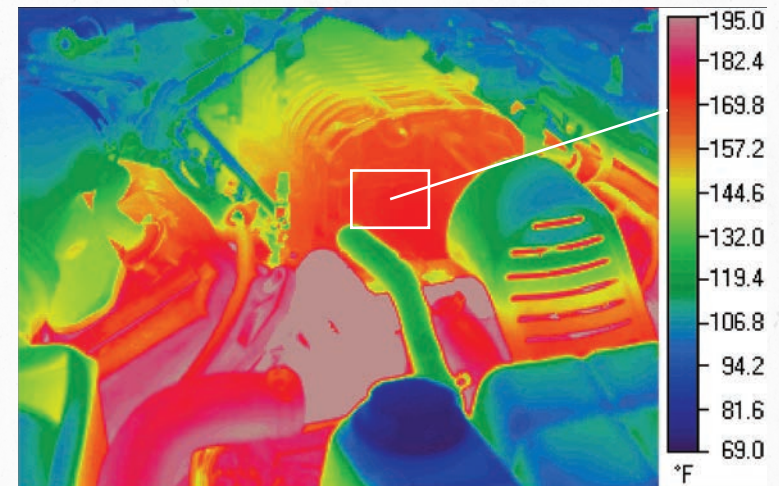

Positive displacement with air-to-water-to-air intercooler, 8 psi

Note: scales of turbocharger and positive displacement images are higher due to the additional heat they produce

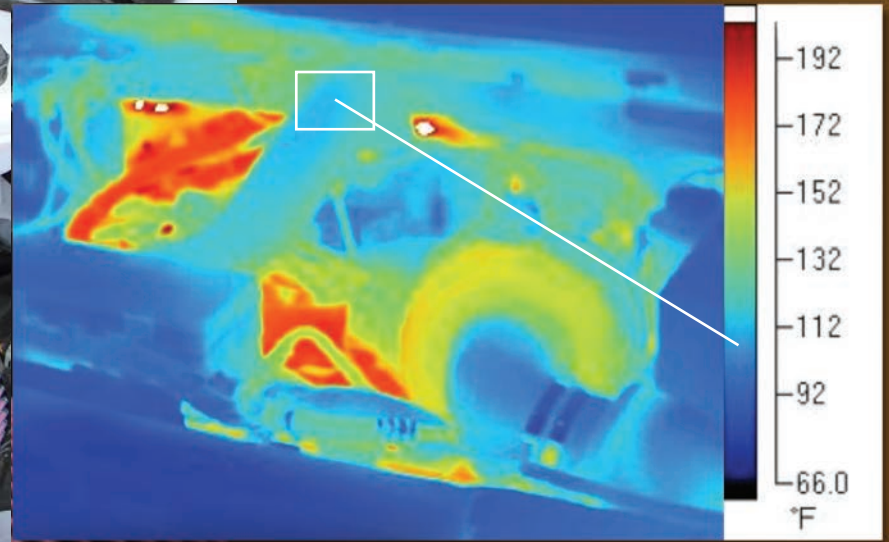

Intercooled ProCharger, 8 psi

Increase in Charge Air Temperatures at Engine Intake (8 psi, °F)

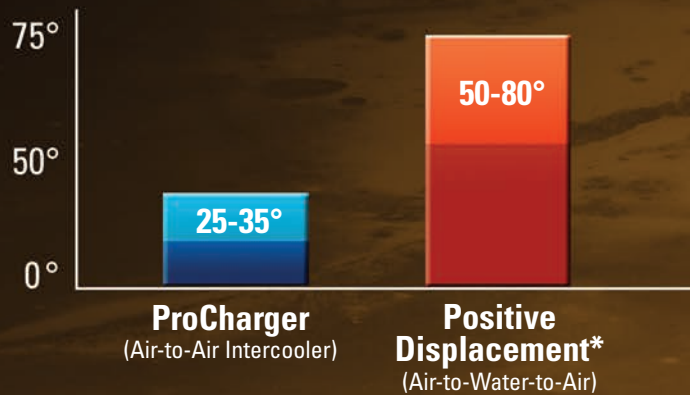

*Aftermarket intercoolers; range dependent on manufacturer, vehicle application and pressure ratio

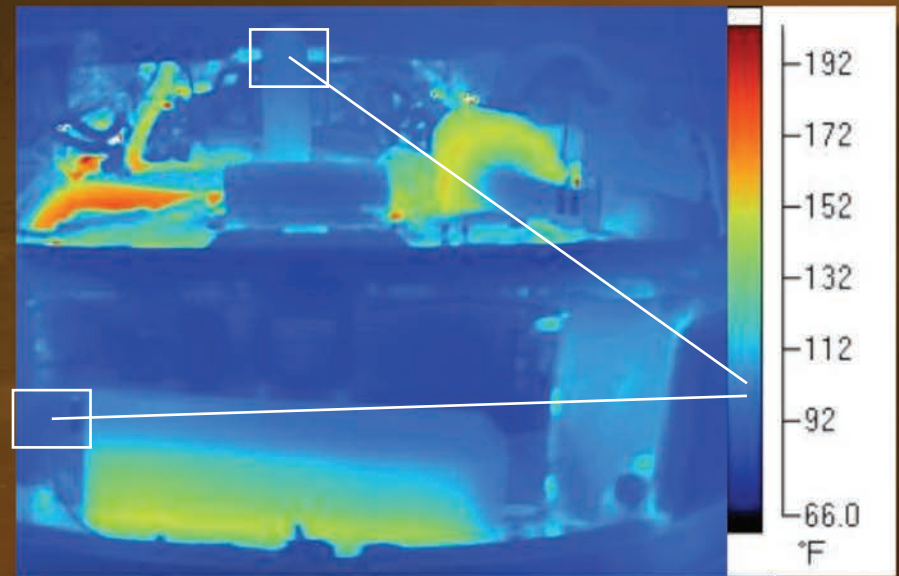

ProCharger & Air-to-Air Intercooler

THE ULTIMATE POWER ADDER®

NOTHING ELSE EVEN COMES CLOSE

Other Power Adders Just Don't Add Up

Proven by truck owners around the world, no other form of aftermarket power-adder provides the combination of power, reliability, ease of installation and maintenance, engine safety and cool operation of a ProCharger. Let's take a look at why the other power enhancing options just don't add up.

Positive Displacement Blowers

Centrifugal superchargers offer substantially higher adiabatic efficiencies than their positive-displacement (PD) counterparts. PD blowers are located on top or nestled in the "V" of the engine, placing them in a very hot, harsh environment which results in significantly hotter charge air temperatures. This location also forces the use of a more complex and less effective air-to-water-to-air intercooling configuration. To cope with these high charge air temperatures, PD blowers must be tuned rich with less timing. This reduces the vehicle's fuel economy, driveability, power and engine longevity.

Turbochargers

Although they use advanced compressor technologies similar to ProCharger's compressor designs, turbo systems' initial cost and complexity make them less practical for everyday street driving. Because a turbo relies on hot engine exhaust to create power, they also create high exhaust temperatures and back pressure, high charge air temperatures and are subject to "lag" that degrades their real-world driving performance. Additionally, turbos require engine oil feed and return lines for lubrication and due to extreme heat, increase the thermal breakdown of your engine's oil.

Nitrous Oxide

Nitrous oxide accelerates the combustion rate, which in turn, increases peak cylinder pressures. While it may increase pressures, it is inconsistent and difficult to control with precision. This combination greatly increases the probability of piston-melting pre-detonation. The rapid increase of cylinder pressure also increases the load placed on internal engine components potentially leading to catastrophic failure.



Naturally Aspirated

The expense and time to build a naturally aspirated engine large enough to produce a power level even close to a ProCharged engine just doesn't add up - especially when you consider the poor idle quality and extra fuel the naturally aspirated engine will require. When compared to a ProCharged engine of similar performance, a naturally aspirated high horsepower engine will require far larger displacement, higher compression, expensive components and an aggressive cam. You must also consider the time and hassle of a complete engine swap or the downtime of a complete engine rebuild.

"Overall, air/liquid systems are more complex, since a circulating pump and front air exchanger are necessary and they are heavier than an air-to-air unit of equal cooling capacity."
– "All About Intercooling", George Spears



"You can drive this thing every day and never even know it's [ProCharger] on there until you step on the pedal, and you'll still get good gas mileage."

- Stacey David, Gearz TV

POWER ADDER COMPARISON

Comparison for Making 575-600+ HP When Starting With a Stock 6.2L Engine

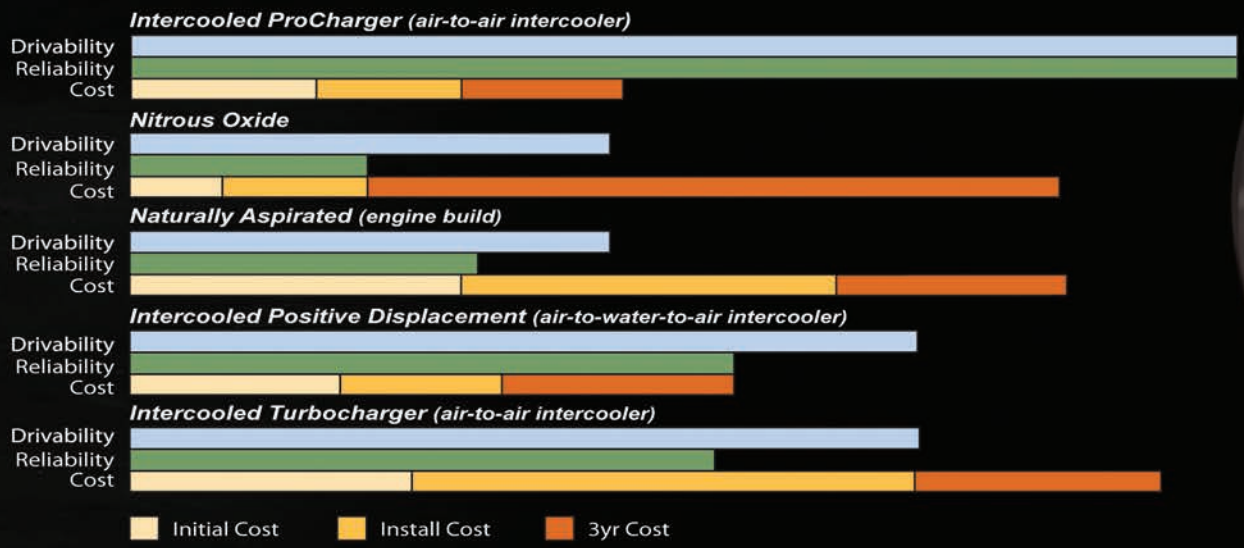

Watch 3-D Video

BUILDING THE POWER

THE LARGEST POWER GAINS IN THE INDUSTRY FROM THE GROUP UP

ProCharger: Fundamental Advantage

ProCharger has several advantages which help support cutting edge innovation, precise engineering, quality manufacturing, unsurpassed performance and best in class service. First, ProCharger designs and manufactures both its own superchargers and complete supercharger systems, unlike some competitors who buy superchargers and components elsewhere and are really only assembling kits. This helps ensure that ProCharger delivers a high quality, high performance product designed specifically for your needs. Secondly, ProCharger resources lead the industry, including best in class aerodynamic design capabilities, and an unmatched commitment to testing (test lab, chassis and engine dynos, industry's largest test fleet). No other aftermarket company is even close to ProCharger's ability to rapidly design, prototype and test new compressor models. Lastly, from the engineering group to the production team, from the sales and service staff to the shipping department, ProCharger is comprised of enthusiasts who share your passion for high performance.

These advantages, together with 30 years of experience, help to explain why ProCharger leads the supercharging industry in patents and documented performance gains—as well as more records and championships in the past 10 years than all of our direct competitors combined.

Exclusive Billet Impellers

Using state-of-the-art, five-axis CNC machines, ProCharger's proprietary impeller designs are crafted from aircraft-grade 7075 T-6 aluminum alloy for tremendous strength and performance. This top-tier material allows for larger impellers that weigh less, are free of the flaws found in typical cast impellers, and reliably produce more power. Additionally, the precision bearings used in ProCharger superchargers are of consistently higher-quality and carry higher load ratings than those used by others.



The ProCharger Campus

Made in the USA: From concept to finished product, all ProCharger Supercharger Systems are designed, tested and manufactured inside these state-of-the-art facilities.

“ProCharger takes pride in this kit being designed and manufactured in the U.S. of A.” – GM High-Tech Performance



INVENTED, ENGINEERED



AND MADE IN THE USA

LEADERSHIP THROUGH INNOVATION

ENGINEERED QUALITY AND PERFORMANCE

State-of-the-Art Test Facility

ProCharger's aerodynamics test lab utilizes state-of-the-art equipment and 3 separate test cells to help ensure that ProCharger superchargers are the best available. This test lab, the industry's largest and most capable, allows ProCharger engineers to simultaneously perform aerodynamic, gear case, and long term durability testing. A hallmark of the company's success has been a thorough understanding of engine dynamics and customer usage on the street, off road, and at the track. This helps ensure that testing in the lab, on the dyno and on the pavement are all representative of real world performance. Additionally, knowledge transferred from Inovair, Accessible Technology's industrial products division which features gear cases designed for nonstop 24/7 operation and compressor efficiencies exceeding 80%, now helps fuel further advances for ProCharger superchargers.

Billet Gear Cases

ProCharger designs and manufactures the centrifugal supercharger industry's only billet gear cases for superior rigidity, durability, sealing and appearance. This helps to support higher boost level and superior overall performance relative to other superchargers, as well as improved performance. Billet gear cases cost more than castings, but are representative of ProCharger's commitment to quality and high performance. Billet is also utilized for brackets, crank pulleys and other components.



Test lab, building #2 of ProCharger campus



Chassis dyno (1 of 2), building #3

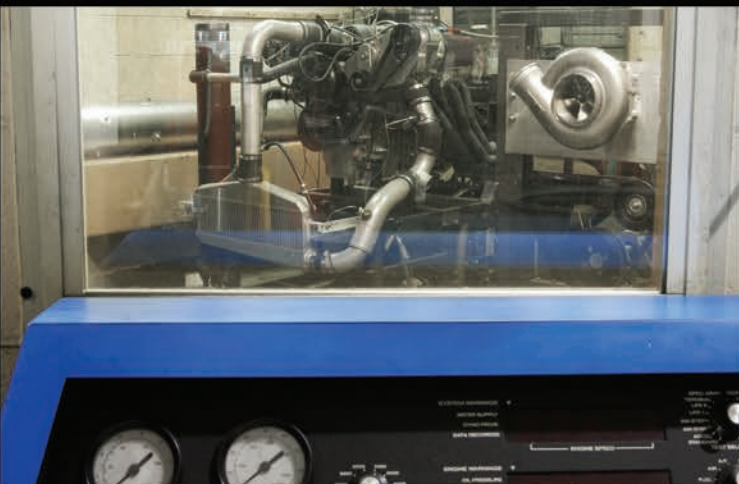

Engine dynos, building #1

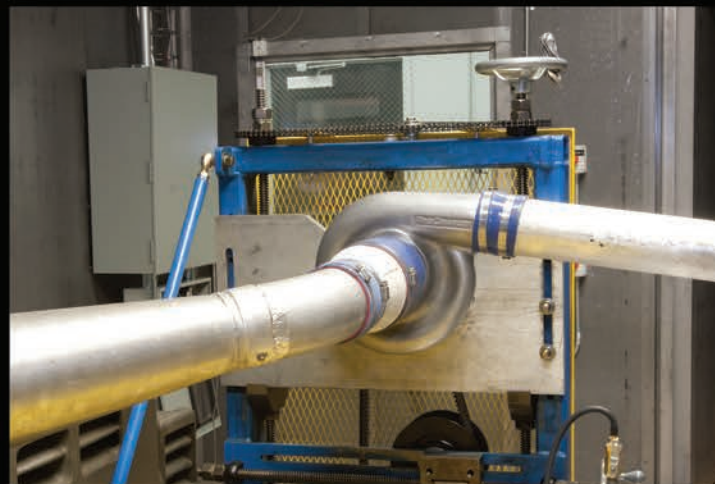

Aerodynamic test station, (1 of 6) in lab, building #2



SHOW, GO, & TOW

PLAY HARD, WORK HARD

Overlanding.

Are you hauling your race car to the track or dragstrip? Pulling a fifth wheel trailer, exploring the trails or heading out for a weekend adventure?

Towing.

Maybe a lifted show truck is your thing, or a high horsepower street custom riding low. No matter if you rely on it to make a living or own it for pure pleasure and desire, ProCharger has something for you.

Show Truck.

One thing is for sure, it's your truck and you won't settle for anything less than the best. Let ProCharger introduce you to the intercooled system for your American made truck or SUV.

Race Truck.

Utilizing the best materials, made and assembled in the heartland by skilled American workers, ProCharger is able to bring you the best bolt-on power in the industry, hands down. ProCharger: the power to show, go, and tow.

Let ProCharger bring you the best bolt-on power in the industry. Utilizing the best materials, made and assembled in the heartland by skilled American workers, ProCharger has optimized solutions to help you show, go, and tow.



UNMATCHED POWER

WORD ON THE STREET



“By using an air-to-air system, more boost can be applied to the motor without fear of detonation.”
– *Truckin’*

“Bolting on the ProCharger also increased our gas mileage.”
– *Sport Truck*

“The best part is, though; an average gearhead can put this on in just a few hours.”
– *Stacey David, Gearz TV*

“For our test, we employed the help of ProCharger, a name well known to the power game and to admiring fans. Total Gain: 169.15 rear wheel horsepower [stock 6.2L Raptor]”
– *Truckin’*

“The driveability of the system was tested when we loaded down the truck with a 7,000 pound boat and trailer and a bed full of weekend boating gear, and traveled a couple of hundred miles over hilly highway toward The Lake of the Ozarks in humid 85-degree weather. Even under boost conditions, as the truck effortlessly pulled the weight up long hills for long periods of time, the engine’s coolant temperature never surpassed normal operating temperatures.”
– *Sport Truck*

“The intercooled ProCharger centrifugal supercharger system [modified 4.6L engine with F-1A] served up an astonishing 962.6 lb-ft of torque.”
– *Motor Trend*

“Intercooled supercharging results in less stress on engine parts, lower engine temperatures [relative to other forms of high performance] and better fuel mileage”
– *Sport Truck*

“ProCharger supercharger systems feature easy installation, minimal relocation of components, no need for external oil feed or return lines, and avoid having to deal with the complexity and maintenance issues of an air-to-water-to-air intercooler configuration”
– *Street Trucks*

“This combination allows the engine to create a tire-shredding 540 rear-wheel hp and a stump-pulling 480 lb/ft of torque.” [Stock LS1 Long Block, LS6 intake, E85]
– *GM High-Tech Performance*

“A polished ATI ProCharger supercharger sends Madillac down the road in a hurry. Looks and performance make this engine compartment just one more unbelievable part of this Tahoe’s custom equation”
– *Truckin’*

“Just one romp of the throttle from a standstill, it becomes quite clear that the centrifugal blower is every bit the equal of a roots blower when it comes to low-end grunt”
– *Popular Hot Rodding*

“These intercooled ProCharger systems provide reliable 60-90 percent gains in hp and torque on pump gas, with significantly better engine reliability than is possible when supercharging without an intercooler.”
– *Sport Truck*

“Everything that you would expect from a ProCharger supercharger was delivered to us in spades. Time spent working [on installation]: 5 1/2 hours. Degree of difficulty: Intermediate.”
– *Truckin’*

PROVEN HISTORY

TIMELINE OF POWER

1 9 9 4 - 9 6



ProCharger introduces the first air-to-air intercooled aftermarket supercharger system, featuring the P600 ProCharger supercharger.

The first blow-through centrifugal supercharger kit for carbureted Chevy muscle cars and classic trucks is debuted by ProCharger.

State-of-the-art, CNC-machined billet impellers, a ProCharger exclusive, are introduced with the P600B. Designed for use with big blocks and intercooling, the P600B outflows other street-legal models by more than 65%.



ProCharger is the first centrifugal supercharger manufacturer to successfully supercharge marine engines and is also the first to offer integrated intercooling.

1 9 9 7 - 9 9



ATI / ProCharger moves into their own, newly-constructed, state-of-the-art manufacturing facility. The new location serves as engineering, R&D, technical service, customer service and marketing headquarters, leading to a period of unprecedented product expansion.



ProCharger introduces the first intercooled supercharger system for a GM truck, nearly five years before others, substantially raising the bar for performance and engine longevity.

This vehicle is equipped with an Intercooled ProCharger system with ProCharger model:

P600B
Legal for sale and installation in California
CARB Executive Order D-365
PREMIUM FUEL REQUIRED



Accessible Technologies, Inc., 14001 W. 114th Terrace, Lenexa, KS 66215 (913) 338-2886

An Intercooled ProCharger System is the first to become 50 state legal with more than 8 psi of boost.

2 0 0 0

The first self-contained, gear-driven supercharger, the P-1SC, is produced by ProCharger. The patented design requires no external oil lines and becomes the industry standard.



An industrial customer uses a D-1 ProCharger to win a U.S. Air Force contract for an aircraft deicing system which utilizes forced air.



The all-new ProCharger F-Series superchargers (above) dominate racing. Jim Summers becomes the first Pro 5.0L racer to run 7.20's with a stunning 7.26 @ 193 mph and later joins the ProCharger staff in 2002.



2 0 0 1 - 0 2



Self-contained ProChargers generate 2,000+ hp on 400 cid small blocks and dominate all others at the race track.



The industry's first intercooled supercharger for a Ford truck is introduced by ProCharger, producing 60-65% power gains on 1997-2003 F-150's. Soon thereafter, ProCharger debuts the first intercooled systems available for Dodge 5.9L and 5.2L Ram trucks.



When paired with a stock 5.4L on an F-150, ProCharger produces more power than an SVT Lightning, and is featured as part of Project Sportsman on Spike TV.

2 0 0 3 - 0 4



Having outgrown their existing facility, ProCharger breaks ground on a major building expansion.



The Little Red Wagon project, appearing on Stacey David's "Trucks!" TV show, produces 55-60% power gains on a ProCharged Dodge Ram with a 5.9L Magnum.



Intercooled ProCharger systems for the 2004+ F-150 are released, delivering a ground-pounding 65% more power.

“ProCharger’s been doing this for a long time and they’ve got it dialed in.” – Stacey David, Gearz TV

2 0 0 5 - 0 6

ProCharger is first to market with an intercooled supercharger system for 2004+ Dodge HEMI 5.7L Ram trucks, applying its industry leading HEMI supercharging knowledge.



Continuing its history of the largest, most reliable power for LS motors, Intercooled ProCharger Systems debut for 2003-06 GM trucks, featuring the coolest charge air temperatures and 60-65% power gains.



Discovery Channel’s “Monster Garage” makes a powerful statement with a ProCharger, adding insane power to an Army Jeep hot rod puller.



2 0 0 7 - 0 8



After being outlawed for years, a ProCharged racer wins the first centrifugal championship in NHRA. ProChargers are now producing more than 2,500 hp with gasoline and 3,000 hp using methanol.

A ProCharger-powered Chevrolet racer wins the prestigious HOT ROD Drag Week, earning the title: Fastest Street Car in America.



With the introduction of helical gearsets for noise reduction, ProCharger becomes the first company to offer a choice of supercharger sound levels.



The Performance Product of the Year title is awarded to ProCharger for its Harley-Davidson® intercooled supercharger systems.

2 0 0 9 - 1 1

To accommodate continued growth, ProCharger expands into an adjacent facility.



ProCharger is first to market with a supercharger system for the Ford Raptor, and Truckin’ magazine documents a 200+ crankshaft HP increase on a stock 6.2L Raptor, while also praising the quick and clean installation.



A state-of-the-art aerodynamic test lab is constructed within the ProCharger campus.



2009-10 Ram ProCharger Intercooled Systems are introduced, producing industry leading power.



2 0 1 2 - 1 8



ProCharger Systems for 2012+ SRT and 2011+ 5.7L Jeep Grand Cherokee start shipping. Testing demonstrates supercar performance, with 0-60 mph in 3.6 sec.



New Intercooled Systems for 2014+ 5.0L 4V F-150’s and 2014+ GM Trucks and SUV’s produce outstanding power gains and durability, with easy installation.



ProCharger releases a rugged new Intercooled System for the 2011+ Dodge RAM Classic.



ProCharger offers the largest power gains from any supercharger system for Toyota owners.

2 0 1 9 - 2 3



ProCharger celebrates its 25th anniversary in 2019 with events in Kansas City and California.



With industry leading power gains, ProCharger is first to introduce supercharger systems for the both the Wrangler JL and the Gladiator.



ProCharger is first to offer an intercooled system for newly designed GM trucks.



With the new release of the 2021-2023 F-150 ProCharger Systems, Ford truck owners get up to 65% more power.

FOR WHATEVER MOVES YOU

STREET, STRIP, SAND & WATER... WE'VE GOT YOU COVERED



ProCharger is The **ULTIMATE** Power Adder®

As a serious truck & SUV owner, you are all about towing, hauling, performance and every-day reliability. So why settle for anything less out of the truck, SUV or any other vehicle in your garage? From four-door family sedans, to boats, sport cars, Harley-Davidson motorcycles,

high-performance UTV's and all-out race and track cars, chances are ProCharger has an intercooled supercharger solution for it. For your carbureted classic truck or muscle car, ProCharger has the largest offering of blow-through carbureted kits and options as well as LSx transplant kits. Give our sales team a call at (913) 338-2886 or visit ProCharger.com for more information.

"The real magic, of course, comes from the ProCharger centrifugal supercharger. Which specific blower model used depends on how fast you want to go." – HOT ROD Magazine



PROCHARGE YOUR LIFE

GET EQUIPPED, GET CONNECTED

ProCharger Online: Catalogs, Vehicle Gallery, Apparel, Parts and more!

Check out our website for more application-specific information about our complete line of supercharger systems, cool videos and vehicle galleries where you can create your own gallery entry with your ProCharger-powered car, truck, race car, motorcycle, ATV or boat!

While you're on the site, make sure to check out the online versions of ProCharger's industry leading, downloadable catalogs for whatever vehicle platform you have or are considering. Show your ProCharger pride with a big selection of ProCharger apparel from T-shirts, hats, license plate frames, gauges and more at ProCharger.com/store.



SCAN HERE TO SHOP THE PROCHARGER STORE NOW!



PROCHARGER[®]

SUPERCHARGER SYSTEMS

STREET OR STRIP - PROCHARGER HAS YOU COVERED WITH

THE ULTIMATE POWER ADDER[®]

All of us at ATI encourage you to use your newfound ProCharger power responsibly.
Please drive safely and be respectful of your fellow motorists. If you feel the need to race, don't do it on the street—take it to the track!

ProCharger[®] and The Ultimate Power Adder[®] are registered trademarks of Accessible Technologies, Inc. Chevy[®]/GM[®] are registered trademarks of General Motors and are used for descriptive purposes only; Ford[®] is a registered trademark of Ford Motors and is used for descriptive purposes only; Chrysler[®]/Dodge[®]/Ram[®]/Hemi[®]/Jeep[®] are registered trademarks of FCA, LLC and are used for descriptive purposes only. Toyota[®] is registered trademarks of Toyota Industries and are used for descriptive purposes only.

© Copyright 2023, Accessible Technologies, Inc. 10/23

FOLLOW US



#PROCHARGER

CALL OR EMAIL

Sales/Service Phone Hours: 8:00 am–5:30 pm CST (M-F)
Sales Email: sales@procharger.com
Technical Service Email: ts@procharger.com
Customer Service Email: cs@procharger.com



MADE IN AMERICA



14801 W. 114TH TERR LENEKA, KS 66215 • PH: (913) 338-2886 • FX: (913) 338-2879

WWW.PROCHARGER.COM

