

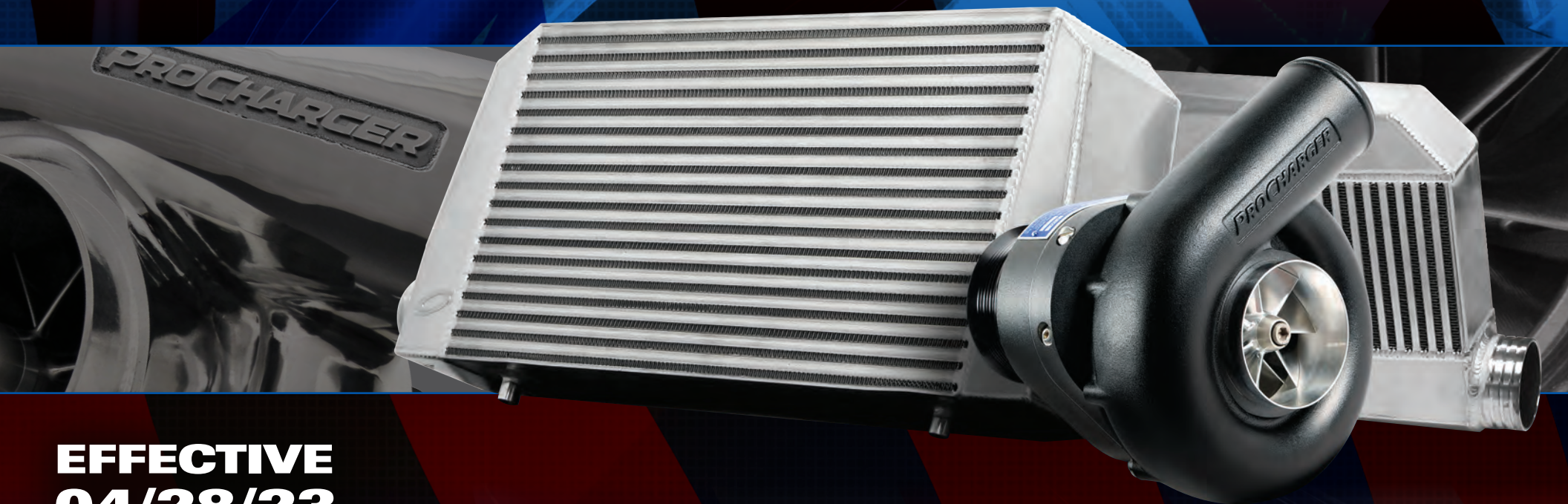

# AUTOMOTIVE & TRUCK/SUV

APPLICATIONS, SPECIFICATIONS, AND DISTRIBUTOR PRICE GUIDE



**EFFECTIVE  
04/28/23**

Supersedes all previous price lists

**CALL REGARDING 2024 MODEL YEARS**

**THE WORLD'S BEST & BROADEST  
SUPERCHARGER PRODUCT LINE**





## FORD AUTOMOTIVE

2018-23 Mustang GT (5.0 4V) . . . . .	4
2021-23 Mach 1 (5.0 4V) . . . . .	4
2018-20 Bullitt (5.0 4V) . . . . .	4
2015-20 GT350 and GT350R (5.2 4V) . . . . .	4
2015-17 Mustang GT (5.0 4V) . . . . .	6
2015-17 Mustang V6 (3.7 4V) . . . . .	6
2011-14 Mustang GT and i-1 (5.0 4V) . . . . .	8
2011-14 Mustang V6 (3.7 4V) . . . . .	8
2012-13 Boss 302 Mustang and i-1 . . . . .	10
2005-10 Mustang GT (4.6 3V) and V6 (4.0) . . . . .	12
1999-04 Mustang GT and 2001 Bullitt (4.6 2V) . . . . .	14
2003-04 Mustang Mach 1 (4.6 4V) . . . . .	14
1996-98 Mustang GT (4.6 2V) . . . . .	14
1994-04 Mustang V6 (3.8, 3.9) . . . . .	14
2003-04 Cobra (4.6 4V) . . . . .	16
1999-01 Cobra (4.6 4V) . . . . .	16
1996-98 Cobra and Race Kits (4.6 4V) . . . . .	16
1994-95 Mustang, Cobra (5.0) . . . . .	18
1986-93 Mustang, Cobra (5.0) . . . . .	18
1964½-66 Early Ford Kits (289/302) . . . . .	20
Carb/Aftermarket EFI Serpentine/Cog Race Kits . . . . .	20-22
Coyote Engine Swap (5.0 4V) Kits . . . . .	24
Godzilla Engine Swap (7.3) Kits . . . . .	24

## CHEVROLET/PONTIAC/GM AUTOMOTIVE

2020-23 Corvette C8 Coupe & <b>*NEW*</b> Convertible (LT2) . . . . .	26
2014-19 Corvette C7 Stingray/Grand Sport (LT1) . . . . .	28
2015-19 Corvette C7 Z06 (LT4), Stingray (LT1) and i-1 . . . . .	28
2008-13 Corvette C6 (LS3) and i-1 . . . . .	30
2006-13 Corvette C6 Z06 (LS7) . . . . .	30
2005-07 Corvette C6 (LS2) . . . . .	30
1997-04 Corvette C5, Z06 (LS1, LS6) . . . . .	32
1985-96 Corvette C4 (LT1, LT4, TPI L98) . . . . .	32
2016-23 Camaro SS (LT1) . . . . .	34
2017-21 Camaro ZL1 (LT4) . . . . .	34
2016-21 Camaro V6 (3.6) . . . . .	34
2016-19 Cadillac CTS-V (LT4) . . . . .	34
2014-15 Camaro Z/28 (LS7) . . . . .	36
2010-15 Camaro SS and i-1 (LS3, L99) . . . . .	36
2010-15 Camaro SS Cog Race Kits . . . . .	36
1998-02 Camaro/Firebird (LS1) . . . . .	38
1993-97 Camaro/Firebird (LT1) . . . . .	38
1987-92 Camaro/Firebird TPI (L98) . . . . .	38
2014-17 Chevrolet SS . . . . .	40
2008-09 Pontiac G8 GT . . . . .	40
2004-06 Pontiac GTO (LS1, LS2) . . . . .	40
<b>*NEW*</b> LS Serpentine Accessory Drive Kit . . . . .	42
LS Engine Swap Serpentine/Cog Race Kits . . . . .	44
Passenger Side LSx Reverse Swap Kits . . . . .	46
LT1/LT4 Engine Swap Serpentine Kits . . . . .	46
<b>*NEW*</b> SBC/BBC Serpentine Accessory Drive Kit . . . . .	48
SBC/BBC Serpentine and Cog Kits . . . . .	50-53

## DODGE/CHRYSLER AUTOMOTIVE

2011-23 Dodge Challenger HEMI (6.4) . . . . .	54
2011-23 Dodge Challenger HEMI (5.7) . . . . .	54
2015-22 Dodge Challenger V6 (3.6) . . . . .	54
2008-10 Dodge Challenger HEMI SRT8 (6.1) . . . . .	56
2008-10 Dodge Challenger HEMI R/T (5.7) . . . . .	56
2012-23 Dodge Charger HEMI SRT8 (6.4) . . . . .	58
2011-23 Dodge Charger HEMI R/T (5.7) . . . . .	58
2015-22 Dodge Charger V6 (3.6) . . . . .	58
2006-10 Dodge Charger HEMI SRT8 (6.1) . . . . .	60
2006-10 Dodge Charger HEMI R/T (5.7) . . . . .	60
2012-14 Chrysler 300 HEMI SRT8 (6.4) . . . . .	62
2011-23 Chrysler 300 HEMI (5.7) . . . . .	62
2005-10 Chrysler 300 HEMI (6.1) . . . . .	62
2005-10 Chrysler 300 HEMI (5.7) . . . . .	62
2005-08 Dodge Magnum HEMI (6.1) . . . . .	62
2005-08 Dodge Magnum HEMI (5.7) . . . . .	62

## GM TRUCK/SUV

2019-23 GM Truck 1500 (5.3, 6.2) . . . . .	64
<b>*NEW*</b> 2021-23 GM SUV (5.3, 6.2) . . . . .	64
2020-23 GM Truck 2500 (6.6) . . . . .	64
2014-18 GM Truck 1500 (5.3, 6.2) . . . . .	66
2015-20 GM SUV (5.3, 6.2) . . . . .	66
2015-19 GM Truck 2500 (6.0) . . . . .	66
2007-13 GM Truck 1500 and i-1 (4.8, 5.3, 6.0, 6.2) . . . . .	68
2007-13 GM SUV (4.8, 5.3, 6.0, 6.2) . . . . .	68
2007-13 GM Truck 2500 and i-1 (6.0) . . . . .	68
2003-07 GM Truck 1500 Classic (4.8, 5.3, 6.0) . . . . .	70
1999-07 GM Truck 2500 Classic (6.0) . . . . .	70
2003-09 Hummer H2 (6.0, 6.2) . . . . .	70
1999-03 GM Truck/SUV (4.8, 5.3, 6.0) . . . . .	70
1996-00 GM Truck/SUV (5.7, 7.4) . . . . .	72
1988-95 GM TBI Truck/SUV (5.7, 7.4) . . . . .	72

## FORD TRUCK/SUV

2020-22 Ford Super Duty (7.3) . . . . .	74
<b>*NEW*</b> 2021-23 Ford F-150 (5.0 4V) . . . . .	74
2015-20 Ford F-150 (5.0 4V) . . . . .	74
2011-14 Ford F-150 and i-1 (5.0, 6.2 4V) . . . . .	76
2010-14 Ford F-150 SVT Raptor and i-1 (5.4, 6.2 3V) . . . . .	78
2004-10 Ford F-150 and Expedition (5.4 3V) . . . . .	78
1997-03 Ford F-150 and Expedition (5.4, 4.6 2V) . . . . .	78

## DODGE/RAM TRUCK/SUV

2011-22 Ram Classic / 1500 / eTorque (5.7) . . . . .	80
2014-21 Ram 2500/3500 and Power Wagon (6.4) . . . . .	80
2018-21 Dodge Durango SRT (6.4) . . . . .	80
2009-10 Ram Classic (5.7) . . . . .	82
2004-08 Dodge Ram (5.7) . . . . .	82
1996-01 Dodge Ram (5.2, 5.9) . . . . .	82
1997-01 Dodge Dakota/Durango (5.2, 5.9) . . . . .	82

## JEEP

2012-20 Jeep Grand Cherokee SRT (6.4) . . . . .	84
2011-20 Jeep Grand Cherokee (5.7) . . . . .	84
2006-10 Jeep Grand Cherokee SRT8 (6.1) . . . . .	84
2020-22 Jeep Gladiator JT (3.6) . . . . .	84
2018-22 Jeep Wrangler JL (3.6) . . . . .	84
2012-18 Jeep Wrangler JK (3.6) . . . . .	84

## TOYOTA

2010-19 4Runner (4.0) . . . . .	86
2016-23 Tacoma (3.5) . . . . .	86
2005-15 Tacoma (4.0) . . . . .	86
2007-20 Tundra (5.7) . . . . .	86

## SPORT COMPACT

2015-19 Polaris Slingshot . . . . .	88
2003-06 Nissan 350Z (3.5) . . . . .	88
2003-04 Infiniti G35 Coupe, FX35 (3.5) . . . . .	88
1999-00 Honda Civic SI (1.6L DOHC) . . . . .	88
1994-01 Acura Integra GSR Type R (1.8L DOHC) . . . . .	88
2000-04 Ford Focus (Zetec, SVT) . . . . .	88

## GENERAL INFORMATION

Street/Strip Supercharger Specifications . . . . .	90
Race Supercharger Specifications . . . . .	91
Superchargers . . . . .	92
Parts, Accessories, & Racing Products . . . . .	93
Intercoolers for Custom Applications . . . . .	94

## CALL REGARDING 2024 MODEL YEARS



# DEFINITIONS, TERMS & CONDITIONS



EFFECTIVE DATE 04/28/23

## PROCHARGER COMPLETE SYSTEMS

- ProCharger systems are sold 100% complete unless noted otherwise.
- High Output (HO) Intercooled Systems are designed for operation on vehicles with stock engines and stock exhaust.
- Stage II Intercooled Systems are designed to accommodate higher power levels, but tuning is provided for stock vehicles only.
- Tuning is available for Systems only, and only for vehicles with stock engines with stock exhaust, as well as most “cat-back” exhaust systems.
- Boost level and performance may change based on elevation.
- Complete systems with tuning require a minimum of US 91 octane gas.
- All engine and exhaust modifications must be noted at time of order. ProCharger is not responsible for boost levels or tuning for modified applications.
- Vehicles built for export and other non-US spec vehicles may require custom tuning/calibrations.
- ProCharger systems for stock vehicles are emissions legal in all 50 states where noted in the “CARB EO” column in the product specs. For compliance information, visit [www.arb.ca.gov](http://www.arb.ca.gov)
- Due to variability among OEM computers, the prevalence of custom modifications, and age/miles/condition of vehicles, dyno tuning may be required; stock vehicles with cat-back exhaust systems may require custom tuning.

## PROCHARGER TUNER KITS

- ProCharger Tuner Kits exclude fuel components and computer programming, but are otherwise identical to complete systems.
- HO Intercooled Tuner Kits are designed for stock and modified vehicles.
- Stage II Intercooled Tuner Kits accommodate higher power levels, and are designed for both stock and modified vehicles.
- Race kits and components are intended for off-road/racing use only and may require modifications, trimming, and/or additional components.
- Tuner kits are intended to be dyno-tuned by professional tuners/installers with custom programming.

## GENERAL INFORMATION

- You must list Minimum Advertised Pricing (MAP) equal to PRICE as displayed throughout this price guide. MAP = PRICE
- All prices and specifications are subject to change without prior notification. The most recently printed price guide supersedes all previous statements of product specifications and/or pricing.
- Payment is required in advance before product may be shipped. ATI accepts payment in the form of credit card (USA only), cashier's check, certified check, wire transfers or money order. Payments made by company check, cashier's check, certified check or money order may cause shipping delays while check clears, unless prior arrangements have been made with ATI.
- All products are shipped F.O.B. Accessible Technologies, Inc., Lenexa, KS. Standard shipping is via Federal Express Ground unless prior arrangements have been made with ATI.
- A drop shipment fee will apply to all system, kit and head unit orders not shipped to the purchasing dealer. \$35 for systems and kit orders, \$25 for head unit orders.
- Customer is responsible for all duties, customs, fees and shipping charges required to get product to its destination. Export shipping must be arranged in advance with ATI. All payments on export orders must be made in U.S. funds via wire transfer.
- Drop ship orders may be subject to local sales tax requirements.
- Estimated shipping dates can be obtained from ATI sales or customer service (dates are estimated and not guaranteed).
- All packed orders not shipped within 30 days will be returned to inventory and subject to a 5% restocking fee.
- Inspection of product should occur immediately upon arrival. Any claims of shortages or errors originating at ATI must be made within 5 business days from the date of receipt. Damage to product or packaging must be claimed in accordance with the carrier's policies.
- CARB EO's are applicable at time of purchase and are not retroactive. Only systems with an EO# meet emission requirements for all 50 states and are legal for street use on OEM vehicles only (stock engine, stock exhaust, etc).
- F-Series superchargers may require bellmouth or custom air inlet.
- Model years listed in App guide may not be available at time of print. Call for more details.
- All i-1 systems and all special order systems/kits require non-refundable deposit. See footnotes.

## WARRANTY INFORMATION

- 12-month warranty on new, serpentine head unit purchases. Warranty does not cover owner misuse or neglect.
- 36-month head unit only warranty option is available on new, complete systems with P-series & D-1SC head units.
- Limited warranty on cog drive, gear drive or race head unit purchases. Limited means free of manufacturing defects upon receipt.
- 90-day limited warranty on serpentine head unit upgrades.
- 30-day limited warranty on serpentine head unit rebuilds/repairs.
- Exceeding the published supercharger RPM, failure to follow service procedures, or using improper supercharger orientation will void the warranty. The ProCharger warranty applies to original purchaser only and is non-transferrable.
- Failure to use ProCharger specified oil in head units and drives will void ProCharger manufacturer warranty.
- 90-day limited warranty on components purchased separately (excludes electrical and fuel components).
- 30-day limited warranty on electrical components and fuel components.
- 3-year limited warranty on new air-to-air intercoolers.
- 1-year limited warranty on new air-to-water intercoolers.
- Wastegates, methanol injection kits, aftermarket intakes, etc may cause damage to supercharger, intercooler, or intake that will not be covered under warranty.

## RETURNS

- Returns of new, unused product must be pre-approved by ATI/ProCharger. A 20% restocking fee will apply to part orders and head units, and a 12.5% restocking fee will apply to supercharger systems/kits.
- Supercharger systems/kits returned with the factory seal intact are subject to a restocking fee of 10%. No C.O.D or Freight Collect shipments will be accepted by ATI. Used, damaged, special order or discontinued items may not be returned.
- An RMA (Returned Merchandise Authorization) number must be assigned by ATI for all returns and must be displayed in clear view on the outside of the package and be contained in all correspondence.
- No returns are accepted after 90 days. Returns for electrical and fuel components are limited to 30 days.

**2018-23 MUSTANG GT AND CALIFORNIA SPECIAL (5.0 4V) SYSTEMS AND KITS**

Year	Part Number	Description	Boost Options	HP Gain	Intercooler	Price/MAP
2018-23	1FW611-SCI	High Output Intercooled System with Factory Airbox and P-1SC-1	6.5 psi	55-60%+	750+ hp	\$7,999
2018-23	1FW601-SCI	High Output Intercooled Tuner Kit with Factory Airbox and P-1SC-1	specify	specify	750+ hp	\$7,299
2018-23	1FW614-SCI	High Output Intercooled System with P-1SC-1	6.5 psi	55-60%+	750+ hp	\$7,999
2018-23	1FW604-SCI	High Output Intercooled Tuner Kit with P-1SC-1	specify	specify	750+ hp	\$7,249
2018-23	1FW613-SCI	Stage II Intercooled System with Factory Airbox and P-1SC-1	8.5 psi	65-70%+	1200+ hp	\$9,099
2018-23	1FW603-SCI	Stage II Intercooled Tuner Kit with Factory Airbox and P-1SC-1	specify	specify	1200+ hp	\$7,849
2018-23	1FW612-SCI	Stage II Intercooled System with P-1SC-1	8.5 psi	65-70%+	1200+ hp	\$9,099
2018-23	1FW602-SCI	Stage II Intercooled Tuner Kit with P-1SC-1	specify	specify	1200+ hp	\$8,199

**2021-23 MUSTANG MACH 1 AND 2018-20 BULLITT (5.0 4V) SYSTEMS AND KITS**

Year	Part Number	Description	Boost Options	HP Gain	Intercooler	Price/MAP
2018-23	1FW611-SCI	High Output Intercooled System with Factory Airbox and P-1SC-1	6.5 psi	50-55%+	750+ hp	\$7,999
2018-23	1FW601-SCI	High Output Intercooled Tuner Kit with Factory Airbox and P-1SC-1	specify	specify	750+ hp	\$7,299
2018-23	1FW614-SCI	High Output Intercooled System with P-1SC-1	6.5 psi	50-60%+	750+ hp	\$7,999
2018-23	1FW604-SCI	High Output Intercooled Tuner Kit with P-1SC-1	specify	specify	750+ hp	\$7,249
2018-23	1FW613-SCI	Stage II Intercooled System with Factory Airbox and P-1SC-1	8.5 psi	55-60%+	1200+ hp	\$9,099
2018-23	1FW603-SCI	Stage II Intercooled Tuner Kit with Factory Airbox and P-1SC-1	specify	specify	1200+ hp	\$7,849
2018-23	1FW612-SCI	Stage II Intercooled System with P-1SC-1	8.5 psi	55-60%+	1200+ hp	\$9,099
2018-23	1FW602-SCI	Stage II Intercooled Tuner Kit with P-1SC-1	specify	specify	1200+ hp	\$8,199

**2015-20 GT350 AND GT350R (5.2 4V) SYSTEMS AND KITS**

Year	Part Number	Description	Boost Options	HP Gain	Intercooler	Price/MAP
2015-20	1FW312-SCI	High Output Intercooled System with P-1SC-1	6 psi	175+ hp	1100+ hp	\$8,599
2015-20	1FW302-SCI	High Output Intercooled Tuner Kit with P-1SC-1	specify	specify	1100+ hp	\$7,749
2015-20	1FW314-SCI	Stage II Intercooled System with P-1SC-1	9 psi	350 + hp	1100+ hp	\$9,949
2015-20	1FW304-SCI	Stage II Intercooled Tuner Kit with P-1SC-1	specify	specify	1100+ hp	\$8,449

<b>2015-23 MUSTANG GT MACH 1 BULLITT GT350 OPTIONS</b>	add "-B" or "-P" to part #	Black or Polished finish for ProCharger (P-series or D-series)	satin standard	-	-	+\$325
	add "-B" or "-P" to part #	Black or Polished finish for ProCharger (F-series, 9" or 9.75" housing)	satin standard	-	-	+\$350
	add "-BB" or "-PB" to part #	Black or Polished finish for supercharger bracket	satin standard	-	-	+\$275
	add "-BI" to part #	Black finish for Intercooler (1200+ hp Intercooler Only)	satin standard	-	-	+\$175
	add "-H" to part #	Helical gearset for noise reduction (P-1SC-1, P-1X, D-1SC, D-1X)	same	same	-	+\$110
	add "-D1SC" to part #	With D-1SC ProCharger (replacing P-1SC-1)	tuner kit only	specify	-	+\$275
	add "-BV" to part #	Bullet Bypass Valve Upgrade	black only	-	-	+\$125
	add "-Race" to part #	1200+ hp Intercooler Upgrade (replacing 750+ hp intercooler) - Tuner kits only	HO GT only	1200+ hp	-	+\$435
	add "-P1X" to part #	With P-1X ProCharger (replacing P-1SC-1, Systems and Tuner Kits)	same	add'l 15+ hp	-	+\$250
	add "-D1X" to part #	With D-1X ProCharger (replacing P-1SC-1, Tuner Kits only)	tuner kit only	specify	-	+\$475
	add "-D" or "-1" or "-A"	With F-1D, F-1, F-1A ProCharger (replacing P-1SC-1)	tuner kit only	specify	-	+\$875
	add "-94"	With F-1A-94 (replacing P-1SC-1, Stage II Tuner kits only)	tuner kit only	-	-	+\$1,225
	add "-RVR" or "-RVB"	Race Bypass Valve Upgrade (specify open or closed valve; red or black) Stage II only	from ProFlow	specify	-	+\$295
	add "-INJ" to part #	95 lb/hr Fuel Injectors (Tuner kits only)	tuner kit only	specify	-	+\$750
	add "-10R" to part #	10 rib drive system upgrade (2018-23 GT Stage II Tuner Kits only)	from 8 rib	-	-	+\$360
	add "-CP" to part #	8" Crank Pulley Upgrade	-	-	-	+\$750
	add "-CS" to part #	Coyote Crank Support	satin standard	-	-	+\$675
add "-BC" or "-PC" to part #	Black or Polished finish for Crank Support	satin standard	-	-	+\$275	
<b>GT350 ONLY</b>	add "-CP" to part #	7.00" Crank Pulley Upgrade	6.25" standard	-	-	+\$120

**CALL FOR INFORMATION ABOUT 2024 MUSTANG GT & DARK HORSE**



# SPECIFICATIONS (2015-23 MUSTANG)

## 2018-23 MUSTANG GT AND CALIFORNIA SPECIAL (5.0 4V) SPECIFICATIONS

Year	Part Number	OEM hp Rating	HP Gain	Tube Diam	Intercooler Mount	Drive System	Bypass System	Fuel System Upgrade	Fuel Inj. Supplied	Computer/Ignition Modifications	Supercharger Warranty (in months)	CARB E.O.	Foot Notes
2018-23	1FW611-SCI	460	55-60%+	3-3.5"	V	stk 6 rib	ProFlow	not required	not required	programmer supplied	12, 36 opt. (\$99)	D-365-31 (18-22)	A1, A3, A5, A8, A15
2018-23	1FW601-SCI	460	specify	3-3.5"	V	stk 6 rib	ProFlow	not supplied	No	not supplied	12	-	A1, A3, A5, A8, A15
2018-23	1FW614-SCI	460	55-60%+	3-3.5"	V	stk 6 rib	ProFlow	not required	not required	programmer supplied	12, 36 opt. (\$99)	-	A1, A2, A3, A5, A8, A11, A15
2018-23	1FW604-SCI	460	specify	3-3.5"	V	stk 6 rib	ProFlow	not supplied	No	not supplied	12	-	A1, A3, A5, A8, A11, A15
2018-23	1FW613-SCI	460	65-70%+	3-3.5"	V	stk 6 rib	ProFlow	pump voltage booster	not required	programmer supplied	12, 36 opt. (\$99)	D-365-31 (18-22)	A1, A3, A5, A8, A15
2018-23	1FW603-SCI	460	specify	3-3.5"	V	stk 6 rib	ProFlow	not supplied	No	not supplied	12	-	A1, A3, A5, A8, A15
2018-23	1FW612-SCI	460	65-70%+	3-3.5"	V	add'l 8 rib	ProFlow	not required	not required	programmer supplied	12, 36 opt. (\$99)	-	A1, A2, A3, A5, A8, A10, A15
2018-23	1FW602-SCI	460	specify	3-3.5"	V	add'l 8 rib	ProFlow	not supplied	No	not supplied	12	-	A1, A3, A5, A8, A10, A12, A15

## 2021-23 MUSTANG MACH 1 AND 2018-20 BULLITT (5.0 4V) SPECIFICATIONS

Year	Part Number	OEM hp Rating	HP Gain	Tube Diam	Intercooler Mount	Drive System	Bypass System	Fuel System Upgrade	Fuel Inj. Supplied	Computer/Ignition Modifications	Supercharger Warranty (in months)	CARB E.O.	Foot Notes
2018-23	1FW611-SCI	480	50-55%+	3-3.5"	V	stk 6 rib	ProFlow	not required	not required	programmer supplied	12, 36 opt. (\$99)	D-365-31 (18-22)	A1, A3, A5, A8, A15
2018-23	1FW601-SCI	480	specify	3-3.5"	V	stk 6 rib	ProFlow	not supplied	No	not supplied	12	-	A1, A3, A5, A8, A15
2018-23	1FW614-SCI	480	50-60%+	3-3.5"	V	stk 6 rib	ProFlow	not required	not required	programmer supplied	12, 36 opt. (\$99)	-	A1, A2, A3, A5, A8, A11, A15
2018-23	1FW604-SCI	480	specify	3-3.5"	V	stk 6 rib	ProFlow	not supplied	No	not supplied	12	-	A1, A3, A5, A8, A11, A15
2018-23	1FW613-SCI	480	55-60%+	3-3.5"	V	stk 6 rib	ProFlow	pump voltage booster	not required	programmer supplied	12, 36 opt. (\$99)	D-365-31 (18-22)	A1, A3, A5, A8, A15
2018-23	1FW603-SCI	480	specify	3-3.5"	V	stk 6 rib	ProFlow	not supplied	No	not supplied	12	-	A1, A3, A5, A8, A15
2018-23	1FW612-SCI	480	55-60%+	3-3.5"	V	add'l 8 rib	ProFlow	not required	not required	programmer supplied	12, 36 opt. (\$99)	-	A1, A2, A3, A5, A8, A10, A15
2018-23	1FW602-SCI	480	specify	3-3.5"	V	add'l 8 rib	ProFlow	not supplied	No	not supplied	12	-	A1, A3, A5, A8, A10, A12, A15

## 2015-20 GT350 AND GT350R (5.2 4V) SPECIFICATIONS

Year	Part Number	OEM hp Rating	HP Gain	Tube Diam	Intercooler Mount	Drive System	Bypass System	Fuel System Upgrade	Fuel Inj. Supplied	Computer/Ignition Modifications	Supercharger Warranty (in months)	CARB E.O.	Foot Notes
2015-20	1FW312-SCI	526	175+hp	3"	V	stk 6 rib	ProFlow	not required	95 lb/hr	programmer supplied	12, 36 opt. (\$99)	-	A1, A2, A3, A4, A5, A8, A11
2015-20	1FW302-SCI	526	specify	3"	V	stk 6 rib	ProFlow	not supplied	No	not supplied	12	-	A1, A3, A4, A5, A8, A11
2015-20	1FW314-SCI	526	350+hp	3"	V	add'l 8 rib	ProFlow	not supplied	95 lb/hr	programmer supplied	12, 36 opt. (\$99)	-	A1, A2, A3, A8, A9, A10
2015-20	1FW304-SCI	526	specify	3"	V	add'l 8 rib	ProFlow	not supplied	No	not supplied	12	-	A1, A3, A8, A9, A10, A12

### FORD AUTOMOTIVE FOOTNOTES (specific to above applications):

- |  |   |
|--|---|
| A1) Model year must be specified   | A8) Specify manual or automatic transmission                            |
| A2) Due to variability among OEM computers, the prevalence of custom modifications, and age/miles/condition of vehicles, dyno tuning may be required | A9) Aftermarket balancer is included in Stage II GT350 Systems and Kits |
| A3) System ships in extra large box  | A10) Factory sway bar only  |
| A4) California Special models may require trimming   | A11) Minor timing cover modifications may be required                   |
| A5) Specify factory or aftermarket balancer (ATI P/N 918047)   | A12) Crank Support requires removal of factory sway bar                 |
|  | A15) Mach 1 hood liner may require trimming                             |



**2015-17 MUSTANG GT (5.0 4V) SYSTEMS AND KITS**

Year	Part Number	Description	Boost Options	HP Gain	Intercooler	Price/MAP
2015-17	1FW411-SCI	High Output Intercooled System with Factory Airbox and P-1SC-1	8 psi	55-60%+	750+ hp	\$7,999
2015-17	1FW401-SCI	High Output Intercooled Tuner Kit with Factory Airbox and P-1SC-1	specify	specify	750+ hp	\$7,149
2015-17	1FW214-SCI	High Output Intercooled System with P-1SC-1	8 psi	55-60%+	750+ hp	\$7,999
2015-17	1FW204-SCI	High Output Intercooled Tuner Kit with P-1SC-1	specify	specify	750+ hp	\$7,149
2015-17	1FW412-SCI	Stage II Intercooled System with Factory Airbox and P-1SC-1	9 psi	60-65%+	1200+ hp	\$8,899
2015-17	1FW402-SCI	Stage II Intercooled Tuner Kit with Factory Airbox and P-1SC-1	specify	specify	1200+ hp	\$7,649
2015-17	1FW212-SCI	Stage II Intercooled System with P-1SC-1	10 psi	65-70%+	1200+ hp	\$9,249
2015-17	1FW202-SCI	Stage II Intercooled Tuner Kit with P-1SC-1	specify	specify	1200+ hp	\$7,749

**2015-17 MUSTANG V6 (3.7 4V) SYSTEMS AND KITS**

Year	Part Number	Description	Boost Options	HP Gain	Intercooler	Price/MAP
2015-17	1FT412-SCI	Intercooled Supercharger System with P-1SC-1	8 psi	50-55%	750+ hp	\$7,699
2015-17	1FT402-SCI	Intercooled Supercharger Tuner Kit with P-1SC-1	specify	specify	750+ hp	\$6,999

<b>2015-17 MUSTANG GT AND V6 OPTIONS</b>	add "-B" or "-P" to part #	Black or Polished finish for ProCharger (P-series or D-series)	satin standard	-	-	+\$325
	add "-B" or "-P" to part #	Black or Polished finish for ProCharger (F-series, 9" or 9.75" housing)	satin standard	-	-	+\$350
	add "-BB" or "-PB" to part #	Black or Polished finish for supercharger bracket	satin standard	-	-	+\$275
	add "-BI" to part #	Black finish for Intercooler (1200+ hp Intercooler Only)	satin standard	-	-	+\$175
	add "-H" to part #	Helical gearset for noise reduction (P-1SC-1, P-1X, D-1SC, D-1X)	same	same	-	+\$110
	add "-D1SC" to part #	With D-1SC ProCharger (replacing P-1SC-1)	tuner kit only	specify	-	+\$275
	add "-BV" to part #	Bullet Bypass Valve Upgrade	black only	-	-	+\$125
	add "-Race" to part #	1200+ hp Intercooler Upgrade (replacing 750+ hp intercooler) - Tuner kits only	HO GT only	1200+ hp	-	+\$435
<b>2015-17 MUSTANG GT ONLY OPTIONS</b>	add "-P1X" to part #	With P-1X ProCharger (replacing P-1SC-1, Systems and Tuner Kits)	same	add'l 15+ hp	-	+\$250
	add "-D1X" to part #	With D-1X ProCharger (replacing P-1SC-1, Tuner Kits only)	tuner kit only	specify	-	+\$475
	add "-D" or "-1" or "-A"	With F-1D, F-1, F-1A ProCharger (replacing P-1SC-1)	tuner kit only	specify	-	+\$875
	add "-94" or "-C" or "-R"	With F-1A-94, F-1C or F-1R (replacing P-1SC-1, Stage II Tuner kits only)	tuner kit only	-	-	+\$1,225
	add "-RVR" or "RVB"	Race Bypass Valve Upgrade (specify open or closed valve; red or black) Stage II only	from ProFlow	specify	-	+\$295
	add "-INJ" to part #	95 lb/hr Fuel Injectors (Tuner kits only)	tuner kit only	specify	-	+\$750
	add "-10R" to part #	10 rib drive system upgrade (2015-17 GT Stage II Tuner Kits only)	from 8 rib	-	-	+\$360
	add "-CS" to part #	Coyote Crank Support	satin standard			+\$675
	add "-BC" or "-PC" to part #	Black or Polished finish for Crank Support	satin standard			+\$275
<b>V6 ONLY</b>	add "-AIR" to part #	Stage II air inlet upgrade package (replacing HO standard inlet)	same	specify	-	+\$45

**FOR COYOTE & GODZILLA ENGINE SWAP KITS, SEE PAGE 24**



# SPECIFICATIONS (2015-17 MUSTANG)

## 2015-17 MUSTANG GT (5.0 4V) SPECIFICATIONS

Year	Part Number	OEM hp Rating	HP Gain	Tube Diam	Intercooler Mount	Drive System	Bypass System	Fuel System Upgrade	Fuel Inj. Supplied	Computer/Ignition Modifications	Supercharger Warranty (in months)	CARB E.O.	Foot Notes
2015-17	1FW411-SCI	435	55-60%+	3"	V	stk 6 rib	ProFlow	not required	52 lb/hr	programmer supplied	12, 36 opt. (\$99)	D-365-16	AA1, AA3, AA4, AA5, AA8
2015-17	1FW401-SCI	435	specify	3"	V	stk 6 rib	ProFlow	not supplied	No	not supplied	12	-	AA1, AA3, AA4, AA5, AA8
2015-17	1FW214-SCI	435	55-60%+	3"	V	stk 6 rib	ProFlow	not required	52 lb/hr	programmer supplied	12, 36 opt. (\$99)	-	AA1, AA2, AA3, AA4, AA5, AA8, A11
2015-17	1FW204-SCI	435	specify	3"	V	stk 6 rib	ProFlow	not supplied	No	not supplied	12	-	AA1, AA3, AA4, AA5, AA8, A11
2015-17	1FW412-SCI	435	60-65%+	3"	V	stk 6 rib	ProFlow	pump voltage booster	52 lb/hr	programmer supplied	12, 36 opt. (\$99)	D-365-16	AA1, AA3, AA4, AA5, AA8
2015-17	1FW202-SCI	435	specify	3"	V	stk 6 rib	ProFlow	not supplied	No	not supplied	12	-	AA1, AA3, AA4, AA5, AA6, AA8
2015-17	1FW212-SCI	435	65-70%+	3"	V	add'l 8 rib	ProFlow	pump voltage booster	95 lb/hr	programmer supplied	12, 36 opt. (\$99)	-	AA: 1,2,3,4,5,8,10,12,13
2015-17	1FW202-SCI	435	specify	3"	V	add'l 8 rib	ProFlow	not supplied	No	not supplied	12	-	AA: 1,2,3,4,5,8,10,12,13

## 2015-17 MUSTANG V6 (3.7V) SPECIFICATIONS

Year	Part Number	OEM hp Rating	HP Gain	Tube Diam	Intercooler Mount	Drive System	Bypass System	Fuel System Upgrade	Fuel Inj. Supplied	Computer/Ignition Modifications	Supercharger Warranty (in months)	CARB E.O.	Foot Notes
2015-17	1FT412-SCI	300	50-55%	3"	V	add'l 6 rib	ProFlow	not required	50 lb/hr	programmer supplied	12, 36 opt. (\$99)	-	AA1, AA2, AA3, AA7, AA8
2015-17	1FT402-SCI	300	specify	3"	V	add'l 6 rib	ProFlow	not supplied	No	not supplied	12	-	AA1, AA3, AA7, AA8

### FORD AUTOMOTIVE FOOTNOTES (specific to above applications):

- AA1) Model year must be specified
- AA2) Due to variability among OEM computers, the prevalence of custom modifications, and age/miles/condition of vehicles, dyno tuning may be required; Stock vehicles with cat-back exhaust systems may also require custom tuning
- AA3) System ships in extra large box
- AA4) California Special models may require trimming
- AA5) Specify factory or aftermarket balancer

- AA7) Upgraded driveshaft recommended
- AA8) Specify manual or automatic transmission
- AA10) Factory sway bar only
- AA11) Minor timing cover modifications may be required.
- AA12) Crank Support requires removal of factory sway bar
- AA13) ATI Balancer P/N 918047 optional



CONTACT US AT (913) 338-2886 OR LEARN MORE [PROCHARGER.COM](http://PROCHARGER.COM)

## 2011-14 MUSTANG GT (5.0 4V) SYSTEMS AND KITS

Year	Part Number	Description	Boost Options	HP Gain	Intercooler	Price/MAP
2011-14	1FR211-SCI	High Output Intercooled System with Factory Airbox and P-1SC-1 (shared drive)	Call	Call	750+ hp	Call
2011-14	1FR201-SCI	High Output Intercooled Tuner Kit with Factory Airbox and P-1SC-1 (shared drive)	specify	specify	750+ hp	\$6,899
2011-12	1FR214-SCI	High Output Intercooled System with P-1SC-1	7.5 psi	50%+	3 core	\$7,899
2011-12	1FR204-SCI	High Output Intercooled Tuner Kit with P-1SC-1	specify	specify	3 core	\$7,049
2011-14	1FR212-SCI	Stage II Intercooled System with P-1SC-1	8 psi	55%+	Stage II	\$8,599
2011-14	1FR202-SCI	Stage II Intercooled Tuner Kit with P-1SC-1	specify	specify	Stage II	\$7,749
2011-14	1FR200-F1	Intercooled Cog Race Kit with F-1D, F-1 or F-1A	specify	specify	Race	\$9,099
2011-14	1FR200-SCI-94	Intercooled Cog Race Kit with F-1A-94, F-1C or F-1R	specify	specify	Race	\$9,399

<b>2011-14 MUSTANG GT OPTIONS</b>	add "-B" or "-P" to part #	Black or Polished finish for ProCharger (P-series or D-series )	satin standard	-	-	+\$325
	add "-B" or "-P" to part #	Black or Polished finish for ProCharger (F-series, 9" or 9.75" housing)	satin standard	-	-	+\$350
	add "-BB" or "-PB" to part #	Black or Polished finish for supercharger bracket	satin standard	-	-	+\$275
	add "-H" to part #	Helical gerset for noise reduction (P-1SC-1, P-1X, D-1SC, D-1X)	same	same	-	+\$110
	add "P1X" to part #	With P-1X ProCharger (replacing P-1SC-1, Systems and Tuner Kits)	same	add'l 10-15+ hp	-	+\$250
	add "-D1SC" to part #	With D-1SC ProCharger (replacing P-1SC-1)	tuner kit only	specify	-	+\$275
	add "-D1X" to part #	With D-1X ProCharger (replacing P-1SC-1, Tuner Kits only)	tuner kit only	specify	-	+\$475
	add "-D" or "-1" or "-A"	With F-1D, F-1, F-1A ProCharger (replacing P-1SC-1)	tuner kit only	specify	-	+\$875
	add "-94" or "-C" or "-R"	With F-1A-94, F-1C or F-1R (replacing P-1SC-1, Stage II Tuner Kits only)	tuner kit only	-	-	+\$1,225
	add "-RVR" or "-RVB"	Race Bypass Valve Upgrade (specify open or closed valve; red or black)	from ProFlow	specify	-	+\$295
	add "-10R" to part #	10 rib drive system upgrade (2011-14 Stage II Tuner Kits only)	from 8 rib	-	-	+\$360
	add "-AIR" to part #	Stage II air inlet upgrade package (replacing HO standard inlet)	same	specify	-	+\$45
	add "-CS" to part #	Coyote Crank Support	satin standard			+\$675
add "-BC" or "-PC" to part #	Black or Polished finish for Crank Support	satin standard			+\$275	
add "-Race" to part #	Air-to-Air Race intercooler upgrade	from Stage II	1000 hp max	3" Tubing	+\$435	

## 2011-14 MUSTANG GT (5.0 4V) i-1 PROGRAMMABLE RATIO SYSTEMS

Year	Part Number	Description	Boost Options	HP Gain	Intercooler	Price/MAP
2011-14	1FR215-SCI	Stage II Intercooled System with i-1	7.5 psi	55%+	Stage II	\$10,399

<b>i-1 OPTIONS</b>	add "-T" to part #	Touchscreen (at time of system purchase)	-	-	-	+\$395
	add "-B" to part #	Black finish (supercharger and bracket)	satin standard	-	-	+\$795
	add "-P" to part #	Polished finish (supercharger and bracket)	satin standard	-	-	+\$595
	add "-R" to part #	Air-to-air race intercooler upgrade	satin standard	-	-	+\$435

## 2011-14 MUSTANG V6 (3.7 4V) SYSTEMS AND KITS

Year	Part Number	Description	Boost Options	HP Gain	Intercooler	Price/MAP
2011-14	1FT212-SCI	Intercooled Supercharger System with P-1SC-1	8 psi	50-60%	3 core	\$7,699
2011-14	1FT202-SCI	Intercooled Supercharger Tuner Kit with P-1SC-1	specify	specify	3 core	\$6,899

<b>2011-14 MUSTANG V6 (3.7) OPTIONS</b>	add "-B" or "-P" to part #	Black or Polished finish for ProCharger (P-series or D-series )	satin standard	-	-	+\$325
	add "-BB" or "-PB" to part #	Black or Polished finish for supercharger bracket	satin standard	-	-	+\$275
	add "-H" to part #	Helical gerset for noise reduction (P-1SC-1, D-1SC)	same	same	-	+\$110
	add "-D1SC" to part #	With D-1SC ProCharger (replacing P-1SC-1)	tuner kit only	-	-	+\$275
	add "-AIR" to part #	With cold air inlet upgrade package (replacing standard inlet)	same	specify	-	+\$45

**FOR COYOTE & GODZILLA ENGINE SWAP KITS, SEE PAGE 24**



# SPECIFICATIONS (2011-14 MUSTANG)

## 2011-14 MUSTANG GT (5.0 4V) SPECIFICATIONS

Year	Part Number	OEM hp Rating	HP Gain	Tube Diam	IC Mount	Drive System	Bypass System	Fuel System Upgrade	Fuel Inj. Supplied	Computer/Ignition Modifications	Supercharger Warranty (in months)	CARB E.O.	Foot Notes
2011-14	1FR211-SCI	412	Call	3"	V	stk 6 rib	ProFlow	not required	52 lb/hr	programmer supplied	12, 36 opt. (\$99)	Call	B1, B2, B4, B5, B6, B10, B12
2011-14	1FR201-SCI	412	specify	3"	V	stk 6 rib	ProFlow	not supplied	No	not supplied	12	-	B1, B4, B5, B6, B10
2011-12	1FR214-SCI	412	50%+	3"	V	add'l 8 rib	ProFlow	not required	52 lb/hr	programmer supplied	12, 36 opt. (\$99)	-	B1, B2, B4, B5, B6, B8, B10, B11, B12
2011-12	1FR204-SCI	412	specify	3"	V	add'l 8 rib	ProFlow	not supplied	No	not supplied	12	-	B1, B4, B5, B6, B8, B9, B10, B11
2011-14	1FR212-SCI	412	55%+	3"	V	add'l 8 rib	ProFlow	not required	52 lb/hr	programmer supplied	12, 36 opt. (\$99)	-	B1, B2, B4, B5, B7, B8, B10, B11, B12
2011-14	1FR202-SCI	412	specify	3"	V	add'l 8 rib	ProFlow	not supplied	No	not supplied	12	-	B1, B4, B5, B7, B8, B9, B10, B11
2011-14	1FR200-F1	-	specify	3"	V	cog	Race	not supplied	No	not supplied	Limited	-	B1, B3, B4, B5, B8, B9, B10
2011-14	1FR200-SCI-94	-	specify	3"	V	cog	Race	not supplied	No	not supplied	Limited	-	B1, B3, B4, B5, B8, B9, B10

## 2011-14 MUSTANG GT (5.0 4V) i-1 PROGRAMMABLE RATIO SPECIFICATIONS

Year	Part Number	OEM hp Rating	HP Gain	Tube Diam	IC Mount	Drive System	Bypass System	Fuel System Upgrade	Fuel Inj. Supplied	Computer/Ignition Modifications	Supercharger Warranty (in months)	CARB E.O.	Foot Notes
2011-14	1FR215-SCI	412	55%+	3"	V	add'l 8 rib	ProFlow	not required	52 lb/hr	programmer supplied	12, 36 opt. (\$149)	-	B1, B2, B4, B8, B10, B12, B14, B16

## 2011-14 MUSTANG V6 (3.7 4V) SPECIFICATIONS

Year	Part Number	OEM hp Rating	HP Gain	Tube Diam	IC Mount	Drive System	Bypass System	Fuel System Upgrade	Fuel Inj. Supplied	Computer/Ignition Modifications	Supercharger Warranty (in months)	CARB E.O.	Foot Notes
2011-14	1FT212-SCI	305	50-60%	3"	V	add'l 6 rib	ProFlow	not required	50 lb/hr	programmer supplied	12, 36 opt. (\$99)	-	B1, B2, B4, B12, B13
2011-14	1FT202-SCI	305	specify	3"	V	add'l 6 rib	ProFlow	not supplied	No	not supplied	12	-	B1, B4, B13

## FORD AUTOMOTIVE FOOTNOTES (specific to above applications):

- B1) Model year must be specified
- B2) Due to variability among OEM computers, the prevalence of custom modifications, and age/miles/condition of vehicles, dyno tuning may be required; Stock vehicles with cat-back exhaust systems may also require custom tuning
- B3) Modified engines only
- B4) System ships in extra large box
- B5) California Special models may require trimming
- B6) Fog lights may need to be removed in 2013-14 Mustang GT vehicles with HO Systems and Kits
- B7) 2011-12 Stage II Systems require trimming of plastic bumper cover (behind bumper, not visible)
- B8) Specify factory or aftermarket balancer
- B9) Specify ATI Balancer #918047 or Innovators West #817 required for 10-rib upgrade and Cog Kits (not included - specify hardened hub)
- B10) Specify if vehicle has optional Ford track-pack package
- B11) Stage II air inlet does not fit in 2011-14 Mustang GT vehicles equipped with upper strut bar
- B12) ECM code required
- B13) Upgraded driveshaft recommended
- B14) Two-part shipment, additional shipping charges may apply
- B16) Special order kit: order form and non-refundable deposit required at time of order—may require additional lead time for processing



## 2012-13 BOSS 302 MUSTANG SYSTEMS AND KITS

Year	Part Number	Description	Boost Options	HP Gain	Intercooler	Price/MAP
2012-13	1FR311-SCI	High Output Intercooled System with Factory Airbox and P-1SC-1 (shared drive)	Call	Call	750+ hp	Call
2012-13	1FR301-SCI	High Output Intercooled Tuner Kit with Factory Airbox and P-1SC-1 (shared drive)	specify	specify	750+ hp	Call
2012-13	1FR312-SCI	Stage II Intercooled System with P-1SC-1	8.5 psi	50%+	Stage II	\$8,699
2012-13	1FR302-SCI	Stage II Intercooled Tuner Kit with P-1SC-1	specify	specify	Stage II	\$7,849
2012-13	1FR300-F1	Intercooled Cog Race Kit with F-1D, F-1 or F-1A	specify	specify	Race	\$9,149
2012-13	1FR300-SCI-94	Intercooled Cog Race Kit with F-1A-94, F-1C or F-1R	specify	specify	Race	\$9,349

<b>2012-13 BOSS 302 OPTIONS</b>	add "-B" or "-P" to part #	Black or Polished finish for ProCharger (P-series or D-series)	satin standard	-	-	+\$325
	add "-B" or "-P" to part #	Black or Polished finish for ProCharger (F-series, 9" or 9.75" housing)	satin standard	-	-	+\$350
	add "-BB" or "-PB" to part #	Black or Polished finish for supercharger bracket	satin standard	-	-	+\$275
	add "-H" to part #	Helical gearset for noise reduction (P-1SC-1, P-1X, D-1SC, D-1X)	same	same	-	+\$110
	add "-P1X" to part #	With P-1X ProCharger (replacing P-1SC-1, Systems and Tuner Kits)	same	add'l 10-15+ hp	-	+\$250
	add "-D1SC" to part #	With D-1SC ProCharger (replacing P-1SC-1)	tuner kit only	specify	-	+\$275
	add "-D1X" to part #	With D-1X ProCharger (replacing P-1SC-1, Tuner Kits only)	tuner kit only	specify	-	+\$475
	add "-D" or "-1" or "-A"	With F-1D, F-1, F-1A ProCharger (replacing P-1SC-1)	tuner kit only	specify	-	+\$875
	add "-94" or "-C" or "-R"	With F-1A-94, F-1C or F-1R ProCharger (replacing P-1SC-1)	tuner kit only	-	-	+\$1,225
	add "-10R" to part #	10 rib drive system upgrade (Stage II tuner kits only)	from 8 rib	-	-	+\$360
	add "-RVR" or "RVB"	Race Bypass Valve Upgrade (specify open or closed valve; red or black)	from ProFlow	specify	-	+\$295
	add "-CS" to part #	Coyote Crank Support	satin standard	-	-	+\$675
add "-BC" or "-PC" to part #	Black or Polished finish for Crank Support	satin standard	-	-	+\$275	
add "-Race" to part #	Air-to-Air Race intercooler upgrade (Stage II only)	from Stage II	1000 hp max	3" Tubing	+\$435	

## 2012-13 BOSS 302 MUSTANG i-1 PROGRAMMABLE RATIO SYSTEMS

Year	Part Number	Description	Boost Options	HP Gain	Intercooler	Price/MAP
2012-13	1FR315-SCI	Stage II Intercooled System with i-1	8.5 psi	55%+	Stage II	\$10,499

<b>i-1 OPTIONS</b>	add "-T" to part #	Touchscreen (at time of system purchase)	-	-	-	+\$395
	add "-B" to part #	Black finish (supercharger and bracket)	satin standard	-	-	+\$795
	add "-P" to part #	Polished finish (supercharger and bracket)	satin standard	-	-	+\$595
	add "-R" to part #	Air-to-Air Race Intercooler upgrade	-	-	-	+\$435

**FOR COYOTE & GODZILLA ENGINE SWAP KITS, SEE PAGE 24**



# SPECIFICATIONS (2012-13 BOSS 302 MUSTANG)

## 2012-13 BOSS 302 MUSTANG SPECIFICATIONS

Year	Part Number	OEM hp Rating	HP Gain	Tube Diam	Intercooler Mount	Drive System	Bypass System	Fuel System Upgrade	Fuel Inj. Supplied	Computer/Ignition Modifications	Supercharger Warranty (in months)	CARB E.O.	Foot Notes
2012-13	1FR311-SCI	444	Call	3"	V	stk 6 rib	ProFlow	not required	52 lb/hr	programmer supplied	12, 36 opt. (\$99)	Call	C1, C2, C4, C8, C9
2012-13	1FR301-SCI	444	specify	3"	V	stk 6 rib	ProFlow	not supplied	No	not supplied	12	-	C1, C4
2012-13	1FR312-SCI	444	50%+	3"	V	add'l 8 rib	ProFlow	pump voltage booster	52 lb/hr	programmer supplied	12, 36 opt. (\$99)	-	C1, C2, C4, C5, C6, C7, C8, C9
2012-13	1FR302-SCI	444	specify	3"	V	add'l 8 rib	ProFlow	not supplied	No	not supplied	12	-	C1, C4, C5, C6, C7
2012-13	1FR300-F1	-	specify	3"	V	cog	Race	not supplied	No	not supplied	Limited	-	C1, C3, C4, C7
2012-13	1FR300-SCI-94	-	specify	3"	V	cog	Race	not supplied	No	not supplied	Limited	-	C1, C3, C4, C7

## 2012-13 BOSS 302 MUSTANG i-1 PROGRAMMABLE RATIO SPECIFICATIONS

Year	Part Number	OEM hp Rating	HP Gain	Tube Diam	Intercooler Mount	Drive System	Bypass System	Fuel System Upgrade	Fuel Inj. Supplied	Computer/Ignition Modifications	Supercharger Warranty (in months)	CARB E.O.	Foot Notes
2012-13	1FR315-SCI	444	55%+	3"	V	add'l 8 rib	ProFlow	pump voltage booster	52 lb/hr	programmer supplied	12, 36 opt. (\$149)	-	C1, C2, C4, C6, C8, C9, C10, C11

## FORD AUTOMOTIVE FOOTNOTES (specific to above applications):

- C1) Model year must be specified
- C2) Due to variability among OEM computers, the prevalence of custom modifications, and age/miles/condition of vehicles, dyno tuning may be required
- C3) Modified engines only
- C4) System ships in extra large box
- C5) 2012 Stage II Systems require trimming of plastic bumper cover (behind bumper, not visible)
- C6) Specify factory or aftermarket balancer
- C7) Mustang ATI Balancer #918047 required for 12-rib upgrade and Cog Kits
- C8) ProCharger tune overrides Ford TrackKey/Boss 302 performance calibrations
- C9) ECM code required
- C10) Two-part shipment, additional shipping charges may apply
- C11) Special order kit: order form and non-refundable deposit required at time of order—may require additional lead time for processing



**2005-10 MUSTANG GT (4.6 3V) SYSTEMS AND KITS**

Year	Part Number	Description	Boost Options	HP Gain	Intercooler	Price/MAP
2005-10	1FP311-SCI	<a href="#">Intercooled Supercharger System with P-1SC-1 (shared drive)</a>	Call	Call	3 core	Call
2005-10	1FP301-SCI	<a href="#">Intercooled Supercharger Tuner Kit with P-1SC-1 (shared drive)</a>	Call	Call	3 core	Call
2005-10	1FP214-SCI	<a href="#">High Output Intercooled System with P-1SC-1</a>	10 psi	70-75%	3 core	\$7,699
2005-10	1FP204-SCI	<a href="#">High Output Intercooled Tuner Kit with P-1SC-1</a>	specify	specify	3 core	\$6,799
2005-09	1FP211-SCI	<a href="#">Stage II Intercooled System with P-1SC-1</a>	10 psi	70-75%	3 core	\$8,199
2005-09	1FP202-SCI	<a href="#">Stage II Intercooled Tuner Kit with P-1SC-1</a>	specify	specify	3 core	\$7,299
2005-09	1FP213-F1	<a href="#">Intercooled Serp Race Kit (12 rib) with F-1A</a>	specify	specify	800+ hp	\$8,699

<b>2005-10 MUSTANG GT (4.6 3V) OPTIONS</b>	add "-B" or "-P" to part #	Black or Polished finish for ProCharger (P-series or D-series )	satin standard	-	-	+\$325
	add "-B" or "-P" to part #	Black or Polished finish for ProCharger (F-series, 9" or 9.75" housing)	satin standard	-	-	+\$350
	add "-PT" to part #	Polished finish for throttle body tube inlet	satin standard	-	-	+\$175
	add "-BB" or "-PB" to part #	Black or Polished finish for supercharger bracket	satin standard	-	-	+\$275
	add "-H" to part #	Helical gearset for noise reduction (P-1SC-1, D-1SC)	same	same	-	+\$110
	add "-D1SC" to part #	With D-1SC ProCharger (replacing P-1SC-1)	tuner kit only	specify	-	+\$275
	add "-D" or "-1" or "-A"	With F-1D, F-1, F-1A ProCharger (replacing P-1SC-1, Stage II only)	tuner kit only	specify	-	+\$875
	add "-94" or "-C" or "-R"	With F-1A-94, F-1C or F-1R (replacing P-1SC-1, Stage II Tuner Kits only)	tuner kit only	-	-	+\$1,225
	add "-94" or "-C" or "-R"	With F-1A-94, F-1C or F-1R (replacing F-1A, Serpentine Race Kits only)	race kit only	-	-	+\$350
add "-RVR" or "RVB"	Race Bypass Valve Upgrade (specify open or closed valve; red or black)	from ProFlow	specify	-	+\$295	
add "-800" to part #	800+ hp intercooler system upgrade (Stage II only)	from 3 core	900 hp max	3" tubing	+\$435	

**2005-10 MUSTANG V6 (4.0) SYSTEMS AND KITS**

Year	Part Number	Description	Boost Options	HP Gain	Intercooler	Price/MAP
2005-10	1FQ212-SCI	<a href="#">Stage II Intercooled System with P-1SC</a>	8 psi	55-60%	2 core	\$6,849
2005-10	1FQ202-SCI	<a href="#">Intercooled Tuner Kit with P-1SC</a>	specify	specify	2 core	\$5,999

<b>2005-10 MUSTANG V6 (4.0) OPTIONS</b>	add "-B" or "-P" to part #	Black or Polished finish for ProCharger (P-series or D-series)	head unit only	-	-	+\$325
	add "-H" to part #	Helical gearset for noise reduction (P-1SC, P-1SC-1, D-1SC)	same	same	-	+\$110
	add "-C" to part #	With P-1SC-1 ProCharger (replacing P-1SC, Stage II and Tuner Kit only)	same as P-1SC	-	-	+\$220
	add "-D1SC" to part #	With D-1SC ProCharger (replacing P-1SC)	tuner kit only	-	-	+\$495
	add "-3C" to part #	3 core intercooler system upgrade	from 2 core	-	3" tubing	+\$435

**FOR COYOTE & GODZILLA ENGINE SWAP KITS, SEE PAGE 24**

# SPECIFICATIONS (2005-10 MUSTANG)

## 2005-10 MUSTANG GT (4.6 3V) SPECIFICATIONS

Year	Part Number	OEM hp Rating	HP Gain	Tube Diam	Intercooler Mount	Drive System	Bypass System	Fuel System Upgrade	Fuel Inj. Supplied	Computer/Ignition Modifications	Supercharger Warranty (in months)	CARB E.O.	Foot Notes
2005-10	1FP311-SCI	300	Call	2.5-3"	V	stk 6 rib	ProFlow	in-tank pump	39.5 lb/hr	programmer supplied	12, 36 opt. (\$99)	Call	D1, D2
2005-10	1FP301-SCI	300	Call	2.5-3"	V	stk 6 rib	ProFlow	not supplied	No	not supplied	12	-	D1
2005-10	1FP214-SCI	300	70-75%	2.5-3"	V	add'l 8 rib	ProFlow	in-tank pump	39.5 lb/hr	programmer supplied	12, 36 opt. (\$99)	-	D1, D2, D8
2005-10	1FP204-SCI	300	specify	2.5-3"	V	add'l 8 rib	ProFlow	not supplied	No	not supplied	12	-	D1, D8
2005-09	1FP211-SCI	300	70-75%	3"	V	add'l 8 rib	ProFlow	in-tank pump	39.5 lb/hr	programmer supplied	12, 36 opt. (\$99)	-	D1, D2, D6, D7
2005-09	1FP202-SCI	300	specify	3"	V	add'l 8 rib	ProFlow	not supplied	No	not supplied	12	-	D1, D6, D7
2005-09	1FP213-F1	-	specify	3"	V	add'l 12 rib	Race	not supplied	No	not supplied	12	-	D1, D3, D4, D5, D7

## 2005-10 MUSTANG V6 (4.0) SPECIFICATIONS

Year	Part Number	OEM hp Rating	HP Gain	Tube Diam	Intercooler Mount	Drive System	Bypass System	Fuel System Upgrade	Fuel Inj. Supplied	Computer/Ignition Modifications	Supercharger Warranty (in months)	CARB E.O.	Foot Notes
2005-10	1FQ212-SCI	220	55-60%	3"	V	stk 6 rib	ProFlow	not required	39.5 lb/hr	programmer supplied	12, 36 opt. (\$99)	-	D1, D2, D9, D10
2005-10	1FQ202-SCI	220	specify	3"	V	stk 6 rib	ProFlow	not supplied	No	not supplied	12	-	D1, D10

### FORD AUTOMOTIVE FOOTNOTES (specific to above applications):

- D1) Model year must be specified
- D2) Due to variability among OEM computers, the prevalence of custom modifications, and age/miles/condition of vehicles, dyno tuning may be required; Stock vehicles with cat-back exhaust systems may also require custom tuning
- D3) Modified engines only
- D4) Inner fender modification required
- D5) Requires use of ATI Performance Products aftermarket balancer, part #918039 (not included - specify hardened hub)
- D6) System ships in extra large box
- D7) 800+ hp intercooler may require trimming of plastic bumper cover (behind bumper, not visible)
- D8) Fog lights may need to be removed on 2010 Mustang GT's
- D9) ECM code required
- D10) Special order kit: order form and non-refundable deposit required at time of order—may require additional lead time for processing





**1999-04 MUSTANG GT AND 2001 BULLITT (4.6 2V) SYSTEMS AND KITS**

Year	Part Number	Description	Boost Options	HP Gain	Intercooler	Price/MAP
1999-04	1FE212-SCI	High Output Intercooled System with P-1SC	8 psi	55-60%	2 core	\$6,749
1999-04	1FE202-SCI	High Output Intercooled Tuner Kit with P-1SC	specify	specify	2 core	\$5,799
1999-04	1FE211-SCI	Stage II Intercooled System with P-1SC	8 psi	60-65%	3 core	\$7,099
1999-04	1FE201-SCI	Stage II Intercooled Tuner Kit with P-1SC	specify	specify	3 core	\$6,049
2001 BULLITT	add "-B" to part # above	Same as 1999-04 Mustang GT	see above	see above	see above	see above

**2003-04 MUSTANG MACH 1 (4.6 4V) SYSTEMS AND KITS**

Year	Part Number	Description	Boost Options	HP Gain	Intercooler	Price/MAP
2003-04	1FL212-SCI	Stage II Intercooled System with P-1SC	8 psi	60-65%	3 core	\$7,999
2003-04	1FL202-SCI	Stage II Intercooled Tuner Kit with P-1SC	specify	specify	3 core	\$6,949

<b>1999-04 MUSTANG GT, BULLITT &amp; MACH 1 OPTIONS</b>	add "-B" or "-P" to part #	Black or Polished finish for ProCharger (P-series or D-series, head unit only)	satin standard	-	-	+\$325
	add "-B" or "-P" to part #	Black or Polished finish for ProCharger (F-series, 9" or 9.75" housing)	satin standard	-	-	+\$350
	add "-H" to part #	Helical gasket for noise reduction (P-1SC, D-1SC)	same	same	-	+\$110
	add "-D1SC" to part #	With D-1SC ProCharger (replacing P-1SC)	tuner kit only	specify	-	+\$495
	add "-D" or "-1" or "-A"	With F-1D, F-1, F-1A (replacing P-1SC)	tuner kit only	specify	-	+\$1,095
	add "-RVR" or "-RVB"	Race Bypass Valve Upgrade (specify open or closed valve; Kits only; red or black)	from ProFlow	specify	-	+\$295
	add "-3C" to part #	3 core intercooler system upgrade	from 2 core	825 hp max	3" tubing	+\$435
add "-SM" to part #	Sheet metal 3 core race intercooler upgrade	from 3 core	950 hp max	3" tubing	+\$295	

**1996-98 MUSTANG GT (4.6 2V) SYSTEMS AND KITS**

Year	Part Number	Description	Boost Options	HP Gain	Intercooler	Price/MAP
1996-98	1FD211-10I	High Output Intercooled System with P-1SC	8, 10 psi	55-70%	2 core	\$6,099
1996-98	1FD201-SCI	High Output Intercooled Tuner Kit with P-1SC	specify	specify	2 core	\$5,799
1996-98	1FD212-SCI	Stage II Intercooled System with P-1SC	8, 10, 12 psi	60-80%	3 core	\$6,499
1996-98	1FD202-SCI	Stage II Intercooled Tuner Kit with P-1SC	specify	specify	3 core	\$6,149

<b>1996-98 MUSTANG GT OPTIONS</b>	add "-B" or "-P" to part #	Black or Polished finish for ProCharger (P-series or D-series, head unit only)	satin standard	-	-	+\$325
	add "-H" to part #	Helical gasket for noise reduction (P-1SC, D-1SC)	same	same	-	+\$110
	add "-D1SC" to part #	With D-1SC ProCharger (replacing P-1SC)	tuner kit only	specify	-	+\$495
	add "-3C" to part #	3 core intercooler system upgrade	from 2 core	825 hp max	3" tubing	+\$435
	add "-SM" to part #	Sheet metal 3 core race intercooler upgrade	from 3 core	950 hp max	3" tubing	+\$295

**1994-04 MUSTANG V6 (3.8, 3.9) SYSTEMS AND KITS**

Year	Part Number	Description	Boost Options	HP Gain	Intercooler	Price/MAP
1999-03	1FI202-SCI	Stage II Intercooled System with P-1SC	9, 11 psi	60-80%	2 core	\$6,199
1999-04	1FI200-SCI	Intercooled Tuner Kit with P-1SC	specify	specify	2 core	\$5,599
1994-98	1FJ212-SCI	High Output Intercooled System with P-1SC	11 psi	75-80%	2 core	\$5,399
1994-98	1FJ202-SCI	High Output Intercooled Tuner Kit with P-1SC	specify	specify	2 core	\$5,049

<b>1994-04 MUSTANG V6 (3.8, 3.9)</b>	add "-B" or "-P" to part #	Black or Polished finish for ProCharger (P-series or D-series)	satin standard	-	-	+\$325
	add "-H" to part #	Helical gasket for noise reduction (P-1SC, D-1SC)	same	same	-	+\$110
	add "-D1SC" to part #	With D-1SC ProCharger (replacing P-1SC)	tuner kit only	-	-	+\$495
	add "-3C" to part #	3 core intercooler system upgrade	from 2 core	825 hp max	3" tubing	+\$435

**FOR COYOTE & GODZILLA ENGINE SWAP KITS, SEE PAGE 24**

# SPECIFICATIONS (1994-04 MUSTANG)

## 1999-04 MUSTANG GT AND 2001 BULLITT (4.6 2V) SPECIFICATIONS

Year	Part Number	OEM hp Rating	HP Gain	Tube Diam	IC Mount	Drive System	Bypass System	Fuel System Upgrade	Fuel Inj. Supplied	Computer/Ignition Modifications	Supercharger Warranty (in months)	CARB E.O.	Foot Notes
1999-04	1FE212-SCI	260	55-60%	3"	V	stk 6 rib	ProFlow	not required	39.5 lb/hr	programmer supplied	12, 36 opt. (\$99)	D-365-5	E1, E5
1999-04	1FE202-SCI	260	specify	3"	V	stk 6 rib	ProFlow	not supplied	No	not supplied	12	-	E1, E6, E14
1999-04	1FE211-SCI	260	60-65%	3"	V	stk 6 rib	ProFlow	in-tank pump	39.5 lb/hr	programmer supplied	12, 36 opt. (\$99)	-	E1, E3, E5
1999-04	1FE201-SCI	260	specify	3"	V	stk 6 rib	ProFlow	not supplied	No	not supplied	12	-	E1, E6, E14
2001	BULLITT	265	55-60%	3"	V	stk 6 rib	ProFlow	As above	As above	As above	As above	D-365-5	As Above

## 2003-04 MUSTANG MACH 1 (4.6 4V) SPECIFICATIONS

Year	Part Number	OEM hp Rating	HP Gain	Tube Diam	IC Mount	Drive System	Bypass System	Fuel System Upgrade	Fuel Inj. Supplied	Computer/Ignition Modifications	Supercharger Warranty (in months)	CARB E.O.	Foot Notes
2003-04	1FL212-SCI	300	60-65%	3"	V	stk 6 rib	ProFlow	in-tank pump	39.5 lb/hr	programmer supplied	12, 36 opt. (\$99)	Call	E1, E3, E5, E13
2003-04	1FL202-SCI	300	specify	3"	V	stk 6 rib	ProFlow	not supplied	No	not supplied	12	-	E1, E13

## 1996-98 MUSTANG GT (4.6 2V) SPECIFICATIONS

Year	Part Number	OEM hp Rating	HP Gain	Tube Diam	IC Mount	Drive System	Bypass System	Fuel System Upgrade	Fuel Inj. Supplied	Computer/Ignition Modifications	Supercharger Warranty (in months)	CARB E.O.	Foot Notes
1996-98	1FD211-101	215-225	55-70%	3"	V	stk 6 rib	ProFlow	ProPump, FMU	not required	not required	12, 36 opt. (\$99) @ 8 psi	D-365-3 (10 psi)	E1, E5, E13
1996-98	1FD201-SCI	215-225	specify	3"	V	stk 6 rib	ProFlow	not supplied	No	not required	12	-	E1, E5, E13
1996-98	1FD212-SCI	215-225	60-80%	3"	V	stk 6 rib	ProFlow	ProPump, FMU	not supplied	not required	12, 36 opt. (\$99) @ 8 psi	-	E1, E2 (12 psi), E5, E13
1996-98	1FD202-SCI	215-225	specify	3"	V	stk 6 rib	ProFlow	not supplied	No	not required	12	-	E1, E2 (12 psi), E5, E13

## 1994-04 MUSTANG V6 (3.8, 3.9) SPECIFICATIONS

Year	Part Number	OEM hp Rating	HP Gain	Tube Diam	IC Mount	Drive System	Bypass System	Fuel System Upgrade	Fuel Inj. Supplied	Computer/Ignition Modifications	Supercharger Warranty (in months)	CARB E.O.	Foot Notes
1999-03	1FJ202-SCI	193	60-80%	3"	V	stk 6 rib	ProFlow	in-tank pump	39.5 lb/hr	programmer supplied	12, 36 opt. (\$99) @ 9 psi	-	E1, E3, E9, E13
1999-04	1FI200-SCI	193	specify	3"	V	stk 6 rib	ProFlow	not supplied	No	not supplied	12	-	E1, E9, E12, E13
1994-98	1FJ212-SCI	145	75-80%	3"	V	stk 6 rib	ProFlow	ProPump, FMU	not required	not required	12, 36 opt. (\$99)	D-365-3	E1, E11, E13
1994-98	1FJ202-SCI	145	specify	3"	V	stk 6 rib	ProFlow	not supplied	No	not required	12	-	E1, E11, E13

## FORD AUTOMOTIVE FOOTNOTES (specific to above applications):

- E1) Model year must be specified
- E2) 24 lb/hr fuel injectors required (not supplied)
- E3) Due to variability among OEM computers, the prevalence of custom modifications, and age/miles/condition of vehicles, dyno tuning may be required; Stock vehicles with cat-back exhaust systems may also require custom tuning
- E5) Aftermarket mass air sensors will require custom tuning
- E6) D-1SC, F-1, F-1A modified motors only (air inlet may require modification)
- E9) 1999-01 3.8 Mustangs must specify if car is equipped with ABS/Traction control
- E11) 1994-98 3.8 Mustangs with ABS/Traction control module will require custom relocation of that module
- E12) Tuner kits available for 2004 Mustang V6 3.9L models; custom tuning required
- E13) Special order kit: order form and non-refundable deposit required at time of order—may require additional lead time for processing
- E14) Race valve requires welding



**2003-04 COBRA (4.6 4V) KITS**

Year	Part Number	Description	Boost Options	Max RWHP	Intercooler	Price/MAP
2003-04	1FM202-SC	High Output Tuner Kit with P-1SC-2	10-15 psi	550 rwhp	OEM supplied	\$5,599
2003-04	1FM203-SC	Stage II Tuner Kit with F-1D, F-1, or F-1A (6 rib)	10-20 psi	620 rwhp	OEM supplied	\$6,149
2003-04	1FM204-SC-C	Race Kit with F-1D, F-1, or F-1A (cog drive)	18-30+ psi	750+ rwhp	OEM supplied	\$6,699

<b>2003-04 COBRA (4V)</b>	add "-B" or "-P" to part #	Black or Polished finish for ProCharger (P-series or D-series, head unit only)	satin standard	-	-	+\$325
	add "-PI" to part #	Polished finish for sheet metal intake	satin standard	-	-	+\$350
	add "-O" to part #	Omit Cobra intake manifold	-	-	-	-\$659

**1999-01 COBRA (4.6 4V) SYSTEMS AND KITS**

Year	Part Number	Description	Boost Options	HP Gain	Intercooler	Price/MAP
1999-01	1FF211-SCI	High Output Intercooled System with P-1SC	6 psi max	45-50%	2 core	\$7,499
1999-01	1FF201-SCI	High Output Intercooled Tuner Kit with P-1SC	specify	specify	2 core	\$6,499
1999-01	1FF212-SCI	Stage II Intercooled System with P-1SC	8 psi	60-65%	3 core	\$7,849
1999-01	1FF202-SCI	Stage II Intercooled Tuner Kit with P-1SC	specify	specify	3 core	\$6,699

<b>1999-01 COBRA (4V) OPTIONS</b>	add "-B" or "-P" to part #	Black or Polished finish for ProCharger (P-series or D-series, head unit only)	satin standard	-	-	+\$325
	add "-H" to part #	Helical gearset for noise reduction (P-1SC, D-1SC)	same	same	-	+\$110
	add "-D1SC" to part #	With D-1SC ProCharger (replacing P-1SC)	tuner kit only	specify	-	+\$495
	add "-3C" to part #	3 core intercooler system upgrade (HO system only)	from 2 core	825 hp max	3" tubing	+\$435
	add "-SM" to part #	Sheet metal 3 core race intercooler upgrade	from 3 core	950 hp max	3" tubing	+\$345

**1996-98 COBRA (4.6 4V) SYSTEMS AND KITS**

Year	Part Number	Description	Boost Options	HP Gain	Intercooler	Price/MAP
1996-98	1FC211-10I	HO Intercooled System with P-1SC	6 psi	45-50%	2 core	\$7,249
1996-98	1FC201-SCI	HO Intercooled Tuner Kit with P-1SC	specify	specify	2 core	\$6,349
1996-98	1FC212-SCI	Stage II Intercooled System with P-1SC	8 psi	60-65%	3 core	\$7,599
1996-98	1FC202-SCI	Stage II Intercooled Tuner Kit with P-1SC	specify	specify	3 core	\$6,699

<b>1996-98 COBRA (4V) OPTIONS</b>	add "-B" or "-P" to part #	Black or Polished finish for ProCharger (P-series or D-series, head unit only)	satin standard	-	-	+\$325
	add "-H" to part #	Helical gearset for noise reduction (P-1SC, D-1SC)	same	same	-	+\$110
	add "-D1SC" to part #	With D-1SC ProCharger (replacing P-1SC)	tuner kit only	specify	-	+\$495
	add "-SM" to part #	Sheet metal 3 core race intercooler upgrade	from 3 core	950 hp max	3" tubing	+\$345

**1996-98 COBRA (4.6 4V) RACE KITS**

Year	Part Number	Description	Boost Options	HP Gain	Intercooler	Price/MAP
1996-98	1FX205-F1A	Serpentine Race Kit with F-1D, F-1, or F-1A (additional 8 rib)	specify	specify	-	\$6,699
1996-98	1FX244-F1C	Coq Race Kit with F-1C or F-1R	specify	specify	-	\$7,399

<b>1996-98 COBRA (4V) RACE KIT OPTIONS</b>	add "-B" or "-P" to part #	Black or Polished finish for ProCharger (F-series, 9" or 9.75" housing, head unit only)	satin standard	-	-	+\$350
	add "-B" or "-P" to part #	Black or Polished finish for ProCharger (10.5" housing, head unit only)	satin standard	-	-	+\$375
	add "-C" or "-R" to part #	With F-1C or F-1R ProCharger (replacing F-1D, F-1, F-1A)	specify	specify	-	+\$350
	add "-F2" to part #	With F-2 ProCharger (replacing F-1C, F-1R)	cog kit only	specify	-	+\$1,465
	AI045A-001	Sheet metal 3 core race intercooler (1300 hp)	-	3.5" in/outlet	-	+\$1,798
	WI1005A-001	Air/water intercooler (race use only)	-	1,800 hp max	-	+\$2,498

**FOR COYOTE & GODZILLA ENGINE SWAP KITS, SEE PAGE 24**



# SPECIFICATIONS (1996-04 COBRA)

## 2003-04 COBRA (4.6 4V) SPECIFICATIONS

Year	Part Number	OEM hp Rating	HP Gain	Tube Diam	Intercooler Mount	Drive System	Bypass System	Fuel System Upgrade	Fuel Inj. Supplied	Computer/Ignition Modifications	Supercharger Warranty (in months)	CARB E.O.	Foot Notes
2003-04	1FM202-SC	390	specify	-	-	stk 6 rib	ProFlow	not required	No	not supplied	12	-	F1, F10
2003-04	1FM203-SC	390	specify	-	-	stk 6 rib	Race	not supplied	No	not supplied	12	-	F1, F10
2003-04	1FM204-SC-C	390	specify	-	-	cog	Race	not supplied	No	not supplied	Limited	-	F1, F9, F10

## 1999-01 COBRA (4.6 4V) SPECIFICATIONS

Year	Part Number	OEM hp Rating	HP Gain	Tube Diam	Intercooler Mount	Drive System	Bypass System	Fuel System Upgrade	Fuel Inj. Supplied	Computer/Ignition Modifications	Supercharger Warranty (in months)	CARB E.O.	Foot Notes
1999-01	1FF211-SCI	320	45-50%	3"	V	stk 6 rib	ProFlow	not required	39.5 lb/hr	programmer supplied	12, 36 opt. (\$99)	-	F1, F2, F3
1999-01	1FF201-SCI	320	specify	3"	V	stk 6 rib	ProFlow	not supplied	No	not supplied	12	-	F1, F3, F4
1999-01	1FF212-SCI	320	60-65%	3"	V	stk 6 rib	ProFlow	in-tank pump	39.5 lb/hr	programmer supplied	12, 36 opt. (\$99)	Call	F1, F2, F4
1999-01	1FF202-SCI	320	specify	3"	V	stk 6 rib	ProFlow	not supplied	No	not supplied	12	-	F1, F4

## 1996-98 COBRA (4.6 4V) SPECIFICATIONS

Year	Part Number	OEM hp Rating	HP Gain	Tube Diam	Intercooler Mount	Drive System	Bypass System	Fuel System Upgrade	Fuel Inj. Supplied	Computer/Ignition Modifications	Supercharger Warranty (in months)	CARB E.O.	Foot Notes
1996-98	1FC211-10I	305	45-50%	3"	V	stk 6 rib	ProFlow	ProPump, FMU	No	programmer supplied	12, 36 opt. (\$99)	D-365-3	F1, F5, F10
1996-98	1FC201-SCI	305	specify	3"	V	stk 6 rib	ProFlow	not supplied	No	not supplied	12	-	F1, F10
1996-98	1FC212-SCI	305	60-65%	3"	V	stk 6 rib	ProFlow	ProPump, FMU	No	programmer supplied	12, 36 opt. (\$99)	-	F1, F2, F5, F10
1996-98	1FC202-SCI	305	specify	3"	V	stk 6 rib	ProFlow	not supplied	No	not supplied	12	-	F1, F10

## 1996-98 COBRA (4.6 4V) RACE SPECIFICATIONS

Year	Part Number	OEM hp Rating	HP Gain	Tube Diam	Intercooler Mount	Drive System	Bypass System	Fuel System Upgrade	Fuel Inj. Supplied	Computer/Ignition Modifications	Supercharger Warranty (in months)	CARB E.O.	Foot Notes
1996-98	1FX205-F1A	n/a	specify	-	-	add'l 8 rib	Race	not supplied	No	not supplied	12	-	F6, F8, F10
1996-98	1FX244-F1C	n/a	specify	-	-	cog	Race	not supplied	No	not supplied	Limited	-	F1, F6, F7, F8, F10

## FORD AUTOMOTIVE FOOTNOTES (specific to above applications):

- F1) Model year must be specified
- F2) Due to variability among OEM computers, the prevalence of custom modifications, and age/miles/condition of vehicles, dyno tuning may be required
- F3) HO Systems and Tuner Kits for 1996-01 Cobras require a cut-down impeller, which limits max boost to 8 psi on stock motors
- F4) 1999-01 model years with over 10 psi boost require Ford Lightning (flange-style) MAF (not supplied)
- F5) 30 lb/hr fuel injectors required (not supplied)
- F6) Modified motors only
- F7) May require cooling system and air conditioning system modifications
- F8) ATI Performance Products aftermarket balancer required, part #918036 (not included - specify hardened hub)
- F9) Battery relocation required (trunk relocation kit supplied)
- F10) Special order kit: order form and non-refundable deposit required at time of order—may require additional lead time for processing



**1994-95 MUSTANG AND COBRA (5.0) SYSTEMS AND KITS**

Year	Part Number	Description	Boost Options	HP Gain	Intercooler	Price/MAP
1994-95	<b>1FB100-091 / 111 / 141</b>	<b>High Output Intercooled System with P-1SC</b>	9, 11, 14 psi	60-85%	2 core	\$6,049
1994-95	1FB202-SCI	<b>High Output Intercooled Tuner Kit with P-1SC</b>	specify	specify	2 core	\$5,749
1994-95	<b>1FB324-D1SC</b>	<b>Stage II Intercooled System with D-1SC</b>	15-22 psi	85%+	3 core	\$6,849
1994-95	1FB012-SC1	High Output Kit with P-1SC	specify	specify	-	\$4,949

<b>1994-95 MUSTANG &amp; COBRA (5.0) OPTIONS</b>	add "-B" or "-P" to part #	Black or Polished finish for ProCharger (P-series or D-series, head unit only)	satin standard	-	-	+\$325
	add "-B" or "-P" to part #	Black or Polished finish for ProCharger (F-series, 9" or 9.75" housing)	satin standard	-	-	+\$350
	add "-H" to part #	Helical gearset for noise reduction (P-1SC, D-1SC)	same	same	-	+\$110
	add "-P1SC1" to part #	With P-1SC-1 ProCharger (replacing P-1SC)	specify	specify	-	+\$220
	add "-P1X" to part #	With P-1X ProCharger (replacing P-1SC)	specify	specify	-	+\$470
	add "-D1SC" to part #	With D-1SC ProCharger (replacing P-1SC)	specify	specify	-	+\$495
	add "-D" or "-1" or "-A"	With F-1D, F-1, F-1A ProCharger (replacing D-1SC, Stage II only)	specify	specify	-	+\$599
	add "-RVR" or "RVB"	Race Bypass Valve Upgrade (specify open or closed valve; red or black)	from ProFlow	specify	-	+\$295
	add "-3C" to part #	3 core intercooler system upgrade	from 2 core	825 hp max	3" tubing	+\$435
	add "-SM" to part #	Sheet metal 3 core race intercooler upgrade	from 3 core	950 hp max	3" tubing	+\$295
add "-OF" to part #	Omit FMU (from Stage II)	-	-	-	-\$88	
add "-OP" to part #	Omit in-line fuel pump (from Stage II)	-	-	-	-\$98	

**1986-93 MUSTANG AND COBRA (5.0) SYSTEMS AND KITS**

Year	Part Number	Description	Boost Options	HP Gain	Intercooler	Price/MAP
1986-93	<b>1FA100-091 / 111 / 141</b>	<b>High Output Intercooled System with P-1SC (8 rib)</b>	9, 11, 14 psi	60-85%	2 core	\$5,949
1986-93	1FA202-SCI	<b>High Output Intercooled Tuner Kit with P-1SC (8 rib)</b>	specify	specify	2 core	\$5,649
1986-93	<b>1FA324-D1SC-8R</b>	<b>Stage II Intercooled System with D-1SC (8 rib)</b>	15-25 psi	85%+	3 core	\$6,749
1986-93	1FA012-SC	High Output Kit with P-1SC	specify	specify	-	\$4,799

<b>1986-93 MUSTANG &amp; COBRA (5.0) OPTIONS</b>	add "-B" or "-P" to part #	Black or Polished finish for ProCharger (P-series or D-series)	satin standard	-	-	+\$325
	add "-B" or "-P" to part #	Black or Polished finish for ProCharger (F-series, 9" or 9.75" housing)	satin standard	-	-	+\$350
	add "-BB" or "-PB" to part #	Black or Polished finish for supercharger bracket	satin standard	-	-	+\$275
	add "-H" to part #	Helical gearset for noise reduction (P-1SC, D-1SC)	same	same	-	+\$110
	add "-P1SC1" to part #	With P-1SC-1 ProCharger (replacing P-1SC)	specify	specify	-	+\$220
	add "-P1X" to part #	With P-1X ProCharger (replacing P-1SC)	specify	specify	-	+\$470
	add "-D1SC" to part #	With D-1SC ProCharger (replacing P-1SC)	specify	specify	-	+\$495
	add "-D" or "-1" or "-A"	With F-1D, F-1, F-1A ProCharger (replacing D-1SC)	specify	specify	-	+\$599
	add "-12R" to part #	12 rib drive system upgrade (Stage II only)	specify	specify	-	+\$260
	AV006A-003	Bullet bypass valve kit (from ProFlow, HO Intercooled Systems/Kits only)	-	-	-	+\$125
	add "-3C" to part #	3 core intercooler system upgrade	from 2 core	825 hp max	3" tubing	+\$435
	add "-THF" to part #	Twin Highflow intercooler upgrade	from 3 core	850 hp max	2.5-3" tubing	+\$295
	add "-SM" to part #	Sheet metal 3 core race intercooler upgrade	from 3 core	950 hp max	3" tubing	+\$295
	add "-OF" to part #	Omit FMU (from Stage II)	-	-	-	-\$88
add "-OP" to part #	Omit in-line fuel pump (from Stage II)	-	-	-	-\$98	
AB003A-010	Alternator relocation kit with power steering (non A/C vehicles)	-	-	-	+\$545	

**FOR COYOTE & GODZILLA ENGINE SWAP KITS, SEE PAGE 24**

# SPECIFICATIONS (1986-95 MUSTANG AND COBRA)

## 1994-95 MUSTANG, COBRA (5.0) SPECIFICATIONS

Year	Part Number	OEM hp Rating	HP Gain	Tube Diam	IC Mount	Drive System	Bypass System	Fuel System Upgrade	Fuel Inj. Supplied	Computer/Ignition Modifications	Supercharger Warranty (in months)	CARB E.O.	Foot Notes
1994-95	1FB100-091 / 111 / 141	215/240	60-85%	3"	V	stk 6 rib	ProFlow	ProPump, FMU	not req.	not required	12, 36 opt. (\$99) @ 9 psi	D-365-3	G1, G2, G3, G4, G5, G10
1994-95	1FB202-SCI	215/240	specify	3"	V	stk 6 rib	ProFlow	not supplied	not req.	not required	12	-	G1, G2, G3, G4, G5, G10
1994-95	1FB324-D1SC	215/240	85%+	3"	V	stk 6 rib	ProFlow	ProPump, FMU	No	not required	12	-	G1, G2, G3, G4, G5, G10
1994-95	1FB012-SC1	215/240	specify	-	-	stk 6 rib	ProFlow	ProPump, FMU	No	not supplied	12	-	G1, G2, G3, G4, G5, G10

## 1986-93 MUSTANG, COBRA (5.0) SPECIFICATIONS

Year	Part Number	OEM hp Rating	HP Gain	Tube Diam	IC Mount	Drive System	Bypass System	Fuel System Upgrade	Fuel Inj. Supplied	Computer/Ignition Modifications	Supercharger Warranty (in months)	CARB E.O.	Foot Notes
1986-93	1FA100-091 / 111 / 141	205-235	60-85%	3"	V / H	add'l 8 rib	ProFlow	ProPump, FMU	not req.	not required	12, 36 opt. (\$99) @ 9 psi	D-365-3	G1, G2, G6, G9, G12
1986-93	1FA202-SCI	205-235	specify	3"	V / H	add'l 8 rib	ProFlow	not supplied	not req.	not required	12	-	G1, G2, G6, G9, G12
1986-93	1FA324-D1SC-8R	205-235	85%+	3"	V / H	add'l 8 rib	ProFlow	ProPump, FMU	No	not required	12	-	G1, G2, G6, G7, G9, G11, G12
1986-93	1FA012-SC	205-235	specify	3"	-	add'l 8 rib	ProFlow	FMU	No	not supplied	12	-	G1, G2, G8, G9, G12

## FORD AUTOMOTIVE FOOTNOTES (specific to above applications):

- G1) Model year must be specified
- G2) Standard ProCharger bracket requires factory a/c and p/s
- G3) Specify stock or bullet-style MAF flange
- G4) Battery relocation required (trunk relocation kit supplied)
- G5) Cobra balancer must be replaced with GT balancer, Ford part #F4ZZ6A312A (not supplied)
- G6) GT models can have either vertical or horizontal intercooler mounting; horizontal intercooler or Twin Highflow mounting recommended for LX models; vertical mounting possible with modifications; vertical mounting or Twin Highflow recommended for all lowered vehicles.
- G7) Inner fender modification may be required
- G8) Specify stock or cowl hood (additional charge for stock hood—requires alternate tubing)
- G9) For speed density models (most 1986-88) MAF conversion is recommended (not supplied)
- G10) Special order kit: order form and non-refundable deposit required at time of order—may require additional lead time for processing
- G11) 12-rib kits may require modifications/trimming.
- G12) Non A/C vehicles require power steering relocation kit (AB003A-010)





**CARBURETED AND AFTERMARKET EFI FORD SB SERPENTINE KITS (WINDSOR/YATES BASED, 85-93 MUSTANG ACCESSORIES)**

Year	Part Number	Description	Boost Options	HP Gain	Intercooler	Price/MAP
1985-93	1FX012-P1SC	High Output Kit with P-1SC (8 rib)	specify	specify	-	\$4,749
1985-93	1FX212-P1SC-I	<b>High Output Intercooled Kit with P-1SC (8 rib)</b>	specify	specify	2 core (550hp)	\$5,849
1985-93	1FX013-P1SC2	High Output Kit with P-1SC-2 (8 rib)	specify	specify	-	\$4,949
1985-93	1FX022-D1SC	High Output Kit with D-1SC (12 rib)	specify	specify	-	\$5,399
1985-93	1FX222-D1SC-I	<b>High Output Intercooled Kit with D-1SC (12 rib)</b>	specify	specify	3 core (825hp)	\$6,599
1985-93	1FX024-F1A94/F1C/F1R	8 rib Race Kit with F-1A-94, F-1C or F-1R (EFI Renegade)	specify	specify	-	\$6,599
1985-93	1FX124-F1D/F1F/F1A	High Output Kit with F-1D, F-1, or F-1A (12 rib)	specify	specify	-	\$6,549
1985-93	1FX324-F1D-I/F1F-I/F1A-I	<b>High Output Intercooled Kit with F-1D, F-1, or F-1A (12 rib)</b>	specify	specify	Sht mtl 3C (950hp)	\$8,149
1985-93	1FX022-F1A94/F1C/F1R	High Output Kit with F-1A-94, F-1C or F-1R (12 rib)	specify	specify	-	\$7,099
1985-93	1FX124-F1A94-I/F1C-I/F1R-I	<b>High Output Intercooled Kit with F-1A-94, F-1C or F-1R (12 rib)</b>	specify	specify	Sht mtl 3C (1050hp)	\$8,399

**1964<sup>1</sup>/<sub>2</sub>-66 MUSTANG AND EARLY FORD (289, 302, 351 V8) KITS**

Year	Part Number	Description	Boost Options	HP Gain	Intercooler	Price/MAP
1964.5-66	1FX400-P1SC	High Output Kit with P-1SC (8 rib)	specify	specify	-	\$4,849
1964.5-66	1FX400-P1SC-I	<b>High Output Intercooled Kit with P-1SC (8 rib)</b>	specify	specify	2 core (550hp)	\$5,999

CARB & AFTERMARKET EFI FORD SB SERPENTINE KIT OPTIONS	add "-B" or "-P" to part #	Black or Polished finish for ProCharger (P-series or D-series)	satin standard	-	-	+\$325
	add "-B" or "-P" to part #	Black or Polished finish for ProCharger (F-series 9"-9.75" housing)	satin standard	-	-	+\$350
	add "-BB" or "-PB" to part #	Black or Polished finish for supercharger bracket	satin standard	-	-	+\$275
	add "-BC" or "-PC" to part #	Black or Polished finish for carburetor bonnet	satin standard	-	-	+\$100
	add "-BPPB" or "-PPB" to part #	Black or Polished finish for Power Steering Bracket	satin standard	-	-	+\$175
	add "-BAB" or "-PAB" to part #	Black or Polished finish for Alternator Bracket	satin standard	-	-	+\$170
	add "-H" to part #	Helical gearset for noise reduction (P-1SC, D-1SC)	same	same	-	+\$110
	add "-P1X" to part #	With P-1X ProCharger (replacing P-1SC)	same	add'l 10-15+ hp	-	+\$470
	add "-D1X" to part #	With D-1X ProCharger (replacing P-1SC)	tuner kit only	specify	-	+\$695
	add "-D1SC" to part #	With D-1SC ProCharger (replacing P-1SC)	-	specify	-	+\$495
	add "-D1X" to part #	With D-1X ProCharger (replacing D-1SC)	tuner kit only	specify	-	+\$200
	add "-D" or "-1" or "-A"	With F-1D, F-1, F-1A ProCharger (replacing P-1SC)	-	specify	-	+\$1,095
	add "-94"	With F-1A-94 ProCharger (replacing P-1SC)	-	-	-	+\$1,445
	3FXSS-003	ProFlow bypass valve kit	-	-	-	+\$268
	AV006A-003	Bullet bypass valve kit	-	-	-	+\$388
	3FASS-00X	Race Bypass Valve, Open or Closed (specify alum. or steel flange)	red or black	-	-	+\$498
	add "-CB" to part #	Competition carb bonnet upgrade	from standard	-	-	+\$50
	AB003A-010	Alternator relocation kit with power steering	satin finish only	-	-	+\$545
	AI003A-001	3 core intercooler (825 hp)	from non-ic kit	3" in/outlet	-	+\$1,198
	AI003A-002	Sheet metal 3 core race intercooler (950 hp)	from non-ic kit	3" in/outlet	-	+\$1,398
	AI003A-005	Sheet metal 3 core race intercooler (1050 hp)	from non-ic kit	3.5" in/outlet	-	+\$1,498
	AI045A-001	Sheet metal 3 core race intercooler (1300 hp)	from non-ic kit	3.5" in/outlet	-	+\$1,798
	AI003A-001	3 Core Intercooler Upgrade (825 hp)	from 2 core	3" in/outlet	-	+\$435
	AI003A-002	Air-to-Air Race Intercooler Upgrade (950 hp)	from 2 core	3" in/outlet	-	+\$635
	3FAAT-003	Alternator Bracket (Requires 1985-93 Alternator) 64.5-66 Only	-	-	-	+\$495
	FV001I-BST	Boost sensitive fuel pressure regulator (EFI or Carb)	-	-	-	+\$285
	FV002I-BST	Boost sensitive fuel pressure regulator (Carb only, 1000hp capable)	-	-	-	+\$315
	FP001I-002	ProPump fuel pump 700 hp	-	-	-	+\$330
FP001I-006	High performance 1000 hp electric fuel pump	-	-	-	+\$438	
add "-NB"	1964.5-73 Narrow engine bay 8 rib Bracket (non A/C)	from std bracket	-	-	+\$75	

**FOR COYOTE & GODZILLA ENGINE SWAP KITS, SEE PAGE 24**

# SPECIFICATIONS (CARB AND AFTERMARKET EFI SMALL BLOCK)

## CARBURETED, AFTERMARKET EFI FORD SB SERPENTINE KITS (WINDSOR/YATES BASED, 1985-93 MUSTANG ACCESSORIES) SPECIFICATIONS

Year	Part Number	HP Gain	Tube Diam	Carb Hat	Drive System	Bypass Valve	Alternator Relocation Kit	Alternator with P/S Relocation Kit	Tubing Supplied	SC Warranty (in months)	Foot Notes
1985-93	1FX012-P1SC	specify	-	Low profile	add'l 8 rib	Sold separately	Optional	Optional	-	12	H1, H5, H6, H7
1985-93	1FX212-P1SC-I	specify	3"	Standard	add'l 8 rib	ProFlow	Optional	Optional	Yes	12	H1, H2, H5, H6, H7
1985-93	1FX013-P1SC2	specify	-	Low profile	add'l 8 rib	Sold separately	Optional	Optional	-	12	H1, H5, H6, H7
1985-93	1FX022-D1SC	specify	-	Standard	add'l 12 rib	Sold separately	Optional	Optional	-	12	H1, H5, H6, H7
1985-93	1FX222-D1SC-I	specify	3"	Standard	add'l 12 rib	ProFlow	Optional	Optional	Yes	12	H1, H2, H5, H6, H7
1985-93	1FX024-F1A94/F1C/F1R	specify	-	-	add'l 8 rib	Race Valve	N/A	N/A	-	12	H1, H4, H5, H6, H7
1985-93	1FX124-F1D/F1F/F1A	specify	-	Standard	add'l 12 rib	Race Valve	Optional	Optional	-	12	H1, H5, H6, H7
1985-93	1FX324-F1D-I/F1-I/F1A-I	specify	3"	Standard	add'l 12 rib	Race Valve	Optional	Optional	Yes	12	H1, H2, H5, H6, H7
1985-93	1FX022-F1A94/F1C/F1R	specify	-	Standard	add'l 12 rib	Race Valve	Optional	Optional	-	12	H1, H5, H6, H7
1985-93	1FX124-F1A94-I/F1C-I/F1R-I	specify	3.5"	Standard	add'l 12 rib	Race Valve	Optional	Optional	Yes	12	H1, H2, H3, H5, H6, H7

## 1964½-66 MUSTANG AND EARLY FORD (289, 302, 351 V8) SPECIFICATIONS

Year	Part Number	HP Gain	Tube Diam	Carb Hat	Drive System	Bypass Valve	Power Steering Bracket	Alternator Bracket	Tubing Supplied	SC Warranty (in months)	Foot Notes
1964.5-66	1FX400-P1SC	specify	-	Standard	add'l 8 rib	ProFlow	Optional	Optional	-	12	H8, H9, H10
1964.5-66	1FX400-P1SC-I	specify	3"	Standard	add'l 8 rib	ProFlow	Optional	Optional	Yes	12	H8, H9, H10

Call for '69-73 Mustang, '66-73 Fairlane, Maverick, Comet, Falcon, Torino.

## FORD AUTOMOTIVE FOOTNOTES (specific to above applications):

- H1) Carbureted systems require Holley 4150 series or similar blow-through carburetor (sold separately by others) and fuel system upgrade (sold separately by ProCharger and others)
- H2) Specify Universal or Fox Body intercooler kit and tubing
- H3) Universal intercooler tubing kit, not designed for a specific vehicle
- H4) ProCharger pulleys do not line up with factory (OEM) 6-rib accessory pulleys—realignment of factory accessories is required
- H5) Specify engine deck height
- H6) Specify Windsor or Yates cylinder heads
- H7) Specify with or without P/S; does not work with A/C
- H8) Factory balancer required
- H9) Alternator bracket option requires 1986-93 Fox Body alternator
- H10) Power steering pump bracket option requires 1986-93 Fox Body p/s pump



CONTACT US AT (913) 338-2886 OR LEARN MORE AT PROCHARGER.COM

**CARBURETED AND AFTERMARKET EFI FORD SB COG RACE KITS (1985-93 MUSTANG ACCESSORIES)**

Year	Part Number	Description	Boost Options	HP Gain	Intercooler	Price/MAP
1985-93	<b>1FX224-F1D/F1/F1A</b>	Cog Race Kit with F-1D, F-1, F-1A	specify	specify	-	\$6,799
1985-93	1FX234-F1D-I/F1-I/F1A-I	<b>Intercooled Cog Race Kit with F-1D, F-1, or F-1A</b>	specify	specify	Sht mtl 3C (950hp)	\$8,249
1985-93	<b>1FX224-F1C/F1R</b>	Cog Race Kit with F-1C, F-1R	specify	specify	-	\$7,149
1985-93	1FX234-F1C-I/F1R-I	<b>Intercooled Cog Race Kit with F-1C or F-1R</b>	specify	specify	Sht mtl 3C (1050hp)	\$8,549
1985-93	<b>1FX224-F1X</b>	Cog Race Kit with F-1X	specify	specify	-	\$7,699
1985-93	1FX234-F1X-I	<b>Intercooled Cog Race Kit with F-1X</b>	specify	specify	Sht mtl 3C (1300hp)	\$9,299
1985-93	<b>1FX224-F2</b>	Cog Race Kit with F-2	specify	specify	-	\$8,199
1985-93	1FX234-F2-I	<b>Intercooled Cog Race Kit with F-2</b>	specify	specify	Sht mtl 3C (1300hp)	\$9,749
1985-93	<b>1FX224-F3A-spec</b>	Cog Race Kit with F-3R-121	specify	specify	-	\$9,149
1985-93	1FX224-F3R-spec	Cog Race Kit with F-3R-13N (specify 130 or 136)	specify	specify	-	\$9,599
1985-93	<b>1FX223-F1R</b>	Reverse Race Kit with F-1R	specify	specify	-	\$7,649
1985-93	1FX223-F1X	Reverse Race Kit with F-1X	specify	specify	-	\$8,199
1985-93	<b>1FX223-F2R</b>	Reverse Race Kit with F-2	specify	specify	-	\$8,499
1985-93	1FX223-F3RR-spec	Reverse Race Kit with F-3R-121	specify	specify	-	\$10,049
1985-93	<b>1FX223-F3RR-spec</b>	Reverse Race Kit with F-3R-13N (specify 130 or 136)	specify	specify	-	\$10,399

<b>1985-93 CARB &amp; AFTERMARKET EFI FORD SB COG RACE KIT OPTIONS</b>	add "B" or "P" to part #	Black or Polished finish for ProCharger (P-series or D-series )	satin standard	-	-	+\$325
	add "B" or "P" to part #	Black or Polished finish for ProCharger (F-series 9"9.75" housing)	satin standard	-	-	+\$350
	add "B" or "P" to part #	Black or Polished finish for ProCharger (10.5" housing)	satin standard	-	-	+\$375
	add "B" or "P" to part #	Black or Polished finish for ProCharger (12" housing)	satin standard	-	-	+\$425
	add "BB" or "PB" to part #	Black or Polished finish for supercharger bracket	satin standard	-	-	+\$275
	add "BC" or "PC" to part #	Black or Polished finish for carburetor bonnet	satin standard	-	-	+\$100
	add-A91 to part #	With F-1A-91 ProCharger (from F-1D, F-1, F-1A kit)	specify	specify	-	+\$350
	add-A94 to part #	With F-1A-94 ProCharger (from F-1D, F-1, F-1A kit)	specify	specify	-	+\$350
	add "-112" to part #	With F-1X-12/F-3R-112 ProCharger (replacing F-3R-121)	specify	specify	-	-\$300
	3FASS-00X	Race Bypass Valve, Open or Closed (specify alum. or steel flange)	red or black	-	-	included
	add "-PRV" to part #	ProRace Bypass Valve (single)	from race valve	-	-	+\$270
	add "-CV" to part #	Competition Bypass Valve	from race valve	-	-	+\$50
	add "-CV2" to part #	Competition Bypass Valve (pair), red or black	from ProRace	-	-	+\$598
	add "-CB" to part #	Competition carb bonnet upgrade	from std.	-	-	+\$50
	AM001A-001	Competition carburetor bonnet	-	-	-	+\$292
	3FAAT-002	Alternator Relocation Kit	satin finish only	-	-	+\$355
	A1003A-002	Sheet metal 3 core race intercooler (950 hp)	from non-ic kit	3" in/outlet	-	+\$1,398
	A1003A-005	Sheet metal 3 core race intercooler (1050 hp)	from non-ic kit	3.5" in/outlet	-	+\$1,498
	A1045A-001	Sheet metal 3 core race intercooler (1300 hp)	from non-ic kit	3.5" in/outlet	-	+\$1,798
	A1006A-001	Sheet metal 3 core race intercooler (1550 hp)	from non-ic kit	4" in/outlet	-	+\$2,298
W11005A-001	Air/water race intercooler (race use only)	-	1,800 hp max	-	+\$2,498	
W11005A-002	Air/water race intercooler (race use only)	-	2,500+ hp max	-	+\$2,998	
FV0021-BST	Boost sensitive fuel pressure regulator (Carb only, 1000hp capable)	-	-	-	+\$315	
FP0011-006	High Performance 1000 hp electric fuel pump	-	-	-	+\$438	

**FOR COYOTE & GODZILLA TRANSPLANT KITS, SEE PAGE 24**



# SPECIFICATIONS (CARB AND AFTERMARKET EFI SMALL BLOCK)

## CARBURETED, AFTERMARKET EFI FORD SB COG RACE KIT (1985-93 MUSTANG ACCESSORIES) SPECIFICATIONS

Year	Part Number	HP Gain	Tube Diam	Carb Hat	Drive System	Bypass Valve	Alternator Relocation Kit	Alternator with P/S Relocation Kit	Tubing Supplied	SC Warranty (in months)	Foot Notes
1985-93	1FX224-F1D/F1/F1A	specify	-	Standard	8 x 50 mm Cog	Race Valve	Optional	N/A	-	Limited	11, 12, 15, 16
1985-93	1FX234-F1D-I/F1-I/F1A-I	specify	3"	Standard	8 x 50 mm Cog	Race Valve	Optional	N/A	Yes	Limited	11, 12, 13, 15, 16
1985-93	1FX224-F1C/F1R	specify	-	Standard	8 x 50 mm Cog	Race Valve	Optional	N/A	-	Limited	11, 12, 15, 16
1985-93	1FX234-F1C-I/F1R-I	specify	3"	Standard	8 x 50 mm Cog	Race Valve	Optional	N/A	Yes	Limited	11, 12, 14, 15, 16
1985-93	1FX224-F1X	specify	-	Standard	8 x 50 mm Cog	Race Valve	Optional	N/A	-	Limited	11, 12, 15, 16
1985-93	1FX234-F1X-I	specify	3"	Standard	8 x 50 mm Cog	Race Valve	Optional	N/A	Yes	Limited	11, 12, 14, 15, 16
1985-93	1FX224-F2	specify	-	Standard	8 x 50 mm Cog	Race Valve	Optional	N/A	-	Limited	11, 12, 15, 16, 17
1985-93	1FX234-F2-I	specify	3.5"	Standard	8 x 50 mm Cog	Race Valve	Optional	N/A	Yes	Limited	11, 12, 14, 15, 16
1985-93	1FX224-F3A-spec	specify	-	-	14 x 55 mm Cog	ProRace Valve	Optional	N/A	-	Limited	11, 12, 15, 16
1985-93	1FX224-F3R-spec	specify	-	-	14 x 55 mm Cog	ProRace Valve	Optional	N/A	-	Limited	11, 12, 15, 16, 17
1985-93	1FX223-F1R	specify	-	-	8 x 75 mm Cog	Race Valve	N/A	N/A	-	Limited	11, 15, 16
1985-93	1FX223-F1X	specify	-	-	8 x 75 mm Cog	Race Valve	N/A	N/A	-	Limited	11, 15, 16
1985-93	1FX223-F2R	specify	-	-	8 x 75 mm Cog	Race Valve	N/A	N/A	-	Limited	11, 15, 16
1985-93	1FX223-F3RR-spec	specify	-	-	8 x 75 mm Cog	ProRace Valve	N/A	N/A	-	Limited	11, 15, 16
1985-93	1FX223-F3RR-spec	specify	-	-	8 x 75 mm Cog	ProRace Valve	N/A	N/A	-	Limited	11, 15, 16

### FORD AUTOMOTIVE FOOTNOTES (specific to above applications):

- 1) Carbureted systems require Holley 4150 series or similar blow-through carburetor (sold separately by others) and fuel system upgrade (sold separately by ProCharger and others)
- 2) Specify universal or Fox Body intercooler kit tubing
- 3) Universal intercooler tubing kit, not designed for a specific vehicle
- 4) ProCharger pulleys do not line up with factory (OEM) 6-rib accessory pulleys—realignment of factory accessories is required
- 5) Specify engine deck height
- 6) Specify Windsor or Yates cylinder heads
- 7) Special order kit: order form and non-refundable deposit required at time of order—may require additional lead time for processing



CONTACT US AT (913) 338-2886 OR LEARN MORE AT PROCHARGER.COM

## COYOTE ENGINE SWAP (5.0 4V) SERPENTINE KITS - REVERSE MOUNT

Year	Part Number	Description	Boost Options	HP Gain	Intercooler	Price/MAP
specify	1FA500-P1SC1-I	High Output Intercooled Tuner Kit with P-1SC-1	specify	specify	Stage II	\$7,099
specify	1FA500-P1SC1	High Output Tuner Kit with P-1SC-1	specify	specify	-	\$5,799
specify	1FA500-F1-I	High Output Intercooled Kit with F-1D, F-1 or F-1A	specify	specify	Air-to-Air Race	\$8,699
specify	1FA500-F1	High Output Kit with F-1D, F-1, or F-1A	specify	specify	-	\$7,399
specify	1FA500-F1C-I/F1R-I	High Output Intercooled Kit with F-1A-94, F-1C or F-1R	specify	specify	Air-to-Air Race	\$9,049
specify	1FA500-F1C/F1R	High Output Kit with F-1A-94, F-1C or F-1R	specify	specify	-	\$7,749

## COYOTE ENGINE SWAP (5.0 4V) SERPENTINE & COG KITS - STANDARD MOUNT

Year	Part Number	Description	Boost Options	HP Gain	Intercooler	Price/MAP
specify	1FA300-P1SC1-I	High Output Intercooled Tuner Kit with P-1SC-1	specify	specify	Stage II	\$7,099
specify	1FA300-P1SC1	High Output Tuner Kit with P-1SC-1	specify	specify	-	\$5,799
specify	1FA300-F1-I	High Output Intercooled Kit with F-1D, F-1 or F-1A	specify	specify	Air-to-Air Race	\$8,699
specify	1FA300-F1	High Output Kit with F-1D, F-1, or F-1A	specify	specify	-	\$7,149
specify	1FA300-F1C-I/F1R-I	High Output Intercooled Kit with F-1A-94, F-1C or F-1R	specify	specify	Air-to-Air Race	\$9,049
specify	1FA300-F1C/F1R	High Output Kit with F-1A-94, F-1C or F-1R	specify	specify	-	\$7,449
specify	1FA400-F1-I	Intercooled Cog Race Kit with F-1D, F-1 or F-1A	specify	specify	Air-to-Air Race	\$8,749
specify	1FA400-F1	Cog Race Kit with F-1D, F-1, or F-1A	specify	specify	-	\$7,149
specify	1FA400-F1C-I/F1R-I	Intercooled Cog Race Kit with F-1A-94, F-1C or F-1R	specify	specify	Air-to-Air Race	\$9,049
specify	1FA400-F1C/F1R	Cog Race Kit with F-1A-94, F-1C or F-1R	specify	specify	-	\$7,449

## COYOTE ENGINE SWAP 92-96 F-150/LIGHTNING/BRONCO (5.0 4V) KITS

Year	Part Number	Description	Boost Options	HP Gain	Intercooler	Price/MAP
specify	1FA700-P1SC1-I	High Output Intercooled Tuner Kit with P-1SC-1	specify	specify	Stage II	\$7,099

## GODZILLA ENGINE SWAP (7.3) KITS

Year	Part Number	Description	Boost Options	HP Gain	Intercooler	Price/MAP
specify	1FA600-P1SC1-I	High Output Intercooled Tuner Kit with P-1SC-1	specify	specify	Stage II	\$7,099
specify	1FA600-P1SC1	High Output Tuner Kit with P-1SC-1	specify	specify	-	\$5,799

<b>(5.0, 7.3) ENGINE SWAP OPTIONS</b>	add "-B" or "-P" to part #	Black or Polished finish for ProCharger (P-series or D-series)	satin standard	-	-	+\$325
	add "-B" or "-P" to part #	Black or Polished finish for ProCharger (F-series, 9" or 9.75" housing)	satin standard	-	-	+\$350
	add "-B" or "-P" to part #	Black or Polished finish for ProCharger (F-series, 10.5" housing)	satin standard	-	-	+\$375
	add "-BB" or "-PB" to part #	Black or Polished finish for supercharger bracket	satin standard	-	-	+\$275
	add "-H" to part #	Helical gearset for noise reduction (P-1SC-1, P-1X, D-1SC, D-1X)	same	same	-	+\$110
	add "-P1X" to part #	With P-1X ProCharger (replacing P-1SC-1)	same	add'l 10-15+ hp	-	+\$250
	add "-D1SC" to part #	With D-1SC ProCharger (replacing P-1SC-1)	tuner kit only	specify	-	+\$275
	add "-D1X" to part #	With D-1X ProCharger (replacing P-1SC-1)	tuner kit only	specify	-	+\$475
	add "-D" or "-1" or "-A"	With F-1D, F-1, F-1A ProCharger (replacing P-1SC-1)	tuner kit only	specify	-	+\$875
	add "-94" or "C" or "R"	With F-1A-94, F-1C or F-1R ProCharger (replacing P-1SC-1)	tuner kit only	-	-	+\$1,225
	add "-F1X" to part #	With F-1X ProCharger (replacing P-1SC-1), except Gen 1	tuner kit only	-	-	+\$2,490
	add "-10R" to part #	10 rib drive system upgrade (HO Tuner Kits only)	from 8 rib	-	-	+\$360
	add "-RVR" or "RVB"	Race Bypass Valve Upgrade (specify open or closed valve; red or black)	from ProFlow	specify	-	+\$295
	add "-Race" to part #	Air-to-Air Race intercooler upgrade	from Stage II	1000 hp max	3" Tubing	+\$435
	<b>(5.0 Only) OPTIONS</b>	AI003A-001	3 core intercooler (825 hp)	from non-ic kit	3" in/outlet	-
AI003A-002		Sheet metal 3 core race intercooler (950 hp)	from non-ic kit	3" in/outlet	-	+\$1,398
AI003A-005		Sheet metal 3 core race intercooler (1050 hp)	from non-ic kit	3.5" in/outlet	-	+\$1,498
AI045A-001		Sheet metal 3 core race intercooler (1300 hp)	from non-ic kit	3.5" in/outlet	-	+\$1,798
AI006A-001		Sheet metal 3 core race intercooler (1550 hp)	from non-ic kit	4" in/outlet	-	+\$2,298
add "-CS" to part #		Coyote Crank Support (serpentine only)	satin standard	-	-	+\$675
add "-BC" or "-PC" to part #		Black or Polished finish for Crank Support	satin standard	-	-	+\$275
	add "-CT" to part #	Coolant Tank Reservoir Replacement Kit	-	-	-	+\$298

# SPECIFICATIONS (COYOTE & GODZILLA ENGINE SWAP KITS)

## COYOTE ENGINE SWAP (5.0 4V) SERPENTINE KITS - REVERSE MOUNT SPECIFICATIONS

Year	Part Number	OEM hp Rating	HP Gain	Tube Diam	Drive System	Bypass Valve	Fuel System Upgrade	Fuel Inj. Supplied	Computer/Ignition Modifications	SC Warranty (in months)	CARB E.O.	Foot Notes
specify	1FA500-P1SC1-I	N/A	specify	3"	add'l 8 rib	ProFlow	not supplied	No	not supplied	12	-	J2, J3, J5, J6, J8
specify	1FA500-P1SC1	N/A	specify	-	add'l 8 rib	ProFlow	not supplied	No	not supplied	12	-	J2, J3, J5, J6, J8
specify	1FA500-F1-I	N/A	specify	3"	add'l 8 rib	Race	not supplied	No	not supplied	Limited	-	J1, J2, J3, J5, J6, J8
specify	1FA500-F1	N/A	specify	-	add'l 8 rib	Race	not supplied	No	not supplied	Limited	-	J1, J2, J3, J5, J6, J8
specify	1FA500-F1C-I/F1R-I	N/A	specify	3"	add'l 8 rib	Race	not supplied	No	not supplied	Limited	-	J1, J2, J3, J5, J6, J8
specify	1FA500-F1C/F1R	N/A	specify	-	add'l 8 rib	Race	not supplied	No	not supplied	Limited	-	J1, J2, J3, J5, J6, J8

## COYOTE ENGINE SWAP (5.0 4V) SERPENTINE & COG KITS - STANDARD MOUNT SPECIFICATIONS

Year	Part Number	OEM hp Rating	HP Gain	Tube Diam	Drive System	Bypass Valve	Fuel System Upgrade	Fuel Inj. Supplied	Computer/Ignition Modifications	SC Warranty (in months)	CARB E.O.	Foot Notes
specify	1FA400-P1SC1-I	N/A	specify	3"	add'l 8 rib	ProFlow	not supplied	No	not supplied	12	-	J2, J3, J4, J8
specify	1FA400-P1SC1	N/A	specify	-	add'l 8 rib	ProFlow	not supplied	No	not supplied	12	-	J2, J3, J4, J8
specify	1FA400-F1-I	N/A	specify	3"	add'l 8 rib	Race	not supplied	No	not supplied	Limited	-	J1, J2, J3, J4, J8
specify	1FA400-F1	N/A	specify	-	add'l 8 rib	Race	not supplied	No	not supplied	Limited	-	J1, J2, J3, J4, J8
specify	1FA400-F1C-I/F1R-I	N/A	specify	3"	add'l 8 rib	Race	not supplied	No	not supplied	Limited	-	J1, J2, J3, J4, J8
specify	1FA400-F1C/F1R	N/A	specify	-	add'l 8 rib	Race	not supplied	No	not supplied	Limited	-	J1, J2, J3, J4, J8
specify	1FA300-F1-I	N/A	specify	3"	cog	Race	not supplied	No	not supplied	Limited	-	J1, J2, J3, J4, J8
specify	1FA300-F1	N/A	specify	-	cog	Race	not supplied	No	not supplied	Limited	-	J1, J2, J3, J4, J8
specify	1FA300-F1C-I/F1R-I	N/A	specify	3"	cog	Race	not supplied	No	not supplied	Limited	-	J1, J2, J3, J4, J8
specify	1FA300-F1C/F1R	N/A	specify	-	cog	Race	not supplied	No	not supplied	Limited	-	J1, J2, J3, J4, J8

## COYOTE ENGINE SWAP 92-96 F-150/LIGHTNING/BRONCO (5.0 4V) SPECIFICATIONS

Year	Part Number	OEM hp Rating	HP Gain	Tube Diam	Drive System	Bypass Valve	Fuel System Upgrade	Fuel Inj. Supplied	Computer/Ignition Modifications	SC Warranty (in months)	CARB E.O.	Foot Notes
specify	1FA700-P1SC1-I	N/A	specify	3"	add'l 8 rib	ProFlow	not supplied	No	not supplied	12	-	J2, J3, J5, J6, J8

## GODZILLA ENGINE SWAP (7.3) SPECIFICATIONS

Year	Part Number	OEM hp Rating	HP Gain	Tube Diam	Drive System	Bypass Valve	Fuel System Upgrade	Fuel Inj. Supplied	Computer/Ignition Modifications	SC Warranty (in months)	CARB E.O.	Foot Notes
specify	1FA600-P1SC1-I	N/A	specify	3"	add'l 8 rib	ProFlow	not supplied	No	not supplied	12	-	J2, J7, J8
specify	1FA600-P1SC1	N/A	specify	-	add'l 8 rib	ProFlow	not supplied	No	not supplied	12	-	J2, J7, J8

## FORD AUTOMOTIVE FOOTNOTES (specific to above applications):

- J1) Modified engines only
- J2) System ships in extra large box
- J3) Specify factory or aftermarket balancer
- J4) Requires 2011-14 Mustang accessories and utilizes 2011-14 Mustang intercooler and tubing
- J5) Reverse mount Coyote swap kits require car Gt timing cover
- J6) Requires 2015+ Mustang accessories and utilizes 2015+ Mustang intercooler and tubing
- J7) Requires Innovators West balancer #IW807
- J8) Requires engine model year
- J9) Custom crank support recommended for cog kit (sold separately by others)



**2020-23 CORVETTE C8 COUPE (LT2) SYSTEMS AND KITS**

Year	Part Number	Description	Boost Options	HP Gain	Intercooler	Price
2020-23	1KC312-SCI	High Output Intercooled Sytem with P-1SC-1 (satin finish)	5 psi	170 hp	Air-to-Water	\$19,999
2020-23	1KC412-SCI	Stage II Intercooled System with P-1SC-1 (satin finish)	7.5 psi	45%+	Air-to-Water	\$20,399
2020-23	1KC402-SCI	Stage II Intercooled Tuner Kit (w/ port injection manifold) with P-1SC-1 (satin finish)	specify	specify	Air-to-Water	\$16,999

**\*NEW\* 2020-23 CORVETTE C8 CONVERTIBLE (LT2) SYSTEMS AND KITS**

Year	Part Number	Description	Boost Options	HP Gain	Intercooler	Price/MAP
2020-23	1KC512-SCI	High Output Intercooled Sytem with P-1SC-1 (satin finish)	5 psi	170 hp	Air-to-Water	\$21,299
2020-23	1KC612-SCI	Stage II Intercooled System with P-1SC-1 (satin finish)	7.5 psi	45%+	Air-to-Water	\$21,699
2020-23	1KC602-SCI	Stage II Intercooled Tuner Kit with P-1SC-1 (satin finish)	specify	specify	Air-to-Water	\$18,299

<b>2020-23 C8 CORVETTE (LT2) OPTIONS</b>	add "-B" or "-P" to part #	Black or Polished Finish for supercharger (P-series or D-series)	satin standard	-	-	+\$325
	add "-B" or "-P" to part #	Black or Polished finish for supercharger bracket (satin finish standard)	satin standard	-	-	+\$275
	add "-BI" to part #	Black Finish for Intake Manifold (raw finish standard)	unfinished std	-	-	+\$350
	add "-BC" to part #	Black Finish for Intake Manifold Cover (raw finish standard)	unfinished std	-	-	+\$50
	add "-H" to part #	Helical gearsset for noise reduction (P-1SC-1, P-1X, D-1SC, D-1X)	same	same	-	+\$110
	add "-P1X" to part #	With P-1X ProCharger (replacing P-1SC-1, additional 10-15+ hp)	same	add'l 10-15+ hp	-	+\$250
	add "-D1SC" to part #	With D-1SC ProCharger (replacing P-1SC-1, Stage II only)	tuner kit only	specify	-	+\$275
	add "-D1X" to part #	With D-1X ProCharger (replacing P-1SC-1, Stage II only)	tuner kit only	specify	-	+\$475
	add "-CF" to part #	With carbon fiber intake manifold cover - Special Order	-	-	-	+\$1,399
	add "-CT" to part #	With carbon fiber trunk cover - Special Order	-	-	-	+\$1799
-omit	Omit port injector bungs and fuel rails	coupe tuner kit only	-	-	-\$500	

\* Some options may not be available for HTC; call for details

**CALL FOR Z06 & E-RAY INFORMATION**



# SPECIFICATIONS (C8 CORVETTE COUPE & CONVERTIBLE)

## 2020-23 CORVETTE C8 COUPE (LT2) SPECIFICATIONS

Year	Part Number	OEM hp Rating	HP Gain	Tube Diam	IC Mount	Drive System	Bypass System	Fuel System Upgrade	Fuel Inj. Supplied	Computer/Ignition Modifications	SC Warranty (in months)	CARB E.O.	Foot Notes
2020-23	1KC312-SCI	495	170 hp	3.5"	AW	stk 6 rib	not req'd	not required	no	timing control supplied	12, 36 opt. (\$99)	-	KK: 1,3,4,5,6,7,11,13,14
2020-23	1KC412-SCI	495	45%+	3.5"	AW	stk 6 rib	not req'd	not supplied	no	not supplied	12	-	KK: 1,3,4,5,6,7,11,13,14
2020-23	1KC402-SCI	495	specify	3.5"	AW	stk 6 rib	not req'd	not required	no	timing control supplied	12, 36 opt. (\$99)	-	KK: 1,2,3,4,5,6,7,9,10,12

## \*NEW\* 2020-23 CORVETTE C8 CONVERTIBLE (LT2) SPECIFICATIONS

Year	Part Number	OEM hp Rating	HP Gain	Tube Diam	IC Mount	Drive System	Bypass System	Fuel System Upgrade	Fuel Inj. Supplied	Computer/Ignition Modifications	SC Warranty (in months)	CARB E.O.	Foot Notes
2020-23	1KC512-SCI	495	170 hp	3.5"	AW	stk 6 rib	not req'd	not required	no	timing control supplied	12, 36 opt. (\$99)	-	KK: 3,4,5,6,7,11,13,14
2020-23	1KC612-SCI	495	45%+	3.5"	AW	stk 6 rib	not req'd	not supplied	no	not supplied	12	-	KK: 3,4,5,6,7,11,13,14
2020-23	1KC602-SCI	495	specify	3.5"	AW	stk 6 rib	not req'd	not required	no	timing control supplied	12, 36 opt. (\$99)	-	KK: 2,3,4,5,6,7,9,10,12

### CHEVROLET AUTOMOTIVE FOOTNOTES (specific to above applications):

- KK1) Does not fit convertible
- KK2) Dyno tuning is required
- KK3) Clutch upgrade and/or controller may be required
- KK4) Multi-part shipment, additional shipping charges apply
- KK5) Model year, Base or Z51, and VIN # must be specified
- KK6) Carbon fiber trunk cover and manifold cover requires special order
- KK7) No cutting required, trunk carpet trimming recommended
- KK9) Port Injection Option requires LS3/60mm full length injectors, no fuel injector hats
- KK10) For race use only
- KK11) Includes all hardware for a stock engine, stock exhaust car only
- KK12) Stage II Tuner kit does not include necessary fuel system or timing components
- KK13) PCM removal and shipment required
- KK14) Specify base model or Z51 package



**2014-19 CORVETTE C7 STINGRAY (LT1) AND 2017-18 GRAND SPORT (LT1) SYSTEMS AND KITS**

Year	Part Number	Description	Boost Options	HP Gain	Intercooler	Price/MAP
2014-19	1GU212-SCI	High Output Intercooled System with P-1SC-1 (satin finish)	7 psi	40%+	Vertical	\$7,199
2014-19	1GU202-SCI	High Output Intercooled Tuner Kit with P-1SC-1 (satin finish)	specify	specify	Vertical	\$6,899
2014-19	1GU402-F1	Competition Race Tuner Kit with F-1D, F-1 or F-1A (satin finish)	specify	specify	1250+ hp AW	\$11,299
2014-19	1GU402-94	Competition Race Tuner Kit with F-1A-94, F-1C or F-1R (satin finish)	specify	specify	1250+ hp AW	\$11,649
2014-19	1GU502-F1	Pro Race Tuner Kit with F-1D, F-1 or F-1A (satin finish)	specify	specify	1500+ hp AW	\$12,499
2014-19	1GU502-94	Pro Race Tuner Kit with F-1A-94, F-1C or F-1R (satin finish)	specify	specify	1500+ hp AW	\$12,849

**2015-19 CORVETTE C7 Z06 (LT4) KITS**

Year	Part Number	Description	Boost Options	HP Gain	Intercooler	Price/MAP
2015-19	1GU204-SCI	High Output Intercooled Tuner Kit with D-1SC (satin finish)	specify	specify	Vertical	\$9,599
2015-19	1GU204-SCI-F1	Intercooled Race Tuner Kit with F-1D, F-1, F-1A (satin finish)	specify	specify	Vertical	\$10,399
2015-19	1GU204-SCI-94	Intercooled Race Tuner Kit with F-1A-94, F-1C, or F-1R (satin finish)	specify	specify	Vertical	\$10,749
2015-19	1GU300-F1	Competition Race Tuner Kit with F-1D, F-1, F-1A (satin finish)	specify	specify	1250+ hp AW	\$12,399
2015-19	1GU300-94	Competition Race Tuner Kit with F-1A-94, F-1C, or F-1R (satin finish)	specify	specify	1250+ hp AW	\$12,749
2015-19	1GU500-F1	Pro Race Tuner Kit with F-1D, F-1 or F-1A (satin finish)	specify	specify	1500+ hp AW	\$13,499
2015-19	1GU500-94	Pro Race Tuner Kit with F-1A-94, F-1C or F-1R (satin finish)	specify	specify	1500+ hp AW	\$13,849

<b>2014-19 C7 CORVETTE (LT1 AND LT4) OPTIONS</b>	add "-B" or "-P" to part #	Black or Polished Finish for supercharger/bracket (P-series or D-series)	satin standard	-	-	+\$595
	add "-B" or "-P" to part #	Black or Polished Finish for supercharger/bracket (F-series, 9" or 9.75" housing)	satin standard	-	-	+\$625
	add "-B" or "-P" to part #	Black or Polished finish for supercharger/bracket (F-series, 10.5" housing)	satin standard	-	-	+\$695
	add "-BI" to part #	Black Finish for Intake Manifold (unfinished standard)	unfinished std	-	-	+\$225
	add "-BC" to part #	Black Finish for Intake Manifold Cover (unfinished standard)	unfinished std	-	-	+\$35
	add "-H" to part #	Helical gerset for noise reduction (P-1SC-1, P-1X, D-1SC, D-1X)	same	same	-	+\$110
	Add "-10R" to part #	10 Rib Belt Drive Upgrade	tuner kit only	-	-	+\$360
	add "-CP" to part #	8.80" Crank Pulley Upgrade (10 rib only)	-	-	-	+\$120
<b>2014-19 C7 CORVETTE (LT1 ONLY) OPTIONS</b>	add "-AB" to part #	Factory Air Box Inlet and Filter (Race Air Inlet and Filter standard)	7 psi max	same	-	+\$215
	add "-P1X" to part #	With P-1X ProCharger (replacing P-1SC-1, Systems and Tuner Kits)	same	add'l 10-15+ hp	-	+\$250
	add "-D1SC" to part #	With D-1SC ProCharger (replacing P-1SC-1)	tuner kit only	specify	-	+\$275
	add "-D1X" to part #	With D-1X ProCharger (replacing P-1SC-1, Tuner Kits only)	tuner kit only	specify	-	+\$475
	add "-D" or "-1" or "-A"	With F-1D, F-1, F-1A ProCharger (replacing P-1SC-1)	tuner kit only	specify	-	+\$875
	add "-94" or "-C" or "-R"	With F-1A-94, F-1C or F-1R ProCharger (replacing P-1SC-1)	tuner kit only	-	-	+\$1,225
	add "-F1X" to part #	With F-1X ProCharger (replacing P-1SC-1)	tuner kit only	-	-	+\$2,490
	add "-F1X" to part #	With F-1X ProCharger and Bellmouth (replacing F-1A-94, F-1C or F-1R)	tuner kit only	specify	-	+\$1,265
	add "-BV" to part #	Bullet Bypass Valve Upgrade	-	-	-	+\$125
	add "-RVR" or "-RVB"	Race Bypass Valve Upgrade (open only)	red or black	specify	-	+\$295
	3FASS-00X	Additional Race Bypass Valve (open only, specify alum. or steel flange, Race Kit only)	red or black	-	-	+\$498
	add "-ATIPP" to part #	ATI Performance Products Balancer Upgrade	-	-	-	+\$525
<b>2015-19 C7 CORVETTE Z06 (LT4 ONLY)</b>	add "-INT" to part #	Sheet Metal Aluminum Intake Manifold and Cover (Tuner Kit Only)	unfinished std	-	-	+\$2,498
	add "-INT/INJ" to part #	Sheet Metal Aluminum Intake Manifold and Cover w/ injector bungs and fuel rails	tuner kit only	-	-	+\$2,998
	add "-D1X" to part #	With D-1X ProCharger (replacing D-1SC)	tuner kit only	specify	-	+\$200
	add "-F1X" to part #	With F-1X ProCharger and Bellmouth (replacing F-1A-94, F-1C or F-1R)	specify	specify	-	+\$1,265
	add "-RVR" or "-RVB"	Race Bypass Valve Upgrade (open only, from Bullet)	red or black	specify	-	+\$295
	add "-INT/INJ" to part #	Sheet Metal Aluminum Intake Manifold w/ injector bungs and fuel rails (Tuner Kit Only)	unfinished std	-	-	+\$500

**2014-17 CORVETTE C7 STINGRAY (LT1) i-1 PROGRAMMABLE RATIO SYSTEMS**

Year	Part Number	Description	Boost Options	HP Gain	Intercooler	Price/MAP
2014-17	1GU312-SCI	High Output Intercooled Systems with i-1	7 psi	45%+	Vertical	\$10,499

**SEE PAGE 30 FOR i-1 OPTIONS**

# SPECIFICATIONS (C7 CORVETTE)

## 2014-19 CORVETTE C7 STINGRAY (LT1) AND 2017-18 GRAND SPORT (LT1) SPECIFICATIONS

Year	Part Number	OEM hp Rating	HP Gain	Tube Diam	IC Mount	Drive System	Bypass System	Fuel System Upgrade	Fuel Inj. Supplied	Computer/Ignition Modifications	SC Warranty (in months)	CARB E.O.	Foot Notes
2014-19	1GU212-SCI	455	40%+	3"	V	add'l 8 rib	ProFlow	not required	not required	programmer supplied	12, 36 opt. (\$99)	D-365-17	K: 1, 2, 3, 5, 6, 7, 8, 10
2014-19	1GU202-SCI	455	specify	3"	V	add'l 8 rib	ProFlow	not supplied	no	not supplied	12	-	K: 1, 2, 3, 5, 6, 7, 8, 9, 10, 11, 13
2014-19	1GU402-F1	455	specify	3"	V	add'l 8 rib	Race	not supplied	no	not supplied	12	-	K: 1, 2, 3, 5, 6, 7, 8, 9, 10, 11, 13
2014-19	1GU402-94	455	specify	3"	V	add'l 8 rib	Race	not supplied	no	not supplied	12	-	K: 1, 2, 3, 5, 6, 7, 8, 9, 10, 11, 13
2014-19	1GU502-F1	455	specify	3"	V	add'l 8 rib	Race	not supplied	no	not supplied	12	-	K: 1, 2, 3, 5, 6, 7, 8, 9, 10, 11, 12, 13
2014-19	1GU502-94	455	specify	3"	V	add'l 8 rib	Race	not supplied	no	not supplied	12	-	K: 1, 2, 3, 5, 6, 7, 8, 9, 10, 11, 12, 13

## 2015-19 CORVETTE C7 Z06 (LT4) SPECIFICATIONS

Year	Part Number	OEM hp Rating	HP Gain	Tube Diam	IC Mount	Drive System	Bypass System	Fuel System Upgrade	Fuel Inj. Supplied	Computer/Ignition Modifications	SC Warranty (in months)	CARB E.O.	Foot Notes
2015-19	1GU204-SCI	650	specify	3"	V	add'l 8 rib	Bullet	not required	not required	not supplied	12	-	K: 1, 2, 5, 6, 10, 11, 13
2015-19	1GU204-SCI-F1	650	specify	3"	V	add'l 8 rib	Race	not supplied	no	not supplied	12	-	K: 1, 2, 5, 6, 10, 11, 13
2015-19	1GU204-SCI-94	650	specify	3"	V	add'l 8 rib	Race	not supplied	no	not supplied	12	-	K: 1, 2, 5, 6, 9, 10, 11, 13
2015-19	1GU300-F1	650	specify	3"	A/W	add'l 8 rib	Race	not supplied	no	not supplied	12	-	1, 2, 5, 6, 10, 11, 13
2015-19	1GU300-94	650	specify	3"	A/W	add'l 8 rib	Race	not supplied	no	not supplied	12	-	K: 1, 2, 5, 6, 10, 11, 12, 13
2015-19	1GU500-F1	650	specify	3"	A/W	add'l 8 rib	Race	not supplied	no	not supplied	12	-	K: 1, 2, 5, 6, 10, 11, 12, 13
2015-19	1GU500-94	650	specify	3"	A/W	add'l 8 rib	Race	not supplied	no	not supplied	12	-	K: 1, 2, 5, 6, 9, 10, 11, 12, 13

## 2014-17 CORVETTE C7 STINGRAY (LT1) i-1 SPECIFICATIONS

Year	Part Number	OEM hp Rating	HP Gain	Tube Diam	IC Mount	Drive System	Bypass System	Fuel System Upgrade	Fuel Inj. Supplied	Computer/Ignition Modifications	SC Warranty (in months)	CARB E.O.	Foot Notes
2014-17	1GU312-SCI	455	45%+	3"	V	add'l 8 rib	ProFlow	not required	not required	programmer supplied	12, 36 opt. (\$149)	-	K: 1, 2, 3, 4, 5, 7, 8, 10, 14

## CHEVROLET AUTOMOTIVE FOOTNOTES (specific to above applications):

- K1) Model year and manual or automatic transmission must be specified
- K2) Satin finish is now standard for Corvette systems; polished finish and black finish is optional
- K3) Specify wet or dry oil sump
- K4) Due to variability among OEM computers, the prevalence of custom modifications, and age/miles/condition of vehicles, dyno tuning may be required
- K5) System ships in extra large box
- K6) Specify stock or aftermarket balancer (AT1 Balancer Part Numbers: LT1 Dry #917315, LT1 Wet #917314, Z06 LT4 #917315; specify hardend hub)
- K7) Vertical intercooler recommended for drag racing use
- K8) Horizontal intercooler only available for 2014 Corvette C7's (LT1)
- K9) F-1X supercharger upgrade requires modifications
- K10) Two-part shipment, additional shipping charges may apply
- K11) Works with maximum of 10% overdrive crank pulley
- K12) Ice-tank mount welding, wiring, sway bar removal, vehicle trimming and modifications required
- K13) Port injection Option requires LS3/38mm length injectors
- K14) Special order kit: order form and non-refundable deposit required at time of order—may require additional lead time for processing



## 2008-13 CORVETTE C6 (LS3) SYSTEMS AND KITS

Year	Part Number	Description	Boost Options	HP Gain	Intercooler	Price/MAP
2008-13 (LS3)	1GQ212-SCI	High Output Intercooled System with P-1SC-1 (satin finish)	7 psi	45-50%+	C6 3 Core	\$7,999
2008-13 (LS3)	1GQ202-SCI	High Output Intercooled Tuner Kit with P-1SC-1 (satin finish)	specify	specify	C6 3 Core	\$7,099
2008-13 (LS3)	1GQ314-SCI	Stage II Intercooled System with P-1SC-1 (satin finish)	7 psi	45-50%+	C6 3 core	\$8,649
2008-13 (LS3)	1GQ304-SCI	Stage II Intercooled Tuner Kit with P-1SC-1 (satin finish)	specify	specify	C6 3 core	\$7,849
2008-13 (LS3)	1GQ402-SCI	Intercooled Race Kit with F-1D, F-1 or F-1A (satin finish)	specify	specify	Race	\$9,199
2008-13 (LS3)	1GQ402-SCI-94	Intercooled Race Kit with F-1A-94, F-1C or F-1R (satin finish)	specify	specify	Race	\$9,549

## 2006-13 CORVETTE C6 Z06 (LS7) SYSTEMS AND KITS

Year	Part Number	Description	Boost Options	HP Gain	Intercooler	Price/MAP
2006-13 (LS7)	1GP214-SCI	High Output Intercooled System with P-1SC-1 (satin finish)	4.5 psi	40%+	C6 3 core	\$8,099
2006-13 (LS7)	1GP204-SCI	High Output Intercooled Tuner Kit with P-1SC-1 (satin finish)	specify	specify	C6 3 core	\$7,199
2006-13 (LS7)	1GP314-SCI	Stage II Intercooled System with P-1SC-1 (satin finish)	4.5 psi	40%+	C6 3 core	\$8,899
2006-13 (LS7)	1GP304-SCI	Stage II Intercooled Tuner Kit with P-1SC-1 (satin finish)	specify	specify	C6 3 core	\$8,049
2006-13 (LS7)	1GP404-SCI	Intercooled Race Kit with F-1D, F-1 or F-1A (satin finish)	specify	specify	Race	\$9,399
2006-13 (LS7)	1GP404-SCI-94	Intercooled Race Kit with F-1A-94, F-1C or F-1R (satin finish)	specify	specify	Race	\$9,749

## 2005-07 CORVETTE C6 (LS2) SYSTEMS AND KITS

Year	Part Number	Description	Boost Options	HP Gain	Intercooler	Price/MAP
2005-07	1GP202-SCI	High Output Intercooled System with P-1SC-1 (satin finish)	6 psi	50%+	C6 3 core	\$7,999
2005-07	1GP212-SCI	High Output Intercooled Tuner Kit with P-1SC-1 (satin finish)	specify	specify	C6 3 core	\$7,099
2005-07	1GP315-SCI	Stage II Intercooled System with P-1SC-1 (satin finish)	6 psi	50%+	C6 3 core	\$8,649
2005-07	1GP305-SCI	Stage II Intercooled Tuner Kit with P-1SC-1 (satin finish)	specify	specify	C6 3 core	\$7,849
2005-07	1GP402-SCI	Intercooled Race Kit with F-1D, F-1 or F-1A (satin finish)	specify	specify	Race	\$9,199
2005-07	1GP402-SCI-94	Intercooled Race Kit with F-1A-94, F-1C or F-1R (satin finish)	specify	specify	Race	\$9,549

2005-13 CORVETTE C6 (LS2, LS3, LS7) OPTIONS	add "-B" or "-P" to part #	Black or Polished Finish for supercharger and bracket (P or D-series)	satin standard	-	-	+\$595
	add "-H" to part #	Helical gearset for noise reduction (P-1SC-1, P-1X, D-1SC, D-1X)	same	same	-	+\$110
	add "-P1X" to part #	With P-1X ProCharger (replacing P-1SC-1, Systems and Tuner Kits, non-EO)	same	add'l 10-15+ hp	-	+\$250
	add "-D1SC" to part #	With D-1SC ProCharger (replacing P-1SC-1)	tuner kit only	specify	-	+\$275
	add "-D1X" to part #	With D-1X ProCharger (replacing P-1SC-1, Tuner Kits only)	tuner kit only	specify	-	+\$475
	add "-D" or "-1" or "-A"	With F-1D, F-1, F-1A (replacing P-1SC-1, Stage II only, 8 rib required)	tuner kit only	specify	-	+\$875
	add "-C" or "R" to part #	With F-1C, F-1R, F1A-94 (replacing P-1SC-1, Stage II only, 8 rib required)	tuner kit only	specify	-	+\$1,225
	add "-F1X" to part #	With F-1X ProCharger (replacing F-1C/F-1R, Race kit only)	tuner kit only	specify	-	+\$1,265
	add "-8R" to part #	8 or 10 rib dedicated drive upgrade (Stage II, time of purchase, see footnotes)	from 6 rib	specify	-	+\$360
	add "-WP" to part #	With Modified Water Pump for LS3/LS7	-	-	-	+\$165
add "-Race" to part #	Air-to-Air Race Intercooler Upgrade (HO, Stage II only)	from 3 core	1300 hp max	-	+\$435	
add "-RVR" or "RVB"	Race Bypass Valve Upgrade (HO, Stage II only, included in Race Kits)	red or black	specify	-	+\$295	

## 2008-13 CORVETTE C6 (LS3) i-1 PROGRAMMABLE RATIO SYSTEMS

Year	Part Number	Description	Boost Options	HP Gain	Std Intercooler	Price/MAP
2008-13 (LS3)	1GQ312-SCI	High Output Intercooled System with i-1 (satin finish)	7 psi	50%+	C6 3 core	\$10,399

i-1 OPTIONS	add "-T" to part #	Touchscreen (at time of system purchase)	-	-	-	+\$395
	add "-B" to part #	Black finish for supercharger and bracket	satin standard	-	-	+\$795
	add "-P" to part #	Polished finish for supercharger and bracket (satin finish standard)	satin standard	-	-	+\$595
	add "-R" to part #	Air-to-Air Race Intercooler Upgrade	from C6 3 core	-	-	+\$435



# SPECIFICATIONS (C6 CORVETTE)

## 2008-13 CORVETTE C6 (LS3) SPECIFICATIONS

Year	Part Number	OEM hp Rating	HP Gain	Tube Diam	IC Mount	Drive System	Bypass System	Fuel System Upgrade	Fuel Inj. Supplied	Computer/Ignition Modifications	SC Warranty (in months)	CARB E.O.	Foot Notes
2008-13	1GQ212-SCI	430	45-50%+	3"	V	stk 6 rib	ProFlow	not required	50 lb/hr	programmer sup.	12, 36 opt. (\$99)	-	L: 1, 2, 3, 4, 6, 8, 9, 10, 11, 12
2008-13	1GQ202-SCI	430	specify	3"	V	stk 6 rib	ProFlow	not supplied	no	not supplied	12	-	L: 1, 2, 3, 6, 8, 9, 10, 11, 12
2008-13	1GQ314-SCI	430	45-50%+	3"	V	add'l 6 rib	ProFlow	not required	50 lb/hr	programmer sup.	12, 36 opt. (\$99)	-	L: 1, 2, 3, 4, 5, 6, 8, 9, 10, 11, 12
2008-13	1GQ304-SCI	430	specify	3"	V	add'l 6 rib	ProFlow	not supplied	no	not supplied	12	-	L: 1, 2, 3, 5, 6, 8, 9, 10, 11, 12
2008-13	1GQ402-SCI	430	specify	4"	V	add'l 10 rib	Race	not supplied	no	not supplied	-	-	L: 1, 2, 3, 7, 8, 9, 10, 11, 12
2008-13	1GQ402-F1C-SCI	430	specify	4"	V	add'l 10 rib	Race	not supplied	no	not supplied	-	-	L: 1, 2, 3, 6, 7, 8, 9, 10, 11, 12

## 2006-13 CORVETTE C6 Z06 (LS7) SPECIFICATIONS

Year	Part Number	OEM hp Rating	HP Gain	Tube Diam	IC Mount	Drive System	Bypass System	Fuel System Upgrade	Fuel Inj. Supplied	Computer/Ignition Modifications	SC Warranty (in months)	CARB E.O.	Foot Notes
2006-13	1GP214-SCI	505	40%+	3"3/5"	V	stk 6 rib	ProFlow	not required	65 lb/hr	programmer sup.	12, 36 opt. (\$99)	-	L: 1, 2, 4, 6, 8, 10, 11, 12
2006-13	1GP204-SCI	505	specify	3"3/5"	V	stk 6 rib	ProFlow	not supplied	No	not supplied	12	-	L: 1, 2, 6, 8, 10, 11, 12
2006-13	1GP314-SCI	505	40%+	3"3/5"	V	add'l 6 rib	ProFlow	not required	65 lb/hr	programmer sup.	12, 36 opt. (\$99)	-	L: 1, 2, 4, 5, 6, 8, 10, 11, 12
2006-13	1GP304-SCI	505	specify	3"3/5"	V	add'l 6 rib	ProFlow	not supplied	No	not supplied	12	-	L: 1, 2, 5, 6, 8, 10, 11, 12
2006-13	1GP404-SCI	505	specify	4"	V	add'l 10 rib	Race	not supplied	No	not supplied	-	-	L: 1, 2, 6, 7, 8, 10, 11, 12
2006-13	1GP404-F1C-SCI	505	specify	4"	V	add'l 10 rib	Race	not supplied	No	not supplied	-	-	L: 1, 2, 6, 7, 8, 10, 11, 12

## 2005-07 CORVETTE C6 (LS2) SPECIFICATIONS

Year	Part Number	OEM hp Rating	HP Gain	Tube Diam	IC Mount	Drive System	Bypass System	Fuel System Upgrade	Fuel Inj. Supplied	Computer/Ignition Modifications	SC Warranty (in months)	CARB E.O.	Foot Notes
2005-07	1GP202-SCI	400	50%+	3"3/5"	V	stk 6 rib	ProFlow	not required	57 lb/hr	programmer sup.	12, 36 opt. (\$99)	D-365-6 (05)	L: 1, 2, 3, 8, 10, 11, 12
2005-07	1GP212-SCI	400	specify	3"3/5"	V	stk 6 rib	ProFlow	not supplied	No	not supplied	12	-	L: 1, 2, 3, 8, 10, 11, 12
2005-07	1GP315-SCI	400	50%+	3"3/5"	V	add'l 6 rib	ProFlow	not required	57 lb/hr	programmer sup.	12, 36 opt. (\$99)	-	L: 1, 2, 3, 4, 5, 8, 10, 11, 12
2005-07	1GP305-SCI	400	specify	3"3/5"	V	add'l 6 rib	ProFlow	not supplied	No	not supplied	12	-	L: 1, 2, 3, 5, 8, 10, 11, 12
2005-07	1GP402-SCI	400	specify	4"	V	add'l 10 rib	Race	not supplied	No	not supplied	-	-	L: 1, 2, 3, 7, 8, 10, 11, 12
2005-07	1GP402-F1C-SCI	400	specify	4"	V	add'l 10 rib	Race	not supplied	No	not supplied	-	-	L: 1, 2, 3, 7, 8, 10, 11, 12

## 2008-13 CORVETTE C6 (LS3) i-1 SPECIFICATIONS

Year	Part Number	OEM hp Rating	HP Gain	Tube Diam	IC Mount	Drive System	Bypass System	Fuel System Upgrade	Fuel Inj. Supplied	Computer/Ignition Modifications	SC Warranty (in months)	CARB E.O.	Foot Notes
2008-13	1GQ312-SCI	430	50%+	3"	V	stk 6 rib	ProFlow	pump voltage booster	50 lb/hr	programmer sup.	12, 36 opt. (\$149)	-	L: 1, 2, 3, 4, 8, 9, 11, 12, 13

### CHEVROLET AUTOMOTIVE FOOTNOTES (specific to above applications):

- L1) Model year and manual or automatic transmission must be specified
- L2) Satin finish is now standard for Corvette systems; polished finish and black finish is optional
- L3) Specify wet or dry oil sump
- L4) Due to variability among OEM computers, the prevalence of custom modifications, and age/miles/condition of vehicles, dyno tuning may be required
- L5) 8-rib drive system upgrade is available for 2005-13 C6 and Grand Sport Stage II Systems/Tuner Kits and requires ATI PP balancer #917345 (LS3/LS2, wet sump) or #918620 (LS7/GS, dry sump) (not supplied), or Innovator's West balancer #843 (LS3/LS2, wet sump) or #853 (LS7/GS, dry sump) (not included - specify hardened hub)
- L6) 2009-13 models require water pump modification (water pump available from ProCharger)
- L7) Requires 10-rib ATI PP balancer #917347X (LS3/LS2, wet sump) (not supplied), or Innovator's West balancer #844 (LS3/LS2, wet sump) or #854 (LS7/GS, dry sump) (not included - specify hardened hub)
- L8) System ships in extra large box
- L9) Grand Sport Corvette applications must be noted at time of order, including body style
- L10) Race intercooler option requires oil cooler relocation (not supplied)
- L11) Specify stock or aftermarket balancer
- L12) Two-part shipment, additional shipping charges may apply
- L13) Special order kit: order form and non-refundable deposit required at time of order—may require additional lead time for processing



## 1997-04 CORVETTE C5 (LS1) SYSTEMS AND KITS

Year	Part Number	Description	Boost Options	HP Gain	Intercooler	Price/MAP
1999-04 (LS1)	1GK213-SCI	High Output Intercooled System with P-1SC-1 (satin finish, shared 6 rib)	7 psi	55%+	4.5" twin highflow	\$7,899
1997-04 (LS1)	1GK203-SCI	High Output Intercooled Tuner Kit with P-1SC-1 (satin finish, shared 6 rib)	specify	specify	4.5" twin highflow	\$6,999
1999-04 (LS1)	1GK414-SCI	Stage II Intercooled System with P-1SC-1 (satin finish)	7 psi	55%+	4.5" twin highflow	\$8,649
1997-04 (LS1)	1GK404-SCI	Stage II Intercooled Tuner Kit with P-1SC-1 (satin finish)	specify	specify	4.5" twin highflow	\$7,699

## 2001-04 CORVETTE C5 Z06 (LS6) SYSTEMS AND KITS

Year	Part Number	Description	Boost Options	HP Gain	Intercooler	Price/MAP
2001-04 (LS6)	1GK216-SCI	High Output Intercooled System with P-1SC-1 (satin finish, shared 6 rib)	6 psi	50%+	4.5" twin highflow	\$7,899
2001-04 (LS6)	1GK206-SCI	High Output Intercooled Tuner Kit with P-1SC-1 (satin finish, shared 6 rib)	specify	specify	4.5" twin highflow	\$6,999
2001-04 (LS6)	1GK219-SCI	Stage II Intercooled System with P-1SC-1 (satin finish)	6 psi	50%+	4.5" twin highflow	\$8,649
2001-04 (LS6)	1GK209-SCI	Stage II Intercooled Tuner Kit with P-1SC-1 (satin finish)	specify	specify	4.5" twin highflow	\$7,799

1997-04 C5 & Z06 ALL	add "-B" or "-P" to part #	Black or Polished Finish for supercharger and bracket (P or D-series)	satin standard	-	-	+\$595
	add "-H" to part #	Helical gearset for noise reduction (P-1SC-1, P-1X, D-1SC, D-1X)	same	same	-	+\$110
	add "-D1SC" to part #	With D-1SC ProCharger (replacing P-1SC-1)	tuner kit only	specify	-	+\$275
1997-04 C5 & Z06 (LS1, LS6) STAGE II ONLY	add "-P1X" to part #	With P-1X ProCharger (replacing P-1SC-1, Stage II Systems and Tuner Kits)	same	add'l 10-15+ hp	-	+\$250
	add "-D1X" to part #	With D-1X ProCharger (replacing P-1SC-1, Stage II Tuner Kits only)	tuner kit only	specify	-	+\$475
	add "-D" or "-1" or "-A"	With F-1D, F-1, F-1A (replacing P-1SC-1, Stage II Tuner Kits only, 8 rib required)	tuner kit only	specify	-	+\$875
	add "-94" to part #	With F1A-94 (replacing P-1SC-1, Stage II Tuner Kits only, 8 rib required)	tuner kit only	specify	-	+\$1,225
	add "-8R" to part #	8 rib dedicated drive upgrade (Stage II, time of purchase, see footnotes)	from 6 rib	specify	-	+\$360
	add "-RVR" or "RVB"	Race Bypass Valve Upgrade (Stage II only)	red or black	specify	-	+\$295

## 1992-96 CORVETTE C4 (LT1, LT4) SYSTEMS AND KITS

Year	Part Number	Description	Boost Options	HP Gain	Intercooler	Price/MAP
1992-96 (LT1)	1GF211-SCI	High Output Intercooled System with P-1SC (satin finish)	8 psi	55-60%	LT1 Vette 2 core	\$7,199
1992-96 (LT1)	1GF201-SCI	High Output Intercooled Tuner Kit with P-1SC (satin finish)	specify	specify	LT1 Vette 2 core	\$6,849
1996 (LT4)	1GF212-SCI	High Output Intercooled System with P-1SC (satin finish)	6 psi	45-50%	LT1 Vette 2 core	\$7,199
1996 (LT4)	1GF202-SCI	High Output Intercooled Tuner Kit with P-1SC (satin finish)	specify	specify	LT1 Vette 2 core	\$6,849

1992-96 C4 (LT1, LT4) OPTIONS	add "-P" to part #	Polished Finish for supercharger and bracket (satin standard)	satin standard	-	-	+\$595
	add "-H" to part #	Helical gearset for noise reduction (P-1SC, D-1SC)	same	same	-	+\$110
	add "-D1SC" to part #	With D-1SC ProCharger (replacing P-1SC)	tuner kit only	specify	-	+\$495
	MA001I-001	Mass Airflow Massager (required for 1996 only)	1996 only	-	-	+\$249

## 1985-91 CORVETTE C4 TPI (L98) SYSTEMS AND KITS

Year	Part Number	Description	Boost Options	HP Gain	Intercooler	Price/MAP
1985-91 (L98)	1GB212-08I	High Output Intercooled System with P600B (satin finish)	8 psi	55-75%	2 core (85-89) Twin (90-91)	\$6,799
1985-91 (L98)	1GB211-06S	High Output Kit with P600B (satin finish)	specify	specify	-	\$5,699
1985-91 (L98)	1GB212-D1	High Output Intercooled System with D-1 (satin finish)	10+ psi	75%+	2 core (85-89) Twin (90-91)	\$7,299
1985-91 (L98)	1GB211-D1	High Output Tuner Kit with D-1 (satin finish)	specify	specify	-	\$6,199

1985-91 TPI (L98) OPTIONS	add "-P" to part #	Polished Finish for supercharger and bracket (satin standard)	satin standard	-	-	+\$595
	add "-OF" to part #	Omit FMU (D-1 system only)	-	-	-	-\$88
	add "-OP" to part #	Omit in-line fuel pump (D-1 system only)	-	-	-	-\$98

# SPECIFICATIONS (C5/C4 CORVETTE)

## 1997-04 CORVETTE C5 (LS1) SPECIFICATIONS

Year	Part Number	OEM hp Rating	HP Gain	Tube Diam	IC Mount	Drive System	Bypass System	Fuel System Upgrade	Fuel Inj. Supplied	Computer/Ignition Modifications	Supercharger Warranty (in months)	CARB E.O.	Foot Notes
1999-04	1GK213-SCI	345	55%+	3" ea	Twin	stk 6 rib	ProFlow	not required	38 lb/hr	programmer sup.	12, 36 opt. (\$99)	D-365-6	M1, M2, M4, M5
1999-04	1GK203-SCI	345	specify	3" ea	Twin	stk 6 rib	ProFlow	not supplied	No	not supplied	12	-	M1, M2, M4, M5
1999-04	1GK414-SCI	345	55%+	3" ea	Twin	add'l 6 rib	ProFlow	not supplied	38 lb/hr	programmer sup.	12	-	M1, M2, M3, M4, M5
1999-04	1GK404-SCI	345	specify	3" ea	Twin	add'l 6 rib	ProFlow	not supplied	No	not supplied	12	-	M1, M2, M4, M5

## 2001-04 CORVETTE C5 Z06 (LS6) SPECIFICATIONS

Year	Part Number	OEM hp Rating	HP Gain	Tube Diam	IC Mount	Drive System	Bypass System	Fuel System Upgrade	Fuel Inj. Supplied	Computer/Ignition Modifications	Supercharger Warranty (in months)	CARB E.O.	Foot Notes
2001-04	1GK216-SCI	405	50%+	3" ea	Twin	stk 6 rib	ProFlow	not required	38 lb/hr	programmer sup.	12, 36 opt. (\$99)	D-365-6	M1, M2, M4, M5
2001-04	1GK206-SCI	405	specify	3" ea	Twin	stk 6 rib	ProFlow	not supplied	No	not supplied	12	-	M1, M2, M4, M5
2001-04	1GK219-SCI	405	50%+	3" ea	Twin	add'l 6 rib	ProFlow	not supplied	38 lb/hr	programmer sup.	12	-	M1, M2, M3, M4, M5
2001-04	1GK209-SCI	405	specify	3" ea	Twin	add'l 6 rib	ProFlow	not supplied	No	not supplied	12	-	M1, M2, M4, M5

## 1992-96 CORVETTE C4 (LT1, LT4) SPECIFICATIONS

Year	Part Number	OEM hp Rating	HP Gain	Tube Diam	IC Mount	Drive System	Bypass System	Fuel System Upgrade	Fuel Inj. Supplied	Computer/Ignition Modifications	Supercharger Warranty (in months)	CARB E.O.	Foot Notes
1992-96	1GF211-071 / 091	300	55-60%	3"	V	stk 6 rib	Bosch	ProPump, FMU	not req.	not required	12, 36 opt. (\$99)	D-365-3 (92-95)	M1, M2, M7, M11, M12
1992-96	1GF201-SCI	300	specify	3"	V	stk 6 rib	Bosch	not supplied	No	not supplied	12	-	M1, M2, M7, M11, M12
1996	1GF212-SCI	330	45-50%	3"	V	stk 6 rib	Bosch	ProPump, FMU	not req.	not required	12, 36 opt. (\$99)	-	M1, M2, M3, M7, M11, M12
1996	1GF202-SCI	330	specify	3"	V	stk 6 rib	Bosch	not supplied	No	not supplied	12	-	M1, M2, M8, M11, M12

## 1985-91 CORVETTE C4 TPI (L98) SPECIFICATIONS

Year	Part Number	OEM hp Rating	HP Gain	Tube Diam	IC Mount	Drive System	Bypass System	Fuel System Upgrade	Fuel Inj. Supplied	Computer/Ignition Modifications	Supercharger Warranty (in months)	CARB E.O.	Foot Notes
1985-91	1GB212-081	230-250	55-75%	2.5"	V or Twin	stk 6 rib	Bosch	ProPump, FMU	not req.	not required	36	D-365-3	M1, M2, M5, M9 (12 psi), M10, M11, M13
1985-91	1GB211-06S	230-250	specify	3"	-	stk 6 rib	not required	not supplied	No	not required	36	-	M1, M2, M10, M11, M13
1985-91	1GB212-D1	230-250	75%+	2.5"	V or Twin	stk 6 rib	Bosch	ProPump, FMU	No	not required	12	-	M1, M2, M3, M5, M9 (12 psi), M10, M11, M13
1985-91	1GB211-D1	230-250	specify	3"	-	stk 6 rib	not supplied	-	No	not required	12	-	M1, M2, M5, M8, M10, M11, M13

## CHEVROLET AUTOMOTIVE FOOTNOTES (specific to above applications):

- M1) Model year and manual or automatic transmission must be specified
- M2) Satin finish is now standard for Corvette systems; polished finish is optional
- M3) Due to variability among OEM computers, the prevalence of custom modifications, and age/miles/condition of vehicles, dyno tuning may be required
- M4) 8-rib drive system upgrade is available for 1997-04 LS1 Stage II Systems/Tuner Kits and requires ATI PP balancer #917345 (LS1, wet sump) or #918620 (LS6) - not supplied
- M5) System ships in extra large box
- M7) Mass airflow massager required for 1996 LT1's (sold separately by ProCharger)
- M8) Modified engines only
- M9) Larger fuel injectors may be required (sold separately by others)
- M10) Some GM suspension options may require slight modification to hood reinforcement or supercharger bracket
- M11) Special order kit: order form and non-refundable deposit required at time of order—may require additional lead time for processing
- M12) A/C line may need to be modified or removed
- M13) Does not work with magnetic ride control



## 2016-23 CAMARO SS (LT1) SYSTEMS AND KITS

Year	Part Number	Description	Boost Options	HP Gain	Intercooler	Price/MAP
2016-23	1GY211-SCI	Intercooled System with Factory Airbox and P-1SC-1 only	7 psi	150+ hp	3 core	\$7,899
2016-23	"-add SII"	Stage II Intercooler Option for Factory Airbox System P-1SC-1 only	7 psi	Add'l 20+ hp	From 3 core	+\$445
2016-23	1GY201-SCI	Intercooled Tuner Kit with Factory Airbox	specify	specify	3 core	\$7,499
2016-23	1GY212-SCI	High Output Intercooled System with P-1SC-1	7 psi	150+ hp	3 core	\$7,799
2016-23	1GY202-SCI	High Output Intercooled Tuner Kit with P-1SC-1	specify	specify	3 core	\$7,449
2016-23	1GY312-SCI	Stage II Intercooled System with P-1SC-1	7 psi	170+ hp	Stage II	\$8,299
2016-23	1GY302-SCI	Stage II Intercooled Tuner Kit with P-1SC-1	specify	specify	Stage II	\$7,949
2016-23	1GY402-F1	Competition Race Tuner Kit with F-1D, F-1 or F-1A	specify	specify	1250+ hp AW	\$11,299
2016-23	1GY402-SCI-94	Competition Race Tuner Kit with F-1A-94, F-1C or F-1R	specify	specify	1250+ hp AW	\$11,649

## 2017-21 CAMARO ZL1 (LT4) KITS

Year	Part Number	Description	Boost Options	HP Gain	Intercooler	Price/MAP
2017-21	1GY204-SCI	Stage II Intercooled Tuner Kit with D-1SC	specify	specify	Stage II	\$9,649
2017-21	1GY404-F1	Intercooled Race Tuner Kit with F-1D, F-1 or F-1A	specify	specify	Race	\$10,499
2017-21	1GY404-SCI-94	Intercooled Race Tuner Kit with F-1A-94, F-1C or F-1R	specify	specify	Race	\$10,849
2017-21	1GY300-F1	Competition Race Tuner Kit with F-1D, F-1 or F-1A	specify	specify	1250+ hp AW	\$12,649
2017-21	1GY300-SCI-94	Competition Race Tuner Kit with F-1A-94, F-1C or F-1R	specify	specify	1250+ hp AW	\$12,999

## 2016-21 CAMARO V6 (3.6) SYSTEM AND KIT

Year	Part Number	Description	Boost Options	HP Gain	Intercooler	Price/MAP
2016-21	1GZ212-SCI	High Output Intercooled System with P-1SC-1	7 psi	45%	750+ hp	\$6,549
2016-21	1GZ202-SCI	High Output Intercooled Tuner Kit with P-1SC-1	specify	specify	750+ hp	\$6,149

## 2016-19 CADILLAC CTS-V (LT4)

Year	Part Number	Description	Boost Options	HP Gain	Intercooler	Price/MAP
2016-19	1GY704-SCI	Stage II Intercooled Tuner Kit with D-1SC	specify	specify	Stage II	\$9,649

CTS-V, SS, ZL1, V6 OPTIONS	add "-B" or "-P" to part #	Black or Polished finish for ProCharger (P-series or D-series)	satin standard	-	-	+\$325
	add "-B" or "-P" to part #	Black or Polished finish for ProCharger (F-series, 9" or 9.75" housing)	satin standard	-	-	+\$350
	add "-BB" or "-PB" to part #	Black or Polished finish for supercharger bracket	satin standard	-	-	+\$275
CAMARO SS OPTIONS ONLY	add "-H" to part #	Helical gearset for noise reduction (P-1SC-1, P-1X, D-1SC, D-1X)	same	same	-	+\$110
	add "-RVR" or "RVB"	Race Bypass Valve (open only, already included in Race kits)	red or black	specify	-	+\$295
	add "-P1X" to part #	With P-1X ProCharger (replacing P-1SC-1, not available for SS factory airbox)	same	add'l 10-15+ hp	-	+\$250
	add "-D1SC" to part #	With D-1SC ProCharger (replacing P-1SC-1 - Stage II only)	tuner kit only	specify	-	+\$275
	add "-D1X" to part #	With D-1X ProCharger (replacing P-1SC-1 - Stage II only, not available for factory airbox)	tuner kit only	specify	-	+\$475
	add "-D" or "-1" or "-A"	With F-1D, F-1 or F-1A ProCharger (replacing P-1SC-1)	tuner kit only	specify	-	+\$875
	add "-94"	With F-1A-94 (replacing P-1SC-1, Stage II Tuner kits only, not available for factory airbox)	tuner kit only	-	-	+\$1,225
	add "-INT" to part #	Sheet Metal Aluminum Intake Manifold/Cover (Stage II Tuner Kit Only)	unfinished std	-	-	+\$2,498
CTS-V AND ZL1 OPTIONS ONLY	add "-INT/INJ" to part #	Sheet Metal Aluminum Intake Manifold w/ injector bungs and fuel rails (Stage II only)	tuner kit only	-	-	+\$2,998
	add "-D1X" to part #	With D-1X ProCharger (replacing D-1SC)	tuner kit only	specify	-	+\$200
	add "-D" or "-1" or "-A"	With F-1D, F-1 or F-1A ProCharger (replacing D-1SC)	tuner kit only	specify	-	+\$599
	add "-94"	With F-1A-94 (replacing D-1SC, Stage II Tuner kits only)	tuner kit only	-	-	+\$850
CTS-V, CAMARO SS, ZL1 ONLY	add "-INT/INJ" to part #	Sheet Metal Aluminum Intake Manifold w/ injector bungs and fuel rails	unfinished std	-	-	+\$500
	add "-BI" to part #	Black Finish for Intake Manifold (unfinished standard)	unfinished std	-	-	+\$225
	add "-BC" to part #	Black Finish for Intake Manifold Cover (unfinished standard)	unfinished std	-	-	+\$35
	add "-10R" to part #	10 Rib Belt Drive Upgrade	tuner kit only	-	-	+\$360
	add "-ATIPP" to part #	ATI Performance Products Balancer Upgrade (# 918856)	-	-	-	+\$525
	add "-CP" to part #	8.25" Crank Pulley Upgrade	7.65" standard	-	-	+\$120
ZL1 ONLY	add "-Race" to part #	Air-to-Air Race Intercooler (Stage II Tuner Kits only)	from Stage II	specify	-	+\$435
	add "-AWR" to part #	Air-to-Water Race Intercooler (Camaro Stage II Tuner kits only)	from Stage II	specify	-	+\$2,499
V6 ONLY	add "-AIR" to part #	Stage II Air Inlet Upgrade Package (Replacing Factory Airbox)	same	specify	-	+\$45



# SPECIFICATIONS (2016-23 CAMARO AND CTS-V)

## 2016-23 CAMARO SS (LT1) SPECIFICATIONS

Year	Part Number	OEM hp Rating	HP Gain	Tube Diam	Intercooler Mount	Drive System	Bypass System	Fuel System Upgrade	Fuel Inj. Supplied	Computer/Ignition Modifications	Supercharger Warranty (in months)	CARB E.O.	Foot Notes
2016-23	1GY211-SCI	455	150+ hp	3"	V	stk 6 rib	Bullet	not required	not required	programmer supplied	12, 36 opt. (\$99)	D-365-29 (16-21)	N1, N3, N10
2016-23	"add -SII"	455	Add'l 20+ hp	3"	V	stk 6 rib	Bullet	not supplied	not required	programmer supplied	12, 36 opt. (\$99)	D-365-29 (16-21)	N1, N3, N10
2016-23	1GY201-SCI	455	specify	3"	V	stk 6 rib	Bullet	not supplied	no	not supplied	12	-	N1, N3, N5, N10
2016-23	1GY212-SCI	455	150+ hp	3"	V	add'l 8 rib	ProFlow	not required	not required	programmer supplied	12, 36 opt. (\$99)	-	N1, N2, N3, N4, N5, N9
2016-23	1GY202-SCI	455	specify	3"	V	add'l 8 rib	ProFlow	not supplied	no	not supplied	12	-	N1, N3, N4, N5, N9
2016-23	1GY312-SCI	455	170+ hp	3"	V	add'l 8 rib	ProFlow	not required	not required	programmer supplied	12, 36 opt. (\$99)	-	N1, N2, N3, N4, N5, N6, N9
2016-23	1GY302-SCI	455	specify	3"	V	add'l 8 rib	ProFlow	not supplied	no	not supplied	12	-	N1, N3, N4, N5, N6, N9
2016-23	1GY402-F1	455	specify	3"	V	add'l 8 rib	Race	not supplied	no	not supplied	12	-	N1, N3, N4, N5, N6, N9
2016-23	1GY402-SCI-94	455	specify	3"	V	add'l 8 rib	Race	not supplied	no	not supplied	12	-	N1, N3, N4, N5, N6, N9

## 2017-21 CAMARO ZL1 (LT4) SPECIFICATIONS

Year	Part Number	OEM hp Rating	HP Gain	Tube Diam	Intercooler Mount	Drive System	Bypass System	Fuel System Upgrade	Fuel Inj. Supplied	Computer/Ignition Modifications	Supercharger Warranty (in months)	CARB E.O.	Foot Notes
2017-21	1GY204-SCI	650	specify	3"	V	add'l 8 rib	Bullet	not supplied	no	not supplied	12	-	N1, N3, N7, N8, N9
2017-21	1GY404-F1	650	specify	3"	V	add'l 8 rib	Race	not required	no	not supplied	12	-	N1, N3, N7, N8, N9
2017-21	1GY404-SCI-94	650	specify	3"	V	add'l 8 rib	Race	not supplied	no	not supplied	12	-	N1, N3, N6, N7, N8, N9
2017-21	1GY300-F1	650	specify	3"	A/W	add'l 8 rib	Race	not supplied	no	not supplied	12	-	N1, N3, N7, N8, N9
2017-21	1GY300-SCI-94	650	specify	3"	A/W	add'l 8 rib	Race	not supplied	no	not supplied	12	-	N1, N3, N6, N7, N8, N9

## 2016-21 CAMARO V6 (3.6) SPECIFICATIONS

Year	Part Number	OEM hp Rating	HP Gain	Tube Diam	Intercooler Mount	Drive System	Bypass System	Fuel System Upgrade	Fuel Inj. Supplied	Computer/Ignition Modifications	Supercharger Warranty (in months)	CARB E.O.	Foot Notes
2016-21	1GZ212-SCI	335	call	3"	V	stk 6 rib	ProFlow	not required	not required	programmer supplied	12, 36 opt. (\$99)	D-365-27	N1, N3, N10
2016-21	1GZ202-SCI	335	specify	3"	V	stk 6 rib	ProFlow	not supplied	no	not supplied	12	-	N1, N3, N10

## 2016-19 CADILLAC CTS-V (LT4) SPECIFICATIONS

Year	Part Number	OEM hp Rating	HP Gain	Tube Diam	Intercooler Mount	Drive System	Bypass System	Fuel System Upgrade	Fuel Inj. Supplied	Computer/Ignition Modifications	Supercharger Warranty (in months)	CARB E.O.	Foot Notes
2016-19	1GY704-SCI	650	specify	3"	V	add'l 8 rib	Bullet	not supplied	no	not supplied	12	-	N1, N3, N8, N9

## CHEVROLET AUTOMOTIVE FOOTNOTES (specific to above applications):

- N1) Model year must be specified
- N2) Due to variability among OEM computers, the prevalence of custom modifications, and age/miles/condition of vehicles, dyno tuning may be required
- N3) System ships in extra large box
- N4) Race intercooler upgrades requires trimming and removal of driver-side radiator
- N5) Specify stock or aftermarket balancer
- N6) Inner fender modifications required for F-1C and F-1R head units
- N7) Inner bumper support modification or removal required for Race and Air-to-Water intercoolers
- N8) Requires ATI PP balancer #918856 (not included - specify hardened hub)
- N9) Works with maximum of 10% overdrive crank pulley
- N10) Factory balancer only



## 2010-15 CAMARO SS (LS3, L99) SYSTEMS AND KITS

Year	Part Number	Description	Boost Options	HP Gain	Intercooler	Price/MAP
2010-15	1GT214-SCI	High Output Intercooled System with supplied airbox and P-1SC-1	7 psi	50%+	3 core	\$8,499
2010-15	1GT212-SCI	High Output Intercooled System with P-1SC-1	7 psi	50%+	3 core	\$8,349
2010-15	1GT202-SCI	High Output Intercooled Tuner Kit with P-1SC-1	specify	specify	3 core	\$7,599
2010-15	1GT314-SCI	Stage II Intercooled System with supplied airbox and P-1SC-1	7.5 psi	55%+	Race	\$9,199
2010-15	1GT312-SCI	Stage II Intercooled System with P-1SC-1	7.5 psi	55%+	Race	\$9,049
2010-15	1GT302-SCI	Stage II Intercooled Tuner Kit with P-1SC-1	specify	specify	Race	\$8,299

## 2014-15 CAMARO Z/28 (LS7) SYSTEMS AND KITS

Year	Part Number	Description	Boost Options	HP Gain	Intercooler	Price/MAP
2014-15	1GT414-SCI	Stage II Intercooled System with P-1SC-1	6.5 psi	120+ hp	750+ hp	\$8,999
2014-15	1GT404-SCI	Stage II Intercooled Tuner Kit with P-1SC-1	specify	specify	750+ hp	\$8,099

2014-15 CAMARO Z/28 (LS7) AND 2010-15 CAMARO SS (LS3, L99) OPTIONS	add "-B" or "-P" to part #	Black or Polished finish for ProCharger (P-series or D-series )	satin standard	-	-	+\$325	
	add "-B" or "-P" to part #	Black or Polished finish for ProCharger (F-series, 9" or 9.75" housing)	satin standard	-	-	+\$350	
	add "-B" or "-P" to part #	Black or Polished finish for ProCharger (F-series, 10.5" housing)	satin standard	-	-	+\$375	
	add "-BB" or "-PB" to part #	Black or Polished finish for supercharger bracket	satin standard	-	-	+\$275	
	add "-H" to part #	Helical gearset for noise reduction (P-1SC-1, P-1X, D-1SC, D-1X)	same	same	-	+\$110	
	add "-P1X" to part #	With P-1X ProCharger (replacing P-1SC-1, Systems and Tuner Kits)	same	add'l 10-15+ hp	-	+\$250	
	add "-D1SC" to part #	With D-1SC ProCharger (replacing P-1SC-1)	tuner kit only	specify	-	+\$275	
	add "-D1X" to part #	With D-1X ProCharger (replacing P-1SC-1, Tuner Kits only)	tuner kit only	specify	-	+\$475	
	add "-D" or "-1" or "-A"	With F-1D, F-1, F-1A ProCharger (replacing P-1SC-1)	tuner kit only	specify	-	+\$875	
CAMARO SS (LS3, L99) ONLY	add "-94" or "-C" or "-R"	With F-1A-94, F-1C or F-1R ProCharger (replacing P-1SC-1)	tuner kit only	-	-	+\$1,225	
	add "-RV" to part #	Race Bypass Valve Upgrade (specify open or closed valve)	red or black	specify	-	+\$295	
	add "-F1X" to part #	With F-1X ProCharger (replacing P-1SC-1)	tuner kit only	-	-	+\$2,490	
	add "-AIR" to part #	With Stage II air inlet upgrade package (replacing std inlet)	same	specify	-	+\$45	
	add "-10R" to part #	10 rib drive system upgrade (Stage II Tuner Kits only)	from 8 rib	specify	-	+\$360	
	add "-3R" to part #	With Sheet Metal 3 Core Race Intercooler (1300 hp)	from Race	-	-	+\$435	
	add "-ATIPP" to part #	ATI Performance Products Balancer Upgrade	-	-	-	+\$525	
	Z/28 ONLY	add "-Race" to part #	1200+ hp Intercooler Upgrade (replacing 750+ hp intercooler)	from 750+ hp	1200+ hp	-	+\$435

## 2010-15 CAMARO SS (LS3, L99) i-1 PROGRAMMABLE RATIO SYSTEMS

Year	Part Number	Description	Boost Options	HP Gain	Intercooler	Price/MAP
2010-15	1GT313-SCI	Stage II Intercooled System with i-1	7.5 psi	55%+	Race	\$10,399

i-1 OPTIONS	add "-T" to part #	Touchscreen (at time of system purchase)	-	-	-	+\$395
	add "-B" to part #	Black finish (supercharger and bracket)	satin standard	-	-	+\$795
	add "-P" to part #	Polished finish (supercharger and bracket)	satin standard	-	-	+\$595
	add "-ATIPP" to part #	ATI Performance Products Balancer Upgrade	-	-	-	+\$525

## 2010-15 CAMARO SS COG RACE KITS

Year	Part Number	Description	Boost Options	HP Gain	Intercooler	Price/MAP
2010-15	1GT200-F1I	Intercooled Cog Race Kit with F-1D, F-1, or F-1A	specify	specify	Race	\$9,999
2010-15	1GT200-F1	Cog Race Kit with F-1D, F-1, or F-1A	specify	specify	-	\$8,499

2010-15 CAMARO SS COG RACE OPTIONS	add "-94" or "-C" or "-R"	With F-1A-94, F-1C or F-1R ProCharger (replacing F-1D, F-1 or F-1A)	from F-1/D/A	specify	-	+\$350
	add "-F1X" to part #	With F-1X ProCharger (replacing F-1D, F-1, or F-1A)	from F-1/D/A	specify	-	+\$1,240
	add "-3R" to part #	With sheet metal 3 core race intercooler (1300 hp)	from Race	3.5" in/outlet	-	+\$435
	WI1005A-001	With Air-to-Water race intercooler (race use only)	from non-ic kit	1,800 hp max	-	+\$2,498
	WI1005A-002	With Air-to-Water race intercooler (race use only)	from non-ic kit	2,500+ hp max	-	+\$2,998

## 2010-2015 V6 COMING SOON

# SPECIFICATIONS (2010-15 CAMARO)

## 2010-15 CAMARO SS (LS3, L99) SPECIFICATIONS

Year	Part Number	OEM hp Rating	HP Gain	Tube Diam	Intercooler Mount	Drive System	Bypass System	Fuel System Upgrade	Fuel Inj. Supplied	Computer/Ignition Modifications	Supercharger Warranty (in months)	CARB E.O.	Foot Notes
2010-15	1GT214-SCI	426/400	50%+	3"	V	add'l 8 rib	ProFlow	not required	50 lb/hr	programmer supplied	12, 36 opt. (\$99)	D-365-13	O1, O4, O6
2010-15	1GT212-SCI	426/400	50%+	3"	V	add'l 8 rib	ProFlow	not required	50 lb/hr	programmer supplied	12, 36 opt. (\$99)	-	O1, O2, O4, O6
2010-15	1GT202-SCI	426/400	specify	3"	V	add'l 8 rib	ProFlow	not supplied	no	not supplied	12	-	O1, O4, O6, O10
2010-15	1GT314-SCI	426/400	55%+	3"	V	add'l 8 rib	ProFlow	pump voltage booster	50 lb/hr	programmer supplied	12, 36 opt. (\$99)	D-365-13	O1, O3, O4, O6
2010-15	1GT312-SCI	426/400	55%+	3"	V	add'l 8 rib	ProFlow	pump voltage booster	50 lb/hr	programmer supplied	12, 36 opt. (\$99)	-	O1, O2, O3, O4, O6
2010-15	1GT302-SCI	426/400	specify	3"	V	add'l 8 rib	ProFlow	not supplied	no	not supplied	12	-	O1, O3, O5, O4, O6, O10

## 2014-15 CAMARO Z/28 (LS7) SPECIFICATIONS

Year	Part Number	OEM hp Rating	HP Gain	Tube Diam	Intercooler Mount	Drive System	Bypass System	Fuel System Upgrade	Fuel Inj. Supplied	Computer/Ignition Modifications	Supercharger Warranty (in months)	CARB E.O.	Foot Notes
2014-15	1GT414-SCI	505	120+ hp	3"	V	add'l 8 rib	ProFlow	pump voltage booster	65 lb/hr	programmer supplied	12, 36 opt. (\$99)	-	O1, O2, O4, O5, O6
2014-15	1GT404-SCI	505	specify	3"	V	add'l 8 rib	ProFlow	not supplied	no	not supplied	12	-	O1, O4, O5, O6, O10

## 2010-15 CAMARO SS (LS3, L99) i-1 SPECIFICATIONS

Year	Part Number	OEM hp Rating	HP Gain	Tube Diam	Intercooler Mount	Drive System	Bypass System	Fuel System Upgrade	Fuel Inj. Supplied	Computer/Ignition Modifications	Supercharger Warranty (in months)	CARB E.O.	Foot Notes
2010-15	1GT313-SCI	426/400	55%+	3"	V	add'l 8 rib	ProFlow	pump voltage booster	50 lb/hr	programmer supplied	12, 36 opt. (\$149)	-	O1, O2, O3, O6, O7, O11

## 2010-15 CAMARO SS COG RACE KIT SPECIFICATIONS

Year	Part Number	OEM hp Rating	HP Gain	Tube Diam	Intercooler Mount	Drive System	Bypass System	Fuel System Upgrade	Fuel Inj. Supplied	Computer/Ignition Modifications	Supercharger Warranty (in months)	CARB E.O.	Foot Notes
2010-15	1GT200-F1-I	-	specify	3"3.5"	V	Cog	Race	not supplied	no	not supplied	Limited	-	O1, O3, O4, O5, O8, O9, O10
2010-15	1GT200-F1	-	specify	-	-	Cog	Race	not supplied	no	not supplied	Limited	-	O1, O3, O4, O5, O8, O9, O10

## CHEVROLET AUTOMOTIVE FOOTNOTES (specific to above applications):

- O1) Model year must be specified
- O2) Due to variability among OEM computers, the prevalence of custom modifications, and age/miles/condition of vehicles, dyno tuning may be required
- O3) System ships in extra large box
- O4) Race intercooler upgrades may require modifications
- O5) 2010-15 Cog and 10-rib requires ATI Balancer ATI PP #918635 (not included - specify hardened hub)
- O6) Stage II air inlet and air inlet upgrade package require auxiliary battery bracket relocation (supplied)
- O7) Two-part shipment, additional shipping charges may apply
- O8) Requires coolant hose modifications
- O9) Bracket brace and Kevlar COG belt recommended
- O10) 9.75" and larger head unit requires modification of strut tower and power steering reservoir (10-11), and inner fender
- O11) Special order kit: order form and non-refundable deposit required at time of order—may require additional lead time for processing



**1998-02 CAMARO/FIREBIRD (LS1) SYSTEMS AND KITS**

Year	Part Number	Description	Boost Options	HP Gain	Intercooler	Price/MAP
1999-02	1GJ214-SCI	<a href="#">High Output Intercooled System with P-1SC-1</a>	5, 7 psi	40-55%	3.5" twin highflow	\$8,499
1998-02	1GJ213-SCI	<a href="#">High Output Intercooled Tuner Kit with P-1SC-1</a>	specify	specify	3.5" twin highflow	\$7,649
1998-02	1GJ204-SCI	<a href="#">Intercooled Serpentine Race Kit with D-1SC (8 rib with spring tensioner)</a>	specify	specify	4.5" twin highflow	\$8,449

<b>1998-02 CAMARO AND FIREBIRD (LS1) OPTIONS</b>	add "-P" to part #	Polished Aluminum Intake Plenum (Replacing rotomold plenum)	blk rotomold std	-	-	+\$275
	add "-H" to part #	Helical gearset for noise reduction (P-1SC-1, D-1SC)	same	same	-	+\$110
	add "-D1SC" to part #	With D-1SC ProCharger (replacing P-1SC-1)	specify	specify	-	+\$275
	add "-D" or "-1" or "-A"	With F-1D, F-1, F-1A ProCharger (replacing D-1SC, Serp Race Kit only)	Race kit only	specify	-	+\$599
	add "-4.5" to part #	Upgrade to 4.5" Twin Highflow intercooler	from 3.5" Twin	-	850 hp max	+\$345
	add "-8R" to part #	8 Rib Drive System Upgrade	specify	specify	-	+\$275
	add "-10R" to part #	10 Rib Drive System Upgrade (race kit only, from 8 rib)	specify	specify	-	+\$360
	add "-3C" to part #	Race Intercooler Upgrade (race kit only, race valve and modifications req'd)	from 4.5" Twin	specify	1,300 hp max	+\$275
	add "-RVR" or "-RVB"	Race Bypass Valve Upgrade from ProFlow (race kit only, specify open or closed valve)	red or black	specify	-	+\$295
add "-ATIPP" to part #	ATI Performance Products Balancer (#918853, 8 rib and 10 rib)	-	-	-	+\$525	
	3GKMM-004	Crank Pin Kit	-	-	-	+\$109

**1993-97 CAMARO/FIREBIRD (LT1) SYSTEMS AND KITS**

Year	Part Number	Description	Boost Options	HP Gain	Intercooler	Price/MAP
1993-97	1GA211-071 / 091	<a href="#">High Output Intercooled System with P-1SC</a>	7, 9 psi	55-60%	2 core	\$6,799
1993-97	1GA201-SCI	<a href="#">High Output Intercooled Tuner Kit with P-1SC</a>	specify	specify	2 core	\$6,499
1993-97	1GA212-D1SC	<a href="#">Intercooled Serpentine Race Kit with D-1SC (12 rib)</a>	specify	specify	twin highflow	\$7,399

<b>1993-97 CAMARO AND FIREBIRD (LT1) OPTIONS</b>	add "-B" or "-P" to part #	Black or Polished finish for ProCharger (P-series or D-series)	satin standard	-	-	+\$325
	add "-I" to part #	Polished finish for intake tract	satin standard	-	-	+\$175
	add "-H" to part #	Helical gearset for noise reduction (P-1SC, D-1SC)	same	same	-	+\$110
	add "-D1SC" to part #	With D-1SC ProCharger (replacing P-1SC)	HO kit only	specify	-	+\$495
	add "-D" or "-1" or "-A"	With F-1D, F-1, F-1A ProCharger (replacing D-1SC, Serp Race Kit only)	Race kit only	specify	-	+\$599
	add "-RVR" or "-RVB"	Race Bypass Valve Upgrade (specify open or closed valve; red or black)	from ProFlow	specify	-	+\$295
	add "-THF" to part #	Twin Highflow intercooler upgrade	from 2 core	-	750 hp max	+\$495
	MA0011-001	Mass Airflow Massager (required for 96-97 only)	-	-	-	+\$249

**1987-92 CAMARO/FIREBIRD TPI (L98) SYSTEMS AND KITS**

Year	Part Number	Description	Boost Options	HP Gain	Intercooler	Price/MAP
1987*-92	1GC211-091	<a href="#">High Output Intercooled System with P-1SC</a>	9 psi	65%	2 core	\$5,999
1987*-92	1GC201-SCI	<a href="#">High Output Intercooled Tuner Kit with P-1SC</a>	specify	specify	2 core	\$5,749
1987*-92	1GC201-D1SC	<a href="#">Stage II Intercooled Tuner Kit with D-1SC</a>	specify	specify	3 core	\$6,499

<b>1987-92 CAMARO, FIREBIRD (L98) OPTIONS</b>	add "-B" or "-P" to part #	Black or Polished finish for ProCharger (P-series or D-series)	satin standard	-	-	+\$325
	add "-H" to part #	Helical gearset for noise reduction (P-1SC, D-1SC)	same	same	-	+\$110
	add "-D1SC" to part #	With D-1SC ProCharger (replacing P-1SC)	specify	specify	-	+\$495
	add "-3C" to part #	3 core intercooler upgrade	from 2 core	-	825 hp max	+\$435
	add "-OF" to part #	Omit FMU (Stage II)	-	-	-	-\$88
	add "-OP" to part #	Omit in-line fuel pump (Stage II)	-	-	-	-\$98

\* 1987 model years require Serpentine Accessory Belt Drive System, GM Part #12497698



# SPECIFICATIONS (1987-02 F-BODY)

## 1998-02 CAMARO/FIREBIRD (LS1) SPECIFICATIONS

Year	Part Number	OEM hp Rating	HP Gain	Tube Diam	IC Mount	Drive System	Bypass System	Fuel System Upgrade	Fuel Inj. Supplied	Computer/Ignition Modifications	Supercharger Warranty (in months)	CARB E.O.	Foot Notes
1999-02	1GJ214-SCI	310-325	40-55%	2.5" ea	H	add'l 6 rib	ProFlow	ProPump	38 lb/hr	programmer sup.	12, 36 opt. (\$99)	D-365-6	P1, P9, P10, P11
1998-02	1GJ213-SCI	310-325	specify	2.5" ea	H	add'l 6 rib	ProFlow	not supplied	No	not supplied	12	-	P1, P9, P10, P11, P14
1998-02	1GJ204-SCI	310-325	specify	2.5" ea	H	add'l 8 rib	ProFlow	not supplied	No	not supplied	12	-	P1, P9, P10, P11, P13, P14, P17

## 1993-97 CAMARO/FIREBIRD (LT1) SPECIFICATIONS

Year	Part Number	OEM hp Rating	HP Gain	Tube Diam	IC Mount	Drive System	Bypass System	Fuel System Upgrade	Fuel Inj. Supplied	Computer/Ignition Modifications	Supercharger Warranty (in months)	CARB E.O.	Foot Notes
1993-97	1GA211-07I/-09I	275-305	55-60%	3"	H	add'l 8 rib	ProFlow	ProPump	not required	not required	12, 36 opt. (\$99)	D-365-3 (93-95)	P1, P2, P3, P4, P5, P16
1993-97	1GA201-SCI	275-305	specify	3"	H	add'l 8 rib	ProFlow	not supplied	not required	not required	12	-	P1, P2, P3, P4, P5, P16
1993-97	1GA212-D1SC	275-305	specify	3.5" ea	H	add'l 12 rib	ProFlow	not supplied	No	not supplied	12	-	P1, P2, P3, P5, P6, P8, P14, P16

## 1987-92 CAMARO/FIREBIRD TPI (L98) SPECIFICATIONS

Year	Part Number	OEM hp Rating	HP Gain	Tube Diam	IC Mount	Drive System	Bypass System	Fuel System Upgrade	Fuel Inj. Supplied	Computer/Ignition Modifications	Supercharger Warranty (in months)	CARB E.O.	Foot Notes
1987-92	1GC211-09I	230-245	65%	3"	H	add'l 8 rib	ProFlow	ProPump	No	not required	12, 36 opt. (\$99) for 9 psi	D-365-3 (88-92)	P1, P12, P16
1987-92	1GC201-SCI	230-245	specify	3"	H	add'l 8 rib	ProFlow	not supplied	No	not required	12	-	P1, P12, P16
1987-92	1GC201-D1SC	230-245	specify	3"	H	add'l 8 rib	ProFlow	not supplied	No	not required	12	-	P1, P12, P16

## CHEVROLET/PONTIAC AUTOMOTIVE FOOTNOTES (specific to above applications):

- P1) Model year must be specified
- P2) Mass airflow massager required for '96-97 LT1's (sold separately by ProCharger)
- P3) LT1 F-bodies with traction control will require custom relocation of that module
- P4) 1993 LT1 F-bodies require the purchase of larger fuel injectors or an ignition retard system (sold separately by others)
- P5) May not accommodate all aftermarket balancers
- P6) Modified engines only
- P8) D-1SC, F-1, F-1A modified engines only (air inlet may require modification)
- P9) Pinning the balancer to the crank is recommended; Pin kit for stock balancer not supplied
- P10) Purchase of specific aftermarket harmonic balancer required for 8 rib and 10 rib upgrade, modifications required (ATI PP part #918853) (not included - specify hardened hub)
- P11) Crank pinning is recommended for higher horsepower applications
- P12) 1987 model years require Serpentine Accessory Belt Drive System, GM Part # 12497698
- P13) Race intercooler upgrade requires front bumper modification and requires system to ship in extra large box
- P14) F-series head unit upgrades may require minor modifications
- P16) Special order kit: order form and non-refundable deposit required at time of order—may require additional lead time for processing
- P17) Sway bar spacing may be required



**2014-17 CHEVROLET SS SYSTEMS AND KITS**

Year	Part Number	Description	Boost Options	HP Gain	Intercooler	Price/MAP
2014-17	1GW212-SCI	High Output Intercooled System with P-1SC-1	8 psi	50%	2 Core	\$8,599
2014-17	1GW202-SCI	High Output Intercooled Tuner Kit with P-1SC-1	specify	specify	2 Core	\$7,949

<b>2014-17 CHEVROLET SS</b>	add "-B" or "-P" to part #	Black or Polished finish for ProCharger (P-series or D-series )	satin standard	-	-	+\$325
	add "-B" or "-P" to part #	Black or Polished finish for ProCharger (F-series, 9" or 9.75" housing)	satin standard	-	-	+\$350
	add "-BB" or "-PB" to part #	Black or Polished finish for supercharger bracket	satin standard	-	-	+\$275
	add "-H" to part #	Helical gearset for noise reduction (P-1SC-1, P-1X, D-1SC, D-1X)	same	same	-	+\$110
	add "-P1X" to part #	With P-1X ProCharger (replacing P-1SC-1, Systems and Tuner Kits)	same	add'l 10-15+ hp	-	+\$250
	add "-D1SC" to part #	With D-1SC ProCharger (replacing P-1SC-1)	tuner kit only	specify	-	+\$275
	add "-D1X" to part #	With D-1X ProCharger (replacing P-1SC-1, Tuner Kits only)	tuner kit only	specify	-	+\$475
	add "-D" or "-1" or "-A"	With F-1D, F-1, F-1A ProCharger (replacing P-1SC-1)	tuner kit only	specify	-	+\$875
	add "-94" to part #	With F-1A-94 ProCharger (replacing P-1SC-1)	tuner kit only	specify	-	+\$1,225
	add "-RVR" or "RVB"	Race Bypass Valve Upgrade from ProFlow (Open only)	red or black	specify	-	+\$295
add "-3C" to part #	3 core intercooler system upgrade	from 2 core	825 hp max	3" tubing	+\$435	

**2008-09 PONTIAC G8 GT SYSTEMS AND KITS**

Year	Part Number	Description	Boost Options	HP Gain	Intercooler	Price/MAP
2008-09	1GS212-SCI	High Output Intercooled System with P-1SC-1	8 psi	50-55%	2 Core	\$8,399
2008-09	1GS202-SCI	High Output Intercooled Tuner Kit with P-1SC-1	specify	specify	2 Core	\$7,749

<b>2008-09 G8 GT OPTIONS</b>	add "-B" or "-P" to part #	Black or Polished finish for ProCharger (P-series or D-series )	satin standard	-	-	+\$325
	add "-B" or "-P" to part #	Black or Polished finish for ProCharger (F-series, 9" or 9.75" housing)	satin standard	-	-	+\$350
	add "-BB" or "-PB" to part #	Black or Polished finish for supercharger bracket	satin standard	-	-	+\$275
	add "-3C" to part #	3 core intercooler system upgrade	from 2 core	825 hp max	3" tubing	+\$435
	add "-H" to part #	Helical gearset for noise reduction (P-1SC-1, D-1SC)	same	same	-	+\$110
	add "-D1SC" to part #	With D-1SC ProCharger (replacing P-1SC-1)	tuner kit only	specify	-	+\$275
	add "-D" or "-1" or "-A"	With F-1D, F-1, F-1A ProCharger (replacing P-1SC-1)	tuner kit only	specify	-	+\$875
	add "-RVR" or "RVB"	Race Bypass Valve Upgrade from ProFlow (Open only)	red or black	specify	-	+\$295

**2004-06 PONTIAC GTO (LS1, LS2) SYSTEMS AND KITS**

Year	Part Number	Description	Boost Options	HP Gain	Intercooler	Price/MAP
2005-06 (LS2)	1GN312-SCI	High Output Intercooled System with P-1SC-1	7 psi	50%	GTO	\$8,699
2005-06 (LS2)	1GN302-SCI	High Output Intercooled Tuner Kit with P-1SC-1	specify	specify	GTO	\$7,799
2005-06 (LS2)	1GN313-F1A	Intercooled Serpentine Race Kit with F-1D, F-1, or F-1A	specify	specify	GTO	\$8,849
2004 (LS1)	1GN212-SCI	High Output Intercooled System with P-1SC-1	7 psi	50%	GTO	\$8,749
2004 (LS1)	1GN202-SCI	High Output Intercooled Tuner Kit with P-1SC-1	specify	specify	GTO	\$7,849
2004 (LS1)	1GN213-F1A	Intercooled Serpentine Race Kit with F-1D, F-1, or F-1A	specify	specify	GTO	\$8,849

<b>2004-06 GTO (LS1, LS2) OPTIONS</b>	add "-B" or "-P" to part #	Black or Polished finish for ProCharger (P-series or D-series)	satin standard	-	-	+\$325
	add "-B" or "-P" to part #	Black or Polished finish for ProCharger (F-series, 9" or 9.75" housing)	satin standard	-	-	+\$350
	add "-BB" or "-PB" to part #	Black or Polished finish for supercharger bracket	satin standard	-	-	+\$275
	add "-H" to part #	Helical gearset for noise reduction (P-1SC-1, D-1SC)	same	same	-	+\$110
	add "-D1SC" to part #	With D-1SC ProCharger (replacing P-1SC-1)	tuner kit only	specify	-	+\$275
	add "-RVR" or "RVB"	Race Bypass Valve Upgrade from ProFlow (specify open or closed valve)	red or black	specify	-	+\$295
	add "-3R" to part #	Race Intercooler Upgrade (1,000 hp, see Footnote Q8)	-	specify	-	+\$750
	add "-ATIPP" to part #	ATI Performance Products Balancer (#918853, 8 rib)	-	-	-	+\$525

# SPECIFICATIONS (2004-17 SS, G8, GTO)

## 2014-17 CHEVROLET SS SPECIFICATIONS

Year	Part Number	OEM hp Rating	HP Gain	Tube Diam	Intercooler Mount	Drive System	Bypass System	Fuel System Upgrade	Fuel Inj. Supplied	Computer/Ignition Modifications	Supercharger Warranty (in months)	CARB E.O.	Foot Notes
2014-17	1GW212-SCI	415	50%	3"	V	add'l 8 rib	ProFlow	not required	50 lb/hr	programmer sup.	12, 36 opt. (\$99)	-	Q1, Q2, Q3
2014-17	1GW202-SCI	415	specify	3"	V	add'l 8 rib	ProFlow	not supplied	no	not supplied	12	-	Q1, Q2

## 2008-09 PONTIAC G8 GT SPECIFICATIONS

Year	Part Number	OEM hp Rating	HP Gain	Tube Diam	Intercooler Mount	Drive System	Bypass System	Fuel System Upgrade	Fuel Inj. Supplied	Computer/Ignition Modifications	Supercharger Warranty (in months)	CARB E.O.	Foot Notes
2008-09	1GS212-SCI	361	50-55%	3"	V	add'l 8 rib	ProFlow	not required	50 lb/hr	programmer sup.	12, 36 opt. (\$99)	-	Q1, Q2, Q3, Q7, Q9, Q11
2008-09	1GS202-SCI	361	specify	3"	V	add'l 8 rib	ProFlow	not supplied	no	not supplied	12	-	Q1, Q2, Q7, Q9, Q12

## 2004-2006 PONTIAC GTO (LS1, LS2) SPECIFICATIONS

Year	Part Number	OEM hp Rating	HP Gain	Tube Diam	Intercooler Mount	Drive System	Bypass System	Fuel System Upgrade	Fuel Inj. Supplied	Computer/Ignition Modifications	Supercharger Warranty (in months)	CARB E.O.	Foot Notes
2005-06	1GN312-SCI	400	50%	3"	V	add'l 8 rib	ProFlow	not required	57 lb/hr	programmer sup.	12, 36 opt. (\$99)	-	Q1, Q2, Q3, Q4, Q5, Q6, Q8
2005-06	1GN302-SCI	400	specify	3"	V	add'l 8 rib	ProFlow	not supplied	No	not supplied	12	-	Q1, Q2, Q4, Q5, Q6, Q8
2005-06	1GN313-F1A	-	specify	3"	V	add'l 8 rib	Race	not supplied	No	not supplied	12	-	Q1, Q2, Q4, Q5, Q6, Q8, Q10
2004	1GN212-SCI	350	50%	3"	V	add'l 8 rib	ProFlow	not required	38 lb/hr	programmer sup.	12, 36 opt. (\$99)	D-365-6	Q1, Q2, Q4, Q5, Q6, Q8
2004	1GN202-SCI	350	specify	3"	V	add'l 8 rib	ProFlow	not supplied	No	not supplied	12	-	Q1, Q2, Q4, Q5, Q6, Q8
2004	1GN213-F1A	-	specify	3"	V	add'l 8 rib	Race	not supplied	No	not supplied	12	-	Q1, Q2, Q4, Q5, Q6, Q8, Q10

## CHEVROLET/PONTIAC AUTOMOTIVE FOOTNOTES (specific to above applications):

- Q1) Model year must be specified
- Q2) Pinning the balancer to the crank is recommended; Pin kit for stock balancer is supplied
- Q3) Due to variability among OEM computers, the prevalence of custom modifications, and age/miles/condition of vehicles, dyno tuning may be required
- Q4) Specify stock or aftermarket balancer, and stock or overdrive diameter crank pulley (if aftermarket balancer, requires ATI PP part #918853, not included - specify hardened hub)
- Q5) May require transmission cooling line modification
- Q6) System ships in extra large box
- Q7) 2009 G8 requires GM balancer part # 12674582
- Q8) Requires modification of front bumper (GTO race intercooler only)
- Q9) Requires modifications for 3 core upgrade
- Q10) Race intercooler recommended above 600 HP
- Q11) Complete systems are compatible with G8 GT models only
- Q12) Tuner Kits are compatible with G8 GT models, and GXP models with modifications



**\*NEW\* LS SERPENTINE ACCESSORY DRIVE KIT (PROCHARGER OPTIONAL)**

Year	Part Number	Description	Boost Options	HP Gain	Intercooler	Price/MAP
specify	1LS300	Serpentine Accessory Drive (with crank pulley + alternator bracket + water pump)	-	-	-	\$2,299
specify	1LS400	with ProCharger bracket, tensioner and 8 rib belt	-	-	-	\$2,949
specify	1LS300-PS	Serpentine Accessory Drive (with crank pulley + water pump + alternator bracket & p/s bracket)	-	-	-	\$2,599
specify	1LS400-PS	with ProCharger bracket, tensioner and 8 rib belt	-	-	-	\$3,249
specify	1LS300-AC	Serpentine Accessory Drive (with crank pulley + water pump + alternator bracket & a/c bracket)	-	-	-	\$2,499
specify	1LS400-AC	with ProCharger bracket, tensioner and 8 rib belt	-	-	-	\$3,149
specify	1LS300-PS-AC	Serpentine Accessory Drive (with crank pulley + water pump + alternator bracket, p/s bracket & a/c bracket)	-	-	-	\$2,799
specify	1LS400-PS-AC	with ProCharger bracket, tensioner and 8 rib belt	-	-	-	\$3,449
specify	1LS400-P1SC	Serpentine Accessory Drive Kit with P-1SC-1 (with water pump and all accessory brackets)	specify	specify	-	\$5,899
specify	1LS400-P1SC-I	Serpentine Accessory Drive Kit with Intercooled P-1SC-1 (with water pump and all acc brackets)	specify	specify	2 core (550 hp)	\$6,799
specify	1LS400-P1X	Serpentine Accessory Drive Kit with P-1X (with water pump and all accessory brackets)	specify	specify	-	\$6,149
specify	1LS400-P1X-I	Serpentine Accessory Drive Kit with Intercooled P-1X (with water pump and all accessory brackets)	specify	specify	2 core (550 hp)	\$7,049
specify	1LS400-D1SC	Serpentine Accessory Drive Kit with D-1SC (with water pump and all accessory brackets)	specify	specify	-	\$6,199
specify	1LS400-D1SC-I	Serpentine Accessory Drive Kit with Intercooled D-1SC (with water pump and all accessory brackets)	specify	specify	3 core (825 hp)	\$7,499
specify	1LS400-D1X	Serpentine Accessory Drive Kit with D-1X (with water pump and all accessory brackets)	specify	specify	-	\$6,399
specify	1LS400-D1X-I	Serpentine Accessory Drive Kit with Intercooled D-1X (with water pump and all acc brackets)	specify	specify	3 core (825 hp)	\$7,599
specify	1LS400-F1D/F1/F1A	Serpentine Accessory Drive Kit with F-1D, F-1, or F-1A (with water pump and all accessory brackets)	specify	specify	-	\$7,349
specify	1LS400-F1D-I/F1-I/F1A-I	Serpentine Accessory Drive Kit with Intercooled F-1D, F-1, or F-1A (with w/p and all acc brackets)	specify	specify	Sht mtl 3C (950 hp)	\$8,749
specify	1LS400-F1A94/F1C/F1R	Serpentine Accessory Drive Kit with F-1A-94, F-1C or F-1R (with water pump and all accessory brackets)	specify	specify	-	\$7,749
specify	1LS400-F1A94-I/F1C-I/F1R-I	Serpentine Accessory Drive Kit with Intercooled F-1A-94, F-1C or F-1R (w/p and all acc brackets)	specify	specify	Sht mtl 3C (1050 hp)	\$9,349
specify	1LS400-F1X	Serpentine Accessory Drive Kit with F-1X (10 rib) (with water pump and all accessory brackets)	specify	specify	-	\$9,399
specify	1LS400-F1X-I	Serpentine Accessory Drive Kit with Intercooled F-1X (10 rib) with w/p and all acc brackets)	specify	specify	Sht mtl 3C (1300 hp)	\$10,899
specify	1LS400-F2	Serpentine Accessory Drive Kit with F-2 (10 rib) (with water pump and all accessory brackets)	specify	specify	-	\$9,599
specify	1LS400-F2-I	Serpentine Accessory Drive Kit with Intercooled F-2 (10 rib) (with w/p and all acc brackets)	specify	specify	Sht mtl 3C (1300 hp)	\$11,099

LS Serpentine Accessory Drive Kit Options	add "-B" or "-P" to part #	Black or Polished finish for ProCharger (P-series or D-series)	satin standard	-	-	+\$325
	add "-B" or "-P" to part #	Black or Polished finish for ProCharger (F-series 9"-9.75" housing)	satin standard	-	-	+\$375
	add "-B" or "-P" to part #	Black or Polished finish for ProCharger (F-series, 10.5" housing)	satin standard	-	-	+\$425
	add "-BAC" or "PAC"	Black or Polished finish for air conditioning bracket	satin standard	-	-	+\$75
	add "-BPB" or "-PPB"	Black or Polished finish for power steering bracket	satin standard	-	-	+\$75
	add "-BB" or "-PB" to part #	Black or Polished finish for supercharger bracket, water pump, alternator bracket, and tensioner	satin standard	-	-	+\$450
	add "-BC" or "-PC" to part #	Black or Polished finish for carburetor bonnet	satin standard	-	-	+\$100
	add "-H" to part #	Helical gearset for noise reduction (P-1SC-1, P-1X, D-1SC, D-1X)	same	same	-	+\$110
	add "-OPB"	Omit power steering belt, bracket & pulley	-	-	-	-\$300
	add "-OAB"	Omit air conditioning bracket & pulley	-	-	-	-\$200
	3LSBB-006	Add ProCharger supercharger bracket 8 rib, tensioner & belt (included with 1LS400)	from 1LS300	-	-	+\$1,628
	3GKMM-004	Crank pin kit	-	-	-	+\$109
	add "-10R" to part #	10-Rib supercharger drive belt (from 8 rib)	from 8 rib	-	-	+\$375
	call	Add Black finish for water pump	satin standard	-	-	call
	call	Add Satin / Black / Chrome alternator	-	-	-	call
	call	Add Satin / Black / Chrome power steering pump	-	-	-	call
	call	Add Satin / Black / Chrome air conditioning compressor	-	-	-	call
	AI003A-001	3 core intercooler (825 hp)	from non-ic kit	3" in/outlet	-	+\$1,198
	AI003A-002	Sheet metal 3 core race intercooler (950 hp)	from non-ic kit	3" in/outlet	-	+\$1,398
	AI003A-005	Sheet metal 3 core race intercooler (1050 hp)	from non-ic kit	3.5" in/outlet	-	+\$1,498
AI045A-001	Sheet metal 3 core race intercooler (1300 hp)	from non-ic kit	3.5" in/outlet	-	+\$1,798	
AI006A-001	Sheet metal 3 core race intercooler (1550 hp)	from non-ic kit	4" in/outlet	-	+\$2,298	
AM006A-001	Low Profile carburetor bonnet (3" inlet, 2" height)	-	-	-	+\$180	
AM009A-001	Standard carburetor bonnet (3.5" inlet, 2.75" height)	-	-	-	+\$199	
AM001A-001	Competition carburetor bonnet (3.5" inlet, 4.15" height)	-	-	-	+\$240	



FOR MORE INFORMATION:  
 SCAN CODE WITH PHONE OR VISIT:  
**PROCHARGER.COM/LS-SERPENTINE-ACCESSORY-DRIVE-KIT**



# SPECIFICATIONS (LS SERPENTINE ACCESSORY DRIVE KIT)

## \*NEW\* LS SERPENTINE ACCESSORY DRIVE KIT SPECIFICATIONS

Year	Part Number	Stock HP	HP Gain	Tube Diam	Carb Hat	Drive System	Bypass Valve	Water Pump	Alternator Bracket	Power Steering Bracket	Air Cond. Bracket	Supercharger Warranty (in months)	Tubing Supplied	Foot Notes
specify	1LS300	N/A	specify	-	optional	6 rib Acc Drive	-	included	included	-	-	12	-	all
specify	1LS400	N/A	specify	-	optional	6 rib / 8 rib	-	included	included	-	-	12	-	all
specify	1LS300-PS	N/A	specify	-	optional	6 rib Acc Drive	-	included	included	included	-	12	-	all
specify	1LS400-PS	N/A	specify	-	optional	6 rib / 8 rib	-	included	included	included	-	12	-	all
specify	1LS300-AC	N/A	specify	-	optional	6 rib Acc Drive	-	included	included	-	included	12	-	all
specify	1LS400-AC	N/A	specify	-	optional	6 rib / 8 rib	-	included	included	-	included	12	-	all
specify	1LS300-PS-AC	N/A	specify	-	optional	6 rib Acc Drive	-	included	included	included	included	12	-	all
specify	1LS400-PS-AC	N/A	specify	-	optional	6 rib / 8 rib	-	included	included	included	included	12	-	all
specify	1LS400-P1SC1	N/A	specify	-	optional	6 rib / 8 rib	ProFlow	included	included	included	included	12	-	all
specify	1LS400-P1SC1-I	N/A	specify	3"	optional	6 rib / 8 rib	ProFlow	included	included	included	included	12	yes	all
specify	1LS400-P1X	N/A	specify	-	optional	6 rib / 8 rib	ProFlow	included	included	included	included	12	-	all
specify	1LS400-P1X-I	N/A	specify	3"	optional	6 rib / 8 rib	ProFlow	included	included	included	included	12	yes	all
specify	1LS400-D1SC	N/A	specify	-	optional	6 rib / 8 rib	ProFlow	included	included	included	included	12	-	all
specify	1LS400-D1SC-I	N/A	specify	3"	optional	6 rib / 8 rib	ProFlow	included	included	included	included	12	yes	all
specify	1LS400-D1X	N/A	specify	-	optional	6 rib / 8 rib	ProFlow	included	included	included	included	12	-	all
specify	1LS400-D1X-I	N/A	specify	3"	optional	6 rib / 8 rib	ProFlow	included	included	included	included	12	yes	all
specify	1LS400-F1D/F1/F1A	N/A	specify	-	optional	6 rib / 8 rib	Race Valve	included	included	included	included	12	-	all
specify	1LS400-F1D-I/F1-I/F1A-I	N/A	specify	3"	optional	6 rib / 8 rib	Race Valve	included	included	included	included	12	yes	all
specify	1LS400-F1A94/F1C/F1R	N/A	specify	-	optional	6 rib / 8 rib	Race Valve	included	included	included	included	12	-	all
specify	1LS400-F1A94-I/F1C-I/F1R-I	N/A	specify	3.5"	optional	6 rib / 8 rib	Race Valve	included	included	included	included	12	yes	all
specify	1LS400-F1X	N/A	specify	-	optional	6 rib / 10 rib	Race Valve	included	included	included	included	12	-	all
specify	1LS400-F1X-I	N/A	specify	3.5"	optional	6 rib / 10 rib	Race Valve	included	included	included	included	12	yes	all
specify	1LS400-F2	N/A	specify	-	optional	6 rib / 10 rib	Race Valve	included	included	included	included	12	-	all
specify	1LS400-F2-I	N/A	specify	3.5"	optional	6 rib / 10 rib	Race Valve	included	included	included	included	12	yes	all



FOR MORE INFORMATION:  
SCAN CODE WITH PHONE OR VISIT:  
[PROCHARGER.COM/LS-SERPENTINE-ACCESSORY-DRIVE-KIT](http://PROCHARGER.COM/LS-SERPENTINE-ACCESSORY-DRIVE-KIT)

### LS ENGINE SWAP FOOTNOTES (specific to above applications):

- LL1) Requires Innovators West P/N 844-10-rib or 843-8-rib, or ATI Performance Products Balancer p/n 917345 (8-rib) and p/n 917347X (10-rib)
- LL2) Pinning crank pulley is recommended
- LL3) Can be ordered without a/c.
- LL4) Can be ordered without power steering
- LL5) Not available for LS7
- LL6) Not tall deck compatible
- LL7) Not compatible with VVT

### COMPATIBLE GM ACCESSORIES

Description	Part #	Manufacturer/Notes
Power Steering Pump	6175AL	Tuff Stuff (or equivalent), GM Type 2
Alternator	20881337	GM, 2007-2013
A/C Compressor	SD-7B10	Sanden, 6-rib
Reservoir	6175ARES	Required
Water Pump (supplied)		



CONTACT US AT (913) 338-2886 OR LEARN MORE AT [PROCHARGER.COM](http://PROCHARGER.COM)

## LS ENGINE SWAP SERPENTINE KITS (EFI AND CARBURETED)

Year	Part Number	Description	Boost Options	HP Gain	Intercooler	Price/MAP
specify	1LS100-P1SC1	High Output with P-1SC-1	specify	specify	-	\$4,999
specify	1LS100-P1SC1-I	<b>High Output with Intercooled P-1SC-1</b>	specify	specify	2 core (550 hp)	\$5,949
specify	1LS100-P1X	High Output with P-1X	specify	specify	-	\$5,249
specify	1LS100-P1X-I	<b>High Output with Intercooled P-1X</b>	specify	specify	2 core (550 hp)	\$6,149
specify	1LS100-D1SC	High Output with D-1SC	specify	specify	-	\$5,399
specify	1LS100-D1SC-I	<b>High Output with Intercooled D-1SC</b>	specify	specify	3 core (825 hp)	\$6,699
specify	1LS100-D1X	High Output with D-1X	specify	specify	-	\$5,649
specify	1LS100-D1X-I	<b>High Output with Intercooled D-1X</b>	specify	specify	3 core (825 hp)	\$6,849
specify	1LS100-F1D/F1/F1A	High Output with F-1D, F-1, or F-1A	specify	specify	-	\$6,649
specify	1LS100-F1D-I/F1-I/F1A-I	<b>High Output with Intercooled F-1D, F-1, or F-1A</b>	specify	specify	Sht mtl 3C (950 hp)	\$7,999
specify	1LS100-F1A94/F1C/F1R	High Output with F-1A-94, F-1C or F-1R	specify	specify	-	\$6,999
specify	1LS100-F1A94-I/F1C-I/F1R-I	<b>High Output with Intercooled F-1A-94, F-1C or F-1R</b>	specify	specify	Sht mtl 3C (1050 hp)	\$8,499

## LS ENGINE SWAP COG RACE KITS (EFI AND CARBURETED)

Year	Part Number	Description	Boost Options	HP Gain	Intercooler	Price/MAP
specify	1LS200-F1D/F1/F1A	Cog Kit with F-1D, F-1, or F-1A	specify	specify	-	\$6,899
specify	1LS200-F1D-I/F1-I/F1A-I	<b>Cog Kit with Intercooled F-1D, F-1, or F-1A</b>	specify	specify	Sht mtl 3C (950 hp)	\$8,299
specify	1LS200-F1A94/F1C/F1R	Cog Kit with F-1A-94, F-1C or F-1R	specify	specify	-	\$7,299
specify	1LS200-F1A94-I/F1C-I/F1R-I	<b>Cog Kit with Intercooled F-1A-94, F-1C or F-1R</b>	specify	specify	Sht mtl 3C (1050 hp)	\$8,849
specify	1LS200-F1X	Cog Kit with F-1X	specify	specify	-	\$8,549
specify	1LS200-F1X-I	<b>Cog Kit with Intercooled F-1X</b>	specify	specify	Sht mtl 3C (1300 hp)	\$10,099
specify	1LS200-F2	Cog Kit with F-2	specify	specify	-	\$8,749
specify	1LS200-F2-I	<b>Cog Kit with Intercooled F-2</b>	specify	specify	Sht mtl 3C (1300 hp)	\$10,299

LS ENGINE SWAP KIT OPTIONS	add "-B" or "-P" to part #	Black or Polished finish for ProCharger (P-series or D-series)	satn standard	-	-	+\$325
	add "-B" or "-P" to part #	Black or Polished finish for ProCharger (F-series 9"-9.75" housing)	satn standard	-	-	+\$350
	add "-B" or "-P" to part #	Black or Polished finish for ProCharger (F-series, 10.5" housing)	satn standard	-	-	+\$375
	add "-BB" or "-PB" to part #	Black or Polished finish for main bracket and tensioner	satn standard	-	-	+\$275
	add "-BC" or "-PC" to part #	Black or Polished finish for carburetor bonnet	satn standard	-	-	+\$100
	add "-BAB" or "PAB"	Black or Polished finish for alternator bracket	satn standard	-	-	+\$170
	add "-BPB" or "-PPB"	Black or Polished finish for power steering bracket	satn standard	-	-	+\$175
	add "-H" to part #	Helical gearset for noise reduction (P-1SC-1, P-1X, D-1SC, D-1X)	same	same	-	+\$110
	AM006A-001	Low Profile Carburetor Bonnet (3" inlet, 2" height)	-	-	-	+\$220
	AM009A-001	Standard Carburetor Bonnet (3.5" inlet, 2.75" height)	-	-	-	+\$242
	AM001A-001	Competition Carburetor Bonnet (3.5" inlet, 4.15" height)	-	-	-	+\$292
	specify	Non-intercooled Carburetor Tubing Kit (3" or 3.5")	-	-	-	specify
	add "-12R" to part #	12-Rib Drive System Upgrade (from 8 rib, serpentine kits only)	from 8 rib	-	-	+\$260
	add "-ATIPP" to part #	ATI Performance Products Balancer (#918853)	-	-	-	+\$525
	3GKMM-004	Crank Pin Kit	-	-	-	+\$109
	3LSAT-002	Alternator bracket with tensioner	-	-	-	+\$570
	3LSPS-001	Power steering bracket (requires GM pump, #21997867)	-	-	-	+\$255
	3LSPS-002	Power steering delete bracket	-	-	-	+\$225
	3CASS-002	ProFlow Bypass Valve Kit	-	-	-	+\$268
	AV006A-00X	Bullet Bypass/Anti-Surge Valve, (open or closed)	from ProFlow	-	-	+\$125
	3FASS-00X	Race Bypass Valve Open or Cosed (specify alum. or steel flange - Red or Black)	from ProFlow	-	-	\$295
	AI003A-001	3 core intercooler (825 hp)	from non-ic kit	3" in/outlet	-	+\$1,198
AI003A-002	Sheet metal 3 core race intercooler (950 hp)	from non-ic kit	3" in/outlet	-	+\$1,398	
AI003A-005	Sheet metal 3 core race intercooler (1050 hp)	from non-ic kit	3.5" in/outlet	-	+\$1,498	
AI045A-001	Sheet metal 3 core race intercooler (1300 hp)	from non-ic kit	3.5" in/outlet	-	+\$1,798	
AI006A-001	Sheet metal 3 core race intercooler (1550 hp)	from non-ic kit	4" in/outlet	-	+\$2,298	
FP001I-006	High Performance 1000 hp electric fuel pump	-	-	-	+\$438	

FOR LS SERPENTINE ACCESSORY DRIVE KIT, SEE PAGE 42

FOR CRANKDRIVE AND RACEDRIVE DETAILS, VISIT PROCHARGER.COM

# SPECIFICATIONS (LS ENGINE SWAP)

## LS ENGINE SWAP SERPENTINE SPECIFICATIONS

Year	Part Number	Stock HP	HP Gain	Tube Diam	Carb Hat	Drive System	Bypass Valve	Power Steering Bracket (optional)	Alternator Bracket (optional)	SC Warranty (in months)	Tubing Supplied	Foot Notes
specify	1LS100-P1SC1	N/A	specify	-	optional	8 rib	ProFlow	yes	yes	12	-	all
specify	1LS100-P1SC1-I	N/A	specify	3"	optional	8 rib	ProFlow	yes	yes	12	yes	all
specify	1LS100-P1X	N/A	specify	-	optional	8 rib	ProFlow	yes	yes	12	-	all
specify	1LS100-P1X-I	N/A	specify	3"	optional	8 rib	ProFlow	yes	yes	12	yes	all
specify	1LS100-D1SC	N/A	specify	-	optional	8 rib	ProFlow	yes	yes	12	-	all
specify	1LS100-D1SC-I	N/A	specify	3"	optional	8 rib	ProFlow	yes	yes	12	yes	all
specify	1LS100-D1X	N/A	specify	-	optional	8 rib	ProFlow	yes	yes	12	-	all
specify	1LS100-D1X-I	N/A	specify	3"	optional	8 rib	ProFlow	yes	yes	12	yes	all
specify	1LS100-F1D/F1/F1A	N/A	specify	-	optional	8 rib	Race Valve	yes	yes	12	-	all
specify	1LS100-F1D-I/F1-I/F1A-I	N/A	specify	3"	optional	8 rib	Race Valve	yes	yes	12	yes	all
specify	1LS100-F1A94/F1C/F1R	N/A	specify	-	optional	8 rib	Race Valve	yes	yes	12	-	all
specify	1LS100-F1A94-I/F1C-I/F1R-I	N/A	specify	3.5"	optional	8 rib	Race Valve	yes	yes	12	yes	all

## LS ENGINE SWAP COG RACE SPECIFICATIONS

Year	Part Number	Stock HP	HP Gain	Tube Diam	Carb Hat	Drive System	Bypass Valve	Power Steering Bracket (optional)	Alternator Bracket (optional)	SC Warranty (in months)	Tubing Supplied	Foot Notes
specify	1LS200-F1D/F1/F1A	N/A	specify	-	optional	8 x 50 mm cog	Race Valve	yes	yes	Limited	-	all
specify	1LS200-F1D-I/F1-I/F1A-I	N/A	specify	3"	optional	8 x 50 mm cog	Race Valve	yes	yes	Limited	yes	all
specify	1LS200-F1A94/F1C/F1R	N/A	specify	-	optional	8 x 50 mm cog	Race Valve	yes	yes	Limited	-	all
specify	1LS200-F1A94-I/F1C-I/F1R-I	N/A	specify	3.5"	optional	8 x 50 mm cog	Race Valve	yes	yes	Limited	yes	all
specify	1LS200-F1X	N/A	specify	-	optional	8 x 50 mm cog	Race Valve	yes	yes	Limited	-	all
specify	1LS200-F1X-I	N/A	specify	3.5"	optional	8 x 50 mm cog	Race Valve	yes	yes	Limited	yes	all
specify	1LS200-F2	N/A	specify	-	optional	8 x 50 mm cog	Race Valve	yes	yes	Limited	-	all
specify	1LS200-F2-I	N/A	specify	3.5"	optional	8 x 50 mm cog	Race Valve	yes	yes	Limited	yes	all

## COMPATIBLE GM ACCESSORIES

Description	GM Part #	OEM Vehicle Source
Power Steering Pump	21997867	2004-2007 Cadillac CTS
Power Steering Pulley	12568997	2004-2007 Cadillac CTS
Alternator	19244751	1999-2013 GM Truck 4.8/5.3/6.0
A/C Compressor	92175482	1998-2002 LS1 F-Body
A/C Bracket	92066950	1998-2002 LS1 F-Body
A/C Belt	25-040430	Napa
A/C Belt Tensioner	12595289	---
Water Pump	89017593	1998-2002 LS1 F-Body

(Auto part stores can use these to cross reference other compatible brands)

## LS ENGINE SWAP FOOTNOTES (specific to above applications):

- T1) Requires ATI Performance Products balancer (LS3/LS2/LS1 part #918853, LS7 part #918620) (not supplied - specify hardened hub)
- T2) Specify with or without power steering when using ProCharger Accessory Brackets
- T3) Pinning of the crank pulley is recommended
- T4) Compatible with mechanical or electric water pump
- T5) Designed to work with Muscle Rods motor mounts or comparable (application dependent, sold separately by others)
- T6) Not compatible with Corvette-style water pump
- T7) Specify iron block, aluminum block and tall deck
- T8) LS7 engine requires modifications (not supplied)
- T9) Not a direct bolt-on for VVT engines



CONTACT US AT (913) 338-2886 OR LEARN MORE AT PROCHARGER.COM

## LS REVERSE PASSENGER SIDE ENGINE SWAP KIT

Year	Part Number	Description	Boost Options	HP Gain	Intercooler	Price/MAP
specify	1GQ400-P1SC-1	High Output with P-1SC-1	specify	specify	-	\$4,999
specify	1GQ400-P1SC-1-I	<b>High Output with Intercooled P-1SC-1</b>	specify	specify	2 core (550hp)	\$5,899
specify	1GQ400-D1SC	High Output with D-1SC	specify	specify	-	\$5,299
specify	1GQ400-D1SC-I	<b>High Output with Intercooled D-1SC</b>	specify	specify	3 core (825hp)	\$6,699
specify	1GQ400-F1D/F1/F1A	High Output with F-1D, F-1, or F-1A	specify	specify	-	\$6,599
specify	1GQ400-F1D-I/F1-I/F1A-I	<b>High Output with Intercooled F-1D, F-1, or F-1A</b>	specify	specify	Sht mtl 3C (950hp)	\$7,999
specify	1GQ400-F1A94/F1C/F1R	High Output with F-1A-94, F-1C or F-1R	specify	specify	-	\$6,949
specify	1GQ400-F1A94-I/F1C-I/F1R-I	<b>High Output with Intercooled F-1A-94, F-1C or F-1R</b>	specify	specify	Sht mtl 3C (1050hp)	\$8,449
specify	1GQ400-F1X	High Output with F-1X	specify	specify	-	\$8,199
specify	1GQ400-F1X-I	<b>High Output with Intercooled F-1X</b>	specify	specify	Sht mtl 3C (1050hp)	\$9,699
specify	1GQ400-F2	High Output with F-2	specify	specify	-	\$8,399
specify	1GQ400-F2-I	<b>High Output with Intercooled F-2</b>	specify	specify	Sht mtl 3C (1050hp)	\$9,899

## LT1/LT4 ENGINE SWAP SERPENTINE KITS (2014+)

Year	Part Number	Description	Boost Options	HP Gain	Intercooler	Price/MAP
specify	1LT100-P1SC1	High Output with P-1SC-1	specify	specify	-	\$4,899
specify	1LT100-P1SC1-I	<b>High Output with Intercooled P-1SC-1</b>	specify	specify	2 core (550hp)	\$5,899
specify	1LT100-D1SC	High Output with D-1SC	specify	specify	-	\$5,149
specify	1LT100-D1SC-I	<b>High Output with Intercooled D-1SC</b>	specify	specify	3 core (825hp)	\$6,549
specify	1LT100-F1D/F1/F1A	High Output with F-1D, F-1, or F-1A	specify	specify	-	\$6,299
specify	1LT100-F1D-I/F1-I/F1A-I	<b>High Output with Intercooled F-1D, F-1, or F-1A</b>	specify	specify	Sht mtl 3C (950hp)	\$7,699
specify	1LT100-F1A94/F1C/F1R	High Output with F-1A-94, F-1C or F-1R	specify	specify	-	\$6,699
specify	1LT100-F1A94-I/F1C-I/F1R-I	<b>High Output with Intercooled F-1A-94, F-1C or F-1R</b>	specify	specify	Sht mtl 3C (1050hp)	\$8,199
specify	1LT100-F1X	High Output with F-1X	specify	specify	-	\$7,149
specify	1LT100-F1X-I	<b>High Output with Intercooled F-1X</b>	specify	specify	Sht mtl 3C (1050hp)	\$8,649
specify	1LT100-F2	High Output with F-2	specify	specify	-	\$7,349
specify	1LT100-F2-I	<b>High Output with Intercooled F-2</b>	specify	specify	Sht mtl 3C (1050hp)	\$8,849

LS PASS SIDE / LT1 / LT4 SERPENTINE ENGINE SWAP KIT OPTIONS	add "-B" or "-P" to part #	Black or Polished finish for ProCharger (P-series or D-series)	specify	specify	-	+\$325
	add "-B" or "-P" to part #	Black or Polished finish for ProCharger (F-series, 9" or 9.75" housing)	specify	specify	-	+\$350
	add "-B" or "-P" to part #	Black or Polished finish for ProCharger (F-series, 10.5" housing)	specify	specify	-	+\$375
	add "-BB" or "-PB" to part #	Black or Polished finish for main bracket and tensioner	specify	specify	-	+\$275
	add "-BPB" or "-PPB"	Black or Polished finish for power steering bracket	specify	specify	-	+\$175
	add "-10R" to part #	10 rib drive system upgrade (LS Only)	from 8 rib	specify	-	+\$360
	add "-H" to part #	Helical gerset for noise reduction (P-1SC-1, P-1X, D-1SC, D-1X)	specify	specify	-	+\$110
	add "-P1X" to part #	With P-1X ProCharger (replacing P-1SC-1)	-	add'l 10-15+ hp	-	+\$250
	add "-D1X" to part #	With D-1X ProCharger (replacing P-1SC-1)	-	specify	-	+\$475
	AI003A-001	3 core intercooler (825 hp)	from non-ic kit	3" in/outlet	-	+\$1,198
	AI003A-002	Sheet metal 3 core race intercooler (950 hp)	from non-ic kit	3" in/outlet	-	+\$1,398
	AI003A-005	Sheet metal 3 core race intercooler (1050 hp)	from non-ic kit	3.5" in/outlet	-	+\$1,498
	AI045A-001	Sheet metal 3 core race intercooler (1300 hp)	from non-ic kit	3.5" in/outlet	-	+\$1,798
	AI006A-001	Sheet metal 3 core race intercooler (1550 hp)	from non-ic kit	4" in/outlet	-	+\$2,298
add "-RV"	Race Bypass Valve, Open or Cosed (specify alum. or steel flange - Red or Black)	from ProFlow	-	-	+\$295	
LS ONLY	3GKMM-004	Crank Pin Kit	-	-	-	+\$109
LT1/LT4 ONLY	add "-ATIPP" to part #	ATI Performance Products Balancer Upgrade (ATIPP #917314) - LT1 Only	-	-	-	+\$525
	3LTPS-001	Power steering bracket (requires GM Type II pump) - LT1 only	-	-	-	+\$255
	add "-INT" to part #	Sheet Metal Alum Intake Manifold/Cover (replaces OEM manifold)	unfinished std	-	-	+\$2,498
	add "-INT/INJ" to part #	Sheet Metal Alum Intake Manifold/Cover w/ injector bungs, fuel rails	unfinished std	-	-	+\$2,998
	add "-BI" to part #	Black Finish for Sheet Metal Intake Manifold	unfinished std	-	-	+\$225
add "-BC" to part #	Black Finish for Sheet Metal Intake Manifold Cover	unfinished std	-	-	+\$35	



# SPECIFICATIONS (LS/LT1/LT4 ENGINE SWAP)

## LS REVERSE PASSENGER SIDE ENGINE SWAP KIT SPECIFICATIONS

Year	Part Number	Stock HP	HP Gain	Tube Diam	Carb Hat	Drive System	Bypass Valve	Power Steering Bracket (optional)	SC Warranty (in months)	Tubing Supplied	Foot Notes
specify	1GQ400-P1SC1	N/A	specify	-	optional	8 rib	ProFlow	yes	12	-	U5, U7, U8, U9, U10, U11, U12
specify	1GQ400-P1SC1-I	N/A	specify	3"	optional	8 rib	ProFlow	yes	12	yes	U5, U7, U8, U9, U10, U11, U12
specify	1GQ400-D1SC	N/A	specify	-	optional	8 rib	ProFlow	yes	12	-	U5, U7, U8, U9, U10, U11, U12
specify	1GQ400-D1SC-I	N/A	specify	3"	optional	8 rib	ProFlow	yes	12	yes	U5, U7, U8, U9, U10, U11, U12
specify	1GQ400-F1D/F1/F1A	N/A	specify	-	optional	8 rib	Race Valve	yes	12	-	U5, U7, U8, U9, U10, U11, U12
specify	1GQ400-F1D-I/F1-I/F1A-I	N/A	specify	3"	optional	8 rib	Race Valve	yes	12	yes	U5, U7, U8, U9, U10, U11, U12
specify	1GQ400-F1A94/F1C/F1R	N/A	specify	-	optional	8 rib	Race Valve	yes	12	-	U5, U7, U8, U9, U10, U11, U12
specify	1GQ400-F1A94-I/F1C-I/F1R-I	N/A	specify	3.5"	optional	8 rib	Race Valve	yes	12	yes	U5, U7, U8, U9, U10, U11, U12
specify	1GQ400-F1X	N/A	specify	-	optional	8 rib	Race Valve	yes	12	-	U5, U7, U8, U9, U10, U11, U12
specify	1GQ400-F1X-I	N/A	specify	3.5"	optional	8 rib	Race Valve	yes	12	yes	U5, U7, U8, U9, U10, U11, U12
specify	1GQ400-F2	N/A	specify	-	optional	8 rib	Race Valve	yes	12	-	U5, U7, U8, U9, U10, U11, U12
specify	1GQ100-F2-I	N/A	specify	3.5"	optional	8 rib	Race Valve	yes	12	yes	U5, U7, U8, U9, U10, U11, U12

## LT1/LT4 ENGINE SWAP SERPENTINE (2014+) SPECIFICATIONS

Year	Part Number	Stock HP	HP Gain	Tube Diam	Carb Hat	Drive System	Bypass Valve	Power Steering Bracket (optional)	SC Warranty (in months)	Tubing Supplied	Foot Notes
specify	1LT100-P1SC-1	N/A	specify	-	optional	8 rib	ProFlow	yes	12	-	U1, U2, U3, U4, U5, U6, U7
specify	1LT100-P1SC1-I	N/A	specify	3"	optional	8 rib	ProFlow	yes	12	yes	U1, U2, U3, U4, U5, U6, U7
specify	1LT100-D1SC	N/A	specify	-	optional	8 rib	ProFlow	yes	12	-	U1, U2, U3, U4, U5, U6, U7
specify	1LT100-D1SC-I	N/A	specify	3"	optional	8 rib	ProFlow	yes	12	yes	U1, U2, U3, U4, U5, U6, U7
specify	1LT100-F1D/F1/F1A	N/A	specify	-	optional	8 rib	Race Valve	yes	12	-	U1, U2, U3, U4, U5, U6, U7
specify	1LT100-F1D-I/F1-I/F1A-I	N/A	specify	3"	optional	8 rib	Race Valve	yes	12	yes	U1, U2, U3, U4, U5, U6, U7
specify	1LT100-F1A94/F1C/F1R	N/A	specify	-	optional	8 rib	Race Valve	yes	12	-	U1, U2, U3, U4, U5, U6, U7
specify	1LT100-F1A94-I/F1C-I/F1R-I	N/A	specify	3.5"	optional	8 rib	Race Valve	yes	12	yes	U1, U2, U3, U4, U5, U6, U7
specify	1LT100-F1X	N/A	specify	-	optional	8 rib	Race Valve	yes	12	-	U1, U2, U3, U4, U5, U6, U7
specify	1LT100-F1X-I	N/A	specify	3.5"	optional	8 rib	Race Valve	yes	12	yes	U1, U2, U3, U4, U5, U6, U7
specify	1LT100-F2	N/A	specify	-	optional	8 rib	Race Valve	yes	12	-	U1, U2, U3, U4, U5, U6, U7
specify	1LT100-F2-I	N/A	specify	3.5"	optional	8 rib	Race Valve	yes	12	yes	U1, U2, U3, U4, U5, U6, U7

## PASSENGER SIDE LS/LT1/LT4 ENGINE SWAP FOOTNOTES (specific to above applications):

- U1) Comes with ProCharger 8-rib crank pulley, but is also compatible with ATI PP Super Damper (Part# 917314)
- U2) Works with OEM LT1 intake and ProCharger LT1/LT4 Sheet Metal Aluminum Intake Manifold
- U3) Uses all factory LT1 (Corvette) accessories
- U4) Factory power steering pump can be used with an attached fluid reservoir, remote reservoir recommended
- U5) Compatible with factory and most aftermarket A/C compressors
- U6) Specify LT1 or LT4 engine model
- U7) Specify wet or dry oil sump
- U8) 8-rib drive requires ATI PP bal #917345 (LSx, wet sump) or #918620 (LS7 dry sump - not supplied), or Innovator's West bal #843 (LS, wet sump) or #853 (LS7 dry sump) (not included - specify hardened hub)
- U9) Optional 10-rib requires ATI PP bal #917347X (LS, wet sump) (not supplied), or Innovator's West balancer #844 (LSx, wet sump) or #854 (LS7 dry sump) (not included - specify hardened hub)
- U10) May require water pump modification (optional water pump available from ProCharger)
- U11) LS passenger side uses common C6 Corvette accessories
- U12) Iron block requires drilling and tapping



**\*NEW\* SBC/BBC SERPENTINE ACCESSORY DRIVE KIT (PROCHARGER OPTIONAL)**

Part Number SBC	Part Number BBC	Description	Boost Options	HP Gain	Intercooler	Price/MAP
1CA300	1CB300	Serpentine Accessory Drive (with crank pulley + alternator bracket)	-	-	-	\$2,199
1CA400	1CB400	with ProCharger bracket, tensioner and 8 rib belt	-	-	-	\$2,799
1CA300-PS	1CB300-PS	Serpentine Accessory Drive (with crank pulley + alternator bracket & p/s bracket)	-	-	-	\$2,499
1CA400-PS	1CB400-PS	with ProCharger bracket, tensioner and 8 rib belt	-	-	-	\$3,099
1CA300-AC	1CB300-AC	Serpentine Accessory Drive (with crank pulley + alternator bracket & a/c bracket)	-	-	-	\$2,399
1CA400-4C	1CB400-4C	with ProCharger bracket, tensioner and 8 rib belt	-	-	-	\$2,999
1CA300-PS-AC	1CB300-PS-AC	Serpentine Accessory Drive (with crank pulley + alternator bracket, p/s bracket & a/c bracket)	-	-	-	\$2,699
1CA400-PS-AC	1CB400-PS-AC	with ProCharger bracket, tensioner and 8 rib belt	-	-	-	\$3,299
1CA400-P1SC	1CB400-P1SC	Serpentine Accessory Drive Kit with P-1SC-1 (with all accessory brackets)	specify	specify	-	\$5,699
1CA400-P1SC-1	1CB400-P1SC-1	Serpentine Accessory Drive Kit with Intercooled P-1SC-1 (with all acc brackets)	specify	specify	2 core (550 hp)	\$6,599
1CA400-P1X	1CB400-P1X	Serpentine Accessory Drive Kit with P-1X (with all accessory brackets)	specify	specify	-	\$5,949
1CA400-P-1X-I	1CB400-P-1X-I	Serpentine Accessory Drive Kit with Intercooled P-1X (with all accessory brackets)	specify	specify	2 core (550 hp)	\$6,849
1CA400-D1SC	1CB400-D1SC	Serpentine Accessory Drive Kit with D-1SC (with all accessory brackets)	specify	specify	-	\$5,999
1CA400-D1SC-I	1CB400-D1SC-I	Serpentine Accessory Drive Kit with Intercooled D-1SC (with all accessory brackets)	specify	specify	3 core (825 hp)	\$7,399
1CA400-D1X	1CB400-D1X	Serpentine Accessory Drive Kit with D-1X (with all accessory brackets)	specify	specify	-	\$6,199
1CA400-D1X-I	1CB400-D1X-I	Serpentine Accessory Drive Kit with Intercooled D-1X (with all acc brackets)	specify	specify	3 core (825 hp)	\$7,399
1CA400-F1D/F1/F1A	1CB400-F1D/F1/F1A	Serpentine Accessory Drive Kit with F-1D, F-1, or F-1A (with all accessory brackets)	specify	specify	-	\$7,149
1CA400-F1D-I/F1-I/F1A-I	1CB400-F1D-I/F1-I/F1A-I	Serpentine Accessory Drive Kit with Intercooled F-1D, F-1, or F-1A (with w/p and all acc brackets)	specify	specify	Sht mtl 3C (950 hp)	\$8,499
1CA400-F1A94/F1C/F1R	1CB400-F1A94/F1C/F1R	Serpentine Accessory Drive Kit with F-1A-94, F-1C or F-1R (with all accessory brackets)	specify	specify	-	\$7,499
1CA400-F1A94-I/F1C-I/F1R-I	1CB400-F1A94-I/F1C-I/F1R-I	Serpentine Accessory Drive Kit with Intercooled F-1A-94, F-1C or F-1R (w/p and all acc brackets)	specify	specify	Sht mtl 3C (1050 hp)	\$8,999
1CA400-F1X	1CB400-F1X	Serpentine Accessory Drive Kit with F-1X (10 rib) (with all accessory brackets)	specify	specify	-	\$9,049
1CA400-F1X-I	1CB400-F1X-I	Serpentine Accessory Drive Kit with Intercooled F-1X (10 rib) with w/p and all acc brackets)	specify	specify	Sht mtl 3C (1300 hp)	\$10,549
1CA400-F2	1CB400-F2	Serpentine Accessory Drive Kit with F-2 (10 rib) (with all accessory brackets)	specify	specify	-	\$9,249
1CA400-F2-I	1CB400-F2-I	Serpentine Accessory Drive Kit with Intercooled F-2 (10 rib) (with w/p and all acc brackets)	specify	specify	Sht mtl 3C (1300 hp)	\$10,749
SBC/BBC Serpentine Accessory Drive Kit Options	add "-B" or "-P" to part #	Black or Polished finish for ProCharger (P-series or D-series)	satin standard	-	-	+\$325
	add "-B" or "-P" to part #	Black or Polished finish for ProCharger (F-series 9"-9.75" housing)	satin standard	-	-	+\$375
	add "-B" or "-P" to part #	Black or Polished finish for ProCharger (F-series, 10.5" housing)	satin standard	-	-	+\$425
	add "-BAC" or "-PAC"	Black or Polished finish for air conditioning bracket	satin standard	-	-	+\$75
	add "-BPB" or "-PPB"	Black or Polished finish for power steering bracket	satin standard	-	-	+\$75
	add "-BB" or "-PB" to part #	Black or Polished finish for supercharger bracket, water pump, alternator bracket, and tensioner	satin standard	-	-	+\$450
	add "-BC" or "-PC" to part #	Black or Polished finish for carburetor bonnet	satin standard	-	-	+\$100
	add "-H" to part #	Helical gearsset for noise reduction (P-1SC-1, P-1X, D-1SC, D-1X)	same	same	-	+\$110
	add "-OPB"	Omit power steering belt, bracket & pulley	-	-	-	-\$300
	add "-OAB"	Omit air conditioning bracket & pulley	-	-	-	-\$200
	3CXBB-006	Add ProCharger supercharger bracket 8 rib, tensioner & belt (included with 1CA400 & 1CB400)	from 1CX300	-	-	+\$1628
	add "-10R" to part #	10-Rib supercharger drive belt (from 8 rib)	from 8 rib	-	-	+\$375
	call	Add water pump	-	-	-	call
	call	Add Satin / Black / Chrome alternator	-	-	-	call
	call	Add Satin / Black / Chrome power steering pump	-	-	-	call
call	Add Satin / Black / Chrome air conditioning compressor	-	-	-	call	
AI003A-001	3 core intercooler (825 hp)	from non-ic kit	3" in/outlet	-	+\$1,198	
AI003A-002	Sheet metal 3 core race intercooler (950 hp)	from non-ic kit	3" in/outlet	-	+\$1,398	
AI003A-005	Sheet metal 3 core race intercooler (1050 hp)	from non-ic kit	3.5" in/outlet	-	+\$1,498	
AI045A-001	Sheet metal 3 core race intercooler (1300 hp)	from non-ic kit	3.5" in/outlet	-	+\$1,798	
AM009A-001	Standard Carb Hat 4150 (3.5" Inlet, 2.75" Height satin)	-	-	-	\$242	
AM001A-001	Competition Carb Hat 4150 (3.5" Inlet, 4.5" Height satin)	-	-	-	\$292	
AM001A-002P	Competition Carb Hat 4500 (5" Inlet, 5.5" Height Polished Finish)	-	-	-	\$468	



FOR MORE INFORMATION:

SCAN CODE WITH PHONE OR VISIT:

**PROCHARGER.COM/SBC-BBC-ACCESSORY-DRIVE-KIT**

# SPECIFICATIONS (SMALL BLOCK & BIG BLOCK CHEVY)

## **\*NEW\*** SBC/BBC SERPENTINE ACCESSORY DRIVE KIT SPECIFICATIONS

Part Number SBC	Part Number BBC	Stock HP	HP Gain	Tube Diam	Carb Hat	Drive System	Bypass Valve	Water Pump	Alternator Bracket	Power Steering Bracket	Air Cond. Bracket	Supercharger Warranty (in months)	Tubing Supplied	Foot Notes
1CA300	1CB300	N/A	specify	-	optional	6 rib Acc Drive	-	-	included	-	-	12	-	all
1CA400	1CB400	N/A	specify	-	optional	6 rib / 8 rib	-	-	included	-	-	12	-	all
1CA300-PS	1CB300-PS	N/A	specify	-	optional	6 rib Acc Drive	-	-	included	included	-	12	-	all
1CA400-PS	1CB400-PS	N/A	specify	-	optional	6 rib / 8 rib	-	-	included	included	-	12	-	all
1CA300-AC	1CB300-AC	N/A	specify	-	optional	6 rib Acc Drive	-	-	included	-	included	12	-	all
1CA400-4C	1CB400-4C	N/A	specify	-	optional	6 rib / 8 rib	-	-	included	-	included	12	-	all
1CA300-PS-AC	1CB300-PS-AC	N/A	specify	-	optional	6 rib Acc Drive	-	-	included	included	included	12	-	all
1CA400-PS-AC	1CB400-PS-AC	N/A	specify	-	optional	6 rib / 8 rib	-	-	included	included	included	12	-	all
1CA400-P1SC	1CB400-P1SC	N/A	specify	-	optional	6 rib / 8 rib	ProFlow	-	included	included	included	12	-	all
1CA400-P1SC-1	1CB400-P1SC-1	N/A	specify	3"	optional	6 rib / 8 rib	ProFlow	-	included	included	included	12	yes	all
1CA400-P1X	1CB400-P1X	N/A	specify	-	optional	6 rib / 8 rib	ProFlow	-	included	included	included	12	-	all
1CA400-P-1X-I	1CB400-P-1X-I	N/A	specify	3"	optional	6 rib / 8 rib	ProFlow	-	included	included	included	12	yes	all
1CA400-D1SC	1CB400-D1SC	N/A	specify	-	optional	6 rib / 8 rib	ProFlow	-	included	included	included	12	-	all
1CA400-D1SC-1	1CB400-D1SC-1	N/A	specify	3"	optional	6 rib / 8 rib	ProFlow	-	included	included	included	12	yes	all
1CA400-D1X	1CB400-D1X	N/A	specify	-	optional	6 rib / 8 rib	ProFlow	-	included	included	included	12	-	all
1CA400-D1X-I	1CB400-D1X-I	N/A	specify	3"	optional	6 rib / 8 rib	ProFlow	-	included	included	included	12	yes	all
1CA400-F1D/F1A	1CB400-F1D/F1A	N/A	specify	-	optional	6 rib / 8 rib	Race Valve	-	included	included	included	12	-	all
1CA400-F1D-I/F1-I/F1A-I	1CB400-F1D-I/F1-I/F1A-I	N/A	specify	3"	optional	6 rib / 8 rib	Race Valve	-	included	included	included	12	yes	all
1CA400-F1A94/F1C/F1R	1CB400-F1A94/F1C/F1R	N/A	specify	-	optional	6 rib / 8 rib	Race Valve	-	included	included	included	12	-	all
1CA400-F1A94-I/F1C-I/F1R-I	1CB400-F1A94-I/F1C-I/F1R-I	N/A	specify	3.5"	optional	6 rib / 8 rib	Race Valve	-	included	included	included	12	yes	all
1CA400-F1X	1CB400-F1X	N/A	specify	-	optional	6 rib / 10 rib	Race Valve	-	included	included	included	12	-	all
1CA400-F1X-I	1CB400-F1X-I	N/A	specify	3.5"	optional	6 rib / 10 rib	Race Valve	-	included	included	included	12	yes	all
1CA400-F2	1CB400-F2	N/A	specify	-	optional	6 rib / 10 rib	Race Valve	-	included	included	included	12	-	all
1CA400-F2-I	1CB400-F2-I	N/A	specify	3.5"	optional	6 rib / 10 rib	Race Valve	-	included	included	included	12	yes	all



FOR MORE INFORMATION:  
SCAN CODE WITH PHONE OR VISIT:  
**PROCHARGER.COM/SBC-BBC-ACCESSORY-DRIVE-KIT**

### SBC/BBC ACCESSORY DRIVE FOOTNOTES (specific to above applications):

- MM1) Uses factory balancer or aftermarket factory replacement
- MM2) Can be ordered without a/c
- MM3) Can be ordered without power steering

### COMPATIBLE GM ACCESSORIES

Description	Part #	Manufacturer/Notes
Power Steering Pump	6175AL	Tuff Stuff (or equivalent), GM Type 2
Alternator	CS130	6.14 center bolt spacing
A/C Compressor	SD-7B10	Sanden, 6-rib
Water Pump, SBC	8815	Edelbrock (or similar), 84-91 reverse rotation
Water Pump, BBC	8854	Edlebrock (or similar), GM Truck



CONTACT US AT (913) 338-2886 OR LEARN MORE AT [PROCHARGER.COM](http://PROCHARGER.COM)

## SBC/BBC SERPENTINE BLOWER KITS (V-BELT ACCESSORIES)

Part Number SBC	Part Number BBC	Description	Boost Options	HP Gain	Intercooler	Price/MAP
1CA100-P600B*	1CB100-P600B*	High Output with P600B (8 rib)	specify	specify	-	\$3,949
1CA100-P1SC*	1CB100-P1SC*	High Output with P-1SC (8 rib)	specify	specify	-	\$4,349
1CA100-P1SC-I*	1CB100-P1SC-I*	High Output Intercooled with P-1SC (8 rib)	specify	specify	2 core (550hp)	\$5,499
1CA100-D1*	1CB100-D1*	High Output with D-1 (12 rib)	specify	specify	-	\$5,099
1CA100-D1SC*	1CB100-D1SC*	High Output with D-1SC (12 rib)	specify	specify	-	\$5,099
1CA100-D1SC-I*	1CB100-D1SC-I*	High Output Intercooled with D-1SC (12 rib)	specify	specify	3 core (825hp)	\$6,599
1CA100-F1D/F1/F1A*	1CB100-F1D/F1/F1A*	High Output with F-1D, F-1, F-1A (12 rib)	specify	specify	-	\$6,299
1CA100-F1D-I/F1-I/F1A-I*	1CB100-F1D-I/F1-I/F1A-I*	High Output Intercooled with F-1D, F-1, F-1A (12 rib)	specify	specify	Sht mtl 3C (950hp)	\$7,799
1CA100-F1A94/F1C/F1R*	1CB100-F1A94/F1C/F1R*	High Output with F-1A-94, F-1C, F-1R (12 rib)	specify	specify	-	\$6,699
1CA100-F1A94-I/F1C-I/F1R-I*	1CB100-F1A94-I/F1C-I/F1R-I*	High Output Intercooled with F-1A-94, F-1C, F-1R (12 rib)	specify	specify	Sht mtl 3C (1050hp)	\$8,199
1CA100-F1X	1CB100-F1X	High Output with F-1X (12 rib)	specify	specify	-	\$7,099
1CA100-F1X-I*	1CB100-F1X-I*	High Output Intercooled with F-1X (12 rib)	specify	specify	Sht mtl (1300hp)	\$8,999
1CA100-F2*	1CB100-F2*	High Output with F-2 (12 rib)	specify	specify	-	\$7,399
1CA100-F2-I*	1CB100-F2-I*	High Output Intercooled with F-2 (12 rib)	specify	specify	Sht mtl (1300hp)	\$9,299

SBC/BBC SERPENTINE KIT OPTIONS	add "-B" or "-P" to part #	Black or Polished finish for ProCharger (P-series or D-series)	satin standard	-	-	+\$325
	add "-B" or "-P" to part #	Black or Polished finish for ProCharger (F-series 9"-9.75" housing)	satin standard	-	-	+\$350
	add "-B" or "-P" to part #	Black or Polished finish for ProCharger (F-series, 10.5" housing)	satin standard	-	-	+\$375
	add "-BB" or "-PB" to part #	Black or Polished finish for main bracket(s) and tensioner	satin standard	-	-	+\$275
	add "-BSB" or "-PSB" to part #	Black or Polished finish for serpentine accessory drive bracket	satin standard	-	-	+\$225
	add "-BC" or "-PC" to part #	Black or Polished finish for carburetor bonnet	satin standard	-	-	+\$100
	add "-H" to part #	Helical gearset for noise reduction (P-1SC, P-1X, D-1SC, D-1X)	same	-	-	+\$110
	add "-P1X" to part #	With P-1X ProCharger (replacing P-1SC)	same	add'l 10-15+ hp	-	+\$470
	add "-D1SC" to part #	With D-1SC ProCharger (replacing P-1SC)	-	specify	-	+\$495
	add "-D1X" to part #	With D-1X ProCharger (replacing P-1SC)	tuner kit only	specify	-	+\$695
	add "-D1X" to part #	With D-1X ProCharger (replacing D-1SC)	tuner kit only	specify	-	+\$200
	add "-CB" to part #	Competition Carb Bonnet Upgrade	from standard	-	-	+\$50
	add "-CB" to part #	Competition Carb Bonnet Upgrade	from low-profile	-	-	+\$72
	1CX110-SC-SBA*	Serpentine Accessory Drive SBC/BBC (time of purchase, see R8)	req Sanden a/c	-	-	+\$915
	1CX110-SC-SB*	Serpentine Accessory Drive SBC/BBC (time of purchase, see R8)	without a/c	-	-	+\$915
	AI003A-001	3 core intercooler (825 hp)	from non-ic kit	3" in/outlet	-	+\$1,198
	AI003A-002	Sheet metal 3 core race intercooler (950 hp)	from non-ic kit	3" in/outlet	-	+\$1,398
	AI003A-005	Sheet metal 3 core race intercooler (1050 hp)	from non-ic kit	3.5" in/outlet	-	+\$1,498
	AI045A-001	Sheet metal 3 core race intercooler (1300 hp)	from non-ic kit	3.5" in/outlet	-	+\$1,798
	AI006A-001	Sheet metal 3 core race intercooler (1550 hp)	from non-ic kit	4" in/outlet	-	+\$2,298
	3CASS-002	ProFlow bypass valve kit	-	-	-	+\$268
	AV006A-003	Bullet Bypass/Anti-Surge Valve - Closed	-	-	-	+\$388
	AV006A-004	Bullet Bypass/Anti-Surge Valve - Open	-	-	-	+\$388
	3FASS-00X	Race Bypass Valve, Open or Closed (aluminum or steel flange)	red or black	-	-	+\$498
	FV001I-BST	Boost sensitive fuel pressure regulator (EFI or Carb)	-	-	-	+\$285
	FV002I-BST	Boost sensitive fuel pressure regulator (Carb, 1000hp capable)	-	-	-	+\$315
	FP001I-002	ProPump fuel pump 700 hp	-	-	-	+\$330
FP001I-006	High Performance 1000 hp electric fuel pump	-	-	-	+\$438	
AB00XX-000	BB/SB p/s reloc. kit (remote reservoir) pump not included (V-belt)	for Jayco	-	-	+\$298	
AB007A-085	SBC Repositioning bracket	-	-	-	+\$109	
AB008A-065	BBC Repositioning bracket	-	-	-	+\$109	



# SPECIFICATIONS (SMALL BLOCK & BIG BLOCK CHEVY)

## SBC/BBC SERPENTINE BLOWER KIT (V-BELT ACCESSORIES) SPECIFICATIONS

Part Number SBC	Part Number BBC	Stock HP	HP Gain	Tube Diam	Carb Hat	Drive System	Bypass Valve	Power Steering Relocation Kit (optional)	A/C Installation Kit (optional)	SC Warranty (in months)	Tubing Supplied	Foot Notes
1CA100-P600B*	1CB100-P600B*	N/A	specify	-	low profile	add'l 8 rib	Sold separately	Jayco Remote Reservoir	Yes	12	-	R1, R2, R3, R6, R7, R8
1CA100-P1SC*	1CB100-P1SC*	N/A	specify	-	low profile	add'l 8 rib	Sold separately	Jayco Remote Reservoir	Yes	12	-	R1, R2, R3, R6, R7, R8
1CA100-P1SC-I*	1CB100-P1SC-I*	N/A	specify	3"	std	add'l 8 rib	ProFlow	Jayco Remote Reservoir	Yes	12	Yes	R1, R2, R4, R6, R7, R8
1CA100-D1*	1CB100-D1*	N/A	specify	-	std	add'l 12 rib	Sold separately	Jayco Remote Reservoir	Yes	12	-	R1, R2, R3, R6, R7, R8
1CA100-D1SC*	1CB100-D1SC*	N/A	specify	-	std	add'l 12 rib	Sold separately	Jayco Remote Reservoir	Yes	12	-	R1, R2, R3, R6, R7, R8
1CA100-D1SC-I*	1CB100-D1SC-I*	N/A	specify	3"	std	add'l 12 rib	ProFlow	Jayco Remote Reservoir	Yes	12	Yes	R1, R2, R4, R6, R7, R8
1CA100-F1D/F1/F1A*	1CB100-F1D/F1/F1A*	N/A	specify	-	std	add'l 12 rib	Race Valve	Jayco Remote Reservoir	Yes	12	-	R1, R2, R5, R6, R7, R8
1CA100-F1D-I/F1-I/F1A-I*	1CB100-F1D-I/F1-I/F1A-I*	N/A	specify	3"	std	add'l 12 rib	Race Valve	Jayco Remote Reservoir	Yes	12	Yes	R1, R2, R4, R5, R6, R7, R8
1CA100-F1A94/F1C/F1R*	1CB100-F1A94/F1C/F1R*	N/A	specify	-	std	add'l 12 rib	Race Valve	Jayco Remote Reservoir	Yes	12	-	R1, R2, R5, R6, R7, R8
1CA100-F1A94-I/F1C-I/F1R-I*	1CB100-F1A94-I/F1C-I/F1R-I*	N/A	specify	3.5"	std	add'l 12 rib	Race Valve	Jayco Remote Reservoir	Yes	12	Yes	R1, R2, R4, R5, R6, R7, R8
1CA100-F1X	1CB100-F1X	N/A	specify	-	std	add'l 12 rib	Race Valve	Jayco Remote Reservoir	Yes	12	-	R1, R2, R5, R6, R7, R8
1CA100-F1X-I*	1CB100-F1X-I*	N/A	specify	3.5"	std	add'l 12 rib	Race Valve	Jayco Remote Reservoir	Yes	12	Yes	R1, R2, R4, R5, R6, R7, R8
1CA100-F2*	1CB100-F2*	N/A	specify	-	std	add'l 12 rib	Race Valve	Jayco Remote Reservoir	Yes	12	-	R1, R2, R5, R6, R7, R8
1CA100-F2-I*	1CB100-F2-I*	N/A	specify	3.5"	std	add'l 12 rib	Race Valve	Jayco Remote Reservoir	Yes	12	Yes	R1, R2, R4, R5, R6, R7, R8

### SBC/BBC SERPENTINE BLOWER FOOTNOTES (specific to above applications):

- R1) Carbureted systems require 4150 style or similar blow-through carburetor or efi throttle body (sold separately by others) and fuel system upgrade (sold by ProCharger and others)
- R2) Must provide own P/S pump with remote reservoir, GM Type II Pump (both Serpentine and V-Groove)
- R3) Purchase of bypass valve recommended above 8 psi, or with intercooler (sold separately by ProCharger)
- R4) Universal Tubing Kit included, not designed for a specific vehicle
- R5) Cog may be required above 1,000 hp
- R6) A/C option on serpentine accessory drive requires Sanden A/C compressor 508/SD5H14 (sold separately by others)
- R7) V-Groove accessory drive requires standard rotation, long water pump (SB and BB)  
Serpentine accessory drive requires reverse rotation water pump: SB requires 1984-91 Corvette reverse rotation water pump (sold separately by others),  
BB requires reverse rotation BB water pump (Edelbrock part #8854, sold separately by others);
- R8) Alternator placement with serpentine accessory drive is not compatible with some aftermarket EFI systems; designed to work with Delco style alternator with 6.61" center to center mounting

## SBC/BBC COG BLOWER RACE KITS (V-BELT ACCESSORIES)

Part Number SBC	Part Number BBC	Description	Boost Options	HP Gain	Intercooler	Price/MAP
1CA200-F1D/F1/F1A*	1CB200-F1D/F1/F1A*	Cog Race Kit with F-1D, F-1, F-1A	specify	specify	-	\$6,499
1CA200-F1D-I/F1-I/F1A-I*	1CB200-F1D-I/F1-I/F1A-I*	<b>Intercooled Cog Race Kit with F-1D, F-1, or F-1A</b>	specify	specify	Sht mtl 3C (950hp)	\$7,899
1CA200-F1A94/F1C/F1R*	1CB200-F1A94/F1C/F1R*	Cog Race Kit with F-1A-94, F-1C, F-1R	specify	specify	-	\$6,999
1CA200-F1A94-I/F1C-I/F1R-I*	1CB200-F1A94-I/F1C-I/F1R-I*	<b>Intercooled Cog Race Kit with F-1A-94, F-1C or F-1R</b>	specify	specify	Sht mtl 3C (1050hp)	\$8,399
1CA200-F1X*	1CB200-F1X*	Cog Race Kit with F-1X	specify	specify	-	\$7,699
1CA200-F1X-I*	1CB200-F1X-I*	<b>Intercooled Cog Race Kit with F-1X</b>	specify	specify	Sht mtl (1300hp)	\$9,549
1CA200-F2*	1CB200-F2*	Cog Race Kit with F-2	specify	specify	-	\$7,799
1CA200-F2-I*	1CB200-F2-I*	<b>Intercooled Cog Race Kit with F-2</b>	specify	specify	Sht mtl (1300hp)	\$9,659
1CA200-F3R-spec*	1CB200-F3R-spec*	Cog Race Kit with F-3R-112 (F-1X-12)	specify	specify	-	\$8,699
1CA200-F3R-spec*	1CB200-F3R-spec*	Cog Race Kit with F-3R-121	specify	specify	-	\$9,099
1CA200-F3R-spec*	1CB200-F3R-spec*	Cog Race Kit with F-3R-130 or -136	specify	specify	-	\$9,299
1CA200-F1XR*	1CB200-F1XR*	Reverse Rotation Cog Race Kit with F-1X	specify	specify	-	\$8,099
1CA200-F2R*	1CB200-F2R*	Reverse Rotation Cog Race Kit with F-2	specify	specify	-	\$8,199
1CA200-F3RR-spec*	1CB200-F3RR-spec*	Reverse Rotation Cog Race Kit with F-3R-121	specify	specify	-	\$9,799
1CA200-F3RR-spec*	1CB200-F3RR-spec*	Reverse Rotation Cog Race Kit with F-3R-130 or -136	specify	specify	-	\$10,099

SBC/BBC COG RACE KIT OPTIONS	add "-B" or "-P" to part #	Black or Polished finish for ProCharger (P-series or D-series)	satin standard	-	-	+\$325
	add "-B" or "-P" to part #	Black or Polished finish for ProCharger (F-series, 9" or 9.75" housing)	satin standard	-	-	+\$350
	add "-B" or "-P" to part #	Black or Polished finish for ProCharger (F-series, 10.5" housing)	satin standard	-	-	+\$375
	add "-BB" or "-PB" to part #	Black or Polished finish for main bracket and tensioner	satin standard	-	-	+\$275
	add "-BSB" or "-PSB" to part #	Black or Polished finish for serpentine accessory drive bracket	satin standard	-	-	+\$225
	add "-BC" or "-PC" to part #	Black or Polished finish for carburetor bonnet	satin standard	-	-	+\$100
	add "-102/106"	With F-3D-102/106 (replacing F-3R-112)	specify	-	-	-\$400
	3FASS-00X	Race Bypass Valve, open or closed (included in Race kits)	red or black	-	-	+\$498
	add "-PRV" to part #	ProRace Bypass Valve (From Race Valve, v-band clamp mounting)	specify	-	-	+\$270
	add "-PRV" to part #	ProRace Bypass Valve (v-band clamp mounting)	specify	-	-	+\$768
	add "-CB" to part #	Competition Carb Bonnet Upgrade 4150 (at time of kit purchase)	from standard	-	-	+\$50
	add "-DCP"	Competition Carb Bonnet Upgrade 4500 polished finish (at time of kit purchase)	from standard	-	-	+\$150
	add "-DCB"	Competition Carb Bonnet Upgrade 4500 black finish (at time of kit purchase)	from standard	-	-	+\$266
	AM001A-001	Competition Carb Bonnet 4150 (3.5" Inlet, 4.5" Height Satin Finish)	-	-	-	+\$292
	AM001A-002P	Competition Carb Bonnet 4500 (5" Inlet, 5.5" Height Polished Finish)	-	-	-	+\$468
	AM001A-002B	Competition Carb Bonnet 4500 (5" Inlet, 5.5" Height Black Finish)	-	-	-	+\$508
	1CX210-SCA*	Serpentine Accessory Drive SBC/BBC (at time of kit purchase)	req Sanden a/c	-	-	+\$915
	1CX210-SC*	Serpentine Accessory Drive SBC/BBC (at time of kit purchase)	without a/c	-	-	+\$915
	AI003A-002	Sheet metal 3 core race intercooler (950 hp)	from non-ic kit	3" in/outlet	-	+\$1,398
	AI003A-005	Sheet metal 3 core race intercooler (1050 hp)	from non-ic kit	3.5" in/outlet	-	+\$1,498
	AI045A-001	Sheet metal 3 core race intercooler (1300 hp)	from non-ic kit	3.5" in/outlet	-	+\$1,798
	AI006A-001	Sheet metal 3 core race intercooler (1550 hp)	from non-ic kit	4" in/outlet	-	+\$2,298
	WI1005A-003	Air/water race intercooler (race use only)	-	1,250 hp max	-	+\$1,898
WI1005A-001	Air/water race intercooler (race use only)	-	1,800 hp max	-	+\$2,498	
WI1005A-002	Air/water race intercooler (race use only)	-	2,500+ hp max	-	+\$2,998	
AB007A-085	SB Repositioning bracket	-	-	-	+\$109	
AB008A-065	BB Repositioning bracket	-	-	-	+\$109	
FV002I-BST	Boost sensitive fuel pressure regulator (Carb only, 1000 hp compatible)	-	-	-	+\$315	
FP001I-006	High Performance 1000 hp electric fuel pump	-	-	-	+\$438	

FOR CRANKDRIVE AND RACEDRIVE DETAILS, VISIT PROCHARGER.COM

# SPECIFICATIONS (SMALL BLOCK & BIG BLOCK CHEVY)

## SBC/BBC COG BLOWER RACE KIT (V-BELT ACCESSORIES) SPECIFICATIONS

Part Number SBC	Part Number BBC	Stock HP	HP Gain	Tube Diam	Carb Hat	Drive System	Bypass Valve	Power Steering Relocation Kit (optional)	A/C Installation Kit (optional)	SC Warranty (in months)	Tubing Supplied	Foot Notes
1CA200-F1D/F1/F1A*	1CB200-F1D/F1/F1A*	N/A	specify	-	Standard	8 x 50 mm cog	Race Valve	Jayco Remote Reservoir	Yes	Limited	-	S: 1, 3, 4, 5, 6, 7
1CA200-F1D-I/F1-I/F1A-I*	1CB200-F1D-I/F1-I/F1A-I*	N/A	specify	3"	Standard	8 x 50 mm cog	Race Valve	Jayco Remote Reservoir	Yes	Limited	Yes	S: 1, 2, 3, 4, 5, 6, 7
1CA200-F1A94/F1C/F1R*	1CB200-F1A94/F1C/F1R*	N/A	specify	-	Standard	8 x 50 mm cog	Race Valve	Jayco Remote Reservoir	Yes	Limited	-	S: 1, 3, 4, 5, 6, 7
1CA200-F1A94-I/F1C-I/F1R-I*	1CB200-F1A94-I/F1C-I/F1R-I*	N/A	specify	3.5"	Standard	8 x 50 mm cog	Race Valve	Jayco Remote Reservoir	Yes	Limited	Yes	S: 1, 2, 3, 4, 5, 6, 7
1CA200-F1X*	1CB200-F1X*	N/A	specify	-	Standard	8 x 50 mm cog	Race Valve	Jayco Remote Reservoir	Yes	Limited	-	S: 1, 3, 4, 5, 6, 7
1CA200-F1X-I*	1CB200-F1X-I*	N/A	specify	3.5"	Standard	8 x 50 mm cog	Race Valve	Jayco Remote Reservoir	Yes	Limited	Yes	S: 1, 2, 3, 4, 5, 6, 7
1CA200-F2*	1CB200-F2*	N/A	specify	-	Standard	8 x 50 mm cog	Race Valve	Jayco Remote Reservoir	Yes	Limited	-	S: 1, 3, 4, 5, 6, 7
1CA200-F2-I*	1CB200-F2-I*	N/A	specify	3.5"	Standard	8 x 50 mm cog	Race Valve	Jayco Remote Reservoir	Yes	Limited	Yes	S: 1, 2, 3, 4, 5, 6, 7
1CA200-F3R-spec*	1CB200-F3R-spec*	N/A	specify	-	-	14 x 55 mm cog	ProRace Valve	-	-	Limited	-	-
1CA200-F3R-spec*	1CB200-F3R-spec*	N/A	specify	-	-	14 x 55 mm cog	ProRace Valve	-	-	Limited	-	-
1CA200-F1XR*	1CB200-F1XR*	N/A	specify	-	-	8 x 75 mm cog	Race Valve	-	-	Limited	-	-
1CA200-F2R*	1CB200-F2R*	N/A	specify	-	-	8 x 75 mm cog	Race Valve	-	-	Limited	-	-
1CA200-F3RR-spec*	1CB200-F3RR-spec*	N/A	specify	-	-	8 x 75 mm cog	ProRace Valve	-	-	Limited	-	-
1CA200-F3RR-spec*	1CB200-F3RR-spec*	N/A	specify	-	-	8 x 75 mm cog	ProRace Valve	-	-	Limited	-	-

### SBC/BBC COG BLOWER FOOTNOTES (specific to above applications):

- S1) Carbureted systems require 4150 style or similar blow-through carburetor or efi throttle body (sold separately by others) and fuel system upgrade (sold by ProCharger and others)
- S2) Universal Intercooler Tubing Kit included, not designed for a specific vehicle
- S3) Electric water pump recommended with V-belt; Mechanical water pump recommended for Serpentine (must use short style pump)
- S4) Must provide own P/S pump with remote reservoir, GM Type II Pump (both Serpentine and V-Groove)
- S5) A/C option on serpentine accessory drive requires Sanden A/C compressor 508/SD5H14 (sold separately by others)
- S6) Serpentine accessory drive requires reverse rotation water pump: SB requires 1984-91 Corvette reverse rotation water pump (sold separately by others), BB requires reverse rotation BB water pump (Edelbrock part #8854, sold separately by others)
- S7) Alternator placement with serpentine accessory drive is not compatible with some aftermarket EFI systems; designed to work with Delco style alternator with 6.61" center to center mounting

**2011-23 DODGE CHALLENGER HEMI (6.4) SYSTEMS AND KITS**

Year	Part Number	Description	Boost Options	HP Gain	Intercooler	Price/MAP
2015-23	1DG515-SCI	High Output Intercooled System with P-1SC-1	7 psi	200+/215+* hp	3 Core	\$8,399
2015-23	1DG505-SCI	High Output Intercooled Tuner Kit with P-1SC-1	specify	specify	3 Core	\$7,149
2015-19	1DG415-SCI	Stage II Intercooled System with P-1SC-1	7 psi	200+/215+* hp	3 Core	\$9,499
2015-19	1DG405-SCI	Stage II Intercooled Tuner Kit with P-1SC-1	specify	specify	3 Core	\$8,249
2011-14	1DG314-SCI	High Output Intercooled System with P-1SC-1	7 psi	200+ hp	3 Core	\$8,399
2011-14	1DG304-SCI	High Output Intercooled Tuner Kit with P-1SC-1	specify	specify	3 Core	\$7,149
2011-14	1DG214-SCI	Stage II Intercooled System with P-1SC-1	7 psi	200+ hp	3 Core	\$9,499
2011-14	1DG204-SCI	Stage II Intercooled Tuner Kit with P-1SC-1	specify	specify	3 Core	\$8,249

**2011-23 DODGE CHALLENGER HEMI (5.7) SYSTEMS AND KITS**

Year	Part Number	Description	Boost Options	HP Gain	Intercooler	Price/MAP
2015-23	1DF615-SCI	High Output Intercooled System with P-1SC-1	7 psi	160+ hp	3 Core	\$8,399
2015-23	1DF605-SCI	High Output Intercooled Tuner Kit with P-1SC-1	specify	specify	3 Core	\$7,149
2011-14	1DF414-SCI	High Output Intercooled System with P-1SC-1	7 psi	160+ hp	3 Core	\$8,099
2011-14	1DF404-SCI	High Output Intercooled Tuner Kit with P-1SC-1	specify	specify	3 Core	\$7,149

<b>2011-23 CHALLENGER (6.4, 5.7) OPTIONS</b>	add "-B" or "-P" to part #	Black or Polished finish for ProCharger (P-series or D-series)	satın standard	-	-	+\$325
	add "-B" or "-P" to part #	Black or Polished finish for ProCharger (F-series, 9" housing)	satın standard	-	-	+\$350
	add "-BB" or "-PB" to part #	Black or Polished finish for supercharger bracket	satın standard	-	-	+\$275
	add "-BI" to part #	Black finish for Intercooler (Race Intercooler Only)	satın standard	-	-	+\$175
	add "-H" to part #	Helical gearset for noise reduction (P-1SC-1, P-1X, D-1SC, D-1X)	same	same	-	+\$110
	add "-P1X" to part #	With P-1X ProCharger (replacing P-1SC-1, Systems and Tuner Kits)	same	add'l 10-15+ hp	-	+\$250
	add "-D1SC" to part #	With D-1SC ProCharger (replacing P-1SC-1)	tuner kit only	specify	-	+\$275
	add "-D1X" to part #	With D-1X ProCharger (replacing P-1SC-1, Tuner Kits only)	tuner kit only	specify	-	+\$475
	add "-D" or "-1" or "-A"	With F-1D, F-1, F-1A ProCharger (replacing P-1SC-1, Tuner Kits only)	tuner kit only	specify	-	+\$875
	add "-94" to part #	With F-1A-94 ProCharger (replacing P-1SC-1, Tuner Kits only)	tuner kit only	specify	-	+\$1,225
	add "-RVR" or "RVB"	Race Bypass Valve Upgrade (specify open or closed valve)	red or black	specify	-	+\$295
	add "-Race" to part #	Air-to-Air Race intercooler upgrade	from 3 core	1000 hp max	-	+\$435
add "-ATIPP" to part #	ATI Balancer Upgrade (6.4 Stage II Systems and Tuner Kits only)	-	-	-	+\$525	
add "-MS" to part #	MAP sensor adaptor bag	tuner kit only	same	-	+\$199	
add "-FP" to part #	In-Tank Fuel Pump	tuner kit only	same	-	+\$550	

**2015-22 DODGE CHALLENGER V6 (3.6) SYSTEMS AND KITS**

Year	Part Number	Description	Boost Options	HP Gain	Intercooler	Price/MAP
2015-22	1DQ214-SCI	High Output Intercooled System with P-1SC-1	7 psi	40-45%+	3 Core	\$7,399
2015-22	1DQ204-SCI	High Output Intercooled Tuner Kit with P-1SC-1	specify	specify	3 Core	\$6,349

<b>2015-22 CHALLENGER (3.6) OPTIONS</b>	add "-B" or "-P" to part #	Black or Polished finish for ProCharger (P-series or D-series)	satın standard	-	-	+\$325
	add "-B" or "-P" to part #	Black or Polished finish for ProCharger (F-series, 9" housing)	satın standard	-	-	+\$350
	add "-BB" or "-PB" to part #	Black or Polished finish for supercharger bracket	satın standard	-	-	+\$275
	add "-H" to part #	Helical gearset for noise reduction (P-1SC-1, P-1X, D-1SC, D-1X)	same	same	-	+\$110
	add "-P1X" to part #	With P-1X ProCharger (replacing P-1SC-1, Systems and Tuner Kits)	same	add'l 10-15+ hp	-	+\$250
	add "-D1SC" to part #	With D-1SC ProCharger (replacing P-1SC-1)	tuner kit only	specify	-	+\$275
	add "-D1X" to part #	With D-1X ProCharger (replacing P-1SC-1, Tuner Kits only)	tuner kit only	specify	-	+\$475
	add "-RVR" or "RVB"	Race Bypass Valve Upgrade (specify open or closed valve)	red or black	specify	-	+\$295
add "-MS" to part #	MAP sensor adaptor bag	tuner kit only	same	-	+\$199	



# SPECIFICATIONS (2011-23 CHALLENGER)

## 2011-23 DODGE CHALLENGER HEMI (6.4) SPECIFICATIONS

Year	Part Number	OEM hp Rating	HP Gain	Tube Diam	IC Mount	Drive System	Bypass System	Fuel System Upgrade	Fuel Inj. Supplied	Computer/Ignition Modifications	SC Warranty (in months)	CARB E.O.	Foot Notes
2015-23	1DG515-SCI	485	200+/215+* hp	3"	V	stk 6 rib	ProFlow	MAP sensor, pump/booster	52 lbs/hr	programmer supplied	12, 36 opt. (\$99)	D-365-26 (15-20)	V1, V3, V4, V5, V7, V8, V9, V11
2015-23	1DG505-SCI	485	specify	3"	V	stk 6 rib	ProFlow	not supplied	No	not supplied	12	-	V1, V3, V4, V5, V7, V8, V9
2015-19	1DG415-SCI	485	200+/215+* hp	3"	V	add'l 8 rib	ProFlow	MAP sensor, pump/booster	52 lbs/hr	programmer supplied	12, 36 opt. (\$99)	D-365-26 (15-20)	V1, V3, V4, V5, V6, V7, V8, V9, V11
2015-19	1DG405-SCI	485	specify	3"	V	add'l 8 rib	ProFlow	not supplied	No	not supplied	12	-	V1, V3, V4, V5, V6, V7, V8, V9
2011-14	1DG314-SCI	470	200+ hp	3"	V	stk 6 rib	ProFlow	MAP sensor, in-tank pump	52 lbs/hr	programmer supplied	12, 36 opt. (\$99)	D-365-22	V1, V3, V4, V5, V9
2011-14	1DG304-SCI	470	specify	3"	V	stk 6 rib	ProFlow	not supplied	No	not supplied	12	-	V1, V3, V4, V5, V9
2011-14	1DG214-SCI	470	200+ hp	3"	V	add'l 8 rib	ProFlow	MAP sensor, in-tank pump	52 lbs/hr	programmer supplied	12, 36 opt. (\$99)	D-365-22	V1, V3, V4, V5, V6, V9
2011-14	1DG204-SCI	470	specify	3"	V	add'l 8 rib	ProFlow	not supplied	No	not supplied	12	-	V1, V3, V4, V5, V6, V9

## 2011-23 DODGE CHALLENGER HEMI (5.7) SPECIFICATIONS

Year	Part Number	OEM hp Rating	HP Gain	Tube Diam	IC Mount	Drive System	Bypass System	Fuel System Upgrade	Fuel Inj. Supplied	Computer/Ignition Modifications	SC Warranty (in months)	CARB E.O.	Foot Notes
2015-23	1DF615-SCI	375	160+ hp	3"	V	stk 6 rib	ProFlow	MAP sensor, in-tank pump	39.5 lbs/hr	programmer supplied	12, 36 opt. (\$99)	D-365-22 (15-19)	V1, V3, V4, V5, V7, V8, V9, V10
2015-23	1DF605-SCI	375	specify	3"	V	stk 6 rib	ProFlow	not supplied	No	not supplied	12	-	V1, V3, V4, V5, V7, V9, V10
2011-14	1DF414-SCI	375	160+ hp	3"	V	stk 6 rib	ProFlow	MAP sensor	39.5 lbs/hr	programmer supplied	12, 36 opt. (\$99)	D-365-22	V1, V3, V4, V5, V9, V10
2011-14	1DF404-SCI	375	specify	3"	V	stk 6 rib	ProFlow	not supplied	No	not supplied	12	-	V1, V3, V4, V5, V9, V10

\* 215+ hp with HO Intercooled System and Race intercooler upgrade

## 2015-22 DODGE CHALLENGER V6 (3.6) SPECIFICATIONS

Year	Part Number	OEM hp Rating	HP Gain	Tube Diam	IC Mount	Drive System	Bypass System	Fuel System Upgrade	Fuel Inj. Supplied	Computer/Ignition Modifications	SC Warranty (in months)	CARB E.O.	Foot Notes
2015-22	1DQ214-SCI	305	40-45%+ hp	3"	V	add'l 6 rib	ProFlow	MAP sensor	50 lb/hr	programmer supplied	12, 36 opt. (\$99)	-	V1, V2, V4, V5, V8, V10
2015-22	1DQ204-SCI	305	specify	3"	V	add'l 6 rib	ProFlow	not supplied	No	not supplied	12	-	V1, V4, V5, V8, V10

## DODGE AUTOMOTIVE FOOTNOTES (specific to above applications):

- V1) Model year must be specified
- V2) Due to variability among OEM computers, the prevalence of custom modifications, and age/miles/condition of vehicles, dyno tuning may be required
- V3) Specify engine size (5.7 or 6.4)
- V4) Specify manual or automatic transmission
- V5) Systems ship in extra large box
- V6) Purchase of aftermarket balancer required, ATI PP part #918459 (not included - specify hardened hub)
- V7) Specify Shaker or standard hood
- V8) 2015+ vehicles may require ECM unlock (call for details)
- V9) Specify with or without strut bar
- V10) 2WD models only; AWD models must use Tuner Kit and may require modifications
- V11) 2015-20 supplied with in-tank pump, 2021+ supplied with fuel pump booster



CONTACT US AT (913) 338-2886 OR LEARN MORE AT PROCHARGER.COM

**2008-10 DODGE CHALLENGER HEMI SRT8 (6.1) SYSTEMS AND KITS**

Year	Part Number	Description	Boost Options	HP Gain	Intercooler	Price/MAP
2008-10	1DF314-SCI-6.1	<a href="#">High Output Intercooled System with P-1SC-1</a>	7 psi	160+ hp	3 Core	\$7,999
2008-10	1DF304-SCI-6.1	<a href="#">High Output Intercooled Tuner Kit with P-1SC-1</a>	specify	specify	3 Core	\$6,749
2008-10	1DF214-SCI-6.1	<a href="#">Stage II Intercooled System with P-1SC-1</a>	7 psi	160+ hp	3 Core	\$9,199
2008-10	1DF204-SCI-6.1	<a href="#">Stage II Intercooled Tuner Kit with P-1SC-1</a>	specify	specify	3 Core	\$7,949

<b>2008-10 CHALLENGER (6.1) OPTIONS</b>	add "-B" or "-P" to part #	Black or Polished finish for ProCharger (P-series or D-series)	satin standard	-	-	+\$325
	add "-B" or "-P" to part #	Black or Polished finish for ProCharger (F-series, 9" housing)	satin standard	-	-	+\$350
	add "-BB" to part #	Black finish for supercharger bracket (HO only)	satin standard	-	-	+\$275
	add "-PHO" to part #	Polished finish for HO supercharger bracket	satin standard	-	-	+\$275
	add "-PST" to part #	Polished finish for Stage II supercharger bracket	satin standard	-	-	+\$325
	add "-H" to part #	Helical gearset for noise reduction (P-1SC-1, P-1X, D-1SC, D-1X)	same	same	-	+\$110
	add "-P1X" to part #	With P-1X ProCharger (replacing P-1SC-1, Systems and Tuner Kits)	same	add'l 10-15+ hp	-	+\$250
	add "-D1SC" to part #	With D-1SC ProCharger (replacing P-1SC-1)	tuner kit only	specify	-	+\$275
	add "-D1X" to part #	With D-1X ProCharger (replacing P-1SC-1, Tuner Kits only)	tuner kit only	specify	-	+\$475
	add "-D" or "-1" or "-A"	With F-1D, F-1, F-1A ProCharger (replacing P-1SC-1, Stage II only)	tuner kit only	specify	-	+\$875
	add "-RVR" or "RVB"	Race Bypass Valve Upgrade (specify open or closed valve)	red or black	specify	-	+\$295
	add "-BU" to part #	Stage II belt upgrade (time of purchase, required for F-series models)	-	-	-	+\$75
add "-MS" to part #	MAP sensor adaptor bag	tuner kit only	same	-	+\$199	
add "-FP" to part #	In-Tank Fuel Pump	tuner kit only	same	-	+\$550	

**2008-10 DODGE CHALLENGER HEMI R/T (5.7) SYSTEMS AND KITS**

Year	Part Number	Description	Boost Options	HP Gain	Intercooler	Price/MAP
2008-10	1DF314-SCI-5.7	<a href="#">High Output Intercooled System with P-1SC-1</a>	7 psi	130+ hp	3 Core	\$7,699
2008-10	1DF304-SCI-5.7	<a href="#">High Output Intercooled Tuner Kit with P-1SC-1</a>	specify	specify	3 Core	\$6,749

<b>2008-10 CHALLENGER (5.7) OPTIONS</b>	add "-B" or "-P" to part #	Black or Polished finish for ProCharger (P-series or D-series)	satin standard	-	-	+\$325
	add "-B" or "-P" to part #	Black or Polished finish for ProCharger (F-series, 9" housing)	satin standard	-	-	+\$350
	add "-BB" to part #	Black finish for supercharger bracket (HO only)	satin standard	-	-	+\$275
	add "-PHO" to part #	Polished finish for HO supercharger bracket	satin standard	-	-	+\$275
	add "-PST" to part #	Polished finish for Stage II supercharger bracket	satin standard	-	-	+\$325
	add "-H" to part #	Helical gearset for noise reduction (P-1SC-1, P-1X, D-1SC, D-1X)	same	same	-	+\$110
	add "-P1X" to part #	With P-1X ProCharger (replacing P-1SC-1, Systems and Tuner Kits)	same	add'l 10-15+ hp	-	+\$250
	add "-D1SC" to part #	With D-1SC ProCharger (replacing P-1SC-1)	tuner kit only	specify	-	+\$275
	add "-D1X" to part #	With D-1X ProCharger (replacing P-1SC-1, Tuner Kits only)	tuner kit only	specify	-	+\$475
	add "-D" or "-1" or "-A"	With F-1D, F-1, F-1A ProCharger (replacing P-1SC-1)	tuner kit only	specify	-	+\$875
	add "-RVR" or "RVB"	Race Bypass Valve Upgrade (specify open or closed valve, Tuner Kits only)	red or black	specify	-	+\$295

# SPECIFICATIONS (2008-10 CHALLENGER)

## 2008-10 DODGE CHALLENGER HEMI SRT8 (6.1) SPECIFICATIONS

Year	Part Number	OEM hp Rating	HP Gain	Tube Diam	IC Mount	Drive System	Bypass System	Fuel System Upgrade	Fuel Inj. Supplied	Computer/Ignition Modifications	SC Warranty (in months)	CARB E.O.	Foot Notes
2008-10	1DF314-SCI	425	160+ hp	3"	V	stk 6 rib	ProFlow	MAP sensor, in-tank pump	39.5 lbs/hr	programmer supplied	12, 36 opt. (\$99)	D-365-7	W1, W3, W4, W5
2008-10	1DF304-SCI	425	specify	3"	V	stk 6 rib	ProFlow	not supplied	No	not supplied	12	-	W1, W3, W4, W5
2008-10	1DF214-SCI	425	160+ hp	3"	V	add'l 8 rib	ProFlow	MAP sensor, in-tank pump	39.5 lbs/hr	programmer supplied	12, 36 opt. (\$99)	-	W1, W2, W3, W4, W5, W6, W7
2008-10	1DF204-SCI	425	specify	3"	V	add'l 8 rib	ProFlow	not supplied	No	not supplied	12	-	W1, W3, W4, W5, W6, W7

## 2008-10 DODGE CHALLENGER HEMI R/T (5.7) SPECIFICATIONS

Year	Part Number	OEM hp Rating	HP Gain	Tube Diam	IC Mount	Drive System	Bypass System	Fuel System Upgrade	Fuel Inj. Supplied	Computer/Ignition Modifications	SC Warranty (in months)	CARB E.O.	Foot Notes
2008-10	1DF314-SCI	370	130+ hp	3"	V	stk 6 rib	ProFlow	MAP sensor	39.5 lbs/hr	programmer supplied	12, 36 opt. (\$99)	D-365-7 (09-10)	W1, W3, W4, W5
2008-10	1DF304-SCI	370	specify	3"	V	stk 6 rib	ProFlow	not supplied	No	not supplied	12	-	W1, W3, W4, W5

### DODGE AUTOMOTIVE FOOTNOTES (specific to above applications):

- W1) Model year must be specified
- W2) Due to variability among OEM computers, the prevalence of custom modifications, and age/miles/condition of vehicles, dyno tuning may be required
- W3) Specify engine size (5.7 or 6.1)
- W4) Specify manual or automatic transmission
- W5) Systems ship in extra large box
- W6) Purchase of aftermarket balancer required (not included - specify hardened hub):  
5.7 (2008) = ATI PP part #918435  
5.7 (2009-10) = ATI PP part #918445  
6.1 = ATI PP part #918432
- W7) Special order kit: order form and non-refundable deposit required at time of order—may require additional lead time for processing



**2012-23 DODGE CHARGER HEMI (6.4) SYSTEMS AND KITS**

Year	Part Number	Description	Boost Options	HP Gain	Intercooler	Price/MAP
2015-23	1DI515-SCI	High Output Intercooled System with P-1SC-1	7 psi	200+/215+* hp	3 Core	\$8,399
2015-23	1DI505-SCI	High Output Intercooled Tuner Kit with P-1SC-1	specify	specify	3 Core	\$7,149
2015-23	1DI415-SCI	Stage II Intercooled System with P-1SC-1	7 psi	200+/215+* hp	3 Core	\$9,499
2015-23	1DI405-SCI	Stage II Intercooled Tuner Kit with P-1SC-1	specify	specify	3 Core	\$8,249
2012-14	1DI314-SCI	High Output Intercooled System with P-1SC-1	7 psi	200+ hp	3 Core	\$8,399
2012-14	1DI304-SCI	High Output Intercooled Tuner Kit with P-1SC-1	specify	specify	3 Core	\$7,149

**2011-23 DODGE CHARGER HEMI (5.7) SYSTEMS AND KITS**

Year	Part Number	Description	Boost Options	HP Gain	Intercooler	Price/MAP
2015-23	1DI615-SCI	High Output Intercooled System with P-1SC-1	7 psi	160+ hp	3 Core	\$8,399
2015-23	1DI605-SCI	High Output Intercooled Tuner Kit with P-1SC-1	specify	specify	3 Core	\$7,149
2011-14	1DI414-SCI	High Output Intercooled System with P-1SC-1	7 psi	160+ hp	3 Core	\$8,099
2011-14	1DI404-SCI	High Output Intercooled Tuner Kit with P-1SC-1	specify	specify	3 Core	\$7,149

<b>2011-23 CHARGER (6.4, 5.7) OPTIONS</b>	add "-B" or "-P" to part #	Black or Polished finish for ProCharger (P-series or D-series)	satin standard	-	-	+\$325
	add "-B" or "-P" to part #	Black or Polished finish for ProCharger (F-series, 9" housing)	satin standard	-	-	+\$350
	add "-BB" or "-PB" to part #	Black or Polished finish for supercharger bracket	satin standard	-	-	+\$275
	add "-BI" to part #	Black finish for Intercooler (Race Intercooler Only)	satin standard	-	-	+\$175
	add "-H" to part #	Helical gearset for noise reduction (P-1SC-1, P-1X, D-1SC, D-1X)	same	same	-	+\$110
	add "-P1X" to part #	With P-1X ProCharger (replacing P-1SC-1, Systems and Tuner Kits)	same	add'l 10-15+ hp	-	+\$250
	add "-D1SC" to part #	With D-1SC ProCharger (replacing P-1SC-1)	tuner kit only	specify	-	+\$275
	add "-D1X" to part #	With D-1X ProCharger (replacing P-1SC-1, Tuner Kits only)	tuner kit only	specify	-	+\$475
	add "-D" or "-1" or "-A"	With F-1D, F-1, F-1A ProCharger (replacing P-1SC-1)	tuner kit only	specify	-	+\$875
	add "-94" to part #	With F-1A-94 ProCharger (replacing P-1SC-1)	tuner kit only	specify	-	+\$1,225
	add "-RVR" or "RVB"	Race Bypass Valve Upgrade (specify open or closed valve, Tuner Kits only)	red or black	specify	-	+\$295
	add "-Race" to part #	Air-to-Air Race intercooler upgrade	from 3 core	1000 hp max	-	+\$435
add "-ATIPP" to part #	ATI Balancer Upgrade (6.4 Stage II Systems and Tuner Kits only)	-	-	-	+\$525	
add "-MS" to part #	MAP sensor adaptor bag	tuner kit only	same	-	+\$199	
add "-FP" to part #	In-Tank Fuel Pump	tuner kit only	same	-	+\$550	

**2015-22 DODGE CHARGER V6 (3.6) SYSTEMS AND KITS**

Year	Part Number	Description	Boost Options	HP Gain	Intercooler	Price/MAP
2015-22	1DQ314-SCI	High Output Intercooled System with P-1SC-1	7 psi	40-45%+	3 Core	call
2015-22	1DQ304-SCI	High Output Intercooled Tuner Kit with P-1SC-1	specify	specify	3 Core	call

<b>2015-22 CHARGER V6 OPTIONS</b>	add "-B" or "-P" to part #	Black or Polished finish for ProCharger (P-series or D-series)	satin standard	-	-	+\$325
	add "-B" or "-P" to part #	Black or Polished finish for ProCharger (F-series, 9" housing)	satin standard	-	-	+\$350
	add "-BB" or "-PB" to part #	Black or Polished finish for supercharger bracket	satin standard	-	-	+\$275
	add "-H" to part #	Helical gearset for noise reduction (P-1SC-1, P-1X, D-1SC, D-1X)	same	same	-	+\$110
	add "-P1X" to part #	With P-1X ProCharger (replacing P-1SC-1, Systems and Tuner Kits)	same	add'l 10-15+ hp	-	+\$250
	add "-D1SC" to part #	With D-1SC ProCharger (replacing P-1SC-1)	tuner kit only	specify	-	+\$275
	add "-D1X" to part #	With D-1X ProCharger (replacing P-1SC-1, Tuner Kits only)	tuner kit only	specify	-	+\$475
	add "-D" or "-1" or "-A"	With F-1D, F-1, F-1A ProCharger (replacing P-1SC-1)	tuner kit only	specify	-	+\$875
	add "-RVR" or "RVB"	Race Bypass Valve Upgrade (specify open or closed valve, Tuner Kits only)	red or black	specify	-	+\$295
	add "-MS" to part #	MAP sensor adaptor bag	tuner kit only	same	-	+\$199



# SPECIFICATIONS (2011-23 CHARGER)

## 2012-23 DODGE CHARGER HEMI SRT8 (6.4) SPECIFICATIONS

Year	Part Number	OEM hp Rating	HP Gain	Tube Diam	Intercooler Mount	Drive System	Bypass System	Fuel System Upgrade	Fuel Inj. Supplied	Computer/Ignition Modifications	SC Warranty (in months)	CARB E.O.	Foot Notes
2015-23	1DI515-SCI	485	200+/215+* hp	3"	V	stk 6 rib	ProFlow	MAP sensor, pump/booster	52 lbs/hr	programmer supplied	12, 36 opt. (\$99)	D-365-26(15-20)	X1, X3, X4, X5, X7
2015-23	1DI505-SCI	485	specify	3"	V	stk 6 rib	ProFlow	not supplied	No	not supplied	12	-	X1, X3, X4, X5
2015-19	1DI415-SCI	485	200+/215+* hp	3"	V	add'l 8 rib	ProFlow	MAP sensor, pump/booster	52 lbs/hr	programmer supplied	12, 36 opt. (\$99)	-	X1, X2, X3, X4, X5, X6, X7
2015-19	1DI405-SCI	485	specify	3"	V	add'l 8 rib	ProFlow	not supplied	No	not supplied	12	-	X1, X3, X4, X6
2012-14	1DI314-SCI	470	200+ hp	3"	V	stk 6 rib	ProFlow	MAP sensor, in-tank pump	52 lbs/hr	programmer supplied	12, 36 opt. (\$99)	D-365-22	X1, X3, X4
2012-14	1DI304-SCI	470	specify	3"	V	stk 6 rib	ProFlow	not supplied	No	not supplied	12	-	X1, X3, X4

## 2011-23 DODGE CHARGER HEMI R/T (5.7) SPECIFICATIONS

Year	Part Number	OEM hp Rating	HP Gain	Tube Diam	Intercooler Mount	Drive System	Bypass System	Fuel System Upgrade	Fuel Inj. Supplied	Computer/Ignition Modifications	SC Warranty (in months)	CARB E.O.	Foot Notes
2015-23	1DI615-SCI	375	160+ hp	3"	V	stk 6 rib	ProFlow	MAP sensor, in-tank pump	39.5 lbs/hr	programmer supplied	12, 36 opt. (\$99)	D-365-22 (15-19)	X1, X3, X4, X5
2015-23	1DI605-SCI	375	specify	3"	V	stk 6 rib	ProFlow	not supplied	No	not supplied	12	-	X1, X3, X4, X5
2011-14	1DI414-SCI	370	160+ hp	3"	V	stk 6 rib	ProFlow	MAP sensor	39.5 lbs/hr	programmer supplied	12, 36 opt. (\$99)	D-365-22	X1, X3, X4
2011-14	1DI404-SCI	370	specify	3"	V	stk 6 rib	ProFlow	not supplied	No	not supplied	12	-	X1, X3, X4

## 2015-22 DODGE CHARGER V6 (3.6) SPECIFICATIONS

Year	Part Number	OEM hp Rating	HP Gain	Tube Diam	Intercooler Mount	Drive System	Bypass System	Fuel System Upgrade	Fuel Inj. Supplied	Computer/Ignition Modifications	SC Warranty (in months)	CARB E.O.	Foot Notes
2015-22	1DQ314-SCI	305	40-45%+ hp	3"	V	add'l 6 rib	ProFlow	MAP sensor	50 lb/hr	programmer supplied	12, 36 opt. (\$99)	-	TBD
2015-22	1DQ304-SCI	305	specify	3"	V	add'l 6 rib	ProFlow	not supplied	No	not supplied	12	-	TBD

\* 215+ hp with HO Intercooled System and Race intercooler upgrade

## DODGE AUTOMOTIVE FOOTNOTES (specific to above applications):

- X1) Model year must be specified
- X2) Due to variability among OEM computers, the prevalence of custom modifications, and age/miles/condition of vehicles, dyno tuning may be required
- X3) Systems ship in extra large box
- X4) 2WD models only; AWD models must use Tuner Kit and may require modifications
- X5) 2015+ vehicles may require ECM unlock (call for details)
- X6) Purchase of aftermarket balancer required, ATI PP part #918459 (not included - specify hardened hub)
- X7) 2015-20 supplied with in-tank pump, 2021+ supplied with fuel pump booster



CONTACT US AT (913) 338-2886 OR LEARN MORE AT PROCHARGER.COM

**2006-10 DODGE CHARGER HEMI SRT8 (6.1) SYSTEMS AND KITS**

Year	Part Number	Description	Boost Options	HP Gain	Intercooler	Price/MAP
2006-10	1DD314-SCI-6.1	High Output Intercooled System with P-1SC-1	7 psi	160+ hp	3 Core	\$7,999
2006-10	1DD304-SCI-6.1	High Output Intercooled Tuner Kit with P-1SC-1	specify	specify	3 Core	\$6,799
2006-10	1DD214-SCI-6.1	Stage II Intercooled System with P-1SC-1	7 psi	160+ hp	3 Core	\$9,199
2006-10	1DD204-SCI-6.1	Stage II Intercooled Tuner Kit with P-1SC-1	specify	specify	3 Core	\$7,999

<b>2006-10 CHARGER (6.1) OPTIONS</b>	add "-B" or "-P" to part #	Black or Polished finish for ProCharger (P-series or D-series)	satin standard	-	-	+\$325
	add "-B" or "-P" to part #	Black or Polished finish for ProCharger (F-series, 9" housing)	satin standard	-	-	+\$350
	add "-PHO" to part #	Polished finish for HO supercharger bracket	satin standard	-	-	+\$275
	add "-PST" to part #	Polished finish for Stage II supercharger bracket	satin standard	-	-	+\$325
	add "-H" to part #	Helical gearset for noise reduction (P-1SC-1, P-1X, D-1SC, D-1X)	same	same	-	+\$110
	add "-P1X" to part #	With P-1X ProCharger (replacing P-1SC-1, Systems and Tuner Kits)	same	add'l 10-15+ hp	-	+\$250
	add "-D1SC" to part #	With D-1SC ProCharger (replacing P-1SC-1)	tuner kit only	specify	-	+\$275
	add "-D1X" to part #	With D-1X ProCharger (replacing P-1SC-1, Tuner Kits only)	tuner kit only	specify	-	+\$475
	add "-D" or "-1" or "-A"	With F-1D, F-1, F-1A ProCharger (replacing P-1SC-1, Stage II only)	tuner kit only	specify	-	+\$875
	add "-RVR" or "RVB"	Race Bypass Valve Upgrade (specify open or closed valve, Stage II only)	red or black	specify	-	+\$295
	add "-BU" to part #	Stage II belt upgrade (time of purchase, required for F-series models)	-	-	-	+\$75
add "-MS" to part #	MAP sensor adaptor bag	tuner kit only	same	-	+\$199	
add "-FP" to part #	In-Tank Fuel Pump	tuner kit only	same	-	+\$550	

**2006-10 DODGE CHARGER HEMI R/T (5.7) SYSTEMS AND KITS**

Year	Part Number	Description	Boost Options	HP Gain	Intercooler	Price/MAP
2006-10	1DD314-SCI-5.7	High Output Intercooled System with P-1SC-1	7 psi	110+/130+* hp	3 Core	\$7,699
2006-10	1DD304-SCI-5.7	High Output Intercooled Tuner Kit with P-1SC-1	specify	specify	3 Core	\$6,749
2006-08	1DD214-SCI-5.7	Stage II Intercooled System with P-1SC-1	7 psi	110+ hp	3 Core	\$8,899
2006-08	1DD204-SCI-5.7	Stage II Intercooled Tuner Kit with P-1SC-1	specify	specify	3 Core	\$7,899

<b>2006-10 CHARGER (5.7) OPTIONS</b>	add "-B" or "-P" to part #	Black or Polished finish for ProCharger (P-series or D-series)	satin standard	-	-	+\$325
	add "-B" or "-P" to part #	Black or Polished finish for ProCharger (F-series, 9" housing)	satin standard	-	-	+\$350
	add "-PHO" to part #	Polished finish for HO supercharger bracket	satin standard	-	-	+\$275
	add "-PST" to part #	Polished finish for Stage II supercharger bracket	satin standard	-	-	+\$325
	add "-H" to part #	Helical gearset for noise reduction (P-1SC-1, P-1X, D-1SC, D-1X)	same	same	-	+\$110
	add "-P1X" to part #	With P-1X ProCharger (replacing P-1SC-1, Systems and Tuner Kits)	same	add'l 10-15+ hp	-	+\$250
	add "-D1SC" to part #	With D-1SC ProCharger (replacing P-1SC-1)	tuner kit only	specify	-	+\$275
	add "-D1X" to part #	With D-1X ProCharger (replacing P-1SC-1, Tuner Kits only)	tuner kit only	specify	-	+\$475
	add "-D" or "-1" or "-A"	With F-1D, F-1, F-1A ProCharger (replacing P-1SC-1, Stage II only)	tuner kit only	specify	-	+\$875
	add "-RVR" or "RVB"	Race Bypass Valve Upgrade (specify open or closed valve, Tuner Kits only)	red or black	specify	-	+\$295
	add "-BU" to part #	Stage II belt upgrade (time of purchase, required for F-series models)	-	-	-	+\$75

# SPECIFICATIONS (2006-10 CHARGER)

## 2006-10 DODGE CHARGER HEMI SRT8 (6.1) SPECIFICATIONS

Year	Part Number	OEM hp Rating	HP Gain	Tube Diam	IC Mount	Drive System	Bypass System	Fuel System Upgrade	Fuel Inj. Supplied	Computer/Ignition Modifications	SC Warranty (in months)	CARB E.O.	Foot Notes
2006-10	1DD314-SCI-6.1	425	160+ hp	3"	V	stk 6 rib	ProFlow	MAP sensor, in-tank pump	39.5 lbs/hr	programmer supplied	12, 36 opt. (\$99)	D-365-7	Y1, Y3, Y4, Y6
2006-10	1DD304-SCI-6.1	425	specify	3"	V	stk 6 rib	ProFlow	not supplied	No	not supplied	12	-	Y1, Y3, Y4, Y6
2006-10	1DD214-SCI-6.1	425	160+ hp	3"	V	add'l 8 rib	ProFlow	MAP sensor, in-tank pump	39.5 lbs/hr	programmer supplied	12, 36 opt. (\$99)	-	Y1, Y2, Y3, Y4, Y5, Y6, Y7
2006-10	1DD204-SCI-6.1	425	specify	3"	V	add'l 8 rib	ProFlow	not supplied	No	not supplied	12	-	Y1, Y3, Y4, Y5, Y6, Y7

## 2006-10 DODGE CHARGER HEMI R/T (5.7) SPECIFICATIONS

Year	Part Number	OEM hp Rating	HP Gain	Tube Diam	IC Mount	Drive System	Bypass System	Fuel System Upgrade	Fuel Inj. Supplied	Computer/Ignition Modifications	SC Warranty (in months)	CARB E.O.	Foot Notes
2006-10	1DD314-SCI-5.7	340/370	110+/130+* hp	3"	V	stk 6 rib	ProFlow	MAP sensor	39.5 lbs/hr	programmer supplied	12, 36 opt. (\$99)	D-365-7	Y1, Y3, Y4, Y6
2006-10	1DD304-SCI-5.7	340/370	specify	3"	V	stk 6 rib	ProFlow	not supplied	No	not supplied	12	-	Y1, Y3, Y4, Y6
2006-08	1DD214-SCI-5.7	340	110+ hp	3"	V	add'l 8 rib	ProFlow	MAP sensor	39.5 lbs/hr	programmer supplied	12, 36 opt. (\$99)	-	Y1, Y2, Y3, Y4, Y5, Y6, Y7
2006-08	1DD204-SCI-5.7	340	specify	3"	V	add'l 8 rib	ProFlow	not supplied	No	not supplied	12	-	Y1, Y3, Y4, Y5, Y6, Y7

\* 130+ hp with 2009-10 5.7L VCT engines

### DODGE/AUTOMOTIVE FOOTNOTES (specific to above applications):

- Y1) Model year must be specified
- Y2) Due to variability among OEM computers, the prevalence of custom modifications, and age/miles/condition of vehicles, dyno tuning may be required
- Y3) Specify engine size (5.7 or 6.1)
- Y4) Systems ship in extra large box
- Y5) Purchase of aftermarket balancer required (not included - specify hardened hub):  
5.7 (2006-08) = ATI PP part #918435  
6.1 = ATI PP part #918432
- Y6) 2WD models only; AWD models must use Tuner Kit and may require modifications
- Y7) Special order kit: order form and non-refundable deposit required at time of order—may require additional lead time for processing



CONTACT US AT (913) 338-2886 OR LEARN MORE AT PROCHARGER.COM

**CALL FOR INFO ON 2023 300 (6.4)****2012-14 CHRYSLER 300 HEMI SRT8 (6.4) SYSTEMS AND KITS**

Year	Part Number	Description	Boost Options	HP Gain	Intercooler	Price/MAP
2012-14	1DK314-SCI	High Output Intercooled System with P-1SC-1	7 psi	200+ hp	3 Core	\$8,399
2012-14	1DK304-SCI	High Output Intercooled Tuner Kit with P-1SC-1	specify	specify	3 Core	\$7,149

**2011-23 CHRYSLER 300 HEMI (5.7) SYSTEMS AND KITS**

Year	Part Number	Description	Boost Options	HP Gain	Intercooler	Price/MAP
2015-23	1DK414-SCI	High Output Intercooled System with P-1SC-1	7 psi	160+ hp	3 Core	\$8,399
2015-23	1DK404-SCI	High Output Intercooled Tuner Kit with P-1SC-1	specify	specify	3 Core	\$7,149
2011-14	1DK414-SCI	High Output Intercooled System with P-1SC-1	7 psi	160+ hp	3 Core	\$8,099
2011-14	1DK404-SCI	High Output Intercooled Tuner Kit with P-1SC-1	specify	specify	3 Core	\$7,149

<b>2011-23 300 (6.4, 5.7) OPTIONS</b>	add "-B" or "-P" to part #	Black or Polished finish for ProCharger (P-series or D-series)	satin standard	-	-	+\$325
	add "-B" or "-P" to part #	Black or Polished finish for ProCharger (F-series, 9" housing)	satin standard	-	-	+\$350
	add "-PHO" to part #	Polished finish for supercharger bracket	satin standard	-	-	+\$275
	add "-BB" to part #	Black finish for supercharger bracket	satin standard	-	-	+\$275
	add "-H" to part #	Helical gearset for noise reduction (P-1SC-1, P-1X, D-1SC, D-1X)	same	same	-	+\$110
	add "-P1X" to part #	With P-1X ProCharger (replacing P-1SC-1, Systems and Tuner Kits)	same	add'l 10-15+ hp	-	+\$250
	add "-D1SC" to part #	With D-1SC ProCharger (replacing P-1SC-1)	tuner kit only	specify	-	+\$275
	add "-D1X" to part #	With D-1X ProCharger (replacing P-1SC-1, Tuner Kits only)	tuner kit only	specify	-	+\$475
	add "-D" or "-1" or "-A"	With F-1D, F-1, F-1A ProCharger (replacing P-1SC-1)	tuner kit only	specify	-	+\$875
add "-RVR" or "-RVB"	Race Bypass Valve Upgrade (specify open or closed valve)	red or black	specify	-	+\$295	

**2005-10 CHRYSLER 300 / 2005-08 MAGNUM HEMI (6.1) SYSTEMS AND KITS**

Year	Part Number	Description	Boost Options	HP Gain	Intercooler	Price/MAP
2005-10 (6.1)	1DE314-SCI-6.1	High Output Intercooled System with P-1SC-1	7 psi	160+ hp	3 Core	\$7,999
2005-10 (6.1)	1DE304-SCI-6.1	High Output Intercooled Tuner Kit with P-1SC-1	specify	specify	3 Core	\$6,749

**2005-10 CHRYSLER 300 / 2005-08 MAGNUM HEMI (5.7) SYSTEMS AND KITS**

Year	Part Number	Description	Boost Options	HP Gain	Intercooler	Price/MAP
2005-10 (5.7)	1DE314-SCI-5.7	High Output Intercooled System with P-1SC-1	7 psi	110+/130+* hp	3 Core	\$7,699
2005-10 (5.7)	1DE304-SCI-5.7	High Output Intercooled Tuner Kit with P-1SC-1	specify	specify	3 Core	\$6,749

<b>2005-10 300 (6.1, 5.7) OPTIONS</b>	add "-B" or "-P" to part #	Black or Polished finish for ProCharger (P-series or D-series)	satin standard	-	-	+\$325
	add "-B" or "-P" to part #	Black or Polished finish for ProCharger (F-series, 9" housing)	satin standard	-	-	+\$350
	add "-PHO" to part #	Polished finish for supercharger bracket	satin standard	-	-	+\$275
	add "-H" to part #	Helical gearset for noise reduction (P-1SC-1, P-1X, D-1SC, D-1X)	same	same	-	+\$110
	add "-P1X" to part #	With P-1X ProCharger (replacing P-1SC-1, Systems and Tuner Kits)	same	add'l 10-15+ hp	-	+\$250
	add "-D1SC" to part #	With D-1SC ProCharger (replacing P-1SC-1)	tuner kit only	specify	-	+\$275
	add "-D1X" to part #	With D-1X ProCharger (replacing P-1SC-1, Tuner Kits only)	tuner kit only	specify	-	+\$475
	add "-D" or "-1" or "-A"	With F-1D, F-1, F-1A ProCharger (replacing P-1SC-1)	tuner kit only	specify	-	+\$875
	add "-RVR" or "-RVB"	Race Bypass Valve Upgrade (specify open or closed valve, Tuner Kits only)	red or black	specify	-	+\$295



# SPECIFICATIONS (2005-23 300, MAGNUM)

## 2012-14 CHRYSLER 300 HEMI SRT8 (6.4) SPECIFICATIONS

Year	Part Number	OEM hp Rating	HP Gain	Tube Diam	Intercooler Mount	Drive System	Bypass System	Fuel System Upgrade	Fuel Inj. Supplied	Computer/Ignition Modifications	SC Warranty (in months)	CARB E.O.	Foot Notes
2012-14	1DK314-SCI	470	200+ hp	3"	V	stk 6 rib	ProFlow	MAP sensor, in-tank pump	52 lbs/hr	programmer sup.	12, 36 opt. (\$99)	D-365-22	Z1,Z3, Z4
2012-14	1DK304-SCI	470	specify	3"	V	stk 6 rib	ProFlow	not supplied	No	not supplied	12	-	Z1, Z3, Z4

## 2011-23 CHRYSLER 300 HEMI (5.7) SPECIFICATIONS

Year	Part Number	OEM hp Rating	HP Gain	Tube Diam	Intercooler Mount	Drive System	Bypass System	Fuel System Upgrade	Fuel Inj. Supplied	Computer/Ignition Modifications	SC Warranty (in months)	CARB E.O.	Foot Notes
2015-23	1DK414-SCI	360	160+ hp	3"	V	stk 6 rib	ProFlow	MAP sensor	39.5 lbs/hr	programmer sup.	12, 36 opt. (\$99)	D-365-22 (15-19)	Z1, Z3, Z4, Z6, Z7
2015-23	1DK404-SCI	360	specify	3"	V	stk 6 rib	ProFlow	not supplied	No	not supplied	12	-	Z1, Z3, Z4, Z6, Z7
2011-14	1DK414-SCI	360	160+ hp	3"	V	stk 6 rib	ProFlow	MAP sensor	39.5 lbs/hr	programmer sup.	12, 36 opt. (\$99)	D-365-22 (12-14)	Z1, Z3, Z4, Z6
2011-14	1DK404-SCI	360	specify	3"	V	stk 6 rib	ProFlow	not supplied	No	not supplied	12	-	Z1, Z3, Z4, Z6, Z7

## 2005-10 CHRYSLER 300 / 2005-08 MAGNUM HEMI (6.1) SPECIFICATIONS

Year	Part Number	OEM hp Rating	HP Gain	Tube Diam	Intercooler Mount	Drive System	Bypass System	Fuel System Upgrade	Fuel Inj. Supplied	Computer/Ignition Modifications	SC Warranty (in months)	CARB E.O.	Foot Notes
2005-10 (6.1)	1DE314-SCI-6.1	425	160+ hp	3"	V	stk 6 rib	ProFlow	MAP sensor, in-tank pump	39.5 lbs/hr	programmer sup.	12, 36 opt. (\$99)	D-365-7	Z1, Z3, Z4, Z6, Z8
2005-10 (6.1)	1DE304-SCI-6.1	425	specify	3"	V	stk 6 rib	ProFlow	not supplied	No	not supplied	12	-	Z1, Z3, Z4, Z6, Z8

## 2005-10 CHRYSLER 300 / 2005-08 MAGNUM HEMI (5.7) SPECIFICATIONS

Year	Part Number	OEM hp Rating	HP Gain	Tube Diam	Intercooler Mount	Drive System	Bypass System	Fuel System Upgrade	Fuel Inj. Supplied	Computer/Ignition Modifications	SC Warranty (in months)	CARB E.O.	Foot Notes
2005-10 (5.7)	1DE314-SCI-5.7	340/360	110+/130+* hp	3"	V	stk 6 rib	ProFlow	MAP sensor	39.5 lbs/hr	programmer sup.	12, 36 opt. (\$99)	D-365-7	Z1, Z3, Z4, Z6, Z8
2005-10 (5.7)	1DE304-SCI-5.7	340/360	specify	3"	V	stk 6 rib	ProFlow	not supplied	No	not supplied	12	-	Z1, Z3, Z4, Z6, Z8

\* 130+ hp with 2009-10 5.7L VCT engines

## CHRYSLER AUTOMOTIVE FOOTNOTES (specific to above applications):

- Z1) Model year must be specified
- Z3) Specify engine size (5.7, 6.1, or 6.4)
- Z4) Systems ship in extra large box
- Z6) 2WD models only; AWD models must use Tuner Kit and may require modifications
- Z7) 2015+ vehicles may require ECM unlock (call for details)
- Z8) 2006-10 vehicles require removal of adaptive cruise control sensor



CONTACT US AT (913) 338-2886 OR LEARN MORE AT PROCHARGER.COM

**2019-23 GM TRUCK 1500 (5.3, 6.2) SYSTEMS AND KITS**

Year	Part Number	Description	Boost Options	HP Gain	Intercooler	Price/MAP
2022-23 (5.3)	1KA213-SCI	High Output Intercooled Systems with P-1SC-1 (Global B ECM*)	8 psi	45%+	3 core	\$9,999
2019-23 (5.3)	1KA213-SCI-A	High Output Intercooled Systems with P-1SC-1 (Global A ECM*)	8 psi	45%+	3 core	\$8,999
2019-23 (5.3)	1KA202-SCI	High Output Intercooled Tuner Kit with P-1SC-1	specify	specify	3 core	\$7,999
2022-23 (6.2)	1KA212-SCI	High Output Intercooled Systems with P-1SC-1 (Global B ECM*)	8 psi	45%+	3 core	\$9,999
2019-23 (6.2)	1KA212-SCI-A	High Output Intercooled Systems with P-1SC-1 (Global A ECM*)	8 psi	45%+	3 core	\$8,999
2019-23 (6.2)	1KA202-SCI	High Output Intercooled Tuner Kit with P-1SC-1	specify	specify	3 core	\$7,999
2022-23 (5.3/6.2)	1KA312-SCI	Stage II Intercooled System w/ P-1SC-1 (Global B ECM*)	8 psi	45%+	Stage II	\$10,499
2019-23 (5.3/6.2)	1KA312-SCI-A	Stage II Intercooled System w/ P-1SC-1 (Global A ECM*)	8 psi	45%+	Stage II	\$9,499
2019-23 (5.3/6.2)	1KA302-SCI	Stage II Intercooled Tuner Kit w/ P-1SC-1	specify	specify	Stage II	\$8,499

\* Depends on truck architecture - Global A or Global B. To determine Global A or Global B for GM trucks, please reference the fifth digit of the VIN.

If the fifth digit is 8, 9, W or Y, it is a Global A truck.

If the fifth digit is H, U, A or D, it is a Global B truck.

**\*NEW\* 2021-23 GM SUVs - ESCALADE, TAHOE, SUBURBAN, YUKON, DENALI (5.3, 6.2) SYSTEMS AND KITS**

Year	Part Number	Description	Boost Options	HP Gain	Intercooler	Price/MAP
2021-23 (5.3)	1KB213-SCI	High Output Intercooled Systems with P-1SC-1	8 psi	45%+	3 core	\$9,999
2021-23 (5.3)	1KB202-SCI	High Output Intercooled Tuner Kit with P-1SC-1	specify	specify	3 core	\$7,999
2021-23 (6.2)	1KB212-SCI	High Output Intercooled Systems with P-1SC-1	8 psi	45%+	3 core	\$9,999
2021-23 (6.2)	1KB202-SCI	High Output Intercooled Tuner Kit with P-1SC-1	specify	specify	3 core	\$7,999
2021-23 (5.3/6.2)	1KB312-SCI	Stage II Intercooled System w/ P-1SC-1	8 psi	45%+	Stage II	\$10,499
2021-23 (5.3/6.2)	1KB302-SCI	Stage II Intercooled Tuner Kit w/ P-1SC-1	specify	specify	Stage II	\$8,499

<b>2019-23 GM TRUCK/SUV (5.3, 6.2) OPTIONS</b>	add "-B" or "-P" to part #	Black or Polished finish for ProCharger (P-series or D-series)	sat in standard	-	-	+\$325
	add "-B" or "-P" to part #	Black or Polished finish for ProCharger (F-series, 9" or 9.75" housing)	sat in standard	-	-	+\$350
	add "-BB" or "-PB" to part #	Black or Polished finish for supercharger bracket	sat in standard	-	-	+\$275
	add "-H" to part #	Helical gears for noise reduction (P-1SC-1, P-1X, D-1SC, D-1X)	same	same	-	+\$110
	add "-P1X" to part #	With P-1X ProCharger (replacing P-1SC-1, Systems and Tuner Kits)	same	add'l 10-15+ hp	-	+\$250
	add "-D1SC" to part #	With D-1SC ProCharger (replacing P-1SC-1)	tuner kit only	specify	-	+\$275
	add "-D1X" to part #	With D-1X ProCharger (replacing P-1SC-1, Tuner Kits only)	tuner kit only	specify	-	+\$475
	add "-SII" to part #	Stage II Intercooler Option	from HO	950 hp max	-	+\$435
	add "-AIR" to part #	Stage II Air Inlet Option	from HO	-	-	+\$110
	add "-D" or "-1" or "-A"	With F-1D, F-1, F-1A ProCharger (replacing P-1SC-1)	tuner kit only	specify	-	+\$875
add "-94"	With F-1A-94 (replacing P-1SC-1, Stage II only)	tuner kit only	-	-	+\$1,225	

**2020-23 GM TRUCK 2500 (6.6) SYSTEMS AND KITS**

Year	Part Number	Description	Boost Options	HP Gain	Intercooler	Price/MAP
2020-23 (6.6)	1KA314-SCI	High Output Intercooled Systems with P-1SC-1	call	call	3 core	call
2020-23 (6.6)	1KA304-SCI	High Output Intercooled Tuner Kit with P-1SC-1	specify	specify	3 core	call

# SPECIFICATIONS (2019-23 CHEVROLET/GMC/CADILLAC TRUCK/SUV)

## 2019-23 GM TRUCK 1500 (5.3, 6.2) SPECIFICATIONS

Year	Part Number	OE hp/TQ Rating	HP Gain	Tube Diam	IC Mount	Drive System	Bypass System	Fuel System Upgrade	Fuel Inj. Supplied	Computer/Ignition Modifications	SC Warranty (in months)	CARB E.O.	Foot Notes
2019-23 (5.3)	1KA213-SCI	355/383	45%+	3"	V	add'l 8 rib	Bullet	not required	not required	programmer sup.	12, 36 opt. (\$99)	D-365-28 (19-20)	BA: 1,2,4,5,6,8
2019-23 (5.3)	1KA202-SCI	355/383	specify	3"	V	add'l 8 rib	Bullet	not supplied	No	not supplied	12	-	BA: 1,2,5
2019-23 (6.2)	1KA212-SCI	420/460	45%+	3"	V	add'l 8 rib	Bullet	not required	not required	programmer sup.	12, 36 opt. (\$99)	D-365-28 (19-20)	BA: 1,2,4,5,6,8
2019-23 (6.2)	1KA202-SCI	420/460	specify	3"	V	add'l 8 rib	Bullet	not supplied	No	not supplied	12	-	BA: 1,2,5
2019-23 (5.3/6.2)	1KA312-SCI	420/460	45%+	3"	V	add'l 8 rib	Bullet	not required	not required	programmer sup.	12, 36 opt. (\$99)	-	BA: 1,2,4,5,6,8
2019-23 (5.3/6.2)	1KA302-SCI	420/460	specify	3"	V	add'l 8 rib	Bullet	not supplied	No	not supplied	12	-	BA: 1,2,5

## \*NEW\* 2021-23 GM SUVs - ESCALADE, TAHOE, SUBURBAN, YUKON, DENALI (5.3, 6.2) SPECIFICATIONS

Year	Part Number	OE hp/TQ Rating	HP Gain	Tube Diam	IC Mount	Drive System	Bypass System	Fuel System Upgrade	Fuel Inj. Supplied	Computer/Ignition Modifications	SC Warranty (in months)	CARB E.O.	Foot Notes
2021-23 (5.3)	1KB213-SCI	355/383	45%+	3"	V	add'l 8 rib	Bullet	not required	not required	programmer sup.	12, 36 opt. (\$99)	-	BA: 1,2,3,5,8
2021-23 (5.3)	1KB202-SCI	355/383	specify	3"	V	add'l 8 rib	Bullet	not supplied	No	not supplied	12	-	BA: 1,2,3,5
2021-23 (6.2)	1KB212-SCI	420/460	45%+	3"	V	add'l 8 rib	Bullet	not required	not required	programmer sup.	12, 36 opt. (\$99)	-	BA: 1,2,3,5,8
2021-23 (6.2)	1KB202-SCI	420/460	specify	3"	V	add'l 8 rib	Bullet	not supplied	No	not supplied	12	-	BA: 1,2,3,5
2021-23 (5.3/6.2)	1KB312-SCI	see above	45%+	3"	V	add'l 8 rib	Bullet	not required	not required	programmer sup.	12, 36 opt. (\$99)	-	BA: 1,2,3,5,6,8
2021-23 (5.3/6.2)	1KB302-SCI	see above	specify	3"	V	add'l 8 rib	Bullet	not supplied	No	not supplied	12	-	BA: 1,2,3,5

## 2020-23 GM TRUCK 2500 (6.6) SPECIFICATIONS

Year	Part Number	OE hp/TQ Rating	HP Gain	Tube Diam	IC Mount	Drive System	Bypass System	Fuel System Upgrade	Fuel Inj. Supplied	Computer/Ignition Modifications	SC Warranty (in months)	CARB E.O.	Foot Notes
2020-23 (6.6)	1KA314-SCI	401/464	call	3"	TBD	TBD	TBD	not required	not required	programmer sup.	12, 36 opt. (\$99)	-	TBD
2020-23 (6.6)	1KA304-SCI	401/464	specify	3"	TBD	TBD	TBD	not supplied	No	not supplied	12	-	TBD

### CHEVY TRUCK/SUV FOOTNOTES (specific to above applications):

- BA1) Model year must be specified
- BA2) Specify 2WD or 4WD, Truck or SUV, and GMC or Chevrolet
- BA3) Specify engine size
- BA4) For Flex Fuel vehicles, gasoline-only tune provided, not E85
- BA5) Due to the wide variance of chassis and options available, modifications may be required
- BA6) Due to variability among OEM computers, the prevalence of custom modifications, and age/miles/condition of vehicles, dyno tuning may be required
- BA8) PCM removal and shipment required for all



CONTACT US AT (913) 338-2886 OR LEARN MORE AT PROCHARGER.COM



**2014-18 GM TRUCK 1500 (5.3, 6.2) SYSTEMS AND KITS**

Year	Part Number	Description	Boost Options	HP Gain	Intercooler	Price/MAP
2014-18 (5.3)	1GV213-SCI	High Output Intercooled System with P-1SC-1	8 psi	45%+	3 core	\$7,599
2014-18 (5.3)	1GV202-SCI	High Output Intercooled Tuner Kit with P-1SC-1	specify	specify	3 core	\$7,149
2014-18 (6.2)	1GV212-SCI	High Output Intercooled System with P-1SC-1	8 psi	45%+	3 core	\$7,599
2014-18 (6.2)	1GV202-SCI	High Output Intercooled Tuner Kit with P-1SC-1	specify	specify	3 core	\$7,149
2014-18 (5.3/6.2)	1GV312-SCI	Stage II Intercooled System w/ P-1SC-1 (dedicated drive)	8 psi	45%+	3 core	\$8,249
2014-18 (5.3/6.2)	1GV302-SCI	Stage II Intercooled Tuner Kit w/ P-1SC-1 (dedicated drive)	specify	specify	3 core	\$7,899

**2015-20 GM SUV - ESCALADE, TAHOE, SUBURBAN, YUKON, DENALI (5.3, 6.2) SYSTEMS AND KITS**

Year	Part Number	Description	Boost Options	HP Gain	Intercooler	Price/MAP
2015-20 (5.3)	1GV213-SCI	High Output Intercooled System with P-1SC-1	8 psi	45%+	3 core	\$7,599
2015-20 (5.3)	1GV202-SCI	High Output Intercooled Tuner Kit with P-1SC-1	specify	specify	3 core	\$7,098
2015-20 (6.2)	1GV212-SCI	High Output Intercooled System with P-1SC-1	8 psi	45%+	3 core	\$7,599
2015-20 (6.2)	1GV202-SCI	High Output Intercooled Tuner Kit with P-1SC-1	specify	specify	3 core	\$7,098
2015-20 (5.3/6.2)	1GV312-SCI	Stage II Intercooled System w/ P-1SC-1 (dedicated drive)	8 psi	45%+	3 core	\$8,249
2015-20 (5.3/6.2)	1GV302-SCI	Stage II Intercooled Tuner Kit w/ P-1SC-1 (dedicated drive)	specify	specify	3 core	\$7,849

**2015-19 GM TRUCK 2500 (6.0) SYSTEMS AND KITS**

Year	Part Number	Description	Boost Options	HP Gain	Intercooler	Price/MAP
2015-19	1GV314-SCI	High Output Intercooled Systems with P-1SC-1	7-8 psi	45%+	3 core	\$7,699
2015-19	1GV304-SCI	High Output Intercooled Tuner Kit with P-1SC-1	specify	specify	3 core	\$6,649

<b>2014-18 GM TRUCK &amp; 2015-20 SUV &amp; 2015-19 2500 (5.3, 6.0, 6.2) OPTIONS</b>	add "-B" or "-P" to part #	Black or Polished finish for ProCharger (P-series or D-series)	satin standard	-	-	+\$325
	add "-B" or "-P" to part #	Black or Polished finish for ProCharger (F-series, 9" or 9.75" housing)	satin standard	-	-	+\$350
	add "-B" or "-P" to part #	Black or Polished finish for ProCharger (F-series, 10.5" housing)	satin standard	-	-	+\$375
	add "-BB" or "-PB" to part #	Black or Polished finish for supercharger bracket	satin standard	-	-	+\$275
	add "-H" to part #	Helical gearset for noise reduction (P-1SC-1, P-1X, D-1SC, D-1X)	same	same	-	+\$110
	add "-P1X" to part #	With P-1X ProCharger (replacing P-1SC-1, Systems and Tuner Kits)	same	add'l 10-15+ hp	-	+\$250
	add "-D1SC" to part #	With D-1SC ProCharger (replacing P-1SC-1)	tuner kit only	specify	-	+\$275
	add "-D1X" to part #	With D-1X ProCharger (replacing P-1SC-1, Tuner Kits only)	tuner kit only	specify	-	+\$475
	add "-VI" to part #	Vertical Intercooler Option (from 3 core Horizontal)	from horizontal	950 hp max	-	+\$215
	add "-FA" to part #	Forward facing air inlet (rear facing is standard, HO only)	same	same	-	+\$130
	add "-D" or "-1" or "-A"	With F-1D, F-1, F-1A ProCharger (replacing P-1SC-1)	tuner kit only	specify	-	+\$875
	add "-94" or "-C" or "-R"	With F-1A-94, F-1C or F-1R (replacing P-1SC-1, Stage II only)	tuner kit only	-	-	+\$1,225
	add "-F1X" to part #	With F-1X ProCharger (replacing P-1SC-1, Stage II only)	tuner kit only	specify	-	+\$2,030
	add "-RVR" or "RVB"	Race Bypass Valve Upgrade (Stage II only, Tuner Kits only)	red or black	specify	-	+\$295
add "-Race" to part #	Air-to-Air Race Intercooler Upgrade (Stage II Tuner Kit only)	from 3 core	1300 hp max	-	+\$435	



# SPECIFICATIONS (2014-20 CHEVROLET/GMC/CADILLAC TRUCK/SUV)

## 2014-18 GM TRUCK 1500 (5.3, 6.2) SPECIFICATIONS

Year	Part Number	OE hp/TQ Rating	HP Gain	Tube Diam	IC Mount	Drive System	Bypass System	Fuel System Upgrade	Fuel Inj. Supplied	Computer/Ignition Modifications	SC Warranty (in months)	CARB E.O.	Foot Notes
2014-18 (5.3)	1GV213-SCI	355/383	45%+	3"	H / V	stk 6 rib	ProFlow	not required	not required	programmer sup.	12, 36 opt. (\$99)	D-365-28	BB: 1,2,3,5,7,9
2014-18 (5.3)	1GV202-SCI	355/383	specify	3"	H / V	stk 6 rib	ProFlow	not supplied	No	not supplied	12	-	BB: 1,2,3,5,7
2014-18 (6.2)	1GV212-SCI	420/460	45%+	3"	H / V	stk 6 rib	ProFlow	not required	not required	programmer sup.	12, 36 opt. (\$99)	D-365-28	BB: 1,2,3,5,7,9
2014-18 (6.2)	1GV202-SCI	420/460	specify	3"	H / V	stk 6 rib	ProFlow	not supplied	No	not supplied	12	-	BB: 1,2,3,5,7
2014-18 (5.3/6.2)	1GV312-SCI	see above	45%+	3"	H / V	add'l 8 rib	ProFlow	not required	not required	programmer sup.	12, 36 opt. (\$99)	D-365-28	BB: 1,2,3,5,6,7,8,9
2014-18 (5.3/6.2)	1GV302-SCI	see above	specify	3"	H / V	add'l 8 rib	ProFlow	not supplied	No	not supplied	12	-	BB: 1,2,3,5,7,8

## 2015-20 GM SUV - ESCALADE, TAHOE, SUBURBAN, YUKON, DENALI (5.3, 6.2) SPECIFICATIONS

Year	Part Number	OE hp/TQ Rating	HP Gain	Tube Diam	IC Mount	Drive System	Bypass System	Fuel System Upgrade	Fuel Inj. Supplied	Computer/Ignition Modifications	SC Warranty (in months)	CARB E.O.	Foot Notes
2015-20 (5.3)	1GV213-SCI	355/383	45%+	3"	H / V	stk 6 rib	ProFlow	not required	not required	programmer sup.	12, 36 opt. (\$99)	-	BB: 1,2,3,5,7,9
2015-20 (5.3)	1GV202-SCI	355/383	specify	3"	H / V	stk 6 rib	ProFlow	not supplied	No	not supplied	12	-	BB: 1,2,3,5,7
2015-20 (6.2)	1GV212-SCI	420/460	45%+	3"	H / V	stk 6 rib	ProFlow	not required	not required	programmer sup.	12, 36 opt. (\$99)	-	BB: 1,2,3,5,7,9
2015-20 (6.2)	1GV202-SCI	420/460	specify	3"	H / V	stk 6 rib	ProFlow	not supplied	No	not supplied	12	-	BB: 1,2,3,5,7
2015-20 (5.3/6.2)	1GV312-SCI	see above	45%+	3"	H / V	add'l 8 rib	ProFlow	not required	not required	programmer sup.	12, 36 opt. (\$99)	-	BB: 1,2,3,5,6,7,8,9
2015-20 (5.3/6.2)	1GV302-SCI	see above	specify	3"	H / V	add'l 8 rib	ProFlow	not supplied	No	not supplied	12	-	BB: 1,2,3,5,7,8

## 2015-19 GM TRUCK 2500 (6.0) SPECIFICATIONS

Year	Part Number	OE hp/TQ Rating	HP Gain	Tube Diam	IC Mount	Drive System	Bypass System	Fuel System Upgrade	Fuel Inj. Supplied	Computer/Ignition Modifications	SC Warranty (in months)	CARB E.O.	Foot Notes
2015-19	1GV314-SCI	360/380	45%+	3"	V	stk 6 rib	ProFlow	not required	56 lb/hr	programmer sup.	12, 36 opt. (\$99)	-	BB: 1,2,4,5,6,9
2015-19	1GV304-SCI	360/380	specify	3"	V	stk 6 rib	ProFlow	not supplied	No	not supplied	12	-	BB: 1,2,5

### CHEVY TRUCK/SUV FOOTNOTES (specific to above applications):

- BB1) Model year must be specified
- BB2) Specify 2WD or 4WD, Truck or SUV, and GMC or Chevrolet
- BB3) Specify engine size
- BB4) For Flex Fuel vehicles, gasoline-only tune provided, not E85
- BB5) Due to the wide variance of chassis and options available, modifications may be required
- BB6) Due to variability among OEM computers, the prevalence of custom modifications, and age/miles/condition of vehicles, dyno tuning may be required
- BB7) 2017-18 Trucks require vertical intercooler; 2017-18 SUVs require horizontal intercooler
- BB8) Specify stock or aftermarket balancer (IW #760 or ATI #918645 + #916358, specify hardened hub)
- BB9) Due to potential OEM transmissions issues, no TCM changes are included

**2007-13 GM TRUCK 1500 / 2007-14 SUV (4.8, 5.3) SYSTEMS AND KITS (LATE 2007-2013)**

Year	Part Number	Description	Boost Options	HP Gain	Intercooler	Price/MAP
2007-13 (4.8)	1GR212-SCI	High Output Intercooled System with P-1SC-1	8-9 psi	50-55%	2 core	\$7,449
2007-13 (5.3)	1GR212-SCI	High Output Intercooled System with P-1SC-1	8-9 psi	50-55%	2 core	\$7,449
2007-13 (4.8 / 5.3)	1GR202-SCI	High Output Intercooled Tuner Kit with P-1SC-1	specify	specify	2 core	\$6,549
2007-13 (4.8)	1GR312-SCI	Stage II Intercooled System with P-1SC-1 (dedicated drive)	8-9 psi	50-55%	2 core	\$7,999
2007-13 (5.3)	1GR312-SCI	Stage II Intercooled System with P-1SC-1 (dedicated drive)	8-9 psi	50-55%	2 core	\$7,999
2007-13 (4.8 / 5.3)	1GR302-SCI	Stage II Intercooled Tuner Kit with P-1SC-1 (dedicated drive)	specify	specify	2 core	\$7,099

**2007-13 GM TRUCK 1500 / 2007-14 SUV / 2007-11 2500 (6.0, 6.2) SYSTEMS AND KITS**

Year	Part Number	Description	Boost Options	HP Gain	Intercooler	Price/MAP
2007-09 (6.0)	1GR212-SCI	High Output Intercooled System with P-1SC-1	7-8 psi	50%+	3 core	\$7,799
2007-09 (6.0)	1GR202-SCI	High Output Intercooled Tuner Kit with P-1SC-1	specify	specify	3 core	\$6,899
2007-13 (6.2)	1GR213-SCI	High Output Intercooled System with P-1SC-1	7-8 psi	50%+	3 core	\$7,799
2007-13 (6.2)	1GR202-SCI	High Output Intercooled Tuner Kit with P-1SC-1	specify	specify	3 core	\$6,899
2007-13 (6.0 / 6.2)	1GR312-SCI	Stage II Intercooled System w/ P-1SC-1 (dedicated drive)	7-8 psi	50%+	3 core	\$8,299
2007-13 (6.0 / 6.2)	1GR302-SCI	Stage II Intercooled Tuner Kit w/ P-1SC-1 (dedicated drive)	specify	specify	3 core	\$7,299

<b>2007-13 GM TRUCK/SUV (5.3, 6.0, 6.2, 4.8) OPTIONS</b>	add "-B" or "-P" to part #	Black or Polished finish for ProCharger (P-series or D-series)	satin standard	-	-	+\$325
	add "-B" or "-P" to part #	Black or Polished finish for ProCharger (F-series, 9" or 9.75" housing)	satin standard	-	-	+\$350
	add "-B" or "-P" to part #	Black or Polished finish for ProCharger (F-series, 10.5" housing)	satin standard	-	-	+\$375
	add "-B" or "-P" to part #	Black or Polished finish for ProCharger (F-series, 12" housing)	satin standard	-	-	+\$425
	add "-BB" or "-PB" to part #	Black or Polished finish for supercharger bracket	satin standard	-	-	+\$275
	add "-H" to part #	Helical gearset for noise reduction (P-1SC-1, P-1X, D-1SC, D-1X)	same	same	-	+\$110
	Add "-10R" to part #	10 Rib Belt Drive Upgrade	tuner kit only	-	-	+\$260
	add "-P1X" to part #	With P-1X ProCharger (replacing P-1SC-1, Systems and Tuner Kits)	same	add'l 10-15+ hp	-	+\$250
	add "-D1SC" to part #	With D-1SC ProCharger (replacing P-1SC-1)	tuner kit only	specify	-	+\$275
	add "-D1X" to part #	With D-1X ProCharger (replacing P-1SC-1, Tuner Kits only)	tuner kit only	specify	-	+\$475
	add "-D" or "-1" or "-A"	With F-1D, F-1, F-1A ProCharger (replacing P-1SC-1)	tuner kit only	specify	-	+\$875
	add "-94" to part #	With F-1A-94 ProCharger (replacing P-1SC-1)	tuner kit only	specify	-	+\$1,225
	add "-C" or "-R" to part #	With F-1C, or F-1R ProCharger (replacing P-1SC-1, Stage II Kits only)	tuner kit only	specify	-	+\$1,225
	add "-F2" to part #	With F-1X ProCharger (replacing P-1SC-1, Stage II Kits only)	tuner kit only	specify	-	+\$2,030
	add "-RVR" or "RVB"	Race Bypass Valve Upgrade (specify open or closed valve)	red or black	specify	-	+\$295
	add "-FA" to part #	Forward facing air inlet (Stage II only)	rear facing std	same	-	+\$130
add "-VI" to part #	Vertical Intercooler (from 3 core Horizontal, may require trimmming)	from horizontal	950 hp max	-	+\$215	
add "-3C" to part #	3 core intercooler system upgrade	from 2 core	825 hp max	3" tubing	+\$435	
	3GKMM-004	Crank Pin Kit	-	-	-	+\$109

**2007-13 GM TRUCK/SUV 1500/2500 (4.8, 5.3, 6.0, 6.2) i-1 PROGRAMMABLE RATIO SYSTEMS**

Year	Part Number	Description	Boost Options	HP Gain	Intercooler	Price/MAP
2007-13 (4.8)	1GR215-SCI	High Output Intercooled System with i-1	8-9 psi	55-60%+	3 core	\$10,399
2007-13 (5.3)	1GR215-SCI	High Output Intercooled System with i-1	8-9 psi	55-60%+	3 core	\$10,399
2007-13 (6.0)	1GR215-SCI	High Output Intercooled System with i-1	7-8 psi	50-55%+	3 core	\$10,399
2007-13 (6.2)	1GR215-SCI	High Output Intercooled System with i-1	7-8 psi	50-55%+	3 core	\$10,399

<b>GM TRUCK/SUV I-1 OPTIONS</b>	add "-T" to part #	Touchscreen (at time of system purchase)	-	-	-	+\$395
	add "-V" to part #	Vertical Intercooler Option (from 3 Core Horizontal)	from horizontal	900 hp max	-	+\$215
	add "-P" to part #	Polished finish (supercharger and bracket)	satin standard	-	-	+\$595
	add "-B" to part #	Black finish (supercharger and bracket)	satin standard	-	-	+\$795

# SPECIFICATIONS (2007-13 CHEVROLET/GMC/CADILLAC TRUCK/SUV)

## 2007-13 GM TRUCK 1500 / 2007-14 SUV (4.8, 5.3) (LATE 2007-2013) SPECIFICATIONS

Year	Part Number	OE hp/TQ Rating	HP Gain	Tube Diam	IC Mount	Drive System	Bypass System	Fuel System Upgrade	Fuel Inj. Supplied	Computer/Ignition Modifications	SC Warranty (in months)	CARB E.O.	Foot Notes
2007-13 (4.8)	1GR212-SCI	295/305	50-55%	3"	H	stk 6 rib	ProFlow	not required	52 lb/hr	programmer sup.	12, 36 opt. (\$99)	D-365-10	CC: 1, 2, 3, 5, 7, 9
2007-13 (5.3)	1GR212-SCI	315/338	50-55%	3"	H	stk 6 rib	ProFlow	not required	52 lb/hr	programmer sup.	12, 36 opt. (\$99)	D-365-10	CC: 1, 2, 3, 4, 5, 7, 9
2007-13 (4.8/5.3)	1GR202-SCI	-	specify	3"	H	stk 6 rib	ProFlow	not supplied	No	not supplied	12	-	CC: 1, 2, 3, 5, 7, 9
2007-13 (4.8)	1GR312-SCI	295/305	50-55%	3"	H	add'l 8 rib	ProFlow	not required	52 lb/hr	programmer sup.	12, 36 opt. (\$99)	-	CC: 1, 2, 3, 5, 6, 7, 9, 10
2007-13 (5.3)	1GR312-SCI	315/338	50-55%	3"	H	add'l 8 rib	ProFlow	not required	52 lb/hr	programmer sup.	12, 36 opt. (\$99)	-	CC: 1, 2, 3, 4, 5, 6, 7, 9, 10
2007-13 (4.8/5.3)	1GR302-SCI	-	specify	3"	H	add'l 8 rib	ProFlow	not supplied	No	not supplied	12	-	CC: 1, 2, 3, 5, 7, 9, 10

## 2007-13 GM TRUCK 1500 / 2007-14 SUV / 2007-11 2500 (6.0, 6.2) SPECIFICATIONS

Year	Part Number	OE hp/TQ Rating	HP Gain	Tube Diam	IC Mount	Drive System	Bypass System	Fuel System Upgrade	Fuel Inj. Supplied	Computer/Ignition Modifications	SC Warranty (in months)	CARB E.O.	Foot Notes
2007-09 (6.0)	1GR212-SCI	367/375	50%+	3"	H	stk 6 rib	ProFlow	pump volt. boost.	52 lb/hr	programmer sup.	12, 36 opt. (\$99)	D-365-10	CC: 1, 2, 3, 4, 5, 7, 8, 9
2007-09 (6.0)	1GR202-SCI	367/375	specify	3"	H	stk 6 rib	ProFlow	not supplied	No	not supplied	12	-	CC: 1, 2, 3, 5, 7, 8, 9
2007-13 (6.2)	1GR213-SCI	380/417	50%+	3"	H	stk 6 rib	ProFlow	pump volt. boost.	65 lb/hr	programmer sup.	12, 36 opt. (\$99)	D-365-10	CC: 1, 2, 3, 4, 5, 7, 9
2007-13 (6.2)	1GR202-SCI	380/417	specify	3"	H	stk 6 rib	ProFlow	not supplied	No	not supplied	12	-	CC: 1, 2, 3, 5, 7, 9
2007-13 (6.0 / 6.2)	1GR312-SCI	-	50%+	3"	H	add'l 8 rib	ProFlow	pump volt. boost.	52/65 lb/hr	programmer sup.	12, 36 opt. (\$99)	-	CC: 1, 2, 3, 4, 5, 6, 7, 9, 10
2007-13 (6.0 / 6.2)	1GR302-SCI	-	specify	3"	H	add'l 8 rib	ProFlow	not supplied	No	not supplied	12	-	CC: 1, 2, 3, 5, 7, 9, 10

## 2007-13 GM TRUCK/SUV 1500/2500 (4.8, 5.3, 6.0, 6.2) i-1 PROGRAMMABLE RATIO SPECIFICATIONS

Year	Part Number	OE hp/TQ Rating	HP Gain	Tube Diam	IC Mount	Drive System	Bypass System	Fuel System Upgrade	Fuel Inj. Supplied	Computer/Ignition Modifications	SC Warranty (in months)	CARB E.O.	Foot Notes
2007-13 (4.8)	1GR215-SCI	295/305	55-60%	3"	H	add'l 8 rib	ProFlow	not required	52 lb/hr	programmer sup.	12, 36 opt. (\$149)	-	CC 1, 2, 3, 5, 6, 9, 11
2007-13 (5.3)	1GR215-SCI	315/338	55-60%	3"	H	add'l 8 rib	ProFlow	not required	52 lb/hr	programmer sup.	12, 36 opt. (\$149)	-	CC 1, 2, 3, 5, 6, 9, 11
2007-13 (6.0)	1GR215-SCI	360/380	50-55%+	3"	H	add'l 8 rib	ProFlow	pump volt. boost.	52 lb/hr	programmer sup.	12, 36 opt. (\$149)	-	CC: 1, 2, 3, 5, 6, 8, 9, 11
2007-13 (6.2)	1GR215-SCI	380/417	50-55%+	3"	H	add'l 8 rib	ProFlow	pump volt. boost.	65 lb/hr	programmer sup.	12, 36 opt. (\$149)	-	CC: 1, 2, 3, 5, 6, 9, 11

### CHEVY TRUCK/SUV FOOTNOTES (specific to above applications):

- CC1) Model year must be specified
- CC2) Specify 2WD or 4WD, Truck or SUV
- CC3) Specify engine size
- CC4) For Flex Fuel vehicles, gasoline-only tune provided, not E85
- CC5) Due to the wide variance of chassis and options available, modifications may be required
- CC6) Due to variability among OEM computers, the prevalence of custom modifications, and age/miles/condition of vehicles, dyno tuning may be required
- CC7) 2007 Classic use 1G1213-SCI (HO Intercooled System) or 1G1203-SCI (HO Intercooled Tuner Kit)
- CC8) HD models with Hydroboost may require modifications to power steering reservoir
- CC9) Pinning the balancer to the crank is recommended; Pin kit for stock balancer not supplied
- CC10) Specify stock or optional ATI Balancer #918635 (not included - specify hardened hub)
- CC11) Special order kit: order form and non-refundable deposit required at time of order—may require additional lead time for processing



CONTACT US AT (913) 338-2886 OR LEARN MORE AT PROCHARGER.COM

**1999-07 GM 1500 CLASSIC TRUCK/SUV (4.8, 5.3, 6.0) SYSTEMS AND KITS**

Year	Part Number	Description	Boost Options	HP Gain	Intercooler	Price/MAP
2003-07 (4.8/5.3)	1GI213-SCI	High Output Intercooled System with P-1SC (4.8 / 5.3)	8-9 psi	60-65%	2 core	\$7,299
2003-07 (6.0)	1GI213-SCI	High Output Intercooled System with P-1SC (6.0)	7-8 psi	55-60%	2 core	\$7,299
2003-07	1GI203-SCI	High Output Intercooled Tuner Kit with P-1SC (4.8 / 5.3 / 6.0)	specify	specify	2 core	\$6,549
1999-03 (4.8/5.3)	1GI212-SCI	High Output Intercooled System with P-1SC (4.8 / 5.3)	8-9 psi	60-65%	2 core	\$6,949
1999-03 (6.0)	1GI212-SCI	High Output Intercooled System with P-1SC (6.0)	7-8 psi	55-60%	2 core	\$6,949
1999-03	1GI202-SCI	High Output Intercooled Tuner Kit with P-1SC (4.8 / 5.3 / 6.0)	specify	specify	2 core	\$6,599
1999-07 (4.8/5.3)	<b>*NEW*</b> 1GI512-SCI	Stage II Intercooled System with P-1SC-1 (4.8 / 5.3) (dedicated drive)	8-9 psi	60-65%	3 core	\$7,999
1999-07 (6.0)	<b>*NEW*</b> 1GI512-SCI	Stage II Intercooled System with P-1SC-1 (6.0) (dedicated drive)	7-8 psi	55-60%	3 core	\$7,999
1999-07	<b>*NEW*</b> 1GI502-SCI	Stage II Intercooled Tuner Kit with P-1SC-1 (4.8 / 5.3 / 6.0) (dedicated drive)	specify	specify	3 core	\$7,549

**1999-07 GM 2500 CLASSIC TRUCK (6.0) KITS**

Year	Part Number	Description	Boost Options	HP Gain	Intercooler	Price/MAP
1999-07 (6.0)	1GI304-SCI	High Output Intercooled Tuner Kit with P-1SC-1	specify	specify	3 core	\$6,999
2004-07 (6.0)	1GI404-SCI	Stage II Intercooled Tuner Kit with P-1SC-1	specify	specify	3 core	\$7,399

**2003-09 HUMMER H2 (6.0, 6.2) TUNER KITS**

Year	Part Number	Description	Boost Options	HP Gain	Intercooler	Price/MAP
2008-09 (6.2)	1GL302-SCI	High Output Intercooled Tuner Kit with P-1SC-1 (6.2)	specify	specify	H2	\$6,899
2003-07 (6.0)	1GL202-SCI	High Output Intercooled Tuner Kit with P-1SC (6.0)	specify	specify	H2	\$6,849

<b>1999-07 GM TRUCK/SUV, HUMMER H2 (5.3, 6.0, 6.2, 4.8) OPTIONS</b>	add "-B" or "-P" to part #	Black or Polished finish for ProCharger (P-series or D-series)	head unit only	-	-	+\$325
	add "-PB" to part #	Polished finish for supercharger bracket	satin standard	-	-	+\$275
	add "-3C" to part #	3 core intercooler system upgrade (GM Truck/SUV only)	from 2 core	825 hp max	3" tubing	+\$435
	add "-VI" to part #	Vertical intercooler system upgrade (2004-07 2500 only)	from 2 core	825 hp max	3" tubing	+\$435
	add "-H" to part #	Helical gearset for noise reduction (P-1SC, P-1SC-1, D-1SC)	same	same	-	+\$110
	Add "-10R" to part #	10 Rib Belt Drive Upgrade	tuner kit only	-	-	+\$120
	add "-D1SC" to part #	With D-1SC ProCharger (replacing P-1SC)	tuner kit only	specify	-	+\$495
	add "-D1SC" to part #	With D-1SC ProCharger (replacing P-1SC-1)	tuner kit only	-	-	+\$275
	add "-D" or "-1" or "-A"	With F-1D, F-1, F-1A ProCharger (replacing P-1SC-1)	tuner kit only	specify	-	+\$875
	add "-94" to part #	With F-1A-94 ProCharger (replacing P-1SC-1 - Stage II Kits only)	tuner kit only	specify	-	+\$1,225
	add "-F2" to part #	With F-1X ProCharger (replacing P-1SC-1, Stage II Kits only)	tuner kit only	specify	-	+\$2,030
3GKMM-004	Crank Pin Kit	-	-	-	+\$109	



# SPECIFICATIONS (1999-2007 CHEVROLET/GMC/CADILLAC/H2 TRUCK/SUV)

## 1999-07 GM 1500 CLASSIC TRUCK/SUV (4.8, 5.3, 6.0) SPECIFICATIONS

Year	Part Number	OEM hp/TQ Rating	HP Gain	Tube Diam	IC Mount	Drive System	Bypass System	Fuel System Upgrade	Fuel Inj. Supplied	Computer/Ignition Modifications	SC Warranty (in months)	CARB E.O.	Foot Notes
2003-07 (4.8/5.3)	1GI213-SCI	285/325	60-65%	3"	H	stk 6 rib	ProFlow	not req'd	49 lb/hr	programmer sup.	12, 36 opt. (\$99)	-	DA: 1, 2, 3, 4, 5, 7, 8, 9
2003-07 (6.0)	1GI213-SCI	320/360	55-60%	3"	H	stk 6 rib	ProFlow	not req'd	49 lb/hr	programmer sup.	12, 36 opt. (\$99)	-	DA: 1, 2, 4, 5, 7, 8, 9
2003-07	1GI203-SCI	-	specify	3"	H	stk 6 rib	ProFlow	not supplied	not supp'd	not supplied	12	-	DA: 1, 2, 4, 5, 7, 9, 10
1999-03 (4.8/5.3)	1GI212-SCI	285/325	60-65%	3"	H	stk 6 rib	ProFlow	ProPump, FMU	not req'd	not required	12, 36 opt. (\$99)	D-365-10	DA: 1, 2, 3, 4, 5, 7, 9
1999-03 (6.0)	1GI212-SCI	320/360	55-60%	3"	H	stk 6 rib	ProFlow	ProPump, FMU	not req'd	not required	12, 36 opt. (\$99)	D-365-10	DA: 1, 2, 3, 4, 5, 7, 9
1999-03	1GI202-SCI	-	specify	3"	H	stk 6 rib	ProFlow	not supplied	not supp'd	not supplied	12	-	DA: 1, 2, 4, 5, 7, 9, 10
1999-07 (4.8/5.3)	1GI512-SCI	285/325	60-65%	3"	V	add'l 8 rib	ProFlow	not req'd	49 lb/hr	programmer sup.	12, 36 opt. (\$99)	-	DA: 1, 2, 3, 4, 5, 7, 8, 9, 10, 12
1999-07 (6.0)	1GI512-SCI	320/360	55-60%	3"	V	add'l 8 rib	ProFlow	not req'd	49 lb/hr	programmer sup.	12, 36 opt. (\$99)	-	DA: 1, 2, 4, 5, 7, 8, 9, 10, 12
1999-07	1GI502-SCI	-	specify	3"	V	add'l 8 rib	ProFlow	not supplied	not supp'd	not supplied	12	-	DA: 1, 2, 4, 5, 7, 9, 10, 12

## 1999-07 GM 2500 CLASSIC TRUCK (6.0) SPECIFICATIONS

Year	Part Number	OEM hp/TQ Rating	HP Gain	Tube Diam	IC Mount	Drive System	Bypass System	Fuel System Upgrade	Fuel Inj. Supplied	Computer/Ignition Modifications	SC Warranty (in months)	CARB E.O.	Foot Notes
1999-07 (6.0)	1GI304-SCI	-	specify	3"	H/V	stk 6 rib	ProFlow	not supplied	not supp'd	not supplied	12	-	DA: 1, 2, 4, 5, 7, 9, 10, 13
1999-07 (6.0)	1GI404-SCI	-	specify	3"	H/V	add'l 8 rib	ProFlow	not supplied	not supp'd	not supplied	12	-	DA: 1, 2, 4, 5, 7, 9, 10, 12, 13

## 2003-09 HUMMER H2 (6.0, 6.2) SPECIFICATIONS

Year	Part Number	OEM hp/TQ Rating	HP Gain	Tube Diam	IC Mount	Drive System	Bypass System	Fuel System Upgrade	Fuel Inj. Supplied	Computer/Ignition Modifications	SC Warranty (in months)	CARB E.O.	Foot Notes
2008-09 (6.2)	1GL302-SCI	393/415	specify	2.5"	V	stk 6 rib	ProFlow	not supplied	No	not supplied	12	-	DA: 9, 10, 11
2003-07 (6.0)	1GL202-SCI	316/360	specify	3"	H	stk 6 rib	ProFlow	none supplied	No	not supplied	12	-	DA: 9, 10, 11

### CHEVY TRUCK/SUV FOOTNOTES (specific to above applications):

- |   |  |
|---|--|
| DA1) Model year must be specified   | DA9) Pinning the balancer to the crank is recommended; Pin kit for stock balancer not supplied   |
| DA2) Specify 2WD or 4WD, Truck or SUV   | DA10) System ships in extra large box  |
| DA3) Specify engine size  | DA11) Special order kit: order form and non-refundable deposit required at time of order—may require additional lead time for processing |
| DA4) Modifications and custom tuning required for HD/2500 Series applications (Tuner Kits only)   | DA12) Electric fan conversion required (sold separately by others)   |
| DA5) Specify if hydroboost option   | DA13) HD models with Hydroboost may require modifications to power steering reservoir  |
| DA7) Due to the wide variance of chassis and options available, modifications may be required   |  |
| DA8) Due to variability among OEM computers, the prevalence of custom modifications, and age/miles/condition of vehicles, dyno tuning may be required |  |

**1996-00 GM TRUCK/SUV (5.7, 7.4) SYSTEMS**

Year	Part Number	Description	Boost Options	HP Gain	Intercooler	Price/MAP
1996-00 (5.7)	1GH212-SCI	High Output Intercooled System with P-1SC (5.7)	8-9 psi	60-65%	2 core	\$6,899
1996-00 (5.7)	1GH202-SCI	High Output Intercooled Tuner Kit with P-1SC (5.7)	specify	specify	2 core	\$6,599
1996-00 (7.4)	1GG202-SCI	High Output Intercooled Tuner Kit with P-1SC (7.4)	specify	specify	2 core	\$6,599

**1988-95 GM TBI TRUCK/SUV (5.7, 7.4) SYSTEMS**

Year	Part Number	Description	Boost Options	HP Gain	Intercooler	Price/MAP
1988-95 (5.7)	1GD212-SCI	High Output Intercooled System with P-1SC (5.7) - without air pump	8-9 psi	60-65%	2 core	\$6,199
1988-95 (5.7)	1GD202-SCI	High Output Intercooled Tuner Kit with P-1SC (5.7)	specify	specify	2 core	\$5,949
1988-95 (5.7)	1GD212-09I	High Output Intercooled System with P600B (5.7) - with air pump	8-9 psi	60-65%	2 core	\$5,899
1988-95 (7.4)	1GE212-SCI	High Output Intercooled System with P-1SC (7.4)	8-9 psi	60-65%	2 core	\$6,199
1988-95 (7.4)	1GE202-SCI	High Output Intercooled Tuner Kit with P-1SC (7.4)	specify	specify	2 core	\$5,949
1988-95 (7.4)	1GE212-09I	High Output Intercooled System with P600B (7.4)	8-9 psi	60-65%	2 core	\$5,899

1988-00 GM TRUCK/SUV (5.7, 7.4)	add "-B" or "-P" to part #	Black or Polished finish for ProCharger (P-series or D-series)	satin standard	-	-	+\$325
	add "-H" to part #	Helical gearset for noise reduction (P-1SC)	same	same	-	+\$110
	add "-D1SC" to part #	With D-1SC ProCharger (replacing P-1SC)	specify	specify	-	+\$495
	add "-D1" to part #	With D-1 ProCharger (replacing P600B, 1988-95 only)	specify	specify	-	+\$895

# SPECIFICATIONS (1988-2000 CHEVROLET/GMC/CADILLAC/H2 TRUCK/SUV)

## 1996-00 GM TRUCK/SUV (5.7, 7.4) SPECIFICATIONS

Year	Part Number	OEM hp/TQ Rating	HP Gain	Tube Diam	IC Mount	Drive System	Bypass System	Fuel System Upgrade	Fuel Inj. Supplied	Computer/Ignition Modifications	SC Warranty (in months)	CARB E.O.	Foot Notes
1996-00 (5.7)	1GH212-SCI	250/335	60-65%	3"	H	stk 6 rib	ProFlow	ProPump, FMU	not req'd	MAF massager	12, 36 opt. (\$99)	D-365-3	DD1, DD2, DD3, DD4
1996-00 (5.7)	1GH202-SCI	250/335	specify	3"	H	stk 6 rib	ProFlow	not supplied	not req'd	not supplied	12	-	DD1, DD2, DD3, DD4
1996-00 (7.4)	1GG202-SCI	290/410	specify	3"	H	stk 6 rib	ProFlow	not supplied	not req'd	not supplied	12	-	DD1, DD2, DD3, DD4

## 1988-95 GM TBI TRUCK/SUV (5.7, 7.4) SPECIFICATIONS

Year	Part Number	OEM hp/TQ Rating	HP Gain	Tube Diam	IC Mount	Drive System	Bypass System	Fuel System Upgrade	Fuel Inj. Supplied	Computer/Ignition Modifications	SC Warranty (in months)	CARB E.O.	Foot Notes
1988-95 (5.7)	1GD212-SCI	210/300	60-65%	3"	H	stk 6 rib	ProFlow	ProPump, FMU	not req'd	not required	12, 36 opt. (\$99)	D-365-3	DD1, DD2, DD3, DD4, DD5
1988-95 (5.7)	1GD202-SCI	210/300	specify	3"	H	stk 6 rib	ProFlow	not supplied	not req'd	not required	12	-	DD1, DD2, DD3, DD4
1988-95 (5.7)	1GD212-09I	210/300	60-65%	3"	H	stk 6 rib	ProFlow	ProPump, FMU	not req'd	not required	36	D-365-3	DD1, DD2, DD3, DD4, DD5
1988-95 (7.4)	1GE212-SCI	230/385	60-65%	3"	H	stk 6 rib	ProFlow	ProPump, FMU	not req'd	not required	12, 36 opt. (\$99)	D-365-3	DD1, DD2, DD3, DD4
1988-95 (7.4)	1GE202-SCI	230/385	specify	3"	H	stk 6 rib	ProFlow	not supplied	not req'd	not required	12	-	DD1, DD2, DD3, DD4
1988-95 (7.4)	1GE212-09I	230/385	60-65%	3"	H	stk 6 rib	ProFlow	ProPump, FMU	not req'd	not required	36	-	DD1, DD2, DD3, DD4

### CHEVY TRUCK/SUV FOOTNOTES (specific to above applications):

- DD1) Model year must be specified
- DD2) Specify 2WD or 4WD, Truck or SUV
- DD3) Specify engine size
- DD4) Special order kit: order form and non-refundable deposit required at time of order—may require additional lead time for processing
- DD5) 88-95 with smog pump must use P600B



## 2020-23 FORD F-250/350 SUPER DUTY (7.3) SYSTEMS AND KITS

Year	Part Number	Description	Boost Options	HP Gain	Intercooler	Price/MAP
2020-22	1FZ211-SCI	High Output Intercooled System with P-1SC-1	7-8 psi	45%+	3 core	\$8,999
2020-23	1FZ201-SCI	High Output Intercooled Tuner Kit with P-1SC-1	specify	specify	3 core	\$7,699

## \*NEW\* 2021-23 FORD F-150 (5.0 4V) SYSTEMS AND KITS

Year	Part Number	Description	Boost Options	HP Gain	Intercooler	Price/MAP
2021-22	1EA411-SCI	High Output Intercooled System with P-1SC-1	6 psi	50-55%+	3 core	\$8,299
2021-23	1EA401-SCI	High Output Intercooled Tuner Kit with P-1SC-1	specify	specify	3 core	\$7,799
2021-22	1EA511-SCI	Stage II Intercooled System with P-1SC-1	8 psi	60-65%+	Race	\$8,699
2021-23	1EA501-SCI	Stage II Intercooled Tuner Kit with P-1SC-1	specify	specify	Race	\$8,199

## 2018-20 FORD F-150 (5.0 4V) SYSTEMS AND KITS

Year	Part Number	Description	Boost Options	HP Gain	Intercooler	Price/MAP
2018-20	1FY411-SCI	High Output Intercooled System with P-1SC-1	6 psi	50-55%+	3 core	\$7,999
2018-20	1FY401-SCI	High Output Intercooled Tuner Kit with P-1SC-1	specify	specify	3 core	\$7,499
2018-20	1FY511-SCI	Stage II Intercooled System with P-1SC-1	8 psi	60-65%+	Race	\$8,399
2018-20	1FY501-SCI	Stage II Intercooled Tuner Kit with P-1SC-1	specify	specify	Race	\$7,899

## 2015-17 FORD F-150 (5.0 4V) SYSTEMS AND KITS

Year	Part Number	Description	Boost Options	HP Gain	Intercooler	Price/MAP
2015-17	1FY211-SCI	High Output Intercooled System with P-1SC-1	6-7 psi	45-55%	3 core	\$7,849
2015-17	1FY201-SCI	High Output Intercooled Tuner Kit with P-1SC-1	specify	specify	3 core	\$7,449
2015-17	1FY311-SCI	Stage II Intercooled System with P-1SC-1	8-9 psi	60-70%	Race	\$8,399
2015-17	1FY301-SCI	Stage II Intercooled Tuner Kit with P-1SC-1	specify	specify	Race	\$7,799

<b>2020-23 SUPER DUTY (7.3) / 2015-23 F-150 (5.0 4V) OPTIONS</b>	add "-B" or "-P" to part #	Black or Polished finish for ProCharger (P-series or D-series)	satin standard	-	-	+\$325
	add "-B" or "-P" to part #	Black or Polished finish for ProCharger (F-series, 9" housing)	satin standard	-	-	+\$350
	add "-BB" or "-PB" to part #	Black or Polished finish for supercharger bracket	satin standard	-	-	+\$275
	add "-H" to part #	Helical gearset for noise reduction (P-1SC-1, P-1X, D-1SC, D-1X)	same	same	-	+\$110
<b>2015-23 F-150 (5.0 4V) OPTIONS ONLY</b>	add "-P1X" to part #	With P-1X ProCharger (replacing P-1SC-1, Systems and Tuner Kits)	same	add'l 10-15+ hp	-	+\$250
	add "-D1SC" to part #	With D-1SC ProCharger (replacing P-1SC-1)	tuner kit only	specify	-	+\$275
	add "-D1X" to part #	With D-1X ProCharger (replacing P-1SC-1, Tuner Kits only)	tuner kit only	specify	-	+\$475
	add "-D" or "-1" or "-A"	With F-1D, F-1, F-1A ProCharger (replacing P-1SC-1)	tuner kit only	specify	-	+\$875
<b>2015-23 F-150 (5.0 4V) OPTIONS ONLY</b>	add "-D" or "-1" or "-A"	With F-1D, F-1, F-1A ProCharger (replacing D-1SC)	tuner kit only	specify	-	+\$599
	add "-94" to part #	With F-1A-94 ProCharger (replacing P-1SC-1)	tuner kit only	specify	-	+\$1,225
	add "-RVR" or "RVB"	Race Bypass Valve Upgrade (specify open or closed valve) - F150 Tuner Kit only	red or black	specify	-	+\$295
	add "-CS" to part #	Coyote Crank Support (5.0 only)	satin standard	-	-	+\$675
	add "-BC" or "-PC" to part #	Black or Polished finish for Crank Support (5.0 only)	satin standard	-	-	+\$275
	add "-Race" to part #	Air-to-Air Race intercooler upgrade (from 3 core)	from 3 core	1100 hp max	3" tubing	+\$435
	add "-FA" to part #	Forward facing air inlet (rear facing is standard, 2011-14 5.0 only)	same	same	-	+\$130

**FOR COYOTE & GODZILLA ENGINE SWAP KITS, SEE PAGE 24**



# SPECIFICATIONS (2015-2022)

## 2020-23 FORD F-250/350 SUPER DUTY (7.3) SPECIFICATIONS

Year	Part Number	OEM hp/TQ Rating	HP Gain	Tube Diam	IC Mount	Drive System	Bypass System	Fuel System Upgrade	Fuel Inj. Supplied	Computer/Ignition Modifications	SC Warranty (in months)	CARB E.O.	Foot Notes
2020-22	1FZ211-SCI	430/475	45%+	3"	V	stk 6 rib	Bullet	not required	50 lb/hr	programmer supplied	12, 36 opt. (\$99)	-	ED: 1,3,4,6,7,9
2020-23	1FZ201-SCI	430/475	specify	3"	V	stk 6 rib	Bullet	not required	No	not supplied	12	-	ED: 1,6,7,9

## \*NEW\* 2021-23 FORD F-150 (5.0 4V) SPECIFICATIONS

Year	Part Number	OEM hp/TQ Rating	HP Gain	Tube Diam	IC Mount	Drive System	Bypass System	Fuel System Upgrade	Fuel Inj. Supplied	Computer/Ignition Modifications	SC Warranty (in months)	CARB E.O.	Foot Notes
2021-22	1EA411-SCI	395/400	50-55%+	3"	V	add'l 8 rib	ProFlow	not required	not required	programmer supplied	12, 36 opt. (\$99)	-	ED: 1,2,3,4,5,6,7,10
2021-23	1EA401-SCI	395/400	specify	3"	V	add'l 8 rib	ProFlow	not required	No	not supplied	12	-	ED: 1,2,4,6,7,10
2021-22	1EA511-SCI	395/400	60-65%+	3.5"	V	add'l 8 rib	ProFlow	not required	not required	programmer supplied	12, 36 opt. (\$99)	-	ED: 1,2,3,4,5,6,7,10
2021-23	1EA501-SCI	395/400	specify	3.5"	V	add'l 8 rib	ProFlow	not required	No	not supplied	12	-	ED: 1,2,4,6,7,10

## 2018-20 FORD F-150 (5.0 4V) SPECIFICATIONS

Year	Part Number	OEM hp/TQ Rating	HP Gain	Tube Diam	IC Mount	Drive System	Bypass System	Fuel System Upgrade	Fuel Inj. Supplied	Computer/Ignition Modifications	SC Warranty (in months)	CARB E.O.	Foot Notes
2018-20	1FY411-SCI	395/400	50-55%+	3"	V	add'l 8 rib	ProFlow	not required	not required	programmer supplied	12, 36 opt. (\$99)	-	ED: 1,2,3,4,5,6,7
2018-20	1FY401-SCI	395/400	specify	3"	V	add'l 8 rib	ProFlow	not required	No	not supplied	12	-	ED: 1,2,4,6,7
2018-20	1FY511-SCI	395/400	60-65%+	3"	V	add'l 8 rib	ProFlow	not required	not required	programmer supplied	12, 36 opt. (\$99)	-	ED: 1,2,3,4,5,6,7
2018-20	1FY501-SCI	395/400	specify	3"	V	add'l 8 rib	ProFlow	not required	No	not supplied	12	-	ED: 1,2,4,6,7

## 2015-17 FORD F-150 (5.0 4V) SPECIFICATIONS

Year	Part Number	OEM hp/TQ Rating	HP Gain	Tube Diam	IC Mount	Drive System	Bypass System	Fuel System Upgrade	Fuel Inj. Supplied	Computer/Ignition Modifications	SC Warranty (in months)	CARB E.O.	Foot Notes
2015-17	1FY211-SCI	385/387	45-55%	3"	V	add'l 8 rib	ProFlow	not required	not required	programmer supplied	12, 36 opt. (\$99)	D-365-32	ED: 1,2,4,5,6,7
2015-17	1FY201-SCI	385/387	specify	3"	V	add'l 8 rib	ProFlow	not required	No	not supplied	12	-	ED: 1,2,4,6,7
2015-17	1FY311-SCI	385/387	60-70%	3"	V	add'l 8 rib	ProFlow	not required	52 lb/hr	programmer supplied	12, 36 opt. (\$99)	D-365-32	ED: 1,2,4,5,6,7
2015-17	1FY301-SCI	385/387	specify	3"	V	add'l 8 rib	ProFlow	not required	No	not supplied	12	-	ED: 1,2,4,6,7

## FORD TRUCK/SUV FOOTNOTES (specific to above applications):

- ED1) Model year must be specified
- ED2) Specify 2WD or 4WD
- ED3) Due to variability among OEM computers, the prevalence of custom modifications, and age/miles/condition of vehicles, dyno tuning may be required
- ED4) For Flex Fuel vehicles, gasoline-only tune provided, not E85
- ED5) ECM code required on hand-held programmer applications
- ED6) System ships in extra large box
- ED7) 2015+ models require aerodynamic grill shutter removal and/or trimming
- ED8) Two-part shipment, additional shipping charges may apply
- ED9) Works with dual battery; dual alternator requires removing one alternator
- ED10) Special order kit: order form and non-refundable deposit required at time of order—may require additional lead time for processing



**2011-14 FORD F-150 (5.0, 6.2 4V) SYSTEMS AND KITS**

Year	Part Number	Description	Boost Options	HP Gain	Intercooler	Price/MAP
2011-14 (5.0)	1FV211-SCI-5.0	High Output Intercooled System with P-1SC-1	6-7 psi	45-55%	3 core	\$7,299
2011-14 (5.0)	1FV201-SCI-5.0	High Output Intercooled Tuner Kit with P-1SC-1	specify	specify	3 core	\$6,899
2011-14 (5.0)	1FV311-SCI-5.0	Stage II Intercooled System with P-1SC-1	8-9 psi	60-70%	Race	\$7,849
2011-14 (5.0)	1FV301-SCI-5.0	Stage II Intercooled Tuner Kit with P-1SC-1	specify	specify	Race	\$7,199
2011-14 (6.2)	1FS311-SCI-6.2	High Output Intercooled System with D-1SC (6.2)	7-8 psi	50%+	3 core	\$7,999
2011-14 (6.2)	1FS301-SCI-6.2	High Output Intercooled Tuner Kit with D-1SC (6.2)	specify	specify	3 core	\$7,049
2011-14 (6.2)	1FS211-SCI-6.2	Stage II Intercooled System with P-1SC-1 (6.2)	7-8 psi	50%+	3 core	\$8,349
2011-14 (6.2)	1FS201-SCI-6.2	Stage II Intercooled Tuner Kit with P-1SC-1 (6.2)	specify	specify	3 core	\$7,399

<b>2011-14 F-150 (5.0, 6.2 4V) OPTIONS</b>	add "-B" or "-P" to part #	Black or Polished finish for ProCharger (P-series or D-series)	satin standard	-	-	+\$325
	add "-B" or "-P" to part #	Black or Polished finish for ProCharger (F-series, 9" housing)	satin standard	-	-	+\$350
	add "-BB" or "-PB" to part #	Black or Polished finish for supercharger bracket	satin standard	-	-	+\$275
	add "-H" to part #	Helical gearset for noise reduction (P-1SC-1, P-1X, D-1SC, D-1X)	same	same	-	+\$110
	add "-P1X" to part #	With P-1X ProCharger (replacing P-1SC-1, Systems and Tuner Kits)	same	add'l 10-15+ hp	-	+\$250
	add "-D1SC" to part #	With D-1SC ProCharger (replacing P-1SC-1)	tuner kit only	specify	-	+\$275
	add "-D1X" to part #	With D-1X ProCharger (replacing P-1SC-1, Tuner Kits only)	tuner kit only	specify	-	+\$475
	add "-D" or "-1" or "-A"	With F-1D, F-1, F-1A ProCharger (replacing P-1SC-1)	tuner kit only	specify	-	+\$875
	add "-D" or "-1" or "-A"	With F-1D, F-1, F-1A ProCharger (replacing D-1SC)	tuner kit only	specify	-	+\$599
	add "-94" to part #	With F-1A-94 ProCharger (replacing P-1SC-1)	tuner kit only	specify	-	+\$1,225
	add "-RVR" or "RVB"	Race Bypass Valve Upgrade (specify open or closed valve) - F150 Tuner Kit only	red or black	specify	-	+\$295
	add "-CS" to part #	Coyote Crank Support (5.0 only)	satin standard	-	-	+\$675

add "-BC" or "-PC" to part #

Black or Polished finish for Crank Support (5.0 only)

satin standard

-

-

-

+\$275

add "-Race" to part #

Air-to-Air Race intercooler upgrade (from 3 core)

from 3 core

1100 hp max

3" tubing

+\$435

add "-FA" to part #

Forward facing air inlet (rear facing is standard, 2011-14 5.0 only)

same

same

-

+\$130

**2011-14 FORD F-150 (5.0, 6.2 4V) i-1 PROGRAMMABLE RATIO SYSTEMS**

Year	Part Number	Description	Boost Options	HP Gain	Intercooler	Price/MAP
2011-14 (5.0)	1FV215-SCI	High Output Intercooled System with i-1 (5.0)	8-9 psi	60-70%	Race	\$10,399
2011-14 (6.2)	1FS215-SCI	High Output Intercooled System with i-1 (6.2)	8 psi	55%+	3 core	\$10,499

<b>i-1 OPTIONS</b>	add "-T" to part #	Touchscreen (at time of system purchase)	-	-	-	+\$395
	add "-B" to part #	Black finish (supercharger and bracket)	satin standard	-	-	+\$795
	add "-P" to part #	Polished finish (supercharger and bracket)	satin standard	-	-	+\$595
	add "-Race" to part #	Air-to-air race intercooler upgrade	from 3 core	1050 max hp	-	+\$435

**FOR COYOTE & GODZILLA ENGINE SWAP KITS, SEE PAGE 24**

# SPECIFICATIONS (2011-2014)

## 2011-14 FORD F-150 (5.0, 6.2 4V) SPECIFICATIONS

Year	Part Number	OEM hp/TQ Rating	HP Gain	Tube Diam	IC Mount	Drive System	Bypass System	Fuel System Upgrade	Fuel Inj. Supplied	Computer/Ignition Modifications	SC Warranty (in months)	CARB E.O.	Foot Notes
2011-14 (5.0)	1FV211-SCI	360/380	45-55%	3"	V	add'l 8 rib	ProFlow	not required	not required	programmer supplied	12, 36 opt. (\$99)	D-365-32	EE: 1,2,4,5,6
2011-14 (5.0)	1FV201-SCI	360/380	specify	3"	V	add'l 8 rib	ProFlow	not required	No	not supplied	12	-	EE: 1,2,4,6
2011-14 (5.0)	1FV311-SCI	360/380	60-70%	3"	V	add'l 8 rib	ProFlow	not required	52 lb/hr	programmer supplied	12, 36 opt. (\$99)	D-365-32	EE: 1,2,4,5,6
2011-14 (5.0)	1FV301-SCI	360/380	specify	3"	V	add'l 8 rib	ProFlow	not required	No	not supplied	12	-	EE: 1,2,4,6
2011-14 (6.2)	1FS311-SCI-6.2	411/434	50%+	3"	V	stk 6 rib	ProFlow	not required	63 lb/hr	programmer supplied	12, 36 opt. (\$99)	-	EE: 1,2,3,4,5,6
2011-14 (6.2)	1FS301-SCI-6.2	411/434	specify	3"	V	stk 6 rib	ProFlow	not required	No	not supplied	12	-	EE: 1,2,6
2011-14 (6.2)	1FS211-SCI-6.2	411/434	50%+	3"	V	add'l 8 rib	ProFlow	not required	63 lb/hr	programmer supplied	12, 36 opt. (\$99)	D-365-32	EE: 1,2,4,5,6
2011-14 (6.2)	1FS201-SCI-6.2	411/434	specify	3"	V	add'l 8 rib	ProFlow	not required	No	not supplied	12	-	EE: 1,2,6

## 2011-14 FORD F-150 (5.0, 6.2 4V) i-1 PROGRAMMABLE RATIO SPECIFICATIONS

Year	Part Number	OEM hp/TQ Rating	HP Gain	Tube Diam	IC Mount	Drive System	Bypass System	Fuel System Upgrade	Fuel Inj. Supplied	Computer/Ignition Modifications	SC Warranty (in months)	CARB E.O.	Foot Notes
2011-14 (5.0)	1FV215-SCI	360/380	60-70%	3"	V	add'l 8 rib	ProFlow	not required	52 lb/hr	programmer supplied	12, 36 opt. (\$149)	-	EE: 1,2,3,4,5,6,7,8
2011-14 (6.2)	1FS215-SCI	411/434	55%+	3"	V	add'l 8 rib	ProFlow	not required	63 lb/hr	programmer supplied	12, 36 opt. (\$149)	-	EE: 1,2,3,4,5,6,7,8

### FORD TRUCK/SUV FOOTNOTES (specific to above applications):

- EE1) Model year must be specified
- EE2) Specify 2WD or 4WD
- EE3) Due to variability among OEM computers, the prevalence of custom modifications, and age/miles/condition of vehicles, dyno tuning may be required
- EE4) For Flex Fuel vehicles, gasoline-only tune provided, not E85
- EE5) ECM code required on hand-held programmer applications
- EE6) System ships in extra large box
- EE7) Two-part shipment, additional shipping charges may apply
- EE8) Special order kit: order form and non-refundable deposit required at time of order; may require additional lead time for processing



**2010-14 FORD F-150 SVT RAPTOR (5.4, 6.2 3V) SYSTEMS AND KITS**

Year	Part Number	Description	Boost Options	HP Gain	Intercooler	Price
2010-14 (6.2)	1FS311-SCI-6.2	High Output Intercooled System with D-1SC	7-8 psi	50%+	3 core	\$7,999
2010-14 (6.2)	1FS301-SCI-6.2	High Output Intercooled Tuner Kit with D-1SC	specify	specify	3 core	\$7,049
2010-14 (6.2)	1FS211-SCI-6.2	Stage II Intercooled System with P-1SC-1 (dedicated 8-rib drive)	7-8 psi	50%+	3 core	\$8,349
2010-14 (6.2)	1FS201-SCI-6.2	Stage II Intercooled Tuner Kit with P-1SC-1 (dedicated 8-rib drive)	specify	specify	3 core	\$7,399
2010 (5.4)	1FS211-SCI-5.4	High Output Intercooled System with P-1SC-1	8-9 psi	60%+	3 core	\$8,299
2010 (5.4)	1FS201-SCI-5.4	High Output Intercooled Tuner Kit with P-1SC-1	specify	specify	3 core	\$7,299

<b>2010-14 RAPTOR (6.2, 5.4) OPTIONS</b>	add "-B" or "-P" to part #	Black or Polished finish for ProCharger (P-series or D-series )	satin standard	-	-	+\$325
	add "-BB" or "-PB" to part #	Black or Polished finish for supercharger bracket	satin standard	-	-	+\$275
	add "-H" to part #	Helical gerset for noise reduction (P-1SC-1, P-1X, D-1SC, D-1X)	same	same	-	+\$110
	add "-P1X" to part #	With P-1X ProCharger (replacing P-1SC-1, Systems and Tuner Kits)	same	add'l 10-15+ hp	-	+\$250
	add "-D1SC" to part #	With D-1SC ProCharger (replacing P-1SC-1)	tuner kit only	specify	-	+\$275
	add "-D1X" to part #	With D-1X ProCharger (replacing P-1SC-1, Tuner Kits only)	tuner kit only	specify	-	+\$475
	add "-Race" to part #	Air-to-air race intercooler upgrade	from 3 core	1050 hp max	-	+\$435

**2010-14 FORD F-150 SVT RAPTOR (6.2) i-1 PROGRAMMABLE RATIO SYSTEMS**

Year	Part Number	Description	Boost Options	HP Gain	Intercooler	Price/MAP
2010-14 (6.2)	1FS215-SCI	High Output Intercooled System with i-1	8 psi	55%+	3 core	\$10,499

<b>i-1 OPTIONS</b>	add "-T" to part #	Touchscreen (at time of system purchase)	-	-	-	+\$395
	add "-B" to part #	Black finish (supercharger and bracket)	satin standard	-	-	+\$795
	add "-P" to part #	Polished finish (supercharger and bracket)	satin standard	-	-	+\$595
	add "-Race" to part #	Air-to-air race intercooler upgrade	from 3 core	1050 hp max	-	+\$435

**2004-10 FORD F-150 AND 2007-10 EXPEDITION (5.4 3V) SYSTEMS AND KITS**

Year	Part Number	Description	Boost Options	HP Gain	Intercooler	Price/MAP
2009-10	1FN211-SCI	High Output Intercooled System with P-1SC-1 (F-150)	8-9 psi	60-65%	2 core	\$7,399
2009-10	1FN201-SCI	High Output Intercooled Tuner Kit with P-1SC-1 (F-150)	specify	specify	2 core	\$6,699
2004-08	1FN211-SCI	High Output Intercooled System with P-1SC-1 (F-150)	8-9 psi	60-65%	2 core	\$7,299
2004-08	1FN201-SCI	High Output Intercooled Tuner Kit with P-1SC-1 (F-150)	specify	specify	2 core	\$6,599
2007-08	1FN211-SCI	High Output Intercooled System with P-1SC-1 (Expedition)	8-9 psi	60-65%	2 core	\$7,399
2007-10	1FN201-SCI	High Output Intercooled Tuner Kit with P-1SC-1 (Expedition)	specify	specify	2 core	\$6,699

**1997-03 FORD F-150 AND 1997-02 EXPEDITION (5.4, 4.6 2V) SYSTEMS AND KITS**

Year	Part Number	Description	Boost Options	HP Gain	Intercooler	Price/MAP
1997-03 (5.4)	1FG211-SCI	High Output Intercooled System with P-1SC (F150/Expedition*)	8-9 psi	60-65%	2 or 3 core, see below	\$6,799
1997-03 (5.4)	1FG201-SCI	High Output Intercooled Tuner Kit with P-1SC (F150/Expedition*)	specify	specify	2 or 3 core, see below	\$6,499
1997-03 (4.6)	1FH211-SCI	High Output Intercooled System with P-1SC (F150/Expedition*)	8-9 psi	60-65%	2 or 3 core, see below	\$6,799
1997-03 (4.6)	1FH201-SCI	High Output Intercooled Tuner Kit with P-1SC (F150/Expedition*)	specify	specify	2 or 3 core, see below	\$6,499

<b>1997-2010 F-150 &amp; EXPEDITION</b>	add "-B" or "-P" to part #	Black or Polished finish for ProCharger (P-series or D-series)	satin standard	-	-	+\$325
	add "-H" to part #	Helical gerset for noise reduction (P-1SC, D-1SC)	same	same	-	+\$110
	add "-D1SC" to part #	With D-1SC ProCharger (replacing P-1SC)	specify	specify	-	+\$495
	add "-D1SC" to part #	With D-1SC ProCharger (replacing P-1SC-1)	tuner kit only	specify	-	+\$275
	add "-3C" to part #	3 core intercooler system upgrade (2004+ only)	from 2 core	825 hp max	3" tubing	+\$435

\* Excludes 2003 Expedition

**FOR COYOTE & GODZILLA ENGINE SWAP KITS, SEE PAGE 24**



# SPECIFICATIONS (1997-2010 F-150 & 2010-14 RAPTOR)

## 2010-14 FORD F-150 SVT RAPTOR (6.2, 5.4 3V) SPECIFICATIONS

Year	Part Number	OEM hp/TQ Rating	HP Gain	Tube Diam	IC Mount	Drive System	Bypass System	Fuel System Upgrade	Fuel Inj. Supplied	Computer/Ignition Modifications	SC Warranty (in months)	CARB E.O.	Foot Notes
2010-14 (6.2)	1FS311-SCI-6.2	411/434	50%+	3"	V	stk 6 rib	ProFlow	not required	63 lb/hr	programmer sup.	12, 36 opt. (\$99)	-	FF1, FF2, FF3, FF5, FF6, FF8
2010-14 (6.2)	1FS301-SCI-6.2	411/434	specify	3"	V	stk 6 rib	ProFlow	not required	No	not supplied	12	-	FF1, FF2, FF6, FF8
2010-14 (6.2)	1FS211-SCI-6.2	411/434	50%+	3"	V	add'l 8 rib	ProFlow	not required	63 lb/hr	programmer sup.	12, 36 opt. (\$99)	D-365-8	FF1, FF6, FF8
2010-14 (6.2)	1FS201-SCI-6.2	411/434	specify	3"	V	add'l 8 rib	ProFlow	not required	No	not supplied	12	-	FF1, FF6, FF8
2010 (5.4)	1FS211-SCI-5.4	320/390	60%	3"	V	stk 6 rib	ProFlow	not required	39.5 lb/hr	programmer sup.	12, 36 opt. (\$99)	D-365-8	FF1, FF2, FF3, FF6, FF8
2010 (5.4)	1FS201-SCI-5.4	320/390	specify	3"	V	stk 6 rib	ProFlow	not required	No	not supplied	12	-	FF1, FF2, FF6, FF8

## 2010-14 FORD F-150 SVT RAPTOR (6.2) i-1 PROGRAMMABLE RATIO SPECIFICATIONS

Year	Part Number	OEM hp/TQ Rating	HP Gain	Tube Diam	IC Mount	Drive System	Bypass System	Fuel System Upgrade	Fuel Inj. Supplied	Computer/Ignition Modifications	SC Warranty (in months)	CARB E.O.	Foot Notes
2010-14 (6.2)	1FS215-SCI	411/434	55%+	3"	V	add'l 8 rib	ProFlow	not required	63 lb/hr	programmer sup.	12, 36 opt. (\$149)	-	FF1, FF5, FF6, FF8, FF9, FF10

## 2004-10 FORD F-150 & 2007-10 EXPEDITION (5.4 3V) SPECIFICATIONS

Year	Part Number	OEM hp/TQ Rating	HP Gain	Tube Diam	IC Mount	Drive System	Bypass System	Fuel System Upgrade	Fuel Inj. Supplied	Computer/Ignition Modifications	SC Warranty (in months)	CARB E.O.	Foot Notes
2009-10 (5.4)	1FN211-SCI	310/365	60-65%	3"	V	stk 6 rib	ProFlow	not required	not req.	programmer sup.	12, 36 opt. (\$99)	D-365-8	FF1, FF2, FF6, FF7, FF8
2009-10 (5.4)	1FN201-SCI	310/365	specify	3"	V	stk 6 rib	ProFlow	not required	No	not supplied	12	-	FF1, FF2, FF8
2004-08 (5.4)	1FN211-SCI	300/365	60-65%	3"	V	stk 6 rib	ProFlow	not required	39.5 lb/hr	programmer sup.	12, 36 opt. (\$99)	D-365-8	FF1, FF2, FF7, FF8
2004-08 (5.4)	1FN201-SCI	300/365	specify	3"	V	stk 6 rib	ProFlow	not required	No	not supplied	12	-	FF1, FF2, FF8
2007-08 (5.4)	1FN211-SCI	300/365	60-65%	3"	V	stk 6 rib	ProFlow	not required	39.5 lb/hr	programmer sup.	12, 36 opt. (\$99)	D-365-8	FF1, FF2, FF7, FF8
2007-10 (5.4)	1FN201-SCI	300/365	specify	3"	V	stk 6 rib	ProFlow	not required	No	not supplied	12	-	FF1, FF2, FF8

## 1997-03 FORD F-150 & 1997-02 EXPEDITION (5.4, 4.6 2V) SPECIFICATIONS

Year	Part Number	OEM hp/TQ Rating	HP Gain	Tube Diam	IC Mount	Drive System	Bypass System	Fuel System Upgrade	Fuel Inj. Supplied	Computer/Ignition Modifications	SC Warranty (in months)	CARB E.O.	Foot Notes
1997-03 (5.4)	1FG211-SCI	260/345	60-65%	3"	V	add'l 6 rib	ProFlow	ProPump, FMU	not req.	not required	12, 36 opt. (\$99)	D-365-2/8	FF1, FF2, FF3, FF4, FF9
1997-03 (5.4)	1FG201-SCI	260/345	specify	3"	V	add'l 6 rib	ProFlow	not supplied	not req.	not required	12	-	FF1, FF2, FF3, FF4, FF9
1997-03 (4.6)	1FH211-SCI	210/290	60-65%	3"	V	add'l 6 rib	ProFlow	ProPump, FMU	not req.	not required	12, 36 opt. (\$99)	D-365-8 (02-03)	FF1, FF2, FF3, FF4, FF9
1997-03 (4.6)	1FH201-SCI	210/290	specify	3"	V	add'l 6 rib	ProFlow	not supplied	not req.	not required	12	-	FF1, FF2, FF3, FF4, FF9

### FORD TRUCK/SUV FOOTNOTES (specific to above applications):

- FF1) Model year must be specified
- FF2) Specify 2WD or 4WD, Truck or SUV
- FF3) Fits Light Duty F-250 applications with minor modifications
- FF4) 1997-98 Ford F-150/Expedition systems/kits include 2 core intercooler, 1999-03 include 3 core intercooler
- FF5) Due to variability among OEM computers, the prevalence of custom modifications, and age/miles/condition of vehicles, dyno tuning may be required
- FF6) For Flex Fuel vehicles, gasoline-only tune provided, not E85
- FF7) ECM code required on hand-held programmer applications
- FF8) System ships in extra large box
- FF9) Special order kit: order form and non-refundable deposit required at time of order—may require additional lead time for processing
- FF10) Two-part shipment, additional shipping charges may apply



**2011-22 RAM 1500 CLASSIC / 2019-22 RAM 1500 (5.7) / eTORQUE (5.7) SYSTEMS AND KITS (SPECIFY IF REBEL OR GT)**

Year	Part Number	Description	Boost Options	HP Gain	Intercooler	Price/MAP
2019-22	1DP314-SCI	High Output Intercooled System with D-1SC	7 psi	140+ hp	3 core	\$8,199
2019-22	1DP304-SCI	High Output Intercooled Tuner Kit with D-1SC	specify	specify	3 core	\$7,449
2019-22	1DP315-SCI	Stage II Intercooled System with P-1SC-1 (dedicated 8-rib drive)	7 psi	140+ hp	3 core	\$8,799
2019-22	1DP305-SCI	Stage II Intercooled Tuner Kit with P-1SC-1 (dedicated 8-rib drive)	specify	specify	3 core	\$8,049
2019-22	1DP415-SCI	Stage II Intercooled System with P-1SC-1 (eTorque)	7 psi	140+ hp	3 core	\$8,799
2019-22	1DP405-SCI	Stage II Intercooled Tuner Kit with P-1SC-1 (eTorque)	specify	specify	3 core	\$8,049
2011-22	1DH314-SCI	High Output Intercooled System with D-1SC (CLASSIC)	7 psi	140+ hp	3 core	\$8,199
2011-22	1DH304-SCI	High Output Intercooled Tuner Kit with D-1SC (CLASSIC)	specify	specify	3 core	\$7,449
2011-22	1DH315-SCI	Stage II Intercooled System with P-1SC-1 (dedicated 8-rib drive) (CLASSIC)	7 psi	140+ hp	3 core	\$8,799
2011-22	1DH305-SCI	Stage II Intercooled Tuner Kit with P-1SC-1 (dedicated 8-rib drive) (CLASSIC)	specify	specify	3 core	\$8,049

<b>2011-22 RAM (5.7) OPTIONS</b>	add "B" or "P" to part #	Black or Polished finish for ProCharger (P-series or D-series)	satin standard	-	-	+\$325
	add "B" or "P" to part #	Black or Polished finish for ProCharger (F-series 9"-9.75" housing)	satin standard	-	-	+\$350
	add "BB" or "PB" to part #	Black or Polished finish for supercharger bracket	satin standard	-	-	+\$275
	add "H" to part #	Helical gerset for noise reduction (P-1SC-1, P-1X, D-1SC, D-1X)	same	same	-	+\$110
<b>5.7 HO ONLY</b>	add "D1X" to part #	With D-1X ProCharger (replacing D-1SC)	tuner kit only	specify	-	+\$200
<b>5.7 STAGE II ONLY</b>	add "P1X" to part #	With P-1X ProCharger (replacing P-1SC-1, Systems and Tuner Kits)	same	add'l 10-15+ hp	-	+\$250
	add "D1SC" to part #	With D-1SC ProCharger (replacing P-1SC-1)	tuner kit only	specify	-	+\$275
	add "D1X" to part #	With D-1X ProCharger (replacing P-1SC-1)	tuner kit only	specify	-	+\$475
	add "D" or "1" or "A"	With F-1D, F-1, F-1A ProCharger (replacing P-1SC-1)	tuner kit only	specify	-	+\$875
	add "94" or "C" or "R" to part #	With F-1A-94, F-1C, F-1R ProCharger (replacing P-1SC-1)	tuner kit only	specify	-	+\$1,225
	add "RVR" or "RVB"	Race Bypass Valve Upgrade (specify open or closed valve)	red or black	specify	-	+\$295
	add "ATIPP" to part #	ATI Performance Products Balancer Upgrade (non-eTorque)	-	-	-	+\$525

**2014-22 RAM 2500/3500 AND POWER WAGON (6.4) SYSTEMS & KITS**

Year	Part Number	Description	Boost Options	HP Gain	Intercooler	Price/MAP
2019-21	1DN312-SCI	High Output Intercooled Systems with D-1SC	6 psi	130+ hp	3 core	\$8,599
2019-22	1DN302-SCI	High Output Intercooled Tuner Kit with D-1SC	specify	specify	3 core	\$7,599
2014-18	1DN212-SCI	High Output Intercooled Systems with D-1SC	6 psi	130+ hp	3 core	\$8,499
2014-18	1DN202-SCI	High Output Intercooled Tuner Kit with D-1SC	specify	specify	3 core	\$7,499

<b>2014-22 RAM (6.4) OPTIONS</b>	add "B" or "P" to part #	Black or Polished finish for ProCharger (P-series)	satin standard	-	-	+\$325
	add "BB" or "PB" to part #	Black or Polished finish for supercharger bracket	satin standard	-	-	+\$275
	add "H" to part #	Helical gerset for noise reduction (D-1SC)	same	same	-	+\$110
	add "PW" to part #	Power Wagon w/ Factory Winch (2014-18 only, 19+ included)	same	same	-	+\$175

**2018-21 DODGE DURANGO SRT (6.4) SYSTEMS & KITS**

Year	Part Number	Description	Boost Options	HP Gain	Intercooler	Price/MAP
2018-21	1DL215-SCI	High Output Intercooled System with P-1SC-1	7 psi	215+ hp	3 core	\$8,699
2018-21	1DL205-SCI	High Output Intercooled Tuner Kit with P-1SC-1	specify	specify	3 core	\$7,649

<b>2018-21 DODGE DURANGO SRT (6.4) OPTIONS</b>	add "B" or "P" to part #	Black or Polished finish for ProCharger (P-series or D-series )	satin standard	-	-	+\$325
	add "B" or "P" to part #	Black or Polished finish for ProCharger (F-series, 9" housing)	satin standard	-	-	+\$350
	add "BB" or "PB" to part #	Black or Polished finish for supercharger bracket	satin standard	-	-	+\$275
	add "H" to part #	Helical gerset for noise reduction (P-1SC-1, P-1X, D-1SC, D-1X)	same	same	-	+\$110
	add "P1X" to part #	With P-1X ProCharger (replacing P-1SC-1, System and Tuner Kit)	same	add'l 10-15+ hp	-	+\$250
	add "D1SC" to part #	With D-1SC ProCharger (replacing P-1SC-1)	tuner kit only	specify	-	+\$275
	add "D1X" to part #	With D-1X ProCharger (replacing P-1SC-1, Tuner Kit only)	tuner kit only	specify	-	+\$475
	add "D" or "1" or "A"	With F-1, F-1A, F-1D ProCharger (replacing P-1SC-1)	tuner kit only	specify	-	+\$875
	add "RVR" or "RVB"	Race Bypass Valve Upgrade (specify open or closed valve)	red or black	specify	-	+\$295

**CALL FOR INFO ON 2022-2023 RAM GT****COMING SOON: 2018-21 DODGE DURANGO (5.7) SYSTEMS & KITS**

# SPECIFICATIONS (2018-21 DURANGO & 2011-22 RAM)

## 2011-22 RAM 1500 CLASSIC / 2019-22 RAM 1500 (5.7) / eTORQUE (5.7) SPECIFICATIONS (SPECIFY IF REBEL OR GT)

Year	Part Number	OEM hp/TQ Rating	HP Gain	Tube Diam	IC Mount	Drive System	Bypass System	Fuel System Upgrade	Fuel Inj. Supplied	Computer/Ignition Modifications	Supercharger Warranty (in months)	CARB E.O.	Foot Notes
2019-22	1DP314-SCI	390/407	140+ hp	3"	V	stk 6 rib	ProFlow	not required	39.5 lb/hr	programmer sup.	12, 36 opt. (\$99)	-	GG1, GG2, GG3, GG4, GG5, GG6
2019-22	1DP304-SCI	390/407	specify	3"	V	stk 6 rib	ProFlow	-	No	not supplied	12	-	GG1, GG2, GG4, GG5
2019-22	1DP315-SCI	390/407	140+ hp	3"	V	add'l 8 rib	ProFlow	not required	39.5 lb/hr	programmer sup.	12, 36 opt. (\$99)	-	GG1, GG2, GG3, GG4, GG5, GG6, GG7
2019-22	1DP305-SCI	390/407	specify	3"	V	add'l 8 rib	ProFlow	-	No	not supplied	12	-	GG1, GG2, GG4, GG5, GG7
2019-22	1DP415-SCI	390/407	140+ hp	3"	V	add'l 8 rib	ProFlow	not required	39.5 lb/hr	programmer sup.	12, 36 opt. (\$99)	-	GG1, GG2, GG3, GG4, GG5, GG6
2019-22	1DP405-SCI	390/407	specify	3"	V	add'l 8 rib	ProFlow	-	No	not supplied	12	-	GG1, GG2, GG4, GG5
2011-22	1DH314-SCI	390/407	140+ hp	3"	V	stk 6 rib	ProFlow	not required	39.5 lb/hr	programmer sup.	12, 36 opt. (\$99)	-	GG1, GG2, GG3, GG4, GG5, GG6
2011-22	1DH304-SCI	390/407	specify	3"	V	stk 6 rib	ProFlow	-	No	not supplied	12	-	GG1, GG2, GG4, GG5
2011-22	1DH315-SCI	390/407	140+ hp	3"	V	add'l 8 rib	ProFlow	not required	39.5 lb/hr	programmer sup.	12, 36 opt. (\$99)	D-365-9 (09-14) D-365-18 (15-18)	GG1, GG2, GG4, GG5, GG6, GG7
2011-22	1DH305-SCI	390/407	specify	3"	V	add'l 8 rib	ProFlow	-	No	not supplied	12	-	GG1, GG2, GG4, GG5, GG7

## 2014-22 RAM 2500/3500 AND POWER WAGON (6.4) SPECIFICATIONS

Year	Part Number	OEM hp/TQ Rating	HP Gain	Tube Diam	IC Mount	Drive System	Bypass System	Fuel System Upgrade	Fuel Inj. Supplied	Computer/Ignition Modifications	SC Warranty (in months)	CARB E.O.	Foot Notes
2019-21	1DN312-SCI	410/429	130+ hp	3"	V	stk 6 rib	ProFlow	not required	52 lb/hr	programmer sup.	12, 36 opt. (\$99)	-	GG1, GG2, GG3, GG6
2019-21	1DN302-SCI	410/429	specify	3"	V	stk 6 rib	ProFlow	-	No	not supplied	12	-	GG1, GG2
2014-18	1DN212-SCI	410/429	130+ hp	3"	V	stk 6 rib	ProFlow	not required	52 lb/hr	programmer sup.	12, 36 opt. (\$99)	-	GG1, GG2, GG3, GG6
2014-18	1DN202-SCI	410/429	specify	3"	V	stk 6 rib	ProFlow	-	No	not supplied	12	-	GG1, GG2

## 2018-21 DODGE DURANGO SRT (6.4) SPECIFICATIONS

Year	Part Number	OEM hp/TQ Rating	HP Gain	Tube Diam	IC Mount	Drive System	Bypass System	Fuel System Upgrade	Fuel Inj. Supplied	Comp./Ignition Modifications	SC Warranty (in months)	CARB E.O.	Foot Notes
2018-21	1DL215-SCI	475/470	215+ hp	3"	V	stk 6 rib	ProFlow	MAP sensor	52 lb/hr	programmer sup.	12, 36 opt. (\$99)	D-365-26	GG1, GG6
2018-21	1DL205-SCI	475/470	specify	3"	V	stk 6 rib	ProFlow	not supplied	No	not supplied	12	-	GG1

### DODGE TRUCK/SUV FOOTNOTES (specific to above applications):

- GG1) Model year must be specified
- GG2) Specify 2WD or 4WD
- GG3) Due to variability among OEM computers, the prevalence of custom modifications, and age/miles/condition of vehicles, dyno tuning may be required
- GG4) Systems are for 1500 Series only; modification and custom tuning required for 2011-13 2500 Series vehicles and above (2500, 3500, Mega Cab, and Power Wagon) (Tuner Kits only)
- GG5) 2013+ models require aerodynamic-shutter removal
- GG6) 2015+ vehicles require ECM unlock (call for details)
- GG7) Requires ATI Performance Products balancer #918453 (not included - specify hardened hub)



CONTACT US AT (913) 338-2886 OR LEARN MORE AT PROCHARGER.COM

**2009-10 RAM (5.7) SYSTEMS AND KITS**

Year	Part Number	Description	Boost Options	HP Gain	Intercooler	Price/MAP
2009-10	1DH214-SCI	High Output Intercooled System with P-1SC-1	7 psi	130+ hp	3 core	\$7,849
2009-10	1DH204-SCI	High Output Intercooled Tuner Kit with P-1SC-1	specify	specify	3 core	\$6,999
2009-10	1DH315-SCI	Stage II Intercooled System with P-1SC-1 (dedicated 8-rib drive)	7 psi	130+ hp	3 core	\$8,799
2009-10	1DH305-SCI	Stage II Intercooled Tuner Kit with P-1SC-1 (dedicated 8-rib drive)	specify	specify	3 core	\$8,049

**2004-08 DODGE RAM (5.7) SYSTEMS AND KITS**

Year	Part Number	Description	Boost Options	HP Gain	Intercooler	Price/MAP
2004-08	1DC214-SCI	High Output Intercooled System with P-1SC-1	6 psi	45-50%	3 core high mount	\$7,799
2004-08	1DC204-SCI	High Output Intercooled Tuner Kit with P-1SC-1	tuner kit only	specify	3 core high mount	\$6,899

<b>2004-10 RAM (5.7) OPTIONS</b>	add "-B" or "-P" to part #	Black or Polished finish for ProCharger (P-series or D-series)	satin standard	-	-	+\$325
	add "-PB" to part #	Polished finish for supercharger bracket	satin standard	-	-	+\$300
	add "-H" to part #	Helical gearset for noise reduction (P-1SC-1, D-1SC)	same	same	-	+\$110
	add "-D1SC" to part #	With D-1SC ProCharger (replacing P-1SC-1)	tuner kit only	specify	-	+\$275
	add "-LM" to part #	Low mount intercooler (replacing 3 core high mount, 2006-08 only)	same	same	same	+\$110
	add "-ATIPP" to part #	ATI Performance Products Balancer Upgrade (2009-10 Stage II only)	-	-	-	+\$525

**1996-01 DODGE RAM (5.2, 5.9) TUNER KIT**

Year	Part Number	Description	Boost Options	Est. hp Gain	Intercooler	Price/MAP
1996-01	1DA202-SCI	High Output Intercooled Tuner Kit with P-1SC	8-9 psi	55-60%	2 core	\$6,699

**1997-01 DODGE DAKOTA/DURANGO (5.2, 5.9) TUNER KIT**

Year	Part Number	Description	Boost Options	Est. hp Gain	Intercooler	Price/MAP
1997-01	1DB202-SCI	High Output Intercooled Tuner Kit with P-1SC	8-9 psi	55-60%	2 core	\$6,699

<b>1996-01 RAM, DAKOTA, DURANGO</b>	add "-B" or "-P" to part #	Black or Polished finish for ProCharger (P-series or D-series)	satin standard	-	-	+\$325
	add "-H" to part #	Helical gearset for noise reduction (P-1SC, D-1SC)	same	same	-	+\$110
	add "-D1SC" to part #	With D-1SC ProCharger (replacing P-1SC)	tuner kit only	specify	-	+\$495
	add "-3C" to part #	3 core intercooler system upgrade (Ram only)	from 2 core	825 hp max	3" tubing	+\$435



## SPECIFICATIONS (1997-2001 DURANGO & 1996-2010 RAM)

### 2009-10 RAM (5.7) SPECIFICATIONS

Year	Part Number	OEM hp/TQ Rating	HP Gain	Tube Diam	IC Mount	Drive System	Bypass System	Fuel System Upgrade	Fuel Inj. Supplied	Computer/Ignition Modifications	Supercharger Warranty (in months)	CARB E.O.	Foot Notes
2009-10	1DH214-SCI	390/407	130+ hp	3"	V	stk 6 rib	ProFlow	not required	39.5 lb/hr	programmer sup.	12, 36 opt. (\$99)	D-365-9	HH1, HH2, HH6
2009-10	1DH204-SCI	390/407	specify	3"	V	stk 6 rib	ProFlow	-	No	not supplied	12	-	HH1, HH2, HH6
2009-10	1DH315-SCI	390/407	130+ hp	3"	V	add'l 8 rib	ProFlow	not required	39.5 lb/hr	programmer sup.	12, 36 opt. (\$99)	D-365-9	HH1, HH2, HH6
2009-10	1DH305-SCI	390/407	specify	3"	V	add'l 8 rib	ProFlow	-	No	not supplied	12	-	HH1, HH2, HH6

### 2004-08 DODGE RAM (5.7) SPECIFICATIONS

Year	Part Number	OEM hp/TQ Rating	HP Gain	Tube Diam	IC Mount	Drive System	Bypass System	Fuel System Upgrade	Fuel Inj. Supplied	Computer/Ignition Modifications	Supercharger Warranty (in months)	CARB E.O.	Foot Notes
2004-08	1DC214-SCI	345/375	45-50%	3"	V	stk 7 rib	ProFlow	not required	39.5 lb/hr	programmer sup.	12, 36 opt. (\$99)	D-365-7	HH1, HH2, HH4, HH6, HH7
2004-08	1DC204-SCI	345/375	specify	3"	V	stk 7 rib	ProFlow	not supplied	No	not supplied	12	-	HH1, HH2, HH4, HH6, HH7

### 1996-01 DODGE RAM (5.9, 5.2) SPECIFICATIONS

Year	Part Number	OEM hp/TQ Rating	Est. hp Gain	Tube Diam	IC Mount	Drive System	Bypass System	Fuel System Upgrade	Fuel Inj. Supplied	Computer/Ignition Modifications	Supercharger Warranty (in months)	CARB E.O.	Foot Notes
1996-01	1DA202-SCI	250/335	55-60%	3"	H	stk 7 rib	ProFlow	not supplied	not required	not required	12	-	HH1, HH2, HH5, HH6, HH7

### 1997-01 DODGE DAKOTA/DURANGO (5.9, 5.2) SPECIFICATIONS

Year	Part Number	OEM hp/TQ Rating	Est. hp Gain	Tube Diam	IC Mount	Drive System	Bypass System	Fuel System Upgrade	Fuel Inj. Supplied	Computer/Ignition Modifications	Supercharger Warranty (in months)	CARB E.O.	Foot Notes
1997-01	1DB202-SCI	250/335	55-60%	3"	H	stk 7 rib	ProFlow	not supplied	not required	not required	12	-	HH1, HH2, HH5, HH6, HH7

### DODGE TRUCK/SUV FOOTNOTES (specific to above applications):

- HH1) Model year must be specified
- HH2) Specify 2WD or 4WD
- HH4) Low mount intercooler option available for 2006-08 model years only
- HH5) MSD boost timing master may be required (sold separately by others)
- HH6) For 1500 Series only; modification and custom tuning required for 2500 Series vehicles and above (2500, 3500, Mega Cab, and Power Wagon) (Tuner Kits only)
- HH7) Special order kit: order form and non-refundable deposit required at time of order—may require additional lead time for processing



**2012-20 JEEP GRAND CHEROKEE (6.4) SYSTEMS & KITS**

Year	Part Number	Description	Boost Options	HP Gain	Intercooler	Price/MAP
2012-20	1DL214-SCI	High Output Intercooled System with P-1SC-1	7 psi	215+	3 core	\$8,799
2012-20	1DL204-SCI	High Output Intercooled Tuner Kit with P-1SC-1	specify	specify	3 core	\$7,749

**2011-20 JEEP GRAND CHEROKEE (5.7) SYSTEMS AND KITS**

Year	Part Number	Description	Boost Options	HP Gain	Intercooler	Price/MAP
2011-20	1DM214-SCI	High Output Intercooled System with P-1SC-1	7 psi	160+	3 core	\$8,299
2011-20	1DM204-SCI	High Output Intercooled Tuner Kit with P-1SC-1	specify	specify	3 core	\$7,199

**2006-10 JEEP GRAND CHEROKEE SRT8 (6.1) SYSTEMS AND KITS**

Year	Part Number	Description	Boost Options	HP Gain	Intercooler	Price/MAP
2006-10	1DJ214-SCI	High Output Intercooled System with P-1SC-1	7 psi	160+	3 core	\$8,199
2006-10	1DJ204-SCI	High Output Intercooled Tuner Kit with P-1SC-1	specify	specify	3 core	\$6,899
2006-10	1DJ314-SCI	Stage II Intercooled System with P-1SC-1 (dedicated 8-rib)	7 psi	160+	3 core	\$8,699
2006-10	1DJ304-SCI	Stage II Intercooled Tuner Kit with P-1SC-1 (dedicated 8-rib)	specify	specify	3 core	\$7,349

<b>2006-20 GRAND CHEROKEE (6.4, 5.7, 6.1) OPTIONS</b>	add "-B" or "-P" to part #	Black or Polished finish for ProCharger (P-series or D-series)	satin standard	-	-	+\$325
	add "-B" or "-P" to part #	Black or Polished finish for ProCharger (F-series, 9" housing)	satin standard	-	-	+\$350
	add "-BB" or "-PB" to part #	Black or Polished finish for supercharger bracket	satin standard	-	-	+\$275
	add "-H" to part #	Helical gears for noise reduction (P-1SC-1, P-1X, D-1SC, D-1X)	same	same	-	+\$110
	add "-P1X" to part #	With P-1X ProCharger (replacing P-1SC-1, System and Tuner Kit)	same	add'l 10-15+ hp	-	+\$250
	add "-D1SC" to part #	With D-1SC ProCharger (replacing P-1SC-1)	tuner kit only	specify	-	+\$275
	add "-D1X" to part #	With D-1X ProCharger (replacing P-1SC-1, Tuner Kit only)	tuner kit only	specify	-	+\$475
	add "-D" or "-1" or "-A"	With F-1, F-1A, F-1D ProCharger (replacing P-1SC-1)	tuner kit only	specify	-	+\$875
	add "-94" to part #	With F-1A-94 ProCharger (replacing P-1SC-1)	tuner kit only	specify	-	+\$1,225
add "-RVR" or "RVB"	Race Bypass Valve Upgrade (specify open or closed valve, Tuner Kits only)	red or black	specify	-	+\$295	
add "-Race" to part #	Air-to-Air Race intercooler upgrade	from 3 core	1100 hp max	-	+\$435	

**2020-22 JEEP GLADIATOR JT (3.6) SYSTEMS AND KITS**

Year	Part Number	Description	Boost Options	HP Gain	Intercooler	Price/MAP
2020-21	1JT214-SCI	High Output Intercooled System with P-1SC-1	7 psi	40-45%+	custom JL	\$7,399
2020-22	1JT204-SCI	High Output Intercooled Tuner Kit with P-1SC-1	specify	specify	custom JL	\$6,549

**2018-22 JEEP WRANGLER JL (3.6) SYSTEMS AND KITS (NON-ETORQUE)**

Year	Part Number	Description	Boost Options	HP Gain	Intercooler	Price/MAP
2018-21	1JL214-SCI	High Output Intercooled System with P-1SC-1	7 psi	40-45%+	custom JL	\$7,399
2018-22	1JL204-SCI	High Output Intercooled Tuner Kit with P-1SC-1	specify	specify	custom JL	\$6,549

**2012-18 JEEP WRANGLER JK (3.6) SYSTEMS AND KITS**

Year	Part Number	Description	Boost Options	HP Gain	Intercooler	Price/MAP
2012-18	1JK214-SCI	High Output Intercooled System with P-1SC-1	7 psi	50%+	custom JK	\$7,399
2012-18	1JK204-SCI	High Output Intercooled Tuner Kit with P-1SC-1	specify	specify	custom JK	\$6,549

<b>2012-22 WRANGLER JL / JK (3.6) OPTIONS</b>	add "-B" or "-P" to part #	Black or Polished finish for ProCharger (P-series or D-series)	satin standard	-	-	+\$325
	add "-BB" or "-PB" to part #	Black or Polished finish for supercharger bracket	satin standard	-	-	+\$325
	add "-BI" to part #	Black finish for Intercooler	satin standard	-	-	+\$175
	add "-H" to part #	Helical gears for noise reduction (P-1SC-1, D-1SC)	same	same	-	+\$110
	add "-D1SC" to part #	With D-1SC ProCharger (replacing P-1SC-1)	tuner kit only	specify	-	+\$275

**CALL FOR MORE INFO ON: 2021-22 GRAND CHEROKEE & 2021-22 GRAND WAGONEER**

# SPECIFICATIONS (WRANGLER / GLADIATOR / GRAND CHEROKEE)

## 2012-20 JEEP GRAND CHEROKEE (6.4) SPECIFICATIONS

Year	Part Number	OEM hp/TQ Rating	HP Gain	Tube Diam	IC Mount	Drive System	Bypass System	Fuel System Upgrade	Fuel Inj. Supplied	Comp./Ignition Modifications	SC Warranty (in months)	CARB E.O.	Foot Notes
2012-20	1DL214-SCI	475/470	215+ hp	3"	V	stk 6 rib	ProFlow	MAP sensor	52 lb/hr	programmer sup.	12, 36 opt. (\$99)	D-365-26 (12-20)	111, 116, 118
2012-20	1DL204-SCI	475/470	specify	3"	V	stk 6 rib	ProFlow	not supplied	No	not supplied	12	-	111, 118

## 2011-20 JEEP GRAND CHEROKEE (5.7) SPECIFICATIONS

Year	Part Number	OEM hp/TQ Rating	HP Gain	Tube Diam	IC Mount	Drive System	Bypass System	Fuel System Upgrade	Fuel Inj. Supplied	Comp./Ignition Modifications	SC Warranty (in months)	CARB E.O.	Foot Notes
2011-20	1DM214-SCI	360/390	160+ hp	3"	V	stk 6 rib	ProFlow	MAP sensor	39.5 lb/hr	programmer sup.	12, 36 opt. (\$99)	D-365-22 (11-19)	111, 116, 118
2011-20	1DM204-SCI	360/390	specify	3"	V	stk 6 rib	ProFlow	not supplied	No	not supplied	12	-	111, 118

## 2006-10 JEEP GRAND CHEROKEE SRT8 (6.1) SPECIFICATIONS

Year	Part Number	OEM hp/TQ Rating	HP Gain	Tube Diam	IC Mount	Drive System	Bypass System	Fuel System Upgrade	Fuel Inj. Supplied	Comp./Ignition Modifications	SC Warranty (in months)	CARB E.O.	Foot Notes
2006-10	1DJ214-SCI	425/425	160+ hp	3"	V	stk 6 rib	ProFlow	MAP sensor, pump voltage booster	52 lb/hr	programmer sup.	12, 36 opt. (\$99)	D-365-9	111
2006-10	1DJ204-SCI	425/425	specify	3"	V	stk 6 rib	ProFlow	not supplied	No	not supplied	12	-	111
2006-10	1DJ314-SCI	425/425	160+ hp	3"	V	add'l 8 rib	ProFlow	MAP sensor, pump voltage booster	52 lb/hr	programmer sup.	12, 36 opt. (\$99)	D-365-9	111, 117
2006-10	1DJ304-SCI	425/425	specify	3"	V	add'l 8 rib	ProFlow	not supplied	No	not supplied	12	-	111, 117

## 2020-22 JEEP GLADIATOR JT (3.6) SPECIFICATIONS

Year	Part Number	OEM hp/TQ Rating	HP Gain	Tube Diam	IC Mount	Drive System	Bypass System	Fuel System Upgrade	Fuel Inj. Supplied	Comp./Ignition Modifications	SC Warranty (in months)	CARB E.O.	Foot Notes
2020-21	1JT214-SCI	285/260	40-45%+	2.5-3"	V	stk 6 rib	ProFlow	not required	50 lb/hr	programmer sup.	12, 36 opt. (\$99)	D-365-19 (20 only)	111, 112, 113, 115, 116, 119
2020-22	1JT204-SCI	285/260	specify	2.5-3"	V	stk 6 rib	ProFlow	not supplied	No	not supplied	12	-	111, 112, 113, 115

## 2018-22 JEEP WRANGLER JL (3.6) SPECIFICATIONS (NON-ETORQUE)

Year	Part Number	OEM hp/TQ Rating	HP Gain	Tube Diam	IC Mount	Drive System	Bypass System	Fuel System Upgrade	Fuel Inj. Supplied	Comp./Ignition Modifications	SC Warranty (in months)	CARB E.O.	Foot Notes
2018-21	1JL214-SCI	285/260	40-45%+	2.5-3"	V	stk 6 rib	ProFlow	not required	50 lb/hr	programmer sup.	12, 36 opt. (\$99)	D-365-19 (18-20)	111, 112, 113, 115, 116, 119
2018-22	1JL204-SCI	285/260	specify	2.5-3"	V	stk 6 rib	ProFlow	not supplied	No	not supplied	12	-	111, 112, 113, 115

## 2012-18 JEEP WRANGLER JK (3.6) SPECIFICATIONS

Year	Part Number	OEM hp/TQ Rating	HP Gain	Tube Diam	IC Mount	Drive System	Bypass System	Fuel System Upgrade	Fuel Inj. Supplied	Comp./Ignition Modifications	SC Warranty (in months)	CARB E.O.	Foot Notes
2012-18	1JK214-SCI	285/260	50%+	2.5-3"	V	stk 6 rib	ProFlow	not required	50 lb/hr	programmer sup.	12, 36 opt. (\$99)	D-365-19	111, 112, 113, 115, 116
2012-18	1JK204-SCI	285/260	specify	2.5-3"	V	stk 6 rib	ProFlow	not supplied	No	not supplied	12	-	111, 112, 113, 115

## JEEP WRANGLER, GLADIATOR, & GRAND CHEROKEE FOOTNOTES (specific to above applications):

- 111) Model year must be specified
- 112) Specify 2WD or 4WD
- 113) Specify manual or automatic transmission
- 115) May not work with some aftermarket parts or accessories
- 116) 2015+ vehicles may require ECM unlock (call for details)
- 117) Requires ATI Performance Products balancer #918432 (not included - specify hardened hub)
- 118) Some trimming required to airbox tabs
- 119) Fits PCM GPEC2A only; call regarding GPEC5



**2010-19 TOYOTA 4RUNNER (4.0) SYSTEMS & KITS**

Year	Part Number	Description	Boost Options	HP Gain	Intercooler	Price/MAP
2010-19	1TK212-SCI	High Output Intercooled System with D-1SC	7-8 psi	40-45%	3 core	\$7,399
2010-19	1TK202-SCI	High Output Intercooled Tuner Kit with D-1SC	specify	specify	3 core	\$6,449

<b>2010-19 4RUNNER (4.0) OPTIONS</b>	add "-B" or "-P" to part #	Black or Polished finish for ProCharger	satin standard	-	-	+\$325
	add "-BB" or "-PB" to part #	Black or Polished finish for supercharger bracket	satin standard	-	-	+\$275
	add "-MC"	Optional ProCharger intake manifold cover (satin)	unfinished std	-	-	+\$145
	add "-BC"	Black finish for optional intake manifold cover	unfinished std	-	-	+\$35
	add "-H" to part #	Helical gearsset for noise reduction	same	same	-	+\$110
	add "-IU" to part #	Air-to-Air intercooler option for aftermarket bumper and/or winch	from standard	-	-	n/c

**2016-23 TOYOTA TACOMA (3.5) SYSTEMS & KITS**

Year	Part Number	Description	Boost Options	HP Gain	Intercooler	Price/MAP
2016-23	1TM212SCI	High Output Intercooled System with D-1SC	7-8 psi	40-45%	3 core	\$7,399
2016-23	1TM202SCI	High Output Intercooled Tuner Kit with D-1SC	specify	specify	3 core	\$6,449

**2005-15 TOYOTA TACOMA (4.0) SYSTEMS & KITS**

Year	Part Number	Description	Boost Options	HP Gain	Intercooler	Price/MAP
2005-15	1TL212-SCI	High Output Intercooled System with D-1SC	7-8 psi	40-45%	3 core	\$6,799
2005-15	1TL202-SCI	High Output Intercooled Tuner Kit with D-1SC	specify	specify	3 core	\$5,849

<b>2005-23 TACOMA (3.5,4.0) OPTIONS</b>	add "-B" or "-P" to part #	Black or Polished finish for ProCharger	satin standard	-	-	+\$325
	add "-BB" or "-PB" to part #	Black or Polished finish for supercharger bracket	satin standard	-	-	+\$275
	add "-H" to part #	Helical gearsset for noise reduction	same	same	-	+\$110
	add "-IU" to part #	Air-to-Air intercooler upgrade for aftermarket bumper and/or winch (05-15 only)	from standard	-	-	n/c
	add "-BI" to part #	Black finish for intercooler	satin standard	-	-	+\$175

**2007-20 TOYOTA TUNDRA (5.7) SYSTEMS & KITS - COMING SOON**

Year	Part Number	Description	Boost Options	HP Gain	Intercooler	Price/MAP
2007-20	TBD	High Output Intercooled System with P-1SC-1	TBD	TBD	TBD	TBD
2007-20	TBD	High Output Intercooled Tuner Kit with P-1SC-1	TBD	TBD	TBD	TBD



# SPECIFICATIONS (4RUNNER, TACOMA, TUNDRA)

## 2010-19 TOYOTA 4RUNNER (4.0) SPECIFICATIONS

Year	Part Number	OEM hp/TQ Rating	HP Gain	Tube Diam	IC Mount	Drive System	Bypass System	Fuel System Upgrade	Fuel Inj. Supplied	Comp./Ignition Modifications	SC Warranty (in months)	CARB E.O.	Foot Notes
2010-19	1TK212-SCI	270/278	40-45%+	3"	V	add'l 6 rib	ProFlow	-	60 lb/hr	programmer sup.	12, 36 opt. (\$99)	D-365-30 (2010-19)	TT: 1, 2, 3, 5, 7, 8
2010-19	1TK202-SCI	270/278	specify	3"	V	add'l 6 rib	ProFlow	not supplied	No	not supplied	12	-	TT: 1, 2, 3, 5, 7, 8

## 2016-23 TOYOTA TACOMA (3.5) SPECIFICATIONS

Year	Part Number	OEM hp/TQ Rating	HP Gain	Tube Diam	IC Mount	Drive System	Bypass System	Fuel System Upgrade	Fuel Inj. Supplied	Comp./Ignition Modifications	SC Warranty (in months)	CARB E.O.	Foot Notes
2016-23	1TM212-SCI	278/265	40-45%	3"	V	stk 6 rib	ProFlow	-	-	programmer sup.	12, 36 opt. (\$99)	D-365-30	TT: 1, 2, 3, 5, 6, 7, 8, 9
2016-23	1TM202-SCI	278/265	specify	3"	V	stk 6 rib	ProFlow	not supplied	No	not supplied	12	-	TT: 1, 2, 3, 5, 6, 7, 8, 9

## 2005-15 TOYOTA TACOMA (4.0) SPECIFICATIONS

Year	Part Number	OEM hp/TQ Rating	HP Gain	Tube Diam	IC Mount	Drive System	Bypass System	Fuel System Upgrade	Fuel Inj. Supplied	Comp./Ignition Modifications	SC Warranty (in months)	CARB E.O.	Foot Notes
2005-15	1TL212-SCI	236/266	40-45%	3"	V	add'l 6 rib	ProFlow	pump voltage booster	52 lb/hr	programmer sup.	12, 36 opt. (\$99)	D-365-30 (2005-13)	TT: 1, 2, 3, 5, 6, 7
2005-15	1TL202-SCI	236/266	specify	3"	V	add'l 6 rib	ProFlow	not supplied	No	not supplied	12	-	TT: 1, 2, 3, 5, 6, 7

## 2007-20 TOYOTA TUNDRA (5.7) SPECIFICATIONS - COMING SOON

### TOYOTA 4RUNNER, TACOMA, TUNDRA FOOTNOTES (specific to above applications):

- TT1) Model year must be specified
- TT2) Specify 2WD or 4WD or AWD
- TT3) Specify manual or automatic transmission
- TT5) May not work with some aftermarket parts or accessories
- TT6) Radiator support modification required
- TT7) Specify with or without winch/snorkel option
- TT8) Battery relocation required (single battery bracket supplied)
- TT9) Specify passenger or driver side ABS



CONTACT US AT (913) 338-2886 OR LEARN MORE AT PROCHARGER.COM

**2015-19 POLARIS SLINGSHOT**

Year	Part Number	Description	Boost Options	HP Gain	Intercooler	Price/MAP
2015-19	1PD112-SCI	High Output Intercooled System with CS-1	8 psi	55%+	3 core	\$5,999
2015-19	1PD102-SCI	High Output Intercooled Tuner Kit with CS-1	specify	specify	3 core	\$5,799
<b>OPTIONS</b>	add "-B" or "-P" to part #	Black or Polished finish for ProCharger	satin standard	-	-	+\$325
	add "-BB" or "-PB" to part #	Black or Polished finish for supercharger bracket	satin standard	-	-	+\$275

**2003-06 NISSAN 350Z (3.5) TUNER KITS (DOES NOT FIT 2006 REV-UP ENGINE MODEL)**

Year	Part Number	Description	Boost Options	Est. hp Gain	Intercooler	Price/MAP
2003-06	1NB202-SCI	High Output Intercooled Tuner Kit with C-2	7 psi	55-60%	350Z	\$6,699
<b>OPTIONS</b>	add "-P" to part #	Polished finish for ProCharger (7" housing)	head unit only	-	-	+\$250

**2003-04 INFINITI G35 COUPE AND FX35 (3.5) TUNER KITS**

Year	Part Number	Description	Boost Options	Est. hp Gain	Intercooler	Price/MAP
2003-04	1NC202-SCI	High Output Intercooled Tuner Kit with C-2	6 psi	45-50%	G35	\$6,699
<b>OPTIONS</b>	add "-P" to part #	Polished finish for ProCharger (7" housing)	head unit only	-	-	+\$250

**1999-00 HONDA CIVIC Si (1.6 DOHC) TUNER KITS**

Year	Part Number	Description	Boost Options	Est. hp Gain	Intercooler	Price/MAP
1999-00	1HA202-SCI	High Output Intercooled Tuner Kit with C-1A	9 psi	70-75%	2 core	\$5,999
<b>OPTIONS</b>	add "-P" to part #	Polished finish for ProCharger (7" housing)	head unit only	-	-	+\$250
	add "-3C" to part #	3 core intercooler system upgrade	from 2 core	-	-	+\$435

**1994-01 ACURA INTEGRA GSR AND TYPE R (1.8 DOHC) TUNER KITS**

Year	Part Number	Description	Boost Options	Est. hp Gain	Intercooler	Price/MAP
1994-01	1HB202-SCI	High Output Intercooled Tuner Kit with C-1A	8 psi	70-75%	2 core	\$5,999
<b>OPTIONS</b>	add "-P" to part #	Polished finish for ProCharger (7" housing)	head unit only	-	-	+\$250
	add "-3C" to part #	3 core intercooler system upgrade	from 2 core	-	-	+\$435

**2000-04 FORD FOCUS (ZETEC, SVT) TUNER KITS**

Year	Part Number	Description	Boost Options	Est. hp Gain	Intercooler	Price/MAP
2000-03	1FK202-SCI	High Output Intercooled Tuner Kit with C-1B (Zetec)	8, 10 psi	65-80%	Focus	\$5,599
2002-04	1FK302-SCI	High Output Intercooled Tuner Kit with C-1B (SVT)	8, 10 psi	65-80%	Focus	\$5,599
<b>OPTIONS</b>	add "-P" to part #	Polished finish for ProCharger (7" housing)	head unit only	-	-	+\$250

**LOOKING FOR V-TWIN OR POWERSPORTS SUPERCHARGER SYSTEMS? GIVE US A CALL!**

# SPECIFICATIONS (SPORT COMPACT / SLINGSHOT)

## 2015-19 POLARIS SLINGSHOT SPECIFICATIONS

Year	Part Number	OEM hp Rating	HP Gain	Tube Diam	Intercooler Mount	Drive System	Bypass System	Fuel System Upgrade	Fuel Inj. Supplied	Computer/Ignition Modifications	Supercharger Warranty (in months)	CARB E.O.	Foot Notes
2015-19	1PD112-SCI	173	55%+	2.5"	V	stk 6 rib	ProFlow Bullet	not required	not req.	tuning certificate	12	-	JJ6
2015-19	1PD102-SCI	173	specify	2.5"	V	stk 6 rib	ProFlow Bullet	not required	No	No	12	-	JJ6

## 2003-06 NISSAN 350Z (3.5) SPECIFICATIONS

Year	Part Number	OEM hp Rating	Est. hp Gain	Tube Diam	Intercooler Mount	Drive System	Bypass System	Fuel System Upgrade	Fuel Inj. Supplied	Computer/Ignition Modifications	Supercharger Warranty (in months)	CARB E.O.	Foot Notes
2003-06	1NB202-SCI	287	55-60%	2.5"	V	stk 6 rib	ProFlow	not supplied	No	not supplied	12	-	JJ1, JJ3, JJ5, JJ6

## 2003-04 INFINITI G35 COUPE, FX35 (3.5) SPECIFICATIONS

Year	Part Number	OEM hp Rating	Est. hp Gain	Tube Diam	Intercooler Mount	Drive System	Bypass System	Fuel System Upgrade	Fuel Inj. Supplied	Computer/Ignition Modifications	Supercharger Warranty (in months)	CARB E.O.	Foot Notes
2003-04	1NC202-SCI	280	45-50%	2.5"	V	stk 6 rib	ProFlow	not supplied	No	not supplied	12	-	JJ1, JJ5, JJ6

## 1999-00 HONDA CIVIC Si (1.6L DOHC) SPECIFICATIONS

Year	Part Number	OEM hp Rating	Est. hp Gain	Tube Diam	Intercooler Mount	Drive System	Bypass System	Fuel System Upgrade	Fuel Inj. Supplied	Computer/Ignition Modifications	Supercharger Warranty (in months)	CARB E.O.	Foot Notes
1999-00	1HA202-SCI	160	70-75%	2.5"	V	stk 4 rib	Bosch	not supplied	No	not supplied	12	-	JJ1, JJ5, JJ6

## 1994-01 ACURA INTEGRA GSR, TYPE R (1.8L DOHC) SPECIFICATIONS

Year	Part Number	OEM hp Rating	Est. hp Gain	Tube Diam	Intercooler Mount	Drive System	Bypass System	Fuel System Upgrade	Fuel Inj. Supplied	Computer/Ignition Modifications	Supercharger Warranty (in months)	CARB E.O.	Foot Notes
1994-01	1HB202-SCI	170	70-75%	2.5"	V	stk 4 rib	Bosch	not supplied	No	not supplied	12	-	JJ1, JJ2, JJ4, JJ5, JJ6

## 2000-04 FORD FOCUS (ZETEC, SVT) SPECIFICATIONS

Year	Part Number	OEM hp Rating	Est. hp Gain	Tube Diam	Intercooler Mount	Drive System	Bypass System	Fuel System Upgrade	Fuel Inj. Supplied	Computer/Ignition Modifications	Supercharger Warranty (in months)	CARB E.O.	Foot Notes
2000-03	1FK202-SCI	130	65-80%	2.5"	H	stk 6 rib	Bosch	not required	No	not supplied	12	-	JJ1, JJ5, JJ6
2002-04	1FK302-SCI	170	65-80%	2.5"	H	stk 6 rib	Bosch	not required	No	not supplied	12	-	JJ1, JJ5, JJ6

## SPORT COMPACT FOOTNOTES (specific to above applications):

- JJ1) Model year must be specified
- JJ2) Specify GS-R or Type R
- JJ3) For Non Rev-up engines only
- JJ4) Acura Integra systems and kits require modifications to bumper support
- JJ5) Boost levels are for reference only—tuning and fuel system upgrades may be required (sold by others)
- JJ6) Special order kit: order form and non-refundable deposit required at time of order—may require additional lead time for processing



	A-1R	B-1	CS-1	C-1	C-2	P600B	P-1SC	P-1SC-1	P-1X	P-1SC-2	D-1	D-1SC	D-1X	F-1D	F-1	F-1A	F-1A-91	F-1A-94
<b>VOLUTE DIAMETER</b>	7"	7"	7"	7"	7"	9"	9"	9"	9"	9"	9"	9"	9"	9"	9"	9"	9"	9"
<b>MAX SUPERCHARGED HP</b>	150	250	550	675	725	775	825	825	950	825	925	925	1075	1050	1050	1100	1200	1300
<b>MOTOR BASE HP RANGE*</b>	50-95	60-150	150-325	150-325	175-375	200-500	200-500	200-450	300-500	200-450	300-500	300-500	300-550	300-500	300-500	300-500	300-500	300-550
<b>MAX FLOW (CFM)</b>	450	600	900	1000	1000	1150	1200	1200	1275	1200	1400	1400	1500	1500	1525	1575	1600	1625
<b>MAX BOOST (PSI)</b>	15	20	24	24	24	24	30	32	32	30	32	32	32	34	38	38	38	38
<b>INLET HOSE DIAMETER</b>	3"	3"	3.5"	3.5"	3.5"	3.75"	3.75"	3.75"	3.75"	3.75"	3.75"	3.75"	3.75"	3.75"	3.75"	3.75"	3.75"	4"
<b>INDUCER DIAMETER</b>	2.28"	2.28"	2.66"	2.75"	3.14"	3.37"	3.37"	3.37"	3.57"	3.24"	3.37"	3.37"	3.57"	3.37"	3.57"	3.5"	3.57"	3.7"
<b>EXDUCER DIAMETER</b>	3.2"	3.2"	3.7"	4.25"	4.25"	6.25"	6.25"	5.25"	5.56"	6"	6.25"	6.25"	6.20"	6.25"	6"	5.56"	5.56"	5.56"
<b>OUTLET HOSE DIAMETER</b>	2"	2"	2.5"	2.5"	2.5"	3"	3"	3"	3"	3"	3"	3"	3"	3"	3"	3"	3"	3"
<b>OUTLET I.D.</b>	1.75"	1.75"	2.12"	2.12"	2.12"	2.62"	2.62"	2.62"	2.62"	2.62"	2.62"	2.62"	2.62"	2.62"	2.62"	2.62"	2.62"	2.62"
<b>MAX IMPELLER RPM</b>	75,000	110,000	80,000	80,000	80,000	60,000	62,000	65,000	65,000	60,000	65,000	62,000	65,000	65,000	70,000	74,000	74,000	74,000
<b>INTERNAL STEP-UP</b>	4.11:1	4.95:1	8.30:1	4.70:1	4.70:1	3.05:1	4.10:1	4.10:1	4.10:1	4.10:1	4.44:1	4.10:1	4.10:1	5.40:1	5.40:1	5.40:1	5.40:1	5.40:1
<b>REVERSE ROTATION OPTION</b>	Yes	Yes	Yes	Yes	Yes	Yes	Yes	Yes	Yes	Yes	Yes	Yes	Yes	Yes	Yes	Yes	Yes	Yes
<b>SELF CONTAINED</b>	Yes	Yes	Yes	Yes	Yes	No	Yes	Yes	Yes	Yes	No	Yes	Yes	Yes	Yes	Yes	Yes	Yes
<b>OIL CAPACITY</b>	2.5 oz	2.5 oz	3.2 oz	2.5 oz	2.5 oz	-	6 oz	6 oz	6 oz	6 oz	-	6 oz	6 oz	4 oz	4 oz	4 oz	4 oz	4 oz

- The stated figures are not absolutes, and may actually be higher depending upon the specific application.
- Figures based on stated peak airflows; actual power levels may be higher in well prepared engines.
- Please refer to [www.procharger.com](http://www.procharger.com) for additional supercharger specifications.

- Engine intake air temperature is the most relevant thermal measure (not SAE J1723) for a supercharger installed on a vehicle, especially when intercooled; SAE J1723 does not address the impact of engine dynamics, engine compartment heat transfer, intercooling or deficiencies caused by supercharger location.



# RACE SUPERCHARGER SPECIFICATIONS

EFFECTIVE DATE 04/28/23

	F-1C	F-1R	F-1X	F-2	F-3D-102	F-3D-106	F-3R-102	F-3R-112*	F-3R-121	F-3R-130	F-3R-136	F-3R-140	F-4X-136	F-4X-140	F-4X-140-1	F-4X-144	F-4X-145
<b>VOLUTE DIAMETER</b>	9.75"	9.75"	10.5"	10.5"	10.5"	10.5"	12"	12"	12"	12"	12"	12"	13.5"	13.5"	13.5"	13.5"	13.5"
<b>MAX SUPERCHARGED HP</b>	1,100	1,250	1,400	1,450	1,500	1,800	1,600	2,100	2,400	2,700	3,000	3,300	3,200	3,500	3,700	4,000	4,200
<b>MOTOR BASE HP RANGE</b>	300-550	375-550	375-550	425-600	550-750	550-750	375-550	CALL	CALL	CALL	CALL	CALL	CALL	CALL	CALL	CALL	CALL
<b>MAX FLOW (CFM)</b>	1,625	1,700	2,000	2,100	1,900	2,200	2,000	2,300	3,100	3,600	4,000	4,300	4,200	4,500	4,700	5,000	5,200
<b>MAX BOOST (PSI)</b>	38	38	38	38	38	38	38	38	40	45	50	58	55	60	65	70	72
<b>INLET HOSE DIAMETER</b>	4"	4.05"	4.8"	4.6"	4.8"	4.8"	6"	5"	5.5"	5.75"	5.75"	5.75"	6"	6"	6"	6"	6"
<b>INDUCER DIAMETER</b>	3.7"	4"	4.20"	4.5"	4"	4.2"	4"	4.4"	4.8"	5.12"	5.35"	5.47"	5.35"	5.47"	5.51"	5.63"	5.71"
<b>EXDUCER DIAMETER</b>	5.56"	6"	6"	6.75"	6"	6"	6.75"	6.75"	6.75"	7.22"	7.22"	7.22"	7.22"	7.22"	7.42"	7.91"	7.69"
<b>OUTLET HOSE DIAMETER</b>	3"	3"	3.5"	3.5"	3.5"	3.5"	4.5"	4"	4"	4"	4"	4"	4.5"	4.5"	4.5"	4.5"	4.5"
<b>OUTLET I.D.</b>	2.62"	2.62"	3.15"	3.15"	3.15"	3.15"	3.59"	3.59"	3.59"	3.59"	3.59"	3.59"	4"	4"	4"	4"	4"
<b>MAX IMPELLER RPM</b>	74,000	68,000	72,000	65,000	74,000	74,000	72,000	72,000	72,000	72,000	72,000	72,000	72,000	72,000	72,000	72,000	72,000
<b>INTERNAL STEP-UP</b>	5.40:1	5.40:1	5.40:1	5.40:1	5.63:1	5.63:1	5.63:1	5.63:1	5.63:1	5.63:1	5.63:1	5.63:1	4.77:1	4.77:1	4.77:1	4.77:1	4.77:1
<b>REVERSE ROTATION OPTION</b>	Yes	Yes	Yes	Yes	Yes	Yes	Yes	Yes	Yes	Yes	Yes	No	No	No	No	No	No
<b>SELF CONTAINED</b>	Yes	Yes	Yes	Yes	Yes	Yes	Yes	Yes	Yes	Yes	Yes	Yes	Yes	Yes	Yes	Yes	Yes
<b>OIL CAPACITY</b>	4 oz	4 oz	4 oz	4 oz	4 oz	4 oz	4 oz	4 oz	4 oz	4 oz	4 oz	6 oz	6 oz	6 oz	6 oz	6 oz	6 oz

- \*Formally F-1X-12
- F-1/F-2 superchargers are rated based upon high horsepower street engines. F-3 superchargers are rated based upon maximum effort race engines.
- The stated figures are not absolutes, and may actually be higher depending upon the specific application.
- Please refer to [www.procharger.com](http://www.procharger.com) for additional supercharger specifications.

- Figures based on stated peak airflows; actual power levels may be higher in well prepared engines.
- Engine intake air temperature is the most relevant thermal measure (not SAE J1723) for a supercharger installed on a vehicle, especially when intercooled; SAE J1723 does not address the impact of engine dynamics, engine compartment heat transfer, intercooling or deficiencies caused by supercharger location.

## SUPERCHARGERS

Part Number	Description	Price/MAP
PC065A-002	A-1R ProCharger (satin)	\$2,698
PC064A-002	B-1 ProCharger (satin)	\$2,698
PC061A-001	C-1 ProCharger (satin)	\$2,998
PC061A-003	C-1R ProCharger (satin)	\$3,398
PC061A-xxx	C-1R-72 ProCharger (satin)	\$3,598
PC062A-001	C-2 ProCharger (satin)	\$3,398
PC061A-004	CS-1 ProCharger (satin)	\$3,498
PC010A-002	P600B ProCharger (satin)	\$3,098
PC050A-001	P-1SC ProCharger (satin)	\$3,378
PC050A-040	P-1SC-1 ProCharger (satin)	\$3,598
PC053A-040	P-1X ProCharger (satin)	\$3,848
PC041A-001	D-1 ProCharger (satin)	\$3,798
PC051A-001	D-1SC ProCharger (satin)	\$3,873
PC054A-001	D-1X ProCharger (satin)	\$4,073
PC323A-001	F-1D ProCharger (satin)	\$4,473
PC324A-001	F-1 ProCharger (satin)	\$4,473
PC325A-001	F-1A ProCharger (satin)	\$4,473
PC335A-001	F-1A-91 ProCharger (satin)	\$4,823
PC336A-001	F-1A-94 ProCharger (satin)	\$4,823
PC327A-001	F-1C ProCharger (satin)	\$4,823
PC326A-001	F-1R ProCharger (satin)	\$4,823
PC330A-001	F-1X ProCharger (satin)	\$6,088
PC328A-002	F-2 ProCharger (satin)	\$6,288
PC314A-102	F-3D-102 ProCharger (satin)	\$6,998
PC314A-106	F-3D-106 ProCharger (satin)	\$6,998
PC314A-102R	F-3R-102 ProCharger (satin) with splined input shaft and threaded volute	\$8,134
PC314A-112R	F-3R-112 (F-1X-12) ProCharger (satin)	\$7,438
PC314A-121R	F-3R-121 ProCharger (satin)	\$7,738
PC314A-130	F-3R-130 ProCharger (satin)	\$7,998
PC314A-136	F-3R-136 ProCharger (satin)	\$8,398
PC314A-140-C-SP-T	F-3R-140 ProCharger (satin) with splined input shaft and threaded volute	\$10,298
PC318A-136-C-SP-T	F-4X-136 ProCharger (satin) with splined input shaft and threaded volute	\$10,898
PC318A-140-C-SP-T	F-4X-140 ProCharger (satin) with splined input shaft and threaded volute	\$12,998
PC318A-141-C-SP-T	F-4X-140-1 ProCharger (satin) with splined input shaft and threaded volute	\$14,998
PC318A-144-C-SP-T	F-4X-144 ProCharger (satin) with splined input shaft and threaded volute	\$16,998
PC318A-145-C-SP-T	F-4X-145 ProCharger (satin) with splined input shaft and threaded volute	\$17,998
PC314A-12A-RD	F-3R-112RD (F-1X-12RD) ProCharger RaceDrive	\$11,998
PC314A-121-RD	F-3R-121RD ProCharger RaceDrive	\$11,998
CALL	F-3R Threaded Volute w/ V-Band Clamp (New Head Unit builds)	\$249
CALL	F-3R Threaded Volute w/ Dual Seal Flange (New Head Unit builds)	\$249
CALL	F-3D/F-3R Splined Input Shaft Option	\$179
PC016A-001	Polished or Black Finish of (A, B, C, P, D, F-series) 7" or 9" Models (at time of purchase)	\$375
PC016A-002	Polished or Black Finish of (F-1C, F-1R) 9.75" Models (at time of purchase)	\$425
PC016A-003	Polished or Black Finish of (F-3D-, F-1X, F-2) 10.5" Models (at time of purchase)	\$525
PC016A-004	Polished or Black Finish of (F-3R-) 12" Models (at time of purchase)	\$635
PC016A-006	Polished Finish of RaceDrive Models (at time of purchase)	\$1,100

## LOOKING FOR PARTS, ACCESSORIES, & RACE PRODUCTS?

### SHOP THE \*NEW\* PROCHARGER PARTS & RACING GUIDE

Shop online at [PROCHARGER.COM](http://PROCHARGER.COM) or request a "ProCharger Parts & Racing Guide" catalog, free of charge.

For questions, email our technical service team at [ts@procharger.com](mailto:ts@procharger.com)

Parts • Superchargers • Intercoolers • Accessories • Merch • Race Products

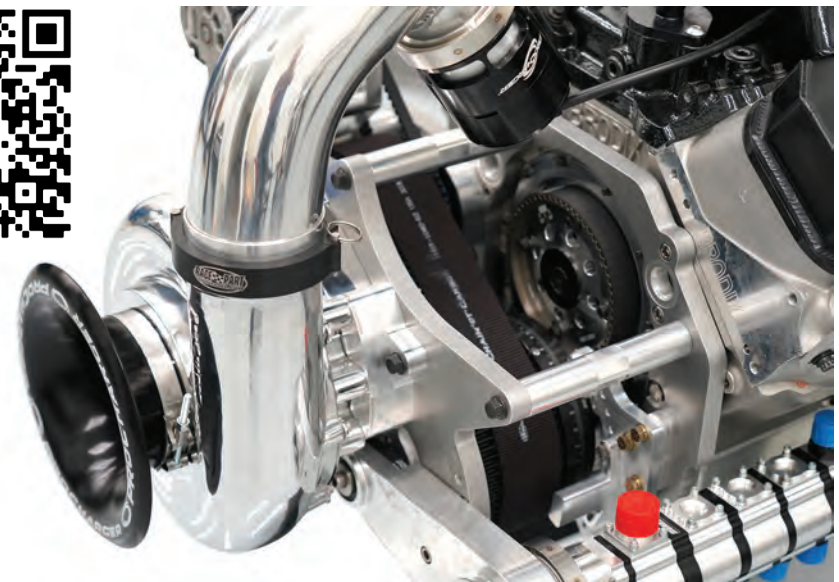

### DIGITAL & PRINT

ProCharger's industry leading catalogs are available for download at [ProCharger.com](http://ProCharger.com), or request a printed version free of charge.



### MERCH

Race over to our online store and show your ProCharger pride with a great selection of ProCharger merch!



**AIR-TO-AIR S/M**

Opposite Inlet/Outlet, Cross-flow

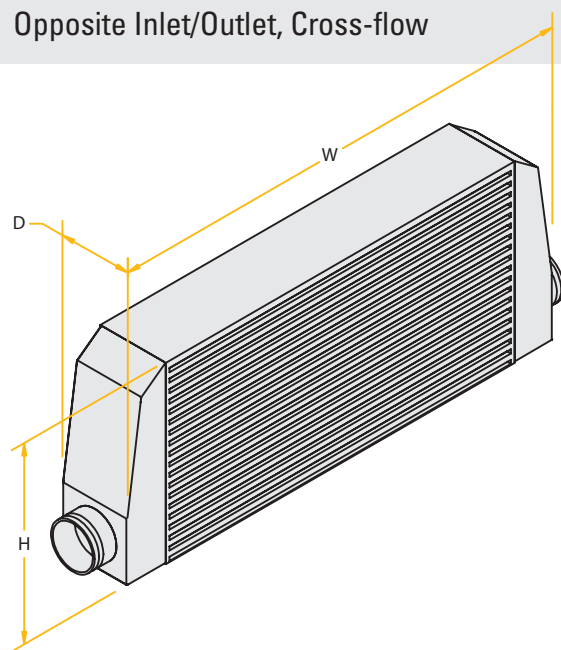

**AIR-TO-AIR S/M**

Opposite Inlet/Outlet, Cross-flow

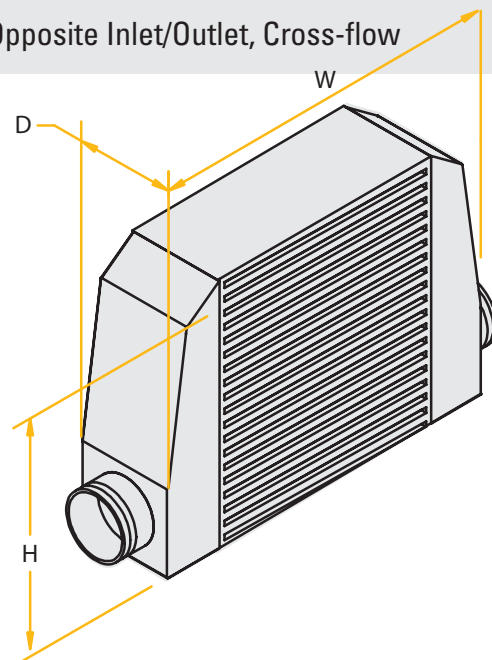

**AIR-TO-AIR S/M**

Opposite Side Inlet/Outlet

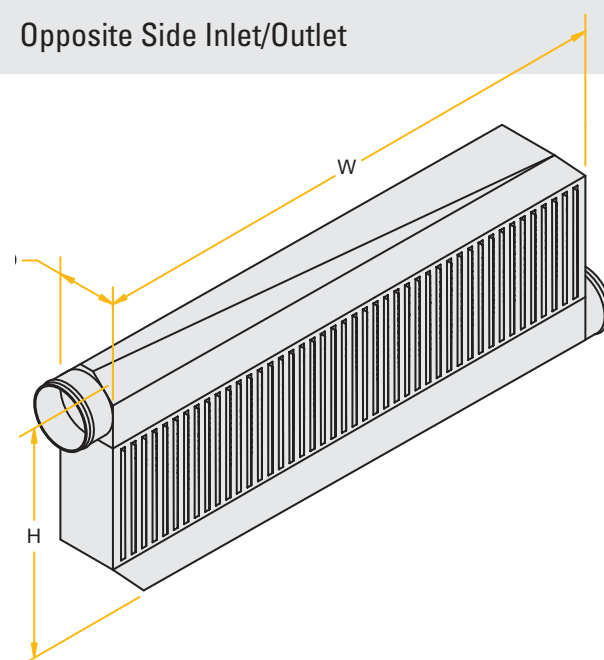

**AIR-TO-AIR S/M**

Top and Side Inlet/Outlet

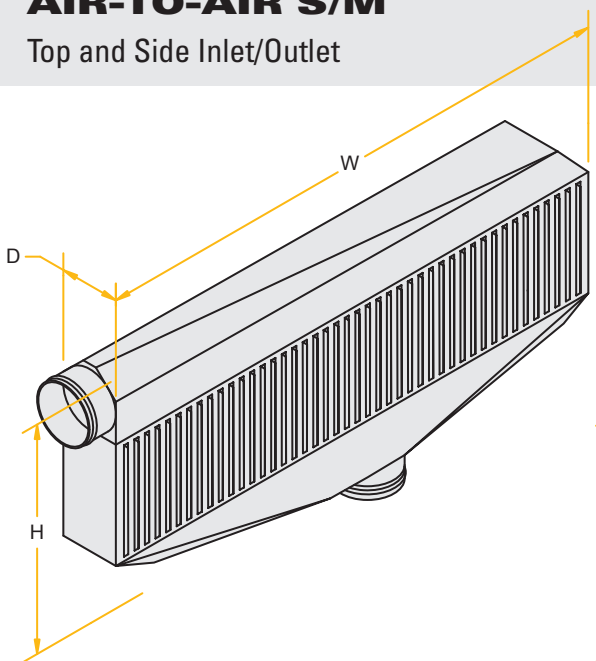

**AIR-TO-AIR S/M**

Same Side Inlet/Outlet

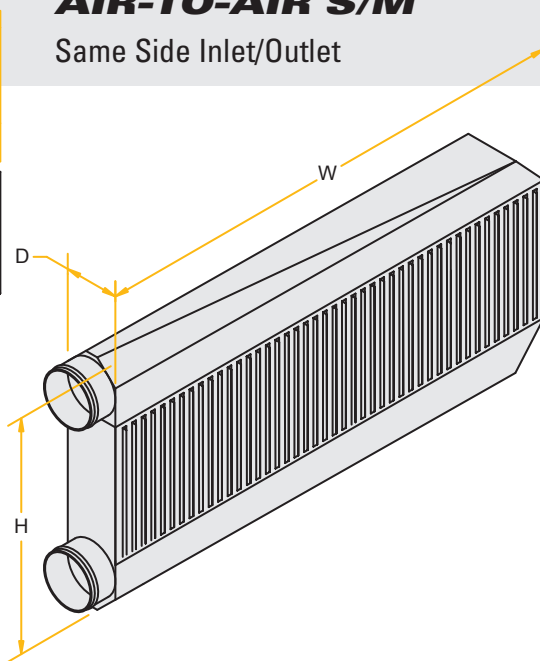

**AIR-TO-AIR TWIN**

Front and Side Inlet/Outlet

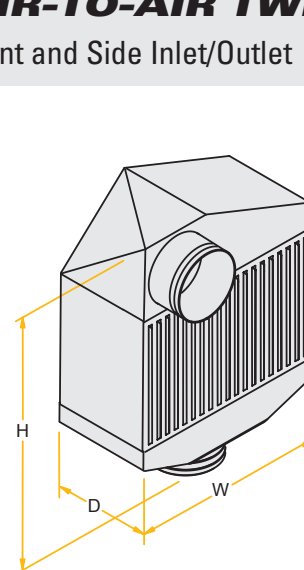

**AIR-TO-WATER**

Same Side Inlet/Outlet

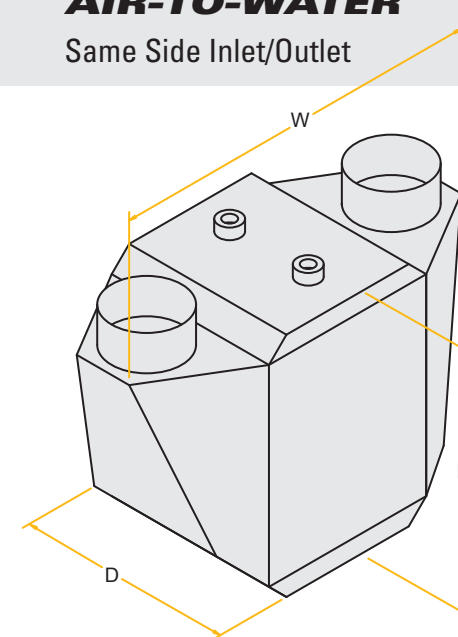



Use this intercooler chart for dimensions of the various intercooler types and inlet/outlet positions shown below. Dimensions are approximate.

### AIR-TO-AIR INTERCOOLERS

Part #	End Tank Type	In/Out Location	In/Out DIA.	Max HP	Core Width	Height	Depth	Price/MAP
AI002A-001	Sheet Metal	Opposite Sides	3"	500	18	12.5	3	\$898
AIFP1A-004	Sheet Metal	Opposite Sides	3"	500	18	12.5	3.5	\$898
AIFP1A-001	Sheet Metal	Opposite Sides	3"	650	24	12.5	3.5	\$1,198
AI003A-001	Sheet Metal	Opposite Sides	3"	825	27	12.5	3	\$1,198
AI003A-002	Sheet Metal	Opposite Sides	3"	950	27	15	3	\$1,398
AIDD1A-071	Sheet Metal	Opposite Sides	3"	1000	24	20	3	\$1,498
AI003A-005	Sheet Metal	Opposite Sides	3.5"	1050	27	15	3	\$1,498
AI045A-001	Sheet Metal	Opposite Sides	3.5"	1300	27	12	4.5	\$1,798
AI006A-001	Sheet Metal	Opposite Sides	4"	1550	27	12	6	\$2,298
AJK1A-002	Sheet Metal	Opposite Sides Cross Flow	3"	375	18	11	3	\$1,198
AIFR1A-010	Sheet Metal	Opposite Sides Cross Flow	3"	650	29	12	3.5	\$1,198
AIGN2A-011	Sheet Metal	Opposite Sides Cross Flow	3"	800	29	12	4.5	\$1,398
AIFW1A-035	Sheet Metal	Opposite Sides Cross Flow	3.5"	1200	20	17.5	4.5	\$1,498
AIGU1A-001	Sheet Metal	Front, Cross Flow	3"	1000	34	9	4.5	\$1,398
AIDD1A-015	Sheet Metal	Top/Side	3"	750	24	17	3	\$1,198
AIGO3A-001	Sheet Metal	Top/Side	3"	1050	27	13	3.5	\$1,398
AIGO3A-003	Sheet Metal	Top/Side	3.5"	1300	27	12	4.5	\$1,498
AIGO3A-004	Sheet Metal	Top/Side	3.5"/4"	1300	27	12	4.5	\$1,598
AI002A-003	Sheet Metal	Same Side	3"	500	18	12.5	3	\$998
AIGN1A-001	Sheet Metal	Same Side	3"	600	18	12.5	3.5	\$998
AI003A-003	Sheet Metal	Same Side	3"	825	27	12.5	3	\$998
AI003A-004	Sheet Metal	Same Side	3"	950	27	15	3	\$1,398
AIDG1A-073	Sheet Metal	Same Side	3"	1000	24	20	3	\$1,498
AI003A-006	Sheet Metal	Same Side	3.5"	1050	27	15	3	\$1,398
AI045A-002	Sheet Metal	Same Side	3.5"	1300	27	15	4.5	\$2,198
AI006A-002	Sheet Metal	Same Side	4"	1550	27	12	6	\$2,398

### AIR-TO-AIR TWIN INTERCOOLERS

Part #	End Tank Type	In/Out Location	In/Out DIA.	Max HP	Width	Height	Depth	Price/Map ea.
AIGB1A-XXX	Twin Sheet Metal	Opposite Sides	2"	500 Per Pair	9	10.5	3	\$798
AIGA1A-XXX	Twin Sheet Metal	Opposite Sides	2.5"	750 Per Pair	9	11	3.5	\$798
AIGK1A-XXX	Twin Sheet Metal	Front/Side	3"	850 Per Pair	9	11	4.5	\$898

### AIR-TO-WATER INTERCOOLERS

Part #	End Tank Type	In/Out Location	In/Out DIA.	Max HP	Width	Height	Depth	Price/MAP
AIGU1I-123	Sheet Metal/Billet	Same Side	3.5"	1500	12.5	10	12	\$1,698
W11005A-003	Sheet Metal	Same Side	3.5"	1500	13	11	9	\$1,898
W11005A-001	Sheet Metal	Same Side	4"	1800	9	13	19	\$2,498
W11005A-002	Sheet Metal	Same Side	4"	2400	13	13	23	\$2,998

\*\* Note: add approximately 2" to the above measurements to the side(s) that have the air inlets/outlets

# PROCHARGER<sup>®</sup>

SUPERCHARGER SYSTEMS

## THE ULTIMATE POWER ADDER<sup>®</sup>

ProCharger Headquarters  
Kansas City



ProCharger Office  
San Francisco



FOLLOW US



**#PROCHARGER**

CALL OR EMAIL

Sales/Service Phone Hours: 8:00 am–5:30 pm CST (M-F)  
Sales Email Address: [sales@procharger.com](mailto:sales@procharger.com)  
Technical Service Email: [ts@procharger.com](mailto:ts@procharger.com)  
Customer Service Email: [cs@procharger.com](mailto:cs@procharger.com)



14801 W. 114TH TERR LENEXA, KS 66215 • PH: (913) 338-2886 • FX: (913) 338-2879

[WWW.PROCHARGER.COM](http://WWW.PROCHARGER.COM)

