



Pella Installation Instructions

BLOCK FRAME ENTRY DOORS WITH OR WITHOUT BRICKMOULD

THE FOLLOWING INSTALLATION METHODS ARE INCLUDED IN THIS BOOKLET:

New Construction Installation Block Frame Entry Doors in Wood Framed Walls After Building Wrap With or Without Brickmould

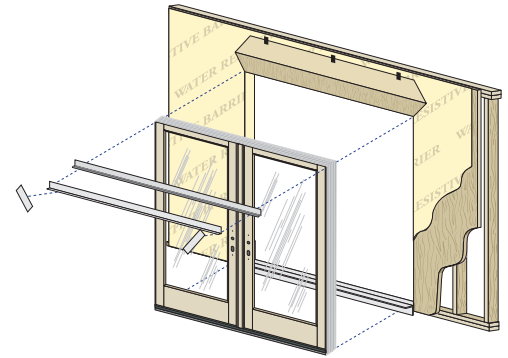

New Construction Installation in Masonry Construction for Block Frame Entry Doors With or Without Brickmould

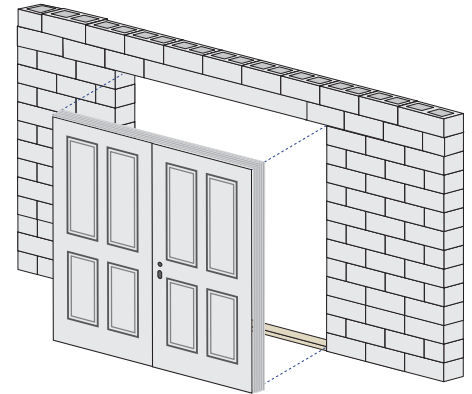

Full Frame Replacement without Disturbing Brick or Siding for Block Frame Entry Doors With or Without Brickmould

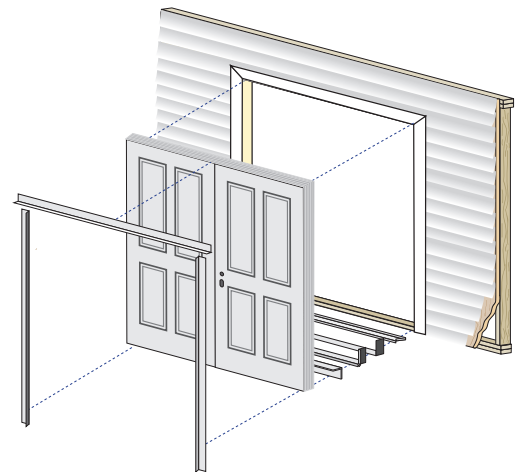

These instructions were developed and tested for use with wall systems designed to manage water. *These instructions are not to be used with any other construction methods or door frame types.* Installation instructions for use with other construction methods or frame types may be obtained from Pella® Corporation, your local Pella retailer or www.installpella.com. Building designs, construction methods, building materials, and site conditions unique to your project may require an installation method different from these instructions and/or additional care. Determining the appropriate installation method is the responsibility of you, your architect, or construction professional.



BY PURCHASING, INSTALLING OR USING PELLA PRODUCTS (INCLUDES PELLA GOODS AND PELLA SERVICES), YOU AGREED TO THE TERMS OF THE LIMITED WARRANTY AND YOU AND PELLA FURTHER AGREE TO ARBITRATE DISPUTES ARISING OUT OF OR RELATING TO PELLA PRODUCTS, AND YOU WAIVE ANY RIGHT TO PARTICIPATE IN A CLASS ACTION RELATED TO PELLA PRODUCTS unless you notify Pella of your decision to opt out of the Arbitration Agreement no later than ninety (90) calendar days from the date you purchased or otherwise took ownership of Your Pella Goods. Opting out of the Arbitration Agreement will not affect the coverage provided by any applicable limited warranty pertaining to Your Pella Products. For opt out information and additional details please read the Limited Warranty and Arbitration Agreement for your Pella Products at www.Pella.com/arbitration



IMPORTANT SAFETY AND PRODUCT INFORMATION – ENTRY DOORS

CAUTION: Many doors in older homes are painted with lead-based paint. Removal of old doors may disturb this paint. Proper precautions must be taken to minimize exposure to dust and debris. Consult state or local authorities and/or go to www.epa.gov/lead for more information.

 **WARNING:** To ensure safety and security and help prevent property damage, including possible damage to your window or door, close and lock windows and doors any time they are not being used for venting on a nice day, and particularly during high winds or rain.

IMPORTANT NOTICE

Because all construction must anticipate some water infiltration, it is important that the wall system be designed and constructed to properly manage moisture. Pella Corporation is not responsible for claims or damages caused by anticipated and unanticipated water infiltration; deficiencies in building design, construction and maintenance; failure to install Pella products in accordance with Pella's installation instructions; or the use of Pella products in wall systems which do not allow for proper management of moisture within the wall systems. The determination of the suitability of all building components, including the use of Pella products, as well as the design and installation of flashing and sealing systems are the responsibility of the Buyer or User, the architect, contractor, installer, or other construction professional and are not the responsibility of Pella.

Pella products should not be used in barrier wall systems which do not allow for proper management of moisture within the wall systems, such as barrier Exterior Insulation and Finish Systems (EIFS) (also known as synthetic stucco) or other non-water managed systems. Except in the states of California, New Mexico, Arizona, Nevada, Utah and Colorado, Pella makes no warranty of any kind on and assumes no responsibility for Pella windows and doors installed in barrier wall systems. In the states listed above, the installation of Pella Products in barrier wall or similar systems must be in accordance with Pella's installation instructions. Product modifications that are not approved by Pella Corporation will void the warranty.

CARE AND MAINTENANCE

Care and maintenance information is available by contacting your local Pella retailer. This information is also available at www.pella.com.

CLEANING INSTRUCTIONS

GLASS: Remove any protective film and labels and clean the glass, using a soft, clean, grit-free cloth and mild soap or detergent. Be sure to remove all liquid by wiping dry or use a clean squeegee.

FACTORY FINISHED PRODUCT: Pella Product that has been prefinished with stain or paint from the factory requires no additional finishing. Clean the surface with mild soap and water.

NOTICE: DO NOT use inappropriate solvents or brickwash or cleaning chemicals. If you do, permanent damage can result and the product failure, loss or damage would not be covered by the Limited Warranty.

FINISHING INSTRUCTIONS (SEE PAGE 15 FOR COMPLETE INSTRUCTIONS.)

Paint or finish immediately after installation.

If products cannot be finished immediately, cover with clear plastic to protect from dirt, damage and moisture. Remove any construction residue before finishing. Sand all wood surfaces lightly with 180 grit or finer sandpaper. DO NOT use steel wool. BE CAREFUL NOT TO SCRATCH THE GLASS. Remove sanding dust. Pella products must be finished according to these instructions; failure to follow these instructions voids the Limited Warranty. Finishing panel edges is optional for Patio Doors.

Note: To maintain proper product performance do not paint, finish or remove the weatherstripping, mohair dust pads, gaskets or vinyl parts. Air and water leakage will result if these parts are removed. After finishing, allow venting Doors and doors to dry completely before closing them. If paint, stain or finish gets on the weatherstripping, wipe it off immediately with a damp cloth.

EXTERIOR FINISH OF EXISTING FRAME (POCKET REPLACEMENT)

It is the responsibility of the homeowner, contractor or installer to ensure any exposed unfinished wood is covered or finished. Possible methods include, however are not limited to, covering with aluminum coil stock or painting.











FULL FRAME REMOVAL WHEN PREPARING TO INSTALL NEW BLOCK FRAME ENTRY DOOR

This method of Full Frame Removal involves removing the sash and entire frame of the existing door from the wall. The resulting opening is the original rough opening. The existing door nailing fins are usually nailed to the studs in frame construction with siding, brick veneer or other exterior material applied over the fin on the outside. The interior may have a drywall return from the wall to the door frame.

CAUTION: Many doors in older homes are painted with lead-based paint. Removal of old doors may disturb this paint. Proper precautions must be taken to minimize exposure to dust and debris. Consult state or local authorities for more information and/or go to www.epa.gov/lead for more information.

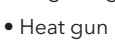
TOOLS REQUIRED:

- Utility knife 
- Pry bar 
- Hammer 
- Deglazing wheel 
- Phillips and Standard screwdrivers 
- Reciprocating saw 
- Putty knife 
- Heat gun 
- Angle Grinder with cutting wheel 

**REMEMBER TO USE APPROPRIATE PERSONAL PROTECTIVE EQUIPMENT.
APPLY ADHESIVE FILM OR DUCT TAPE TO THE GLASS TO PREVENT BREAKAGE.**

- A. **Score the paint or varnish** between the interior trim and the wall or between the drywall return and the doorframe to minimize damage.
- B. **Remove the interior trim.**

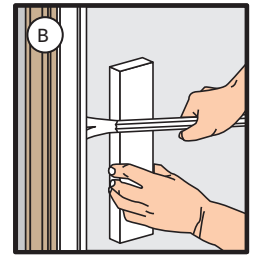

To collapse aluminum frames follow steps C-M.

To cut vinyl, clad wood, or aluminum frames out of the opening, see steps M and N.

- C. **Score the sealant** or paint between the exterior siding or brick and the door frame.
- D. **Remove the screen and vent panel** from the old door. If it is not removable, see steps G-I.
- E. **Remove the division bar** or astragal (if applicable) by removing the screws at the ends or cutting it with a reciprocating saw.
- F. **Remove the other panel.** Remove any screws holding the fixed panel. Slide and lift out of the channel (sliding doors) or remove hinge screws or hinge pins (hinge doors).
- G. **Remove any screws** securing the frame or strikes to the opening.

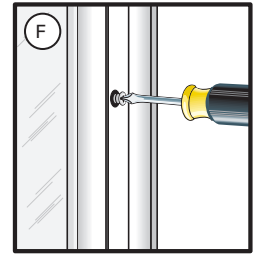
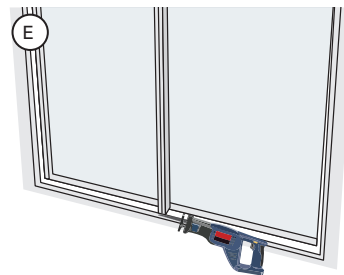

If the fixed panel is not removable or the glass is sealed to the frame:

- H. **Remove the glazing bead** using a putty knife or small pry bar.
- I. **For single pane doors with divided lights (grids):** Use an angle grinder with a cut-off wheel to cut the end of the bars where they intersect with the sash or frame. This will allow the doorglass to be removed more quickly.
- J. **Heat the glazing seal** using an electric heat gun.
- K. **While applying heat,** press a de-glazing wheel between the glass and sash or frame. Continue around the perimeter of the sash or panel. Apply light, constant pressure to separate the glass from the sash or frame. Dispose or recycle the glass properly.

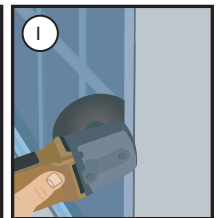
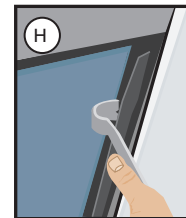

Note: Wear appropriate personal protective equipment and keep the heat source away from flammable materials.

- L. **Pry the frame away from the brick or siding.** Use a block of wood under the pry bar to protect interior or exterior finishes.
- M. **Cut through the frame using a reciprocating saw.** Dispose or recycle the frame materials properly.

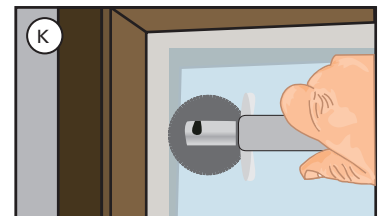
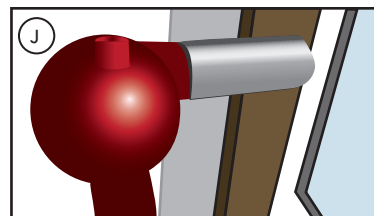

Cutting out vinyl, clad wood or aluminum frames:

- N. **Temporarily pry any head flashing up** to avoid damaging or cutting it.
- O. **Cut through the sealant line** and nailing fin across the top and sides of the door. Ensure the blade does not penetrate the interior where damage can occur to the drywall.

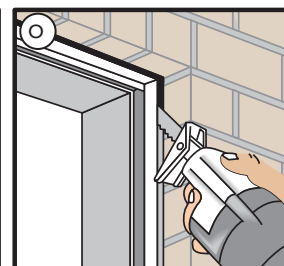
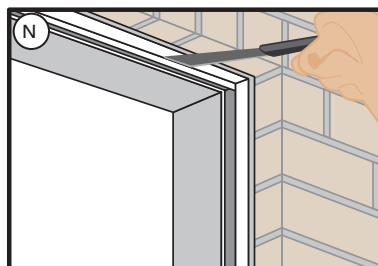
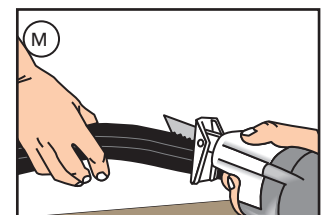
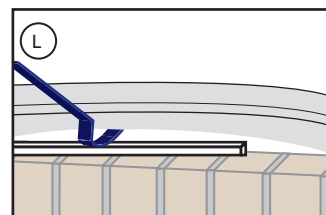





Consult with local providers and authorities to recycle or properly dispose of old door components.











PREPARING FOR BLOCK FRAME ENTRY DOOR INSTALLATION

YOU WILL NEED TO SUPPLY:

- Moisture resistant shims/spacers 
- Fasteners (see block frame anchor instructions at the end of this booklet)
- Closed cell foam backer rod/sealant backer 
- Pella® SmartFlash™ foil backed butyl door and door flashing tape or equivalent 
- Low expansion, low pressure polyurethane insulating door and door foam sealant
DO NOT use high pressure or latex foams. 
- Pella Door and Door Installation Sealant or equivalent high quality, multi-purpose sealant 

TOOLS REQUIRED:

- Tape measure 
- Level 
- Square 
- Hammer 
- Scissors or utility knife 
- Small flat blade screwdriver 
- Sealant Gun 
- Screw Gun with a Phillips Driver bit 

OTHER CONSTRUCTION MATERIALS MAY BE REQUIRED. READ AND UNDERSTAND THE INSTRUCTIONS AND INSPECT THE WALL CONDITIONS BEFORE YOU BEGIN.

INSTALLATION WILL REQUIRE (2) OR MORE PERSONS FOR SAFETY REASONS.

Store doors in upright position, out of direct sunlight.

PREPARE THE DOOR FOR INSTALLATION

- Remove plastic wrap and cardboard packaging from the door.** DO NOT open the door until it is securely fastened.
DO NOT cut the strap that goes from the lock holes to the sill of the door (if applicable).
- Inspect the product for any damage** such as cracks, dents or scratches. DO NOT install damaged products.
- Read the entire instruction before proceeding.**

These instructions were developed and tested for use with wall systems designed to manage water. *These instructions are not to be used with any other construction methods or doorframe types.* Installation instructions for use with other construction methods or frame types may be obtained from Pella® Corporation, your local Pella retailer or www.installpella.com. Building designs, construction methods, building materials, and site conditions unique to your project may require an installation method different from these instructions and/or additional care. Determining the appropriate installation method is the responsibility of you, your architect, or construction professional.



BY PURCHASING, INSTALLING OR USING PELLA PRODUCTS (INCLUDES PELLA GOODS AND PELLA SERVICES), YOU AGREED TO THE TERMS OF THE LIMITED WARRANTY AND YOU AND PELLA FURTHER AGREE TO ARBITRATE DISPUTES ARISING OUT OF OR RELATING TO PELLA PRODUCTS, AND YOU WAIVE ANY RIGHT TO PARTICIPATE IN A CLASS ACTION RELATED TO PELLA PRODUCTS unless you notify Pella of your decision to opt out of the Arbitration Agreement no later than ninety (90) calendar days from the date you purchased or otherwise took ownership of Your Pella Goods. Opting out of the Arbitration Agreement will not affect the coverage provided by any applicable limited warranty pertaining to Your Pella Products. For opt out information and additional details please read the Limited Warranty and Arbitration Agreement for your Pella Products at www.Pella.com/arbitration



NEW CONSTRUCTION INSTALLATION WITH BRICKMOULD AFTER BUILDING WRAP

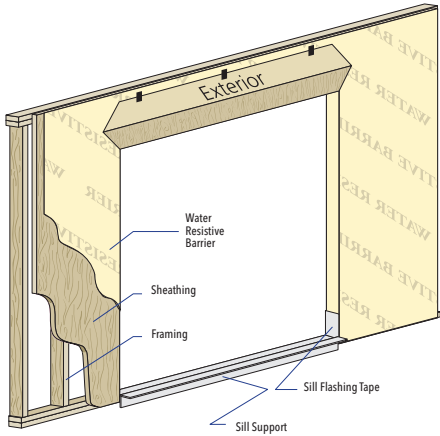

1 PREPARE THE OPENING

REFER TO THE INSTALLATION PREPARATION SECTION AT THE BEGINNING OF THIS BOOKLET.

A. Cut the building wrap.

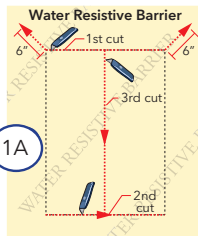

B. Fold the building wrap in at the jambs and staple it in place. Fold the top flap up and temporarily fasten with flashing tape.

If using an optional sill pan, refer to the sill pan instruction page at the end of this booklet.

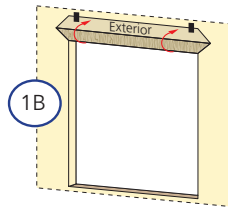

C. Cut 2 pieces of flashing tape 12" longer than opening width.

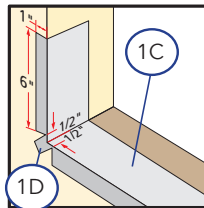

D. Apply sill flashing tape #1 at the sill extending 1" to the exterior and 6" up each jamb.

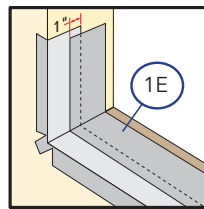

E. Cut 1" wide tabs at each corner by tearing the foil 1/2" each way from corner.

F. Apply sill flashing tape #2 overlapping tape #1 by 1" minimum.

Note: For In-Swing Doors with frame depth greater than 5", add a third piece of flashing tape so it comes within 1/4" of the interior of the door frame.

Note: Press all tape down firmly.

G. Attach a Pella aluminum sill support or wood blocking flush with the opening sill.

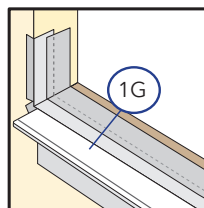

NEW CONSTRUCTION INSTALLATION IN MASONRY CONSTRUCTION FOR BLOCK FRAME DOORS

For the installation of new block frame doors into masonry openings.

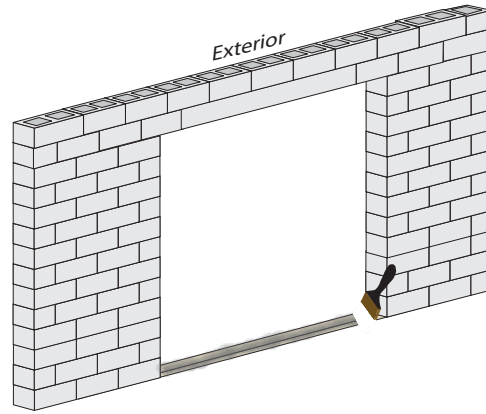

1 PREPARE THE OPENING

REMEMBER TO USE APPROPRIATE PERSONAL PROTECTIVE EQUIPMENT.

A. Clean the opening. Ensure it is dry and free from dirt, oil and debris.

B. Apply water resistant coating to the masonry. Extend the coating into the opening on all four sides. The water resistant coating may be a self-adhered sheet membrane (SASM) or a liquid applied flashing. Ensure continuity between the water resistant coating in the opening and the rest of the wall surface. SASM's must be overlapped in a water shed fashion. Apply all water resistant coatings according to the manufacturer's directions.

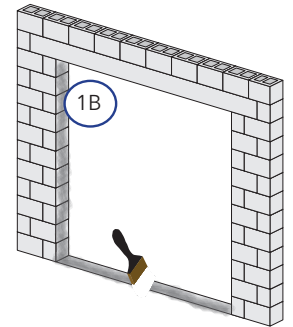

C. Measure the width and height of the opening. The new door must be 1/2" to 3/4" smaller in width and 3/8" to 1/2" small in height than this measurement.

D. Confirm the opening is plumb, level and square.

E. Measure and mark the opening where the interior of the new door will be placed. Consider the size of wall cavity (if applicable) and 3/4" minimum overlap onto the brick veneer or finished wall materials for exterior perimeter sealant.

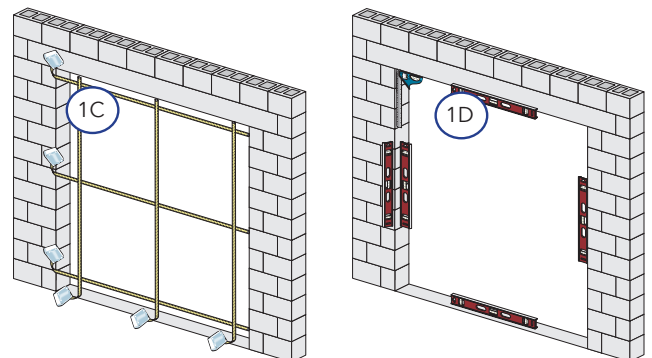

If using an optional sill pan, refer to the sill pan instruction page at the end of this booklet.



FULL FRAME REPLACEMENT WITHOUT DISTURBING BRICK OR SIDING FOR BLOCK FRAME DOORS

For use in brick or siding with trim/j-trim after the complete removal of a nail fin door

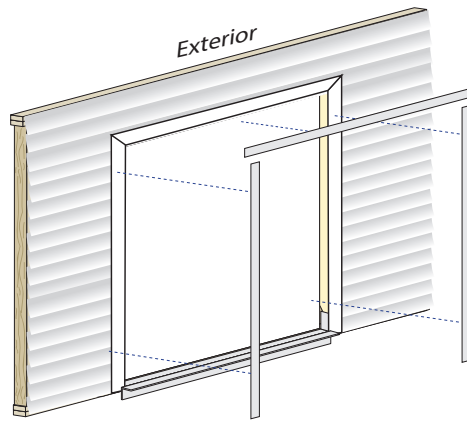
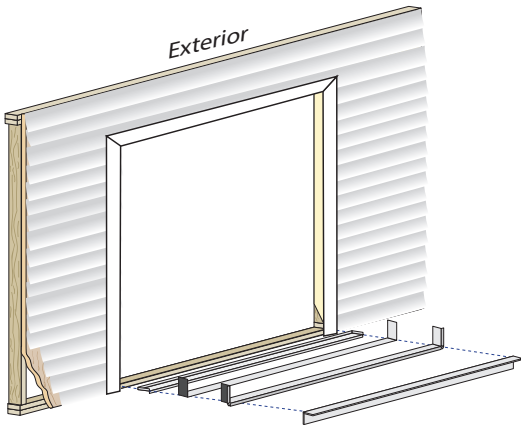

1 PREPARE THE OPENING

- A. **Clean the opening.** Ensure it is dry and free from dirt, oil and debris.
- B. **Measure the width and height of the opening.** The new door must be 1/2" to 3/4" smaller in width and 3/8" to 1/2" small in height than this measurement.
- C. **Confirm the opening is plumb, level and square.**

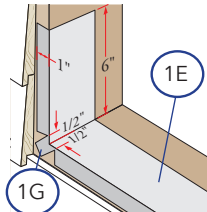

- D. **Measure and mark the opening** where the interior of the new door will be placed. Consider the size of wall cavity (if applicable) and 3/4" minimum overlap onto the brick veneer or finished wall materials for exterior perimeter sealant.
- If using an optional sill pan, refer to the sill pan instruction page at the end of this booklet.

- E. **Cut 2 pieces of flashing tape** 12" longer than opening width.
- F. **Apply sill flashing tape #1** at the sill extending 1" to the exterior and 6" up each jamb.
- G. **Cut 1" wide tabs** at each corner by tearing the foil 1/2" each way from corner.
- H. **Apply sill flashing tape #2** overlapping tape #1 by 1" minimum.

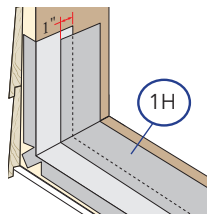

Note: For In-Swing Doors with frame depth greater than 5", add a third piece of flashing tape so it comes within 1/4" of the interior of the door frame.

Note: Press all tape down firmly.

- I. **Attach a Pella aluminum sill support or wood blocking** flush with the opening sill.

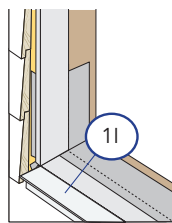

2 FLASH THE OPENING

Note: If there is an existing, functioning head flashing or if the opening is directly below a soffit or overhang, skip to step 3.

If building wrap exists at the head of the opening follow steps 2A-2C. If no building wrap exists, skip to step 2D.

- A. **Prepare a head flashing with upturned leg** by cutting it the same width as the brick/siding opening.
- B. **Pry the top (head) j-channel/siding away from the sheathing** enough so the head flashing can be slid under the house wrap.
- C. **Insert the head flashing** behind the brick/siding and behind the house wrap.

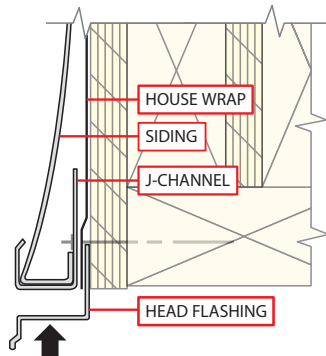

2 FLASH THE OPENING (CONTINUED)

NO BUILDING WRAP:

- D. **Prepare head flashing** with no up-turned leg by cutting it the same width as the brick/siding opening. The head flashing should not extend past the interior of the doorframe.

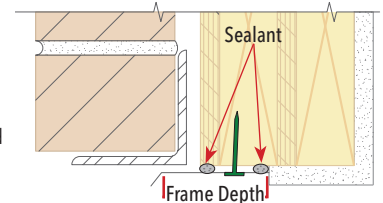

- E. **Apply (2) 3/16" beads of sealant.** One at the interior edge of the flashing and one along the exterior edge of the sheathing.
- F. **Apply a 3/16" bead of sealant** at each corner connecting the two beads from step 2E.
- G. **Secure the flashing** to the opening over the sealant using roofing nails or corrosion resistant pan head screws at 12" max. spacing.

Important: The flashing must slope to the exterior.

3 SEAL THE OPENING

- A. **Clean the siding J-channel/trim** or brick and rough opening thoroughly.
- B. **Apply a 3/8" bead of sealant** (or enough to cover the area) between the j-channel/trim and the sheathing at jambs (siding only). If a head flashing with upturned leg was used, seal between the back of the flashing and the sheathing at the head. Tool the sealant at head and/or jambs with a putty knife to press the sealant into the opening.
- C. **Place a 3/8" bead of sealant at each corner** of the opening.
- D. **Apply flashing tape** over the sealant at the head if a flashing with upturned leg was used. Extend the flashing tape 6" down each jamb. Cover the exterior surface of the drywall (if applicable).
- E. **For brick, apply low expansion foam** at the jamb to seal between the back of the brick and the sheathing.
- F. **For siding, apply flashing tape** at each jamb extending 3" onto the head and sill. Cover the exterior edge of the drywall (if applicable) and extend the tape over the sealant onto the side of the trim or j-trim.

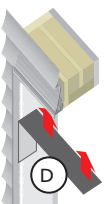
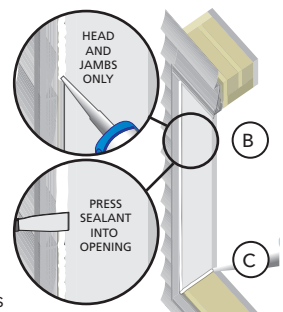

Note: The jamb flashing tape may also be used on brick. Apply sealant to the brick before application.

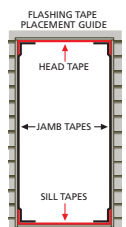
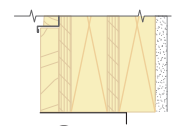
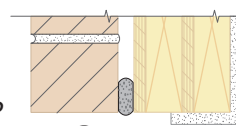



FULL FRAME REPLACEMENT, NEW CONSTRUCTION INSTALLATION WITH BRICKMOULD AFTER BUILDING WRAP & NEW CONSTRUCTION INSTALLATION IN MASONRY CONSTRUCTION FOR BLOCK FRAME DOOR

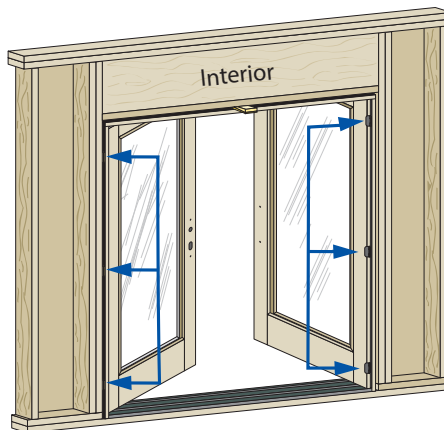
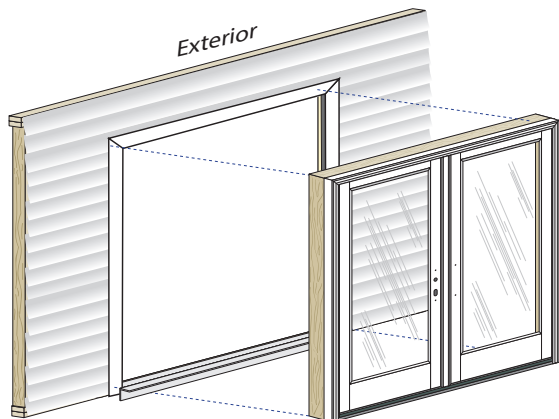

4 SET AND FASTEN THE DOOR

- A. Place three 3/8" beads of sealant across the opening sill.** Place the interior-most bead 1/2" from where the interior of the door sill will remain after installation. Continue this bead 6" up each jamb. Place a second bead 1/2" from the exterior of the framing. Place a 3rd bead in the groove of the sill support or 1/4" from the exterior edge of the sill.

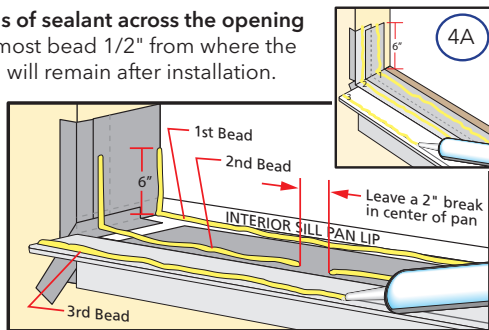

Variations in threshold design may require that the caulk lines be applied directly to the bottom of the door unit to ensure a necessary weather-seal. Inspect the bottom of door unit to confirm it features a flat surface before caulking the sub-floor area.

- B. Apply sealant to the back of the brickmould.**

- C. From the exterior; center the bottom of the door in the opening** and tilt the door into position. Do not slide the door into the opening. Sliding will damage the sealant lines. Tilt the door into position, making sure the interior face of the door frame aligns flush with the interior wall.

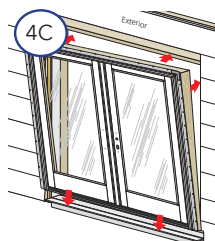

- D. Check the door placement** by measuring from the interior surface of the door frame or jamb extension to the interior surface of the wall for consistency.
- E. Pre-drill and drive two screws one near the top of each side of the door** through the frame. (See anchor instructions at the end of this booklet for screw spacing.)

- F. From the interior:** Plumb and square the door. Place shims tightly at the bottom corners of the door unit to keep the door centered and the frame tight against the sill. Keep shims 1/2" short of door frame depth.

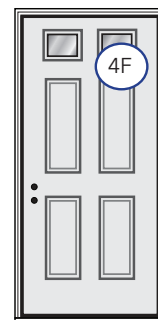
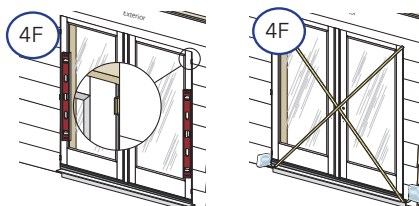
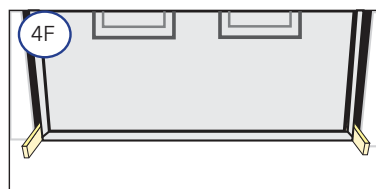

Note: Additional shims are required at screw locations for advanced performance, impact resistant units and combinations and combinations. (See the anchor instructions at the end of this booklet.)

- G. Shim the door frame at the top of each jamb.** This will hold the door tight in its position relative to the frame. The door should operate freely with nothing but shims holding it in place.

Note: Do not open the door panel greater than 30-degrees until all 2-1/2" screws have been installed.



4 SET AND FASTEN THE DOOR (CONTINUED)

- H. Place shims behind the vacant screw hole at each hinge until there is a consistent 1/8" gap between the hinge-side jamb and the door slab edge along the entire height of the door. Gap between the latch-side jamb and the door slab edge should be 1/8" at the top and bottom of the door only. Drive one of the 2-1/2" screws provided through the vacant hole in each hinge, through the jamb, shims and into the rough opening.

Brickmould should not be used to structurally fasten the door. Fasteners in the Brickmould should be used only to hold the Brickmould in place.

(See anchor instructions at the end of this booklet for screw spacing.)

Note: When the shims are properly installed, the frame should not move or twist at all when the screws are tightened and counter-sunk thereby maintaining the 1/8" gap. If there is any movement, loosen the screws and shim tighter to maintain the 1/8" gap, then re-tighten the screws.

- I. **Single Doors & Single Doors with Sidelight with multi-point locks;** Shim behind the lock side jamb approximately 8" from the top and bottom of the frame. Install shims until there is an even 1/8" gap between the jamb and the edge of the door slab along the door

Insert additional shims starting 6" from the bottom as needed to keep jambs straight with panel reveals even on all four sides.

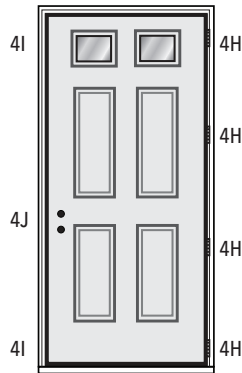

- J. Shim behind the lock side jamb just above and below the dead bolt hole, maintaining the 1/8" gap.

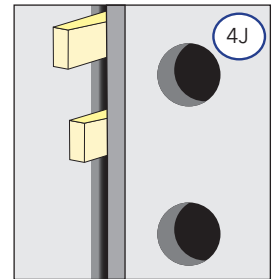

- K. Install 2-1/2" installation screws through the jamb and shims into the stud.
- L. Double Doors Only: Install 2-1/2" installation screws through the jamb and shims into the stud at the head aligned with the center of each panel.

FACTORY-FINISHED DOOR SYSTEM

If the inside of the jamb is not accessible, 1/8" holes must be drilled through the factory-finished exterior jamb, 1/4" deep at all points where the door system is shimmed (three on each exterior side of a non-operable panel. Drive 2-1/2" installation screws, through the drilled holes in the exterior thick (stop) section of the jamb, through the shims and into the studs. Some local building codes may require additional security screws through hinges and strikes.

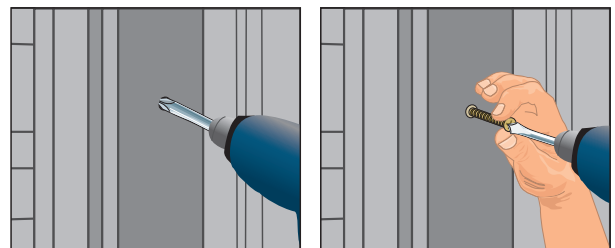

Drill holes through the exterior jamb on factory-finished jambs, install screws and fill in holes with fill stick provided in hardware bag.

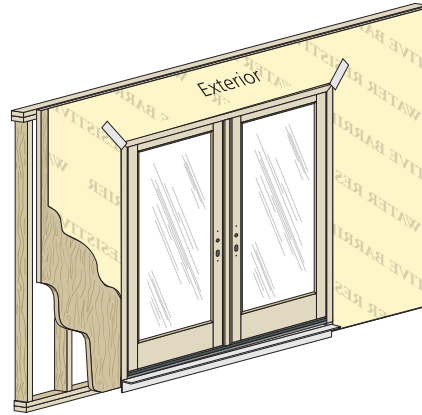
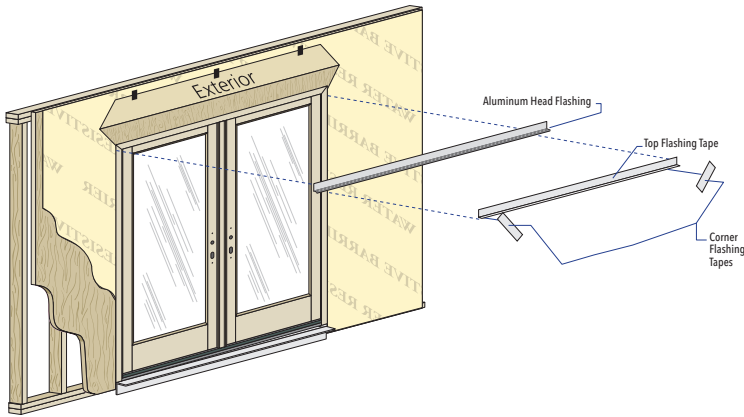

5 INTEGRATE WITH BUILDING WRAP

- A. Apply a bead of sealant along the top of the brickmould where it meets the wall. Continue the sealant along the edges of the brickmould to the front corner.
- B. Install Head Flashing by pressing it into the sealant and securing it to the wall using roofing nails.

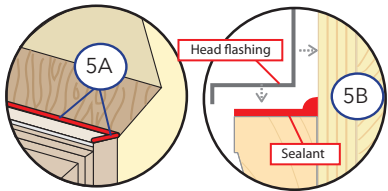

- C. Cut a piece of flashing tape 4" longer than the brickmould width.

- D. Apply the flashing tape over the head flashing and onto the sheathing so it extends past the brickmould 2" each side.

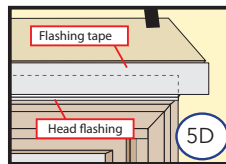

- E. Fold down top flap of weather resistive barrier.

- F. Apply flashing tape to top diagonal cuts. Cut pieces of flashing tape at least 1" longer than each diagonal cut. Lap tape 1" past end of cut onto weather barrier. Overlap multiple pieces of tape by 1" when necessary.

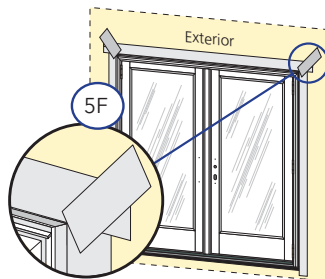

NOTE: PRESS ALL FLASHING TAPE DOWN FIRMLY.

- G. Install interior sealant. Refer to the interior sealant instructions at the end of this booklet.
- H. Install exterior sealant. (After wall cladding is installed) Refer to the exterior sealant instructions at the end of this booklet.



ANCHOR SCHEDULE - FRAME SCREW INSTALLATION FOR PELLA® ENTRY DOORS

Note: Additional anchoring may be required to comply with local building code requirements.

Anchor Location		Venting	Anchor Type		Instructions	Illustration
			Wood	Masonry		
Head	Frame-Screws	Fixed or Vent	#10 x 2-1/2" corrosion resistant	3/16" x 3" Masonry Screw	See Illustrations for spacing and placement.	E
	Frame	Door/Sidelight Combinations	#10 x 2-1/2" corrosion resistant	3/16" Masonry Screw	Pre-drill and install screws 3" and 6" on each side of each mullion end.	E
Jambs	Hinges	In-Swing and Out-Swing	#10 x 2-1/2" corrosion resistant			A
	Strike	Vent	#8 x 2-1/2"		Shim between each frame and rough opening at the strike and deadbolt.	C
	Frame-Screws	Fixed or Vent	#10 x 2-1/2" corrosion resistant	3/16" x 3" Masonry Screw	See Illustrations for spacing and placement. The weatherstrip may be temporarily moved to reveal the frame screw.	E
	1-Panel Frame	Vent	#10 x 2-1/2"		Pre-drill and install screw 6" below the top of the lock jamb.	D
Sill	Threshold	Door/Sidelight Combinations	#10 x 2-1/2" corrosion resistant	3/16" Masonry Screw	Pre-drill and install screws 3" and 6" on each side of each mullion end.	E
	Frame-Screws	Fixed or Vent	#10 x 2-1/2" corrosion resistant	3/16" x 3" Masonry Screw	See Illustrations for spacing and placement.	E
	Low-Profile	Vent	#10 x 2-1/2" corrosion resistant	3/16" x 3" Masonry Screw	For doors with standard locks, install tubs per instruction included with sill strike package	B

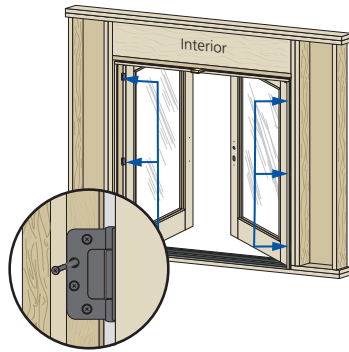

A

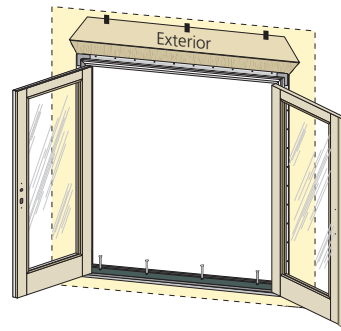

B

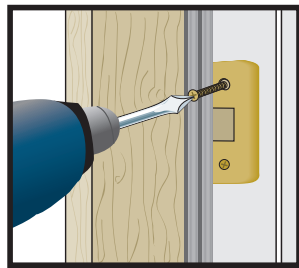

C

Entry Door

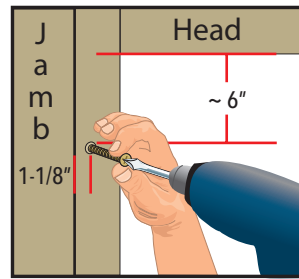

D

ILLUSTRATIONS CONTINUED ON NEXT PAGE



ANCHOR SCHEDULE - FRAME SCREW INSTALLATION FOR PELLA® ENTRY DOORS

Note: Additional anchoring may be required to comply with local building code requirements.

Screws located in hinge or strike position shall be placed in the thin (rabbet) section of frame, other screws shall be placed in thick (stop) section of frame. Wide frames should be attached with a screw in both sections of the frame to minimize rotation. DO NOT use brickmould for structural fastening.

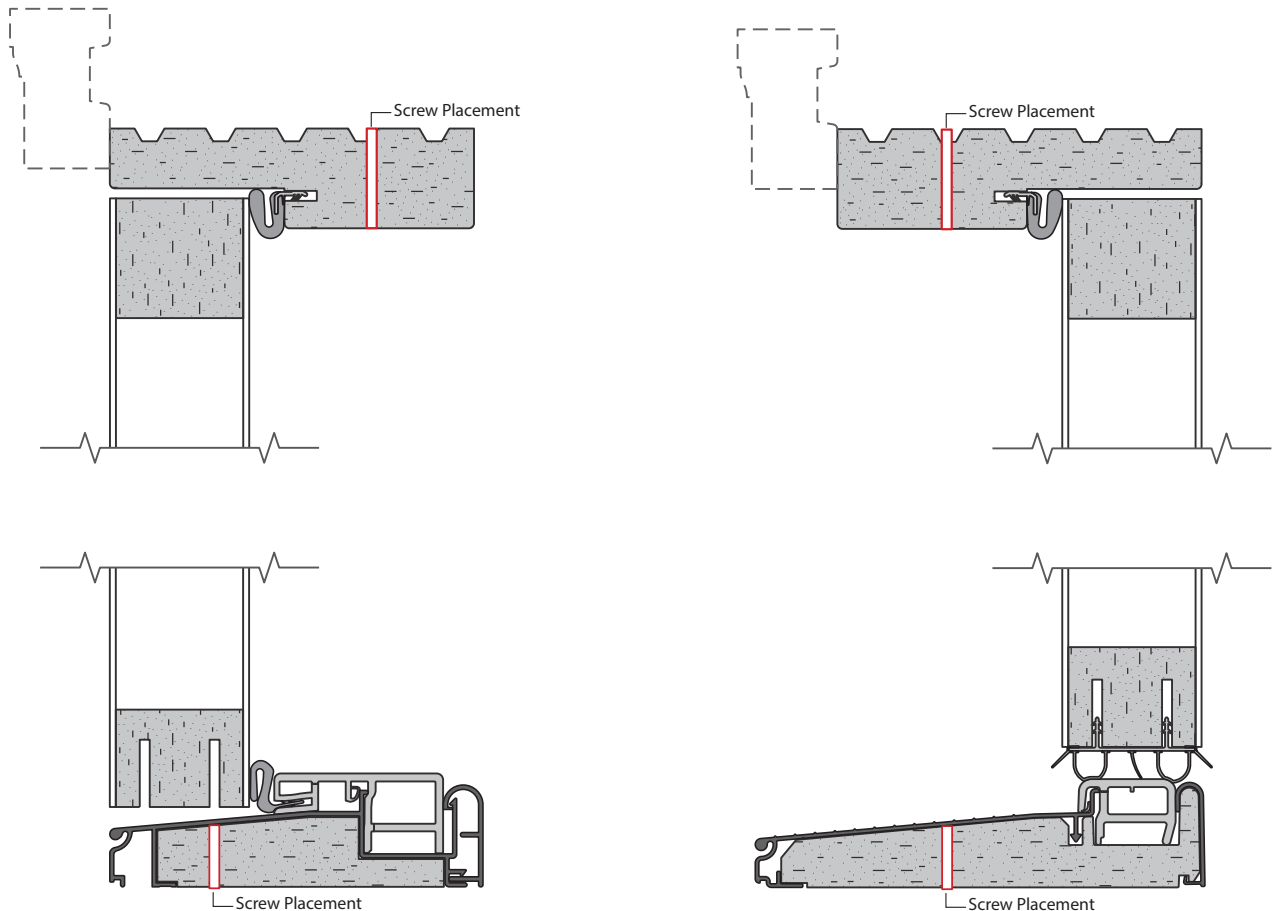

E



ANCHOR SCHEDULE - STRUCTURAL PERFORMANCE IMPACT-RESISTANT

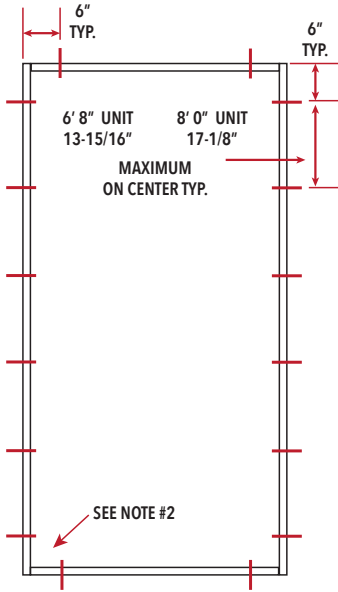

Minimum Fastener Count

- 2 per horizontal framing member
- 6 per vertical framing member

See notes for additional detail

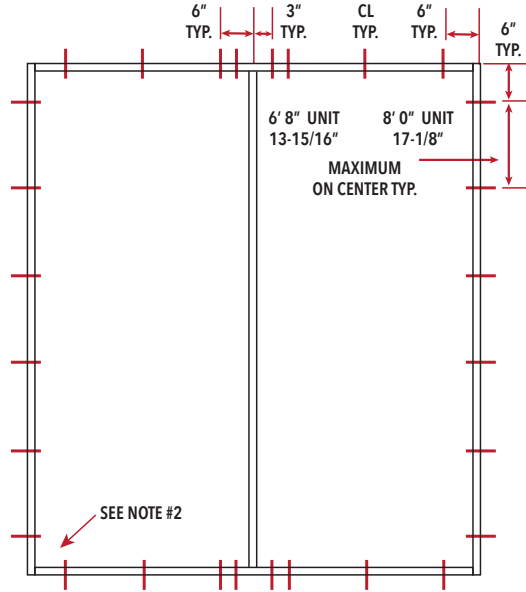

Minimum Fastener Count

- 8 per horizontal framing member
- 6 per vertical framing member

See notes for additional detail

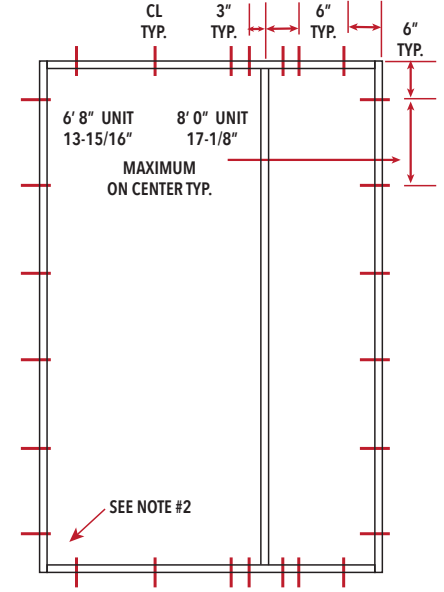

Minimum Fastener Count

- 7 per horizontal framing member
- 6 per vertical framing member

See notes for additional detail

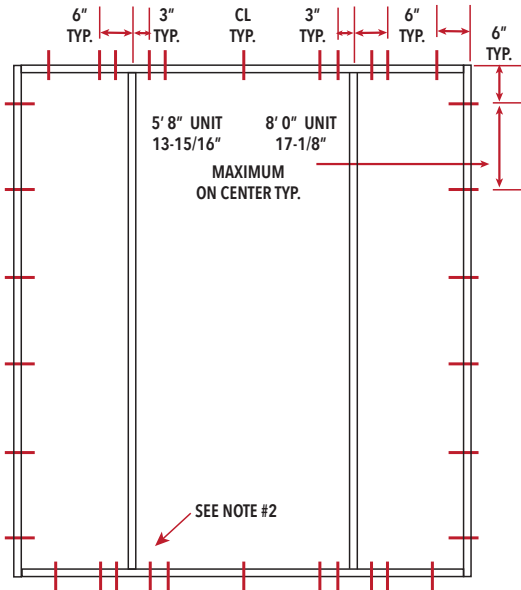

Minimum Fastener Count

- 11 per horizontal framing member
- 6 per vertical framing member

See notes for additional detail

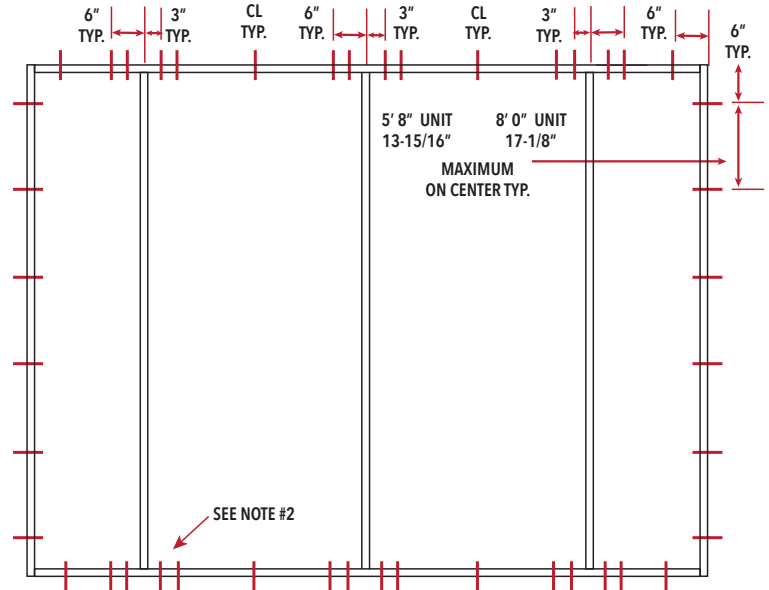

Minimum Fastener Count

- 16 per horizontal framing member
- 6 per vertical framing member

See notes for additional detail

NOTES:

1. Cylindrical and deadbolt hardware required at 5-1/2" centerline for 6'8" and smaller and 10-1/2" centerline for door heights greater than 6'8". Evaluated with Kwikset Series 400 latch and Series 980 deadbolt.
2. Fasteners analyzed for this unit include #10 wood screws (1-1/2" embedment) or 3/16" Tapcons (1-1/4" embedment).
3. One #10 x 2-1/2" screws required through each hinge on the vertical jamb or mullion.
4. Two #8 x 2" screws required through each strike plate.
5. Wood bucks by others, must be anchored properly to transfer loads to the structure.
6. Rough opening to accommodate no greater than 1/4" shim space.



Interior Sealant Instructions

CAUTION: Use low pressure polyurethane door and door insulating foams. Follow the directions on the can. Do not use high pressure or latex foams.

- A. Insert the nozzle or straw between the rough opening and door frame from the interior. Use a pliers (if necessary) to compress the end of a straw tube to allow it to fit in tight openings.
- B. Place a 1" deep bead of foam approximately 1" from the interior of the frame to allow for expansion. DO NOT fill the entire depth of the rough opening cavity.

Note: Apply foam between the frame and rough opening, NOT between jamb extensions and the rough opening.

- C. To ensure a continuous interior seal, apply sealant over the interior surface of any shims interrupting the foam seal. Backer rod (as necessary) and sealant can be used in place of the low expansion foam to create the interior seal. However, foam has greater insulating properties. Fiberglass batt or similar insulation is not recommended as it can absorb water and does not act as an air seal.
- D. Place a continuous bead of sealant across the inner sill at the intersection of the door sill and subfloor. Continue the sealant 6" up each jamb.

Note: Use a low odor, paintable sealant such as Pella Door and Door Installation Sealant.

Re-check door operation after foam installation. Excess foam may be removed with a serrated knife after it cures.

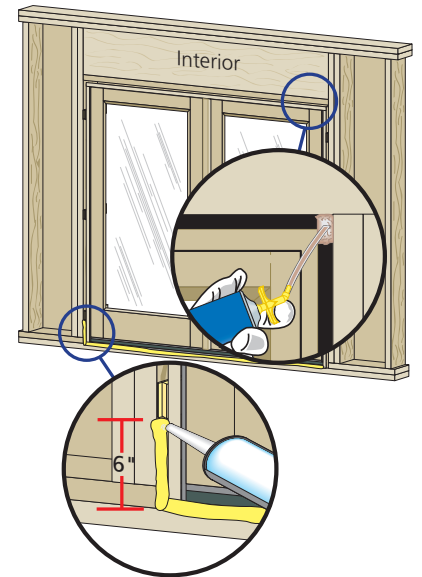

Brickmould Doors

- A. Insert backer rod 3/8" deep in the space around the door. Backer rod adds shape and controls the depth of the sealant line.
- B. Apply a continuous bead of sealant to the entire perimeter of the door.
- C. Shape, tool and clean excess sealant. When finished, the sealant should be the shape of an hourglass.

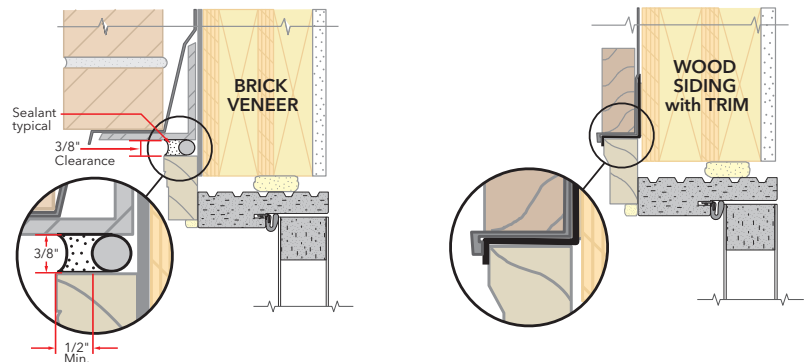

Threshold Adjustment

If door has an adjustable threshold at the sill: Check for sufficient weatherstrip contact between the bottom weatherstrip and the threshold. Close the door on a dollar bill or sheet of paper located above an adjustment screw; light friction should be felt when pulling the paper out indicating a good seal is being made. If there is not, adjust the threshold. Some sills may have covers over the adjusting screws. These covers must be removed prior to making any adjustments. Repeat for each adjustment screw. DO NOT raise the threshold height >1/4"!

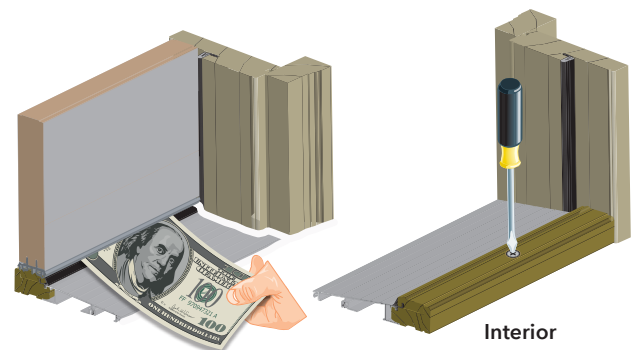



EXTERIOR SEALANT

CAUTION: Use a high quality, multi-purpose exterior sealant such as Pella Door and Door Installation Sealant. Follow the directions on the cartridge.

When applying siding, brick veneer, flashing, or other exterior finish materials, leave adequate space between the door frame and the material for sealant application of sealant.

- A. **Insert backer rod 3/8" deep** in the space around the door. Backer rod adds shape and controls the depth of the sealant line.
- B. **Apply a continuous bead of sealant to the entire perimeter of the door.**
- C. **Shape, tool and clean excess sealant.** When finished, the sealant should be the shape of an hourglass.

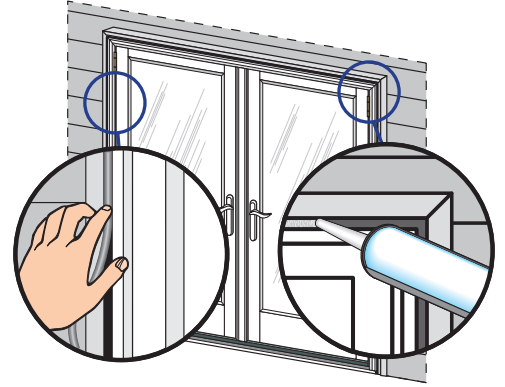

D. Apply sealant to all four exterior corners and all around the brick or siding in the following sequence:

- Apply sealant to the sill on both lock and hinge sides from the edge of the sill crown along the edge where the sill and jamb or brickmould meet.
- Apply sealant to the front sill edge where the sill and the sub-floor meet.
- Apply sealant to the top corners where the header and jambs meet, starting at the weatherstrip and working to the face of the brickmould.
- Apply sealant to the perimeter where the exterior trim meets the brick or siding trim. If the door is center-hinged or has a sidelight, apply sealant around the mullions where the mullions contact the sill and header.

Before the sealant sets up; remove paper backing from the corner seal pad and position the pad embedded in the sealant and tight against the top of the adjustable threshold, with the thin portion of the pad flush with the interior face of the jamb (both jambs).

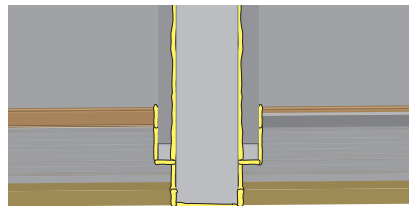
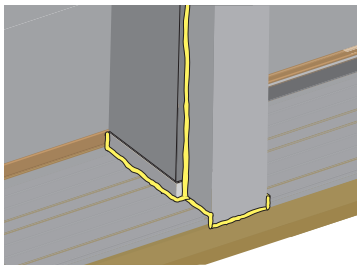
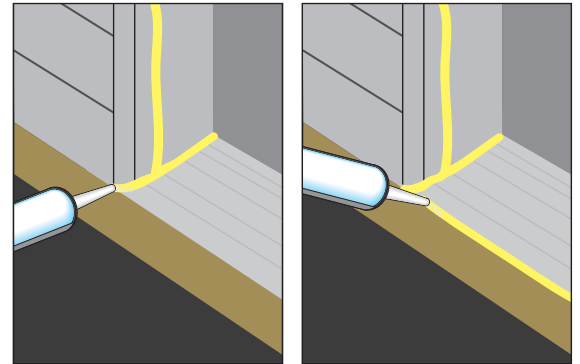

Front View

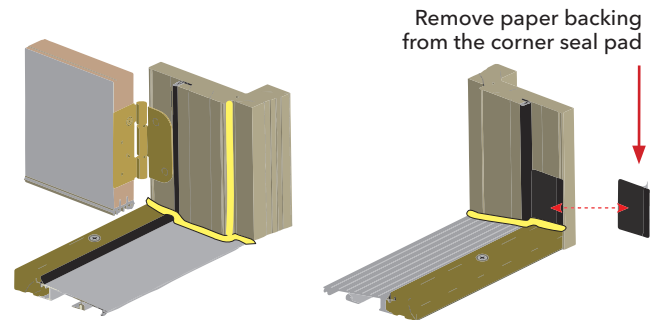
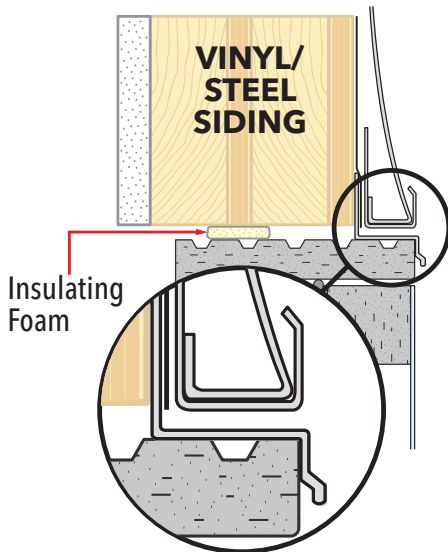
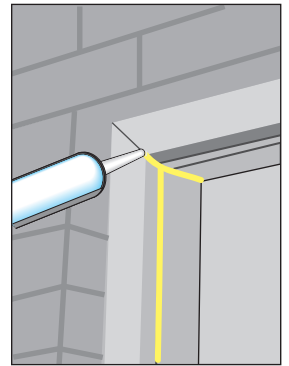
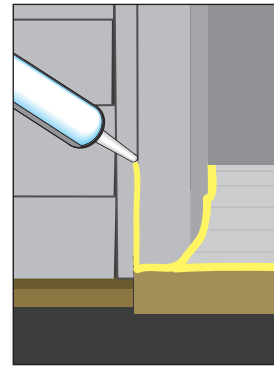



Factory finished door units do not require additional field finishing. See maintenance steps for proper care.

HOW TO STAIN WOODGRAIN TEXTURED FIBERGLASS DOOR PANELS AND FRAME COMPONENTS

REQUIREMENTS

Find a well-lit staining dust-free location, well ventilated and within the climate conditions.

Please read and understand the entire staining procedure before attempting to finish. Be sure to follow the stain and top-coat manufacturers detailed application instructions on the product label.

You will need the following:

COATINGS AND ACCESSORIES:

- Mineral spirits or acetone
- Lint-free rags or cheese cloth (recommended)
- Stain
 - High-quality, opaque (non-transparent), heavily pigmented, oil-based stain (recommended)
 - Gel stains can also be used
 - Semi-transparent stains are not recommended
- High-quality, exterior grade, UV stabilized polyurethane sealant (satin or low gloss)

TOOLS:

- Hammer
- Pin punch
- Screwdriver with arrangement of screw bits
- Pliers
- Safety glasses
- Rubber gloves
- Stir sticks
- 2" wide foam brush
- 2-1/2" wide china bristle brush
- Masking tape
- Safety razor blades

A. How to start

Door panels can be stained either hanging in the opening or removed from the frame (recommended). Take care to protect removed doors from damage. Sidelights will need to be finished vertically. To remove the door from the frame, use a pin punch and hammer. Strike the hinge pin from the bottom until it pops up (for out-swing units—hinge leaf must be removed from the door).

Drive the hinge pin as far as possible with the punch. Using a pair of pliers, grasp the hinge pin and, while twisting, pull the pin out. Remove all door panel hardware.

B. Preparing the door surface

Important: Dust, debris and other surface contaminants can accumulate on the surface of the door panel. Therefore, to achieve best results and maximum coating adhesion, wipe/clean all surfaces of the door thoroughly with acetone or mineral spirits. Do not sand Woodgrain texture. Mask (tape) off all surfaces that will not be stained. Weatherstrips should be masked or removed temporarily to protect from finish.

C. Staining the Door Panel

Use a high quality, heavily pigmented, oil-based stain (recommended).

Gel stains can also be used. Before starting, and occasionally throughout the project, stir the stain until the texture is creamy. We recommend before starting, you try staining a small inconspicuous area of the door panel to achieve the desired color. One coat of stain is required with the recommended (per manufacturer's instructions) dry time needed between sides. The stain should be applied in the following order working on one small section of the door panel at a time.



FINISHING ORDER

- #1 Panels and sticking (moulding profiles)
- #2 Vertical center areas (mullions)
- #3 Horizontal areas (rails)
- #4 Outside vertical areas (stiles)
- #5 Edge of door panel (includes both sides and top of panel)

STAINING PROCEDURE

1. Put on gloves and prepare your materials.
2. Stir stain thoroughly using smooth strokes, avoid creating bubbles and do not shake the stain container.
3. Working in the specified order and individual section, dip the foam brush into the stain then use the rim of the container to release any excess. Use the foam brush to apply the stain onto the section.

Using a cloth, rub the stain into the embossed woodgrain ensuring complete and even coverage. Stop between sections to tidy up the perimeter with a rag and mineral spirits or acetone. Clean edges will help define the individual components of the door. If preferred, the subtle color variation found in wood can be replicated by selective removal of the stain. Using a rag or cheese cloth, gently rub the surface removing very small amounts of stain. Apply varying levels of pressure and work in the direction of the grain. Excessive pressure will remove too much stain.

4. Once the door panel has been completely stained, check for any drips. While the stain is still wet, lightly brush the entire surface of the door with a china bristle brush. Use long strokes and work in the direction of the grain to even out color and achieve consistency.
5. Let the first stained surface dry, per the stain manufacturer's recommended drying time, before proceeding to the second side.
6. If you prefer a darker appearance, repeat staining steps one through five only after first coat is completely dry. Do not sand between staining coats.

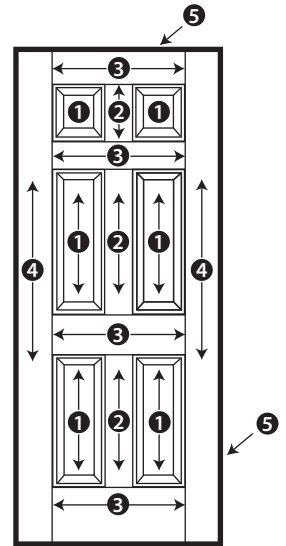

TOP-COAT APPLICATION

The top-coat or sealant for your door panel(s) is very important and required for weatherability. It protects the stained door from the elements and makes the door surface washable. Be sure the stain coating is completely dry and then apply a high-quality, UV stabilized, clear exterior polyurethane coating (satin or low gloss) - used for any normal exterior wood application.

Note: We recommend all 6 sides (front and back faces plus all four edges) be sealed to eliminate moisture absorption. The bottom of your door panel(s) may contain a factory installed weatherstrip (sweep) which is sealed prior to installation. Failure to observe this recommendation may void the warranty.

1. Stir top-coat thoroughly using smooth strokes, avoid creating bubbles and do not shake the top-coat container.
2. Do not overload the brush. Dip the end of the brush into the coating and gently slide the flat side of the brush against the edge of the container to remove the excess.
3. Apply with even gentle strokes. Press hard enough to flex the bristles just a little and then pull the brush gently along the door panel surface.
4. As you apply the sealant, pull the brush quickly along the area two or three times lightly to even out the brush strokes.
5. Allow the first coat to dry completely (follow manufacturer's recommendations) and apply at least one more coat using the same steps as above. A minimum of two coats is required for complete protection and the door should be resealed annually to ensure lasting protection of the finish.
6. After both sides of the door have been top-coated (twice) and are completely dry, remove the paper and tape from the glass and protected surfaces.
7. Clean the glass with window cleaner and remove any finishing materials from the glass with a safety razor.
8. Replace door panel back into frame.

MAINTENANCE

1. If the door panel surface is scratched after finishing, the damaged area can be lightly sanded using 400-grit sandpaper (do not over-sand the surface). Follow the staining and top-coat procedures.
2. Dirt and watermarks can build up on the surface of your finished door panel over time. Extend the life of the stain and top-coat by cleaning the door several times a year. Clean with warm soapy water, rinse and towel dry.
3. A minimum of two coats of top-coat are initially required for complete protection. The door system should be refinished every 1 to 7 years depending upon weather exposure.



HOW TO PAINT EXTERIOR DOOR PANELS AND FRAME COMPONENTS

NOTE: Painting instructions specifically refer to the door and sidelight panels.

Find a well-lit staining dust-free location, well ventilated and within the climate conditions recommended by the coating manufacturer. Recommended temperature should be between 50° - 90°F degrees fahrenheit.

You will need the following:

COATINGS AND ACCESSORIES:

- Mineral spirits or acetone
- Soapy water (mild detergent in warm water)
- Lint-free rags or cheese cloth (recommended)
- Paint
 - High-quality, oil-base or 100% acrylic water-based latex paint of desired color
 - Lacquer paints are not recommended
- High-quality, exterior grade, UV stabilized polyurethane sealant (satin or low gloss)

TOOLS:

- Hammer
- Pin punch
- Phillips screwdriver
- Pliers
- Safety glasses
- Rubber gloves
- 2-1/2" wide brush appropriate for type of paint (A natural bristle brush should be used with oil-based paint and a synthetic bristle brush should be used with latex paint.)
- Stir sticks
- Masking tape
- Safety razor blades
- 220-grit sandpaper
- Air-less sprayer (optional)

Please read and understand the entire painting procedures before attempting to finish the door. Be sure to follow the paint manufacturer's detailed application instructions on the product label.

A. How to start

Door panels can be painted either hanging in the opening or removed from the frame (recommended). Take care to protect removed doors from damage. Sidelights will need to be finished vertically. To remove the door panel from the frame, use a pin punch and hammer. Strike the hinge pin from the bottom until it pops up (for out-swing & self closing units - hinge leaf must be removed from the door panel). Drive the hinge pin as far as possible with the punch. Using a pair of pliers, grasp the hinge pin and, while twisting, pull the pin out. Remove all door panel hardware.

B. Preparing the door panel surface

IMPORTANT: For adequate paint adhesion the door surface must be free of dust, debris and other surface contaminants.

- Steel door panels should be wiped clean with a solvent such as acetone or mineral spirits. Allow the cleaning solvent to dry completely - until there is no residual odor. Once wiped clean, the door must be lightly sanded with a 220-grit sandpaper. After sanding, the door must be washed with a mild detergent in warm soapy water, rinsed and then dried.
- Fiberglass doors should be wiped clean with a solvent such as acetone or mineral spirits. Allow the cleaning solvent to dry completely - until there is no residual odor. Next, the door must be washed with a mild detergent in warm soapy water, rinsed and then dried.

Mask (tape) off all surfaces that will not be painted including all glass. Weatherstrips should be masked or removed temporarily to protect from finish

C. Painting the Door

Use exterior, high quality, oil-based or 100% acrylic water-based latex paint of desired color. High quality interior paint can be used on the interior surface of the door only. Lacquer paints are not recommended. Follow the manufacturer's instructions for paint application by using either a brush or a handheld sprayer.

PAINTING

Put on gloves, safety glasses, and prepare your materials. Before starting, and occasionally throughout the project, stir the paint using smooth strokes until the texture is creamy - avoid creating bubbles.

FINISHING WITH BRUSH APPLICATION

Dip the brush into the paint, then use the rim of the container to release any excess paint. Apply paint as evenly as possible while still wet. Brush strokes should follow the grain direction of the selected area.

Start working on the panels and sticking (moulding profiles), then the vertical center mullion, next the horizontal rails, then the vertical stiles, and finally, the outside edges (stiles and top rail, see figure 1 for details). Out-swing door panels or panel with adjustable surface mounted sweeps will need to have the sweep removed and the bottom rail painted.



FINISHING ORDER

For woodgrain textured door finishing with brush.

- #1 Panels and sticking (moulding profiles)
- #2 Vertical center areas (mullions)
- #3 Horizontal areas (rails)
- #4 Outside vertical areas (stiles)
- #5 Edge of door panel (includes both sides and top of panel)

FINISHING WITH SPRAY APPLICATOR

Follow the manufacturer's instructions for thinning the paint; (i.e. thin latex paint with water or oil-based with solvent for better atomization and spraying results). Strain paint before filling the spray pot. The door can be painted in horizontal (recommended) or vertical position; however, the paint should be applied in continuous strokes extending six inches past the edges of the door. This will ensure uniformity across the entire surface of the door. Multiple light coats are better than one heavy coat. Avoid runs as a result of over-spraying.

Note: We recommend all 6 sides (front and back faces plus all four edges) be sealed to eliminate moisture absorption. The bottom of your door panel(s) may contain a factory installed weatherstrip (sweep) which is sealed prior to installation. Failure to observe this recommendation may void the warranty.

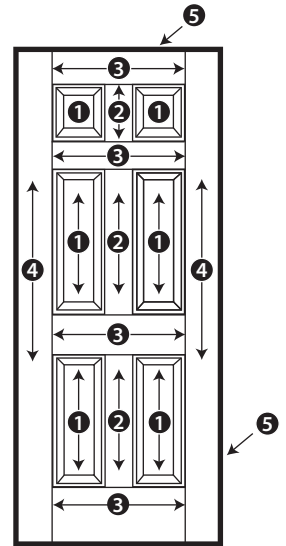

DRYING

IMPORTANT: Let the paint dry completely, following the manufacturer's recommended drying time before handling the painted surface or applying a second coat. If possible, allow the door to dry in a horizontal position to minimize paint runs. High humidity and/or low temperatures may extend your drying time.

Warning: Foam-filled door panels painted with dark colors or with attached storm doors, may become very hot to the touch in direct sunlight. Do not paint the weatherstrip and do not close door until paint is dry (see paint manufacturer's specifications on minimum drying time). To maintain product warranty: Paint the door, frame, header and brickmould within 45 days of installation.

MAINTENANCE

1. If the door panel surface is scratched after finishing, the damaged area can be lightly sanded using 400-grit sandpaper (do not over-sand the surface). Follow the finishing procedures on the inside of this brochure.
2. Dirt and watermarks can build up on the surface of your finished door panel over time. Extend the life of the paint by cleaning the door a few times a year. Clean with warm soapy water, rinse and towel dry.
3. Repainting every 1 to 7 years will be required, depending upon weather exposure.

CLEANING INSTRUCTIONS

GLASS: Remove any protective film and labels and clean the glass, using a soft, clean, grit-free cloth and mild soap or detergent. Be sure to remove all liquid by wiping dry or use a clean squeegee.

FACTORY FINISHED UNITS: A door panel that has been prefinished with stain or paint from the factory requires no additional finishing. Clean the surface with mild soap and water.

DO NOT use abrasives. DO NOT scrape or use tools that might damage the surface.

Notice: DO NOT use inappropriate solvents or brickwash or cleaning chemicals. If you do, permanent damage can result and the product failure, loss or damage would not be covered by the Limited Warranty.

CARE AND MAINTENANCE

Care and maintenance information is available by contacting your local Pella retailer. This information is also available at www.pella.com.

IMPORTANT NOTICE

Because all construction must anticipate some water infiltration, it is important that the wall system be designed and constructed to properly manage moisture. Pella Corporation is not responsible for claims or damages caused by anticipated and unanticipated water infiltration; deficiencies in building design, construction and maintenance; failure to install Pella products in accordance with Pella's installation instructions; or the use of Pella products in wall systems which do not allow for proper management of moisture within the wall systems. The determination of the suitability of all building components, including the use of Pella products, as well as the design and installation of flashing and sealing systems are the responsibility of the Buyer or User, the architect, contractor, installer, or other construction professional and are not the responsibility of Pella. Pella products should not be used in barrier wall systems which do not allow for proper management of moisture within the wall systems, such as barrier Exterior Insulation and Finish Systems (EIFS) (also known as synthetic stucco) or other non-water managed systems. Except in the states of California, New Mexico, Arizona, Nevada, Utah and Colorado, Pella makes no warranty of any kind on and assumes no responsibility for Pella windows and doors installed in barrier wall systems. In the states listed above, the installation of Pella Products in barrier wall or similar systems must be in accordance with Pella's installation instructions. Product modifications that are not approved by Pella Corporation will void the warranty.



OPTIONAL SILL PAN INSTRUCTIONS

- A. **Cut the sill pan** to the width of the rough opening plus 2".
Note: The 2" added onto the rough opening width is for a 1" bend on each end.
- B. **Make a 1" cut** in each fold at both end of the sill pan.
Note: These cuts will allow the edges of the sill pan to be bent.
Note: 4-5/8" wide for Out-Swing and In-Swing for 4-9/16" wall condition. For other wall conditions, measure wall depth and add 1/16".
- C. **Cut 1" off each end** of the interior sill pan lip.
- D. **Bend each end** of the center panel up.
- E. **Install the sill pan** by sliding into place until the exterior sill pan lip is flush with the exterior of the rough opening.
- F. **Apply sill flashing tape.** Cut a piece of flashing tape 2" longer than the opening width. Apply at the bottom of the opening, covering the exterior sill pan lip as shown.
Note: If applicable, apply spray adhesive to building felt prior to applying the flashing tape.
- G. **Cut a piece of flashing tape** to the width of the opening. Install tape to the sill pan and overlap the flashing tape from step 1F by 1". If needed add a second or third piece of flashing tape until the sill pan is covered to the interior sill pan lip.
Note: The purpose of this tape is to seal the sill screws when installing the door.
- H. **Cut two 9" pieces of flashing tape** with a 1" x 3" tab at the bottom, on opposite corners as shown.
- I. **Apply the tabbed 9" pieces of flashing tape.** The tape is applied so 2" will cover the inside of the rough opening and lap over the side flange of the sill pan. The 1" x 3" tab laps over the bottom flashing tape as shown.
- J. **Cut two 6" pieces of flashing tape** and apply to each side of the rough opening, overlapping the first piece by 1" and lapping the bottom over the side flange of the sill pan as shown.
- K. **Cut two pieces of flashing tape 1-1/2" x 6"** and apply to the bottom corners of the opening by beginning in the corner of the sill pan, with 3/4" of the tape applied to the sill pan and 3/4" of the tape applied to the side flange. The remainder of the tape is to be at a 45 degree angle onto the exterior.
- L. **Attach the aluminum sill support** or wood blocking to the exterior of the box plate to support the edge of the door sill. Place the sill support flush with the subfloor.

