

£1000 COMPO-5 DISK DRIVES TO BE WON!

# YOUR SPECTRUM

No.15 June 95p

Byte High, No Limit

**THE MEGAGAME**

## STAR TURN



*Be a Space Ace in Starion!*

**FOUR PIC PACKS COMPARED**

## PAINTING BY NUMBERS

*Our Pictures Tell the Story!*

**LIST'N'LEARN**

## FIRST FOR KNOWLEDGE

*Beat The Swot Squad!*

**YS MEGABASIC**

## SNAP, CRACKLE AND POP!

*100% Sound Proof Program!*

**THERMAL PRINTERS**

# HOT HEADS

*We Turn the Heat On!*

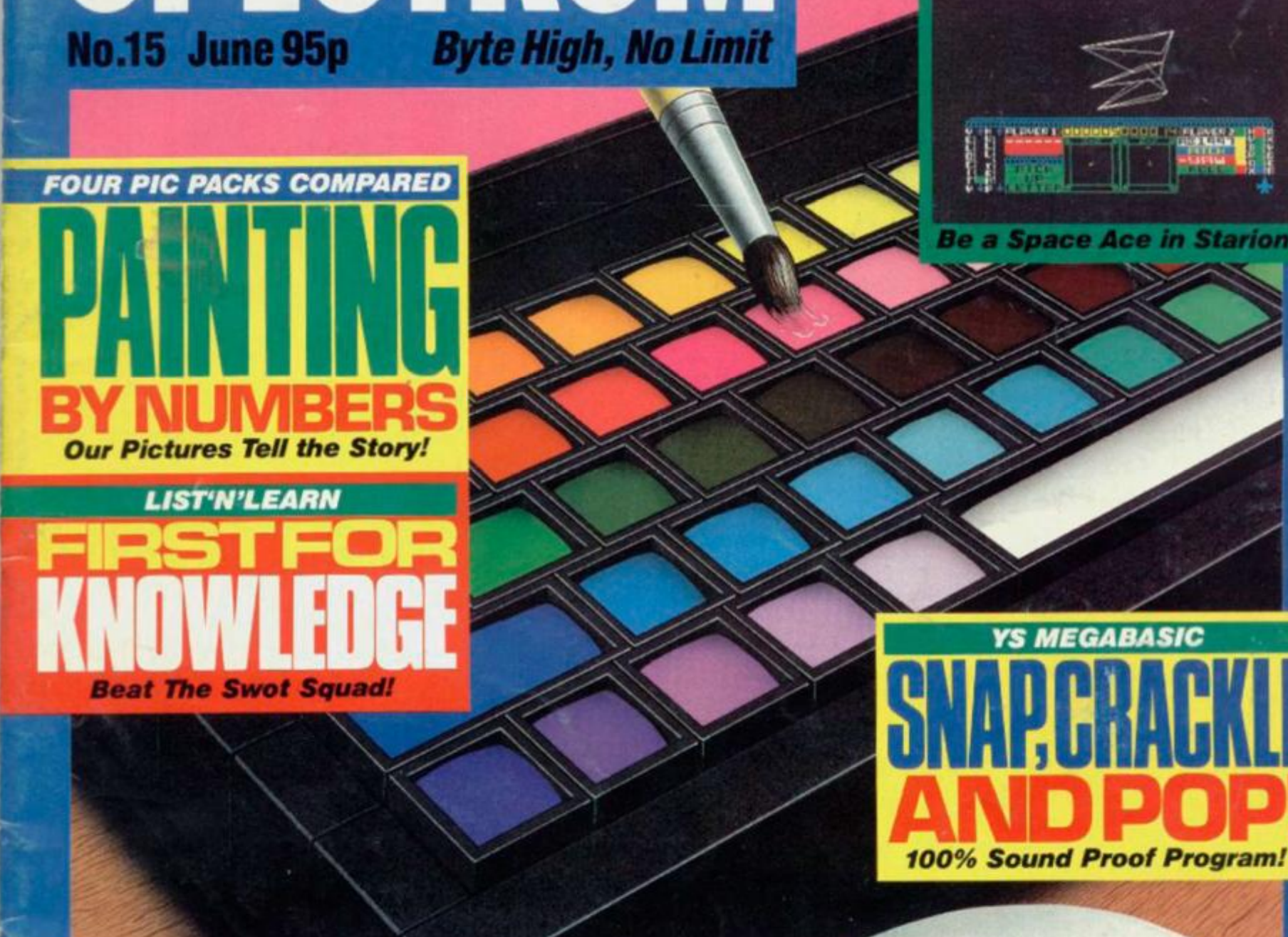
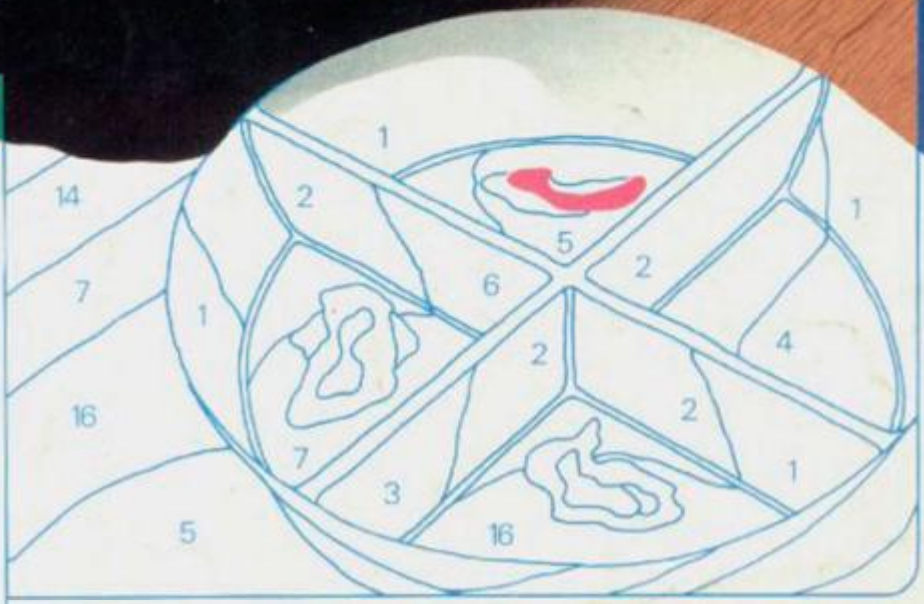



# THE SPECTRUM BASIC COMPILER

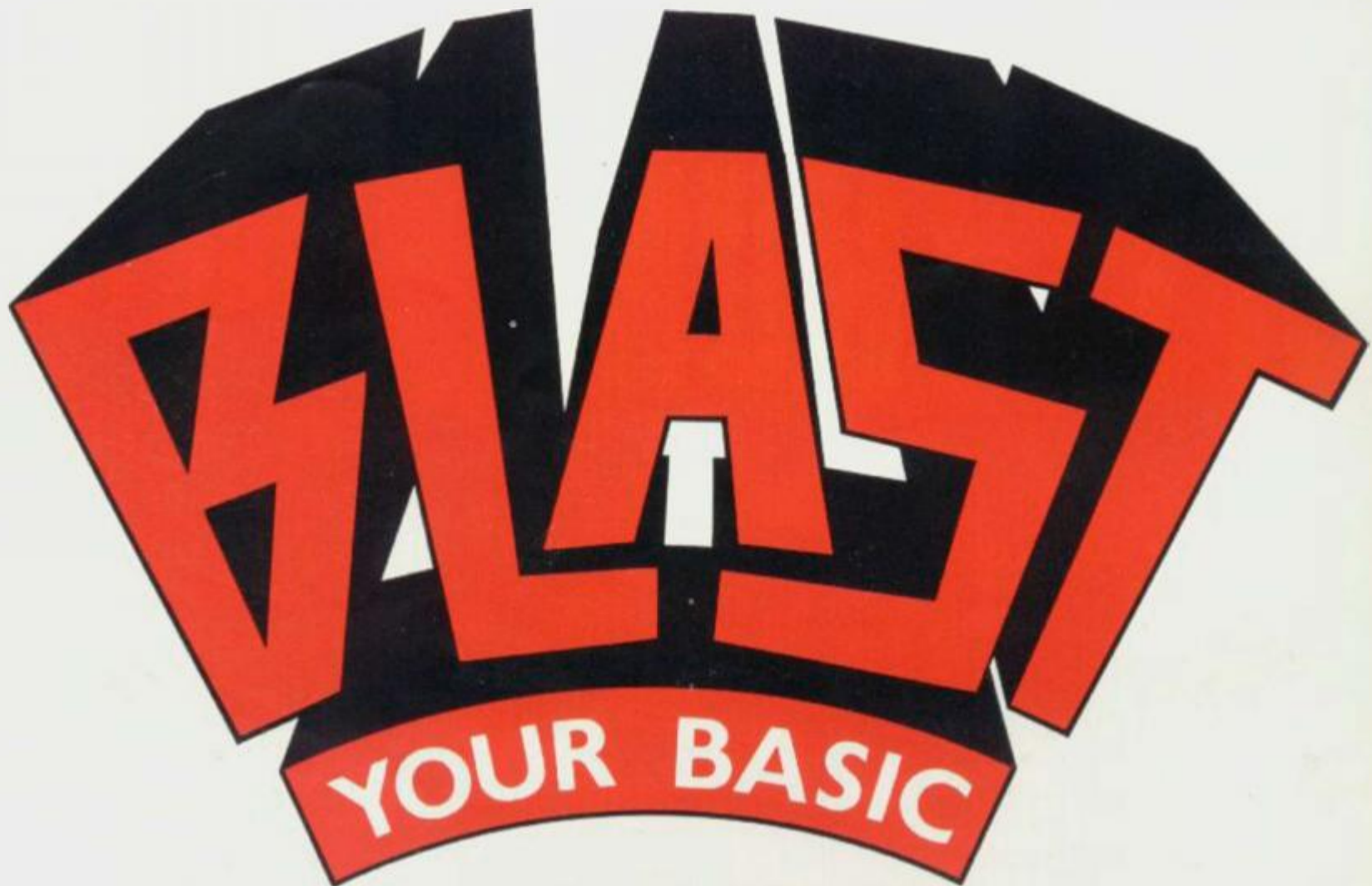

**UP TO 40 x SPEED INCREASE**

- ★ **BLAST!** is the first fully compatible OPTIMISING BASIC COMPILER for the Sinclair ZX Spectrum and Spectrum +.
- ★ **BLAST!** will compile ANY BASIC program, without alteration.
- ★ **BLAST!** will take your BASIC programs and transform them into super-efficient code running at up to forty times the speed of BASIC.
- ★ **BLAST!** can produce both native machine code and a compact p-code, for programs where space is at a premium.
- ★ When you have **BLASTED** your programs you are free to distribute or sell the results without any restriction.

## SIMPLICITY ITSELF

Using **BLAST!** couldn't be simpler. Just load it with your BASIC program and press "C" to compile. In a few seconds the compiled program is ready. Just type RUN and see your software run up to forty times faster.

## OPTIMISATION

**BLAST!** doesn't just compile your programs; it also applies a range of sophisticated optimisation techniques to enhance the performance of the compiled code. Any program can be compiled without alteration, but we think you will enjoy the wide range of extensions to BASIC built into **BLAST!** **BLAST!** features genuine integer variables, debugging facilities, program protection, and much more. It will operate in resident mode, or with tape or microdrive.

## TOOLKIT INCLUDED

**BLAST!** provides the complete BASIC programmer's package. As well as a sophisticated compiler **BLAST!** includes a comprehensive toolkit with a full range of features including renumber, single-step, search and replace, and block handling operations. Use it to test and develop your BASIC programs before compiling them with **BLAST!**

## STOP PRESS — OXFORD PASCAL

OXFORD PASCAL is now available for the SPECTRUM as well as the C64 and the BBC 'B'. To call us for details dial 100 and ask for FREEPHONE PASCAL.

Price/availability matrix		SPECTRUM	C64	BBC 'B'
BLAST BASIC		£24.95	N/A	N/A
OXFORD PASCAL	DISK	N/A	£49.95	£49.95
	CASSETTE	£24.95	£22.95	£39.95

All prices are inclusive of VAT  
Please add £2.00 for postage and packing.

Please rush me my copy of

My computer is SPECTRUM  BBC  64  Please supply CASSETTE  DISK

I enclose £..... including £2.00 p&p Please make cheques payable to OCSL Ltd.

Name: .....

Address: .....

Postcode: .....

Telephone: .....

0116 85



Oxford Computer Systems (Software) Ltd.  
Hensington Road, Woodstock, Oxford OX7 1JR, England  
Telephone (0993) 812700 Telex 83147 Ref. OCSL



# INSIDE YS

## MEGAGAME



36

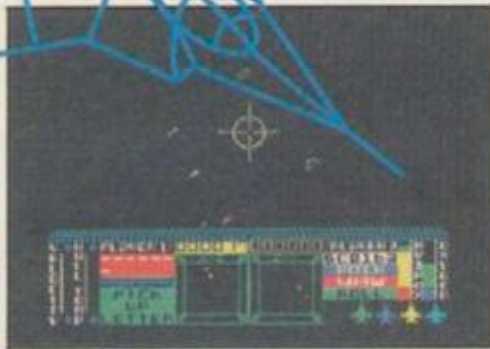

**Space Ace 3-2-1** Blast off! Join us for a space-age shoot 'em up. *Starion's* the star turn! *Ross Holman* and *Chris Wood*

## REVIEWS

28



**Painting by Numbers** Are you an artful bodger? Graphics software is the answer — count on it! *Peter Shaw* and *Penny Page*

42

**Hot Heads** Things are hotting up in the battle of the thermal printers. Stay cool and read on! *Peter Green*

51

**Joystick Jury** Our joystick jurors put all the new games through their paces. Read the results now! *Roger Willis*, *Ross Holman* and *Dave Nicholls*

## PROGRAMMING

20

**Pic 'n' Mix** Make a masterpiece by combining two screen pics. Go on, mix 'em up! *Chris Somerville*

33

**Interior Decorating** It's the complete DIY Guide to building and decorating in *Jet Set Willy*. *Dave Nicholls*

48

**Snap, Crackle & Pop** We're sounding off about *YS Megabasic* again! Now you can really be a big noise! *L.A. Privett*

## FREE LISTINGS

23



**Mastermind** We've made revision fun! It's just a question of mind over matter. *Chris Winterton*

61

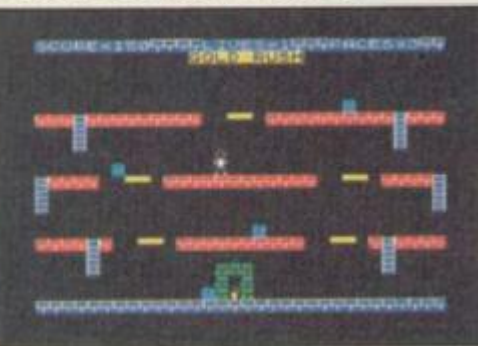

**Program Power** Four fantastic programs for hours of fun! Go on, power 'em up! *B. Herivel*, *M. Rapps*, *M. Rai*, *A. Leonard* and *M. Paknadel*.

## GAMES

**YS SOFT WARES** ..... 14  
Save £££s off selected software in our special readers' offer!

**YS CHARTS** ..... 15  
What's this? — the YS Top 10 and news of our great chart challenge. Check it out!

**SPECTRUM ADVENTURES** ..... 26  
Lost? Confused? We're here to help. Plus, the gruesome *Gremlins!*

**HACK FREE ZONE** ..... 72  
Hackers keep out! All new hints 'n' tips for gamers only! So, c'mon play the game!

## COMPETITION

**OPUS DISCOVERY COMPO** ..... 46  
This is the biggie! Five Opus Discovery disk drives must be won in our mighty mega compo. Turn those pages fast!

## REGULARS

**FRONTLINES** ..... 3  
If it's new, it's here. Plus *Hacking Away*, *From The Hip* and *Hard Facts* too!

**FORUM** ..... 17  
Bet you never knew there was so much in it! Write on!

**INPUT/OUTPUT** ..... 58  
Do a deal and make a friend, with a freebie *YS* classified ad!

**SUBSCRIPTIONS** ..... 14  
**BACK ISSUES** ..... 70

## SPECIAL OFFERS

**YS MEGABASIC** ..... 40  
Positively your last, never to be repeated, chance to pick up the miracle Basic at an all time low of £7.95!

**MODEM OFFER** ..... 47  
Tap your telephone with a Prism VTX 5000. Dial up a great deal now.

## CONTACT

**01-631 1433**

EDITORIAL ENQUIRIES  
Kevin Cox  
PUBLISHING ENQUIRIES  
Stephen England

**01-580 0504/  
631 1433**

ADVERTISEMENT  
ENQUIRIES  
David Baskerville

**01-636 2416**

**YS HELPLINE**

Peter Shaw  
(YS Helpline enquiries between 10am-1pm and 2-5pm, Wednesdays and Fridays only!)

Your Spectrum, Sportscene  
Specialist Press, 14 Rathbone  
Place, London W1P 1DE.

ABC

COVER BY MARK WATKINSON



# GEMINI

## for the 48K Spectrum

# BUMPER PACKS

### Business Bumper Pack

C.0415  
£24.95

The best in the business! Written by businessmen for businessmen, Gemini's board of Directors contains three Chartered Accountants, and their accounting software brilliantly maximises the potential of the 48K Spectrum for commercial use.

Containing a professional standard manual, the Bumper Pack is in fact a COMPLETE CASH BOOK ACCOUNTING SYSTEM replacing ALL manual records, and is ideal for the cash based business. You can transfer all receipts and expenditure records to the computer, together with Bank Account, Petty Cash records, and all VAT transactions. The system also supports 90 nominal accounts! Summaries are then prepared by the 48K, listing all the information which would normally take hours of tedious manual bookkeeping... in a fraction of the time. Gemini's Cash Book Accounting System is even used by Chartered Accountants for incomplete records.

Having prepared these summaries, and a Trial Balance, the software then allows you to add details of year end adjustments, such as Depreciation, Bad Debts, Creditors and Debtors, and prepares a full Balance Sheet and Profit & Loss Account. It even produces COMPARATIVE figures, such as budgets or previous years' results, alongside the current year's figures, together with notes to the accounts.

Written to the same specification as Gemini's widely acclaimed Accounting Systems for the BBC Micro and the Commodore 64, this BUMPER PACK for the Spectrum 48K represents quite remarkable value for money, and could easily save its cost in the first week of use! Business decisions can be made more quickly and profitably, based upon accurate, up to the minute, computer data, and vital management information is available from your 48K at the touch of a key.

Profit & Loss A/C and Balance Sheet

Trial Balance

VAT Records

Cash Book

Petty Cash

Bank Account

Suitable for Sole Traders, Partnerships and Limited Companies.

MICRODRIVE COMPATIBLE

Also available for the following machines:

Machine	Format	Code	Price
BBC Micro	Cassette	C.0405/6	£119.90
	40 track disk	C.0405/6/40	£119.90
	80 track disk	C.0405/6/80	£119.90
Commodore 64	Cassette	C.0818	£89.95
	Disk	D.0818	£99.95

### Home Software Bumper Pack

Contains the following programs, all cleverly and excitingly written to follow up to leisure software to truly exploit the Micro's potential for ALL the family (including Mother!).

C.0417 £24.95

**Database:** The Gemini Database Management System is a program designed to enable the user to store all types of information in similar format to a card indexing system. The program will ask you for the headings under which you wish to store the information on a 'card', i.e. for a record collection database these might be 'Artist', 'Song', 'Composer', etc., or for example in a database set up for a deep freezer, 'Use by date', 'Value', 'Type of food', 'Shelf', etc.

Having set up your fields, you may then add, delete or change information on the 'cards' under the headings you have elected. Gemini databases contain other important and useful utilities as well, e.g. alphabetical and numerical sorting, numeric calculations, finding records that meet specific requirements, line printer routines, browsing facilities, etc. For example a list of all recordings by a particular composer, calculate total value of freezer contents, etc.

**Mailist:** Gemini's Mailist program will enable you to keep a record of names and addresses and then print, examine, sort and find them, all with special selection techniques, containing our exclusive 'SEARCHKEY' system, giving you the option of creating your own dedicated coding system for each name on file. For example, on most mailing list systems, you are only given the standard heading such as name, street, town, country, postcode etc. With the Gemini searchkey system, you could find, say, all names on the file that are companies having a turnover in excess of '50,000' or all names that are subscribers who are behind in their subscriptions or all names that are eligible for a Christmas card this year!

A full and useful range of routines is included in the menu, and the program allows you to set up your own format for printing labels, i.e. the tab settings you require and spaces between labels, etc. Multiple copies can also be printed.

**Graph Plot:** Provides an easily assimilated visual representation of numerical data. For example monthly sales statistics comparing two year's results may be instantly converted into two side by side pie charts, histograms or graphs... for easier visual comparison and assimilation. It is particularly recommended where any kind of mathematical plotting facility is required.

### "Independent Press Comments"

"Remarkable software, friendly and well designed, a pleasure to use."  
— Gemini Cash Book, *The Scotsman* 12/8/83  
"Will enable business people with a moderate grasp of accounting principles to produce a set of figures that will satisfy both the bank manager and the Tax man."  
— Gemini Cash Book, *Micro User*, August 1983

**Home Accounts:** Designed as a complete Home Accounting package, this program allows the user to set up a budget for items of household expenditure and compare actual expenditure with budget. A running total of all surpluses and deficits is available both as digits, and in the form of a bar chart. A complete Bank account routine is included, together with suggested expenditure categories such as mortgage, rent, rates, telephone, gas, electricity, etc. However, these may be deleted or augmented without difficulty.

### Available from:

Larger branches of Boots and W.H. Smith and most good software dealers... or phone Gemini for prompt despatch quoting your Access, Visa, or American Express card number. Telephone (0395) 265165. Alternatively make your cheque or Postal Order payable to Gemini Marketing Ltd., and send to Gemini Marketing Ltd., 18a Littleham Road, Exmouth, Devon EX8 2QG.

Please send urgently

Prices stated in this brochure include VAT and Post and Packing (UK only).

Name

Address

Signature

Credit Card No. Access Visa American Express (delete)

Please send further information concerning:

YS



Will you be *Snowbound* this summer? Who's an April Fool then? Has Legend got a superiority *Komplex*? Is your thigh bone connected to your knee bone? Is *YS* doomed? Find the answers to these and other curious questions in ... Frontlines!

# FRONTLINES

## COUNT DOWN TO ... DUSTY BIN!

Ted Roger's TV programme, 3-2-1 made a brief and not very glorious appearance in the adventure game *Hampstead*. There you were in your dingy flat watching it on the telly — how low can a person sink? Now though it's about to be immortalised in its own game with the added attraction of not having to watch Ted Rogers!

There are thousands of promising prizes to win, but the game itself doesn't offer anything spectacular. Still, if you're after a holiday in Spain, a colour TV or lots of other luxury goodies, the procedure is pretty simple and could be worth a go!

The aim of the game is to gamble your point score according to the risks you want to take. Nothing too tricky there, so you may feel it's worth lashing out £9.99 and running up the points. At worst, you could end up with a Bendy Toy's Dusty Bin (*and I know where I'd put that! Ed*).

The game's only available by mail order so if you want more info before forking out the fivers give Paul Duffy a ring on 01-904 1735.

## SNOWBOUND?

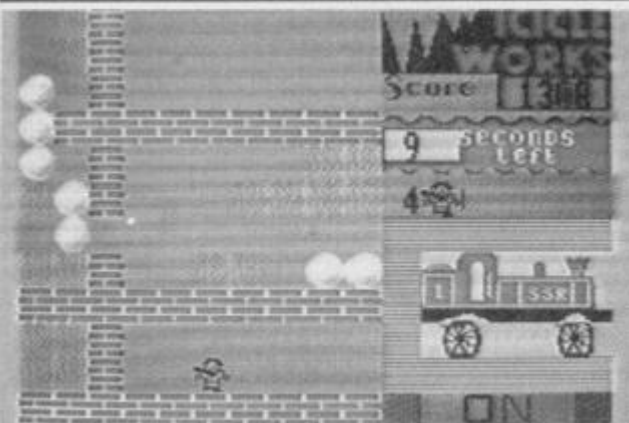

In the wake of *Boulder Dash* fever, Statesoft has come up with a little ditty called *Icicle Works* ... which has nothing to do with the rock group of the same name.

The idea of the game is to rush around the Arctic, collecting and

assembling the pieces of a toy.

Interested parties should gather round for a review in Joystick Jury next month. But for those who can't wait, give Statesoft a bell on (0438) 316561.



What's all this racquet? Jonah Barrington having beaten Rod Evans of New Generation Software at squash is about to beat him again. It's all in aid of the *Jonah Barrington Squash* simulation game that's soon to bounce onto the market.

So, now you can work up a sweat on the software squash court before trying the real thing. Could be a smash hit!

## SPECTRUM UK OK!

Compo results time again! This is the bit we all like — handing out the lovely lolly. Do you remember the Spectrum UK Competition back in issue 12? We asked you to put in order of importance the attributes you'd like to see on an imaginary Spectrum-based computer. The likelihood of something with even half the goodies we laid before you ever seeing the light of day is pretty remote. Still, it's always good fun to dream!

No-one came up with exactly the same list as our tame Sinclair spokesperson, so we picked as our winners the first out of the hat who came closest. The lucky prize winner will receive a voucher for £500 to be spent in any Spectrum UK store on Spectrum peripherals and software. And who is it, you cry. Step forward B J Rumbelow of Deal. You're about to acquire one of the largest Spectrum systems in the whole of the South-East!

But we're not finished yet — this really was a grand prize. There are still five more winners to be picked who'll receive similar vouchers for

£100. They are A D Stephenson of Worcester; M R Carre of Guernsey; J Lock of Llandaff North; Adrian Amell of Chichester and D P Minors of Pershore. Congratulations to all of you.

Oh, and what was the most important attribute of any new Spectrum based micro. Software compatibility was the first choice of the spokesperson and of the vast majority of our competition entries. It's pretty clear that none of you wants to start from scratch again, least of all B J Rumbleow — he or she would have an awful lot of software to replace!

## VIRGIN TERRITORY

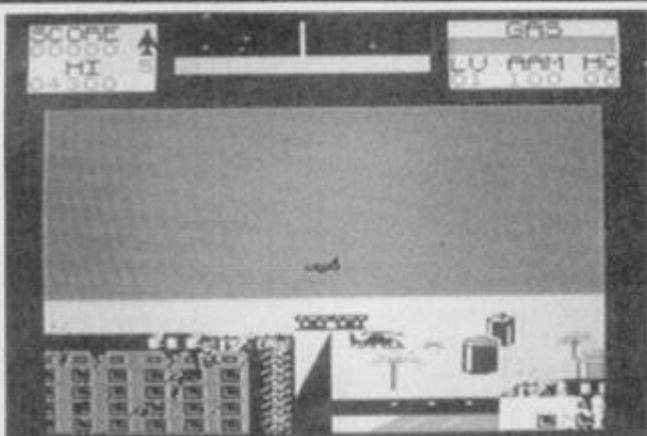

Prepare for take-off. Virgin, already famed for its cheapo Atlantic flights is moving into

jump jets as well. And you could be the pilot — if you get hold of a copy of *Falcon Patrol II* that's

just been released for the Speccy.

Single-handed you must defend a desert town as it comes under attack from wave after wave of deadly enemy helicopters. And they've a fearsome arsenal to use against you — missiles, flak batteries and radar jammers.

Virgin Games is convinced it'll be a runaway success, so if you want more info on departure times give them a buzz on 01-727 8070.



Is it the Dutch entry for the Eurovision Song contents in a nasty tussle over the microphone? Nope, it's Jools Holland presenting the lovely Louise Stamper of Ultimate with a Golden Joystick Award. Perhaps it was in the category for the Most Secretive House Ever! We were beginning to think they were just a figment of our imagination.



# FRONTLINES

## VIVA ESPANA

If you're thinking of spending your summer holidays under the sun in Spanish climes, how about getting your Speccy to help you with the lingo?

*The Spanish Tutor* from Kosmos has been around for a while, but at £8.95 it provides a good range of basic vocabulary and grammar. Trouble is it doesn't give you much chance to 'play' with the language. Still, if you're interested, give Kosmos a ring on (05255) 3942.

Much more fun is Silversoft's *Linkword*

*Spanish*, which uses the Gruneberg 'image to word' system; you're told, for instance, that the Spanish word for cat is 'gato' ... so imagine a cat eating a large piece of cake (gateau — geddit!). Priced at £12.95, you can find out more from Silver soft on 01-748 4125.

Soon to come is CDS's *Spanish Is Fun* which, priced at £7.95, promises to feature not only audio back-up but graphics as well! Give CDS an encouraging phone call on (0302) 744129 for more details. Buenas vacaciones!



YS brings you another scoop picture — Sir Clive's follow-up to the C5, the Sinclair aeroplane! It features a smart, functional design coupled with all the latest technology — wheels, for instance. What d'you mean, it's a bicycle? Oh, OK, the old biddy on the bike is actually *Super Gran*, 'cos Tynesoft is about to launch a game featuring the fearless granny. Just hope they fork out a bigger budget on the software than's been lavished on the hardware!

## ADRIAN MOLE'S SECRETS REVEALED

19th April 1985

I found out today that my secret diaries are being made into a computer game. Can't say I'm very pleased as I haven't even got a computer. Maybe I can persuade Dad to sell the dog and buy me a Spectrum. I phoned Pandora to tell her about my wonderful plan but she wasn't impressed. She said I'd be selling my soul for software next.

Anyway, once the game's out I'll be dead popular, then she'll be sorry. I only hope they



cut out the bits about my spots. I'd better phone Joe or Greg Lang at Mosaic Publishing Ltd on 01-226 4463 and find out.

## YS UNDER THREAT?

Deep in downtown Fratton, four enterprising pupils have started up a magazine called *CAS* (Commodore and Spectrum) *User*.

Present sales figures are peaking at 125 copies an issue which doesn't worry us too much yet — but from little acorns large computer companies have been known to sprout!

The problem is that *CAS* is very short of software for review and would appreciate any offerings. Any software they receive will be sold in aid of the Ethiopian Famine Appeal. So, readers and software houses, if you have any copies of spare software and want to donate it send it to: Mark Le-May, *CAS User* Editor, 45 Liverpool Road, Fratton, Portsmouth.

## BLOOD 'N' GUTS

New software house, Genesis has released *Body Works*, a series of programs that explore the human body in gory technicolor. And who should be behind this vivid and original study of our bodily capacities? None other than doctor and Arts buff, Jonathan Miller.

As author of *The Human Body* 'pop-up' book, Dr Miller has already demonstrated his penchant for the

# Paperdata

**The Hacker's Handbook**  
Longman Publishing/£5.95

**The Hacker's Handbook**  
Century Communications/£4.95

The recent interest in Data Communications (or Comms as it's come to be known) is growing rapidly. This is partly due to the coming of Prestel and Micronet, and partly because it's now possible to lay your hands on some relatively cheap modems. But why should you shell out for one? The modems may be quite cheap but it can still be expensive if you spend hours on the phone to some remote computer.

All very confusing for the beginner but help is at hand. It comes in the form of an excellent book from Longman Publishing called **The Hacker's Handbook**. The authors, Geof Wheelwright and Ian Scales, start you off from scratch with a short discussion on why Comms is important. They then take you through all the different stages of communicating, from buying a modem to a complete run-down on how to use Prestel and other remote database systems. The style's clear and easy to understand and all of the technical jargon is explained in footnotes and in a glossary of terms. This really is an excellent introduction to Comms with a lot of good, and up to the minute, information.

The second book is also, rather confusingly, called **The Hacker's Handbook**, this time from Century Communications. Its aims, however, are completely different. Hugo Cornwall (and there's a made-up name if ever I've heard one!) sets out to show you how to 'hack' — to gatecrash into computers when you haven't been invited or when you haven't paid the entrance fee. To boldly go where no-one wants you and where you shouldn't be! Remember the hoo-ha about the Prestel hacker who broke into Prince Philip's private account? So far, the results of hacking haven't been too disastrous — no nuclear red alerts like the one in the film *WarGames*, or none we know about. But you must remember that hacking amounts to stealing, whether of information or computer time. Indiscriminate hacking can also cause damage which costs a lot to put right if the hacker manages to do something really 'clever' by accident.

The book does contain some very useful information, especially the chapter on radio communications, but I can't really recommend it. Most computers holding 'secure' data are very well protected and I just can't see the point in spending a fortune on phone bills trying to get into them. You'd be better advised to use the money to gain legitimate access to the computer. At least that way you won't have the police knocking on your door in a dawn raid!

Dave Nicholls



unconventional approach to biology lessons. So it'll come as no surprise to YS readers that *Body Works* involves all sorts of games and simulations that allow you to romp around the digestive system, the brain or other interesting places. You can even simulate your own heart attack (*Who needs simulation? Ed*).

At £14.95, the package comes with a



wall-chart depicting all the lurid bodily details you'll need to know. Medical advice will be given by Jemima Blackwell in 01-240 9541.



# PERIPHERAL POWER

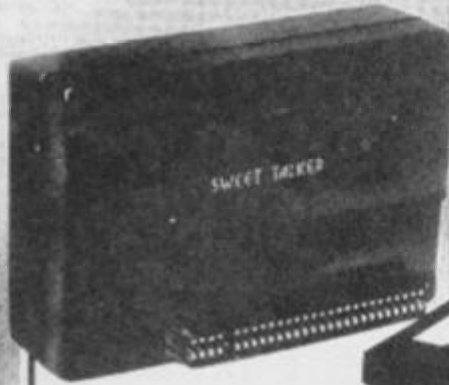

## CHEETAH "SWEET TALKER"

Based on an allophone system, program any word or phrase, providing unlimited speech. Now make your Spectrum talk. Compatible with Interface I & II and Spectrum +

£24.95

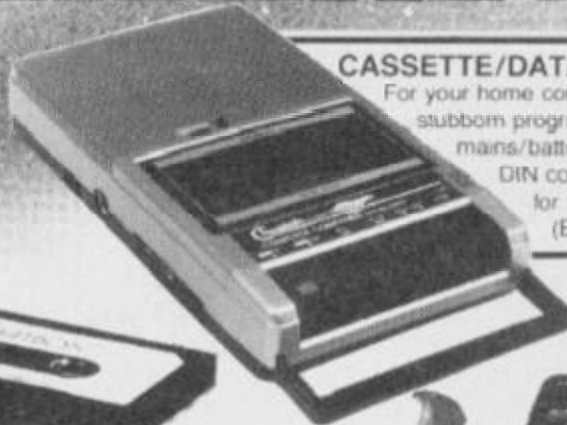

## CASSETTE/DATA RECORDER

For your home computer, will allow easy loading of even the most stubborn program. Features include single key record, mains/battery, accepts standard computer leads and 5 pin DIN connector. Also provides exceptional audio quality for fine listening. (Batteries not included)

£24.95

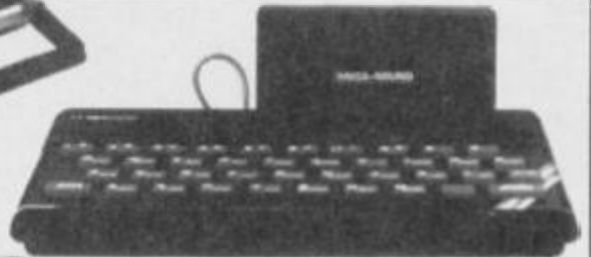

## MEGASOUND

For 48K Spectrum and ZX Spectrum + Achieve amazing sound capabilities that your Spectrum has been lacking. Just plugs into the user port at the rear of your computer and amplifies sound through your T.V.

£10.95



## 32K RAMPACK

Upgrade your 16K ZX Spectrum now! The Cheetah 32K Rampack simply plugs into the user port at the rear of your computer and increases the memory instantly to 48K

£39.95

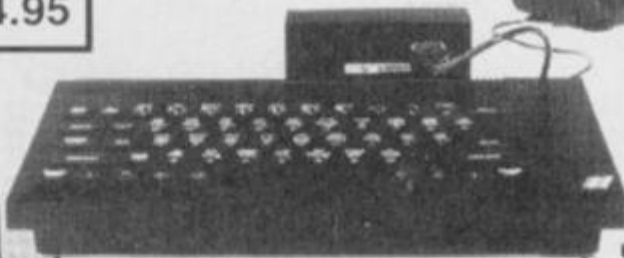

## SPECTRUM JOYSTICK INTERFACE

Simply plugs into the user port at the rear of the computer and accepts any Atari style joystick including Quickshot and Kempston. Comes without rear edge connector at

£11.50

or with connector which allows other peripherals to be stacked up at

£12.75

## 56 WAY EXTENSION CONNECTOR

Cheetah's 6" long extension cable enables Spectrum peripherals to be distanced from your computer

£7.95

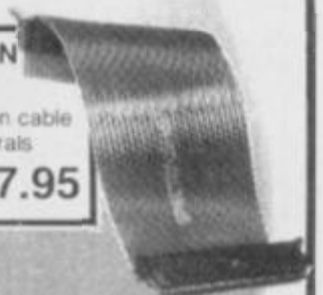

## R.A.T.

Conventional joysticks are dead! The Cheetah Remote Action Transmitter is the most sophisticated computer controller available! Infra red transmission - so there are no leads trailing across the living room. Touch control, extremely fast, can be used with Cheetah RAT/Kempston compatible software. Complete with receiver / interface.

£29.95

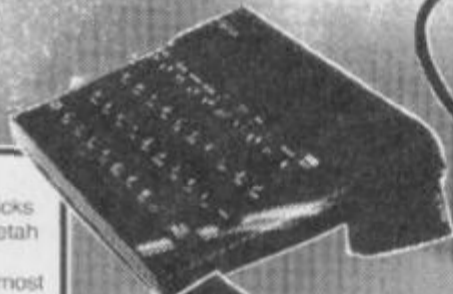

## HI-STAK FEET

These instantly applied stick on feet for your ZX B1, Spectrum, New Brain, VIC, TRS etc. tilt the computer and make your keys easier to see and more enjoyable to use, allowing smoother programming.

£2.99

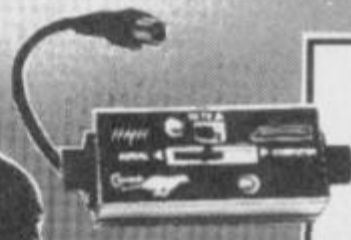

## AERIAL SPLITTER

Cheetah's neat splitter unit complete with self adhesive pad allows you to keep your T.V. and computer aerial leads plugged in without disturbing the picture

£2.25

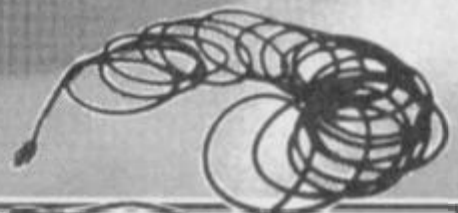

## EXTRA LONG AERIAL LEAD

Over 15' long. Our super lead will allow you to sit back away from your T.V. and enable you to play games in the comfort of your armchair.

£1.50

All Cheetah Peripherals have rear edge connectors for compatibility with all Sinclair accessories.

Prices include VAT, postage & packing. Delivery normally 14 days. Export orders at no extra cost. Dealer enquiries welcome.

Cheetah products available from branches of WHSMITH Rumbelows WOOLWORTH Spectrum dealers and all good computer stores.

**Cheetah**  
Marketing

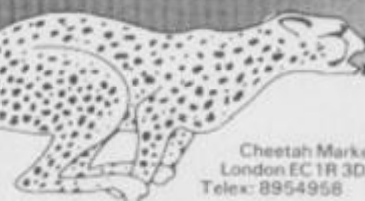

Cheetah Marketing Ltd, Dept YS, 24 Ray Street, London EC1R 3DJ, Tel: 01-833 4909 Telex: 8954956



# FRONTLINES

## RAINDROPS KEEP FALLING

They say it never rains but it pours! But we nearly drowned in the torrents of entries that came flooding down the YSMineshaft for our April Showers Compo.

Remember we asked you to find the 61st room in Miner Willy's mansion. Well, it seems that there's hardly a person in the kingdom who didn't find it.

Course, we did catch a couple of you — one of the 'wettest' entries came from **Steven Smithson** of Blackpool

who wrote in, "I claim the prize for telling you where the 61st room is . . . in Dave Nicholl's head." Sorry Steve — that's where the room came from but it's definitely in *JSW* now! And we'd have thought that coming from Blackpool you'd have been the first to find it. We'll let **Gareth Morgan** of Great Sankey rhyme you into the secret

*No problem finding  
April Showers,  
No searching round  
for hours and hours,*

*It's really quite  
within your reach,  
Climb up the rope  
above the beach!*

As **A L Hodson** of Northfield wrote, where else would you expect to find a shower but when you're on the beach!

And now the moment you've all been waiting for — who's the lucky person whose name came out of the Ed's hat first?

Well, our congratulations go to **J Blackler** of Lancaster — keep an eye out for a

large package of 10 Specky games in the very near future.

So, you all thought that April Showers was an April fool and then you found it wasn't (well, *most* of you found it wasn't). But hang on a sec, what have you just been doing with your time? We thought you'd got *JSW*itis months ago and here you are dusting down your copies and playing it all over again. Now don't you think that's just a little bit foolish?

## HACKING AWAY



**POKE fun into your games! Send your hacking hints to Andrew Pennell. Your Spectrum, 14 Rathbone Place, London W1P 1DE.**

Welcome back, hackers. Straight into a game which really is the pits, *Monty Mole*. My ol' friend **Chris Wood** has been tunnelling into it for you. The game loads as a 48K block

using up all the Specky's memory, so entering the POKES has to be done using a special loader. It's a long listing, so a short explanation's called for. First, it loads *Monty Mole* lower down in memory than it should be, leaving 1000 bytes in which to put a special loader. This gives *Monty* infinite lives, moves part of itself onto the screen, shifts what's left of the game back to its proper place, then runs it — phew, no wonder it's not short!

The data statements in the Basic program can be removed if you don't want a certain feature. Leave in the last line of 3 zeroes, though. **Chris** has also included a Game Abandon feature, using the G key. As this overwrites part of the scanning routine, the Basic asks which joystick option you want, and disposes of the other.

So, bash in the listing *Mole* fans and then save it to tape.

Load up the first part of *Monty Mole* — this will clear the screen — then stop the tape and reset your Spectrum. Next, load in the new loader

program, RUN it and if all is well you will get a STOP message so that you can test it before you save it to tape the first time. Then, enter CONTINUE and re-start the original tape without re-winding it. Don't worry about the messy screen as this will clear when it has finished loading. Cue Colonel Bogey and off you go.

From one mighty megahack to another. **Piers Pettman** has caught Horace fever, sending us not just infinite lives POKES but infinite POKES! There are no less than nine to help you combat the alien arachnids in *Horace and the Spiders*. Off we go then, remembering to add 0 after each of the POKES: no hills on the first screen — 25142, no spiders either — 28773, ropes are pulled in fast — 29626, jump onto next rope when you like — 29720, all spiders on the third level die instantly (*you don't believe in taking any chances, do you? Ed.*) — 30070, hills and more hills for the masochists amongst you — 25218, slow spiders on the third level — 29910, 'infinite' spiders on the third level — 30116, and if you're not too keen on the ropes being pulled on the third level try POKE 29626,52. If you still can't cope after that lot I suggest you forget the spiders and flush yourself down the plughole!

If you fancy a *Ski-ing* jaunt with Horace but have left your Green Cross Code book at home, try POKE 29009,0 which will clear the road of most of its traffic. You'll still have to keep an eye open for the ambulances.

**Andrew Dawson's** on the right lines with the POKES he's sent in for *Stop the Express*. First you'll have to load the program and de-encrypt it by MERGEing the first part

pausing the tape and typing CLEAR 25999 and finally LOAD "" CODE. Next, do POKE 48111,201: RANDOMIZE USR 48096 and you're free to poke around. For endless lives do POKE 34464,183:POKE 34926,183:POKE 35257,0, for unlimited time do POKE 35780,0:POKE 39549,0 and to change the starting carriage number PPOKE 40673,0: 40674,0:POKE 40674,0: POKE49261,N where N is number 21 carriage. Be careful on this last bit though, as some values will crash it — the game not the train! When you're ready for the off, use RANDOMIZE USR 32768 and it's full steam ahead!

A final quickie from Andrew — if you're having trouble with *Arcadia* from Imagine (*remember them? Ed.*) then POKE 25776,0 will make life a little easier.

I know how annoying it can be when you own a game that appears in this column and you just can't get the POKES to work. A lot of you had that problem with *Frank N Stein*. Well, it seems there were two versions of the game and **Dave Leander's** come to the rescue if you were unlucky last time — POKE 34124,0. It seems likely that *Ghostbuster's* got a twin too — any takers on that one?

**Kent Sorensen** from Sweden has ventured into Level 9's *Adventure Quest* to come up with a POKE that lets you remove any one problem from the game at a time. Simply press Break, then POKE 26388 with the room number you're stuck at, then CONTINUE. As he points out this is especially useful if you don't have the keys from location 18 to unchain the snowman. It's about time we had a few adventurous POKES, so keep 'em coming.

```

10 LET tot=0: FOR N=65000 TO 65101: READ A: LET
tot=tot+A: POKE N,A: NEXT n
15 IF tot<>10865 THEN PRINT AT 10,0:"Error in
Main Data": STOP
20 INPUT "KEMPSTON?":A$
30 IF CODE A$<>CODE "Y" AND CODE A$<>CODE "Y" T
HEN GO TO 50
40 POKE 65028,37: POKE 65029,127: POKE 65100,13
: POKE 65101,131
50 LET n=65102: LET b=1: LET c=1
60 READ a: IF a=0 THEN IF b=0 THEN IF c=0 THE
N GO TO 80
70 LET c=b: LET b=a: POKE n,a: LET n=n+1: GO TO
60
80 CLEAR 65535: STOP: RANDOMIZE USR 65000
90 DATA 62,113,221,33,24,60,17,0,192,55,205,86,
5,33,75,254,17,195,126,1,3,0,237,176,33,60,254,17
,7,127,1,15,0,237,176,33,78,254,126,95,35,126,254
100 DATA 0,40,7,87,35,126,18,35,24,241,17,0,64,3
3,43,254,1,18,0,237,176,195,0,64,49,232,95,17,0,0
,33,24,252,1,48,184,237,184,195,144,210,62,253,21
9,254,203,103
110 DATA 58,163,130,192,225,225,195,23,248,205,2
39,130
200 DATA 140,144,0
210 DATA 59,136,0,60,136,0,61,136,0
220 DATA 138,141,201
230 DATA 151,137,201
240 DATA 255,142,0,0,143,0,1,143,0
250 DATA 238,135,0,245,135,0,252,135,0
260 DATA 229,135,0,230,135,0,231,135,0
270 DATA 0,0,0

```



INCENTIVE

# CONFUZION

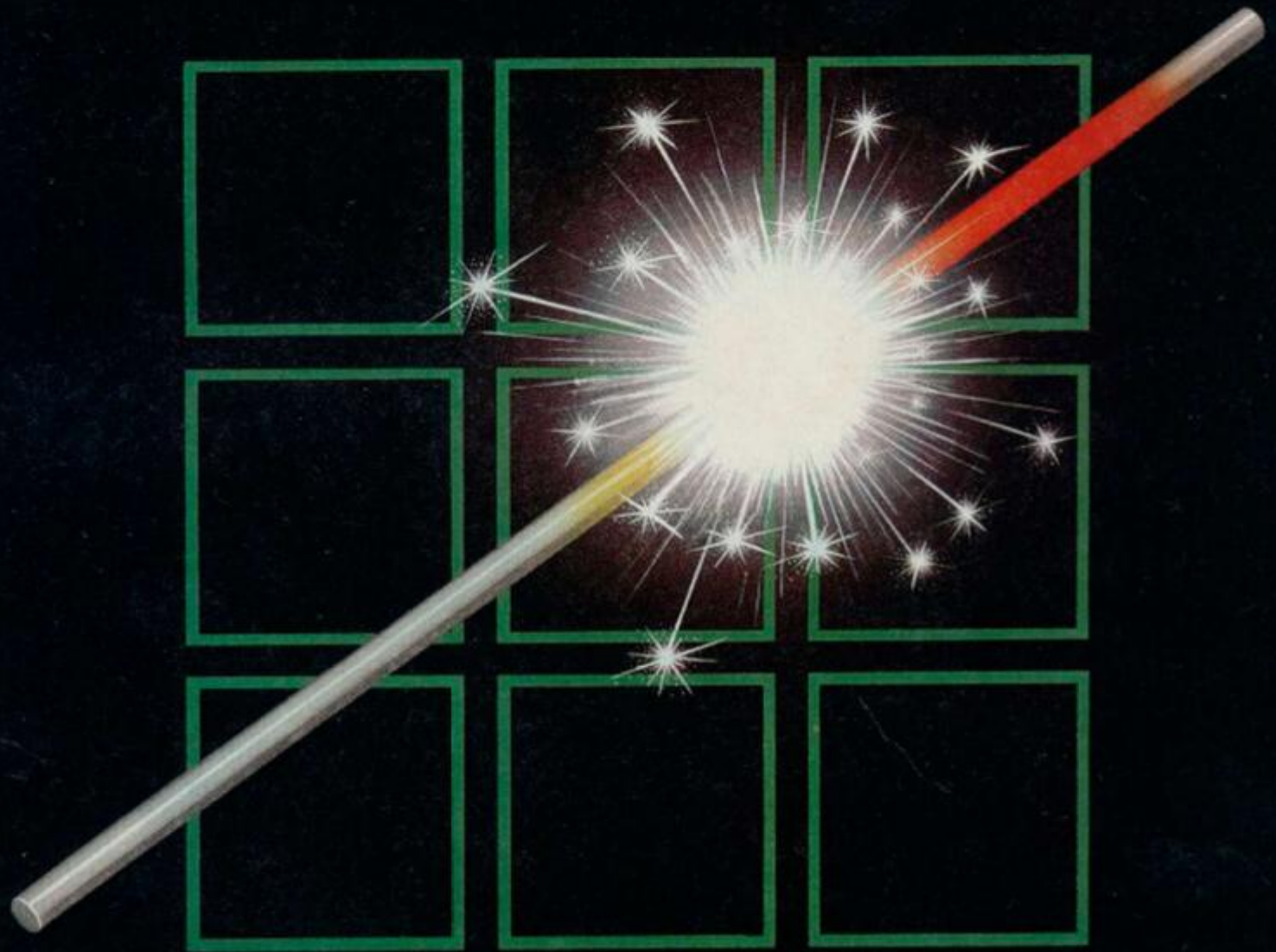

THE FUZION OF MIND AND MACHINE

★ SPECTRUM ★ SPECTRUM ★ SPECTRUM ★ SPECTRUM ★ SPECTRUM ★

Price £6.95 Trade and Credit Card orders: Telephone (0734) 591678

INCENTIVE, 54 London Street, Reading RG1 4SQ



# We'll take you bey

QUICKSHOT II AUTO RAPID-FIRE JOYSTICK

SPECTRUM INTERFACE









# 48K SINCLAIR ZX SPECTRUM



"ALIEN 8" recommended retail price £9.95 inc VAT  
Available from W.H.SMITHS, BOOTS, J.MENZIES, WOOLWORTHS  
and all good software retail outlets. Also available from  
ULTIMATE PLAY THE GAME, The Green, Ashby-de-la-Zouch, Leicestershire LE6 5JU  
(P&P included) Tel: 0530 411485





## HARD FACTS

How I'd like to bring you nothing but good news! Very often, though, when the hardware starts playing up you'll just have to join the JB Club. No, not hitting the whisky bottle, though you may feel like it, but putting the damaged goods in a Jiffy Bag and sending it off to the experts without delay.

That's certainly my advice to SA Tinkler of West Kirby. He's had a whole stack of problems since he bought a Stack Light Rifle. After using it for only a day, his Speccy developed shooting pains and now all he gets on the VDU is a lot of flashing squares and lines. It sounds to me as though you've blown up both your Speccy and the interface by fitting them together incorrectly. Best bet is to send the interface back to the manufacturer and the

From dodgy 'drives to suspect Speccies, Stephen Adams makes the connection — contact him at Hard Facts, Your Spectrum, 14 Rathbone Place, London W1P 1DE.

Spectrum to TV Services of Cambridge for a quick repair.

Robert Stockton of Wirral wrote to me with a problem that's a bit out of the ordinary. He's got an old ICL 22Si video console that contains a monitor and rather than let it go to waste he wants to interface it to his Speccy. Mmmmm. I'd say that could be extremely tricky, if not downright impossible, without a circuit diagram. Try writing to ICL at Bracknell to see if they'll cough up the necessary and then approach your local TV repairman to see if he'll do the rest.

All I can say to give you some idea, is that you can get a Commodore video signal from the Video and 0 volts connections at the back of your Spectrum. Is that any help?

Next comes a long tale of woe from Lewis Tyrell of St. Leonards-on-Sea. You can probably guess where the problem lies because we haven't mentioned them yet and it wouldn't be Hard Facts without something amiss with the Microdrives! Briefly stated, he keeps on getting a variety of

error messages. Just to take one example, typing CAT 1 just brings up a question mark and the syntax error message. And he knows the power's getting through because the LED light flashes on.

Well, it's still the connections between the Interface 1 and your Speccy. You'll usually find in such cases that the power functions OK because it's connected on either side of the keyway. However, the ROM's just not switching itself on when the extra commands are used which explains all the error messages you describe.

A lot of people also don't realise that the Interface 1 takes a minute or two to warm up before it's ready for proper action. So, before you enter any commands, just give it a while to get the old circulation going, especially if you're in a cold atmosphere.

Well, that's it for another month, but if you're having hassles on the hardware front, just drop me a line to Hard Facts, Your Spectrum, 14 Rathbone Place, London W1P 1DE.

## LOST IN SPACE?

Imagine drifting aimlessly in space, trying to find a stable orbit in a solar system you recognise. This is the 'new' plot that's been dreamed up by those great money-spenders at Legend for its new game, *Komplex*.

As yet we haven't been told how many hundreds of thousands of pounds it's cost to put this one together, but you can always ask the company on 01-524 8324/5.

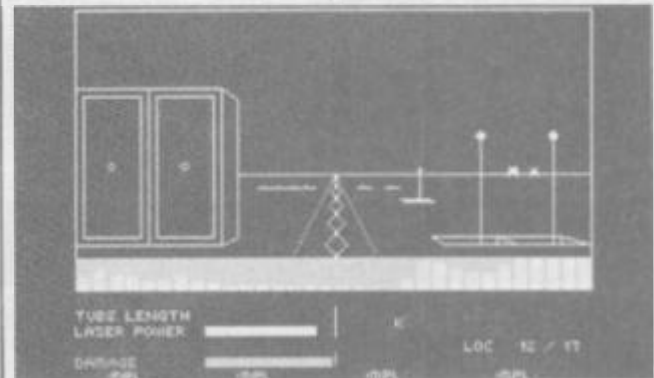

# FRONTLINES

## FROM THE H/P



Are you hopeless with headerless files? Me too. I've been receiving a fair number of calls asking how to load and save headerless files, so I thought it was about time I got out of my comfy chair and found out.

After a quick consultation with our ol' friend Tony Samuels I finally got it sussed. Firstly, if you want to save a headerless file in machine code, load the A register with 255. This is to signify that you're saving a block of data and not a header. Then load IX with the start location of the block of code you intend to save. Still with us? Good. Now

load DE with the number of bytes that you want to save, then CALL 04C2h, and RET brings you back to Basic. Complicated, innit?

Here's an example if you're feeling a bit overwhelmed. Say you want to save a screen pic without a header, then your assembler listing would look something like this:

```
LDA,255
LD DE,6912d
LD IX,16384d
CALL 04C2h
RET
```

Now to re-load the screen pic you've just saved, the code reads as follows:

```
SCF
LD A,255d
LD IX,16384d
LD DE,6192d
CALL 0556h
RET
```

The parameters here are the same as when you're loading, except for the SCF command which sets the carry flag. If we didn't set the carry flag, the program would just verify instead of loading. If you want to do a headerless verify, just swop the SCF command for an AND A instruction. Right, I'm going straight back to the armchair after that lot.

Someone who wants to retain a touch of mystery called in anonymously to ask how to

round up figures to two decimal places. This is one I can figure out for myself — just put your variable (in this case A) through this equation after every evaluation:

$$\text{LET A}=\text{INT (A*100)/100}$$

That'll move you two places to the left, strip off anything on the right-hand side of the decimal point and then move the variable two places back to the left.

A S Hampson of Derby gave me a bout of verbal violence about the Big Deal! program in our April issue. He hadn't a clue what we meant by 'clear space above 8000hex'. Sorry about that — even we nod off at times (*Wakey, wakey, Peter! Ed*). What we really meant was for you to perform the command CLEAR (address) which is 8000hex in this case.

Not being the most practical of people, I'm not really the person to offer advice on the next problem. Giles Harpenden of Ashford, Kent wants to 'up-grade' his Speccy into one of those nasty QL-clones! What's worrying him is the prospect of wielding the soldering iron, so should he spend the extra tenner and send it off. My advice is solder on — take the money and open the box! All that's needed is a couple of dabs of hot solder to

fix the resistor. If you want some practice perhaps you should have a test run on one of those cheapo electronic project kits. If you can get one of those up and running, you'll have no trouble with a dinky little resistor. But then as I say, I'm not really the person to ask — I love my Speccy just the way it is!

Finally, here's a chance for all of you who find our usual compos too hard. All you have to do to win an 'I Beat Pete' certificate is to baffle me with a *sensible* question about the Speccy and its related soft and hardware. Now that can't be too difficult, can it? To enter the Troubleshootin' Pete Question Challenge, all you have to do is send your question to me on a postcard along with your name and address. The address is The Troubleshootin' Pete Question Challenge, *Your Spectrum*, 14 Rathbone Place, London W1P 1DE. We'll print the best ones to beat me (*and could he do with a good beating! Ed*)

Still, if you've got a problem that requires instant action, you can always catch me on the lines!

**Troubleshootin' Pete**  
*Pete's phone lines are open from 10am-1pm and 2pm-5pm on Wednesdays and Fridays. Ring him on 01-636 2416.*



### Are you taking your Spectrum seriously?



**£69.95**  
plus  
£2.00 p&p

The Transform Keyboard transforms your Spectrum into a fully operational professional machine.

- Will incorporate micro-drive interface and power supply
- 60 keys including fullsize space bar
- Large ENTER key
- Full stop, comma, semi-colon, colon, single delete and edit keys
- On/off switch with LED
- Easy installation – no soldering required
- Black anodised case
- Now with 3 colour printed key tops
- EMODE key

*"Its price of £69.95 reflects the kind of use to which it will be put but it is certainly the top keyboard at the moment."*

SINCLAIR USER JUNE 1984

### Business Software

#### Business Bank Account £10.75

This program will enable you to enter debits under 17 different subheadings. Statements include totals of all subheadings.

#### Sales Day Book £10.75

For all your invoices, this program will enable you to prepare statements of outstanding invoices. Program will also calculate VAT.

#### Purchase Day Book £10.75

Keeps a complete record of all your purchases under 17 different subheadings. This program also calculates VAT.

#### Business Pack £25.00

Including all the above programs.

#### Stock Control £10.75

Handles 900 lines, including details of supplier. Program has full search facilities enabling you to search and update all lines from one supplier.

#### Invoicing £15.00

This program will print out invoices, calculates discounts and VAT. The program will calculate totals from unit prices. Up to 50 accounts with 250 outstanding invoices.

#### Word Processing by Tasman £13.90

Tasword Two is a powerful word processing program that will perform all the functions available on large processors. The program will give you 64 characters per line on screen.

#### Masterfile by Campbell Systems £15.00

This is one of the best database programs available for the ZX Spectrum. This program has many uses in a small business.

#### Dian by Campbell Systems £7.95

Use your Spectrum to sell your products. Dian will display messages in up to 11 different typefaces. Will scroll text in any direction.

#### 64 Column Generator by Tasman £5.50

You can use this program within your other programs to display 64 columns on screen.

#### Payroll by Byte One £19.95

This payroll program will handle up to 40 employees and will calculate NIC, PAYE, super-annuation and many other deductions. This is a very user friendly program and extremely good value.

### NEW

#### Sales/Purchase Ledger Invoicing £25.00

This program is for use on micro-drive only. The program will print an invoice using a built-in price list and post the invoice to your customer's account. Will also print price lists, statements, labels etc.

#### Tasmerge £10.95

Allows you to transfer data from Masterfile into Tasword enabling you to use Tasword for mail merge. The program allows you to specify line and column of each field. For use on micro-drive only.

#### Superfile £14.95

This is a new database program that stores pages of text 64 columns x 22 rows. The program includes word processing and full search facilities.

#### Omnicalc 2 £14.95

This is the long-awaited micro-drive version of omnicalc complete with histograms and many other features.

#### Projector 1 £13.90

Business graphics program that will help you present your cashflow, sales expenditure in many different ways including pie line, and histogram charts.

#### Tasprint £9.90

Use this program with Tasword Two to produce 5 different fonts on a dot matrix printer.

#### MF-Print £6.95

Enables you to set a print format for your full-size printer within masterfile. Supplied complete with masterfile for £19.95.

#### Trans Express £9.95

Micro-drive utility program which will enable you to backup all your micro-drive cartridges.

#### Now in stock

Blank micro-drive cartridges ..... £4.95

Continuous paper ..... £12.99

Printer ribbons from ..... £3.50

### QL

Centronics Interface ..... £39.95

QL Dust Cover ..... £5.00

Transform can supply a wide range of printers, monitors, and leads for the QL. For further details send S.A.E.

### Monitors

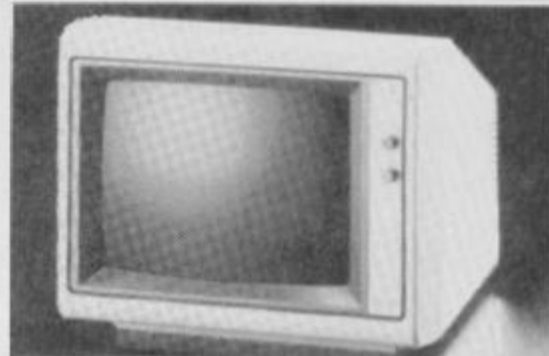

It is possible to connect your Spectrum to both Black/Green and composite Video monitors using high resolution monitors are particularly useful with programs like Tasword that use 64 columns. We supply complete instructions on how to connect monitors to both Issue Two and Issue Three Spectrums. These monitors can also be connected to your QL.

Phillips black and green ..... £75.00

Kaga/Taxan black and green ..... £99.95

Sanyo Med res for QL ..... £273.60

### Printers

All the software we supply runs on full-size printers (unless you are using interface 1) you will require an interface to connect your Spectrum to a printer, the interface we supply uses the graphics characters to set printer codes as in Tasword and prints a double size screen dump.

Centronics/RS232 Interface ..... £45.00

#### Dot matrix printers

Brother HR5 ..... £132.00

Brother M1009 ..... £163.00

Star Gemini 10x ..... £199.00

Epson RX80 FT ..... £229.00

Epson FX80 ..... £324.00

#### Daisywheel printers

Smith-Corona TP I ..... £189.00

Silver Reed EXP500 ..... £284.00

Brother HR15 ..... £349.44

Please add £5.00 delivery plus VAT to the price of printers and monitors. All software prices include VAT, post and packing.



TRANSFORM LTD. (Dept. YS)

01-658-6350

24 West Oak, Beckenham, Kent BR3 2EZ

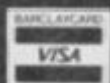



# FREE SOFTWARE FOR LIFE!



**New Gold Star life membership of The Software Library is your key to a vast treasure trove of tapes costing up to £18 each. They are yours whenever you want them, three at a time... and a full week's rental won't ever cost you a penny in hire fees!**

Only the original Software Library has the resources to make such an amazing offer—free software for life! Our ten megabyte computer ensures fast service; our illustrated, descriptive catalogue makes it fun to choose from over 80 top arcade games, 124 Adventures, simulations and other games, and over 120 great utilities and serious applications; 65% are for the Spectrum, the rest divided between Commodore 64 and ZX81. New releases are constantly being added. Joining this money-saving scheme should cost you £24; as an introductory offer, you can join this month at half price—£12. From then on, you can take away three tapes from our shop whenever you wish; or if you order by post, all we ask is 30p post/packing per tape. The rental is perfectly free in either case.

What's more, you can sell your surplus software to other members (we have over 5,000!) and recoup the cost of membership in no time at all. We offer huge discounts on peripherals and tapes... and so much more. Phone us now on 0730 892732, quoting your Access number, or return the coupon without delay!

**GUARANTEED to save you more than any other software library scheme!**

**SOFTWARE LIBRARY** FARNHAM ROAD, LISS, HANTS GU33 6JU

Please enrol me at the introductory offer, and send my membership pack by return.

NAME..... I enclose cheque/P.O. for £

ADDRESS.....

**THE ORIGINAL SOFTWARE LIBRARY!**

OVERSEAS: join here for £18, or join one of our foreign branches: Postfach 7900, 4800 Bielefeld, W. Germany; Jacobijnstraat 75, B-2400 Mels, Belgium (also covers Holland); 122 S Circular Road, Dublin 8; Pader Lykkevej 33, 2300 Copenhagen S; Box 1769, Manzini, Swaziland. France & Italy soon. Branch terms vary. All software listed with supplier's permission. VS

**New**

## TEAM UP WITH FLOYD!

# FLOYD 40

**BUILT IN INTELLIGENCE FOR YOUR SPECTRUM PRINTER**

**SPECIAL OFFER**

**£69.95**



- Features**
- Clear easy to read print
  - No split words
  - Indented printing
  - 32 or 40 characters-software selectable
  - Firmware program — no loading from tape
  - Comprehensive instruction manual supplied
  - Interface 1 & 2 compatible
  - Spectrum + compatible
  - No interface required

The printer comes in a slim plastic case which will compliment your spectrum. It connects with the spectrum via a 56-way ribbon cable and all connections are brought through to the back of the printer. The printer has two switches — one for paper feed and one for on/off line. A roll of paper is included in the price.

1. GRAPHICS MODE
- FULL GRAPHICS CAPABILITY—NORMAL 32 CHARACTERS PER LINE.
2. ADJUST MODE
- THIS IS A HIGH QUALITY THERMAL PRINTER FOR THE SINCLAIR SPECTRUM. IT HAS THREE MODES OF OPERATION:
- THE GRAPHICS MODE
  - THE ADJUST MODE
  - THE LIST MODE
- AND THREE SPECIAL FEATURES:
- DOUBLE HEIGHT
  - DOUBLE WIDTH
  - INVERTED PRINTING
- IN THE ADJUST MODE THE PRINTING IS SUCH THAT NO SPLIT WORDS OCCUR, AND PRINTING IS DONE WITH UP TO 40 CHARACTERS PER LINE.
- IT IS POSSIBLE TO MIX THE DOUBLE HEIGHT AND DOUBLE WIDTH
- INVERTED PRINTING IS ALSO POSSIBLE!**
3. LIST MODE
- THE LIST MODE ALLOWS BASIC PROGRAMS TO BE MORE EASILY READ BY INDENTING THE PROGRAM STATEMENTS FROM THE CORRESPONDING LINE NUMBERS.
- ```

340 REM THIS IS AN EXAMPLE OF THE LIST
MODE WHICH INDENTS STATEMENTS AND
PREVENTS WORDS BEING SPLIT
345 DATA 10,38,42,22,65,2,43,54,67,75,8
9,78
350 LPRINT "
360 LLIST
370 LPRINT "

```

# SPECTRUM+ MAGIC



Tim Hartnell, the world's best-selling author of books on the Sinclair computers, has turned his attention to the Spectrum+ to produce three major works.

**SPECTRUM+ LOGO.** Just type this program in, and you'll have LOGO graphics running instantly on your Spectrum+ or Spectrum. No need to buy the language. Comes with complete tutorial on LOGO graphics. Book contains full program and tutorial, £2.99 (ISBN 0 907563 65 2).

**EXPLORING ARTIFICIAL INTELLIGENCE ON YOUR SPECTRUM+.** Study the fascinating world of Artificial Intelligence, as you demonstrate many of its exciting discoveries with the eight programs in this book. The Computer Bookshelf section of *The Bookseller* called this work "the best book on AI I have ever seen". £6.95 (ISBN 0 947695 05 2)

**ASTOUNDING ARCADE GAMES ON YOUR SPECTRUM+.** Four great arcade games in this special 32-page edition of Kwik-Bytes. Just £1.25 (ISBN 0 907563 70 8)

Available from good book and computer shops, or (post free) from:

**Interface Publications Ltd., Dept. QTYS,**  
9/11 Kensington High Street,  
London W8 5NP

(UK Trade: WHS Distributors)



# Interface

**£69.95 (+ £4.95 P&P)**

TO: FLOYD, 153 MERRION ROAD, DUBLIN 4, IRELAND

I enclose cheque/p.o. for £                      made out to FLOYD —

.....printers @ £74.90 EACH (incl p&p) =

.....boxes of 10 rolls of paper @ £15.00 =

.....rolls of paper @ £2.50 each =

TOTAL =



# SUBSCRIBE TODAY... AND SEE WHAT YOU'RE MISSING

Who cares if you're heading for a spot of trouble as long as you can take a few copies of **Your Spectrum** along with you! Make sure you've got yours at the ready — by sending off the coupon below to Specky Subs, **Your Spectrum**, 14 Rathbone Place, London W1P 1DE.



## SUBSCRIPTIONS: PRIORITY ORDER FORM

**YOUR  
SPECTRUM**

I would like to subscribe to **Your Spectrum**. Please start my subscription from the..... issue.

Please tick appropriate boxes:

- One year £12 UK and Eire
- One year £15 Europe
- One year £25 Rest of the world (inc. Mars)

I enclose my cheque/postal order payable to SportsScene Specialist Press Ltd for £.....

Please charge my Access/Visa/American Express/Mastercharge card number .....  
(Delete where not applicable)

Signature .....  
(Credit card orders cannot be accepted without a signature)

Name .....

Address .....

Postcode ..... Phone No. ....

Send the completed form with payment or credit card number to: **Your Spectrum** Subs, 14 Rathbone Place, London W1P 1DE. If you don't want to cut up your magazine, use a photocopy of this coupon.

## Save £££s off selected software titles in this exclusive special offer for all YS readers. Go for it ...

The price of commercial games software is always on the increase ... unless you take advantage of our special readers offer and save yourself a fortune. Each month, we'll be offering you a long list of 'pocket-money specials' that'll include many of the latest and greatest games around — and you can order as many or as few as you want!

# YS SOFTWARES!

|                                                                                | R.R.P. | OUR PRICE |
|--------------------------------------------------------------------------------|--------|-----------|
| <input type="checkbox"/> <b>Underwilde</b><br>Ultimate (002)                   | £9.95  | £8.95     |
| <input type="checkbox"/> <b>Daley Thompson's Decathlon</b><br>Ocean (001)      | £6.90  | £5.90     |
| <input type="checkbox"/> <b>Match Day</b><br>Ocean (004)                       | £7.95  | £6.95     |
| <input type="checkbox"/> <b>Knightlore</b><br>Ultimate (005)                   | £9.95  | £8.95     |
| <input type="checkbox"/> <b>Monty Mole</b><br>Gremlin Graphics (008)           | £6.95  | £5.95     |
| <input type="checkbox"/> <b>Jet Set Willy</b><br>Software Projects (006)       | £5.95  | £4.95     |
| <input type="checkbox"/> <b>Chequered Flag</b><br>Psion (016)                  | £5.95  | £4.95     |
| <input type="checkbox"/> <b>Sabrewulf</b><br>Ultimate (003)                    | £9.95  | £8.95     |
| <input type="checkbox"/> <b>Atic Atac</b><br>Ultimate (013)                    | £5.50  | £4.50     |
| <input type="checkbox"/> <b>Ghostbusters</b><br>Activision (010)               | £9.99  | £8.99     |
| <input type="checkbox"/> <b>Softaid</b> (£1 goes to charity!)<br>Various (021) | £4.99  | £5.99     |
| <input type="checkbox"/> <b>Alien 8</b><br>Ultimate (022)                      | £9.95  | £8.95     |
| <input type="checkbox"/> <b>Everyone's a Wally</b><br>Mikro-Gen (023)          | £9.95  | £8.95     |
| <input type="checkbox"/> <b>Skool Daze</b><br>Microsphere (009)                | £5.95  | £4.95     |
| <input type="checkbox"/> <b>Raid Over Moscow</b><br>US Gold (024)              | £8.95  | £7.95     |
| <input type="checkbox"/> <b>Technician Ted</b><br>Hewson Consultants (025)     | £7.95  | £6.95     |
| <input type="checkbox"/> <b>Cyclone</b><br>Vortex (011)                        | £6.95  | £5.95     |
| <input type="checkbox"/> <b>Hunchback II</b><br>Ocean (026)                    | £6.90  | £5.90     |
| <input type="checkbox"/> <b>Booty</b><br>Firebird (014)                        | £2.50  | £1.50     |
| <input type="checkbox"/> <b>Project Future</b><br>Micromania (027)             | £6.95  | £5.95     |

At these ridiculous prices, how could I resist this exclusive YS offer? I've ticked the games I want to order and enclosed a cheque for £..... made out to SportsScene Specialist Press Ltd.

Please charge my Access/Visa/American Express/Mastercharge card

number\* .....  
(\*Delete as applicable)

Signature .....  
(Credit card orders cannot be accepted without a signature.)

Name .....

Address .....

Postcode .....

Name .....

Address .....

Postcode .....

Complete this coupon (or a photocopy of same) and send it off to YS Software, **Your Spectrum**, 14 Rathbone Place, London W1P 1DE. Please allow 20 days for delivery.

For office use only!

|  |  |  |  |  |  |
|--|--|--|--|--|--|
|  |  |  |  |  |  |
|--|--|--|--|--|--|



# ALL TIME TOP 10

| THIS MONTH | GAME                                            |
|------------|-------------------------------------------------|
| 1          | <b>UNDERWURLDE<br/>ULTIMATE</b>                 |
| 2          | <b>DALEY THOMPSON'S<br/>DECATHLON<br/>OCEAN</b> |
| 3          | <b>MATCH DAY<br/>OCEAN</b>                      |
| 4          | <b>KNIGHTLORE<br/>ULTIMATE</b>                  |
| 5          | <b>MONTY MOLE<br/>GREMLIN GRAPHICS</b>          |
| 6          | <b>JET SET WILLY<br/>SOFTWARE PROJECTS</b>      |
| 7          | <b>CHEQUERED FLAG<br/>PSION</b>                 |
| 8          | <b>SABREWULF<br/>ULTIMATE</b>                   |
| 9          | <b>ATIC ATAC<br/>ULTIMATE</b>                   |
| 10         | <b>GHOSTBUSTERS<br/>ACTIVISION</b>              |

# YS GO FOR GOLD

**If you're an all-time great games player, you could be in line for a medal. Go for it now — it's gold!**

It's all change on the YS chart this month. We've only had room to squeeze in the Top 10 because we want to tell you about how it'll look next month.

First off, there'll be two charts. One will be the YS Top 10 All Time Greats, the games you'll keep on playing for as long as the joystick holds out. The other's the YS Top 10 Hot Shots — the chart that'll bring you bang up-to-date with what you're buying now. And of course, we'll still need your votes for both of them because now they're going to be even more *your* charts.

Along with your votes for the All Time Top 10, send us

your top score and a passport sized photo of yourself. If you make it into the top three you'll not only get your piccy printed but you'll be in the running for a YS Games Gold Medal. We'll be dishing those out to the all time top scorers at the end of the year. Of course, what we don't want are any hyped or hacked high scores. You'll be found out when we invite you to the YS Games Stadium for the final play-off.

If all's not yet clear to you, look at the coupon and you'll see how to fill it in. And remember what a wacky bunch we are at YS so send us some funny photos — you can't all look like convicts, can you?

## YS Chart Challenge

My top 5 all-time greats are:

1.....  
2.....  
3.....  
4.....  
5.....

My top scores are\*:

1.....  
2.....  
3.....  
4.....  
5.....

The next games I'm gonna rush out and buy are:

1.....  
2.....  
3.....  
4.....  
5.....

\*You don't have to fill it all in but make sure you specify the level of difficulty for your scores.

I'm going for gold! My name is:

.....

Independent Witness

Name.....

Address.....

Address.....

..... Postcode .....

..... Postcode .....

Now ask an independent witness to sign the coupon.

Complete this coupon and send it to Go For Gold, *Your Spectrum*, 14 Rathbone Place, London W1P 1DE. Make sure you send us a black and white photo of yourself if you've filled in your high scores.

If you're going for gold, stick your mugshot here



# BLOCKBUSTERS

# BLOCKBUSTERS



**MACSEN**  
**SOFTWARE**

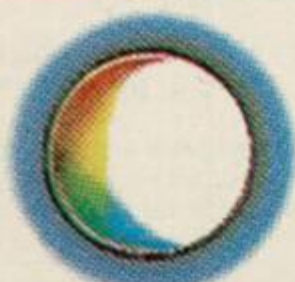
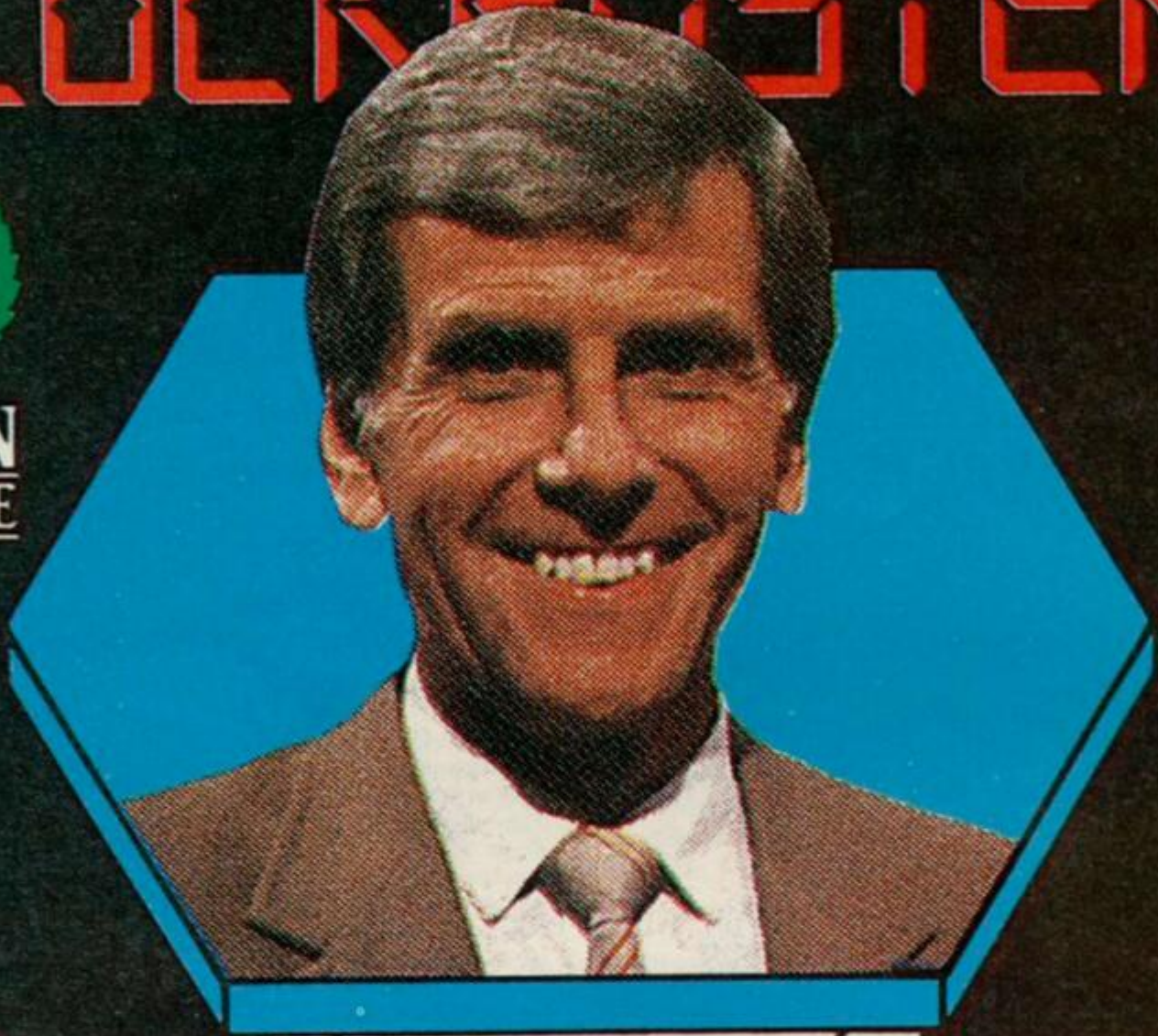

CENTRAL

**SPECTRUM**  
**48K**



## SAVE AS YOU LEARN

I've just been reading A J Unwin's article, 'Microdrivin' in issue 13 and it struck me — how about reserving lower case for the names of programs and upper case for the names of code files, screenS's or data? Also, Toni Baker's Big Deal program in the same issue could be saved as 'CARD 36102'. That way you should remember to CLEAR 36101 before loading. Pretty good, eh?

**Christopher Hopson**  
Wareham.

*Not bad, not bad. Keep those programming tips coming. Ed.*

## PENSIONED-OFF PROGRAM

As the programmer of the Quicksilva game, *Xadom*, I wish to take issue with your description of it as 'slightly geriatric'.

Wot d'ya mean, 'slightly'? It was written over *three* years ago. Let's have some respect for your elders. I prefer to call it a 'brazen oldie'.

**Mike Moscoff**  
London NW3

*OK, from now on read 'slightly geriatric' as 'pension-drawing program, that ought to have been packed off to a home aeons ago.' Happy now Mike? Ed.*

## LIFE AFTER JSW?

After all those boasting letters you at YS must have received over the past couple of months, I've got really great news! I've absolutely *no idea* where April Showers is in JSW. In fact, I must be the only Speccy user in the entire universe *not* to have JSW. Now doesn't that make you feel better? (*Yeeeah! Ed.*)

The reason for all this? Simple, there aren't that many retail outlets here on the moon! **Thomas 'Erauqs' Smith** Recently transported to Earth's little satellite.

*I think the next move you'll be making, Thomas, is off in a padded van assisted by two gentlemen in white coats! Ed.*

## PRICE HIGH, NO LIMIT

YS has gone up again and not just in my estimation, so I've written a short poem in your dishonour!

*Your Spectrum is a great magazine,  
It's the best one I've ever seen.*

# FORUM

Write to us — there's a bundle of free Spectrum software for this month's Star Letter! Write to Forum, Your Spectrum, 14 Rathbone Place, London W1P 1DE.

*Written by my heroes ("that's us" I hear you cry),  
But when I saw the March issue, I could but only sigh.  
It seems that good ol' Nigel has gone to your brain,  
you've gone and put the price up — are you insane?  
Perhaps you should state on that glossy cover of yours,  
'Price High, No Limit — just watch how it soars'.  
I hope I've made the point that I'm a penniless peruser,  
So, if you don't do something quick, I'll switch to 'Sinclair Loser'!*

**Neil McClements**  
Co. Down, N. Ireland

*OK, Neil, you've had your moan*

*Now on yer bike and push off home!*

*YS is brill for 95p,  
Who else would print that verse for free.  
(P.S. Does this make me a Po — Ed?)*

## UNLUCKY BREAK

In YS issue 13, I was lucky enough to have my letter on connecting the Speccy to a Brother M-1009 Printer chosen as the Star Letter. Thirteen still proved unlucky for some though — you slipped up while transferring the diagram to the printed page. So, here is the list of pin connection numbers as they should have appeared.

|                |   |   |    |   |   |   |
|----------------|---|---|----|---|---|---|
| Interface 1    | 2 | 3 | 4  | 5 | 7 | 9 |
| Brother M-1009 | 2 | 3 | 20 | 5 | 7 | 6 |

Of course, I don't expect this to be the Star Letter again!  
**David Poole**  
Stevenage

*Good, 'cos it ain't. But thanks for putting us right and let's hope that everyone can now make the right connections.  
Troubleshootin' Pete.*

## HOBBIT HACKING?

In a recent Hacking-Away column, Richard Glass asked for some POKES for *The Hobbit* so he can see the final screen. Well, there's not really one at all, only a bit of blurb

saying that 'You're a Master-Adventurer, and a group of elves, etc. carry you away on their shoulders.'

So Richard, if you want to be carried shoulder-high by elves, take a look at Spectrum Adventures in YS issue 9. It gives you all the help you need.  
**Darren Bates**  
Burwell, Cambs.

*Rumours are coming through that Tony 'Slim' Samuels is near to completing The Hobbit — if it's true then a lot of elves are gonna be in sore need of medical attention.  
Troubleshootin' Pete.*

## ON YER BIKE

Here's a possible solution to why Sir Clive's souped-up plastic bucket is called the C5. A friend of mine was browsing through a Z80 Assembler reference when it struck him that C5 stands for 'Push BC'. Sounds a bit like Push Bike to me. What do you think?

**K Peel**  
Brighton

*Well, there's a thing! It does to us too. Pretty appropriate as well, since any ideas of powered propulsion soon give way to pedals and pushing — usually off cliffs. Ed.*

## POKE CURTAIL

In April, someone wrote in with a quick solution to the 'line 0' problem. I've got an even quicker solution, a single POKÉ.

Just enter (after loading the header or whatever) POKÉ 23756,1, and Bob's your uncle! (*My uncle ain't called Bob. Ed.*) To make the first line of your program line zero, just enter POKÉ 23756,0.

As a bonus, here are some other useful POKÉs:

**POKÉ 23658,8** Turns CAPS-LOCK on. Just POKÉ back to zero to turn off again.

**POKÉ 23755,100** Disables List command. POKÉ to zero to re-enable.

On the subject of software protection, how about the idea

of software houses putting a bar code on the side of the package, and then producing cheap light pens to read off the code at the beginning of the program? The bar codes can't be redrawn by hand very accurately, and if they were printed red on black they wouldn't photocopy very easily either.

**Jasper**  
Bristol

*How cheap's a cheap light pen? Software's dear enough already without adding to the expense. Ed.*

## ON THE BLOWER

Here's a cautionary tale for all YS readers. I bought Cambridge Microelectronics' PROMER 815 programmers for the Spectrum a few weeks ago to program 2716 and 2732 EPROMs, but when it came, it didn't work despite what it said in the ad. After an hour or so checking the circuit, I found a dry joint which I resoldered. To program anything other than 2716 EPROMs I had to desolder 4 wire links and resolder them in different positions. Obviously, after 3 or 4 solderings the circuit board pads would come off, so I sent it back to CAMEL and asked them to supply me with a kit of parts. That way I could construct the programmer myself, incorporating switches



## TRAINSPOTTER AWARD

I'd like to claim my YS Trainspotter Award. I was looking at the brill spread you did on *Alien 8* and I couldn't believe my eyes. Lined up, with the astronauts in the activation chamber was none other than — Sabreman. I rushed to my Speccy and loaded up *Alien 8*. Then I raced off to the right room only to find that he wasn't there. Now either you've got a dicky copy or you're pulling a fast one. Please let me know because I've hunted all over the spaceship and I can't find any trace of him.

**Brian Butler**  
Rugby

*Us? Pull a fast one! Whatever next. We've even heard rumours that if you play *Alien 8* whilst there's a full moon the Werewolf puts in an appearance. If you spot him, let us know. Anyway Brian, your eagle eyes have won you a coveted Trainspotter Award. Keep on spottin'. Ed.*



# THE FABULOUS CASSETTE

# 50



VALUE that's out of this world

ONLY **£9.95**  
(INC. P&P and VAT)

**SPECTRUM 16k/48k or +**  
"Incredibly frustrating" - that's the verdict on Casette-50's FROGGER. Satisfied users tell us it's one of the most challenging you'll find - it's almost as good as the arcade version! CARGO has you trying desperately to complete your helicopter mission under attack. Plus 48 other tactical, logical and adventure games featuring multi-coloured and user-defined graphics, scrolling and full use of the Spectrum sound capabilities.

## 50 GAMES ON ONE CASSETTE

NOW AVAILABLE FOR commodore ELECTRON Atmos DRAGON BBC AIB Spectrum apple ATARI ORIC-1 ZX81 VIC-20

| No. | Game         | No. | Game         | No. | Game            |
|-----|--------------|-----|--------------|-----|-----------------|
| 1   | MUNCHER      | 16  | SKI RUN      | 36  | DRAGGOLD        |
| 2   | 3D JUMP      | 17  | TANK         | 37  | SPACE SEARCH    |
| 3   | BASEBALL     | 18  | ICE AGE SHIP | 38  | WARRIOR         |
| 4   | BRICKS       | 19  | ICE PING     | 39  | NIM             |
| 5   | CRUISER      | 20  | CARD         | 40  | VOYAGER         |
| 6   | STARTREK     | 21  | STOMPIN      | 41  | SKETCH PAD      |
| 7   | MAKINAW      | 22  | PINBALL      | 42  | BUTZ            |
| 8   | KNOCK OUT    | 23  | CAVERN       | 43  | FISHING MISSION |
| 9   | BOGLES       | 24  | LASER        | 44  | MYSTICAL        |
| 10  | ALION ATTACK | 25  | ALIEN        | 45  | DIAMONDS        |
| 11  | LUNAR LUNGER | 26  | CARGO        | 46  | GALAXY DEFENCE  |
| 12  | MAZE SETER   | 27  | THE RACE     | 47  | CYPHER          |
| 13  | MICROTRAP    | 28  | THE TALL     | 48  | ATTEMPT         |
| 14  | MOTORWAY     | 29  | ORBIT        | 49  | BARREL JUMP     |
| 15  | LASERBOMB    | 30  | MUNCH        | 50  | ATTACKER        |
| 16  | SKITTLES     | 31  | BOWLS        |     |                 |
| 17  | RACE TRACK   | 32  | RACING       |     |                 |
|     |              | 33  | FIELD        |     |                 |

50 GAMES ALSO AVAILABLE FOR ZX81  
WE PAY TOP PRICES FOR TOP QUALITY GAMES

### EXPRESS DELIVERY-ORDER NOW

Name \_\_\_\_\_  
Address \_\_\_\_\_  
Post Code \_\_\_\_\_  
Country \_\_\_\_\_ YS 5/85  
Dealers & Stockists enquiries welcome.

Postage FREE. Goods will be despatched within 7 days.  
I enclose a cheque/ postal order for £ \_\_\_\_\_ made payable to Cascade Games Ltd.  
or through any Post Office by TRANSCASH (Giro No. 655 6555)  
For even faster ordering when charging to Access, Barclaycard and Trustcard Visa use our 24 hour service. (0423) 504526.  
VISA No. \_\_\_\_\_  
COMMODORE 64  VIC 20  ORIC-1  BBC AIB   
SPECTRUM  ELECTRON  ZX 81  APPLE   
ATARI  ATMOS  DRAGON   
Cascade Games Ltd.,  
1-3 Haywra Crescent, Harrogate,  
North Yorkshire, HG1 5BG, England.  
Telephone: (0423) 504526. Registered Number 175554

## Datapen

# A QUALITY LIGHTPEN for use with the SPECTRUM computer

The DATAPEN lightpen enables you to create high resolution pictures and technical layouts directly on your T.V. screen. The accompanying software allows you to draw any shape or filled area you wish, to pixel accuracy, in full colour and the results may be utilised within your own programs, e.g. for animation, or to illustrate your title pages. At just £29 inclusive, the Datapen lightpen package represents superb value - just look at the actual screen photographs and you will agree that this must be the best value for money on the market.



### PLUS: 3 SOFTWARE PROGRAMS

- Routines and ideas for your own programs. (Menus, games, music, etc.)
- User-defined graphics creation program.
- Superb full colour drawing program as illustrated in these actual screen photographs.



- Incorporates features not provided with other pens.
- Push button operation on pen - no need to use keyboard.
- Works under any lighting conditions.
- Plots to pixel accuracy.
- 20 pre-defined commands allow plotting of geometric shapes, including triangle, lines, circles, etc., text, or user-defined characters.

- Uses all paper and ink colours.
- A screen grid may be turned on and off, at will, to assist drawing.
- Flexible erase capability.
- All drawings can be saved to tape for further use.
- Plugs in direct - no batteries, additional components, or adjustments needed.
- Handbook, plus printout of routines for use in your own programs.

Send cheque or P.O. for £29.00 to: Dept. SU1 DATAPEN MICROTECHNOLOGY LIMITED, Kingsclere Road, OVERTON, Hants. RG25 3JB 0256 770488  
or ask at your local computer shop. Send S.A.E. for details. Lightpens and software are also available for BBC B, Dragon, C8M-64 and VIC-20.



to change between EPROM types. They did this reluctantly, saying that more often than not, people made a hash of building kits!

Well, I didn't — and started programming. The thing worked fine with 2716 EPROMs, and 30 hours of hard work later I found out it was all down to faulty software. The machine code driving the programmer took no account of the differing programming requirements of the 2716 and 2732 EPROMs. I've now rewritten their machine code driving routines so I can program my EPROMs without error. What do you think? CAMEL just aren't interested. **C R Lister**  
Walton, Staffs.

*Well, perhaps they will be now. Keep watching these pages. Ed.*

## MAKIN' IT SAFE

Here are a few software-protection pokes that might be of interest to my fellow Speccy owners:

POKE 23613,82- Disables the break during program execution. (If RUN, CLEAR,

GOSUB or RETURN are used it must be re-POKEd as these commands upset the value)

POKE 23613,84- Enables the break key

POKE 23756,0- Line zero

POKE 23755,100: POKE 23756,0- This will renumber the 1st line of a program to line number 25600 (PEEK 23755\*256) + PEEK 23756) making it unlistable (could be used to hide clues in an adventure etc.) and unrunable unless called by its exact line number eg. GOTO 25599 will not work if the line number is 25600. If this is used the program containing the hidden line becomes unmergable if saved as a "LINE"

POKE 23570,10- Disables the edit key

POKE 23570,16- Stops the program being listed everytime the enter key is hit

POKE 23760,X- POKEs the character X into the first character after a REM in a first line. In this way m/c can be poked into a REM statement. POKE 23659,0 (the old favourite) — Crashes the

Speccy during loading or running of a program if the break key is hit

SAVE "BASIC PROG" CODE 23552,1500- Saves a basic program as though it is m/c and if POKE 23613,0: POKE 23613,0: SAVE "BASIC PROG" CODE 23552,1500: GOTO n (where n is the line the program is to run from) the program will be loaded as if it's m/c (LOAD "BASIC PROG" CODE must be used) and it'll auto-run once loaded. If the break key is hit during loading the Speccy will perform a system reset.

So that the program doesn't reset the Speccy if the break key is hit the first line of the program should contain POKE 23613,84 of POKE 23613,82 (see first two POKEs).

**Damien Murphy**  
Co. Wicklow, Ireland

*Wow! Ed.*

## IDIOTS' GUIDE

OK, I admit it. I don't know a thing about machine code, Hex or 'nasty black hole thingies', so please, creep, crawl, could you, grovel, grovel, write for us

dim-whits, (*Now you're talking! Ed.*), a hex loader that will enable all past, present and future Hex programs to be enjoyed by even more people, even Tottenham supporters. If this could be done I'd even go as far as to say that Ed's comments are funny (*Careful. Ed.*), T.P. is as brilliant as he says he is (*Watch it. TP.*), and that Captain Critical deserves a good smack in the peripherals for being such a smart ass (I would have preferred to spell that differently) (*Such talents — spelling as well, eh? Ed.*).

Keep up with the good work (note: still more creeping), and make a few more of us Basic idiots happy.

**From a complete nutter with a name too rude to print**  
Bury St Edmunds, Suffolk.

*My mum always told me not to talk to strange men... oh, well. Unfortunately, some Hex dumps need specialised loaders with checksum facilities, etc. I suppose that it could be done with a menu driven program, but we haven't got one to hand, so it's up to the YS readership to come up with the goods. TP.*

## ON THE CARDS

For all YS readers who've typed in the Big Deal program from the April issue, I've come up with another great game that makes use of its machine-code card printing routine. It's called Chancer. The game itself is quite straightforward and full instructions are included within

the program.

The card routine should be saved just after the program and it'll be loaded automatically by it.

**David Gent**  
Newcastle-on-Tyne

*It sure looks like a great deal to us. Ed.*

```

5 CLEAR 32768: LOAD ""CODE 32768
7 INK 0: PAPER 6: BORDER 6: CLS
10 PRINT AT 0,12: INVERSE 1: "CHANCER"
20 PRINT AT 2,0: "This game is based on the
Play Your Cards Right theme."
30 PRINT " You will start with a kitty of 100
points and must try to increase this by as m
uch as possible."
40 PRINT " In this game an Ac: counts as low,
and,if a pair is turned thenyou will have a 50/50
chance of winning."
50 PRINT " During play you may change yourfirs
t card if you wish,then you will be asked for you
r bet,then for your prediction on the next card."
60 PRINT 0:"Press any key to begin"
70 PAUSE 0: CLS
150 LET stake=100: LET score=0: LET call=36102
160 DIM c(5): DIM s(5)
180 GO SUB 500
190 GO SUB 1000
200 GO TO 1500
500 REM Init
550 FOR n=1 TO 5
560 LET c(n)=INT (RND*13)+1: LET s(n)=INT (RND*4
)+1
570 NEXT n
590 IF c(1)=c(2) AND s(1)=s(2) OR c(1)=c(3) AND
s(1)=s(3) OR c(1)=c(4) AND s(1)=s(4) OR c(1)=c(5)
AND s(1)=s(5) THEN GO TO 550
600 IF c(2)=c(3) AND s(2)=s(3) OR c(2)=c(4) AND
s(2)=s(4) OR c(2)=c(5) AND s(2)=s(5) THEN GO TO
550
610 IF c(3)=c(4) AND s(3)=s(4) OR c(3)=c(5) AND
s(3)=s(5) THEN GO TO 550
620 IF c(4)=c(5) AND s(4)=s(5) THEN GO TO 550
630 RETURN
1000 REM Screen
    
```

```

1005 RESTORE 1050
1010 FOR n=1 TO 5
1020 READ y,x,n#
1030 PRINT USR call,y,x,0,0
1035 PRINT AT y+10,x+2;n#
1037 BEEP .05,n: BEEP .02,n+15
1040 NEXT n
1050 DATA 0,0,"1st",11,2,"2nd",0,10,"3rd",11,12,"
4th",6,22,"5th"
1060 PRINT AT 0,22:"SCORE":AT 1,24:score
1070 PRINT AT 3,22:"MONEY":AT 4,23:stake
1500 REM Game
1530 PRINT USR call,0,0,c(1),s(1)
1550 INPUT "Change card ? (y/n)":a$: IF a$="y" TH
EN LET c(1)=INT (RND*13): LET s(1)=INT (RND*4)+1
: GO SUB 590
1560 PRINT USR call,0,0,c(1),s(1)
1565 LET g=1
1580 RESTORE 1800
1585 INPUT "Bet ? ":m
1586 IF m<>INT m OR m<=0 THEN BEEP .5,-10: GO TO
1585
1587 IF stake-m<0 THEN BEEP .5,-20: GO TO 1585
1588 LET stake=stake-m
1590 INPUT "Higher or Lower ? ":a$
1600 IF c(g)<c(g+1) AND a$="h" THEN BEEP .3,10:
LET score=score+1: LET stake=stake+(m*2)
1610 IF c(g)>c(g+1) AND a$="l" THEN BEEP .3,10:
LET score=score+1: LET stake=stake+(m*2)
1615 IF c(g)=c(g+1) AND RND>.4 THEN BEEP .3,10:
LET score=score+1: LET stake=stake+(m*2)
1620 READ y,x
1630 PRINT USR call,y,x,c(g+1),s(g+1)
1640 LET g=g+1
1645 PRINT AT 1,24:score:" :AT 4,23:stake:" "
1650 IF stake<=0 THEN GO TO 1700
1660 IF g<=4 THEN GO TO 1585
1670 FOR n=1 TO 250: NEXT n: GO TO 160
1700 FOR f=0 TO 4: FOR n=0 TO 7: OUT 254,n: BEEP
.005,n: BEEP .005,n-20: BEEP .005,n+10: NEXT n: N
EXT f
1710 FOR n=7 TO 0 STEP -1: BEEP .1,n: PAPER n: CL
S: NEXT n
1720 PAPER 6: BORDER 6: CLS
1730 PRINT AT 15,0: " I'm afraid that the computer
has taken all your money."
1740 PRINT AT 18,0: " Play again ? (y/n)"
1750 INPUT LINE a$
1760 IF a$="y" THEN GO TO 150
1800 DATA 11,2,0,10,11,12,6,22
    
```



All the graphics packages on the market have one thing in common; the large amounts of time and effort it takes to create a decent picture. Like me, you'll probably have a fair-sized library of picture screens, each one representing several hours of careful work. But to save time, there must have been occasions when you wished you could incorporate an existing screen dump into your current masterpiece without starting from scratch.

Well, now you can. This program allows you to combine any two pictures that you've previously SAVED by SCREENS. The resulting mix can produce some very unexpected and unusual effects. And even if the finished product's not quite the masterful mosaic you'd hoped for but a bit of a mess, you can always feed it into a standard graphics program for re-touching.

And how about adding titles to your pictures? Say you've drawn a picture of Castle Rathbone — a flourish of gothic script could make all the difference.

So, if you're in the mood to add moustaches to your Mona Lisas, then you'll have some fun with this program.

### Mix those Pix

It's a tall order to fit all of the Signs of the Zodiac onto one screen. And it would have been impossible to draw each sign straight on to such a small area. To get round the problem the pictures were designed individually at full screen size, then shrunk and finally combined using this program.



The first picture is LOADED after the program is run and stored above RAMTOP. It'll then ask you to LOAD the second picture.



On the second screen you have the option of retaining the original attributes (INK and PAPER colours) or mixing the two pics in a standard INK and PAPER setting. You'll probably find that more often than not the second option gives the less confused result but it's really up to you to experiment!



Once the second picture's LOADED you can watch as the two are mixed on screen. You're then free to SAVE your new creation or tinker about with it to get the most spectacular results.

# PIC'N'MIX!

Pick up a handful of your old screen pics and mix them together to create some stunning new visuals. Chris Somerville sketches out the possibilities.

This easy-to-use program is compatible with both the 16K and 48K Speccy. Once you've typed it in you can SAVE it using SAVE "picturemix" LINE 40.

```
10 GO TO 40
20 LET aflag=1: PRINT AT 20,0:
" CHOOSE PAPER AND INK COLOURS":
INPUT "PAPER (0 to 7)?":p#: "IN
K ?":i#: IF CODE p#<48 OR CODE
p#>55 OR CODE i#<48 OR CODE i#>5
5 THEN BEEP .25,45: GO TO 20
30 LET att=VAL p#*8+VAL i#: PA
PER VAL p#: INK VAL i#: CLS : RE
TURN
```

Lines 20-30 Set up initial screen colours and attribute variables.

```
40 DATA 17,87,228,33,0,64,1,0,
27,237,176,201,17,87,228,33,0,64
,6
50 DATA 24,197,6,0,197,126,245
,26,71,241,168,119,35,19,193,16,
243,193,16,237,201
```

Lines 40-50 Data for machine code subroutine.

```
60 RESTORE : LET CL=58414: IF
PEEK 23733<>255 THEN LET CL=256
46
```

Line 60 PEEKs P-RAMT to discover whether you're using a 16K or 48K Speccy.

```
70 CLEAR CL: LET CL=(PEEK 2373
0+256*PEEK 23731)
```

Line 70 This line lowers RAMTOP to allow space for 40 bytes of machine code and room to store the picture. It again PEEKs P-RAMT to re-establish CL since this variable has been lost with the previous CLEAR command.

```
80 LET ST=CL+1: LET MX=CL+13
```

Line 80 Initialises the start of the machine code routines.

```
90 FOR I=ST TO MX+27: READ X:
POKE I,X: NEXT I
```

Line 90 POKEs the machine code into place.

```
100 RANDOMIZE CL+41
```

Line 100 Starts the randomise seed going from a specific point.

```
110 POKE ST+1,PEEK 23670: POKE
ST+2,PEEK 23671
120 POKE MX+1,PEEK 23670: POKE
MX+2,PEEK 23671
```

Lines 110-120 This POKEs the two byte value of SEED into two separate locations.

```
130 PAPER 6: INK 1: BORDER 5: C
LS
O>REM 1984 Chris Somerville
140 PRINT " PAPER 2: INK 7: BRI
GHT 1:" " PICTURE MIXER
```

```
150 PRINT " This program will
combine any two pictures or
graphic lay-outs which hav
e previously been SAVED by SCRE
EN#."
```

```
160 PRINT " You will be asked
to LOAD each picture in turn. Y
ou will LOSE the ATTRIBUTES of
the picture you first LOAD in."
```

```
170 PRINT " You can choose to
retain the ATTRIBUTES of the
picture next LOAded, or
to have your composite picture
in INK and PAPER colours of y
our choice."
```

Lines 130-170 This prints up the instructions for the use of the program. If you follow the exact spacing, you'll end up with a well laid-out screen and justified text.

```
180 PRINT AT 19,0: " PREPARE YOU
R CASSETTE & ENTER THE NAME OF
YOUR FIRST SCREEN#"
190 PLOT 1,1: DRAW 0,173: DRAW
253,0: DRAW 0,-173: DRAW -253,0
200 INPUT "Picture name":i#: IF
LEN i#>10 THEN GO TO 200
205 CLS : PRINT AT 10,10: "PLAY
THE TAPE": LOAD i#SCREEN#
```

Lines 180-205 This part of the program loads in your first SCREENS file.

```
210 RANDOMIZE 0*USR ST
```

Line 210 Stores the picture, but retains the RND properties.

```
220 CLS : PRINT " Your first
picture has been stored. No
w prepare to LOAD the second p
icture."
230 PRINT " Do you wis
h to RETAIN the AT
TRIBUTES of the second
picture?"
240 PRINT " PRESS Y (yes) O
R N (no)"
250 IF INKEY#<>" " THEN GO TO 2
50
260 LET i#=INKEY#: IF i#="" THE
N GO TO 260
270 LET aflag=0: IF i#<>"y" AND
i#<>"Y" THEN GO SUB 20
```

Lines 220-270 These lines find out if you want to keep the attributes on the second picture.

```
280 PRINT AT 21,0: " NOW LOAD TH
E SECOND PICTURE.": INPUT "Pictu
re name":i#: LET i#=""+(i# AND L
EN i#<=10): CLS : PRINT AT 10,10
: "PLAY THE TAPE": LOAD i#SCREEN#
: IF aflag=0 THEN GO TO 300
```

Line 280 Loads in the second SCREENS file.

```
290 FOR i=22528 TO 23295: POKE
i,att: NEXT i
```

Line 290 Adds attributes as necessary.

```
300 RANDOMIZE USR MX
310 INPUT "ENTER 1 to SAVE, or 0
":i#: IF i#="" THEN GO TO 310
320 IF i#="1" THEN INPUT "PICT
URE NAME?":p#: IF LEN p#>10 THE
N LET p#="" ( TO 10)
330 IF i#="1" THEN SAVE p#SCRE
EN#
340 STOP
```

Lines 300-340 Save the new mixed-up screen pic and then stop the program.

Once you've finished mixing your pics remember to re-establish RAMTOP otherwise you'll receive an OUT OF MEMORY or RAMTOP NO GOOD error. After the program has stopped you can restart by: CLEAR 32599: RUN (for 16K users) CLEAR 65367: RUN (for 48K users)



# New - the official Spectrum Upgrade!

## Turn your Spectrum into a Spectrum+ for just £20



- Professional full-size keyboard – includes 17 extra keys.
- Responsive typewriter-style action.
- Accepts all current Spectrum software and peripherals.
- Complete with 80-page User Guide and Companion Cassette.

Here's some exciting news for 48K Spectrum owners ... the official Spectrum Upgrade Kit.

The £20 Kit has everything you need to turn your Spectrum into the stylish new Spectrum+. You don't even need an understanding of electronics, just the ability to solder a few wires together! The leaflet in the kit gives clear, step by step instructions.

If you're not sure about doing it yourself, don't worry. Simply return your 48K Spectrum to Sinclair and for £30 we'll upgrade it for you.

Whichever you decide on, you'll also receive the new 80-page User Guide and Companion Cassette.

### The bigger, better Spectrum keyboard

The Spectrum+ measures 12½" x 6". It has a large typewriter-style keyboard, with hard, moulded keys.

You'll find the new keyboard has a smooth, positive action – ideal for touch-typing, word processing, simulation programs, and extended programming sessions. Two retractable legs give a perfect typing position.

There are 58 keys in all, including 17 new keys. Programmers will be pleased to see dedicated punctuation keys, a space bar, and separate shift keys for graphics and extended modes. And a reset button allows you to clear a program from your computer's memory without disconnecting the power supply.

### The official Spectrum Upgrade

Naturally your upgraded computer will accept all the peripherals in your Sinclair system - Interface 1, Microdrives and so on - as well as all

Spectrum software.

Just as important, new Spectrum software and peripherals will be designed with the Spectrum+ in mind. So the Sinclair upgrade adds stylish looks, new capabilities ... and new potential for the future.

### Included – the new Spectrum+ User Guide and Companion Cassette

The new User Guide has over 80 pages of information, including a handy BASIC dictionary. The Companion Cassette provides an interactive tour of the new keyboard, and includes three entertaining arcade games.



### TO ORDER BY MAIL:

**When ordering the Upgrade Service**, send off your 48K Spectrum to the address below, carefully wrapped, together with the completed coupon and appropriate payment. (Please do not return the mains adaptor, manual or other ancillaries.) Your upgraded computer will be despatched to you within 10 days of receiving your order.

**When ordering the Upgrade Kit**, simply complete the coupon, enclosing the appropriate payment and post it to us at the address below. Please allow up to 28 days for delivery.

**BY PHONE:** Access or Barclaycard holders can call Camberley (0276) 685311 for personal attention, 9am to 5pm Monday to Friday. Only the Upgrade Kits can be ordered by phone.

*Please note: the upgrade offer applies to working 48K Spectrum models in the UK only.*

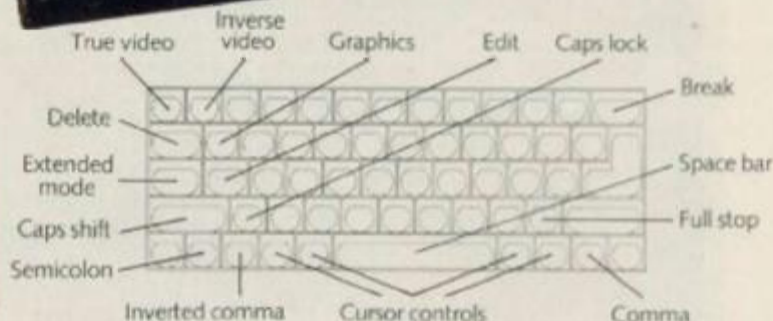

To: Sinclair Research Limited, Upgrade Dept., Stanhope Road, Camberley, Surrey, GU15 3PS.

All prices include VAT, post and packing, User Guide and Companion Cassette.

Please send me the Spectrum+ Upgrade Kit. I enclose payment of £20.

OR

Please upgrade my 48K Spectrum for me. I enclose my computer together with payment of £30.

I enclose a cheque/postal order payable to Sinclair Research Limited for £ \_\_\_\_\_

OR

Please charge my Access/Barclaycard no. \_\_\_\_\_

\_\_\_\_\_

Signature: \_\_\_\_\_

Name: Mr/Mrs/Ms \_\_\_\_\_ PLEASE PRINT

Address: \_\_\_\_\_

\_\_\_\_\_

\_\_\_\_\_

\_\_\_\_\_

\_\_\_\_\_

\_\_\_\_\_

\_\_\_\_\_

\_\_\_\_\_

\_\_\_\_\_

\_\_\_\_\_

Sinclair Research Limited,  
Upgrade Department,  
Stanhope Road, Camberley,  
Surrey, GU15 3PS.





An astronaut in a white spacesuit stands on a brown, cratered lunar surface. The astronaut's helmet visor reflects a bright orange light. In the background, dark, jagged mountain ranges rise against a light sky. The title 'NODES OF YESOD' is printed in white serif font across the dark mountain range.

NODES OF YESOD<sup>©</sup>

*Odin*  
COMPUTER GRAPHICS LTD.

SPECTRUM - COMMODORE 64 - AMSTRAD - MSX - B.B.C. MODEL B - COMPATIBLE  
TELEX 628332 GAME G TELEPHONE SALES 051-709 4462  
© "NODES OF YESOD" IS A COPYRIGHT OF ODIN COMPUTER GRAPHICS LTD



# MASTERMIND

The lights go down as you sink into the YS Mastermind chair — but the questions you answer are as tough as you want to make them. Chris Winterton has come up with a program that'll test you to the limits and make all your exam revision FUN!

Oh, groan! It's exam time again. But even worse than the exams is the revision beforehand — trying to cram the cranium with more information than it was designed to hold. Everyone's got their own way of revising for exams. Perhaps you follow the most popular method — put it all off till the night before and hope that natural ability or divine intervention will see you through. Or if that's a bit slap-dash, do you start at the beginning and plough through to the end and still find that you're faced with blank paper and a blank mind on the big day?

Either way, you're probably not having much fun at the moment, what with working or worrying about not working. But now all that's gonna

change. This program lets you revise at your own pace and in your own way. And best of all, it won't be all slog any more. Even better, you don't just have to stick to chemical formula or French verbs. What about practising your pop knowledge or kicking your fave footie teams around. Even better you can now create your own Mastermind quiz questions to torment the whole family.

## EDUCATABASE

All the information you could ever need can be stored on your Speccy — if only you were allowed to carry it into the examination room! So the problem is transferring all that info to your very own portable database, your brain. That's

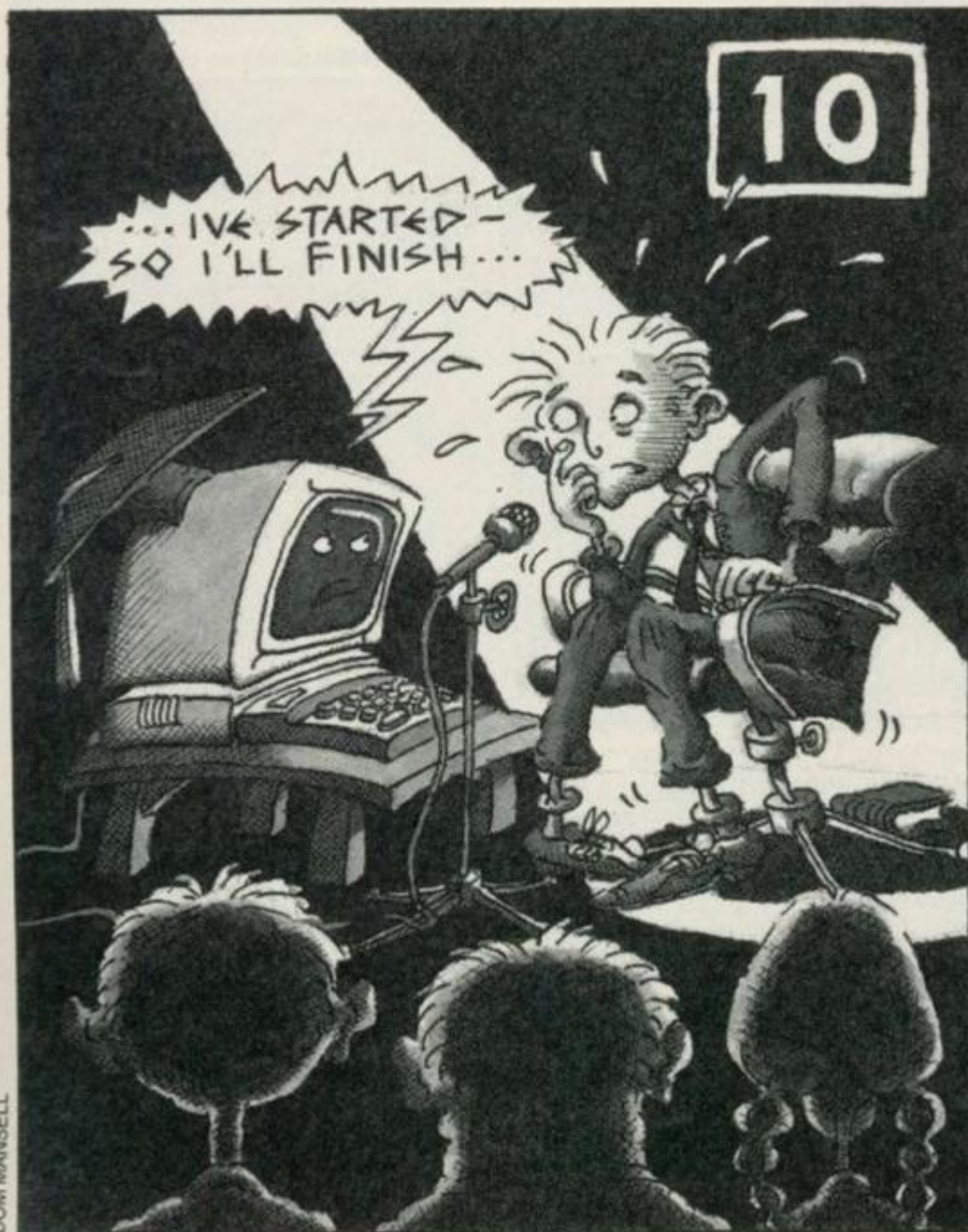

DOM MANSELL

where this program comes in. Type in all your questions and their answers or better still get someone *else* to type them in for you. Short questions and answers are best though you can go up to two lines if necessary. And remember your computer is very precise so you must answer the questions in exactly the same form as they were typed in initially — if you did it in lower case first time, do it that way all the time. You'll soon find out how best to use the program by having a go at the demo. Now I've started, so away you go and finish!

**You may not have to be a mastermind to answer the questions but it's the best way of discovering just how flexible this program is.**

```
15 LET ENTRY=20: LET SWAP=240:
LET SCORE=270: LET PRINT=210: L
ET RAND=330: LET PRESENT=370: L
ET WRONG=500: LET REPLAY=520: LET
DEMO=630: LET DISPLAY=890: LET
END=940: LET MENU=1120
```

Line 15 This line sets up the variables.

```
30 POKE 23658,8: CLS: POKE 23
607,249: PRINT INK 2: PAPER 7: V
#: POKE 23607,60: LET f#=""
```

```
          ": LET
e#="" THEN PRESS ENTER"
40 LET line=5: LET p#="" HOW MAN
Y QUESTIONS DO YOU WISH TO ENTE
R ?": GO SUB print: LET line=9:
LET p#="" TYPE IN THE NUMBER": GO
SUB print: LET line=11: LET p#=""
#: GO SUB print
50 INPUT "Number of Questions
(maximum 30) ": number: PRINT AT
5,0:f#: AT B,0:f#
60 DIM a$(number,64): DIM b$(n
umber,64): DIM e(number): REM MA
STER ARRAYS
70 DIM q$(number,64): DIM r$(n
umber,64): REM PRESENTATION ARR
AYS
80 FOR i=1 TO number
90 LET line=4: LET p#="" QUESTI
ON "+STR$ i+" OF "+STR$ number+"
QUESTIONS": GO SUB print
100 LET line=8: LET p#="" CAREFUL
LY TYPE IN YOUR QUESTION": GO SU
B print: LET line=9: LET p#="" e#:
GO SUB print
110 INPUT a$(i)
120 PRINT AT B,0:f#: PRINT AT B
,0:a$(i)
130 LET line=12: LET p#="" PRESS
ANY LETTER IF CORRECT": GO SUB p
rint: LET line=13: LET p#="" PRESS
""X"" IF WRONG": GO SUB print
140 IF INKEY#(">") THEN GO TO 1
40
150 LET i#=INKEY#: IF i#="" THE
N GO TO 150
160 IF i#=""x" OR i#=""X" THEN P
RINT AT B,0:f#: f#: GO TO 100
170 PRINT AT 11,0:f#: LET line=
12: LET p#="" PLEASE TYPE IN THE A
NSWER": GO SUB print: LET line=1
4: LET p#="" e#: GO SUB print: INPU
T b$(i): PRINT AT 13,0:f#: PRINT
AT 12,0:b$(i)
180 LET line=16: LET p#="" PRESS
ANY LETTER IF CORRECT": GO SUB p
rint: LET line=17: LET p#="" PRESS
""X"" IF WRONG": GO SUB print
190 IF INKEY#(">") THEN GO TO 1
90
200 LET i#=INKEY#: IF i#="" THE
N GO TO 200
210 IF i#=""x" OR i#=""X" THEN P
RINT AT 14,0:f#: GO TO 170
220 LET q$(i)=a$(i): LET r$(i)=
b$(i)
230 PRINT AT B,0:f#: f#: f#: NEXT
i: RETURN: REM END OF ENTRY
```

Lines 30-230 The 'Entry' subroutine, to accept your input.



# MASTERMIND

```
250 IF q#(1)=a#(1) THEN FOR i=
1 TO number: LET r#(i)=a#(i): LE
T q#(i)=b#(i): NEXT i: LET LINE=
21: LET P#="ALL CHANGED: PRESS C
": GO SUB PRINT: RETURN
260 FOR i=1 TO number: LET q#(i
)=a#(i): LET r#(i)=b#(i): NEXT i
: LET LINE=21: LET P#="ALL CHANG
ED: PRESS C": GO SUB PRINT: RETU
RN: REM END OF SWAP
```

Lines 250-260 The 'Swap' subroutine.

```
280 IF t#<u# THEN LET total=to
tal+1: LET line=20: LET p#="THA
T'S RIGHT !": GO SUB print: RETU
RN
```

```
290 IF flag=99 AND t#<u# THEN
LET g(i)=1: GO SUB wrong: RETUR
N: REM SCORE ENDS
```

```
300 IF t#<u# THEN LET e(i)=1:
GO SUB wrong: RETURN: REM SCOR
E ENDS
```

Lines 280-290 The 'Score' subroutine works out your score.

```
320 POKE 23607,249: FOR p=1 TO
LEN p#: PRINT AT line,1;p#( TO p
): BEEP .005,12: NEXT p: POKE 23
607,60: RETURN
```

Line 320 The 'Print' subroutine

```
340 RANDOMIZE: DIM f(number):
DIM a(number): FOR i=1 TO number
: LET a(i)=i: NEXT i
```

```
350 LET c=number: FOR j=1 TO nu
mber: LET x=INT (RAND*c+1): LET f
(j)=a(x): LET a(x)=a(c): LET c=c
-1
```

```
360 NEXT j: RETURN: REM ARRAY
f holds random order of numbers.
RAND ENDS
```

Lines 340-360 The 'Rand' (randomise) subroutine

```
380 POKE 23658,8: LET flag=0: L
ET total=0: DIM e(number): CLS:
POKE 23607,249: PRINT INK 1: P
APER 7:v#: POKE 23607,60: GO SUB
RAND: FOR i=1 TO number: LET cu
rrent=f(i)
```

```
390 LET line=5: LET p#="QUESTIO
N "+STR# i+" OF "+STR# number: B
O SUB print
```

```
400 PRINT AT 7,0;q#(current)
410 LET line=10: LET p#="TYPE I
N YOUR ANSWER": GO SUB print: LE
T line=11: LET p#="THEN PRESS EN
TER": GO SUB print: INPUT t#
```

```
420 LET t#<u# THEN: LET u#<r#(c
urrent, TO LEN t#): GO SUB score
430 CLS: POKE 23607,249: PRINT
INK 1: PAPER 7:v#: POKE 23607,
60: NEXT i
```

```
440 IF total<number THEN LET l
ine=5: LET p#="YOU SCORED "+STR#
total: GO SUB print: LET line=7
: LET p#="YOU HAD "+STR# (number
-total)+" WRONGS": GO SUB print:
LET line=9: LET p#="IF YOU WISH
TO TRY THE WRONG ONES AGAIN P
RESS "X" OR PRESS A
NY LETTER": GO SUB print
```

```
450 IF total=number THEN LET l
ine=5: LET p#="YOU SCORED "+STR#
total: GO SUB print: LET line=7
: LET p#="VERY WELL DONE": GO SU
B print: LET line=9: LET p#="PRE
SS ANY LETTER TO CONTINUE": GO S
UB print: PAUSE 0: RETURN
```

```
460 IF INKEY#<> THEN GO TO 4
60
```

```
470 LET i#<INKEY#: IF i#="" THE
N GO TO 470
```

```
480 IF i#="x" OR i#="X" THEN G
O TO replay
```

```
490 RETURN: REM PRESENT ENDS
510 PRINT AT 10,0:f#: LET line=
10: LET p#="SORRY THAT'S WRONG":
GO SUB print: LET line=11: LET
p#="CORRECT REPLY =": GO SUB pri
nt: PRINT AT 13,0:r#(current):
LET line=20: LET p#="PRESS ANY L
ETTER TO CONTINUE": GO SUB print
: PAUSE 0: RETURN: REM WRONG EN
DS
```

Lines 380-510 The 'Wrong' subroutine that tells you when you've answered a question incorrectly.

```
530 LET h=0: LET flag=99: LET t
otal=0: DIM g(number): CLS: POKE
23607,249: PRINT INK 1: PAPER
7:v#: POKE 23607,60: FOR i=1 TO
number: LET current=f(i)
```

```
540 IF e(i)=0 THEN NEXT i
550 LET h=h+1: LET line=5: LET
p#<u# THEN: GO SUB print
```

```
560 PRINT AT 7,0;q#(current)
570 LET line=10: LET p#="TYPE I
N YOUR ANSWER": GO SUB print: LE
T line=11: LET p#="THEN PRESS EN
TER": GO SUB print: INPUT t#
```

```
580 LET t#<u# THEN: LET u#<r#(c
urrent, TO LEN t#): GO SUB score
590 CLS: POKE 23607,249: PRINT
INK 1: PAPER 7:v#: POKE 23607,
60: NEXT i
```

```
600 LET line=5: LET p#="YOU SCO
RED "+STR# total: GO SUB print:
LET line=7: LET p#="YOU HAD "+ST
R# (h-total)+" WRONGS": GO SUB p
rint: LET line=9: LET p#="PRESS A
NY LETTER TO CONTINUE": GO SUB p
rint
```

```
610 PAUSE 0
620 RETURN: REM REPLAY ENDS
```

Lines 530-620 The 'Reply' subroutine that gives you another crack at a question when you've got it wrong.

```
640 DATA "LONDON","UNITED KINGD
OM","PARIS","FRANCE","LISBON","P
ORTUGAL","CAIRO","EGYPT","BUENOS
AIRES","ARGENTINA","STOCKHOLM",
"SWEDEN","AMSTERDAM","HOLLAND",
"COPENHAGEN","DENMARK","MADRID",
"SPAIN","WARSAW","POLAND"
```

```
650 CLS: POKE 23607,249: PRINT
v#: POKE 23607,60: LET line=5:
LET p#="DEMONSTRATION": GO SUB p
rint: LET line=7: LET p#="YOU WI
LL BE SHOWN THE NAMES OF": GO SU
B print: LET line=9: LET p#="TEN
CAPITAL CITIES": GO SUB print:
LET line=11: LET p#="TRY TO NAM
E THEIR COUNTRIES": GO SUB print
: LET line=20: LET p#="PRESS ANY
LETTER WHEN READY": GO SUB prin
t
```

```
660 PAUSE 0
670 RESTORE 640: LET number=10:
DIM a#(10,32): DIM b#(10,32): D
IM o#(10,32): DIM r#(10,32): FOR
i=1 TO 10: READ o#,n#: LET a#(i
)=o#: LET b#(i)=n#: LET q#(i)=a#
(i): LET r#(i)=b#(i): NEXT i
680 POKE 23658,8: GO SUB presen
t: RETURN: REM DEMO ENDS
```

Line 640-680 The 'Demo' subroutine.

```
900 FOR I=1 TO NUMBER: CLS: PO
KE 23607,249: PRINT v#: LET LINE
=5: LET P#=" QUESTION "+STR# I:
GO SUB PRINT: PRINT: PRINT Q#(I
)
```

```
910 LET LINE=10: LET P#="ANSWE
R "+STR# I: GO SUB PRINT
```

```
920 PRINT: PRINT R#(I)
930 LET LINE=20: LET P#="PRESS
ANY LETTER FOR NEXT": GO SUB PRI
NT: PAUSE 0: NEXT I: RETURN: RE
M DISPLAY ENDS
```

Lines 900-930 The 'Display' subroutine.

```
950 CLS: LET LINE=5: LET P#="C
OPYRIGHT": GO SUB PRINT: LET LIN
E=6: LET P#="1985 CHRIS SOMERVIL
LE": GO SUB PRINT: LET LINE=7: L
ET P#="PRESENTED IN "YOUR SPECT
```

```
RUM"": GO SUB PRINT
960 LET LINE=12: LET P#="PRESS
ANY LETTER TO CLEAR": GO SUB PRI
NT: LET LINE=13: LET P#="PRESS X
TO RESTART": GO SUB PRINT: LET
LINE=14: LET P#="PRESS C TO COPY
ON TAPE": GO SUB PRINT
970 IF INKEY#<> THEN GO TO 9
70
```

```
980 LET I#<INKEY#: IF I#="" THE
N GO TO 980
```

```
990 IF I#="X" THEN GO TO MENU
1000 IF I#="C" THEN GO TO 1020
1010 RANDOMIZE USR 0
```

```
1020 CLS: PRINT " YOU CAN MAKE
A COPY OF THIS TAPE COMPLET
E WITH ANY QUESTIONS TH
AT YOU HAVE ENTERED.
```

```
HOWEVER YOU
WILL NEED TO TYPE "CLEAR 6399
9" BEFORE YOU LOAD THE NEW TA
PE YOU HAVE MADE."
```

```
1030 PRINT " PRESS ANY LETTER W
HEN YOU ARE READY TO RECOR
D": PAUSE 0: CLS: PRINT AT 10,0
:" TYPE IN A NAME FOR YOUR TAPE
```

```
THEN PRESS ENTER": INPUT "NOT
MORE THAN 9 LETTERS": I#
```

```
1040 PRINT I: AT 0,0: " IS INT
ERFACE 1 ATTACHED? PRESS
Y(yes) OR N(no)"
```

```
1050 IF INKEY#<> THEN GO TO 1
050
```

```
1060 LET J#<INKEY#: IF J#="" THE
N GO TO 1060
```

```
1070 LET auto=23736: IF J#="y" O
R J#="Y" THEN LET auto=23794
```

```
1090 SAVE I# LINE 1100: POKE AUT
0,181: SAVE "c"CODE 64000,746: G
O TO MENU
```

```
1100 LOAD "c"CODE 64000: GO TO M
ENU
```

```
1110 STOP
```

Lines 950-1110 The 'end-the-game' routine.

```
1130 POKE 23658,8: PAPER 6: INK
0: BORDER 4: CLS: POKE 23609,35
: LET v#=""
```

HOME TUTOR PROGRAM

```
" : POKE
23607,249: PRINT v#: POKE 23607,
60
```

```
1140 PRINT "
1150 PRINT " TO ENTER QUESTION
S PRESS B"
```

```
1160 PRINT " TO TEST YOURSELF
PRESS C"
```

```
1170 PRINT " TO SWAP OVER
PRESS D (IE: QUESTIONS BEC
OME ANSWERS)"
```

```
1180 PRINT " FOR DEMONSTRATION
PRESS E"
```

```
1190 PRINT " TO LIST THE QUESTI
ONS PRESS F (TO LEARN THEM)"
```

```
1200 PRINT " TO FINISH
PRESS O"
```

```
1210 IF INKEY#<> THEN GO TO 1
210
```

```
1220 LET I#<INKEY#: IF I#="" THE
N GO TO 1220
```

```
1230 IF CODE I#<66 OR CODE I#>71
THEN GO TO 1210
```

```
1240 IF I#="G" THEN GO TO 940
1250 GO SUB (DISPLAY AND I#="F")
+(demo AND I#="E")+(entry AND I#
="B")+(present AND I#="C")+(swap
AND I#="D")
```

```
1260 IF I#="D" THEN GO TO 1220
1270 GO TO 1120
```

```
1280 STOP
1290 SAVE "n" LINE 1320: POKE 23
736,181
```

```
1300 SAVE "c"CODE 64000,746
1310 STOP
1320 PRINT AT 20,0:
1330 LOAD "c"CODE 64000
```

```
1340 PAPER 2: INK 7: CLS: FOR i
=0 TO 21: PRINT AT i,7:"STOP THE
TAPE": BEEP .1,30: NEXT i
1350 GO TO menu
```

Lines 1130-1350 The main menu subroutine menu.



★ NOW AVAILABLE FOR THE AMSTRAD CPC 464!!

# WIN THE POOLS?

SPECTADRAW 3 - THE LATEST VERSION OF THE ORIGINAL AND BEST POOLS PREDICTION PROGRAM FOR THE 48K ZX SPECTRUM!!

AND NOW... AMSTRA-DRAW - THE FIRST POOLS PREDICTION PROGRAM FOR THE AMAZING NEW AMSTRAD CPC 464!!



- Supplied with Database containing data on over 10,000 matches since 1980!
- You update the Database each week - but no tedious typing, as team and division names already in program!
- Errors easily corrected - the program even checks your entries!
- Comprehensive instruction manual and menu driven program - easy to use, even for a newcomer to computing!
- Will forecast the least likely draws for those who prefer to bet on fixed odds!
- Built in perm generator - complete your coupon direct from the screen!
- Fully microdrive compatible! (Spectadraw only).
- Compatible with Currah Microspeech - the first pools program to read you its predictions! (Spectadraw only).

Spectadraw 3 for the 48K Spectrum.....£9.95 inclusive  
 Amstra-Draw for the Amstrad CPC 464.....£9.95 inclusive  
 (Cheques/P.O.s payable to B. S. McALLEY)

We dispatch every Monday with the database made up to include all matches up to the date of dispatch.

SPECTADRAW (DeptyS), 1 Cowleaze, Chinnor, Oxford OX94TD.  
 (Tel: 0844-52426)

## UTILITIES FOR THE QL

SIX programs on one Microdrive for the Sinclair QL.

"Nothing very dramatic... could be quite useful" (PCW).

### 1 "Boot"

Displays DIRectory in columns, and allows LOADing of programs with single key-press. Without this, the directory will overflow the screen if you have more than about 18 files on cartridge; also "load mdv1-program" has 17 keypresses!

### 2 "Q Mark"

Will allow you to FORMAT a cartridge repeatedly (as recommended by SINCLAIR). You only have to enter a name and number once.

### 3 "Q Back"

Makes back-up copies of cartridges. One key-press will copy *all* files onto an *empty* cartridge, or you may single-step and choose whether or not to copy each file. If receiving cartridge is *not* empty, you will be asked whether or not to over-write any namesake of a file about to be copied. You can copy from many cartridges onto one until it is *full*.

### 4 "Q Prune"

Will delete any file with a single key-press, so *be careful* with this one!

### 5 "Q Print"

It spools files the printer.

### 6 Tool

Tool kit for programmers

### Instructions

On Paper and in a QUILL file (for when you lose the paper!). *All six programs*, will work with the extra microdrives if you get them, and have been successful with cartridges holding over 60 files each.

£7.50 from

**WD SOFTWARE (YS)**

**Hilltop, St Mary, Jersey, C.I.**

**Tel: (0534) 81392.**



# The Quill & The Illustrator

The Graphic  
Adventure Writing System  
For The 48K Spectrum

The Quill £14.95

(Also available for: CBM64  
cassette £14.95, Disk £19.95 and  
Amstrad cassette £16.95)

The Illustrator £14.95

**GILSOFT**  
30, Hawthorn Road  
Barry, South Glam  
0446 - 732765

From Computer shops Nationwide  
Or direct from us by post or phone  
Credit Card Order Line Staffed 24 Hours Daily

0222 - 41361 Ext 430



# SPECTRUM ADVENTURES

There's something so monstrous happening in Castle Rathbone you may not be able to read on. ugh, it's horrible ... it's Peter Shaw ...

I hope by now you'll have grasped the ideas that we've covered so far, on layout, structure and understanding within an adventure program. Well, this month, I'm going to give you the low down on monsters.

In the same way that room storage is done by array structures, both monsters and objects can be held in the arrays M(), MS(), O() and OS() respectively, that is an array for position, and then an array for the name of each. All you need now is a For/Next loop at the end of your program with all your monster and object information stored in data statements. Right, got that? Let's take a look at monsters first — ugh! Say you wanted three of them called Hurgie, Lurgie and Kevin. (Oh, very amusing! Ed.) You'll have to define your arrays M() and MS() in the following way:

```
DIM M(3): DIM MS (3,32)
```

Take the array M(). This number would hold the

position of monster number x in M(x). If M(x) equals zero then that means your monster is no more, deceased, dead. Simple, huh? In MS(), you only need to store your monster's name, so our three elements of MS(), for this example would look something like this:

```
MS(1)="HURGIE"
MS(2)="LURGIE"
MS(3)="KEVIN"
```

And that's about it. In your data array, all you do is put the monster's position in M(), and the monster's name in MS().

Objects are slightly more complicated. Say we had four objects in this imaginary adventure. A key, a ring, a headband and a floppy hat. O() and OS() would be dimensioned as follows:

```
DIM O(4,2): DIM OS(4,32)
```

You've probably guessed already that OS() simply holds the name of the object in the same way that MS() just holds the name of a monster. But why, I hear you mutter, does O() need two parts to each

element? Well that's because objects can usually have two states, a bit like a lever can be either up or down. So, in the second part of each element we can describe what state it's in. But, you're muttering again, what if we make the position of the object zero — will that mean it's dead like the monster. No, of course not, if the position of the object is zero it means you're carrying it!

Right, now all you've got to do is work this into your own adventure. I'm sure you're on the ball enough to realise that you'll have to make checks during the running of the program to see if there's an object or monster in the room, and then make a decision about what to do — fight the monster, or pick up the object.

Next month, for the lost, confused or just plain lazy there'll be the final part of Routine Adventures and we'll be presenting you with the adventure to end all adventures. See ya there!

## GIVE US A CLUE

We all know just how frustrating it can be when you're stuck in an adventure. Your head starts to spin thinking of all the different possibilities for solving a particular problem. Sometimes, it's a case of give up or go ga-ga. What's worse is the fact that you know someone somewhere has cracked it. And chances are they're a YS reader too. Well, now's your chance to get in touch with the person who can put you out of your misery.

If you have a problem in an adventure, send it in and when it's printed, just wait and see the solutions come rolling in.

Of course, the other side of the coin is the adventures you've already solved. You can bet there's gonna be someone stuck in a game you completed yonks ago. In which case let us know which games you can help with and we'll print your name and address so people can contact you. There'll even be three pieces of adventure software for our Star Helper each month, so jot down any really clever clues you've come across.

This new YS service is really about putting people in touch with one another. And it could be a great way of making new friends as well. All you have to do is fill in the coupon below and send it off to Give Us A Clue, *Your Spectrum*, 14 Rathbone Place, London W1

## GREMLINS

Adventure International/£9.95

If bustin' made you feel good, how d'you fancy mincing up little green gremlins in the kitchen blender? Well, you can in Adventure International's adventure game of the film, *Gremlins* — it has graphics that move, so you can see one of the little monster's legs turning while his brains are blended. All in the worst possible taste!

The graphics are certainly the most stunning feature of the game. You can slice the head off another gremlin with a sword and see his head land up in the fireplace. Cook another one in the microwave. And they reckon the gremlins are the blood-thirsty ones!

The number of locations isn't that huge but you don't get that much time to explore them. Every move you make means the gremlins have more time to get together and gang up on you. So, you'll have to find ways of

keeping them occupied (they love watching movies, for example) before they overrun the town. As you become engrossed in the adventure the tension certainly mounts — you know that every move you make could be your last.

*Gremlins* shares a number of annoying features with other Adventure International games — it won't accept short forms of words and you have to GO everywhere — GO WEST, GO DOOR, GO UP! Nevertheless, it's a slick bit of programming with an exciting story line.

This isn't an adventure for the addicts but if you're new to the games or you've seen the film this offers a good dollop of gruesome fun!



## GIVE US A CLUE

OK, I give up/I'm the world's No 1\* on

.....

Here's my problem/clues\*

.....

.....

.....

.....

Name .....

Address .....

.....

Phone.....

And I can be contacted there from ..... (am/pm)

Fill in the coupon (or a photocopy) and send it to Give Us A Clue, *Your Spectrum*, 14 Rathbone Place, London W1P 1DE.



THE *Only* REALISTIC

# BASKETBALL

ACTION PROGRAM FOR YOUR CBM 64

**NOW**

AVAILABLE ON  
SPECTRUM 48K  
AMSTRAD CPC464  
ATARI 600/800XL  
(CASSETTE & DISK)  
including FREE  
ENAMEL METAL BADGE  
OFFER

NO. 2. U.S. HIT

OUT NOW ON CASSETTE & DISK

## ONE-ON-ONE



THIS PROGRAM HAS BEEN PERSONALLY DESIGNED BY TOP U.S. BASKETBALL SUPERSTARS OR JULIUS ERVING & LARRY BIRD AND IS BASED ON THEIR REAL GAME MOVEMENTS.

Fast Load Chrome Tape

A Basketball Action program for the COMMODORE 64 U.S. No. 2 HIT

INCLUDES SPECIAL DISCOUNT VOUCHER



Basketball fans should love this simulation of the game — It has some of the most lifelike animation ever seen in a sports game —

■ To see your player spin 180 degrees, dribble past the defender and shoot close in, gives a vicarious thrill quite unmatched in any other sports simulation I've seen.

■ All this adds up to one heck of a great game.

Bob Chappell  
Personal Computer News

- FEATURES • PLAY THE COMPUTER LEVELS • BUILT IN FATIGUE FACTORS • STREAKS - FOULS - A STOP CLOCK - AND A REFEREE
- INSTANT ACTION REPLAY • JOYSTICK CONTROL\* • OR A FRIEND • 4 SKIL

AVAILABLE FROM ALL GOOD SOFTWARE RETAILERS - IF IT'S NOT THERE PLEASE ORDER IT





# PAINTING BY NUMBERS

Forget the pens and paintbrushes — how about painting with pixels? Penny Page has taken a peek at four new graphics packages and Peter Shaw completes the picture.

First off, the sixty-four thousand pixel question — why do you want to draw pretty pictures on the screen? Of course, there's always the art for art's sake answer. After all, why do artists draw pictures anyway? The average artist can fork out quite large portions of his pocket-money on pens and paintbrushes, but at least you won't have to keep replacing your software. But if you're not that arty-farty how does the idea of making money grab you? Thought so. Well, I know of people who have sold their computer masterpieces to software houses who've used them as

## Leonardo

Creative Sparks £9.95

## Lightmagic

New Generation Software £14.95

It may not look like much to you, but considering the snail's pace the cursor travels round the screen and the age it took to produce, I'm quite pleased with it. Shame I can't say the same about the package.

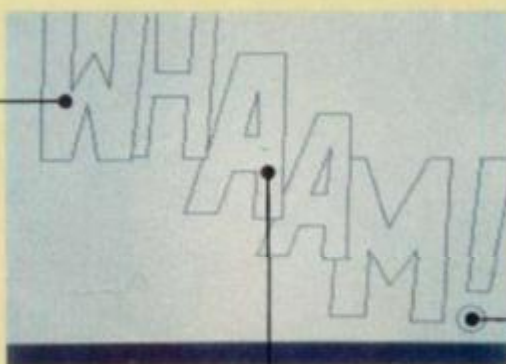

Wow, my first chance to draw a perfect circle. After working through the hefty 99-page booklet, I got the impression that this is considered an advanced feature!

1

Leonardo's line drawing facilities are nothing special. I'd plump instead for any one of the other three packages. It got really tedious twiddling my thumbs, waiting for the cursor to shift down to the next point. It seems that a fair chunk of Leonardo's written in Basic including the cursor going on its speed!

Leonardo's got a very complex enlarge facility — not nearly as good as, say, Paintplus's. Once you've sussed out what the manual's trying to say the enlarge feature seems a doddle — in practice though it's a bit of a nightmare.



Drawing curved lines with Leonardo's surprisingly simple. I imagined — after the trouble I'd had with the straight ones — that this would be a desperate task. As you can see though, they ain't that bad, after all.

2

Creating this background turned out to be a lot simpler than I first thought. Once I'd read through the bit in the manual on textures about ten times, I got a vague idea of what they were driving at. Still, it took a fair bit of time. Thank goodness there's a good 'erase' facility.

Adding colour to the picture wasn't as bad as with Lightmagic — but it still wasn't much cop though. Mind you, the overall effect doesn't look too bad with the colour added, I suppose.



The textures facility's pretty flexible — more so than any of the other's hatch-fill options. It still needs a fair bit of grey-matter application to master it. I got a bit carried away with it here!

3

Leonardo's much the same as Lightmagic in its low-resolution grid operation. In fact, it has two modes to help you get the best out of the attributes. The first super-imposes a bright/normal grid over your picture to show you where the character cells are. The other offers a cursor the size of a character square.

I drew these lines with the 'Band' facility that allows you to move the line into exactly the right position before making it permanent.

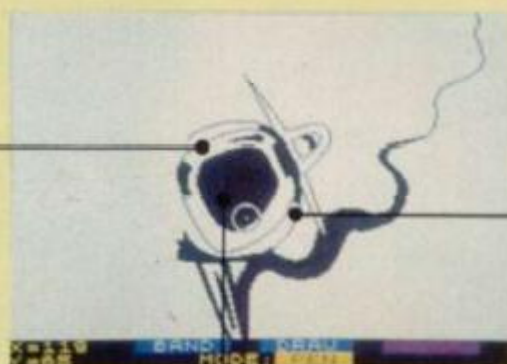

Lightmagic's colour handling leaves a lot to be desired. I had to decide exactly which colour I wanted each part of the picture before I set about drawing anything. Here I'm just using black lines.

1

Lightmagic's FILL command performs only a solid fill — a shame but it can cope with quite complex shapes in just one go. Still, you can get round its inability to perform a hatched fill by using either the airbrush mode or copy command.

No-one could possibly call Lightmagic's colour handling easy. Still, the program does include a feature that superimposes a low resolution grid on-screen. You can then draw lines so they don't clash too much when adding colour.



Lightmagic has a 'variable brush size' feature that lets you use a brush from zero to twenty pixels wide. It's a pity that this was let down by the poor quality of the cursor in brush mode. From then on it was a bit hit or miss whether I got my lines drawn where I wanted.

2

One bit of the program I called into play a number of times, was the 'Save/Recall Picture' feature. This lets you either save or recall the current picture up in high memory. Pretty useful, as no 'erase' operation was included, so I used it each time I made any major changes.

So now I've got all I want in black. Time to add the other colours. Adding the paper colours is the most tiresome part of the job. If you take a close look you'll see this wasn't one of my greatest successes.



The final effect's OK and considering all the obstacles I'm quite chuffed with it. Underneath, however, there's a hell of a mess where I've tried to cope with the bad attribute handling.

3

Lightmagic hasn't got a hatch-fill facility. To get round this, I tried the airbrush mode but made a complete hash of it. I did it eventually by drawing a small section of hatching, and then copying it with the 'cut-and-paste' commands. The rough edges were tidied up with the enlarge facility.

Leonardo's definitely aimed at the novice artist. It includes a 'programmable draw' feature that lets you draw all sorts of shapes. In fact, it's a bit like *Squirrel* which we published in *Program Power* a couple of months ago! The worst bit's growing old waiting for it to perform even the simplest operations. OK, it's not a crime to write in Basic, but the cursor... well, I mean.

Picture Completion Time 4½ hours Rating 1½/5

Lightmagic is aimed at the less talented artist. It's got a lot of good, easy-to-use features but they're not really cut out for 'real' drawing. Sure, you can create abstract pictures with ease but that's not what we're after here. It will handle the basic framework quite well but it comes a cropper on the old attributes. Not one for the experienced graphic designer.

Picture Completion Time 3½ hours Rating 3½/5



title screens for games. You don't have to be a poor artist! But the best reason of all is that drawing with your Speccy can be real fun. And if you don't rate yourself as much of an artist, you'll still be able to knock up some professional looking graphics with your Speccy's help. Beats staring at a blank sheet of paper any day!

### ART WORK

Every art form has its limitations and computer art's no exception. Your Speccy hasn't got an infinite number of pixels to draw with and your colour palette's pretty small. You can always

mix a hue on screen with the aid of a grid pattern and clever use of colours but this only highlights the problem of the low-resolution attribute grid. All sounds a bit grim, doesn't it? But don't despair, 'cos a quick butchers at Pete's piccies will show you what's possible.

All of the packages Peter picked to produce his piccies (*OK, you can untwist your tongues now! Ed.*) are new to the market, though *Paintplus* has arisen from the ashes of P'n'P's previous package, *Paintbox*. All the software we looked at offers improvements on previous graphics programs but none of

them has got it completely right yet. They're either too complicated or they miss out on one important feature or another. Take for an example, the idea of adding colour. A painter would usually draw a rough sketch on the canvas first and then slap on the colour afterwards. But with three of these packages you've got to choose your colours and put them on without any previous drawing. Only *The Artist* has got it right.

### DRAWING THE LINE

One of the major problems about creating pictures on the Speccy is the distance

14.95

## PaintPlus

Print 'n' Plotter £9.95

The first tricky bit was sketching in the basic lines. No variable brush size feature here, so these lines had to be drawn in outline, and then filled in.



*Paintplus's* FILL command is fast — it's just a shame it's not more reliable. As it admits in the manual, unless you're trying to fill a square or circle, then it's unlikely to get everything in first go.



*PaintPlus* is very helpful when it comes to taking out the inevitable cock-ups — well, they're inevitable when I'm around. Apart from the basic 'erase last operation' facility, *PaintPlus* also allows you to save a copy of the screen to high memory before setting out on any major changes.

I did the girl's hair with the arc feature. This manual's the only one to show an example of each possible arc — a small point maybe, but you'd be surprised how handy that info is.



Hidden deep within *PaintPlus* (behind this picture if you like) is a help page that provides a summarised version of the manual's commands. It's a great feature and saves a lot of time flipping through the manual.

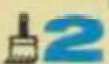

Take a look at the detail in her eyes — good, innit? Well, it was done with *PaintPlus's* enlarge facility and pretty simple it was too. First select the area of the screen you wish to enlarge by moving a box onto it. Then, press the '2' key and that area will be blown up to fill the full screen.

If you know the original painting I've copied here, you'll notice that I've back-combed her hair a touch. Still, I'm only an amateur after all!



As long as you get the ink colour right first time, the paper colour can be changed very easily using the paper wash facility. It's a pity this isn't included in the other three packages.



OK, it's a pain when *PaintPlus's* ordinary FILL command fails from time to time, but this is more than made up for by its ability to perform a hatched fill. It has eight variants in all, and they're all very effective. Other programmers take note!

*PaintPlus* isn't the most advanced of the four packages but Print 'n' Plotter have come up with a good balance between what to include and what to leave out. The package requires a modicum of talent before the best can be 'drawn' out of it.

It still comes up against competition from Melbourne Draw but the hatch fill feature means it gets my vote.

Picture Completion Time 2 hours Rating 4/5.

## The Artist

Softek £12.95

It's a doddle (*shouldn't that be doodle? Ed.*) adding colour as you go along. You can change whole blocks, or individual character squares, by Ink and Paper separately or both together.

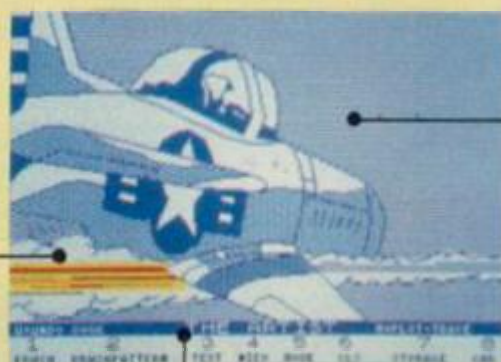

This is amazing — this screen took less than half an hour to produce. The FILL commands are wonderfully versatile and the basic lines are very easy to place and edit.



The program helps you all the time you're drawing by giving you a key guide at the bottom of the page. Simply press the symbol shift key and you can flip through the different modes of operation.

The cursor is described as intelligent. This means that it'll speed up if you hold your finger down, but if you simply press the cursor movement key, then it will only move one pixel at a time.



The enlarge facility came in very handy when I drew the pilot. As you can see, you can get quite a lot of detail in a very short time — and it's faster than an F-15 at full throttle.



I've got a hunch that the programmer of *The Artist* based much of his work on the operation of the Apple Macintosh program, MacDraw. Apart from its speed, it has so many goodies that you're bound to find one that'll help you do exactly what you want.

*The Artist's* ability to cut and paste came in very handy here when I got round to adding the final colours. I could move parts of the picture a couple of pixels in any direction, so they affect the attribute problems as little as possible.



*The Artist's* most powerful feature is its pattern fill command. Take a good look at this piccy and you'll realise it's a little more than shading effects. *The Artist* also lets you create your own patterns or even choose a random pattern from ROM!



I've got to admit that I would have had difficulty producing a reproduction this good on paper. *The Artist* allowed me to chop and change a lot more easily than a rubber. Also it's advanced colour editor means I could try different colours in different areas, and then swap them about.

*The Artist* is a pretty amazing package. Its features are powerful and easy to use. Plans are already underway to produce a mouse and/or a trackerball to work with the program. There's even talk of add-on programs that'll run in conjunction with *The Artist* like a 'Letraset' overlay database that'll allow the user to pick out icons and graphics for use in their own pictures.

Picture Completion Time 3/4 hour Rating 5/5



### SUPERCHESS 3-5

GUARANTEED TO CONSISTENTLY BEAT ANY SPECTRUM OR COMMODORE 64 CHESS PROGRAM WHATSOEVER

NEW FOR 1985



NOW ALSO  
AMSTRAD  
SUPERCHESS  
£9.95

- ★ Save Game & Program to Microdrive
- ★ On-screen clocks for tournament realism
- ★ Unique new way of setting hundreds of levels
- ★ All play within tournament time limits

#### FEATURES

- ★ Unique new way of setting levels by time gives you total control with three different options: tell the computer to match your response times, give it a time limit to play to, or give it an average time to make its moves. And you can force it to play its best move found so far...
- ★ Change sides and levels during play if required
- ★ Stop the game and change positions at any time
- ★ Set up particular games you want to try at any stage
- ★ Will recommend your best move when asked
- ★ Can be set to solve problems up to mate in four
- ★ Extensive library of opening moves
- ★ Option to determine your own display and piece colours
- ★ You can play blindfold chess
- ★ Absolutely suitable for beginners: just set the minimum move time
- ★ Fascinating self-play mode for you to study the game
- ★ TOTAL INFORMATION about the computer's thought processes, including: best line of play found so far, number of positions evaluated, depth of search, internal scoring system, display of previous moves if required, help menu if you should ever get stuck

**STRONG**—100 times faster, 1500 times more intelligent  
**FAST**—from 5 secs to the highest levels, all within tournament times  
**PENETRATING**—at tournament levels it searches at least 7 moves deep, trying tens of thousands of lines of play  
**FRIENDLY**—keeps you informed. Ideal for the expert or as a tutor for beginners  
SAVES TO MICRODRIVE TO SAVE YOU TIME

£9.95 48K SPECTRUM

DEDICATED TO EXCELLENCE IN THE GAME OF CHESS

### BRIDGE PLAYER 2

THE STRONGEST BRIDGE PLAYER YET

NEW FOR 1985



NOW ALSO  
AMSTRAD £9.95  
+ CBM 64 £9.95  
BRIDGE PLAYERS  
+ QL £19.95

BRIDGE TUTORS with full manual & set hands to teach you the game  
Beginners £5.95 Advanced £5.95  
SPECIAL OFFER  
Bridge Player 2 & both tutors £19.95

£9.95 48K SPECTRUM  
WITH EXTENSIVE MANUAL

- ★ Play a realistic game of bridge against the computer
  - ★ Computer can play as defender or declarer
- At last, here is a program with everything the solo Bridge Player ever needed: The computer generates random hands, allows proper bidding in the ACOL system including the Stayman and Blackwood conventions, and then IT TAKES YOU ON, playing both your opponents' hands. Every feature that can be packed into the Spectrum has been included in this program to give you a really satisfying and enjoyable game of computer Bridge. Play as Declarer! All Versions

#### FEATURES

- ★ Versatile bidding routines give you a worthy opponent
- ★ Study your game: post-mortem facility allows rebidding and replaying of any hand
- ★ You can review the bidding or play to previous tricks while playing a hand
- ★ Or input a hand or contract of your choice to test yourself
- ★ COMPREHENSIVE ON-SCREEN INFORMATION DISPLAYS: contract, tricks won so far, cards played in current and last trick, score
- ★ Option to **BIAS THE DEAL** to give you and your "partner" more high card points if you prefer to play as declarer

A REALLY STRONG OPPONENT  
FOR A REALLY GOOD GAME OF BRIDGE

### ASTRONOMER

THE UNIVERSE OF STARS IN YOUR OWN PLANETARIUM

NEW FOR 1985

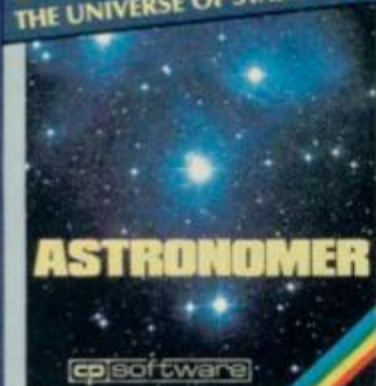

ASTRONOMER

Astronomer has everything in one powerful program... See the night sky of more than 1000 stars from any time or place on earth. Watch it plot the planets or draw in the constellations for you. See close-ups from the Star Atlas of 362 charts. Watch animated detail of our Solar System in motion and see how it changes with the months. Calculate everything needed for serious astronomy to a high standard of accuracy and produce your own tables to save having to buy them. Anything can be transferred to a ZX Printer.

#### FEATURES

- ★ Comprehensive Manual with reference sections
- ★ Suitable for serious astronomical study
- ★ Night Sky views from anywhere on earth
- ★ Works for past, present and future times
- ★ Displays over 1000 stars
- ★ Draws the constellations on your command
- ★ Plots the solar system on the night sky
- ★ Huge Star Atlas for detailed study
- ★ Shows the motion of the solar system
- ★ Calculates position for the Sun, Moon, Planets, Comets and Asteroids
- ★ Then plots them on the Night Sky or Star Chart
- ★ Displays the phases of the moon
- ★ The distance from earth of any object
- ★ Sidereal time and rising and setting times
- ★ Ephemeris section: generate and print your own tables
- ★ Fully-compatible with ZX Printer

**THRILLING** command over the night sky from any time or place on earth  
**SERIOUS** tool for the amateur astronomer — with excellent manual

"For those interested in the night sky it should prove fascinating"  
"User friendly"  
"Very good value" CRASH Oct 1984

£9.95 48K SPECTRUM

### PINBALL WIZARD

FOR COMMODORE 64 AND ANY SPECTRUM



NEW FOR  
AMSTRAD  
£8.95

SAGITTARIAN  
SOFTWARE  
For Commodore 64

Superb, colourful fast-action graphics and sound give this game the feel of a real arcade pin-table. Realistic launch, flippers, bumpers, high-score, bonus scores and freeball features. Be a Wizard!

"... I thought that a few minutes would suffice, and then found that a couple of hours had passed and I was still at it. Excellent... Pinball Wizard has it made."

CRASH MAGAZINE

"A brilliant idea that's totally absorbing and so addictive..."

YOUR SPECTRUM

"The display is well-designed and colourful and ball movement is very realistic."

PERSONAL COMPUTER GAMES

ANY SPECTRUM — £5.95  
COMMODORE 64 — £6.95 AMSTRAD — £8.95

NEW FOR OTHER COMPUTERS

AMSTRAD — Bridge Player £9.95  
Pinball £8.95  
Draughts £8.95  
Backgammon £8.95

COMMODORE — Bridge Player £9.95  
SINCLAIR QL — Bridge Player £18.95

### SUPERCODE III

FOR 48K SPECTRUM & SPECTRUM+

150 ROUTINES  
100% MICRODRIVE  
COMPATIBLE

NEW FOR 1985

With 150 ROUTINES and 100% MICRODRIVE COMPATIBILITY this has to be the ultimate Spectrum toolkit. It gives you the power to do everything you always dreamed of with your Spectrum in your own BASIC or M/C programs. Born of the earlier Supercodes (which themselves received 5 star reviews) we can claim confidence that we have packed absolutely everything into this State of The Art development. With Interface 1 it transfers easily to microdrive and is recognised by Sinclair as fully compatible. Needs no special knowledge to operate and comes with a comprehensive manual.

#### FEATURES

- ★ Unique Access Program lets you INDEX/ LIST/TEST/TAILORE/RUN/RELOCATE/SAVE (to tape or microdrive with new or default name) /VERIFY automatically
- ★ Options include EXAMPLE/REPEAT/JUMP/AGAIN/CONT/Tr/DEMO/ DIAGNOSIS/MOVE
- ★ 100% menu-driven with on-screen training
- ★ Brilliant user manual
- ★ Routines guaranteed SHORTEST AND FASTEST for all applications



#### ROUTINES INCLUDE

SUPER MICRODRIVE CATALOGUE-TRACE (with 256 preset program speeds)- SCREEN COMPRESS FOR ADVENTURES - ON ERROR GOTO- DOZENS OF RS232 AND MICRODRIVE ROUTINES- ON BREAK GOTO- THE SUPER-RENUMBER (Does everything)- VARIABLE LIST-STRING SEARCH-STRING REPLACE-PAINT FILL-S SUPERB PROGRAMMABLE SOUND EFFECTS-RECORD+REPLAY SOUND/MUSIC-CONFUSE+UNCONFUSE LISTING-REARRANGE PROGRAM CONTRACT/EXPAND PROGRAM ANALYSE-NUMBER-VAL \$COMPRESS-CHARACTER SWOP/SCRAMBLE/INVERT/ REVERSE/ROTATE-WHOLE NEW CHARACTER SET (50-FI-FLASH+BRIGHT ON/OFF/SWOP-MEMORY FREE -PROGRAM LENGTH+BLOCK LINE+ MEMORY ERASE/FILL/COPY-APPEND CURSOR- SCREEN SAVER/LOAD/SWOP/ MERGE/FILL/SEARCH-HEX -DEC+DEC-HEX CONVERTERS-REMPILL-DATAPILL-GRID-INK+PAPER CHANGE ATTRIBUTES SWOP/FILL/INVERT/RESET TAPES HEAD-READER PROGRAM PROTECT PROGRAM BREAK-IN- HEADERLESS FILE CREATE ALTOUR/IN CODE PROGRAM AS CODE-TAPE COPIER-DEFAULT MICRODRIVE DIAGNOSIS-FAST LOAD MICRODRIVE-SURE SAVE MICRODRIVE ADAPT TO MICRODRIVE-SURE CLOSE// -STRINGS-PROGRAM CASE CHANGE/SWOP-HEX LOADER ANALYSE MEMORY LINE ADDRESS -STAR/DRAW-FREE SCROLLER-24 LINE PRINTING-LOWER SCREEN CLS-NEW LOGO-PROGRAMMABLE BORDER EFFECTS-REMOVE COLOUR-RIPPLE+SHUTTER SCROLL(SL+R)- SCROLL PIXELS/CHARACTERS/ATTRIBUTES, SINGLY OR JOINTLY, UP/DOWN/LEFT/RIGHT, WITH OR WITHOUT WRAP-AROUND, IN A USER DEFINED WINDOW OF ANY SIZE POSITIONED ANYWHERE ON THE SCREEN-SPRITE EFFECTS...and many more besides.

£ 12.95 48K SPECTRUM WITH EXTENSIVE MANUAL

### Watch this space for Autumn releases

#### OTHER PROGRAMS for 48k Spectrum

Toolkit/Utility — (ALL AT £9.95)  
SUPERCODE II  
FLOATING POINT FORTH (with editor)  
INTEGER FORTH  
EXTENDED BASIC  
SNAIL LOGO (Turtle graphics)  
SOFTALK I & II (Speech Utility)  
SPECIAL OFFICER any two of these invaluable programming aids for £17.95  
Any three for £23.95 OR £1 OFF any if you also buy SUPERCODE III at £12.95  
16k SUPERCHESS £4.95  
JUPITER SUPERCHESS £8.95  
LYNX SUPERCHESS £9.95

#### Classic Games

Othello (powerful) £6.95  
Airbase Invader (Arcade) £5.95  
Golfing World (better than the ones you see heavily advertised) £5.95  
Draughts (very strong program) £5.95  
Backgammon (excellent) £5.95  
Yatzee £4.95 Bridge Player £9.95  
Superchess 3.0 £9.95

SPECIAL OFFER Any two classic games £1.50 OFF OR £1 OFF if you buy with one of our new featured programs at £9.95 (Astronomer, Bridge 2 or Superchess 3.5)

#### MAIL ORDER

Simply state which programs and send cheque, postal order or Access number (with expiry date). Telephone for instant credit-card orders. Send SAE for catalogue and return postage for submitted programs.

CP SOFTWARE, 10 Alexandra Road,  
Harrogate, N. Yorks HG1 5JS  
Tel: 0423 57089

CR1

DELIVERY by soonest post. Post free in UK. Europe add 80p per program. All other places add £1 per program for surface mail or for Airmail add £2 for first program and 50p for each additional.



## PAINTING BY NUMBERS

between the screen where the pic appears and the keyboard that creates it. This is pretty unusual — just think, if you're painting, the brushes are at least in direct contact with the canvas and a sculptor chisels and chips at his chunk of rock. Of course, a light pen seems the obvious way round but none of these packages has that facility. And have you ever tried to draw with one of them on the Spectrum — they wouldn't have persuaded Picasso to pack in his painting!

All the programs include a User-Defined Graphics editor and positioner — very useful if you want to store away complex pictures in twenty-one graphics symbols but I find this option a bit of a waste of space. Still, that's only me and if I was asked to pin down the best program on its UDG handling alone, I'd plump for *The Artist*.

Well, now for the moment you've all been waiting for — which one of the four packages would I go for on overall picture creating ability. As you probably expected I'm going to hedge my bets. My choice lies somewhere between *The Artist*, *PaintPlus* and *Lightmagic* in that order. *Leonardo* just didn't come into the running. But before you make up your mind, have a look at what Peter made of the packages and see which one would most suit your artistic temperament.

## PAINT BOX

|                          | THE ARTIST                                                  | LEONARDO                                         | PAINTPLUS                          | LIGHTMAGIC    |
|--------------------------|-------------------------------------------------------------|--------------------------------------------------|------------------------------------|---------------|
| Cut + Paste              | YES                                                         | YES                                              | NO                                 | YES           |
| Enlarge                  | VERY GOOD                                                   | POOR                                             | VERY GOOD                          | POOR          |
| Rotate/mirror            | YES                                                         | YES                                              | NO                                 | YES           |
| Variable Brush Store     | YES                                                         | NO                                               | NO                                 | YES           |
| Cursor Speeds            | INTELLIGENT                                                 | 1                                                | 2                                  | 8             |
| UDG + Text               | VERY GOOD                                                   | AVERAGE                                          | VERY GOOD                          | GOOD          |
| Scale Picture Size       | YES                                                         | YES                                              | NO                                 | NO            |
| Hatching Ability         | VERY GOOD                                                   | GOOD                                             | VERY GOOD                          | POOR          |
| Fill                     | VERY GOOD                                                   | GOOD                                             | POOR                               | VERY GOOD     |
| Manual                   | VERY GOOD                                                   | POOR                                             | GOOD                               | VERY GOOD     |
| Attribute Handling       | VERY GOOD                                                   | AVERAGE                                          | GOOD                               | POOR          |
| Erase                    | GOOD                                                        | GOOD                                             | VERY GOOD                          | AVERAGE       |
| Different Character Sets | YES                                                         | YES                                              | NO                                 | NO            |
| Special Feature          | 'Overlay' mode, Wafadrive compatible, Airbrush UDG animate. | Programmable draw, Elipse 3D drawing & windowing | 'Screen planner' Organiser program | Airbrush mode |

## BEST OF DRAWERS



Anyone who can come up with an animated graphic on a Speccy which doesn't look lost on the huge screen of the Hippodrome, has got to be worth listening to about graphics packages. That's why we asked Chi-Yeung Choy, one of the winners of the Great Animated Logo Compo to come to the YS Art Gallery and offer a second opinion.

**LEONARDO** There's a multitude of commands here — shame they're so totally confusing. It's a must to have the manual at hand at all times. I found the cursor annoying to use as it didn't have any variable speeds. For the hype surrounding the launch of this package, I don't rate it at all.

**LIGHTMAGIC** The best bit of this is the large pool of commands open to you. True, the FILL command's a bit of a let down but the BRUSH mode makes up for that. Overall, it's easy to produce instant pictures but the attribute handling can be difficult to use — still, better than *PaintPlus*.

**PAINTPLUS** This is certainly an improvement on *Paintbox*, but it's still not quite the perfect solution to artistic endeavour on the Spectrum. The attribute handling is decidedly ropery. The best bit is the enlarge feature. It's a shame that drawing is limited to lines, rectangles and circles.

**THE ARTIST** Who needs a Macintosh when you've got a Speccy and this program. There are on screen commands, a very fast and extremely flexible FILL command and even a cut-and-paste facility. All it needs is a mouse and you've just saved yourself two grand!



MO184 Professional Keyboard £49.95

## The MO184 for SPECTRUM users

### KEYS:

- ★ Low-profile Keys, only 4 mm travel.
- ★ Large keycaps.
- ★ Readable at 3 feet.
- ★ Bright colours for easy identification.
- ★ Strategically placed for easy
  - extended mode
  - delete
  - → ← ↑ ↓
- ★ Extra keys for left-handed users.
- ★ Full-size space bar.
- ★ Numeric pad with decimal point.
- ★ Double width enter keys.
- ★ Quiet action on gold contact switches.
- ★ Dedicated extended mode, delete functions available at no extra cost.

### HOUSING:

- ★ Glossy wipe - easy material.
- ★ Fully insulated no mains flying around.
- ★ Generous height and depth to House Interface 1 & power supply, WITHOUT REMOVING FROM CASING.
- ★ Large slots at rear for Spectrum and Interface 1.
- ★ Palm rest, to prevent tired wrists.
- ★ Pen holder.

### ASSEMBLY:

- ★ No soldering or knowledge of electronics required.
- ★ Full instructions supplied.

Full details on request - write or phone now!



**MANCOMP LTD.**

FREEPOST, MANCHESTER M19 3BR. TEL: 061-224 1888

Designed  
in conjunction  
with educational  
psychologists, for  
Schools and  
Colleges.

OPEN  
9.00 A.M. - 7.00 P.M.  
MON-SAT.



# 7 REASONS TO GO MICROFRAME . . .

Disc interface connects up to two mini or micro floppies.

PROM boots Disc Operating System into on-board 16K DRAM.

Decoding circuit for up to 256 I/O channels.



Easy expansion with a 5 slot card frame.

Full buffering on signal lines.

External System Reset button.

Simply plugs directly into the Spectrum.

The GORDON MICROFRAME plugs directly into the back of any Spectrum, allowing the user full control of over 256 I/O channels through its 5 slot motherboard. It also has a floppy disc controller interface which boots the operating system into 16K of memory which shadows the BASIC ROM. The operating system supports basic commands such as load, save, merge, erase, cat., open and close.

To purchase a MICROFRAME or obtain further information about all GORDON MICRO products, including the full range of interface cards, please write or telephone:

Gordon Micro Limited, 3 Callendar Rd,  
Heathfield Industrial Centre, Ayr KA8 9DJ.  
Telephone: (0292) 280467.

**GORDON MICROFRAME £149.50 (inc. VAT)  
(plus £3.00 p & p)**

MACHINE-CODED  
MAGIC  
FOR ZX SPECTRUM  
16/48K

**ZX BIG-SHOT**

**SUPER-QUALITY SUPER-PRINTER**

**COMPOSE INSTANTLY**

**IN STUNNING STYLES LIKE THESE!**

**POUR**

IT THROUGH YOUR ZX PRINTER, ALPHACOM 32, OR ANY PRINTER THAT WILL SCREEN COPY WITH USR 3766 (ROM COPY ROUTINE) ANY WIDTH...ANY HEIGHT UP TO

**10 11 12 13 14 15 16 17**

MAKE POSTERS • SIGNS • NOTICES • WALLCHARTS • BANNERS • PLAQUES • NAMEPLATES • WINDOWSTICKERS • PHOTO-REDUCE AT YOUR COPY-SHOP TO GET SUPERB QUALITY FOR TAGS • LETTERHEADS • LABELS • CASSETTE-INSERTS • TYPESETTING • ETC •

**GET SIZE AND QUALITY!**

**BUTTERCRAFT** **£5.99**

POST FREE U.K.  
EUROPE + £1  
ELSEWHERE + £2

14, WILKINSON AVENUE, BRIDLEBORN, KETTLEBY, YORKS., ENGLAND

EVER HAD ANY REAL FUN WITH YOUR COMPUTER BEFORE?

on-off  
re-set

switch  
for  
spectrum



- No more crashing from worn power supply socket
- Does not affect expansion port
- Just pushes into position does not affect spectrum or power supply lead.
- No need to remove once in position.
- Ergonomically designed - no more fumbling with power supply leads.
- Positive rocker action prevents accidental operation.
- Ideal for re-setting rom cartridge games - saves time when changing microdrive cartridges.

**£4.95**

I enclose a cheque/postal order for £\_\_\_\_\_ payable to  
TEC Publications 24 Victoria Road, Bromsgrove, Worcs.

Name \_\_\_\_\_ s

Address \_\_\_\_\_

Dealer Enquiries Welcome. Telephone (0527) 74567



```

10 INK 7:PAPER 1:BORDER 1:CL
EAR 32767
20 PRINT "JSW is loading"
30 LOAD ""CODE
98
99 REM POKEs after here
898
899 INPUT "Press ENTER to sta
rt"; LINE A#
900 RANDOMISE USR 33792

```

The Jet Set Willy loader program. Use this to get your POKEs in.

## JET SET VARIABLES

| BYTE (00-FFh) | WHAT THEY DO!                                                                                                                                                                                                                                                            |
|---------------|--------------------------------------------------------------------------------------------------------------------------------------------------------------------------------------------------------------------------------------------------------------------------|
| 00h-7Fh       | These bytes contain the background descriptions of each room. Two bits are used for each character block on screen, so you're restricted to four possible types of platform. Have a look at the <b>DESIGN A PLATFORM</b> box for a breakdown of values and what they do. |
| 80h-9Fh       | The name of the room in ASCII                                                                                                                                                                                                                                            |
| A0h-C3h       | Four sets of nine bytes describing the shape and colour of the platforms. The first byte of each block holds the attribute (colour) value, followed by eight bytes of UDG-like pixel information.                                                                        |
| C4h-CCh       | Colour and shape info for the stairway set out in the same way as the platform info.                                                                                                                                                                                     |
| CDh-D5h       | Colour and shape info for the travelators again in the same format.                                                                                                                                                                                                      |
| D6h-D9h       | This four bytes block holds details of the position and direction of the travelators (see <b>TRAVELATORS AND STAIRCASES</b> ).                                                                                                                                           |
| DAh-DDh       | A further four bytes for the position and length of the stairways (see <b>TRAVELATORS AND STAIRCASES</b> ).                                                                                                                                                              |
| DEh           | One byte for the border colour.                                                                                                                                                                                                                                          |
| DFh-E0h       | Two spare bytes.                                                                                                                                                                                                                                                         |
| E1h-E8h       | Eight bytes of pixel data to describe the shape of any possible objects.                                                                                                                                                                                                 |
| E9h-ECh       | These four bytes let the program know which room number to send Willy to when he leaves the room he's in. The order is: left, right, above and below                                                                                                                     |
| EDh-EFh       | Another two spare bytes.                                                                                                                                                                                                                                                 |
| F0h-FFh       | A series of eight two-byte pairs that describe the moving nasties in the room. Take a look at <b>JET SET WILLY'S ADDRESS</b> Book opposite for some ideas on how to get those Killer things on your screen                                                               |

# INTERIOR DECORATING

OK, we'll come clean — we did know where the extra room in Jet Set Willy was. And it wasn't long before you all found it as well. Now Dave Nicholls shows you how you can start re-arranging the furniture in Miner Willy's mansion.

Right then, get out your paint pots and wallpaper paste buckets, 'cos it's time to Spring clean the JSW mansion. All the info you'll need to start re-decorating the rooms is listed below and out of the goodness of our hearts we're going to give you the loader program which first appeared in Issue 6. (And where's your copy then? Ed.) It shouldn't take you long to decorate and add on extensions. Each room is held in just 256 bytes at location C000h and goes up in sequence at D000, E000 and so on.

Got all that? Good — now put on your overalls and get decorating!



Items collected 001 Time 7:08am  
 ? ? ? ? ? ? ?

For all of you not convinced that April Showers existed (how could you mistrust us? Ed), here's the proof.

## DESIGN A PLATFORM

| BIT PATTERN | EFFECT                                                                                                                                              |
|-------------|-----------------------------------------------------------------------------------------------------------------------------------------------------|
| 00          | This is normally blank and makes up the background for the room. Your shape description should hold zeroes — unless of course you have other ideas! |
| 01          | Sections of the screen with this bit pattern allow Willy to pass through from underneath or the side, but they'll hold Willy up if he lands on-top. |
| 10          | This bit pattern won't let Willy through no matter which direction he attacks from — a bit of a dead end all round.                                 |
| 11          | This is the bit pattern for the killer blocks — one touch and poor ol' Willy's a gonner.                                                            |

Here's the bit information for the background of each room — the wallpaper and paint job.

## TRAVELATORS AND STAIRCASES

|                   |                                                                                                                                                                                                                                                                                |
|-------------------|--------------------------------------------------------------------------------------------------------------------------------------------------------------------------------------------------------------------------------------------------------------------------------|
| 1st byte:         | This tells you the direction of the travelators and stairways — 0's for left and 1's for right.                                                                                                                                                                                |
| 2nd and 3rd byte: | Together these bytes make up a screen address for the bottom of a staircase, or the left-hand end of a travelator. The picture's built up off screen and then copied, so this assumes that the screen starts at 5E00 hex. The real address then has to have 11E00 added to it. |
| 4th byte:         | This gives the length of the stairs or travelator.                                                                                                                                                                                                                             |

This is the information you'll need to consult your own travelators and stairways. Going up!

## JET SET WILLY'S ADDRESS

All numbers are in hex:

|               |                                                                                          |
|---------------|------------------------------------------------------------------------------------------|
| 8907          | The game starts here after you've pressed enter from the logo screen.                    |
| 8922          | This prepares the moving graphics data.                                                  |
| 898B          | The subroutine here puts those wandering Willies at the bottom of your screen.           |
| 8D33          | Here the basic room platform data is put on 'screen'.                                    |
| 93D1          | Puts the objects on the screen.                                                          |
| 9534          | Handles the special case rooms. you know the ones — the master bedroom and the bathroom. |
| 9456          | This subroutine puts a 2 by 2 graphic on screen.                                         |
| 918E and 90C0 | These two subroutines are the main ones for handling the moving graphics.                |
| 8420          | A single byte containing the current room number.                                        |

Left: Here's the break-down you'll need (and probably get if you try it. Ed) of the Jet Set room information area. Just change the numbers to suit your new design scheme. The easier place to start is the [ room — that's where Dave put April Showers.



# AT LAST... THE AFFORDABLE ROBOT.

The Zero 2 Robot has arrived. It's the first truly micro robotic system available and remarkably it costs less than £100.



Controlled through a cable from your computer, it is equipped with wheels, pen, line follower and two tone horn. It will connect easily with the Spectrum, BBC B, Commodore 64 and all other personal computers with a standard 'D' type RS 232 connector.

The Zero 2 Robot will add a new dimension to your computer. It is capable of precision movement to Resolutions of 1mm and can be fitted with bump and hole sensors.

As a teaching aid it has endless applications and for P.C. users at home it's just great fun.

With additional software and some exciting new add-ons planned for later this year, the Zero 2 Robot will open up a whole new area of applications and games.

INTERGALACTIC ROBOTS LTD.,  
UNIT 208, Highbury Workshop,  
22 Highbury Grove, London N.5.

Please send me a free information pack.  
INTERGALACTIC ROBOTS LTD., UNIT 208, Highbury Workshop,  
22 Highbury Grove, London N.5.

Name \_\_\_\_\_

Address \_\_\_\_\_



# WATFORD PLUGS THE GAP



## SP-DOS Spectrum Disc Operating System

- Single Drive capacities from 200K to 800K (formatted)
- Expandable to a massive 3.2Mb (formatted)
- Turn-key System capabilities
- Disc versions of Tasword Two, Masterfile and Omnicalc 2, together worth £50 included FREE OF CHARGE
- 100% compatible with the Watford Centronics/RS232 Printer Interface
- Comprehensive manual with step by step instructions

**£99.00**  
(Carr. £2)



**£29.95**  
(Carr. £2)

## Watford Centronics/ RS232 Printer Interface

- The first and still the best Printer Interface
- Centronics and Bi-directional RS232 with full hand shaking
- Compatible with Interface 1, Interface 2, Microdrives and Watford's Spectrum Disc Operating System
- Compatible with most Professional programs
- Hi-Res screen dumps in two sizes on most dot matrix printers — a standard feature not an extra

## Professional Computing Power

Get plugged into real computing with Watford's Spectrum Disc Operating System and Centronics/RS232 Printer Interface. Professional power for Spectrum users starts at under £400 with a 200K Disc Drive, Seikosha GP100A Printer, Spectrum Disc Operating System, Centronics/RS232 Printer Interface, printer cable and Tasword Two, Masterfile and Omnicalc 2 included absolutely FREE OF CHARGE. Now all Spectrum users can PLUG THE GAP. Write for FREE leaflet on SP-DOS Spectrum Disc Operating System and Centronics/RS232 Printer Interface.

Mail Order and Retail Shop. Trade and Export inquiries welcome. Government and Educational Establishments Official orders accepted.  
Prices subject to change without notice. All goods advertised subject to availability.  
VAT: UK customers please add 15% VAT to total cost including any carriage charges.  
Overseas customers—No VAT payable  
Access Orders: Phone (0923) 50234 (24 Hrs)

## SP-DOS Disc Drive Prices

|        |                         |         |
|--------|-------------------------|---------|
| SPS2   | 200K Single formatted   | £129.00 |
| SPS4   | 400K Single formatted   | £149.00 |
| SPS8   | 800K Single formatted   | £175.00 |
| SPD1M6 | 1.6Mbyte Twin formatted | £339.00 |

(Carr. on Drives £7—Securicor)

## Printer Prices

|                                   |         |
|-----------------------------------|---------|
| Seikosha GP100A                   | £125.00 |
| QUEN-DATA DPW1120 Daisywheel      | £175.00 |
| Epson RX80                        | £229.00 |
| KAGA/TAXAN KP810                  | £235.00 |
| Epson RX80 F/T                    | £245.00 |
| Epson FX80                        | £316.00 |
| Brother HR15 Daisywheel           | £339.00 |
| Epson FX100                       | £435.00 |
| KAGA/TAXAN KP910                  | £435.00 |
| Centronics or RS232 Printer cable | £8.00   |

(Please specify which is required) Carr. on Printers £7—Securicor

 **Watford Electronics**

Shop Hours: 9am to 6pm  
Monday to Saturday



# SPACE AGE

Welcome to the YS Space Academy. Here you'll receive full in-flight training from Space Commander, Ross Holman. Master the techniques of time travelling in Starion, the stunning new 3D space game from Melbourne House. Time waits for no man, so go for it now!

Long, long ago on another computer, space was opened up for exploration. Now *Starion* leads the way into time travel on the Spectrum. It's a fast 3D game that takes you into the 4th dimension — time.

You play the part of Starion, the pilot of the SS Stardate, the first spaceship capable of time travel. Your mission is to rectify the discontinuities in the space-time continuum that've been caused by a bunch of anarchist aliens running amok. They've been taking objects of historical significance from their true time periods and placing them in another time zone. You must set about undoing the damage caused by these renegade time bandits.

Time in *Starion* is split into 243 separate zones arranged in groups of nine. Nine zones from a time grid, nine grids a

## TIME — THE FINAL FRONTIER?

This is the view from your spaceship but once you've become a proficient star pilot you'll hardly need to look out of the cockpit window. All the information for your survival in the dog-fights is displayed on the console at the bottom of the screen. Try flying 'blind' to improve your scanner reading skills — there's immense satisfaction in shooting down an enemy before you've seen him.

Here's a view of the SS Stardate, the ship that'll shape the course of history if you complete the mission. This is about the most complex graphic in the game, so it's a shame that you don't get to have a go at shooting it down!

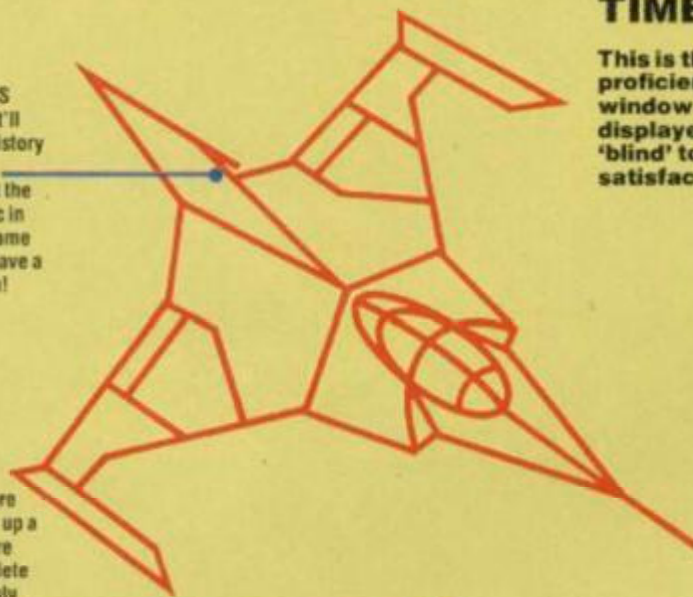

Watch out for your score — you'll need to clock up a pretty high score before you qualify for a complete re-fit of your ship. If only we knew just how high!

There are two schools of thought in the YS Space Academy about the cross-hair sights. Some reckon they're essential to line up on the enemy while others say they block the view. Luckily, you can choose for yourself as they can be turned on and off at the press of a key.

Just in case you lose track of time, the year you're in is displayed on your console.

Your spaceship's acceleration is an incredible 0-top speed in just over a second. But you're at your most vulnerable when travelling flat out, so go sparing on the old throttle. The only time you'll have to really give it some welly's when you're picking up the cargo from an alien ship.

Yaw is just the fancy term for left and right. Of course, there's not really an up and down or left and right in space but you've got to keep some bearings.

This is the cargo hold where you'll store the letters from the alien spaceships as you collect them. They'll always come up in the same order so there's no chance of the word forming as you go zapping.

The spaceship is fuelled by hydrox and although it drops more quickly the faster you travel, you won't have to stop off at any intergalactic filling stations — 'cos there aren't any.

Keep a careful eye on your hull temperature gauge. The faster you go and the more laser fire you use, the hotter things are gonna get. And if you're already burning up when an alien missile makes a direct hit, that could mean another hull blasted into oblivion. As a general guide you'll find that you're at half the max temp when travelling at top speed.

Your on-board computer will constantly keep you up-to-date on what you should be doing. If it's telling you to pick up a letter, pick it up 'cos until you do, you won't get another one no matter how many aliens you blast.

If you use the two scanners correctly, you'll be able to pin-point your position exactly. The one on the left shows the horizontal plane flying up the screen. The other covers the vertical plane, so if there's an enemy on the same level he'll appear on the right of the scanner. Don't panic, with a little bit of practice, you'll soon have it sussed.

If you're using a joystick, pull back for positive pitch (up) and push forward for negative (down).

The oxygen level's likely to cause you most trouble. It goes down at an alarming rate and when it reaches rock bottom that's goodbye to another hull. Land on a planet and you can breathe again!

Your ship rolls for just a second or so as you yaw to the left or right. Go on try it — it's the closest you'll come to space sickness!

You start off with five protective hulls around your ship but unless you're very careful they'll peel off pretty quickly. And it's no joke being naked in space!





time block and there are three of those! To complete the game you've got to trek round all of the zones patching up the holes in history. Ranged against you are the aliens in a fleet of different sized and shaped spaceships. They're lugging around with them the stolen objects that should form our heritage, but being a brainy bunch they've split each object into the different letters that spell it. Each ship then carries one letter. To sort out the shambles, you've got to blast the aliens, retrieve the letters, reform the word and then take it back to its rightful date in history. And with 243 different objects to be collected, this is not the work of an afternoon.

*Starion*'s a very fast, very playable shoot 'em up. The wire frame graphics are easily the smoothest and most realis-

tic I've ever seen on the Spectrum. But it has to be said that it won't be everyone's galactic gargle. Solving the anagrams to form the objects slows the flow of the game down and if you're not into puzzles and word-games you'll soon get cheated off with those bits. And, yes, it does look a bit too close to *Elite* for it to be a coincidence. Still, the arcade sections seem to me to be a lot faster on *Starion* even if it hasn't got quite the same in-depth game content. And after all, *Elite*'s not out on the Spectrum yet so you could always get a bit of training in, while you wait.

For all that it's a very playable arcade game — you'll soon find that reading the scanners, accelerating and decelerating and judging hull temperature is second nature to you. If you're a budding time traveller or space cadet, go for it!

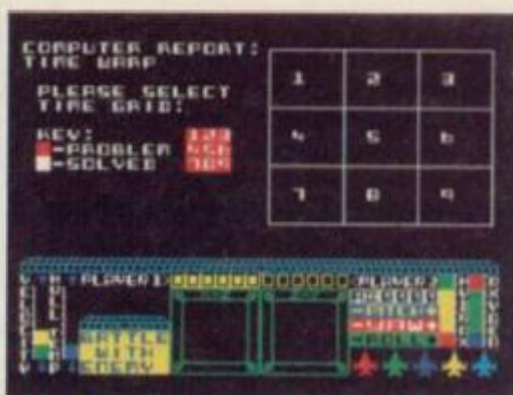

When you begin your mission this is the first screen to greet you. Choose Time Grid 1 as we've solved it for you below. Your status increases the more time zones you solve — starting as a Novice, one time zone will elevate you to a Chronotourist, three in a row and you're a Trizoner and when you've completed the whole grid, step forward a new Gridmaster!

**1**

**BATTLE WITH THE ENEMY**

After you've chosen which time period to start off in, you'll launch into the first phase of the game. As you destroy an enemy ship it'll reform into the shape of a letter that you must collect. When you have all the letters for your chosen time period, you'll be asked to re-arrange them into a word. Sometimes that's a doddle (CEE becomes EEC, for example) but others'll have you racking your brains for hours!

**6**

**DEAD BEAT**

If you die in *Starion*, this is the last thing you'll see — your coffin as it floats off into the timeless void. Get used to it, as you'll be seeing quite a bit of it in the early stages of your training period.

**2 GO FOR TIME WARP**

As soon as you've solved the puzzle of what cargo you're carrying, you'll have to make your way to the time gate. Just fly for the centre but keep an eye open for alien ships — you haven't thrown them off yet. As soon as you pass through, you'll have to make your choice of which of the other eight time zones to go for.

**3 FLY TO PLANET NOW**

Once you've chosen the new time period, fly straight to the planet. There you'll discover whether the cargo you're carrying is compatible with the puzzle that's been set. If it is, you're OK and it's off to solve another sector of the time grid. If it's not, you're given two choices. Either you can have another crack at re-arranging the letters you're carrying or you can battle on to the next time gate...

**4 BATTLE WITH THE ENEMY**

If you're carrying an incompatible cargo, you'll have to make it to another time zone — and that means fighting off the alien hordes. Just get out there and wreak havoc! There are no more letters to collect so just zap and blast your way through them until the time gate appears on your scanner. In the early stages of the game, you'll have to destroy seven of the alien ships before you can move on.

**5 GO FOR TIME WARP**

When you've solved the problems of all nine time zones, you must make a fresh word out of the initial letter of the words you've found. Only then can you pass on to the next time zone. The solution to the time grid opposite is REDBREAST — try it! Once the new word is accepted by the computer you must battle your way to the inter-grid time gate.

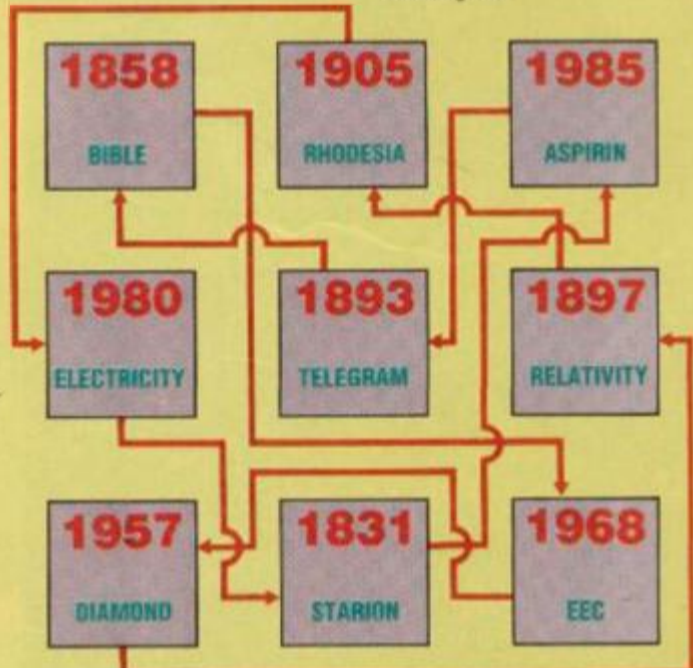

**Time Grid One — No Problem!**

So that you can concentrate on developing your flying and shooting skills, we've solved a complete time grid for you. This means that you won't have to waste precious oxygen battling for time gates after you've chosen the wrong time period. It doesn't matter where you start, just so long as you follow the course we've laid out for you.







## Let Battle Commence!

### Blast him!

Each of the enemy spaceships has its own distinct characteristics. The smaller dart-like ones are often the trickiest to take out as they're faster and more manoeuvrable. Generally, the more cumbersome the spaceship, the easier it is to blast.

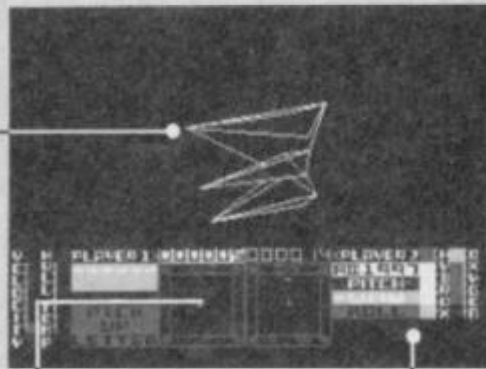

The enemy ships don't zoom in at you but zig-zag their way across the sky, so it's usually easier to keep your distance and blast them when they're just in range.

Use your lasers little and often. Firing rapidly is a great temptation but it's a sure fire way of overheating and losing hulls. Only when the spaceship is dead centre on the screen will your laser have any effect on it.

### A Close Shave

The enemy ships carry an unlimited arsenal and they're not afraid to use it. Each of the different types of ship fires a different shape missile, but they all have the same effect. If one hits you smack on, your temperature rises and you're more vulnerable to hull loss. That's why it's best to travel at slower speeds — that way your hull can absorb the rapid heat rise of a direct hit.

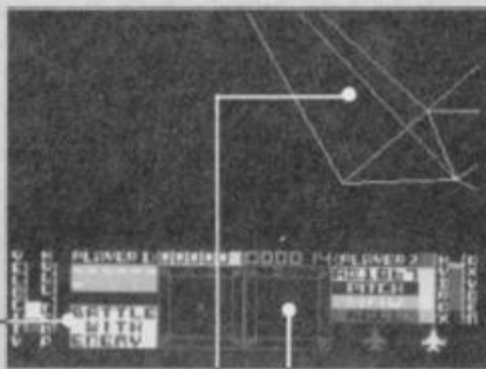

If you let the enemy get in close you may find yourself in big trouble. If you collide it's goodbye cruel world!

If a missile's coming straight for you, shoot it down. But the general rule is, take evasive action and don't go out of your way to look for them.

### Go for Cargo

Keep an eye open for the enemy because you're at your most vulnerable when travelling at top speed and in a straight line towards a letter. Close in on the cargo, get it slap bang in the middle of your screen and fly for it. There's no need to slow down or stop as it'll be picked up automatically.

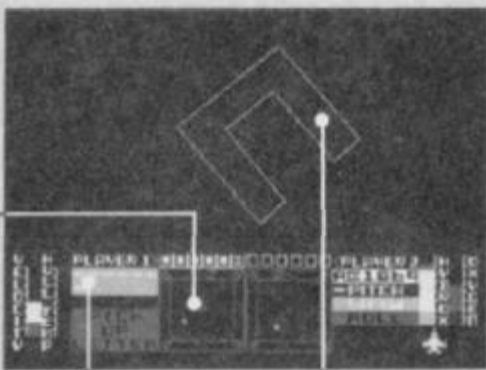

As soon as you've shot down one of the enemy it'll drop its cargo in the shape of a letter. Go straight for it rather than hanging around waiting for the next alien wave to arrive.

As soon as you've shot a ship, flip right over and you'll see the fragments form into the shape of a letter — a nice touch. Now hit the throttle and go for it — this is the only time you really ought to be travelling at full whack, 'cos if you're too slow the letter starts to back off.

### Safe Landing

You'll come across three different planetary formations — one has a single moon, another has two moons in orbit around it and the third consists of two identical octohedrons rotating round each other. All rather strange as the planet is supposed to be Earth. Still, it can be quite exhilarating getting as close as possible to a planet to watch it rotating above you.

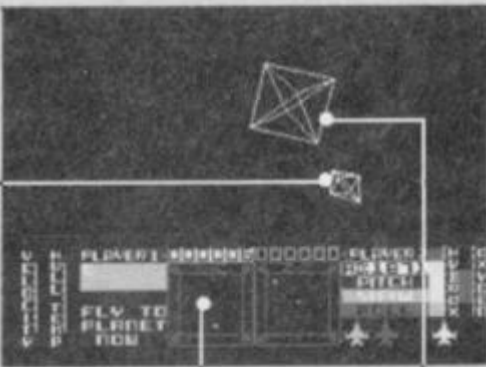

Remember that you're never free of the aliens so keep an eye on your scanner. The enemy always appears as a plus sign, missiles as dots and everything else as a minus sign.

The technique required for docking on a planet is much the same as for picking up the letters. Fly straight at it and you'll make a safe landing automatically.

# HACKER'S GUIDE

Join Chris Wood on a journey through time and space — into the centre of Starion.

From a programming point of view, two things make Starion stand out from the crowd — its 3D animated graphics and its speed. Just take a look at those spaceships move as they come towards you. They're smooth and completely shimmer free and certainly the best I've yet seen on the Speccy.

So, how's it done? Well, briefly, they're constructed using SINE tables to calculate the perspective and to give the illusion of depth. Perhaps the space-ships look a little squashed from some angles and the point of infinity is pitched a little close owing to the compact size of the programmer's universe, but these are minor criticisms. There's no over plotting here.

Speed is essential to a realistic shoot 'em up like this and the programmer's gone for it in a big way. Take a look at the way he clears the screen. The method he uses is four times faster than LDIR, the usual means of moving blocks of data, and that's certainly no sluggard!

He does it by using the Stack. It's a bit complicated but I'll have a go at explaining. First off, he saves the Stack Pointer and then moves it to the end of the screen. He then LOADs the HL register pair with zero, goes into a massive loop PUSHing HL onto the Stack. The Stack moves up the screen and down through memory and in the process, clears the screen. (You have to remember that the screen is upside down as far as memory's concerned).

Now that's an awful lot of explanation for a process that takes just 0.0067! In that time the top two-thirds of the screen is cleared which is only a quarter of the time it takes your telly to refresh the picture. Now, that's fast!

As for the 3D shapes, they're all constructed in high memory and transferred onto the screen using another version of the Stack method. In fact, he uses nearly all the alternate registers except for the two HL pairs. It all happens so swiftly that both the actions of clearing and re-drawing the screen are nigh on completed in less than the time it takes to refresh the television. And that's why you don't get any of that 'now you see it, now you don't' sort of flickering.

Now let's have a look at the

devious ways that this programmer's mind works. You only have to take a butchers at the way he's encrypted not just the passwords but even the normal game messages. He's obviously paranoid about people finding them out by PEEKing the program rather than playing the game (as if we would! Ed).

To print a message on the screen, he partially decrypts it in its original place in memory and then it's copied to a work space to be further decrypted. Connected with this, you've probably noticed that you get a momentary mess appearing on the screen when any messages are printed. This comes about because the same area of memory is used to decrypt the text as to store the screen before it's down-loaded. At least it has the effect of making you look down at your console to read a message you might otherwise have missed.

You'll probably have gathered by now that this is one programmer who knows what he's doing and isn't afraid of a bit of showing off. Take those enormous numbers that indicate every countdown, for example. The first time they appear it looks as though the machine's crashed — but you soon suss out that the numbers fill the whole screen, including the border. Very flash! It's done with a neat little Interrupt Mode 2 routine that sends bands of colours to the border in much the same way as the SAVE and LOAD commands. Only these ones are so precisely timed that they stay stationary and vary in size to make a perfect match with the rest of the shape on the screen.

After Alien 8 last month, Starion's protection was a doddle. Mind you, the complexity of the programming made it very difficult to get any more than a POKE for infinite hulls, but at least you'll have a very thick ship! Still, just to be on the safe side I've included the POKEs for infinite oxygen and hydrox.

To incorporate the POKEs I have found, type in the short program below, SAVE it before you RUN it and rewind your tape of Starion. Load that as normal until after the second short block — there is a small bit of Basic followed by some code. When it's in, stop the tape, take it out, reset your Speccy and then type in LOAD and RUN the program below. When it prints up 'LOADING', replace the Starion tape and the remainder will load and run but this time you'll have the thickest ship in the galaxy.

Oh, and by the way. When you've got to the end and reached event Zero, you're told that you are now the Creator and you're given a Richmond telephone number to ring and told to ask for God. Funny, I always thought he lived in Cambridge!

```
10 REM STARION LIVES ETC. v2
20 FOR n=65450 TO 65480: READ a: POKE n,a: NEXT n: PRINT AT 10,10;"LOADING"
40 RANDOMIZE USR 65450
100 DATA 49,0,0,221,33,0,64,17,170,191,62,255,55,205,86,5,175,50,21,179,50,235,177,62,201,50,107,178,195,67,128
110 DATA 49,0,0,221,33,0,64,17,170,191,62,255,55,205,86,5,175,50,100,179,50,7,178,62,201,50,107,178,195,67,128
```

We've seen two versions of Starion, so to be on the safe side, here's two loaders in one. First type it in without line 110 and try it. If your version crashes, replace line 100 with line 110 and the universe is yours!



# THE END OF ZX BASIC?

Single Letter Keyword Entry ...  
 Three Character Fonts ...  
 Three Character Sizes ...  
 QL-Style Windows ...  
 Named Procedures ...  
 Stippled Characters ...  
 64 Column Text ...  
 Sprites Galore ...  
 ... Upgrade Your Spectrum  
 To A MegaSpectrum—NOW!  
**ONLY £7.95!**



## YS MEGABASIC PRIORITY ORDER FORM

### SPECIAL OFFER ENDS! How to Order YS MegaBasic

Yes, this is positively your last chance to buy *YS MegaBasic* at the reduced rate of only £7.95 — that's a full £2 off the normal price of £9.95! And as this is the last ever opportunity, we're not asking you to send us any YS coupons. A cheque or Postal Order for £7.95 is your passport to MegaProgramming. So, if you've been dithering, delay no longer. Forget the coupons, just fill in the form.

Just complete the order form below (or a photocopy) and send it off to *Your Spectrum*, *YS MegaBasic Offer*, SportsScene Specialist Press, 14 Rathbone Place, London W1P 1DE. For each copy you'll need to enclose a cheque/Postal Order for £7.95, made payable to SportsScene Specialist Press. But hurry — this is your last chance at the discount price of £7.95.

| QTY   | ITEM         | PRICE | TOTAL |
|-------|--------------|-------|-------|
| ..... | YS MEGABASIC | £7.95 | ..... |

I enclose a cheque/Postal Order for £....., made payable to SportsScene Specialist Press.

Name .....

Address .....

..... Postcode .....

Phone ..... Age .....

Name .....

Address .....

..... Postcode .....

Phone ..... Age .....

Please allow 28 days for delivery.



#### MAGAZINE HEALTH WARNING

Using scissors to cut this coupon may prove hazardous to this issue's health. Why not use a photocopy instead?

### KEY FEATURES OF YS MEGABASIC

- An extended command set. *YS MegaBasic* recognises over 35 new commands, which allow you to access the new features available as well as providing the opportunity to make more of the commands in standard ZX Basic.
- 64 columns of text. Useful for wordprocessing and database applications.
- Three character sizes. Using *YS MegaBasic*, you've now the choice of accessing double-height, standard and half-width characters.
- Three character fonts. *YS MegaBasic* offers three font styles which allow your Spectrum to mimic other machines on the market.
- Windows. You can manage up to six QL-style windows on-screen at any one time.
- Sprites. Using the free *Sprite Designer* package that accompanies each copy of *YS MegaBasic*, you'll be able to design and manipulate up to ten sprites on-screen at once!
- Enhanced sound. Mike Leaman's taken the Spectrum's BEEP command and given it the full Mega-treatment.
- Procedures. Structure your programs and define new commands — it's all here!
- Stippled characters. QL-style stipples allow you to mix colours on-screen to give interesting colour effects.



# FOR CONNOISSEURS OF MODERN LANGUAGE LEARNING

COMMODORE 64 ● BBC (32K) ● ELECTRON ● SPECTRUM (48K)



Dealers, contact  
Lightning, Proteus,  
Centresoft, Microdeal  
or Tiger.

All titles are  
immediately  
available from good  
computer stores or  
by 24-hour mail  
order. Price £8.95  
(overseas  
orders add £1)

For beginners, O-level and beyond, these best-selling programs are unique and highly successful aids to language learning. Each cassette provides a comprehensive series of vocabulary lessons and a variety of self-paced learning and test modes. All accents and special characters are clearly displayed and different colours denote masculine, feminine and neuter words to reinforce gender learning.

The create command enables new lessons in vocabulary or grammar to be entered, edited as required, then saved on tape. By using this simple yet vital feature, homework lists and exam revision can be retained indefinitely and recalled on demand.

Two cassettes are available for each language, covering thousands of words; Level A provides 16 lessons in general vocabulary; Level B provides a further 16 lessons including adjectives, adverbs and fully conjugated verb lists.



KOSMOS SOFTWARE LTD 1 Pilgrims Close, Harlington, DUNSTABLE, Beds. LU5 6LX Tel: (05255) 3942

|                                                              |                                                              |                                                        |
|--------------------------------------------------------------|--------------------------------------------------------------|--------------------------------------------------------|
| The French Mistress Level A @ £8.95 <input type="checkbox"/> | The French Mistress Level B @ £8.95 <input type="checkbox"/> | Computer type.....(Commodore 64/BBC/Electron/Spectrum) |
| The German Master Level A @ £8.95 <input type="checkbox"/>   | The German Master Level B @ £8.95 <input type="checkbox"/>   | Mr/Mrs/Miss .....                                      |
| The Spanish Tutor Level A @ £8.95 <input type="checkbox"/>   | The Spanish Tutor Level B @ £8.95 <input type="checkbox"/>   | Address .....                                          |

KOSMOS SOFTWARE LTD.  
1 Pilgrims Close, Harlington, DUNSTABLE, Beds. LU5 6LX.

..... Postcode .....

## POWERFUL UTILITIES

### MAKE THE MOST OF YOUR MICRODRIVE WITH **INTERFACE III** THE IMPOSSIBLE HAS BEEN DONE

Yes it's true this fantastic new peripheral will transfer every program available on to microdrive. Yes every one. Yet, believe it or not, it is so easy to use that we are training our pet cat (Clive) to use it. Anyone capable of loading and saving a BASIC program can transfer really awkward programs to microdrive.

Just look at these features...

|                                                                       |                                                                       |
|-----------------------------------------------------------------------|-----------------------------------------------------------------------|
| Consists of hardware and software (software on microdrive cartridge). | Makes a "snapshot" of any stage of a program. (saved as a screen\$)   |
| Transfers <u>all</u> programs available on to microdrive.             | Transfer can be actuated at any stage allowing "customised" versions. |
| Very, very, easy to use. (if Clive can do it we're sure you can)      | Will also save to tape. (normal speed load once saved)                |

IF YOU HAVE A MICRODRIVE YOU MUST HAVE INTERFACE III

**ONLY £39.95 inc. P&P**  
SIMPLY AMAZING

Trade and distributor enquiries invited, U.K and overseas.

The software can be supplied on cassette for tape users.

This product is in a class of it's own. Designed by DRAYSOFT.

All prices include P&P and VAT. Send cheque, Postal Order or Credit Card No. Credit Card orders accepted by phone. Callers welcome. Wide range of goods stocked. Trade enquiries welcome. European orders send price as advertised. Outside Europe £2.00 for airmail. Mail order to Evesham Shop please.



**MICRO CENTRE**  
BRIDGE STREET, EVESHAM,  
WORCESTERSHIRE  
Tel: 0386 49641

**MICRO CENTRE**  
1756 PERSHORE ROAD,  
COTTERIDGE, BIRMINGHAM.  
Tel: 021-458 4564

### DOUBLER

THE tape backup "device".

After spectacular success on the CBM 64 and by public demand we introduced Doubler for the Spectrum. Now we have released Doubler Mk.II, which is professionally cased and has greater tolerance to the varying types of cassette decks in use.

It includes hardware and software. This superb "device" allows you to make backup copies of software with all types of loader regardless of length and speed. (Includes pulsing headers and different baud rates) In fact our tests have proved "Doubler" is capable of copying with 100% success.

Requires access to two cassette decks. The software allows you to save a brand new machine copy onto one cassette deck while loading from the other. Fast and easy to use. They said it couldn't be done.

**ONLY £14.95**  
PATENT APPLIED FOR

Customers who have the Mk.I Doubler may return it along with £4.95 for the new version.



# HOTHEADS

*If you're not that flush, but you need a printer, stay cool and go thermal. Peter Green comes in from the cold to consider the hottest ones around.*

The Sinclair ZX Printer was unique — for its size and price, it was quite a remarkable technical achievement. Still, it did leave something to be desired. All those sweaty paw prints, left all over the silver listing paper. And the print quality would strain the definition of the word adequate, as well as your eyes. Program listings on the stuff cause harassed editors to tear their hair out (or at least that's Kevin's excuse!).

One solution has been to find a way of linking 'real' printers, like the large dot matrix ones, to your Spectrum. For that you need a commercial interface, or you could have a crack at knocking up one yourself. (*Of course, you'll need a copy of YS Issue 6 for that. Ed.*)

This works, but your Speccy is now dwarfed by a huge printer — a bit of a shame when Uncle Clive has gone to so much trouble to keep it all small. And it causes even more problems if you've got to squeeze your complete computer set-up into the confines of a cramped living room — worst of all it means shelling out between two and three times as much for the printer as you paid for your Speccy. That's good enough reason for me to look seriously at thermal printers.

## ANYTHING YOU CAN DO ...

So, what can thermal printers do that dot matrix or daisywheel can't? Well, nothing really — except save you a lot of space and some cash. Most of them are quite tiny, and the good news is that they're all comparable in price to a Spectrum.

Thermal printers don't need linked ribbon because they use special paper impregnated with a heat-sensitive ink.

The print head is still 'dot-matrix' but the dots are small wires that can be independently heated. The heat makes the ink visible in the correct dot patterns to display characters. Take into account that the saving you'll make on ribbons is offset slightly by the higher cost of the special paper.

It's only got to brush its heating elements over the surface, as the print head doesn't have to strike the paper to form an image. Also, thermal printers ought to be much quieter than dot matrix ones to make its mark. Not so though, I'm afraid — to bring the price down the manufacturers often use fairly cheap electric motors to feed the paper and scan the print head, so you get a different sort of noise, but it's not quieter. It's no coincidence that the least noisy of the printers I tested was also the most expensive.

If you plump for one of the most basic of the thermal printers, you won't need an interface. They are designed as plug-in replacements and work directly from the Spectrum bus. The others have standard RS-232C or Centronics ports, so you need a printer interface as well — take this into account when you're considering your budget. For the extra though, you'll get many of the features of the big machines, including emphasised, condensed and enlarged fonts, variable line spacing, international character sets and bit image graphics.

## IN THE PICTURE

Bit image graphics means you have direct control over the heating elements in the print head. So, you can print any pattern of dots onto the paper. Interfaces such as

the ZX Lprint contain the software that uses this facility to perform a screen dump, so duplicating the COPY command. Although you'll have to bone up on the graphics modes before you get to grips with them fully (especially since most Epson-compatibles are Japanese, with manuals written in Janglish!), they do allow you to draw dot graphics of any kind, unrestricted by the Spectrum screen size or resolution. And as they all use roll paper, you could write a program that printed a frieze type of picture.

## NO LIMIT?

Bear in mind if you're considering thermals that, with one exception, none of them can handle A4 width paper, or even cut sheets. Using roll paper means that the top and bottom of your printouts have ragged edges where you've torn them off. Still, that's OK if you only want the printer for listings — or if you're happy sending out letters that look like supermarket checkout receipts.

You'll also need another spare mains socket. All but one of these printers require an external power supply, of the small transformer PSU type. Two of them can run off batteries, but they eat them and if you don't use re-chargeables, your running costs will be unbelievable.

## WHAT PRINTER?

Before choosing one of these printers, you'll have to decide exactly what you're going to do with it. If you're looking for a straight replacement for the ZX Printer, then the Floyd 40 is your best bet. Unlike the Alphacom it does a lot of clever tricks besides duplicating a Sinclair printout.

However, if you're likely to be writing letters and so forth, you'll need to look up-market a bit. There, the Epson P-40 equals the Brother HR-5 on features, but for the extra fifty quid, the HR-5 lets you use cut A4 sheets and offers the back-up of ink ribbon if you run out of thermal paper. Remember though, that you'll need an extra interface for both of them.

## HOT STUFF

|                          | ALPHACOM 32                | FLOYD 40                                                                     | EPSON P-40                                                                                               | BROTHER HR-5                                                                                                                                              |
|--------------------------|----------------------------|------------------------------------------------------------------------------|----------------------------------------------------------------------------------------------------------|-----------------------------------------------------------------------------------------------------------------------------------------------------------|
| PRICE                    | £54.95                     | £69.95                                                                       | £99.95                                                                                                   | £149.50                                                                                                                                                   |
| SIZE (mm)                | 193×143×48                 | 115×162×54                                                                   | 216×128×46                                                                                               | 303×74×65                                                                                                                                                 |
| INTERFACE                | ZX-BUS                     | ZX-BUS                                                                       | Centronics or RS232C                                                                                     | Centronics or RS232C                                                                                                                                      |
| MAX. PAPER WIDTH         | 110mm (4 1/4")             | 80mm (3 1/4")                                                                | 112mm (4 1/2")                                                                                           | 216mm (8 1/2")                                                                                                                                            |
| MAX. CHARACTERS PER LINE | 32                         | 40                                                                           | 80                                                                                                       | 132                                                                                                                                                       |
| PRINTING SPEED           | 64 CPS.                    | 33 CPS.                                                                      | 20-45 CPS                                                                                                | 30 CPS (A)                                                                                                                                                |
| GRAPHICS MODE            | Spectrum copy Command only | Spectrum copy Command only                                                   | Block Capitals<br>Bit image Graphics<br>(Requires special software to perform copy)                      | Block graphics<br>Bit image graphics<br>(Requires special software to perform copy)                                                                       |
| POWER SUPPLY             | Separate                   | From Spectrum                                                                | Internal battery plus AC adaptor                                                                         | Internal battery or AC adaptor                                                                                                                            |
| OTHER SPECIAL FEATURES   | None                       | Can automatically word-wrap text and indent listings for maximum readability | Self-test mode for printhead, variable line spacing, international fonts including Japanese Scandinavian | Accepts A4 cut sheets, self-test mode for print head, variable line spacing, international fonts including French and German. Can also accept ink ribbons |





#### ALPHACOM 32

Dean Electronics,  
Glendale Park,  
Fernbank Road, Ascot, Berks.

When it comes down to performance, the Alphacom 32 is simply a souped-up ZX Printer. It will LPRINT, LLIST and COPY in exactly the same 32-column format and nothing else. It won't recognize any of the standard Epson control characters which alter the print width, font style or anything else. And you won't get the graphics commands in any other form than the COPY mode. It even prints a question mark if you send it a line feed code! For my money, this makes it the least useful of the four printers.

I tested the blue thermal paper (though you can get black) and found it easier to read than a ZX printout, but the print quality was about the same. The printer also kicked up a bit of a racket — there was a constant grinding of the powerful, geared motor throughout the printing cycle.

The machine has a similar footprint to the Spectrum. There's a through connector for other peripherals but the thick connecting cable puts pressure on the power input jack so you can't tell whether it's on or not — it uses non-latching membrane one-off switches and there's no LED indication. The plus is that it's a plug-in-and-go printer, so no software setting-up is required.

#### FLOYD 40

Shive Instruments Ltd, 153  
Merrion Road, Ballsbridge,  
Dublin 4.

Nice software, shame about the case! This is the tattiest looking of the four, but it's got some pretty nice facilities.

I had to repair the thing before I could use it, as the printhead/motor mechanism is secured internally by three drops of glue — not such a great idea for goods entrusted to our postal service! To be fair though it was a pre-production model.

This is another plug-in ZX Printer replacement with a through connector, but this one draws its power from the Sinclair supply.

It offers several formatting modes which use embedded control codes flagged by ! Automatic word-wrapping is performed on printed text to make your paragraphs neat. The word-wrap also takes into account that characters may be printed double-width. You can also have double height and inverse characters or any combination of the three that takes your fancy.

If you're printing out listings, you'll get them with right-justified line numbers, and everything else is indented and word-wrapped. All of which makes for very readable listings. Graphics mode prints everything just like the ZX Printer. You'll have to get used to the slight inconvenience of the embedded codes, but the results are worth it.

#### EPSON P-40

Epson UK Ltd, Dorland House,  
388 High Road, Wembley,  
Middlesex, HA9 6UH.

This is a smart, simply-styled pocket-size printer offering many of the facilities of its bigger brothers in the Epson dot-matrix range. Enlarged, emphasised, condensed and normal characters are software-selectable using the standard control codes. You're also offered Epson bit-image graphics and several international fonts.

This is certainly the neatest of the four printers. It's fractionally smaller than a Spectrum, and I reckon you could fit about eight P-40s into one of the standard 80-column dot-matrix printer. The P-40 can print 40 or 80 column text on its 110 mm (4") wide paper roll. Easily accessible DIL switches let you select things like default column size, auto line feed, and RS-232C data format and baud rate if you're using that interface. In fact these simply poke through the back of the case so you don't need a screwdriver.

For its size, the P-40 makes a bit of a din. It runs off an internal NiCad battery.

If you go for this printer, I'd recommend getting the Centronics version (plus a suitable interface like the ZX Lprint III) rather than the RS-232C version. Epson use non-standard RS-232C connectors to save space and we had great difficulty in connecting up the equipment.

#### BROTHER HR-5

Shelby Street, Cruide Bridge,  
Audenshaw, Manchester M34  
5JD.

This is the largest of the four printers but it's also the most versatile. For starters you get the choice of using either thermal or ordinary paper, and there's no problem with fitting in the ribbon cartridge. The HR-5 senses automatically which type of printing's required.

Second, it's the only one of the printers to accept A4 cut sheets, so it's ideal for letters and the like. It offers all the printing options of the Epson, plus its own internal graphics character set. The actual printing is performed fairly quietly, and with the thermal paper, I obtained a very contrasty, high-quality printout. Beware however — the thermal paper only works one way round, and the two sides are almost identical.

Print quality is just as good if you're using the ribbon on ordinary paper, though because there's no striking action, smooth copier-type paper is best.

You can also use roll paper with the clip-on roll holder that comes as an accessory. Battery operating is possible, but at 1 amp they peg out pretty quickly — I fitted a new set and got a low battery warning after printing one page! So use the mains adapter.

I'd certainly recommend this one as the top-of-the-range choice.



### TT-S: SPECTRUM TOOLKIT £7.95

For the 16 or 48K Spectrum. 5 programmer's programs on one cassette.

- ★ **GAMMA:** A relocatable, microdrive compatible BASIC extension giving improved editing plus 10 new keywords including intelligent RENUMBER and MOVE as well as DELETE, FIND, TRACE, FREE, AUTO and VARIABLES.
- ★ **SCREEN:** A High resolution drawing utility.
- ★ **UDG:** A powerful aid to creating user-defined graphics characters.
- ★ **TAPE:** Reads valuable information from tape file headers.
- ★ **RAM:** A thorough memory test program.

(A Dutch version of TT-S is available from AMB Software)

### HI-T: SPECTRUM SCREEN ENHANCER £5.95

Gives the option of using 32 rows of 64 characters each on the screen of a 16 or 48K Spectrum, with text 'windows', superscripts & subscripts and INPUT AT any part of the screen. A fully relocatable microdrive compatible machine code program, integrated with the Spectrum's normal PRINT, INPUT and LIST commands. Invaluable for serious Spectrum users.

**BOOKS:** Exploring Spectrum Basic: ISBN 907892 03 5: £4.95  
Explorers Guide to the ZX81: ISBN 907892 02 7: £4.95

**ZXS SPEECH SYNTHESISER** for the Spectrum or ZX81: £24.99  
**ZXM 3-CHANNEL SOUND BOX** for the Spectrum or ZX81: £29.95

★ ★ ORDERS DESPATCHED WITHIN 48 HOURS OF RECEIPT ★ ★

Prices inclusive of VAT and U.K. P&P. Overseas customers add £1.50 per item for surface mail. Access/Visa accepted.



**TIMEDATA Ltd.**, Dept N  
16 Hemmells, Laindon, Essex SS15 6ED  
Tel: (0268) 418121



£8.50 INC VAT, P&P



£7.50 INC VAT, P&P

## SPECTRUM THE MACHINE CODE SYSTEM

- ★ "... one of the all too few jewels of Spectrum programming... deserves a place in every serious programmer's library" (Simon Springett—Popular Computing Weekly—June 1984)
- ★ "... the whole package is very friendly and easy to use... can be highly recommended for those who are just about to start programming in Machine Code." (Phil Holliday—Your Computer—May 1983)
- ★ Fully compatible with MICRODRIVES/NETWORK/RS232 (with interface 1) and most popular Centronics interfaces for 80 col. printout.

## AMSTRAD THE MACHINE CODE SYSTEM

- ★ Both programs in one package
- ★ Many NEW FEATURES
- ★ Compatible with CASSETTE and DISC

### AVAILABLE SHORTLY

- ★ Send S.A.E. for fully detailed leaflet
- ★ Available from many computer shops, or by FAST mail order by sending a cheque/PO. to—



Dept YS, Picturesque, 6 Corkscrew Hill, West Wickham, Kent BR4 9BB

## HISOFT High Quality Microcomputer Software

**FONT 464** is an easy-to-use program enabling you to design, edit, and save your own characters and graphics for simple use in BASIC programs. There are 6 pre-designed fonts and sophisticated printer-driving software which allows high-resolution screen dumps and letter writing on Epson compatibles or the DMP1.

**ULTRAKIT** is the most powerful interactive toolkit yet for ZX BASIC. All the features you will ever need:

AUTO BREAK COPY DELETE EDIT FIND GRAB HIDE INFORM JOIN KEY LOSE MOVE NUMBER ONERROR PUT QSEPARATE RAMTOP SUBSTITUTE TRACE UPDATE VARIABLES WARN CRUNCH1 CRUNCH2 REMKIL PACKER MAP UCASE LCASE CTIME ATIME ALARM PRINTER KMODE RESET and much more. It comes with a FREE tape header reader.

**DEV PAC** is a complete machine code development package. It is the second one that many people buy, because after the first one they know what to look for! The 'front panel' debugger is the only way to really see programs in action, and assembly from multiple source files is fast enough to satisfy its most demanding users - ourselves.

**Pascal** is a valuable educational and development tool as well as running typically 40 times faster than a BASIC equivalent. Our compiler is an almost full implementation which compiles direct to machine code (no slow P-codes). Multiple file inclusion allows very large programs to be compiled.

**C** combines high-level structuring with direct control over the machine, all at compiled speed. Our compiler is now available from good retailers, and has proved extremely popular. It supports all statement types (plus inline code) and over 40 operators; whilst char, int, unsigned and combinations using pointers, arrays, structures, unions, functions, and typedef are all allowed data types. External and static variables can have initializers, whilst auto variables support recursion. There are six preprocessor directives and over 60 library functions with a selective inclusion scheme.

**MON QL** is our latest product and our first on the QL: it was written by Andy Pennell, who has a great deal of experience on the QL. It is similar in style to the well-known MON 'front panel' in DEV PAC and includes additions like job control and multi-tasking support. It also catches system exceptions and includes fixes for QDOS.

Product Price Table

|                | Pascal<br>£ | DEV PAC<br>£      | C<br>£ | ULTRAKIT<br>£ | FONT 464<br>£ |
|----------------|-------------|-------------------|--------|---------------|---------------|
| ZX Spectrum    | 25-00       | 14-00             | 25-00  | 9-45          |               |
| Amstrad CPC484 | 29-95       | 21-95             |        |               | 7-95          |
| MSX            | 29-95       | 19-95             |        |               |               |
| CP/M-80        | 39-95       | 39-95             |        |               |               |
| Sharp          | 39-95       | 25-00             |        |               |               |
| Sinclair QL    |             | 19-95<br>(MON QL) |        |               |               |

All prices are for cassette versions (except CP/M and QL) and include VAT and p&p in the UK. Please contact us for export orders, disc formats or detailed technical information packs. All products are available by mail order; please send a cheque or Postal Order. Sorry, we do not accept credit cards.

## HISOFT

180 High Street North,  
Dunstable, Beds. LU6 1AT  
Telephone (0582) 694421



# FRANKIE GOT TO HOLLYWOOD

With help from electronic instruments.

JOIN THEM... with the help of Electronic Soundmaker & Computer Music Magazine.

ON  
SALE  
NOW

## FREE MUSIC SOFTWARE

JUNE ES&CM turns your Spectrum into a powerful musical sequencer: a high-spec, pro hardware/software package giving you complete control of up to 8 'MIDI' instruments. You don't have to be a musician to use it. You don't have to be an engineer to build it. And ALL the software you need is on our regular free tape.

## COMPUTERS IN MUSIC

ES&CM have got it taped - literally. Every month, THE leading electronic music mag brings you the people and products behind today's hits, in print, and on tape.

EVERY MONTH - 60 minutes of music, interviews, reviews - and software.

EVERY MONTH - Electronic Soundmaker & Computer Music



● IN PRINT, ON TAPE - A CRUCIAL COMBINATION



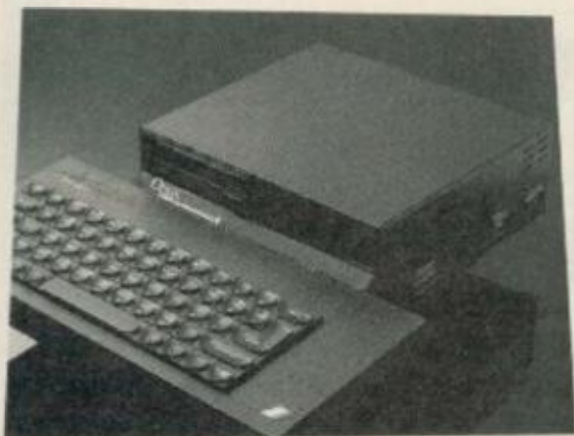

# DESERT ISLAND DISKS

Our competition castaway this month is ... you! But dwelling on our desert island could lead you to an important discovery — an Opus Discovery. Here's your chance to win one of five fantastic disk drives, worth a grand total of £1,000!



COMpetition



1

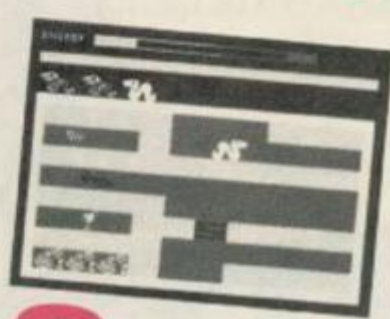

2

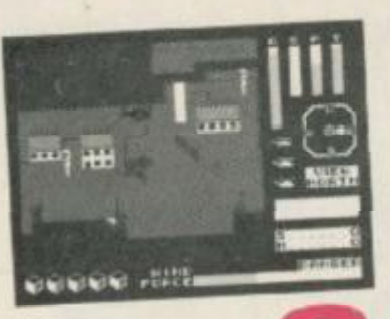

3

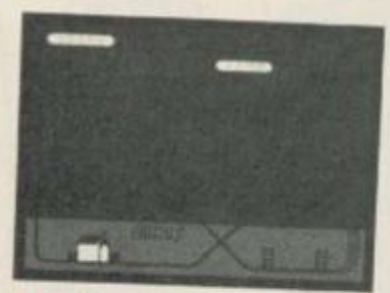

4

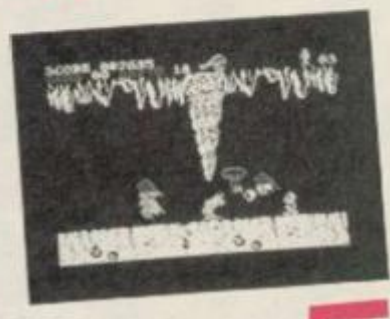

5

Suddenly, a storm breaks. You're tossed this way and that, until salvation comes and you're shipwrecked on the sun-soaked strand of a desert island. But for you there's no Bible, no Shakespeare, not even eight records and a gramophone.

All you've saved is one slightly soggy Specky and five salt-soaked pieces of software. Trouble is, all the inlay cards have become totally unreadable and only the screen shots survive. Your task is to match those shots with the name of the game as it appears on the cassette labels. Forget all that guff you've read about constructing a shelter, hunting for food and building fires for passing ships. They're not going to help you get your hands on this month's luxury item — a two hundred quid disk drive!

### RIDDLE OF THE SANDS

Take a look at the five screen shots opposite and match them up with the appropriate game description. If you think that description A goes with screen shot 3, then your answer will be A3. Couldn't be simpler, could it? And if you're still stuck, perhaps you should have a quick perusal of past issues of YS that you just happen to stumble upon on your palm-fringed beach. (*YS certainly reaches the parts other mags cannot reach!* Ed.) Once you've got them all sorted out, suggest a game you would take to a desert island if you were only allowed one. And then tell us why.

### MAGNUM OPUS

You'll have read about the Opus Discovery in last month's Frontlines (and if not, why not? Ed), but to recap here's the impressive list of its features. It uses 3 1/2" disks and has a joystick interface, a peripheral through connector, a parallel printer port, a monitor output and an on-board power supply. Best of all, it was designed specifically for the Spectrum so it slots directly into the back. Now that's not bad for £199.95 but it's truly amazing for free! Just think of all that memory and the new-found reliability.

So, stop playing sandcastles and start scribbling now. Bung your completed coupons in an envelope and send them to Opus Discovery Compo, Your Spectrum, 14 Rathbone Place, London W1P 1DE. And remember to put your winning combination of letters and numbers on the back of the envelope.

### OPUS RULES OK

Entries for the Opus Discovery Competition must be post-dated no later than 30th June 1985. Each entry form must have the combination of five letters and numbers and your own choice of desert island software. The letter/number combination should also be marked on the back of the envelope.

The Editor's decision is final and no correspondence will be entered into regarding this decision.

- A 'Chute down to rule this ever-green land.
- B Out of ocean, into jungle, me big monster!
- C Use sabre to battle off nasties.
- D Romantic encounter with creepie-crawlies.
- E Up, up and away — chop-chop!

I was all washed up until I discovered the following answers:

A..... B..... C..... D..... E.....

If I could choose to take only one piece of software to a desert island it would be:

Because .....

Name .....

Address .....

Postcode .....

Now don't bother putting this message in a bottle and floating it to us, just put it in the post pronto to Opus Discovery Compo, Your Spectrum, 14 Rathbone Place, London W1P 1DE.

### MAGAZINE HEALTH WARNING

If you think it's diskusting and diskraceful to desekrate your copy of YS, why not send a photocopy instead?



**NEW**

## TAPE COPIER 7

Yes it can be done! Make security BACK-UP COPIES OF THE MAJORITY of your SPECTRUM programs including HIGH SPEED loaders, and JERKY loaders with TC7. A good "clean" copy which will hopefully suit your system. Other methods have proved limited.

- ★ includes BAUD RATE (speed) measurer.
- ★ can save high speed/jerky parts in "normal" form for DRIVE transfer.
- ★ so many extra features we can't possibly list them here. Just try it and see. As the market leader we can't afford to let you down.

COST ONLY £6.50 (or £7.50 with MT6 - see below).

**NEW**

## MD1b/WD1b for TAPE TO DRIVE TRANSFER

You now have a CHEAP but FLEXIBLE means of transferring your programs with our information sheets and software (not limited to a small list). Get much satisfaction and learn at the same time. To transfer most programs to MICRO/WAFA/DISC drive you MUST have this program. It gives you the tools to convert programs so that they will run on your drive. Includes ability to cope with v.long programs, can split/chop bytes in one go, "VAL" creator, REMkill, make Visible, etc. etc. FULL manual with example transfers. (also need TC7 for latest programs).

MD1b (WD1b for disc or Wafadrive owners) costs a mere £6.99. EXTRA program to CONVENIENTLY transfer converted bytes directly to m/drive with many other features (e.g alter program names, stop programs, etc) buy MT6 at £3. (Wafadrive version is called WAFATAPE at £4).

**NEW LERM INFORMATION SHEETS**  
Gives you DETAILS required to transfer a selected number of the more difficult POPULAR programs. Sheet 1 now available at £2 plus SAE (mark letter L11).

**UPDATE SERVICE:** for latest version on your LERM product send old tape + large SAE to get a £2 REDUCTION. **OVERSEAS:** add £1 Europe, £2 others for each product. SAE for enquiries.

**ALL PROGRAMS CARRY OUR MONEY BACK GUARANTEE** (not updates)

LERM, DEPT YS, 10 BRUNSWICK GDNS,  
CORBY, NORTHANTS.

# YOUR SPECTRUM MODEM OFFER

Dial yourself up a great deal — save £££s on a Prism VTX 5000 modem!



Have you ever wanted to have a peek at Prestel, chat to friends on a Bulletin Board or access one of the big databases? You have. Then YS has some good news for you! Now you can save £££s on our special modem offer, exclusive to YS readers.

We're offering the Prism VTX 5000 modem at the exceptional price of £49.95, plus £3.95's worth of user software absolutely free. And that's not all — you'll also receive a free quarter's subscription to Micronet 800 and Viewfax. Purchase the complete package and a whole new world will immediately open up to you.

The VTX 5000 is a smart black box that'll sit neatly under your Speccy. And because it doesn't need its own power supply, there's only one lead between you and the outside world. The modem is BT approved and provides 1200/75 baud.

Even better, your new modem can save you money. Think of all that free software just waiting to be downloaded into your computer. And all for the cost of a local phone call.

As well as entertainment, you'll find all the information you could ever need right at your fingertips. Plus you can now go to the shops and the bank without setting foot outside the door. Whatever you want, it really is only a phone call away. But remember stocks are limited and at this price you'll never again buy a modem cheaper.

## THE VIKINGS ARE COMING!!!

SWESCOT are proud to announce that we will soon be releasing several top quality programmes on the international market, made by some of Sweden's most proficient programmers.

And best of all.....PRICES FROM £1.99  
Du som bor i Skandinavien och söker bra program till din hemdator.

### KONTAKTA OS!!!

Vi har det mesta som finns i denna tidning till *samma* laga priser som gäller i England. Dessutom far vi in alla nyheter *samtidigt* som de släpps i England.

OBS!!! Vid katalogbeställning v.g. medsänd 5: - Skr i frimärken för portot.

## SWESCOT

Box 213  
121 02 Johanneshov  
Sweden  
08/39 27 00 — 08/81 18 01

I want to tap the power of my telephone, so rush me my Prism VTX 5000 modem.

I enclose a cheque for £49.95 for each modem, made payable to **MODEM HOUSE** and I realise that this all time low price includes the user to user software worth £3.95.

Name .....

Address .....

.....

..... Postcode .....

Complete the coupon (or a photocopy of same) and send it with your cheque or Postal Order to **Modem House, Iolanthe Drive, Exeter, Devon EX4 9EA**. Please allow 28 days for delivery.



# SNAP CRACKLE POP!

If you thought all had gone quiet on YS MegaBasic, keep listening 'cos we're about to break the sound barrier. Prepare to have your ears pierced by L A Privett's program on the MegaBasic PLAY command.

By now you're probably a pretty efficient MegaBasic programmer. You've mastered Procedures, you're magic with the Sprite Handling commands and no window is closed to you. What d'you mean, no! Keep watching and all will be revealed in future issues. But this month it's the turn of the PLAY command. Do all the megaprograms you've created still lack a mega backing track? Up till now it's been hard work to PLAY.

The reason's clear — it can start to sound a bit silly trying to convey in words the sort of sounds your Spectrum's now capable of. What would you think if you read this in the manual? 'If you put the value 12 in the last parameter, you'll get a PHUTT sound — on the other hand a number 9 will make the sound PHIZZ...' Get the picture?

To get round the problem, here's a small program that'll demonstrate the possibilities of YS MegaBasic's PLAY

command in the privacy of your own home — and save the sub-editor from any untoward embarrassment!

Type the listing into your MegaBasic system, RUN the program and up will come a display showing the current parameters of the PLAY command. Use the up/down cursor keys to choose which value you wish to change and then increase or decrease it with the left and right cursor keys. When you're ready to playback the sound you've created, press the space bar and wait for the assault on your ear 'oles. The parameters you chose will also be displayed on screen.

If you want to use the sound again in one of your own programs, then jot down the figures and keep them safe for later use. The trick is to find a way of remembering exactly what sort of sound your Speccy produced — which could mean going back to the phutts and the phizzes. Oh well!

## SPRITE MAGIC

For all of you who haven't got megasprites sussed yet, here's a demo from Mike Leaman.

```
1 POKE 56894,255
```

Line 1 This line marks the end of the 'Sprite Info area'. You should use this at the start of every program that uses sprites.

```
10 CLEAR 44855: LET P=44856
```

Line 10 This line clears the space above ramtop for the image info

```
20 FOR S=0 TO 3
30 READ A,B,C,D
40 POKE P,A: POKE P+1,B: LET
P=P+2
50 FOR Z=1 TO 14: POKE P,C:
POKE P+1,D: LET P=P+2: NEXT Z
60 POKE P,A: POKE P+1,B: LET
P=P+2
65 FOR Z=0 TO 3: POKE P+Z,6:
NEXT Z: LET P=P+4
70 NEXT S
```

Lines 20-70 Set up the image info

```
75 POKE 56750,255
```

Line 75 Turns all sprites off

```
80 FOR Y=0 TO 7
```

Line 80 Use eight sprites

```
90 LET S=56750+18*Y
```

Line 90 Gets address of individual sprite info

```
95 IF Y=0 THEN GO TO 110
```

Line 95 Checks that first sprite isn't turned on

```
100 POKE S,1
```

Line 100 'OR' sprite onto screen and sets the printing mode

```
110 POKE S+1,115: POKE S+2,80
```

Line 110 Sets x and y start positions

```
120 POKE S+3,5-RND*10: POKE S
+4,5-RND*10
```

Line 120 Sets random x and y movement

```
130 POKE S+5,1: POKE S+7,4
```

Line 130 This line moves the sprite every interrupt, then tells the sprite routine that there are four images

```
140 POKE S+9,4: POKE S+15,6
```

Line 140 Changes image every four interrupts, then sets rub-out to yellow ink and black paper

```
145 POKE S+8,RND*3
```

Line 145 Starts each sprite at a random image

```
150 POKE S+11,56: POKE S+12,1
75
```

Line 150 Defines beginning of image data for each sprite

```
160 NEXT Y
```

Line 160 Loops back eight times

```
165 POKE 56750,1
```

Line 165 Turns all sprites on

```
170 LET S=56750+18*INT (RND*8
)
```

Line 170 Alters its direction randomly

```
180 POKE S+3,5-RND*10: POKE S
+4,5-RND*10
190 GO TO 170
```

Line 180 Loops back and repeat again

```
200 DATA 255,255,129,129,63,2
52,33,132,15,240,9,144,1,128,1
,128
```

Line 200 This is the data for image info

```
1000 REM PLAY EXPLORER
1010 REM BY L A PRIVETT
1020 REM MARCH 1985
1030 :
1040 PCLEAR
1050 SETSCREEN
1060 SETDISPLAY
1070 SETVALUE
1080 BOXIN
1090 SCANKEYS
1100 STOP
1110 :
1120 :
1130 :
```

Lines 1040-1100 These lines call the main procedures in the program.

```
2000 @SETSCREEN
2010 WINDOW_0,0,22,64
2020 PAPER 0
2030 INK 6
2040 BRIGHT 1
2050 OVER 0
2060 INVERSE 0
2070 MODE_2
2080 CLS
2090 DRAW 255,0
2100 DRAW 0,175
2110 DRAW -255,0
2120 DRAW 0,-175
2130 FONT_1
2140 LET A$="PLAY_EXPLORER"
2150 SPRINT_20,10,1,2,A$
2160 INK 3
2170 ENDPROC_SETSCREEN
2180 :
2190 :
2200 :
```

Lines 2000-2170 This is the SetScreen procedure which draws the screen display.

```
3000 @SETDISPLAY
3010 LET A$="A B C D E"
3020 LET B$="= = = = ="
3030 INK 5
3040 DOWN_5,8,A$
3050 DOWN_5,12,B$
3060 FONT_2
3070 SPRINT_10,150,2,2,"PLAY"
3080 PRINT AT 2,40:"USE CURSOR"
3090 PRINT AT 3,40:"KEYS TO "
3100 PRINT AT 4,40:"SELECT AND"
3110 PRINT AT 5,40:"CHANGE "
3120 INK 6
3130 PLOT 0,36
3140 DRAW 255,0
3150 INK 6
3160 PRINT AT 8,40:"SPACE FOR"
3170 PRINT AT 9,40:"PLAY "
3180 BEEP .1,0
3200 ENDPROC_SETDISPLAY
3210 :
3220 :
3230 :
```

Lines 3000-3200 This is the SetDisplay procedure that draws the information windows.

```
4000 @SETVALUE
4010 DIM M(5)
4020 DIM V(5)
4030 DIM F(5)
4040 FOR F=1 TO 5
4050 LET P(F)=3+F*2
4060 LET V(F)=0
4070 NEXT F
4080 RESTORE 4180
4090 FOR F=1 TO 5
4100 READ Q
4110 LET M(F)=Q
4120 PRINT AT 3+F*2,16;V(F)
4130 PRINT AT 3+F*2,24;M(F)
4140 NEXT F
4150 LET PRE=1
4160 LET POS=1
4180 DATA 1,255,255,255,255
4200 ENDPROC_SETVALUE
4210 :
4220 :
4230 :
```

Lines 4000-4200 The SetValue procedure initialises the main variables in the program.

```
5000 @BOXIN
5010 PLOT 20,60: DRAW 111,0
5020 DRAW 0,79: DRAW -111,0
5030 DRAW 0,-79
```



```

5040 PLOT 95,0: DRAW 0,36
5050 PLOT 95,19: DRAW 160,0
5060 MODE_1
5070 PRINT AT 18,26;"A" B";
5080 PRINT " C D";
5090 PRINT " E"
5100 INK 4
5110 PRINT AT 15,25;"MAX"
5120 PRINT AT 15,14;"ACTUAL"
5130 MODE_2
5140 INK 2
5150 PRINT AT 12,40;"D TO QUIT"
5160 INK 6
5170 PRINT AT 15,40;L.PRIVETT"
5200 ENDFROC_BOXIN
5210 :
5220 :
5230 :

```

Lines 5000-5200 The BoxIn procedure draws the display of the current parameters.

```

6000 @SCANKEYS
6010 LET Z#=""
6020 OVER 1
6030 PAPER 1
6040 INVERSE 1
6050 PRINT AT P(1),6;Z#
6060 REPEAT
6070 LET FINISH=0
6080 IF IN 63486=239 THEN LEFT
6090 IF IN 61438=251 THEN RIGHT
6100 IF IN 61438=247 THEN UP
6110 IF IN 61438=239 THEN DON
6120 IF IN 64510=254 THEN QUIT
6130 IF IN 32766=254 THEN NOISE
6150 BEEP ,005,-16
6160 UNTIL_FINISH
6200 ENDFROC_SCANKEYS
6210 :
6220 :
6230 :

```

Lines 6000-6200 The ScanKeys procedure reads the keyboard and then sends the program to other procedures in the program.

```

7000 @DON
7010 LET POS=POS+1

```

```

7020 IF POS>5 THEN LET POS=5
7030 POSITION
7040 ENDFROC_DON
7070 :
7080 :
7090 :
7100 @UP
7110 LET POS=POS-1
7120 IF POS<1 THEN LET POS=1
7130 POSITION
7140 ENDFROC_UP
7170 :
7180 :
7190 :
7200 @POSITION
7210 PRINT AT P(PRE),6;Z#
7220 PRINT AT P(POS),6;Z#
7230 LET PRE=POS
7240 ENDFROC_POSITION
7250 :
7260 :
7270 :
7300 @LEFT
7310 LET S=POS
7320 LET V(S)=V(S)-1
7330 IF V(S)<0 THEN LET V(S)=0
7340 OVER 0
7350 PRINT AT P(S),16;V(S);" "
7360 OVER 1
7370 ENDFROC_LEFT
7380 :
7390 :
7400 @RIGHT
7410 LET S=POS
7420 LET K=M(POS)
7430 LET V(S)=V(S)+1
7440 IF V(S)>K THEN LET V(S)=K
7450 OVER 0
7460 PRINT AT P(S),16;V(S);" "
7470 OVER 1
7480 ENDFROC_RIGHT
7490 :
7500 :
7510 :
8000 @QUIT
8010 LET FINISH=200
8020 PAPER 0

```

```

8030 INK 7
8040 OVER 0
8050 CLS
8060 ENDFROC_QUIT
8070 :
8080 :
8090 :
8100 @NOISE
8110 LET A=V(1); LET B=V(2)
8120 LET C=V(3); LET D=V(4)
8130 LET E=V(5);MODE_1
8140 OVER 0
8150 INK 7
8160 PAPER 0
8170 PRINT AT 20,26;A
8180 PRINT AT 20,32;B
8190 PRINT AT 20,38;C;" "
8200 PRINT AT 20,44;D;" "
8210 PRINT AT 20,54;E;" "
8220 MODE_2
8250 PAPER 1
8260 OVER 1
8270 INK 6
8280 PLAY A,B,C,D,E
8310 ENDFROC_NOISE

```

Lines 7000-8310 The remaining procedures move the cursor around and then play back the sound you've created.



Use the cursor keys to change the parameters shown on the screen — then press the Space bar to PLAY.

# ROMANTIC ROBOT present

## New! TRANS-EXPRESS 85.2

The only fully automatic and professional utility for transferring Spectrum programs from:

- ① CARTRIDGE to CARTRIDGE or DISC to DISC or WAFER to WAFER
- ② TAPE to CARTRIDGE or DISC or WAFER
- ③ TAPE to TAPE
- ④ CARTRIDGE to TAPE

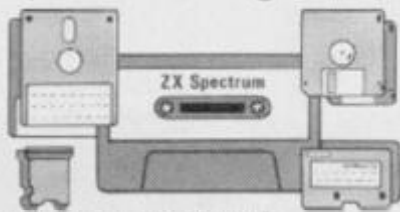

"An ingenious piece of software."  
 \*\*\*\*\* Features \*\*\*\*\* Performance \*\*\*\*\*  
 "A valuable utility for microdrive users." Sinclair User  
 "HIGHLY RECOMMENDED." PCN

NEW! Part ② new fully automatic: you just START/STOP the tape transfers, modifies, relocates, re-structures & helps to RUN also hyper, turbo headerless extra long (including 40K) parts, etc.  
 The best possible success ratio, the easiest & fastest in use.

## Wiggler



A novelty maze arcade game. Superb graphics and action. An extensive map, over 250 locations, full of features and creatures unseen as yet. New, funny, addictive, compelling.

Plus a bonus on side B: **'A WINNER.'** PCWeekly

## THE MOONS OF JUPITER

## New! MUSIC TYPEWRITER 85

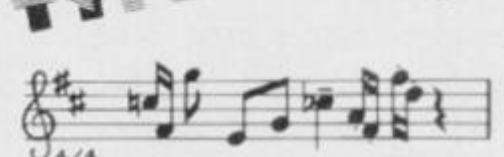

COMPLETE MUSIC SYSTEM FOR THE ZX SPECTRUM

"A very professional piece of programming, easy to use, excellent screen presentation, error trapping and helpful prompts." ZX Computing  
 "Extremely user friendly, lets you get started within minutes." Crax  
 "The notation has to be seen to be believed."  
 "Puts many expensive professional systems to shame." Your Spectrum  
 "Excellent aid to teaching the basics of music." Which Music? "Great fun." The Listener  
 "If you are interested in music and own a computer then get it." ZX Computing

NEW! Sheet music quality printout on dot matrix printers. NEW! Microdrive compatible  
 NEW SUPPLEMENT for £4.95 DATA CONVERTER to use music in your own programs. MICRODRIVER puts MT onto microdrives. NEW!

Please send SAE for details. Trade enquiries welcome. Deliveries normally by return.

I enclose a cheque/PO for £..... (European orders please add £1 overseas £2)

or debit my  No

Name..... Card expiry.....  
 Address.....  
 Signature..... Date.....

Please send me (tick as applicable) WRIGGLER £ 5.95   
 MUSIC TYPEWRITER £ 9.95  MT Supplement £ 4.95   
 TRANS-EXPRESS: part ②  or part ③ only £ 5.50   
 all parts on tape £ 9.95  or cartridge £ 14.95   
 ①+② on tape £ 7.50  or Rotronics wafer £ 12.95   
 Updates of TRANS-EXPRESS or MUSIC TYPEWRITER £ 3.50   
 TRANS-EXPRESS upgrades from tape to cartridge £ 6.95

ROMANTIC ROBOT 77 Dyne Road London NW6 7DR 24 hrs orders 01-625 9463



# BACK IN TOWN FOR A GREAT NEW SHOW!

# MICROFAIR

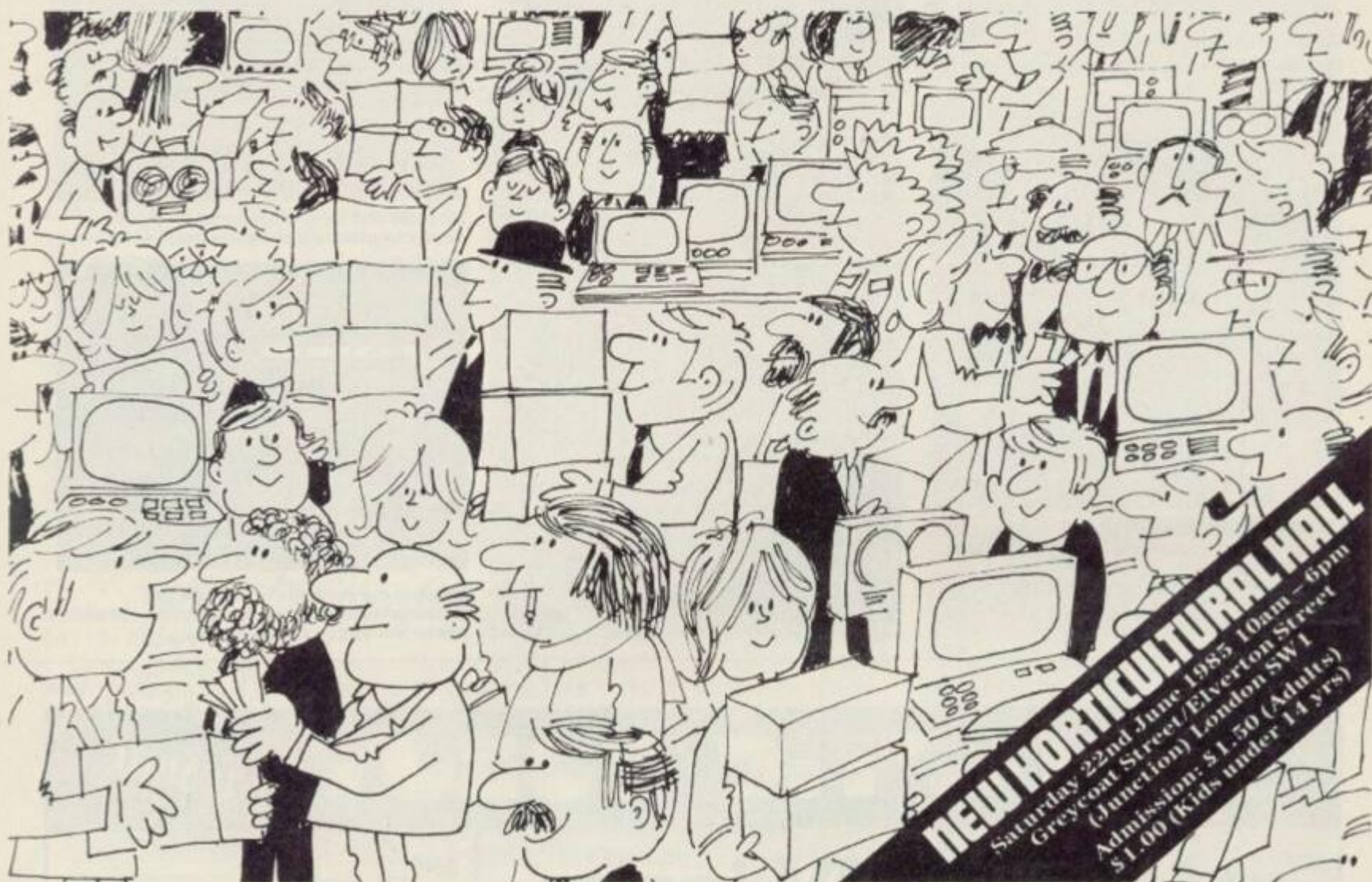

**NEW HORTICULTURAL HALL**  
 Saturday 22nd June 1985 10am - 6pm  
 Greycoat Street/Elverson Street  
 (Junction) London SW1  
 Admission: \$1.50 (Adults)  
 \$1.00 (Kids under 14 yrs)

**If you have a Sinclair Computer this is the show you can't afford to miss!**

The great day is June 22nd.

One day you won't forget if you own or use a Sinclair Computer.

**The Microfair is back in town.**

See everything that's new and original for The Spectrum, Spectrum+ and the fantastic QL.

If it's just launched you'll find it at the MICROFAIR. If you want advice you can talk face to face with the manufacturers. If you can't find it in the shops you'll probably find it at the MICROFAIR.

It's the user-friendly show that has out-lasted all the rest because everyone enjoys themselves . . . and you can always find a bargain!

Why not send today for cut-price advanced tickets.

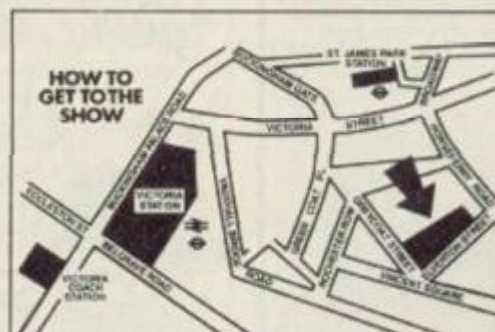

**Underground:** Nearest stations are Victoria, and St James's Park.  
**British Rail:** Victoria Station.  
**Bus Routes:** 11, 24, 29, 70, 76 and Red Arrow 507.  
**Road:** Signposted (RAC AA) Horticultural Halls.

## POST TODAY

Send to Mike Johnston (Organiser), Dept YS, ZX Microfairs, 71 Park Lane, London N17 0HG.

Please send me ..... Advance Tickets (Adult) @ £1.25

Please send me ..... Advance Tickets (Child under 14) @ 80p.

(Prices at the door are £1.50 and £1.00)

Name: \_\_\_\_\_

Address: \_\_\_\_\_



EXHIBITORS: CALL MIKE JOHNSTON ON 01-801 9172 FOR STAND AVAILABILITY.

Please include a stamped self-addressed envelope and make cheques/POs payable to ZX Microfair.



**YS**

Guilty's the cry as our joystick jurors send another game to the guillotine. Dare you hold a different opinion during their reign of terror?

**WARNING!**  
Just in case you find our scoring system too confusing, here's what it's all about. The score out of five is based on their experience of the game. But that's pretty subjective... so they also use the **HIT** and **MISS** system to indicate its potential as a commercial success.

# JOYSTICK JURY



Judge, jury and executioner, all rolled into one — *Dave Nicholls, Roger Willis and Ross Holman* — pass sentence on this month's selection of supreme Spectrum software.

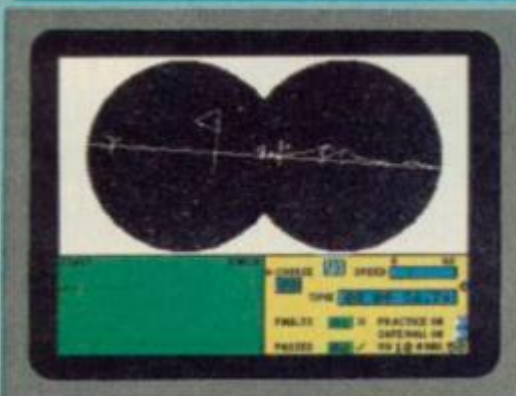

## SKI STAR 2000

Richard Shephard Software/£7.95

**Dave:** Here's one to play in the fridge for added realism! This game aims to do for

skiing what *Fighter Pilot* did for flying aircraft.

Graphically, it's got promise, giving you a goggle-eye view of the course with line drawn flags, pylons, and other hazards. But the best bit is its flexibility.

There are fifteen different courses and for each one you can choose the shape of your goggles, the amount of falling snow and so on.

In fact, all four of the courses can be completely altered using the built-in editor. It works on the Icon principle (like the Apple Macintosh), so you just move the cursor over the representation of the item you want and press fire. By pressing fire again, it will 'drop' the item into place.

There's even a waste bin for the unwanted articles.

As simulations go, this is a cracker, the editor is excellent and I had a lot of fun designing leg-breaking courses.

If you're into simulations, take a look, otherwise save your shillings and shell out on trip to the slopes **3/5**

**Roger:** Desperately peering through dirty goggles got me seriously piste off, or was it off the piste?

**1/5**

**Ross:** An original idea that doesn't come off. As a ski-ing simulator it's just too slow. This one's downhill all the way. **2/5**

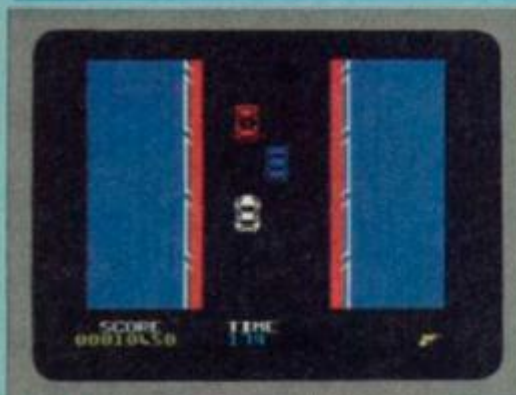
**HIT****MISS****MISS**

## SPY HUNTER

US Gold/£7.95

**Roger:** As the wrapper sez, this is hardly a game, and with the throwaway line like

that, US Gold aren't telling any lies. It's actually another driving number crossed with a liberal dose of shootiebangs. The action occurs on a scrolling map illustrating the road or waterways available for pursuit and destruction of a nasty collection including Road Lords, Switch Blades, Barrel Dumpers, Enforcers, Copters and yer actual Doctor Torpedo. (*Any relation to Dr. Findlay? Ed.*)

Apart from steering the 'vehicle' either on land or the blue-representing-wet stuff without crashing, the player is required to insert it back into a 'weapons van' at periodic intervals, for replenishment of ammunition, bacon sarnies or whatever. The unpleasanties which share the passing scenery have to be dealt with in

various terminal manners, or avoided altogether. Really, controlling this optimistically called 'turbo-charged race car/hydro speed boat' could be a satisfying business if one was only born yesterday. For those of us who've been around it stands out as an exercise not a little long in the tooth. As the man said, been there, done that before... **2/5**

**Ross:** The name's Bond, James Bond — and all I've got to say about this car classic is no, Doctor

No! **1/5**

**Dave:** This one's fast and it's tricky and if you're not careful it'll drive you up the wall. If only it actually got somewhere. **2/5**

**MISS****MISS****HIT**

## GRAND NATIONAL

Elite/£6.95

**Roger:** Offering an each-way bet on punter interest (aargh!), *Elite* has combined

most facets of Aintree's only claim to be anything other than a centre of unusually high unemployment. After all, isn't it better to train people to infest the bookie's rather than hang about on street corners?

The packaging has the essential form guide, which introduced rank outsiders to the opening screens of listed equestrian delights, whose odds change as racing history progresses. Besides the opportunity to spread basic stake money through the field, a player is also given the chance to take Spectrum reins in hand, riding a chosen nag.

The thunderous assault in Liverpoolian turf is represented by a sectionalised action profile of your trusty steed. This allows judgement of fearsome hedge

approaches, and an aerial 'plan' view of fences, jumps and all the other old donkeys thrashing about, to facilitate barging one's way through to the front... This is one game that ain't gonna be pulling a 48K milkfloat the day after. **5/5**

**Dave:** This is a pretty safe bet. It could be a touch faster in the race sequence but the horsey graphics are well observed and the betting side of it adds just the right amount of excitement. Go on, 'ave a flutter! **4/5**

**Ross:** Too slow for a true arcade and the graphics reminded me of those 'flick' books. If you don't go down the bookies, don't bother. **2/5**

**HIT****HIT****MISS**





# JOYSTICK JURY

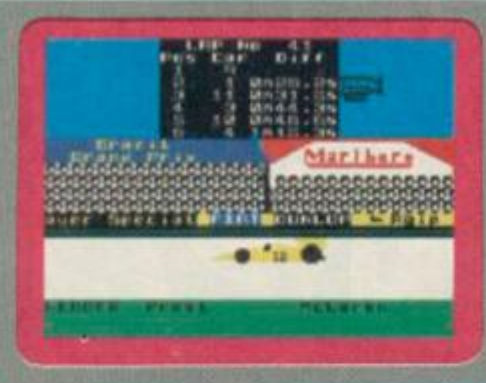

## FORMULA ONE

CRL/£7.95

**Ross:** Arcade addicts expecting all the thrills 'n' spills of the race track, read no further. This is a management game.

You're in control of a Formula One racing car team for a complete season, with the aim of winning the championship.

Before the season starts you choose your sponsor who will generously dish out large dollops of cash to spend on the little necessities of life, like drivers and cars. The drivers are all listed according to their price tags, with the top notch names like Prost, Piquet and Lauda fetching fortunes of £150,000. Then you have to get your team in race trim which means splashing out more money on car engines and pit crew.

On the big day you just have to make the critical tyre choice according to the weather reports. There's no qualifying and you'll automatically be allotted a grid position. The race display shows a section

of the track, a time board and the stands at the start and finish line. And then they're off. The bottom two lines of the screen take the role of Murray Walker and James Hunt offering the low-down on the race. At the end of the race your sponsor will lash out more lolly.

This isn't quite the pits, but you'd have to be a Formula One fanatic to find it fascinating for long. **2/5**

**MISS**

**Roger:** A classic case of missing a creative gear makes sure that this game fails to get off my starting grid. **1/5**

**MISS**

**Dave:** I found it tricky getting started but once I'd got the hang of it, I hung around for a lap or two. **2/5**

**HIT**



## BRIAN JACKS SUPERSTAR CHALLENGE

Martech/£7.95

**Roger:** Real live physical exercise always

seemed silly to me but simulating it on Spectrum is even sillier. Prejudices apart, I can only imagine that such a combination of TV personality name-dropping and this collection of visually naff sporting fixtures is supposed to scoop up any leftovers from 'Decathlon' and its ilk.

Running, cycling, archery, footie, swimming and the dubious delights of squat thrusting (*pardon? Ed.*) are included, demanding a great deal of mindless and finger-cramping button or key repeat to get our boy elbowing Brian from the podium.

Keyboard users had better be still in the protective shadow of Sir Clive's warranty because they're likely to need it. Sinclair has heard of circuit and membrane faults

but sporting injuries are worth a try ... Quite honestly, if you want to keep fit in an armchair there are better ways than this athletic tosh. **0/5**

**MISS**

**Ross:** If you're not soon bored by bashing the keys or jerking the joystick, you'll tire of having to keep turning the tape to load each event. **2/5**

**HIT**

**Dave:** My joystick ran for cover when I showed it this — it needn't have worried, I only played it a couple of times before I got bored.

It says on the inlay card that Brian himself reckoned 'It had better be good'. I wonder if anyone's got the bottle to show it to him yet. **1/5**

**MISS**

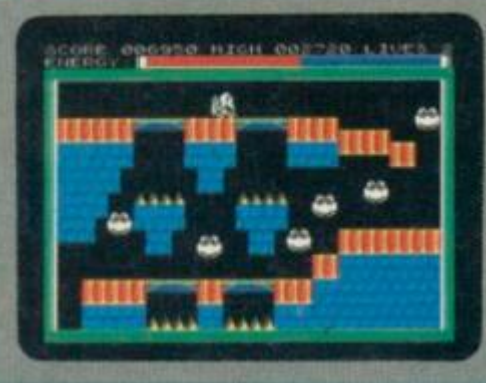

## BUG EYES

Icon/£5.95

**Ross:** Well, I'll be bug-eyed. Agent Starman's our hero in this game — but

haven't we been here before? Alien Space craft bent on the destruction of civilisation and eventual domination of the galaxy. You have to penetrate the ship and press on through its power generator. Sounds familiar? Like 99 per cent of all previous space-age shoot 'em ups!

The little space-suited chappy can move left or right and drop any distance without suffering noticeable brain damage. The ship's populated by a scruffy assortment of crushers, bug-eyed monsters and spiders, all of which prove harmful to prolonged existence if touched. You'll also have to negotiate bridges that appear and disappear and the old stand-by, moving platforms. At the top of the screen is an energy bar that gradually reduces until you

top it up by completing a screen. You can wave goodbye to another life if this reaches zero.

Each screen's a colourful concoction consisting of various blocks that form walkways and bouncing nasties that pose some tricky timing problems. No way is this original, but the screens take some thinking out if you're to get through. **3/5**

**MISS**

**Roger:** It takes more than ten screens of intergalactic body-swerving to get me bug-eyed. **2/5**

**MISS**

**Dave:** A pretty proficient, perambulating platform game with very smooth graphics. Why aren't there more screens though? **3/5**

**HIT**



## WORLD SERIES BASEBALL

Imagine/£6.95

**Dave:** Imagine is alive and well and living on its former glory.

*World Series Baseball* is another sport

simulation, just as the sport is just a Yankie simulation of rounders! You have to pit your team and your wits against another player or the computer. To help you the screen shows a commentators eye view of the field with a large 'video screen' at the back displaying close ups of the Pitcher and the Batter during the game, and of the Cheerleaders between innings! (*whoopie! Ed.*) The teams alternate between batting and fielding and as far as I could tell, all of the standard rules of baseball are observed.

When batting you have control over one player at a time while the rest of your team looks after itself and runs about a bit to create the illusion of something happening. When fielding you control the player that the computer decides is in the

best position to retrieve the ball (just like *Match Day*). You've also got some control over the flow of the game by changing the angle the ball is pitched at and the timing - of the batter.

Still the reasonable graphics, and the slight strategic element, didn't take the game close to a home run for me. **2/5**

**MISS**

**Roger:** Smart sporting scenery almost makes up for lack of content, but it looks better than it plays. **3/5**

**HIT**

**Ross:** The big video screen at the back's a real stunner. But as I never got a man passed second base, I'm gonna need some more practice before the Detroit Daredevils come a knocking. **3/5**

**HIT**





**MICRO CHALLENGE . . .**  
**the first computer-age**  
**puzzle magazine**

**No, not another**  
**computing magazine.**

**Micro Challenge is unique. Colourful and exciting,**  
**it's packed with intriguing puzzles — and prize competitions**  
**— devised specifically for microcomputer owners.**



*This is an example of one of the many types of puzzle to be found in Micro Challenge — but it's also your chance to win a superb JVC portable colour television with remote control. Solve the problem, using skill, judgement and your own micro, then send the solution, on one of the prize puzzle entry forms from the May/June issues of Micro Challenge, to the address given in the magazine, marking the coupon AP1. (A proper form must be used; no photocopies or facsimiles are permitted). The competition closes first post on June 17, 1985, and the first correct entry opened wins the prize.*

## TRIANGLE TANGLE

*Brush up on your geometry to unravel the answer.*

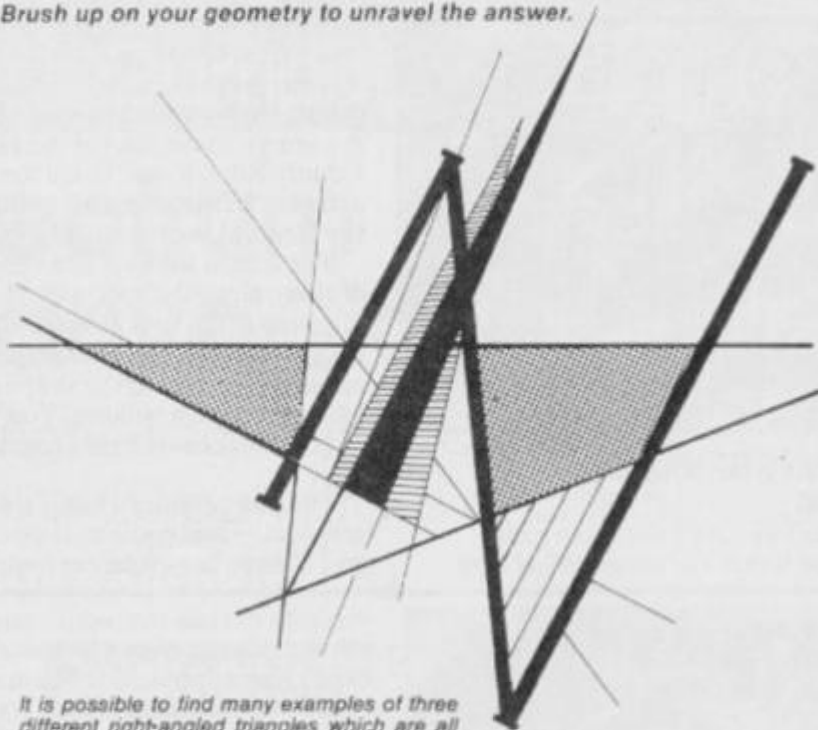

*It is possible to find many examples of three different right-angled triangles which are all equal in area. Can you, however, find three such triangles for which every side is a whole number of units (an integer)? Try to devise a program to find the trio with the smallest possible area.*

**Moving at the speed of light you could still snap up our fabulous launch issue. Order a regular copy from your newsagent now. Details of subscriptions or postal deliveries contact:**  
**MICRO CHALLENGE**  
**Somers House, Linkfield Corner, Redhill, Surrey**  
**RH1 1BB**





# JOYSTICK JURY

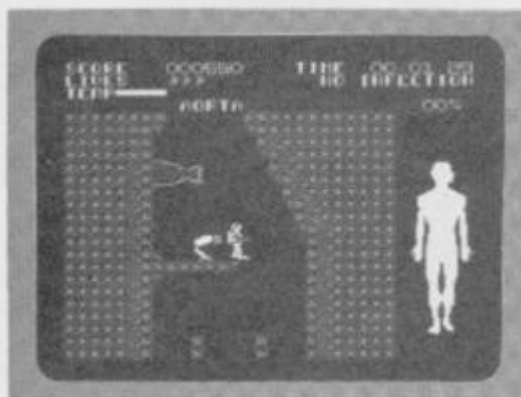

## FANTASTIC VOYAGE

Quicksilver/£6.95

**Ross:** Like the film of the same name, this game finds you inside the body of a scientist in a last-ditch bid to stop him

kicking the bucket. Unfortunately the minaturisation process hasn't worked too well and your submarine-come-surgical scalpel has broken up and been scattered through the body. Your task is to re-assemble the sub and to keep your host alive.

You swim around the tubes and intestines wearing a wet suit and flippers, and carrying a laser — it gives a whole new meaning to a life-saving swim. The laser is vital as it's your only means of knocking-out the body's defence system. Also watch out for your own energy levels — if they drop too low, you become invisible and you'll have to find some red blood cells to replenish them. The host body is also under attack from infections that cause a rise in temperature and

eventual death if not treated rapidly, so be prepared to launch a rush rescue mission to blast the anti-bodies.

You'll also have to deal with growths, cholesterol blockages and viruses — it's enough to persuade you to chuck it all up now! Biology was never this boring, so don't go forking out an arm and a leg on this one. Rigamortis set in far too swiftly. **2/5**

**Roger:** Slithering round inside somebody's vitals looking for diseased tissue and scrap metal ain't my idea of fun ... **2/5**

**Dave:** Is this the first game to be written in body language? Shame that it's missing a couple of things that were in the film —

Raquel Welch, for example! **2/5**

**MISS**

**MISS**

**HIT**



## DRAGONTORC

Hewson/£7.95

**Ross:** Here it is, the follow-up to *Avalon*, featuring the same graphical furniture but

with a finer back-drop. Your quest is to seek out the five crowns of Britain and free Merlyn from the evil grip of Morag the Shapeshifter (*and don't try saying that when you've had a few! Ed.*)

The game comes with a map of the Realms of *Dragontorc* and a potted history of the story so far. You control the familiar figure of Morac by choosing the move spell from the scroll displayed at the bottom of the screen.

You've also got two other spells at the start — the servant spell does all the graft by providing you with a hard-working sprite that runs errands and fights, and there's also the Bane spell. That's much more mysterious and I'll leave it to you to discover how to use it!

There are about 256 locations to explore and over 80 characters — or so it says here.

I didn't get that far and I reckon it'll take quite a while for someone to crack it.

If you liked *Avalon*, you'll love this. I found both of them to be dreary dark-age dramas — not a patch on Dallas. **3/5**

**Dave:** It's an improvement over the original but I still rate this as a triumph of programming over playability. **2/5**

**Roger:** Ding-dong! It's *Avalon* calling again ... More of the same and just as satisfying. **4/5**

**HIT**

**HIT**

**HIT**



## THE DUKES OF HAZARD

Elite/£6.95

**Dave:** Was I looking forward to a nice dodge and weave car chase! What I got

was a great let-down.

Your task is to motor the General Lee (that's your wheels, not some big wheel in the army), to the start of the Hazzard County Road Race. There the Duke Boys aim to win first prize and avoid handing the General over to Boss Hogg.

The screen shows a side view of the cars cruising along the road with the mountains scrolling in the background. Chasing you is the Sheriff as well as a couple of airborne enemies in the shape of a helicopter and a balloon. You've also got to play chicken with cars coming the other way.

The programmer's had a crack at 3D graphics — and come a cropper — when you change lines your car appears to move

backwards and forward but the collision detection just can't handle it. And what wally chose the controls? You have to hit a key repeatedly (or wiggle the joystick) just to accelerate, which is a complete waste of time and energy. This game's an OK sort of idea with some decent graphics — it's just a shame about how

it was done. **1/5**

**Ross:** New graphics and a new name don't add up to a new game. And you'd think they'd have done a better job on the collision detection in a car-chase game. **1/5**

**Roger:** Lacks the precision of control necessary for exciting crash-bang-wallop driving stuff and it's just not funny enough. **2/5**

**HIT**

**MISS**

**MISS**

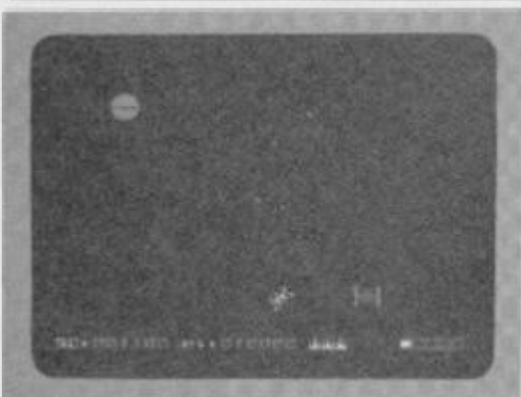

## DEATH STAR INTERCEPTOR

System 3 Software/£7.95

**Ross:** Yep, you guessed — it's a *Star Wars* rip-off with solid colour graphics. It's even got the *Star Wars* theme tune. I won't tire

you with the tale that accompanies the game — it's the usual old tosh about the Death Star approaching Earth in order to destroy it. You must launch your Starfighter with the aim of confronting the enemy.

The game's split into three stages, the first launching sequence requires little skill and less strategy and soon becomes very boring. The snippet of software speech saying 'prepare to launch' sounds like the speaker had a nasty dose of flu when it was recorded. The second stage, out in space, shows your fighter desperately trying to avoid destruction from the barrage of enemy fighters constantly bearing down on you. Rather than battle it out with them it's best to avoid the bulk of them and shoot only those you can't avoid. Quite a

doddle as there's a 'dead zone' where you can sit it out in safety.

The final stage in the trench is not pulse-quickening either, and the final explosion's just a flash in the border. So much for saving civilization. I'd heard good reports of this game but it's arrived with a whimper, not a bang. **2/5**

**Roger:** Three stages of Star-Yawns didn't keep me awake long enough, despite tolerable speed and shootiebang quotient. **1/5**

**Dave:** Zap Ping Whoosh Yawn! another fast, almost 3D shoot 'em up with reasonable graphics, the usual storyline and a boredom factor of 10! **1/5**

**MISS**

**MISS**

**MISS**



SHARDS

# THE FAMILY FAVOURITES



**MYSTERY OF THE JAVA STAR**  
From SHARDS software  
ELECTRON, BBC DRAGON/TANDY COCO  
CBM 64/AMSTRAD (March)  
£7.95

**FOUR PART EDUCATIONAL ADVENTURE**

"Shards are now setting a standard for this type of adventure."  
Micro Adventurer.  
"An excellent educational program with something of interest to kids of all ages - including big ones".  
Electron User.



**PETTIGREW CHRONICLES**  
SPECTRUM 48K,  
CBM 64  
£9.95  
EPIC  
FOUR PART  
FAMILY  
ADVENTURE.

"I liked this mixture of puzzles, games and text adventure and felt it represented good value for money."  
HCW.  
"An entertaining release... a nice package to play together after Christmas lunch". PCW.



**EMPIRE**  
From SHARDS Software  
there is no hiding place...  
CBM 64,  
ELECTRON, BBC  
DRAGON/TANDY COCO  
£6.95  
COLOURFUL GAME OF  
WORLDWIDE  
STRATEGY.

"I thoroughly enjoyed this game... the graphics are excellent".  
(Electron) HCW  
"Not a bad attempt at simple war-gaming... a good game".  
(CBM64) HCW.



**GALILEE**  
SPECTRUM 48K  
£5.75

**EXTENSIVE ILLUSTRATED TEXT ADVENTURE.**

"An intriguing adventure, original in many ways... should appeal to most adventurers."  
PCN.



**JERICO ROAD**  
From SHARDS software  
SPECTRUM 48K  
BBC/ELECTRON (March)  
£5.75

**FULL FEATURED EDUCATIONAL ADVENTURE.**

"A gentle, original and enjoyable adventure".  
Sinclair User.  
"The program is enjoyable and interesting because of its historical accuracy".  
PCN.

**AVAILABLE NOW FROM  
SELECTED BRANCHES OF BOOTS  
AND ALL GOOD STOCKISTS  
or by mail order, using the coupon.**

To: SHARDS SOFTWARE, 189 ETON ROAD, ILFORD, ESSEX, IG1 2UQ (phone 01-514 4871)

Please send me a copy of (please tick)  Pettigrew Chronicles   
 Empire  Galilee  Jericho Road  Mystery of the Java Star   
 My computer is \_\_\_\_\_  
 Name \_\_\_\_\_  
 Address \_\_\_\_\_

Please debit my ACCESS/VISA Account, A/C No. \_\_\_\_\_  
 (or phone 01-514 4871 to save time) I enclose a cheque/PO remittance for £ \_\_\_\_\_ made payable to SHARDS SOFTWARE.  
 Signed \_\_\_\_\_

## TRANSFORM LTD. Computer Accessories

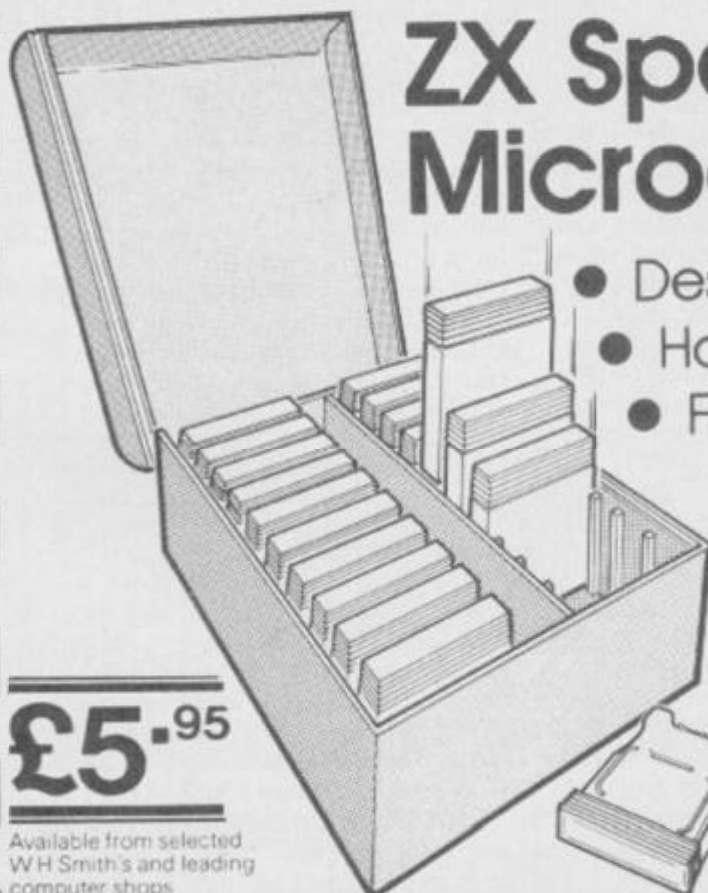

### ZX Spectrum and QL Microdrive Storage Box

- Designed to match QL and Spectrum
- Holds 20 cartridges and index cards
- Fully interlocking

**Available Now**

|                                  |        |
|----------------------------------|--------|
| QL Centronics Interface .....    | £39.95 |
| QL Dust Cover .....              | £5.00  |
| QL RS 232 Lead .....             | £10.00 |
| Spectrum Monitor Connector ..... | £11.50 |

• We also supply printers, monitors, labels, ribbon and listing paper.

**£5.95**

Available from selected WH Smith's and leading computer shops

**TRANSFORM LTD. (Dept. YS) 089 283 4783**  
 'Swatlands', Lucks Lane, Paddock Wood, Kent TN12 6QL.







# JOYSTICK JURY



## FINDERS KEEPERS

Mastertronic/£1.99

**Dave:** Judging by the standards of the early cheapo games you would've been forgiven for thinking someone had misheard

'budget' for 'bodge-it'.

This game certainly changes all that. There's nothing particularly new about it — we've seen platform games before (*just a few! Ed*) but there are a number of unusual differences.

For a start, not all the playing area is divided into rooms — there are some rather nice scrolling mazes tucked away in there.

Then there's an extra element to the game that really makes it. Some of the objects that you'll find combine to make a third, and you can then start bartering for other bits with the Castle traders.

The whole point of all this hunting and haggling is that you have been sent by the king to find a birthday present for his daughter.

The 'finders keepers' of the title just means that once you've nabbed the treasure, you can stash it away for yourself. It's a shame we're not informed of the king's reaction to this bit of private enterprise.

Fortunately, the plot ain't that important so you're not likely to lose your head. So, if you find it, keep it! **5/5**

**Roger:** I'd rather have kept the king's daughter than her birthday prezzies but hopping about to cop the loot was worth it anyway. **4/5**

**Ross:** A colourful, well presented game. Searching for treasure gives that bit extra to life above the competition — and at this price, it deserves

to be a ... **4/5**

**HIT**

**HIT**

**HIT**

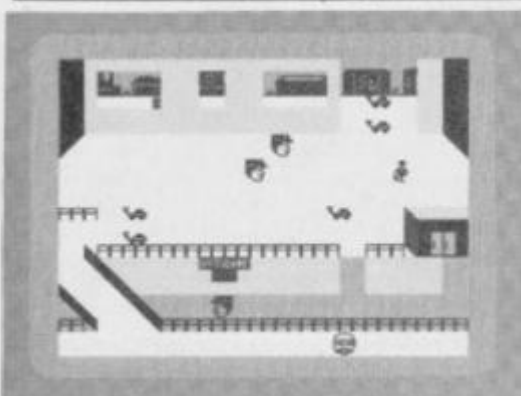

## A DAY IN THE LIFE

Micromega/£6.95

**Dave:** At last, good old Uncle Clive has finally received the recognition he

deserves. Today's the day he has to toddle off to Buck House to collect his gong as a Dame Commander of the British Empire (*bet he's chuffed. Ed.*) On the way, he's got to cope with all the aggro of commuting, like avoiding the British Rail staff (though I always thought finding them was the tricky bit). Along the way he's also got to eat, drink and be merry.

Using the keyboard or joystick you have to control Clive — or rather his head. Now we all know he's a brainy bloke, or he wouldn't have invented the Speccy, but only showing his bonce is a bit bad! It's up to you to manoeuvre his noddle around the numerous screens collecting the booty in the correct order.

The rest of the graphics are OK I

suppose, but the game gets a trifle tedious because of Clive's finicky ways. He just won't do what you want unless he's in exactly the right places. A slight miscalculation and you've lost a life as well as his body. A good 'cheapie' game being sold at full price! **2/5**

**Roger:** This could have been a satirical savaging of Sir Clive or it could have been a good game. It's neither. **1/5**

**Ross:** A multi-screen dodge and run game that traded on a guest appearance by Uncle Clive. It kept me awake for an hour or two, but I've had better days. **3/5**

**MISS**

**MISS**

**MISS**

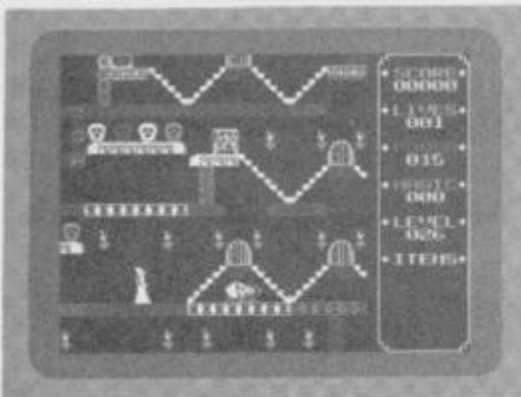

## MIGHTY MAGUS

Quicksilva/£6.95

**Roger:** With a name like a make of German articulated lorry, a chap could almost hope

for a new set of platform imagery but it's not to be found here. Sorcery is something we appear to be stuck with. At least this reel of software mystics is competently assembled.

The plot consists of negotiating our wizard-clone hero through thirty scrolling levels of the 'Rising Sun Temple', searching chests and scrabbling through interesting piles of garbage like a folkloric tinker. Spell-casting and fight options are available for defence and advancement as the quest for Fraugy The Fierce continues up, down and across a magical minefield of behaviourally unsporting geography. Traps and nasty surprises abound, whilst witty graphical images portray temporary concussion or funerals faster than the

Co-op's cheapest, upon loss of life. Originality is not one of the Magus's strongest character traits but it kept me out of the pub — for a while at least. **3/5**

**Ross:** There's more sense of adventure than usual in this arcade/adventure, but there's little else to recommend it. And why spoil it with the unpredictable magic squares and the random generation of the playing area? Mighty it's not! **2/5**

**Dave:** Wot, no joystick option? It's not exactly magic, but the randomly designed playing area makes it much more of a challenge, so even ace arcaders should take some time to crack it. **2/5**

**HIT**

**MISS**

**HIT**



**STOP PRESS!**

Minder, the new game from dk'Tronics arrived too late to go in Joystick Jury — that or someone's slipped a few sovs to our jurors.

"Ere, Tel, I've just stumbled on a great little earner."

"Wot is it now, Arfur? Is it bent?"

"Bent? Me? Course it's not bent. I've

just done a deal with this computer company."

"You haven't bought any a them Commodore 64s 'ave you?"

"What d'you take me for, Terry? No-one's that stupid! No, they want to write a computer game about us. All we 'ave to do is go round a few of the old haunts, you know, like the Winchester Club and my lock-up and do a few deals with some of the lads. Strike up bargains just as if we was doing 'em. I'll just be buying in some liquidated or fire damaged stock, all good stuff mind, and you go round collecting and delivering it."

"I knew there was some sort a catch."

"You'll get your cut. Money's all you ever think about, Terry. You're

becoming very materialistic, if I might say so!"

"That's choice coming from you, Arfur."

"As I was saying, you pick 'em up, and I sell 'em again — at a heart-breakingly small profit, of course. Just to see how much I can clock up in two weeks. All the blokes'll appear — in little boxes round the screen and we can talk to them just as if they was there — Dave from the Winchester, Sargeant Chisholm ..."

"You never said nothing about the Ol' Bill. If there's gonna be rozzers around you can count me out."

"We can handle them, Terry, We're onto a real winner 'ere and it costs less than a pair of Lady Godivas! Trust me ..."



OUT NOW ON CASSETTE AND DISK

THE FORCES OF LIGHT & DARK BATTLE IT OUT IN

# ARCHON

THE ULTIMATE ACTION & STRATEGY PROGRAM FOR YOUR CBM 64

**NOW**  
AVAILABLE ON  
SPECTRUM 48K  
AMSTRAD CPC464  
ATARI 600/800XL  
(CASSETTE & DISK)  
including FREE  
ENAMEL METAL BADGE  
OFFER



ARCHON is brilliant. There's something in it for all games addicts; arcade, adventure and strategy are all here. My only complaint is that it's best played against a human opponent – the computer's just too good and you can't give it a handicap.

**Bryan Skinner**  
*Personal Computer News*



INCLUDES SPECIAL DISCOUNT VOUCHER

PERSONAL Computer HIT!

- Features**
- Play the computer or a friend
  - Computer player gets tougher as you do
  - 64 Battle combinations
  - Separate battleground screen
  - Medieval pieces like the wizard and the sorceress – magic spells and a board that changes as you play
  - Deluxe boxed package includes full instruction and hints manual
  - Joystick controlled \*

\*and/or keyboard control (Spectrum & Amstrad versions)

AVAILABLE FROM ALL GOOD SOFTWARE RETAILERS - IF IT'S NOT THERE, PLEASE ORDER IT

ariola

HIGH PERFORMANCE PROGRA







# » INPUT OUTPUT

McKeown, 17 Brae Hill Parade, Belfast, BT14 8FR.

■ £15 for an Alphacom 32 printer. Will also give many games. Tel. (0606) 45859 and ask for Andy.

■ Required issue 2 of YS. Will pay £1.50. Tel. Walsall 612862 and ask for Trev.

■ Interface 1, Microdrive and cartridges. Swap for 3 Spectrum books and 15 tapes including *Valhalla*, *Tasword 2* and *World Cup Football*. Tel. (0761) 413975 and ask for Ken.

■ Issue 7 of YS. Swap issues 1 & 2 for it. Also want *Hisoft's Assembler*. Will swap for *Pictaquest Assembler*. Tel. (0533) 364067 (4-6pm) and ask for Adrian.

■ Printer wanted. Swap for £100s worth of software. Most new titles, arcade, adventures and utilities. Tel. Tamworth 51321 and ask for Chris.

■ Issues 2 & 3 of YS. Will pay £6 inc p & p. Write to Jacob Minidor, 6a, Beer Ora Street, Ramat Gan, 52273, Israel.

■ Got *Valkyrie 17, TLL, Zip Zap, Booty, Lazerwar*. Will swap for *Currah MicroSpeech*. Tel. (0473) 82361 and ask for Ian.

■ Wanted MicroSlot. Will pay up to £7. Tel. Emsworth 6321 (pm) and ask for Paul.

■ Wanted ZX printer with paper in good working order. Will swap software or a CB rig with transformer. Tel. 041-334 9691 and ask for Maureen.

■ Could anyone with a working version of *EZ-code*, from *Spectrum Machine Language for the Absolute Beginner* by Melbourne House, contact me. Tel. (0247) 455678 (after 6pm) and ask for Keith.

■ Wanted POKES for *Tir Na Nog* and *Knights Lore*. Tel. 01-853 4817 and ask for Nick.

■ Specky basher requires YS issue 2. Pay £7 for excellent condition. Tel. 01-540 7894 and ask for Dave.

■ I want a printer, Alphacom or better. Swap for software, Kempston interface, Beep-Booster, Speech Synth. Write to A McNamara, Penns Hall Hotel, Penns Lane, Walmley, Sutton Coldfield.

■ Wanted, book or tape to teach word processing basic through a 16K ZX Spectrum. Will pay a fair rate or do swap. Tel. Leeds 740614 (5-7pm) and ask for Anne.

■ Hand held *Galaxy Invader* game and Pinball machine, both battery operated to swap for *Sabrewulf* and *River Raid*. Tel. (0734) 597202 (after 6pm) and ask for Trevor.

■ Interface 1 wanted. Will swap any 6 of: *Knights Lore*, *Underworld*, *JSW*, *Full Throttle*, *Psion*, *FLT-Sim*, *Code-Name Mat*, *The Pyramid* and *Reflections*. Tel. (0656) 750572 and ask for Kes.

■ Faulty ZX Spectrum wanted. Will pay a fair price. Also a faulty printer. Tel. (0669) 20565 (pm) and ask for T Brook.

■ Wanted; Tele-sound beep amplifier by Compusound. Must have fitting instructions for Specky. Tel. Hebburn 834400 (4.30-5.30pm) and ask for Nicholas.

■ VTX 5000 modem, QEL Teletext adaptor, printer interface (Kempston), software for William Stuart Systems 3-channel sound interface. Also a pen pal proficient in machine code. Tel. (0491) 571448 and ask for Adrian.

■ ZX printer & 5 rolls of paper. Will pay up to £25. Tel. (0425) 73666 and ask for I A Barker.

■ Issues 2, 3 & 7 of YS. Must be complete. Pay £3 each. Tel. Welton 61308 and ask for Simon.

## » CLUBS & EVENTS

■ Israel. We've opened a Sinclair club will be called Sinclub. It will deal with the Spectrum and the QL. Please write to Divon Lan, Dov Hoz 25, Herzlia B, Israel 46581.

■ West London Personal Computer Club now has its very own Sinclair section. If you have a Spectrum, QL or a C5 then you'll be then welcome! Tel. 01-991 1199 (evenings) and asks for Dave.

■ Adventure help! Send an sac for the clue you need. We have hundreds of clues. If we can't help we'll let you know. Also, any clues are welcome. It's free! Write to KW Douglas, Schoolhouse, Detmold Road, Upper Clapton, London E5 9NL.

## » MESSAGES

■ Help! I want to transfer my software to microdrive cartridges. Send info to Jason Allen, 14 Littleport Spur, Slough, Berks SL7 3JD.

■ Need help? Tips on *Valkyrie 17*. Please tel. 061-430 6834 (after 6pm) and ask for Andrew.

■ Spectrum owners: I would like to contact parents with young children (1-7 years). Please send details, all letters answered. Write to A. Close, 38 Homedale House, 3 Brunswick Road, Sutton Surrey, SM1 4DG.

■ *Dragon Fire!* A new zine created for micro adventures. Includes views, tips, reviews and much more! Only 50p (inc postage). Write to

Nick Walkland, 84 Kendal Road, Sheffield S6 4QH.

■ YS issue 1 to sell £4. Issue 2 with poster £4. Issue 3 - £3. Tel. Leeds 689526 (after 4pm) and ask for Daniel.

■ On-The-Rocks-Richard! I can help with your microdrive problem, but it's embarrassing my mother won't let me use the phone! Call me on (0851) 82219 and ask for Andrew.

■ I just want to say hello to all Specky owners in the Nicholson Institute, especially Peter, Big H, Moggy, Jim Macaulay etc from Andrew Edwards, Isle of Lewis.

## » PEN PALS

■ Pen pal wanted to help solve Adventure games. Over 18s please write if you can help! Write to Amanda Boldenston, 26 Warwick Close, Market Drayton, Shropshire TF9 1RQ.

■ Hisoft *Pascal* pen pal wanted to swap programs and tips. Anybody, any age, any other language. Write to Michael West, 48 Norman Street, Bingley, BD16 4JT.

■ My name is Chris and I would like anybody 13 years old to swap games, hints and tips. If you like writing, get your pens out and write to me, C. Moon, Prior Park Sch, Calcott Street, Cricklade, Wilts SN6 6BB.

■ I would like a pen pal preferably Scottish to share hints 'n' tips for the Spectrum. I am 12 years old. Write to Andrew Edwards, 22A Coll Back, Isle of Lewis, Scotland PA8 6UP.

■ Pen pal aged 13 wanted to give opinions on games, hints on POKES, etc. Write to Robert Howat, 45 Moss Dale, Heathball Dumfries, Scotland, DG1 3RG.

■ Wanted female pen pal about 16 years, interested in hacking, for male hunk (16 too). Just starting to get into computers. Write to Will Jordan, Wolfe, Dyrms, Dover, Kent.

■ Pen pal 10+. I have a large selection of Spectrum games and would like to swap hints, tips etc. Write to Alistair Don, 7 St. John's Close, Morton, Nr Bourne, Lincs, PE10 0NR.

■ Female pen pal, County Durham area, aged 14, interested in software. Write to Lee Woodhouse, 98 Woodland View, West Rainton, County Durham.

■ I would like a girl pen pal under 13, who has a 48K Specky. Interests include ponies, ballet, reading and farms. Will swap tapes. Tel. (0353) 777412 and ask for Felicity.

■ Hi, my name is Sean, and I'm 18. I love my Spectrum, good music and discos. I want a female pen pal with similar interests. Send photo if you wish. Write to Sean Rowe, 1 Rosewalk, Worthing, W. Sussex.

■ 16 year old pen pal wanted. Able to send software, hints and tips, etc. Please write to Anthony Burns, 60 Beardow Street, Lismore Height, NSW, Australia 2480.

■ I would like a pen pal to share computer hints and tips. Look forward to hearing from you! Write to Ying Wai Wu, 2 Auckland Road, Sparkbrook, Birmingham B11 1RH.

■ I am 12 years old and would like to swap software with a pen pal. Also swap hints on programming and hacking. Write to Matthew Lomas, 16 Delph Lane, Aughtoon, Nr. Ormskirk, Lancs. L39 5DZ.

■ I am 12 years old and would like to have a pen pal of the same age that likes hacking and game playing. Write to Gavin Keen, 8 Bayne Drive, Dingwall, Ross-shire, Scotland IV15 9UB.

■ Pen pal male/female wanted, about 18 years old. Into rock music, sci-fi and adventure games. Write to David Tiffany, 5 St. Lennoards Close, Upper Minoty, Malmesbury, Wilts. SN16 9QB.

■ I am 13 and would like a boy/girl pen pal of same age. Preferably a Microdrive owner to swap programs. Write to Keith Johnston, 3 Navar Court, Bangor, Co. Down, N. Ireland BT19 2PS.

■ Hello, I am 16, hobbies include computers, playing latest mega hits and drawing mad cartoons. Would like pen pals. Please write to Flout de Kok, Het Oostveld 9, 7907 GE, Hoogeveen, Holland.

■ Pen pal wanted to swap games, adventure hints etc. I am 14. Please write (including games list) to Andrew Young, 7 Weston Place, Prestwick, Ayrshire, Scotland, KA9 2ED.

■ Pen pal wanted to swap software and hints. I am 15 and play games at all hours! Write to Richard Peasey, 43 Post Mill Gardens, Woodbridge, Suffolk IP13 6UP.

■ Boy aged 13, likes programming, wants foreign pen pal of same age, preferably Israeli to swap ideas. Write to Steven Fisher, 92 Jeck Lane, Calderstones, Liverpool L18 JER.

■ 14 year old machine code programmer wants pen pal to exchange tips, hints and useful M/C routines. Tel. (0733) 268801 and ask for Kyle.

■ Is there anybody out there? Hello! I'm a *Dark Star* freak but also interested in writing letters. I am 17 and would like all manner of girls to write. All replies answered. Write to Steve the Hacker, 28 Danescourt Road, West Derby, Liverpool L12 8RB.

■ Male or female pen pal wanted. I am 16 and interested in machine code, basic programming, games, modems, etc. Write to Philip Lavender, 27 Min-Y-Coed, Radyr, Cardiff, South Glamorgan CF4 8AQ, Wales.

## SHEKHANA COMPUTER SERVICES DISCOUNT SPECTRUM SOFTWARE

| *** SPECTRUM ***         |  | RRP   | OUR PRICE | *** SPECTRUM ***               |  | RRP   | OUR PRICE |
|--------------------------|--|-------|-----------|--------------------------------|--|-------|-----------|
| Ghostbusters             |  | 9.95  | 7.50      | Blockbusters                   |  | 7.95  | 7.00      |
| Knights Lore             |  | 9.95  | 7.50      | Eureka                         |  | 14.95 | 12.50     |
| Underworld               |  | 9.95  | 7.50      | American Football              |  | 9.99  | 8.00      |
| Daley Thompson Decathlon |  | 6.90  | 4.99      | Boulder Dash                   |  | 7.95  | 5.95      |
| Matchday                 |  | 7.95  | 6.40      | Bruce Lee                      |  | 7.95  | 6.95      |
| White Lightning          |  | 14.95 | 12.99     | Jewels of Babylon              |  | 6.00  | 4.99      |
| Sherlock Holmes          |  | 14.95 | 12.50     | Alien 8                        |  | 9.99  | 8.00      |
| Doomsday's Revenge       |  | 9.95  | 7.50      | AI Level 9                     |  | 9.95  | 8.25      |
| Everyone A Wally         |  | 9.99  | 7.25      | Fall Guy                       |  | 6.95  | 5.20      |
| Trashman                 |  | 5.95  | 4.45      | Zaxxon                         |  | 7.95  | 6.45      |
| Matchpoint               |  | 7.95  | 5.50      | Atic-Atac                      |  | 5.50  | 3.99      |
| Technic Ted              |  | 5.95  | 4.45      | Moggy                          |  | 5.95  | 4.25      |
| Eddie Kidd Jump          |  | 7.95  | 5.95      | Fighter Pilot                  |  | 7.95  | 6.75      |
| Dark Star                |  | 7.95  | 5.95      | Kong Strikes Back              |  | 6.90  | 5.25      |
| Star Strike              |  | 5.95  | 4.45      | Hobbit                         |  | 14.95 | 12.50     |
| Havoc                    |  | 7.95  | 5.95      | Vahalis                        |  | 14.95 | 11.50     |
| Hunchback II             |  | 6.90  | 5.25      | Chequered Flag                 |  | 6.95  | 5.20      |
| Tir Na Nog               |  | 9.95  | 7.50      | Night Gunner                   |  | 6.95  | 5.50      |
| Aerwolf                  |  | 6.90  | 5.20      | Chinese Juggler                |  | 5.90  | 4.50      |
| Pjamasara                |  | 6.95  | 5.20      | Select!                        |  | 12.49 | 10.50     |
| Blut Max                 |  | 7.95  | 6.50      | Pjamasara                      |  | 6.90  | 5.50      |
| Pete Position            |  | 7.99  | 7.00      | Great Space Race               |  | 14.95 | 9.99      |
| Raid Over Moscow         |  | 7.95  | 6.40      | Alien                          |  | 9.95  | 8.00      |
| World Cup Football       |  | 6.95  | 5.30      | Hampstead                      |  | 9.95  | 7.50      |
| Pitfall II               |  | 7.95  | 6.50      | Night Driver                   |  | 5.95  | 4.25      |
| Valkyrie 17              |  | 9.95  | 7.50      | Backgammon                     |  | 5.95  | 4.50      |
| Gift of the Gods         |  | 9.95  | 7.50      | Avolon                         |  | 7.95  | 6.50      |
| Kung Fu                  |  | 6.95  | 5.50      | Cyclone                        |  | 6.95  | 5.50      |
| Project Future           |  | 6.95  | 5.25      | Bristles                       |  | 7.95  | 6.25      |
| SpideMan                 |  | 9.95  | 7.50      | Space Shuttle                  |  | 7.95  | 7.00      |
| Magic Miner              |  | 5.95  | 4.25      | System 15000                   |  | 6.95  | 6.50      |
| Cyclone                  |  | 5.95  | 4.45      | Testmatch                      |  | 5.95  | 4.50      |
| Beachhead                |  | 7.95  | 6.70      | Flight Simulation              |  | 7.95  | 6.70      |
| Sabre Wolf               |  | 9.99  | 7.50      | Snooker (Visions)              |  | 6.95  | 6.70      |
| Lords of Midnight        |  | 9.95  | 7.50      | Steve Davis Snooker            |  | 7.95  | 6.50      |
| Frank N Stein            |  | 5.95  | 4.45      | Paaman                         |  | 7.99  | 7.00      |
| TLL                      |  | 5.95  | 4.75      | Gilligans Gold                 |  | 5.90  | 4.75      |
| Classic Adventure        |  | 5.95  | 5.50      | Football Manager               |  | 6.95  | 5.50      |
| Monty Mole               |  | 6.95  | 5.50      | Harner Attack                  |  | 5.95  | 4.50      |
| Full Throttle            |  | 5.95  | 5.50      | Air Traffic Control (Mikrogen) |  | 9.95  | 8.25      |
| Twin Kingdom Valley      |  | 7.95  | 6.70      | Jet Set Willy                  |  | 5.95  | 4.45      |
| Scrabble                 |  | 15.95 | 9.99      | Kokotni Witt                   |  | 5.95  | 4.45      |
| Soft Ace                 |  | 4.99  | 4.99      |                                |  |       |           |

Prices include post & packing. Overseas orders please add 50 pence for post. Please made cheques & postal orders payable to: **Shekhana Computer Services, 653 Green Lanes, London N8 0QY** - (Mail Order address only) **Telephone 01-800 3156**. SAE for list. OR

Come and see us personally at - Marbles Shopping Centre, Unit 11, 527-531 Oxford Street, London W1R 1DD (1 min from Marble Arch tube stn). Above discounts applicable only on production of this advert.

# HIRE SPECTRUM SOFTWARE

- \* OVER 500 different titles available for hire including **ARCADE, ADVENTURE, BUSINESS, EDUCATIONAL** etc.
- \* OVER 10,000 tapes in stock. All publisher's originals.
- \* **LOWEST HIRE CHARGES** - hire up to 3 tapes at a time, from only 63p (plus P&P and VAT) for 2 weeks hire.
- \* **FREE printed CATALOGUE**
- \* **FREE** newsletter with hints, tips, reviews, etc.
- \* **TAPES** for sale at **DISCOUNT** prices, (eg **MANIC MINER £2.00**).
- \* **FAST, FAST SERVICE**. All tapes sent by 1st class postage.
- \* **HALF-PRICE OFFER** - LIFE membership **ONLY £3.00** (normally £6.00).
- \* **FREE** first hire tape. (For limited period).
- \* **EUROPEAN MEMBERS WELCOME**. (Payment in Sterling).

Have you ever been disappointed with software you've purchased? Now you can hire it first. If you like it, buy it at £1.00 off our already discounted prices. If you don't, send it back and it will only cost you the hire fee.

**NSL** is the best **SPECTRUM** library, with over 8,000 delighted members, the largest range of tapes and controlled by our computer with 22 mb hard disc. **JOIN TODAY**, or, if you don't believe our claims write or 'phone 01-661 9240 for a catalogue, and check our competitors. We're confident you'll join **NSL**.

## NATIONAL SOFTWARE LIBRARY

42 Harefield Avenue, Cheam, Surrey SM2 7NE.

I enclose £3.00 for **LIFE MEMBERSHIP**. Please rush my membership kit to me. If, within 28 days, I'm not delighted with your service you'll refund my membership fee.

Name \_\_\_\_\_  
Address \_\_\_\_\_



## SPECTRUM BEEP BOOSTER

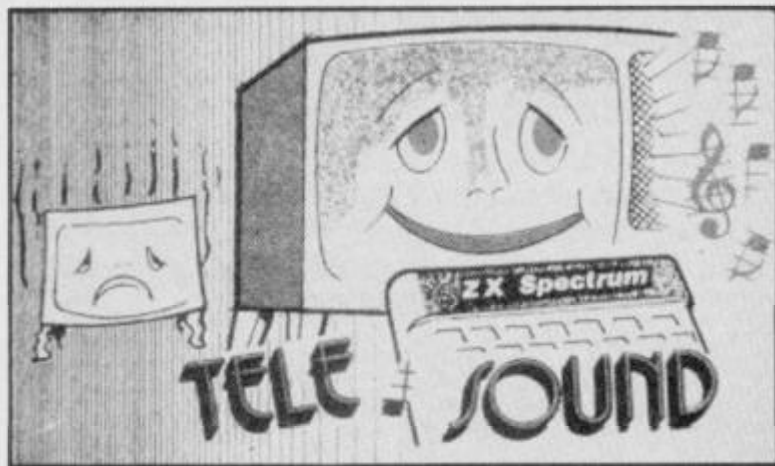

TELESOUND is a tiny electronic circuit which constantly enhances the sound volume and quality of the Spectrum sound output. Adjustable from a whisper to a roar, Telesound provides added realism and excitement for games players and security for programmers. No cutting, no soldering, just connect. TELESOUND also allows you to Load and Save programs without unplugging leads.

TELESOUND gives you real sound for only £9.95 inclusive of post, packing etc. Please state your computer when ordering.

**COMPUSOUND**

DEPT: YS2, 32-33 LANGLEY CLOSE, REDDITCH, WORCESTERSHIRE.  
B98 0ET. TELEPHONE: (0527) 21429 (21439 Answerphone)

DON'T JUST PLAY GAMES!

# EDUCATIONAL SOFTWARE

FOR ANY  
SPECTRUM 16K or 48K

|                  |                          |
|------------------|--------------------------|
| Physics          | O level/CSE Revision Aid |
| Biology          | O Level/CSE Revision Aid |
| Maths            | CSE Revision             |
| Computer Studies | O Level/CSE Revision Aid |
| Science          | Revision 12/14 Years     |
| Maths            | Revision 12/14 Years     |
| Mathematics      | Revision 8/11 Years      |
| Arithmetic       | Revision 7/10 Years      |
| Reasoning        | 11+ Revision             |
| Knowledge        | Quiz 9/99 Years          |

Exceptional value at just £4.95 each post free

**IMMEDIATE DELIVERY BY FIRST CLASS POST**

Cheques/PO to:

Micro-De-Bug Consultancy  
Dept YS, 60 Sir John's Road  
Selly Park, Birmingham, B29 7ER  
Tel: 021 472 7610

DEALER ENQUIRIES WELCOME

# OPPORTUNITY KNOCKS

Once in everybody's lifetime there comes a never-to-be-repeated opportunity. Miss it and it's gone forever. Take it and it could change your life. Big claims, you say but we think they're justified. Can you afford to pass this chance by...

So, you're a brilliant Specky programmer but why haven't you been discovered yet? No-one's beaten a path to your door? Pressed pound notes into your paw? Forced you to drive round in a Ferrari? Well, why not?

What's that? — you've been too busy to write that mega-program that'll take the world by storm. You don't like Ferraris. Excuses, excuses.

## KNOCK, KNOCK

Well, now there can be no more excuses. We're giving you one last chance to make your fame and fortune as a programmer and what a chance it is. Opportunity is knocking — will you close the door on it?

If you've written a program (or you're just looking for a chance like this to sit down and write one) now's the time to go for it. We don't mind if it's an arcade, an adventure, a utility or any other category you care to name. Just so long as it does what it sets out to do. If it's a game we want to have some fun! And a utility's going to have to work hard.

As far as restrictions go, there's really only one more. Your program shouldn't be any longer than 15K. Of course, that means the machine code maniacs will be able to pack more in, but remember we're looking for more than just evidence that you can think in binary. A good program must first of all have a good idea behind it, and that'll come across even if it's written in Basic.

## WHO'S THERE?

Over the next six months we'll be picking out and publishing the best six programs from all of those you send in. And then we're handing them over to your fellow YS readers. We'll be asking them to cast their votes on behalf of the one that they consider to be the overall supreme Spectrum program.

To be voted the best of the best by **Your Spectrum** readers is quite some achievement — we all know how critical you lot can be! And as well as the recognition there'll also be a hefty lump sum waiting to be picked up by each of the six published programmers. But for the top programmer we're offering the chance to have his work marketed by a major software house. More news in the next month as the details are finalised. Watch this space!

So what are you waiting for? If your masterpiece is ready now, don't hang about, send it off to us straight away. If not, you'd better get cracking at the keyboard as we'll be printing the first program in the August issue. A chance like this may never come your way again. Even if you don't make it to the top six, you may still get into print as we'll be letting Gavin take a look at all the programs for Program Power. The address to send your software to is Opportunity Knocks, **Your Spectrum**, 14 Rathbone Place, London W1P 1DE.

Of course, if you still intend to let this opportunity pass you by, you're not going to be left out. It's your votes that'll decide who becomes the **Your Spectrum Supreme Programmer** so be prepared to start typing those programs in. Go for it!



# PROGRAM POWER

Something for everyone in this month's Program Power. Arcade addicts'll go headlong for the Gold Rush and Shooting Gallery, and all you clever clogs'll want to Drop Out and Tascout is one utility that'll have you out for the count! Get those program's powered up.

## DROP OUT

BY B HERIVEL AND M RAPPS

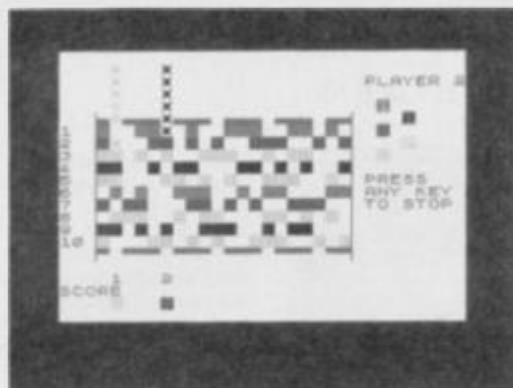

Here's a game that's going to get the old grey matter on the move. Once you've got it sussed though, it'll provide hours of friendly and not so friendly competition.

Here's a clever little program for all you clever Speccy owners out there! The game's designed for 2-5 players and the more of you there are the better the game. The aim is to get six of your counters through the maze-box by moving the sectors of the box to left and right. This clears a path for your counters to drop down. Remember, you're not alone — your opponents will be out to stop you so prepare for some hot competition. All you have to do to destroy one of your opponent's pieces is to land on it. Simple, eh? Just you try it.

Your turn to move a section comes when the computer has rolled five dice. The number of moves you can make to each of the ten sections hangs on the throw of the dice. If you haven't quite followed all that don't worry the instructions are also in the game so you can play and learn at the same time. You're going to need a lot of concentration and some quick thinking to play the game. So, drop in and Drop Out!

```
1 REM B.Herivel & M.Rapps 1984
2 BORDER 6: PAPER 7: INK 0: CLS : PRINT F
LASH 1; AT 5,12; "DROPOUT"; FLASH 0; AT 10,1; "Do
you want instructions? y/n"
3 PAUSE 0: IF INKEY$="y" OR INKEY$="Y" THE
N GO SUB 9600
4 CLS
5 DIM a(10,20): DIM x(5,6,2): DIM b(20): D
IM c(5,6,2): DIM d(5): DIM e(5)
6 DIM q(5): FOR f=1 TO 5: LET q(f)=6: NEXT
f
7 DIM s(5): DIM r(2)
8 INPUT "How many players? (2-5) "; p1: IF
p1<2 OR p1>5 THEN GO TO 18
9 CLS : PRINT FLASH 1; AT 10,10; "PLEASE WA
IT"
10 GO SUB 9000: GO SUB 8000
11 GO SUB 8200
12 FOR t=1 TO p1: PRINT AT 18,t*4;t: NEXT t
13 PRINT AT 2,24; "PLAYER"; AT 19,0; "SCORE"
14 GO SUB 300
```

Lines 5-40 The lines set up the main instructions, call the User Defined Graphics and the screen set-up subroutines. Instructions are also called if required.

```
100 FOR p=1 TO p1
105 PRINT FLASH 1; AT 2,31;p
110 GO SUB 9500
120 FOR d=1 TO 5
130 INPUT "Line "; d; " or "; d+5; "? "; z$:
LET z=CODE z$-48+(9 AND z$="10"): IF z<1 OR z
>10 THEN GO TO 130
135 IF z<>d AND z<>d+5 THEN GO TO 130
138 IF d(d)=0 THEN GO TO 170
140 INPUT "Left or right? l/r "; m$
145 IF m$<>"l" AND m$<>"r" THEN GO TO 140
146 IF m$="r" THEN LET sr=0
147 IF m$="l" THEN LET sr=100
```

```
150 FOR v=1 TO d(d): GO SUB 7000+sr: GO SUB
7500:
160 GO SUB 7600+sr: GO SUB 8200
161 NEXT v
170 NEXT d
180 GO SUB 7200
190 NEXT p
200 GO TO 100
```

Lines 100-200 This is the main playing loop.

```
300 FOR t=1 TO p1: PRINT PAPER e(t): INK 9:
AT 20,t*4;s(t): IF s(t)=6 THEN GO TO 400
310 NEXT t: RETURN
400 PRINT AT 12,25; "PLAYER"; PRINT FLASH 1:
PAPER e(t): INK 9; AT 13,25;t: PRINT AT 14,25
;"WINS!"
405 PRINT AT 2,24; " "
407 FOR f=10 TO 20: BEEP .1,f: NEXT f
410 STOP
```

Lines 300-410 This is the end-of-game routine.

```
7000 FOR y=1 TO 20
7010 LET b(y)=a(z,y-1+(20 AND y=1))
7012 NEXT y
7015 FOR f=1 TO p1: FOR g=1 TO 6: IF c(f,g,1)
=z+5 THEN LET x(f,g,2)=c(f,g,2)+1-(20 AND c(
f,g,2)>21)
7020 NEXT g: NEXT f
7030 RETURN
7100 FOR y=1 TO 20
7110 LET b(y)=a(z,y+1-(20 AND y=20))
7111 NEXT y
7115 FOR f=1 TO p1: FOR g=1 TO 6: IF c(f,g,1)
=z+5 THEN LET x(f,g,2)=c(f,g,2)-1+(20 AND c(
f,g,2)<4)
7120 NEXT g: NEXT f
7130 RETURN
7200 FOR g=6 TO q(p) STEP -1
7210 LET at=ATTR(c(p,g,1)+1,c(p,g,2))
7222 IF at<56 OR at=(56+e(p)) THEN GO TO 724
0
7223 IF c(p,g,1)+1=16 THEN IF SCREEN$(c(p,g
,1)+1,c(p,g,2))<>" " THEN GO TO 7240
7225 IF at>56 AND at<>(56+e(p)) THEN GO SUB
7300
7229 IF c(p,g,1)=99 THEN GO TO 7240
7230 PRINT AT c(p,g,1),c(p,g,2); " ": LET c(p,
g,1)=c(p,g,1)+1: PRINT INK e(p); AT c(p,g,1),
c(p,g,2); "X": IF c(p,g,1)<16 THEN GO TO 7210
7235 PRINT AT c(p,g,1),c(p,g,2); " ": LET s(p)
=s(p)+1: BEEP .2,10: GO SUB 300: LET c(p,g,1)
=99
7240 NEXT g
7245 IF q(p)>1 THEN LET q(p)=q(p)-1
7250 RETURN
7300 FOR h=1 TO p1: FOR j=1 TO 6
7310 IF c(h,j,1)=c(p,g,1)+1 AND c(h,j,2)=c(p,
g,2) THEN LET c(h,j,1)=99: LET s(p)=s(p)+1:
BEEP .2,10: GO SUB 300
7320 NEXT j: NEXT h: RETURN
7500 FOR y=1 TO 20
7510 LET a(z,y)=b(y): NEXT y
7520 FOR f=1 TO p1: FOR g=1 TO 6: IF c(f,g,1)
=z+5 THEN LET c(f,g,2)=x(f,g,2)
7525 NEXT g: NEXT f
7530 RETURN
7600 FOR y=1 TO 20
7610 PRINT PAPER a(z,y); AT z+5,y+2; " "
7620 NEXT y: RETURN
7700 FOR y=20 TO 1 STEP -1
7710 PRINT PAPER a(z,y); AT z+5,y+2; " "
7720 NEXT y: RETURN
```

Lines 7000-7720 This large block of code contains various subroutines to do the complicated maths in the game.

```
8000 FOR x=1 TO 10: FOR y=1 TO 20
8010 PRINT PAPER a(x,y); AT x+5,y+2; " "
```







# SOFT AID

*Feed The World*

## SINCLAIR SPECTRUM

- |                      |                         |
|----------------------|-------------------------|
| SPELLBOUND           | - BEYOND                |
| STARBIKE             | - THE EDGE              |
| KOKOTONI WOLF        | - ELITE                 |
| THE PYRAMID          | - FANTASY               |
| HORACE GOES SKIING   | - MELBOURNE HOUSE/PSION |
| GILLIGANS GOLD       | - OCEAN                 |
| ANT ATTACK           | - QUICKSILVA            |
| 3D TANK DUEL         | - REALTIME              |
| JACK & THE BEANSTALK | - THOR                  |
| SORCERY              | - VIRGIN                |

10 Top titles on one cassette! only

**£4.99**

Features  
the Hit Single  
'Do they know it's  
Christmas?'  
**BAND-AID**

## COMMODORE 64

- |                |               |
|----------------|---------------|
| GUMSHOE        | - A & F       |
| PITFALL        | - ACTIVISION  |
| STARTRADER     | - BUG BYTE    |
| KOKOTONI WOLF  | - ELITE       |
| CHINA MINER    | - INTERCEPTOR |
| GILLIGANS GOLD | - OCEAN       |
| FRED           | - QUICKSILVA  |
| GYROPOD        | - TASKSET     |
| FALCON PATROL  | - VIRGIN      |
| FLAK           | - U.S. GOLD   |

Available from Microdealer UK Ltd.

All proceeds to The Bob Geldof Band-Aid Ethiopian Appeal Fund.

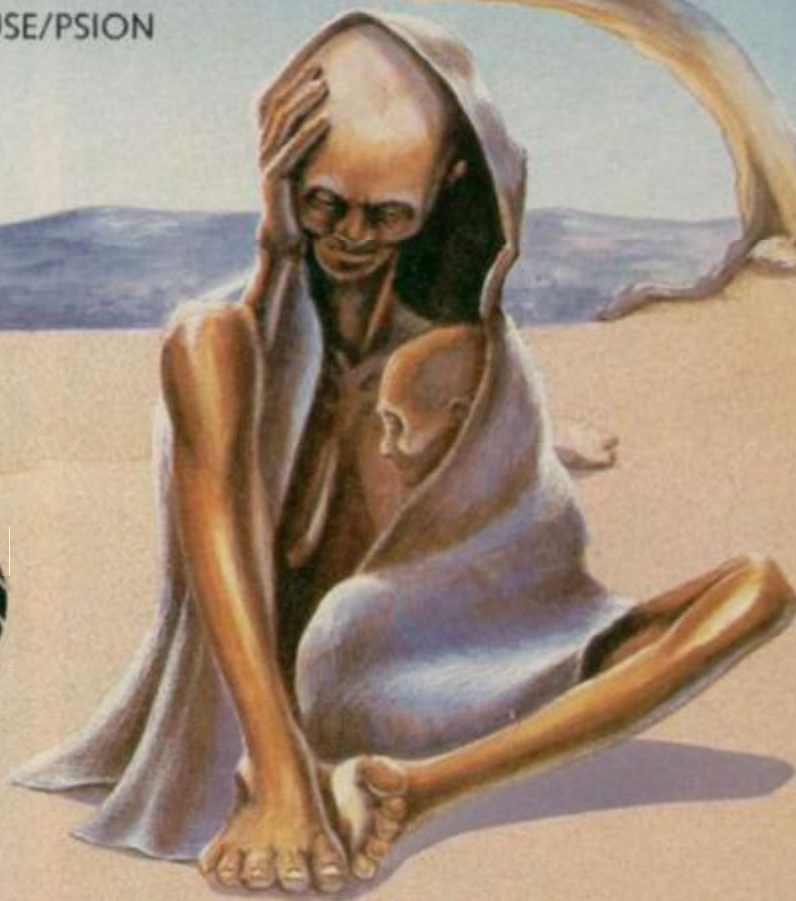

JR



# PROGRAM POWER

```

64 REM ****main loop****
65 PRINT AT x-1,y; INK 7;"Δ";AT x,y; INK 7,
"Λ"
70 GO SUB 500
75 IF SCREEN$(x+1,y)=" " THEN GO SUB 4000
80 IF ATTR(x+1,y)=79 THEN GO SUB 2000
90 IF ATTR(x-2,y)=79 THEN GO SUB 3000
100 IF INKEY$="" THEN GO TO 65
110 BEEP 0.002,20
120 LET pa=pa+1
130 PRINT AT x,y;" ";AT x-1,y;" "
140 LET y=y+(INKEY$="B" AND y<31)-(INKEY$="5
" AND y>0)
150 IF ATTR(x,y)=233 THEN GO SUB 5000
160 IF a<>4 THEN IF ATTR(x,y)=68 THEN GO
SUB 4000
170 IF a=4 THEN IF x=20 AND y=14 OR x=20 AN
D y=16 THEN GO SUB 6000
180 IF pa=130 THEN GO SUB 4000
190 IF ATTR(x,y)=198 THEN GO SUB 7000
200 GO TO 65

```

Lines 64-200 This is the main loop of the program which reads the keyboard and acts upon your keypresses.

```

499 REM moving platforms
500 BEEP .001,20; LET u$=u$(2 TO )+u$(1); LE
T t$=t$(5)+t$( TO 4); PRINT INK 6;AT 11,22;u
$;AT 11,5;u$;AT 16,21;t$;AT 16,6;t$;AT 6,13;t
$
510 PRINT AT 0,0; PAPER 1; INK 7;"SCORE=";sc
;AT 0,13;"LIVES=";l;AT 0,23;"PACES=";pa
530 RETURN

```

Lines 499-530 This routine prints the moving platforms and keeps the score up to date.

```

1099 REM down ladder
2000 IF INKEY$="6" THEN GO TO 2005
2002 RETURN
2005 FOR n=0 TO 4: GO SUB 500; PRINT AT x,y;"
";AT x-1,y;" "; LET x=x+1; BEEP .009,n+2; PR
INT AT x,y;"Λ";AT x-1,y;"Δ"
2010 IF n>1 THEN PRINT AT x-2,y; PAPER 1; IN
K 7;"□"
2015 NEXT n
2020 RETURN

```

Lines 1099-2020 This routine moves Specman down the ladder.

```

2099 REM up ladder
3000 IF INKEY$="7" THEN GO TO 3002
3001 RETURN
3002 FOR n=0 TO 4: GO SUB 500; PRINT AT x,y;"
";AT x-1,y;" "; LET x=x-1; BEEP .009,n+2; PR
INT AT x,y;"Λ";AT x-1,y;"Δ"
3005 IF n>1 THEN PRINT AT x+1,y; INK 7; PAPE
R 1;"□"
3010 NEXT n
3015 RETURN

```

Lines 2099-3015 Similar to the previous routine, this one moves Specman up the ladder.

```

3099 REM fall or die
4000 IF SCREEN$(x+1,y)=" " THEN GO TO 4020
4005 PRINT AT x,y;" ";AT x-1,y;" "; GO SUB 50
0; LET x=x+1; BEEP 0.01,x+5; PRINT AT x,y;"Λ"
;AT x-1,y;"Δ"
4010 GO TO 4000
4020 PRINT AT x,y;"Δ";AT x-1,y;"Δ"; FOR n=0 T
O 20: BEEP 0.01,n+5; NEXT n; LET li=li-1; IF
li=-1 THEN GO SUB 5050
4025 FOR n=0 TO 200: NEXT n; GO TO 6

```

Lines 3099-4025 If you fall down a hole then this routine takes over and prints Specman falling through space. Aaaah!

```

4099 REM touch money
5000 LET b=INT(RND*9)+1; FOR n=0 TO 20: BEEP
0.002,n+3*2; NEXT n; PRINT AT x,y;b; LET sc=
sc+50; LET a=a+1; LET t=t+b; FOR w=0 TO 100:
NEXT w
5010 RETURN

```

Lines 4099-5010 This is the 'touch money' routine which performs all the necessary variable changes when you pick up some money.

```

5049 REM game over
5050 FOR n=30 TO -5 STEP -1: BEEP 0.01,n+9; N
EXT n; PRINT AT 2,20;"GAME OVER";AT 3,20;"P=A
gain";AT 4,20;"S=Stop"
5060 IF INKEY$="p" THEN CLS; GO TO 4
5065 IF INKEY$="a" THEN STOP

```

Lines 5049-5065 This is the end of the game routine.

```

5069 REM got all money, buy gold
5070 GO TO 5060
6000 PRINT AT 19,5;"PRICE="
6010 INPUT a
6020 IF a=t THEN LET a=5; PRINT AT 19,5;"
"; LET sc=sc+100; FOR n=0 TO 10: BEEP .09,
n+10; NEXT n; GO TO 80
6030 IF a<>t THEN GO SUB 4000
6040 RETURN

```

Lines 5069-6040 Once you've collected all the money, this routine allows you to buy the gold.

```

6099 REM complete screen
7000 PRINT AT x,y;" "; FOR y=1 TO 5: FOR x=1
TO 10: BEEP .05,x*2; NEXT x; NEXT y
7005 FOR w=2 TO 300 STEP 2: BEEP .01,w/8; PRI
NT AT 0,6;sc+w; NEXT w
7006 LET sc=sc+w
7010 PRINT AT 3,10; FLASH 1;"WELL DONE"
7020 FOR n=0 TO 400: NEXT n; GO TO 6
7050 RETURN

```

Lines 6099-7050 This routine prints up the message 'well done' when you finish a screen, and then resets the variable ready for the next level.

```

7059 REM instructions
7060 PRINT AT 0,10;" GOLD RUSH";AT 3,0;"7=UP
6=DOWN 5=LEFT 8=RIGHT
"
7070 PRINT ; PRINT ; PRINT "Help Specman coll
ect his"; PRINT ; PRINT "money and buy the GO
LD."
7080 PRINT ; PRINT "He must find out his tota
l "; PRINT ; PRINT "sum and pay his price.";
PRINT ; PRINT "Specman cannot walk too much";
PRINT ; PRINT "130 paces is the max."
7082 PRINT AT 20,5;"PRESS ANY KEY TO PLAY"
7085 IF INKEY$="" THEN GO TO 7085
7090 RETURN

```

Lines 7059-7090 Print the instructions.

```

7999 REM U.D.G's
8000 FOR w=USR "a" TO USR "h"+7: READ x: POKE
w,x; NEXT w
8010 DATA 255,66,36,24,24,36,66,255
8020 DATA 129,255,129,129,129,255,129,129
8030 DATA 24,36,66,66,36,24,255,189,189,60,24
,36,36,66,66,195
8040 DATA 0,127,127,127,0,247,247,247
8050 DATA 24,24,24,24,24,255,255,24,24,24,24,
24,60,126,255,255
8060 DATA 18,149,66,153,60,60,60,24
9000 RETURN

```

Lines 7999-9000 Set up the UDGs.

## TASCOUNT

BY MALCOLM PAKNADEL

Tasword II's a great word processing package but it would be even better with a word count routine. Well, now it's got one — Tascount and it only takes up 60 bytes.

Tascount searches for any character preceded by a space, a graphic character, or a new line and treats this as a new word. It also takes into account right justification and hyphenated words.

To enter the code, first type in the Basic loader program. When RUN, you'll be prompted for a sequence of five numbers followed by a checksum. If your checksum is wrong you'll be given a second chance. The machine code will be saved as a file called "count".



# PROGRAM POWER

Load Tasword as normal and then exit into Basic. Next you've got to edit lines 10 and 25 as directed. Now type 'LOAD "count" CODE', and load up the machine code. Tascount's now incorporated into Tasword and the only difference you'll notice is the word count and text file size in lines and bytes at the foot of the screen. All you've got to do is press 'STOP' to exit from the text file and wait just two seconds. And we got that time on a 19K file — not bad, eh?

Of course, you can always make your own amendments so that Tascount adds just what you want to Tasword. For example, if you're using a shorter text file size, say with TASPRINT, then change the 205 in line 12 of the machine code dump to the highest page boundary that'll completely enclose the text file. So, if the text file ends at address END, change 205 to INT(END/256+1).

You can count on *YS* readers to come up with the best software ideas!

```

10 FOR a=58420 TO 58484 STEP 5
20 LET cs=0
30 PRINT AT 21,0;a;" ";
40 FOR l=1 TO 4
50 INPUT x
60 LET cs=cs+x
70 POKE a+l,x
80 PRINT x;" ";
90 NEXT l
100 INPUT "checksum: ";cs2
110 IF cs2<>cs THEN PRINT AT 21,0; FLASH 1;
"ERROR"; BEEP 1,0; PRINT ;21,0,,; GO TO 20
120 RANDOMIZE USR 3280; RANDOMIZE USR 3280
130 NEXT a
140 SAVE "count"CODE 58420,62
    
```

This is the machine code loader program.

| ADDRESS | DATA                | CHECKSUM |
|---------|---------------------|----------|
| 58420:  | 33,0,125,1,0        | 159      |
| 58425:  | 0,89,125,230,63     | 507      |
| 58430:  | 194,72,228,62,2     | 558      |
| 58435:  | 163,194,72,228,95   | 752      |
| 58440:  | 126,254,33,56,9     | 478      |
| 58445:  | 254,45,40,12,254    | 605      |
| 58450:  | 128,218,98,228,123  | 795      |
| 58455:  | 230,2,95,195,106    | 628      |
| 58460:  | 228,203,35,195,106  | 767      |
| 58465:  | 228,123,30,1,167    | 549      |
| 58470:  | 194,106,228,3,35    | 566      |
| 58475:  | 124,254,205,194,59  | 836      |
| 58480:  | 228,201,201,201,201 | 1032     |

This is the machine code dump. If you don't want to have graphic characters as delimiters, change the 128 in line 7 of the machine code dump to a 255 and add 127 to the checksum value at the end of the line.

```

10 CLS : LET a=USR 64330: LET wc=USR 58420:
GO TO 20
    
```

```

25 PRINT 0;"WORDS=";wc;TAB 11;"LINES=";INT
(a/PEEK 62237+.5);TAB 21;"BYTES=";a: GO SUB
4000: PRINT AT 4,0;"print text file
p"
    
```

These are the alterations you have to make to Tasword so that it can give you the word count option.

## SHOOTING GALLERY

BY ADAM LEONARD

Have a crack at the greatest shooting gallery in the fairground.

If you've never played it before, you're in for a treat. Just shoot the rows of bottles, ducks and cherries with the pellets shown at the bottom of the screen. And make sure you get them all before your time runs out! And watch out for the number '5' flying across the top of the screen amongst the bottles, bag it and you'll have another five pellets to play with. OK, so it's not gonna tax the old grey matter but then we can't all be Einsteins — and it's, oh so, addictive.

Your air rifle's controlled with the following keys; Q to move

right, W to move left and P to fire a pellet. Go on, shoot 'em up!

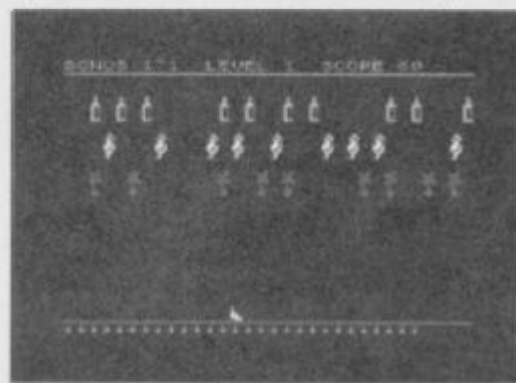

OK, so it's not the most original game in the world. But it's often the straightforward shoot 'em ups that keep you coming back for more! This one will.

```

0>REM Shooting Gallery A
dam Leonard
1 RANDOMIZE : LET hi=0
2 BRIGHT 0: BORDER 1: PAPER 1: INK 6: CLS
: GO SUB 5500
3 LET p=13: LET u=79: RESTORE : GO SUB 100
0
5 LET lev=1: LET s=0: DIM s$(32)
6 BRIGHT 1: BORDER 0: PAPER 0: INK 7: CLS
9 LET b=32: LET fi=0: LET bo=211: LET bo=b
o-lev*10
10 LET a$="  2  2  2  2  2  2  2  2  2  2
"
20 LET b$="  Y  Y  Y  Y  Y  Y  Y  Y  Y  Y
"
30 LET c$="  A  A  A  A  A  A  A  A  A  A
A
"
40 LET d$="  I  E  E  E  E  E  E  E  E  E
E
"
50 LET e$="  X  X  X  X  X  X  X  X  X  X
X
"
60 LET f$="  5  5  5  5  5  5  5  5  5  5
5
"
    
```

Lines 1-60 This part of the program sets up the initial variables.

```

70 PRINT AT 0,0: INK 6;"BONUS";AT 0,11;"LEV
EL";AT 0,20;"SCORE"
75 PRINT AT 21,0: INK 3;"-----"
76 PRINT AT 1,0:"-----"
"
80 PRINT AT 3,0: INK 1; c$;AT 4,0; d$
90 PRINT AT 6,0: INK 2; a$;AT 7,0; b$
100 PRINT AT 9,0: INK 13; e$;AT 10,0; f$
105 LET bo=bo-1: PRINT AT 0,6: INK 3; bo; " ";
AT 0,17; lev; AT 0,26; s: IF b<32 THEN PRINT AT
21,b: INK 3; "-"
106 IF bo=0 THEN GO TO 5000
    
```

Lines 70-100 This bit of code prints up the main parts of the screen display.

```

110 LET a$=a$(2 TO )+a$(1): LET b$=b$(2 TO )
+b$(1): LET c$=c$(32)+c$( TO 31)
120 LET d$=d$(32)+d$( TO 31): LET e$=e$(32)+
e$( TO 31): LET f$=f$(32)+f$( TO 31)
130 LET p=p+(INKEY$="w" AND p<29)-(INKEY$="q
" AND p>0): PRINT AT 20,p;"  " : IF INKEY$="p
" AND b>0 THEN LET b=b-1: GO SUB 150
135 IF RND<.05 AND fi=0 AND b<15 THEN LET c
$(1)=" 5": LET d$(1)="5": LET fi=1
140 GO TO 80
    
```

Lines 110-140 This is the main playing loop.

```

150 BEEP .005,10: BEEP .005,0: FOR f=19 TO 3
STEP -1: PRINT AT f,p+1: INK 5;"  ";AT f+1,p+
1;"  " AND f<19
151 IF SCREEN$(f-1,p+1)="5" THEN LET b=b+5
: PRINT AT 21,b-4: INK 3;"-----": LET fi=0
155 IF SCREEN$(f-1,p+1)<>"  " THEN GO TO 20
0
160 NEXT f
165 PRINT AT 2,p+1;"  ";AT 3,p+1;"  ": BEEP .0
5,-30: PRINT AT 2,p+1;"  "
170 RETURN
200 PRINT AT f,p+1;"  "
205 PRINT AT f-1,p+1;"  ";AT f-2,p+1;"  "
210 IF f=5 THEN LET c$(p+3)=" 5": LET d$(p+3
)=" 5": LET s=s+30
    
```







# PROGRAM POWER

```

5540 PRINT "          DE 25 252525 2525 25 25 25 25
5550 PRINT "          252525 2525 25 252525 2525 25
5560 PRINT "          25 25 25 25 25 25 25 25 25 25 25"
5570 PRINT "          25 25 252525 25 25 2525 252525 252525"
5580 PRINT "          25 25 25 25 25 25 25 25 25 25 25"
5590 PRINT "          252525 25 25 252525 252525 2525 25 25 25"
5600 PRINT AT 14,8; INK 7;"By Adam Leonard"
5605 INK 2; PLOT 64,54; DRAW 118,0; DRAW 0,-1
      : DRAW -118,0
5610 PRINT AT 21,4; INK 7;"Press a key to con
      tinue"
    
```

Lines 5500-5610 This subroutine prints up the title screen at the beginning of each game.

```

6000 DATA 1,10,.3,9,.3,10,.3,13,1.5,18
6010 DATA .3,17,.3,18,.3,20,.3,18
6030 DATA .3,17,.3,18,.3,10,.3,13
6040 DATA 2,17
6050 DATA 1,11,.3,10,.3,11,.3,13,1.5,17
6060 DATA .3,16,.3,17,.3,18,.3,17
6070 DATA .3,16,.3,17,.3,11,.3,17
6090 DATA 2,15
6100 DATA 1,10,.3,9,.3,10,.3,13,1.5,18
6110 DATA .3,17,.3,18,.3,20,.3,18
6120 DATA .3,17,.3,18,.3,10,.3,13
6130 DATA 2,20
6140 DATA 1,20,.3,18,.3,17,.3,15,1.5,13
6150 DATA .3,11,.3,10,.3,8,.3,10,.3,11,.3,13
6160 DATA .3,15,.3,17,.5,18,.1,18,.3,18,.3,18
6170 RESTORE 6000; FOR k=0 TO 12 STEP 3: FOR
      f=1 TO 59
6180 READ dur,note
6190 BEEP dur/2,note+k
6195 IF INKEY$<>" " THEN CLS : INK 7: GO TO 7
    
```

```

000
6200 NEXT f
Lines 6000-6200 This routine is quite clever — its plays the music until you
press a key and stop it.
6210 PAUSE 20; RESTORE 6000; NEXT k; GO TO 61
70
7000 PRINT AT 0,7;"SHOOTING GALLERY"
7010 PRINT AT 0,7; OVER 1;"-----"
8030 PRINT AT 20,0;"Press a key to play"
8040 PAUSE 0; BEEP .1,40
8050 RETURN
    
```

At YS, we try to give you some of the best programs you'll find printed anywhere. But we don't write them — you do.

So, fill in the form below and send it with your red hot program to Gavin Monk, Program Power, *Your Spectrum*, 14 Rathbone Place, London W1P 1DE.

100% PROOF

I realise that Program Power is my passport to fame and fortune. That's why I'm rushing you my 100% machine compatible megaprogram. It's so brilliant, in fact, that all my friends call me Matthew Smith though my real name is . . .

Name .....

Address.....

.....Postcode .....

Telephone number .....

My program's called .....

I also realise that if my game is not completely original or I've blagged it from another mag, YS will ruin my reputation and reduce me to rags.

Signed .....

# Screen Machine.

If you're a 48K Spectrum owner, PAINTPLUS and SCREEN MACHINE can transform your graphics expertise in seconds! Just take a look at some of the things that are possible with a little practice!

YES they were all produced on a ZX Spectrum with no modification and using PAINTPLUS and SCREEN MACHINE. These two packages are incredible . . . PAINTPLUS is a complete upgrade of our previous program Print'n'Plotter Paintbox but with more than 24 new commands and facilities to give you every possible graphic tool.

Some of the new commands are BOX DRAW, ENLARGE TO EDIT, PAPER WASH MODE, UDG GRABBING FROM SCREEN, AUTOMATIC MULTIPLE SCREEN FILES AND UDG BANKS ORGANISER and PAINT ROUTINES IN 5 PATTERNS AVAILABLE IN BOTH NORMAL AND OVER MODE!

SCREEN MACHINE allows you to take the results from PAINTPLUS and manipulate to save memory, recolour, enlarge and reduce, flip and relocate etc.

There's even a complete compiler for text!

Both programs now come with a copy of our 100 page colour book: PRINT'N'PLOTTER PICTURE BOOK and of course a fantastic Demo on side two of the cassette.

Everything is completely Microdrive compatible and easy to transfer to cartridge.

So if you want to produce superb graphics on your 48K Spectrum and you want to do it simply . . . simply send for a copy of PAINTPLUS and SCREEN MACHINE today or ask at your local computer shop.

Now with 100 page Print'n'Plotter Picture Book Full of Hints, Tips, Programs, Instructions and Colour Illustrations!

**Print'n'Plotter Products**



**Send today or ask your local Computer Shop**

Post to: Dept.YS Print'n'Plotter Products Ltd, 19 Borough High Street, London SE1 9SE  
(Credit Card order telephone 01-660 7231 other enquiries 01-403 3622)

Name .....

Address .....

I enclose remittance in full  
Please bill my Access/Visa/Mastercard Number .....

- Please send me the following
- PAINTPLUS at £9.95
  - SCREEN MACHINE at £8.25
  - ADVENTURE PLANNER at £4.50
  - ZX SPECTRUM JOTTER PAD at £9.00
  - ZX PRINTER PAPER 5 ROLLS at £12.00
  - 10 ROLLS at £23.00
- All prices include VAT and carriage for the UK.  
Overseas orders add 20% for additional handling (surface rates).



# CLASSIFIED INFORMATION

CALL DAVID BASKERVILLE FOR RATES AND DETAILS ON ADVERTISING

## SPECTRUM REPAIR SPECIALISTS

48 hour turn round on most machines

£12.50 plus parts and postage

Send your Spectrum together with description of fault to:

**Micro Workshop, Repair Services,**  
273 Moston Lane, Moston, Manchester,  
Lancs M10 9WJ.  
Tel: 061-205 4974

## MAGIC-MESSAGE

Put YOUR name in the HALL OF FAME, be the HERO of the game. Find the hidden list of words in Adventure games. All this is possible with MAGIC MESSAGE which lets you look at and change messages in machine-code games.

Simply load MAGIC MESSAGE, play in main part of game and like Magic messages will appear on your video.

Post £4.95 Free

D/seas, Europe + 50p Others + £1.50  
(Please order as Magic M)

**ZX-GUARANTEED (YS)**  
29 Chadderton Drive, Unsworth,  
Bury, Lancs, BL9 8NL

## SPECIAL AGENT DE-LUXE SPECTRUM COPIER

A multi-purpose yet very easy to use tape copier. Ideal for the experienced or absolute beginner.

### \*\*5 STAR RATINGS\*\*

1. Copies multipart programs all in one Loading.
2. Copies Basic, M/code, Headerless programs upto 51K.
3. Cannot be fooled by weird names which crash other copiers.
4. Can remove Autostart from Basic.
5. YOU can determine Pause between sections.

Once you've experienced this super DE-LUXE silk smooth easy to use Copier, you'll never use any other.

**£5.95**

Overseas: + £1 Europe, + £2 Others

KERR, 1 & 2 The High St,  
King's Lynn, PE20 1BX

## LETTA-HEAD

for the 48k Spectrum

An ENTIRELY ORIGINAL utility program to design and print your own business letterheads, orders, receipts, personal stationery, labels and posters.

- 5 different type faces.
- Proportional spacing.
- Variable character width & height.
- Block scroll, inverse & erase.
- Variable thickness box function.
- Graphics mode for your logo design.
- Special cassette label option.
- Many more features!

Drives Epson type printers (inc. Star, M-T, Shinwa etc.) via most interfaces (IFI, Hilderbay, Kempston, Kempston E, Tasman, Morex, Wafadrive).

Price: £7.50 on cassette, £9.50 on cartridge, or SAE for further details & additional interface compatibility from:

**Bradway Software (YS),**  
33 Conalan Ave., Sheffield,  
S. Yorks., S17 4PG

## SPECTRUM KOPYKAT Version 3

Simply the best. Copying any 16/48K Spectrum program is now as easy as LOADING and SAVEing your own program.

Even unstoppable programs can now be backed up on to a fresh tape.

### NEW FEATURES

- Continuous LOADING - Multipart programs copied in one go \*
- 65400+ byte programs backed up easily \*
- Repeat Copies \*
- plus much, much more. \*

For 16/48K Spectrum only £4.95

## MICRODRIVE KOPYKAT

Transfer your cassette software onto Microdrive simply and easily.

- Automatically relocates machine code programs \*
- Stops and reveals BASIC programs \*

ESSENTIAL UTILITY FOR MICRODRIVE TRANSFER

For 16/48K Spectrum only £4.95

Both programs include FREE Header Reader program.  
Despatched by First Class return of post.

**MEDSOFT**

Dept YS, PO Box 84, Basingstoke, Hampshire, RG25 2LW.

## Epson/Spectrum Printer Format

This is a menu-driven program that will save you scrambling through the manuals every time you set up the printer for something special. On-screen flags show the printer status and in many cases a single key press is all that is needed to switch modes.

A full analysis is provided to enable you to customise the program even if your knowledge of Basic is incomplete.

S.A.E. for details, or £3.00 brings you this handy utility.

## CHEZRON SOFTWARE

605 Loughborough Road, Birstall, Leicester LE4 4NJ

## SPECTRUM RGB OUTPUT

adapt electronic

Impossible? No. Our RGB Output Module is the answer to your prayers.

- True TTL level outputs plus comp syncs.
- Monitor quality pictures - no dot crawl.
- Suits most monitors & monitor/TV's.
- No modifications or internal connections.
- Simply plugs into expansion port.
- No separate power supply required.

Price £34.95 - £1.00 P&P or SAE for details also many ZX & Spectrum addons & parts.

20 STARLING CLOSE, BUCKHURST HILL,  
ESSEX. IG9 5TN. Tel. 01-504-2840

## BANISH LOADING PROBLEMS

AND THE 'WEENY' BEEP ON THE SPECTRUM WITH THE ELIMA TAPELOADER £14.99 OR THE LOUDMOUTH £12.99

Both post free

For details send S.A.E. to:

**Celina Ltd**

Daisy Walk, Sheffield S3 7PY, England Tel: 756728 (801 0742)

# MICROMEND

## COMPUTER REPAIR SERVICE

IF you want a professional repair THEN LET us help you

We don't charge a fixed rate - you only pay the cost of YOUR repair

e.g. FAULT: BLOWN U L A **£22.39**

FAULT: BROKEN KEYBOARD MEMBRANE **£17.65**

ABOVE PRICES INCLUDE P & P:

Maximum charge (excluding abnormal damage) **£30.00**

OUR RATES FOR PRINTERS & ZX 81's, ARE JUST AS FAIR: PLEASE PHONE US FOR QUOTES.

Send your machine with your name, address, tel. no. and fault symptoms, or bring it to

We can supply you with full-size printers and Tasman Software products Please write for details

**Micromend**  
8 Manor Drive  
Leeds LS6 1DE  
TEL. (0532) 742858

YOUR SPECTRUM DOES NOT CONDONE SOFTWARE PIRACY



# CLASSIFIED INFORMATION

CALL DAVID BASKERVILLE FOR RATES AND DETAILS ON ADVERTISING

**Fast  
Spectrum  
Repairs**  
Average  
Repairs  
£15



**MANCOMP  
LTD.**

**FIRST CO. IN ALL  
U.K. TO INTRODUCE  
WHILE-U-WAIT  
SERVICE. NOW FIRST  
TO OFFER AN INTER-  
NATIONAL REPAIR  
SERVICE.**

- MOST SPECTRUMS REPAIRS IN 45 MINS.
- PLEASE PHONE FOR APPOINTMENT FIRST.
- OR PHONE/SEND SEPCTRUM FOR FREE ESTIMATES. ENC £1.80 (U.K., I.O.M., EIRE, C.I.) £6.50 (EUROPE/ SCANDANAVIA).
- NO HIDDEN HANDLING CHARGES.
- 24 HR TURNAROUND.
- EVERY MICRO INSURED FOR RETURN JOURNEY.
- OPEN TILL 7 P.M. MON-SAT.

"I have come across a firm that will be more than willing to advise you as to how to remedy your problem. They are called MANCOMP, and as well as repairing faulty Spectrums, are also quite willing to discuss your problems with you, and offer reasonably cheap, and (more importantly) correct cures"

PHIL ROGERS 'PEEK & POKE'  
"POPULAR COMPUTING  
WEEKLY" JAN 1985. (VOL IV  
NO 1)

**MANCOMP LTD.  
(DEPT YS)  
PRINTWORKS LANE  
MANCHESTER  
M19 3JP  
061-224 1888**

*Engineers urgently required*

## MICRODRIVE-WAFADRIVE TRANSFER TAPES

Transfer majority of your games to WAFADRIVE or MICRODRIVE using the 007WD or 007MD tapes. These use the Semi-Automatic method proved to be the MOST successful available. Includes transferring of Headerless programs & programs in map area.

The Wafadrive 007WD includes system to greatly reduce Loading time for multipart programs.

Longer programs/Hyper Loads can be transferred to WAFADRIVE using techniques printed in Newsletter of MICRODRIVE & WAFADRIVE EXCHANGE. Scrabble, Knightlore, etc, etc.

007WD or 007MD on cassette.....£5.95  
007WD on WAFADRIVE.....£8.95  
007MD on CARTRIDGE.....£7.95  
O/seas, Europe + 55p. Others + £1.55

MICRODRIVE/WAFADRIVE  
EXCHANGE CLUB.

Membership is just £6 for 12 issues  
(£9, Europe, £12 elsewhere).

### ZX-GUARANTEED (SPU)

29 Chadderton Drive, Unsworth,  
Bury, Lancs, BL9 8NL  
Tel: 061-766 5712



## CABINETS

A range of Cabinets especially designed for your home computer system. Keep it dust free, tidy and secure.

Send S.A.E.  
for Colour LEAFLET

**MARCOL CABINETS** Solent Business Centre,  
Millbrook Rd West, Southampton SO10HW  
Tel: (0703) 774832 (24 hr. answering service)

## SINCLAIR SERVICE CENTRE

We have the spares for all repairs to:  
Spectrum, ZX81, Interface I,  
Microdrive and Ram Pack.

Spectrum.....£10.00 + Parts  
ZX81.....£7.50 + Parts  
Interface I.....£7.50 + Parts  
Microdrive.....£7.50 + Parts  
Rampack.....£7.50 + Parts  
All units repaired to original standard.

Using genuine Sinclair spares, by our HNC qualified staff.

Also available: Spectrum Memory update 16-48k fitted by us .....£28.50.  
From

### QUANTUM

33 City Arcade, Coventry  
West Midlands, CV 3HX  
or phone: Coventry (0203) 24632

## STOP-REVEAL

Genuinely let you:

1. **STOP** virtually all programs, Basic, M/code & Headerless even if protected.

2. **REVEALS** hidden Basic in M/code programs. (Could be clues in an Adventure game).

3. **LISTS** actual M/code on screen. Now you can STOP, LIST, MODIFY, STUDY most Spectrum programs at leisure. Includes a DISASSEMBLER so could even study Sinclair ROM, etc. Plus the most Advanced HEADER-READER ever written, plus pages of super SECRETS OF THE TRADE explaining professional methods used to hide lines/programs, etc.

**EVEN STOPS/REVEALS PROGRAMS WHICH ARE A GENUINE 48K LONG.**

**£5.95**

Overseas: + £1 Europe,  
+ £2 Others.

**KERR, 1 & 2 The High St.  
King's Lynn, PE20 1BX**

## SPECTRUM UTILITIES

for 48k Spectrum/Spectrum +

Supersort.....£4.00  
Fast Machine Code Sort called from BASIC. Easy to use. Sorts 100 records. 100 bytes long in average 6 seconds.

Basic Toolkit.....£6.95  
Renummer, delete block of lines, remove REM's, trace, facility to vary program run speed with trace operational for debugging. Display of memory used, no of lines of BASIC.

Clock.....£4.00  
Real time clock displayed on screen. Continuously updated. Leave running whilst playing your favourite game. Will not affect speed of Spectrum.

Catalogue.....£4.00  
A true Microdrive Cat. Filename, no of sectors, filetype, BASIC autostart line, CODE load address, option to print to ZX printer.

For fast despatch send cheque/PO to:

### KM SYSTEMS

18 Comfrey Court, Grays, Essex

All above programs written in Z80 machine code

## SPECTRUM REPAIRS

We expertly repair Spectrums for £17 inclusive of parts and labour and return postage.

Spectrums upgraded 48K for £34. Keyboard faults only £12.

**R.A. ELECTRONICS**  
133 London Road, South  
Lowestoft, Suffolk  
Tel: (0502) 66289

## SPECTRUM REPAIRS A Better Deal from Micro-World

|                                                                                     |        |
|-------------------------------------------------------------------------------------|--------|
| REPLACEMENT OF MIC, EAR & POWER SOCKET                                              | £8.95  |
| KEYBOARD FAULTS: Replacement of Membrane, Mat & Plate (Note all three are replaced) | £13.95 |
| NEW CASE UPPER & LOWER Inc new keyboard as above                                    | £17.95 |
| ALL OTHER FAULTS 16K Spectrum                                                       | £17.95 |
| 48K Spectrum                                                                        | £22.95 |
| POWER SUPPLIES (Spectrum - ZX81)                                                    | £9.95  |
| 16-48K UPGRADES (12 months warranty)                                                | £27.95 |

- Prices fully inclusive of VAT & Return P&P
- 48hr turn round on most machines
- 3 months warranty on repairs
- Send SPECTRUM ONLY suitably packed clearly stating fault, your name & address, cheque or postal order to:

### Micro-World Computers (YS)

1006/1010 Manchester Rd, Linthwaite, Huddersfield HD7 5QQ  
TEL 0484-846117 Showroom open 9-5.30, 6 days

YOUR SPECTRUM DOES NOT CONDONE SOFTWARE PIRACY



# BACK ISSUES

You can now obtain any of these back issues of *Your Spectrum* by filling in the coupon below and enclosing £1.10 for each issue. Also, our shop is open Monday to Friday, 9.30am to 5.30pm. The address is 14 Rathbone Place, London W1P 1DE.

# BLITZ



**ISSUE 1 (DEC/JAN 1984)**  
**REVIEWS**  
 Currah's MicroSpeech, general computing books, joysticks.  
**FEATURES**  
 Speech synthesis, Toni Baker's machine code break-out, Spectrum communications, DIY keyboard buffer, machine code scrolling.  
**GAMES**  
 Chess packages.



**ISSUE 5 (JULY 1984)**  
**REVIEWS**  
 British Micro's Grafpad, DIY computing books.  
**FEATURES**  
 Computerised bulletin boards and modems, software for printer interfaces, ZIP compiler [Pt. 3], DIY joystick interface.  
**GAMES**  
 Gilsoft's *The Quill*.



**ISSUE 7 (SEPTEMBER 1984)**  
**REVIEWS**  
 Add-on keyboards.  
**FEATURES**  
 Spectrum sprites, The 64K Speccy? DIY Centronics interface [pt. 2], stretching Basic's command set.  
**GAMES**  
 Bug-Byte's *Rapcallion*.



**ISSUE 8 (OCTOBER 1984)**  
**REVIEWS**  
 Graphics toolkits, programming languages books.  
**FEATURES**  
 Microdrive recovery, Project 3 revisited, multi-tasking your Spectrum, YS MegaBasic [Pt. 1].  
**GAMES**  
 Vortex's T.L.L.



**ISSUE 9 (NOVEMBER 1984)**  
**REVIEWS**  
 The Spectrum+ preview, Spectrum speech synthesisers.  
**FEATURES**  
 Spectrum and QL link, YS MegaBasic [Pt. 2].  
**GAMES**  
 Frank N. Stein, Astronaut, Mummy Mole, Lords of Midnight, Sherlock, The Hobbit.



**ISSUE 10 (DEC/JAN 1985)**  
**REVIEWS**  
 ZX Spectrum+ review.  
**FEATURES**  
 Codebusters [Pt. 1], Interface ROMs, YS MegaBasic [Pt. 3], M/C Sprite Designer.  
**GAMES**  
 Dent Ex Machina, Hampstead, Peter Pan, Eureka.



**ISSUE 11 (FEBRUARY 1985)**  
**REVIEWS**  
 The Touchmaster.  
**FEATURES**  
 Machine code commands, Spectrum pantograph, Codebusters [Pt. 2].  
**GAMES**  
 Ultimate's *Underworld*, Valkyrie 17, *Tu Na Nog*.



**ISSUE 12 (MARCH 1985)**  
**REVIEWS**  
 Music packages.  
**FEATURES**  
 Multisearch, Mac Man, Harry Hacker, Tuning UP.  
**GAMES**  
 Ghostbusters, Ghoulies, Doomdark's Revenge.



**ISSUE 13 (APRIL 1985)**  
**REVIEWS**  
 Microdrives, Megademo.  
**FEATURES**  
 Program Power, Screen scroller, Big Deal.  
**GAMES**  
 Kong Strikes Back, Hunchback II, JSW.



**ISSUE 14 (MAY 1985)**  
**REVIEWS**  
 Speed Trials.  
**FEATURES**  
 It's A Cracker, Patching Up The Drives.  
**GAMES**  
 Alien 8, Emerald Isle, The Illustrator.

## ORDER YOUR BACK ISSUES NOW!

Please send me the following back issues of *Your Spectrum* (£1-10 each including postage and packing).

- |                                  |                                   |                                   |                                   |
|----------------------------------|-----------------------------------|-----------------------------------|-----------------------------------|
| <input type="checkbox"/> Issue 1 | <input type="checkbox"/> Issue 8  | <input type="checkbox"/> Issue 11 | <input type="checkbox"/> Issue 14 |
| <input type="checkbox"/> Issue 5 | <input type="checkbox"/> Issue 9  | <input type="checkbox"/> Issue 12 |                                   |
| <input type="checkbox"/> Issue 7 | <input type="checkbox"/> Issue 10 | <input type="checkbox"/> Issue 13 |                                   |

Issues 2, 3, 4 and 6 are now sold out, so don't waste your time ordering them!

I enclose a cheque/Postal Order for £.....made payable to SportsScene Specialist Press Ltd.

Name .....

Address .....

..... Postcode .....

Date .....

Please fill in this form and mail it immediately to:  
**Your Spectrum, Back Issues, PO Box 320, London N21 2NB.**

You can use a photocopy of this form if you don't want to deface your issue.



# FAST REPAIRS

First company in all UK, to introduce while-u-wait service. Now first to offer an international repair service.

I have come across a firm that will be more than willing to advise you as to how to remedy your problem. They are called MANCOMP, and as well as repairing faulty Spectrums, are also quite willing to discuss your problems with you, and offer reasonably cheap, and (more importantly) correct cures.

**PHIL ROGERS 'Peek & Poke'**  
"POPULAR COMPUTING WEEKLY"  
January 1985 (Vol IV No 1).

"Prompt... reasonably priced... delighted"  
**C. TOWNEND**  
(SHEFFIELD)

"Thanks for your speedy service"  
**L. J. TONKS**  
(PRESTON)

"Your service still remains first class"  
**J. BOURNE**  
(BEXHILL ON SEA)

"I only posted it on Tuesday and received it back on Thursday... two days later! I've never had such service"  
**K. I. CAIRNS**  
(LEEDS)

"Thank you for your excellent service"  
**A. WALLACE**  
(BEDDINGTON)

"Excellent and quick"  
**B. P. ANDERTON**  
(MAIDSTONE)

"Fast service... not too pricey!"  
**J. TANT**  
(WOLINGHAM)

**AVERAGE £15**

● PHONE/SEND SPECTRUM

FOR FREE ESTIMATES, ENC £1.80 (U.K. I.O.M. EIRE, C.I.) £6.50

(EUROPEAN/SCANDINAVIA) ● NO HIDDEN HANDLING CHARGES

● 24 HOUR TURNAROUND ● OPEN TILL 7PM MON - SAT

● KEYBOARD FAULTS £9

280 - £1.95\* (p&p 20p)  
4116 - £1.10\* (p&p 20p)  
4532 - £3.00\* (p&p 20p)  
Upgrade Kit - £27.00 (p&p £1)  
Upgrade Fitted - £34.00

**MANCOMP LTD.**  
(Dept PCW), Printworks Lane,  
Manchester M19 3JP.  
**Tel: 061-224 1888**

# MANCOMP LTD.

## GARDENERS

\*\*\*\*\*

### CHOOSE THE FLOWERS YOU WANT

### NOT JUST THE ONES YOU KNOW!

#### with the Garden Plant Directory

- ★ Find your ideal plant (on up to 5 requirements out of 17... height, sun, water and soil needs, month of flowering, colour, etc.) from 350 flowers, shrubs and garden trees - within seconds.
- ★ Look up plants you know by Latin names, common names or parts of names (e.g. 'lily' displays nine different lilies, for which you can get full details within 60 seconds).

To order cassettes for the 48k SINCLAIR SPECTRUM, send cheque/PO. for £8.95 to

**PRACTICAL SOFTWARE, DEPT. YS, 40 WORPLE ROAD, LONDON, SW19.**

# THOUGHTS & CROSSES

37 MARKET STREET, HECKMONDWIKE, WEST YORKS.

GENERAL ENQUIRIES TELEPHONE 0924 402337

CREDIT CARD ORDERS TELEPHONE (0924) 409753

| Title      | Company | R.P.P. | Price | Title      | Company | R.P.P. | Price | Title      | Company | R.P.P. | Price | Title      | Company | R.P.P. | Price |
|------------|---------|--------|-------|------------|---------|--------|-------|------------|---------|--------|-------|------------|---------|--------|-------|
| Adventures | Adrian  | 5.95   | 5.95  | Adventures | Adrian  | 5.95   | 5.95  | Adventures | Adrian  | 5.95   | 5.95  | Adventures | Adrian  | 5.95   | 5.95  |
| Adventures | Adrian  | 5.95   | 5.95  | Adventures | Adrian  | 5.95   | 5.95  | Adventures | Adrian  | 5.95   | 5.95  | Adventures | Adrian  | 5.95   | 5.95  |
| Adventures | Adrian  | 5.95   | 5.95  | Adventures | Adrian  | 5.95   | 5.95  | Adventures | Adrian  | 5.95   | 5.95  | Adventures | Adrian  | 5.95   | 5.95  |
| Adventures | Adrian  | 5.95   | 5.95  | Adventures | Adrian  | 5.95   | 5.95  | Adventures | Adrian  | 5.95   | 5.95  | Adventures | Adrian  | 5.95   | 5.95  |
| Adventures | Adrian  | 5.95   | 5.95  | Adventures | Adrian  | 5.95   | 5.95  | Adventures | Adrian  | 5.95   | 5.95  | Adventures | Adrian  | 5.95   | 5.95  |
| Adventures | Adrian  | 5.95   | 5.95  | Adventures | Adrian  | 5.95   | 5.95  | Adventures | Adrian  | 5.95   | 5.95  | Adventures | Adrian  | 5.95   | 5.95  |
| Adventures | Adrian  | 5.95   | 5.95  | Adventures | Adrian  | 5.95   | 5.95  | Adventures | Adrian  | 5.95   | 5.95  | Adventures | Adrian  | 5.95   | 5.95  |
| Adventures | Adrian  | 5.95   | 5.95  | Adventures | Adrian  | 5.95   | 5.95  | Adventures | Adrian  | 5.95   | 5.95  | Adventures | Adrian  | 5.95   | 5.95  |
| Adventures | Adrian  | 5.95   | 5.95  | Adventures | Adrian  | 5.95   | 5.95  | Adventures | Adrian  | 5.95   | 5.95  | Adventures | Adrian  | 5.95   | 5.95  |
| Adventures | Adrian  | 5.95   | 5.95  | Adventures | Adrian  | 5.95   | 5.95  | Adventures | Adrian  | 5.95   | 5.95  | Adventures | Adrian  | 5.95   | 5.95  |
| Adventures | Adrian  | 5.95   | 5.95  | Adventures | Adrian  | 5.95   | 5.95  | Adventures | Adrian  | 5.95   | 5.95  | Adventures | Adrian  | 5.95   | 5.95  |
| Adventures | Adrian  | 5.95   | 5.95  | Adventures | Adrian  | 5.95   | 5.95  | Adventures | Adrian  | 5.95   | 5.95  | Adventures | Adrian  | 5.95   | 5.95  |
| Adventures | Adrian  | 5.95   | 5.95  | Adventures | Adrian  | 5.95   | 5.95  | Adventures | Adrian  | 5.95   | 5.95  | Adventures | Adrian  | 5.95   | 5.95  |
| Adventures | Adrian  | 5.95   | 5.95  | Adventures | Adrian  | 5.95   | 5.95  | Adventures | Adrian  | 5.95   | 5.95  | Adventures | Adrian  | 5.95   | 5.95  |
| Adventures | Adrian  | 5.95   | 5.95  | Adventures | Adrian  | 5.95   | 5.95  | Adventures | Adrian  | 5.95   | 5.95  | Adventures | Adrian  | 5.95   | 5.95  |
| Adventures | Adrian  | 5.95   | 5.95  | Adventures | Adrian  | 5.95   | 5.95  | Adventures | Adrian  | 5.95   | 5.95  | Adventures | Adrian  | 5.95   | 5.95  |
| Adventures | Adrian  | 5.95   | 5.95  | Adventures | Adrian  | 5.95   | 5.95  | Adventures | Adrian  | 5.95   | 5.95  | Adventures | Adrian  | 5.95   | 5.95  |
| Adventures | Adrian  | 5.95   | 5.95  | Adventures | Adrian  | 5.95   | 5.95  | Adventures | Adrian  | 5.95   | 5.95  | Adventures | Adrian  | 5.95   | 5.95  |
| Adventures | Adrian  | 5.95   | 5.95  | Adventures | Adrian  | 5.95   | 5.95  | Adventures | Adrian  | 5.95   | 5.95  | Adventures | Adrian  | 5.95   | 5.95  |
| Adventures | Adrian  | 5.95   | 5.95  | Adventures | Adrian  | 5.95   | 5.95  | Adventures | Adrian  | 5.95   | 5.95  | Adventures | Adrian  | 5.95   | 5.95  |
| Adventures | Adrian  | 5.95   | 5.95  | Adventures | Adrian  | 5.95   | 5.95  | Adventures | Adrian  | 5.95   | 5.95  | Adventures | Adrian  | 5.95   | 5.95  |
| Adventures | Adrian  | 5.95   | 5.95  | Adventures | Adrian  | 5.95   | 5.95  | Adventures | Adrian  | 5.95   | 5.95  | Adventures | Adrian  | 5.95   | 5.95  |
| Adventures | Adrian  | 5.95   | 5.95  | Adventures | Adrian  | 5.95   | 5.95  | Adventures | Adrian  | 5.95   | 5.95  | Adventures | Adrian  | 5.95   | 5.95  |
| Adventures | Adrian  | 5.95   | 5.95  | Adventures | Adrian  | 5.95   | 5.95  | Adventures | Adrian  | 5.95   | 5.95  | Adventures | Adrian  | 5.95   | 5.95  |
| Adventures | Adrian  | 5.95   | 5.95  | Adventures | Adrian  | 5.95   | 5.95  | Adventures | Adrian  | 5.95   | 5.95  | Adventures | Adrian  | 5.95   | 5.95  |
| Adventures | Adrian  | 5.95   | 5.95  | Adventures | Adrian  | 5.95   | 5.95  | Adventures | Adrian  | 5.95   | 5.95  | Adventures | Adrian  | 5.95   | 5.95  |
| Adventures | Adrian  | 5.95   | 5.95  | Adventures | Adrian  | 5.95   | 5.95  | Adventures | Adrian  | 5.95   | 5.95  | Adventures | Adrian  | 5.95   | 5.95  |
| Adventures | Adrian  | 5.95   | 5.95  | Adventures | Adrian  | 5.95   | 5.95  | Adventures | Adrian  | 5.95   | 5.95  | Adventures | Adrian  | 5.95   | 5.95  |
| Adventures | Adrian  | 5.95   | 5.95  | Adventures | Adrian  | 5.95   | 5.95  | Adventures | Adrian  | 5.95   | 5.95  | Adventures | Adrian  | 5.95   | 5.95  |
| Adventures | Adrian  | 5.95   | 5.95  | Adventures | Adrian  | 5.95   | 5.95  | Adventures | Adrian  | 5.95   | 5.95  | Adventures | Adrian  | 5.95   | 5.95  |
| Adventures | Adrian  | 5.95   | 5.95  | Adventures | Adrian  | 5.95   | 5.95  | Adventures | Adrian  | 5.95   | 5.95  | Adventures | Adrian  | 5.95   | 5.95  |
| Adventures | Adrian  | 5.95   | 5.95  | Adventures | Adrian  | 5.95   | 5.95  | Adventures | Adrian  | 5.95   | 5.95  | Adventures | Adrian  | 5.95   | 5.95  |
| Adventures | Adrian  | 5.95   | 5.95  | Adventures | Adrian  | 5.95   | 5.95  | Adventures | Adrian  | 5.95   | 5.95  | Adventures | Adrian  | 5.95   | 5.95  |
| Adventures | Adrian  | 5.95   | 5.95  | Adventures | Adrian  | 5.95   | 5.95  | Adventures | Adrian  | 5.95   | 5.95  | Adventures | Adrian  | 5.95   | 5.95  |
| Adventures | Adrian  | 5.95   | 5.95  | Adventures | Adrian  | 5.95   | 5.95  | Adventures | Adrian  | 5.95   | 5.95  | Adventures | Adrian  | 5.95   | 5.95  |
| Adventures | Adrian  | 5.95   | 5.95  | Adventures | Adrian  | 5.95   | 5.95  | Adventures | Adrian  | 5.95   | 5.95  | Adventures | Adrian  | 5.95   | 5.95  |
| Adventures | Adrian  | 5.95   | 5.95  | Adventures | Adrian  | 5.95   | 5.95  | Adventures | Adrian  | 5.95   | 5.95  | Adventures | Adrian  | 5.95   | 5.95  |
| Adventures | Adrian  | 5.95   | 5.95  | Adventures | Adrian  | 5.95   | 5.95  | Adventures | Adrian  | 5.95   | 5.95  | Adventures | Adrian  | 5.95   | 5.95  |
| Adventures | Adrian  | 5.95   | 5.95  | Adventures | Adrian  | 5.95   | 5.95  | Adventures | Adrian  | 5.95   | 5.95  | Adventures | Adrian  | 5.95   | 5.95  |
| Adventures | Adrian  | 5.95   | 5.95  | Adventures | Adrian  | 5.95   | 5.95  | Adventures | Adrian  | 5.95   | 5.95  | Adventures | Adrian  | 5.95   | 5.95  |
| Adventures | Adrian  | 5.95   | 5.95  | Adventures | Adrian  | 5.95   | 5.95  | Adventures | Adrian  | 5.95   | 5.95  | Adventures | Adrian  | 5.95   | 5.95  |
| Adventures | Adrian  | 5.95   | 5.95  | Adventures | Adrian  | 5.95   | 5.95  | Adventures | Adrian  | 5.95   | 5.95  | Adventures | Adrian  | 5.95   | 5.95  |
| Adventures | Adrian  | 5.95   | 5.95  | Adventures | Adrian  | 5.95   | 5.95  | Adventures | Adrian  | 5.95   | 5.95  | Adventures | Adrian  | 5.95   | 5.95  |
| Adventures | Adrian  | 5.95   | 5.95  | Adventures | Adrian  | 5.95   | 5.95  | Adventures | Adrian  | 5.95   | 5.95  | Adventures | Adrian  | 5.95   | 5.95  |
| Adventures | Adrian  | 5.95   | 5.95  | Adventures | Adrian  | 5.95   | 5.95  | Adventures | Adrian  | 5.95   | 5.95  | Adventures | Adrian  | 5.95   | 5.95  |
| Adventures | Adrian  | 5.95   | 5.95  | Adventures | Adrian  | 5.95   | 5.95  | Adventures | Adrian  | 5.95   | 5.95  | Adventures | Adrian  | 5.95   | 5.95  |
| Adventures | Adrian  | 5.95   | 5.95  | Adventures | Adrian  | 5.95   | 5.95  | Adventures | Adrian  | 5.95   | 5.95  | Adventures | Adrian  | 5.95   | 5.95  |
| Adventures | Adrian  | 5.95   | 5.95  | Adventures | Adrian  | 5.95   | 5.95  | Adventures | Adrian  | 5.95   | 5.95  | Adventures | Adrian  | 5.95   | 5.95  |
| Adventures | Adrian  | 5.95   | 5.95  | Adventures | Adrian  | 5.95   | 5.95  | Adventures | Adrian  | 5.95   | 5.95  | Adventures | Adrian  | 5.95   | 5.95  |
| Adventures | Adrian  | 5.95   | 5.95  | Adventures | Adrian  | 5.95   | 5.95  | Adventures | Adrian  | 5.95   | 5.95  | Adventures | Adrian  | 5.95   | 5.95  |
| Adventures | Adrian  | 5.95   | 5.95  | Adventures | Adrian  | 5.95   | 5.95  | Adventures | Adrian  | 5.95   | 5.95  | Adventures | Adrian  | 5.95   | 5.95  |
| Adventures | Adrian  | 5.95   | 5.95  | Adventures | Adrian  | 5.95   | 5.95  | Adventures | Adrian  | 5.95   | 5.95  | Adventures | Adrian  | 5.95   | 5.95  |
| Adventures | Adrian  | 5.95   | 5.95  | Adventures | Adrian  | 5.95   | 5.95  | Adventures | Adrian  | 5.95   | 5.95  | Adventures | Adrian  | 5.95   | 5.95  |
| Adventures | Adrian  | 5.95   | 5.95  | Adventures | Adrian  | 5.95   | 5.95  | Adventures | Adrian  | 5.95   | 5.95  | Adventures | Adrian  | 5.95   | 5.95  |
| Adventures | Adrian  | 5.95   | 5.95  | Adventures | Adrian  | 5.95   | 5.95  | Adventures | Adrian  | 5.95   | 5.95  | Adventures | Adrian  | 5.95   | 5.95  |
| Adventures | Adrian  | 5.95   | 5.95  | Adventures | Adrian  | 5.95   | 5.95  | Adventures | Adrian  | 5.95   | 5.95  | Adventures | Adrian  | 5.95   | 5.95  |
| Adventures | Adrian  | 5.95   | 5.95  | Adventures | Adrian  | 5.95   | 5.95  | Adventures | Adrian  | 5.95   | 5.95  | Adventures | Adrian  | 5.95   | 5.95  |
| Adventures | Adrian  | 5.95   | 5.95  | Adventures | Adrian  | 5.95   | 5.95  | Adventures | Adrian  | 5.95   | 5.95  | Adventures | Adrian  | 5.95   | 5.95  |
| Adventures | Adrian  | 5.95   | 5.95  | Adventures | Adrian  | 5.95   | 5.95  | Adventures | Adrian  | 5.95   | 5.95  | Adventures | Adrian  | 5.95   | 5.95  |
| Adventures | Adrian  | 5.95   | 5.95  | Adventures | Adrian  | 5.95   | 5.95  | Adventures | Adrian  | 5.95   | 5.95  | Adventures | Adrian  | 5.95   | 5.95  |
| Adventures | Adrian  | 5.95   | 5.95  | Adventures | Adrian  | 5.95   | 5.95  | Adventures | Adrian  | 5.95   | 5.95  | Adventures | Adrian  | 5.95   | 5.95  |
| Adventures | Adrian  | 5.95   | 5.95  | Adventures | Adrian  | 5.95   | 5.95  | Adventures | Adrian  | 5.95   | 5.95  | Adventures | Adrian  | 5.95   | 5.95  |
| Adventures | Adrian  | 5.95   | 5.95  | Adventures | Adrian  | 5.95   | 5.95  | Adventures | Adrian  | 5.95   | 5.95  | Adventures | Adrian  | 5.95   | 5.95  |
| Adventures | Adrian  | 5.95   | 5.95  | Adventures | Adrian  | 5.95   | 5.95  | Adventures | Adrian  | 5.95   | 5.95  | Adventures | Adrian  | 5.95   | 5.95  |
| Adventures | Adrian  | 5.95   | 5.95  | Adventures | Adrian  | 5.95   | 5.95  | Adventures | Adrian  | 5.95   | 5.95  | Adventures | Adrian  | 5.95   | 5.95  |
| Adventures | Adrian  | 5.95   | 5.95  | Adventures | Adrian  | 5.95   | 5.95  | Adventures | Adrian  | 5.95   | 5.95  | Adventures | Adrian  | 5.95   | 5.95  |
| Adventures | Adrian  | 5.95   | 5.95  | Adventures | Adrian  | 5.95   | 5.95  | Adventures | Adrian  | 5.95   | 5.95  | Adventures | Adrian  | 5.95   | 5.95  |
| Adventures | Adrian  | 5.95   | 5.95  | Adventures | Adrian  | 5.95   | 5.95  | Adventures | Adrian  | 5.95   | 5.95  | Adventures | Adrian  | 5.95   | 5.95  |
| Adventures | Adrian  | 5.95   | 5.95  | Adventures | Adrian  | 5.95   | 5.95  | Adventures | Adrian  | 5.95   | 5.95  | Adventures | Adrian  |        |       |





## HACK-FREE ZONE

There are some games that are so incredibly difficult it seems impossible that anyone could have completed them. Well, not without POKES for this and POKES for that until there's very little left of the original game! But we have a great deal of faith in the YS readership. If you've finished a game just by playing it and you're the only one you know who has, then tell us and we'll tell the world. Let's show the hackers that it can be done without rummaging around in the code.

For starters, has anyone finished *Alien 8* yet, or *Knightlore* or *Starion* or *Wiggler* or *Dragontorc* ... The list is endless, so add to it as you choose. All we ask is that you've done it without POKES or really there's no point. Sure, use them to practise tactics and pick up tips but make sure you do the final run through without.

Course, if you have cracked a game without hacking it,

**Are you hacked off with hackers? Would you have trouble hacking your own hands off? You couldn't even POKE yourself in the eye! If you play games but don't play about with them, this is the page for you. What you'll find is everything for the pure games player. So, c'mon play the game!**

you're gonna be pretty hot on the ol' hints 'n' tips. No-one's going to get round *Knightlore* without knowing just about everything there is to know on it. That's why we're asking for your expert advice as well. Tell us how it's done, what score you got and everything else of interest — help others to do what you've done and stop them from drifting off to join the mighty hordes of hackers. It's your duty as a games player!

So, fill in the coupon below and send it to **Nothing's Impossible, Your Spectrum, 14 Rathbone Place, London W1P 1DE**. Bung in a passport size piccy as well — we want to see what someone that good looks like! And finally, get someone who's seen you do it to sign the form as a verification.

Oh, and one last thing, we only want to hear from those of you who *haven't* finished *Jet Set Willy*. (Now that is impossible! Ed.)

I've done it! Though everyone said it was impossible, I finished the following game(s) and there wasn't a POKE in sight.

My name is .....

Address .....

Postcode .....

Here are some of my hints 'n' tips:

It's all true. With my own eyes I saw him/her do it.

Signed .....

# JOIN THE GANG

... In Everyone's *A Wally* from Mikro-Gen. If Wally Week and the rest of the gang are ever going to have a holiday, they've got to find the combination to the safe and earn some money. We join them after they've repaired the fountain and the pylon on the trail of the letter K.

## Overdue at the Library



Harry to find before some other doit comes and picks them up.

**Wally:** Rightio then, let's get cracking.

**Wilma Week, Wally's wife:** OK, Wally I'm just nipping off to the library to exchange my book for the jump leads.

**Wally:** Make sure you've got Book 1, Wilma, or you'll be wasting your time. And don't forget to leave the leads somewhere easy for

## Fill 'er up!



**Harry the Hippy:** Hey, wow, like heaveee man.

**Tom the Punk:** Course it's heavy, you great hairy half-wit. It's a fork-lift battery. Let me get it down, you flower-powered fool.

With a swift headbang to the battery, Tom lifts it out of the fork-lift and hands it to Harry who carts it off to the Petrol Station.

**Harry (in a really heavy scene):** Hey, I hope I've got everything man. I've got the battery and the jump leads so I'd better change it up before lugging it all the way back to Tom. Hey, this is really bad Karma!

**Tom:** 'Bout time too, I was just gonna stick a pin in ya to see if you'd died.

**Harry:** Funneee. I kept tripping over my flares, that's all!

## Building Sighs.



**Wally (whistling while he works):** It's off to work we go ... Take the bucket to the fountain and fill it, done that, get the sand and off to the cement mixer to swop it with the cement. Now where is the cement mixer?

**Dick (from the depths — well, he is a plumber):** Er, it's by the tool room, Wally. Ner, what a wally, not

knowing that!

**Wally:** I 'eard that. Rightio, where's my trowel. Oh, yes. Better go and build the wall at the building site. At least it's the easiest bit of building I'll ever do — walk past it and, hey presto, it's there.

**Harry:** Hey, Wally, I've fixed the fork-lift, man. Like crazeee. If you come and stand on the front you can walk along the wall.

**Wally:** Okey Dokey, and I can swop the cement for the letter K and, bob's yer uncle.

**And so we leave them. S'pose it's always possible that they'll get on their hols but there are still four more letters to collect, so it won't be till next winter!**

Editor Kevin Cox; Art Editor Hazel Bennington; Deputy Editor Peter Shaw; Production Editor Louise Cook; Art Assistant Martin Dixon; Editorial Consultant Andrew Pennell; Software Consultant Gavin Monk; Contributors Stephen Adams, Dave Nicholls, Roger Willis, Ross Holman, Mike Leaman, Chris Somerville, B Herival, M Rapps, M Rai, Malcolm Paknadel, Adam Leonard, Chris Wood, Craig Rawstron, Penny Page, Peter Green; Advertisement Manager David Baskerville; Production Manager Sonia Hunt; Group Advertisement Manager Jill Harris; Group Art Director Perry Neville; Art Director Jimmy Egerton; Managing Editor Roger Munford; Publisher Stephen England; Published by SportsScene Specialist Press Ltd, 14 Rathbone Place, London W1P 1DE. Telephone (all departments) 01-631 1433. Telex 8954139 BunchG. Company registered in England; Typesetters Carlinpoint, London; Reproduction Graphic Ideas, London; Printed by Chase Web Offset, St Austell, Cornwall; Distribution Seymour Press, 334 Brixton Road, London SW9. Telephone 01-733 4444. All material in *Your Spectrum* © 1985 Felden Productions, and may not be reproduced in whole or part without the written consent of the publishers. *Your Spectrum* is a monthly publication.



WIN A  
PORSCHE 924  
(or cash equivalent)  
see pack for details

• TAKE THE CHALLENGE •

# GYRON

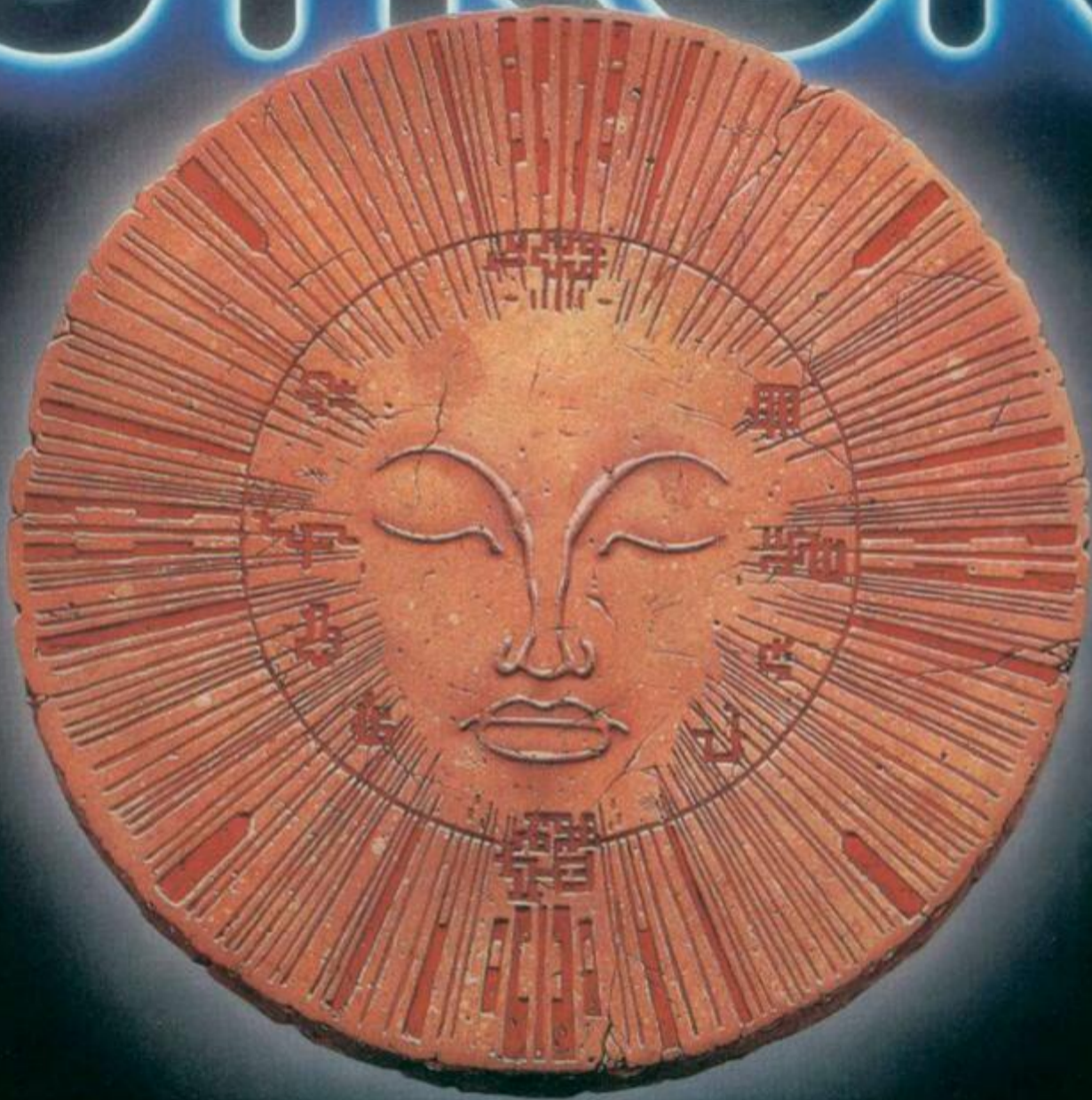

**firebird**

FIREBIRD SOFTWARE · WELLINGTON HOUSE  
UPPER ST MARTIN'S LANE · LONDON WC2H 9DL

 FIREBIRD IS A TRADEMARK OF BRITISH TELECOMMUNICATIONS PLC.

**GOLD  
EDITION**  
48K SPECTRUM · £9



# Opus.

# DISCOVERY 1

## The Dawn of a new beginning for your Spectrum

Introducing Discovery 1 – quite simply the most advanced and comprehensive disc drive unit yet developed for the Spectrum and Spectrum + computers.

Discovery is the breakthrough in design, performance and price which promises to make other Spectrum solutions obsolete. Just look at its advanced features:

- The very latest 3 1/2 inch disc drive unit
- Peripheral through connector
- Parallel printer port
- Joystick interface
- Video monitor port
- On-board power supply

**But the biggest discovery of all is the price – just £199.95**

Upgrading to a dual-drive system is simple with the 'Discovery +' upgrade package – £139.95, or choose a purpose-built twin-drive unit, 'Discovery 2' – £329.95.

#### THE DISCOVERY RANGE

- Available through the Opus dealer network nationwide – ring for your nearest stockist – or direct from Opus Supplies. For further details ring us on: 0737 65080 or post the coupon.

Please rush me the following (ALL PRICES INCLUDE VAT & CARRIAGE)  
– Discovery 1 unit(s) at £199.95 each  
– Discovery 2 unit(s) at £329.95 each

YS Ad1

I enclose a cheque for £ \_\_\_\_\_ or please debit my credit card account with the amount of £ \_\_\_\_\_

My Access  Barclaycard  (please tick) no. is \_\_\_\_\_

Name \_\_\_\_\_

Address \_\_\_\_\_

Telephone \_\_\_\_\_

**Opus.**  
Opus Supplies Ltd.

55 Ormside Way,  
Holmethorpe Industrial  
Estate, Redhill, Surrey.  
TELEPHONE: 0737-65080