



Model P-820 Cloud Point Analyzer



On-line Cloud Point Analyzer for continuous measurement of cloud point temperatures in hydrocarbons.

- ▶ Operating range -76°F to 77°F (-60°C to 25°C)
- ▶ Rapid analysis cycles of 5 minutes or less
- ▶ Does not require atmospheric recovery system
- ▶ Superior repeatability of less than 1°F (0.5°C)
- ▶ Increased reliability with operating uptime better than 99%

The Model P-820 Cloud Point Analyzer is the result of combining the latest, state-of-the-art technology with over 20 years of industry experience. The result is an unsurpassed, high-quality Cloud Point measurement system that produces the process control signal required to perform today's optimized and cost-efficient petroleum refining operations.

This compact, robust sample cell and Peltier cooling system allows captured samples to be cooled to -76°F (-60°C) with external plant water coolant. The high pressure sample cell optics allow sample extraction and return to process and pressure conditions thereby eliminating the need for atmospheric recovery.

APPLICATION

Given today's highly competitive environment, oil refiners are demanding instrumentation that aids in the optimization of the refining process. Therefore, refineries require a reliable and accurate analysis system of the Cloud Point temperature to meet the required specifications. This analysis will allow the operators to optimize the refining process and therefore lower production costs while improving product quality.

OPERATING PRINCIPLE

The P-820 measurement cycle is designed to correlate to ASTM Method D-2500 and IP-219. A near infrared fiber-optic sensing system has been employed to monitor the formation of the wax crystals during the measuring cycle cool down. The optical emitter and detectors monitor the state of the crystals through high-pressure optical windows that allow measurement cycles to occur at process pressures, eliminating the need for expensive sample recovery. The P-820 uses 0 and 90 degree optical sensors to improve accuracy and reduce errors due to entrained water or other contaminants. A state of the art Pulse Width Modulated (PWM) control of Peltier elements provides cooling power to the detection cell in the P-820. Refinery plant cooling water is passed through cooling blocks that remove the heat from the Peltier modules.

First, the P-820 measurement cycle is initiated by a sample flush through the sample detection cell. This flush time is programmable and allows fresh sample to be placed in the detection cell for the next cycle. This flush also helps to warm and dislodge any remaining wax crystals that have adhered to detection cell windows.

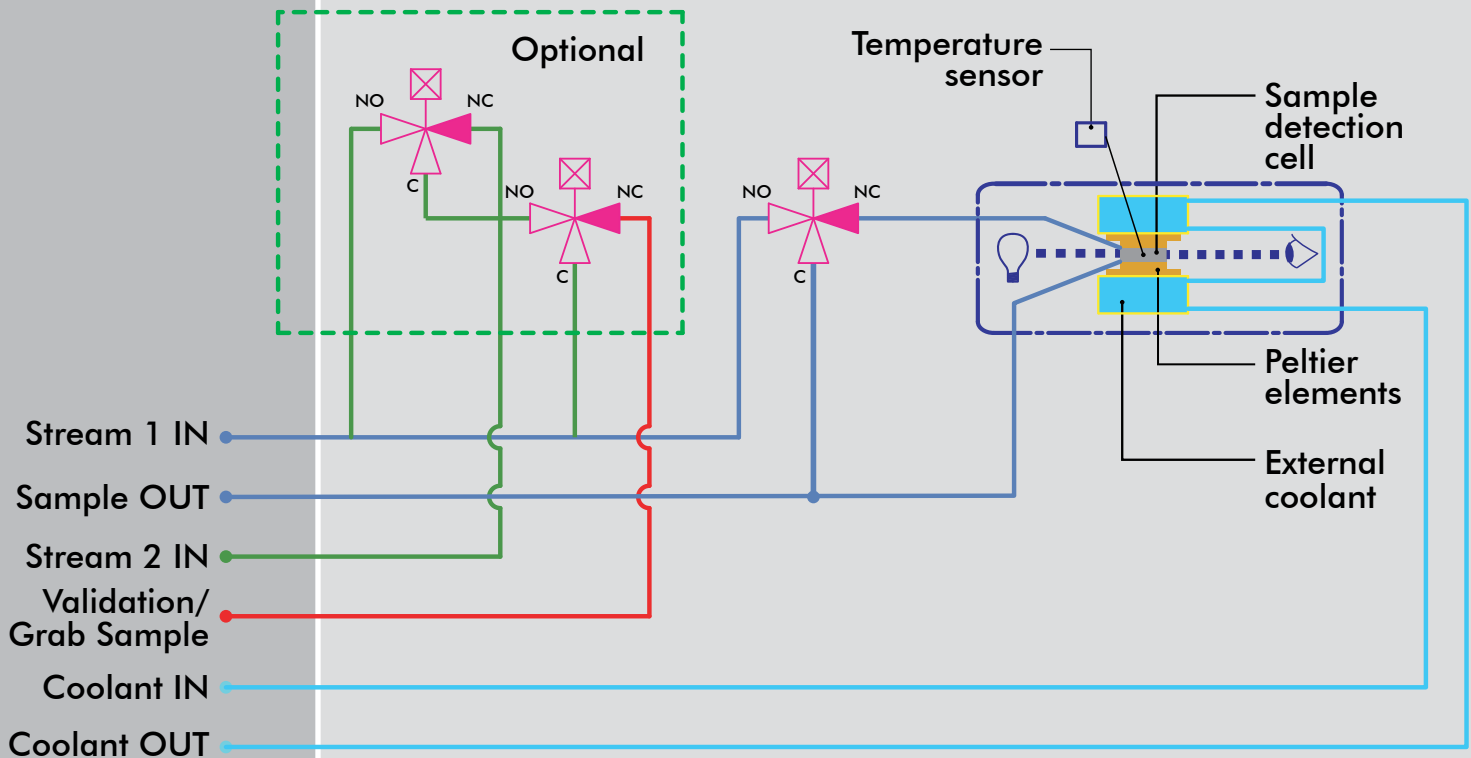

Second, the sample solenoid is closed, locking in the sample. The PWM Peltier system is then turned on to a programmed power level. This level is monitored each cycle and changed on the next cycle to maintain consistent cooling times to Cloud Point Detection. As the cooling cycle begins the temperature of the sample is monitored as well as the optical signal. The cooling power is maintained until Cloud Point is determined, the temperature at which the wax crystals form. The sample temperature at which this happens is recorded and outputted to the control room. The cycle is then repeated.

By continuously tracking the optical signal during the analysis cycle, the diagnostic function checks the fluidics system for leaks, drifts and other abnormal events. The VisioGraph advanced diagnostic routine not only provides end users with immediate knowledge of the condition of the analyzer, it also offers suggestions for troubleshooting.

To further enhance the precision and usefulness of the Model P-820 Cloud Point Analyzer, an optional validation/grab sample system can be added. This will allow the end user to either introduce a reference solution or an unknown sample for immediate analysis. This feature provides a simple system verification or a quick analysis of a non-automated sample stream. The optional dual-stream sampling system offers an economic way of automatically monitoring two sample streams with a minimal loss of measurement response time.

DIMENSIONS inch (mm)

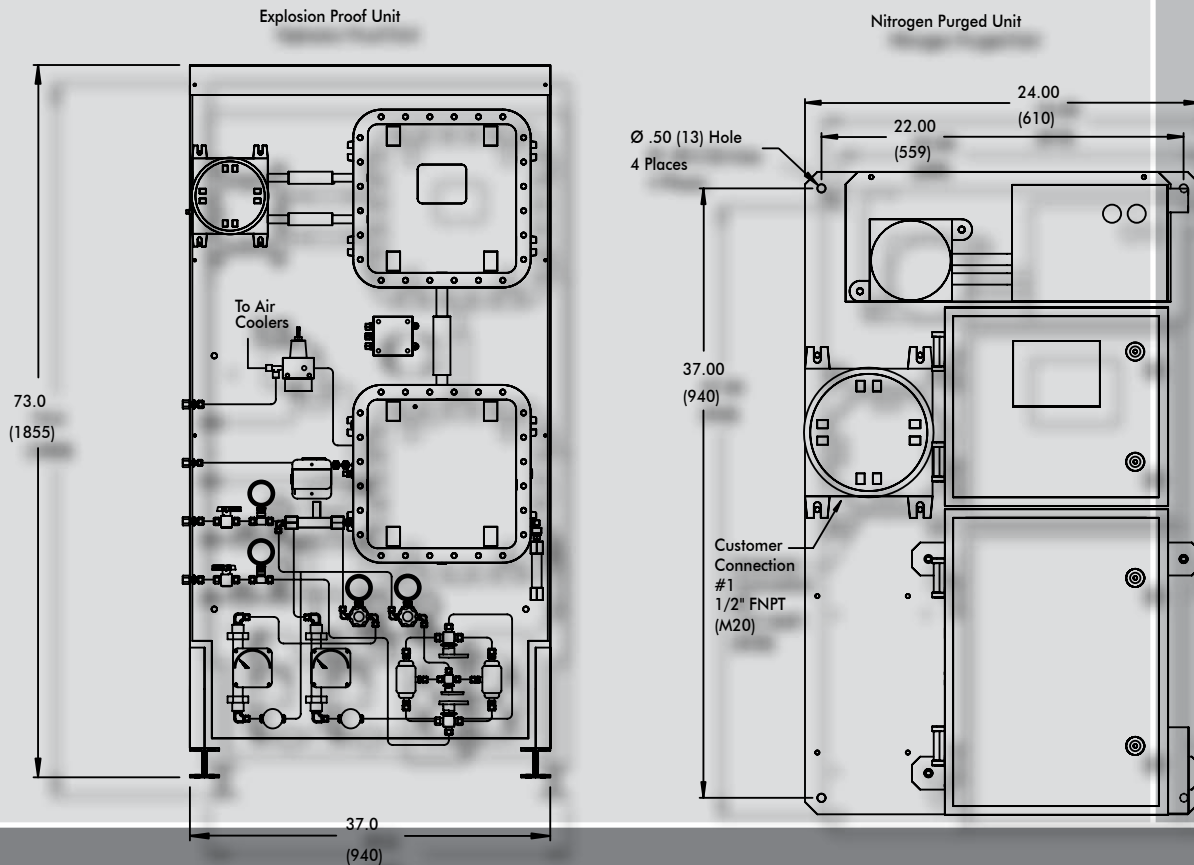



PRODUCT GUIDE

Petroleum Analyzers

- Flash Point
- Salt In Crude
- RVP
- RVP/VL20
- Freeze Point
- Cloud Point
- Pour Point
- Viscosity
- Viscosity Index

Water Analyzers

- UV-COD
- UV-Oil in Water

Other Products

- Environmental Cabinets
- Sample Conditioning Systems
- Sample Recovery Systems
- Spare Parts

Analyzer Services

- Field Service
- Start-Ups
- Training
- Technical Support



SPECIFICATIONS: P-820 CLOUD POINT ANALYZER

ANALYSIS PERFORMANCE	
Measurement Cycle Time	5 minutes or less
Measurement Range	Min. -76°F (-60°C) Max. +77°F (+25°C)
Repeatability	± 1°F (0.5°C)
Reproducibility	Meets or exceeds ASTM Method D-2500 or IP-219
Resolution	± 0.5 °F (0.25°C)
Accuracy	Meets or exceeds ASTM Method D-2500 or IP-219
Temperature Accuracy	± 1°F (0.5°C)
SAMPLE REQUIREMENTS	
Sample Flow Rate	Min. 1 L/min – Max. 2 L/min
Sample Return Pressure	Atmospheric – Max. 150 psi (10 bar)
Sample Pressure	Min. 20 psi (1.4 bar) – Max. 200 psi (14 bar)
Sample Temperature	Min. 35°F (2°C) – Max. 150°F (65°C)
Sample Particulates	less than 10 µm - optional sample conditioning system available
Sample Conditions	homogenous, single-phase sample without free water
ENCLOSURE/INSTALLATION REQUIREMENTS	
Dimensions	Width 24.0 in (610mm) – Height 39.0 in (991mm) – Depth 9.51 in (242mm)
Dimensions (Exd)	Width 37.0 in (940mm) – Height 73.7 in (1874mm) – Depth 30.0 in (762mm)
Weight	Purged Unit 150 lbs (68 kg)/ Exd Unit 500 lbs (228 kg)
Operating Temperature	Min. 40°F (5°C) – Max. 105°F (40°C)
Enclosure Material/Rating	stainless steel - NEMA 4X / IP65
Area Classification	NEC Class 1 Div 1 Group B, C + D or ATEX Zone1 II B + H2 T4
Power	self-selecting 100 to 125VAC & 200 to 240 VAC, 50/60 Hz, single phase, 10A
Cabinet Purge Gas Supply	Clean, dry Nitrogen or other inert gas (better than 98% pure) at Min. 80 psi (5.5 bar) – Max. 100 psi (6.8 bar) expected leakage compensation 1l/min
Purge System Air Logic Supply	Instrument grade air at Min. 40 psi (2.7 bar) – Max. 100 psi (6.8 bar)
Detection Cell Coolant Supply	Clean, filtered plant cooling water or a closed-loop chiller system application specific, 32°F to 104°F (0°C to 40°C) 3 liters/min
END USER CONNECTIONS	
Analog Output Signal	single isolated 4-20 mA output (optional second output available), selectable for sample Cloud Point values, analyzer system/maintenance warning or analysis measurement indication
Relay Output Contact	three SPDT Relays with contacts rated at 3A resistive load at 250VAC, selectable for sample Cloud Point value alarm, analyzer maintenance warning or analyzer fault alarm
Serial Input/Output Signal	single RS232 or RS485 bi-directional / optional ModBus output available

HOW TO ORDER

ANALYZER SYSTEMS	
Catalog Number P-820-1100	ORB Model P-820 Cloud Point Analyzer, Ex Area ready for NEC Class 1 Div 1 Group C,D
Catalog Number P-820-1200	ORB Model P-820 Cloud Point Analyzer, Ex Area ready for ATEX Zone1 II B + H2 T4
Catalog Number P-820-1400	ORB Model P-820 Cloud Point Analyzer, NEC Class 1 Div 1 Group B, C,D
OPTIONS	
Catalog Number 700474	Validation/Grab Sample System, Macro Flow
Catalog Number 700475	Dual-Stream Sampling System, Macro Flow
ACCESSORIES	
Catalog Number 700174-P820	Free-standing Mounting Rack
Catalog Number 700504	1-Year Spare Parts Kit
Catalog Number 700505	2-Year Spare Parts Kit

Lit. No. P-820-EN-US / JAN10

ORB Instruments, Inc.

4724 South Christiana
Chicago, IL 60632 / USA
Phone: + (1) 773 927-8600
Fax: + (1) 773 927-8620

Email: sales@orbinstruments.com
www.orbinstruments.com