

# The Kinematic Design of Automatic Gear Transmissions for Bicycles

Long-Chang Hsieh and Tzu-Hsia Chen

**Abstract** - Recently, bicycles are used as exercising machines and traffic vehicles. Planetary gear trains can be used as the transmission systems for bicycles. The purpose of this work is to propose a design methodology for the kinematic design of automatic gear transmissions with planetary gear trains for bicycles. First, applying the check list method (combining and extending methods), the design concepts are proposed. Then, based on the design concepts proposed and train value equation of planetary gear train, we derive the gear ratio equations of automatic three-speed gear transmissions for each invention. Three automatic three-speed gear transmissions are designed to illustrate the design methodology. Based on the proposed methodology, all automatic gear transmissions with planetary gear trains can be synthesized.

**Index Terms** - Automatic gear transmissions, check list method, kinematic design, planetary gear train.

## 1. Introduction

The bicycle is invented so far more than 200 years. Early bicycles are mankind's main tool to ride instead of walk. In recent years, because of having the advantages of light weight, cheap and pollution-free, Bicycles become the most popular traffic vehicles. They can be used as exercise machines and traffic vehicles.

The characteristics of the transmission systems are the important factors for bicycles. The transmission systems of the bicycles can be the external or internal multi-speed gear systems. The internal multi-speed gear system is also called as multi-speed gear hub. The multi-speed transmission system of a bicycle includes multi-speed gear unit, control device of changing speed, and operating device for steering control device to change speed. Figure 1 shows the multi-speed transmission system of a bicycle.

Planetary gear trains are commonly used in various transmissions due to the reason of compact size, lightweight, and multi-degrees of freedom. In general,

Manuscript received June 24, 2008. This work was supported in part by the National Science of the Republic of China for for the support of this research under NSC 94-2622-E-150-010-CC3.

Long-Chang Hsieh is with the Power Mechanical Engineering, National Formosa University, 64 Wen-Hwa Rd., Huwei, Yunlin 632, Taiwan. (Corresponding author, phone: 886-5-6315418, fax:886-5-6312110, e-mail: lochsieh@nfu.edu.tw )

Tzu-Hsia Chen is with the Mechanical and Electro-Mechanical Engineering, National Formosa University, 64 Wen-Hwa Rd., Huwei, Yunlin 632, Taiwan.. (e-mail: son.summer@msa.hinet.net )

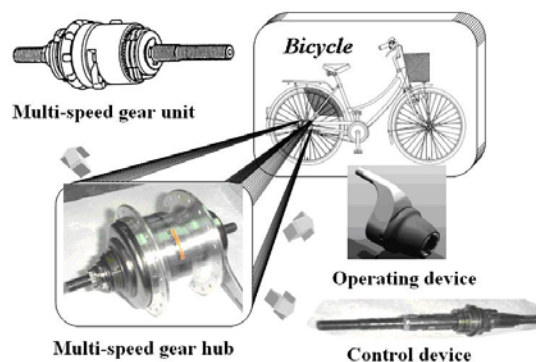

Figure 1 Multi-speed transmission system of a bicycle.

planetary gear trains used in transmission systems are planetary gear train with two degrees of freedom and with cut-joint incident to the frame [1-2]. In the past, the kinematic analysis of planetary gear trains has been the subject of a number of studies [3-9]. Some studies [10-20] focused on the kinematic design of automotive gear differentials with planetary gear trains. However, this paper focused on the kinematic design of three-speed gear transmissions for electric assisted bicycles. By referring to such related patents [21-29], the studies of kinematic analysis and design of planetary gear trains [3-20], and the studies on conceptual design of planetary gear trains [30-33], we synthesize the three-speed gear transmissions with planetary gear trains for electric assisted bicycles.

The purpose of this work is to propose a systematic approach for the kinematic design of automatic gear transmissions with planetary gear trains for bicycles.

## 2. Planetary Gear Train

A planetary gear train is a gear train contains at least one gear (planet) which is required to rotate above its own axis and another axis. A simple sun gear is a sun gear if it is adjacent to one planet only, and a simple carrier is a carrier if it is adjacent to one planet only or several serial planets. If all sun gears and all carriers are simple sun gears and simple carriers, the planetary gear train is called non-coupled planetary gear train; otherwise, it is called coupled planetary gear train. Figures 2(a) and 2(b) show the non-coupled planetary gear train and coupled planetary gear train, respectively.

### 2.1 Existing Designs

There are many multi-speed gear transmissions for bicycles. Figure 3 shows a seven-speed gear transmission

which is coupled by two planetary gear trains and design by Masashi Nagano (Shimano) in 1991. Figure 4 also shows a seven-speed gear transmission which is non-coupled planetary gear train and design by Gunter Nurberger (Fichtel & Sachs AG) in 1993.

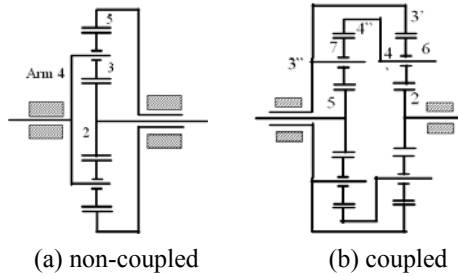
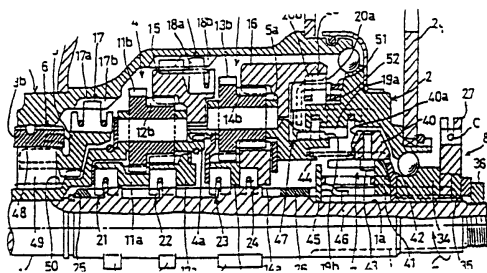
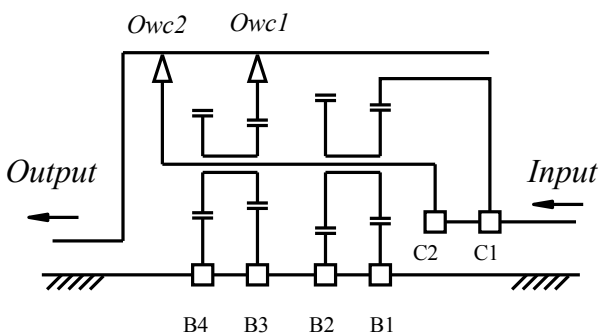

Figure 2 Planetary gear trains



(a) Structure



(b) Skelton

Gears	C1	C2	B1	B2	B3	B4	OWC1	OWC2
1st	X			X				X
2nd	X		X					X
3rd	X			X	X		X	
4th		X						X
5th	X		X		X		X	
6th		X				X	X	
7th		X			X		X	

(c) Clutch sequence

Figure 3 Self-contained change speed apparatus for use on a bicycle and having a planetary gear mechanism (US patent 5,273,500).

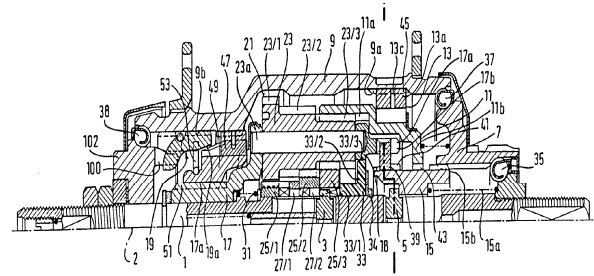

(a) Structure

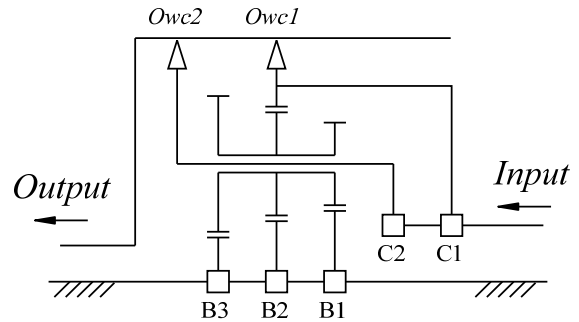

(b) Skelton

Gears	C1	C2	B1	B2	B3	OWC1	OWC2
1st	X		X				X
2nd	X			X			X
3rd	X				X		X
4th	X				X	X	
5th		X			X	X	
6th		X		X		X	
7th		X	X			X	

(c) Clutch sequence

Figure 4 Multi-speed drive hub with a separate mounting ring for the planetary gearset for bicycles (US patent 5,399,128).

### 2.2 Train Value Equation

For a train circuit of a planetary gear train, if it contains first sun gear  $i$ , last sun gear  $j$ , and carrier  $k$ , the relationship of  $\omega_i$ ,  $\omega_j$ , and  $\omega_k$  can be expressed [12-20]:

$$(1 - \xi_{ji})\omega_k = \omega_i + (-\xi_{ji})\omega_j \quad \text{for } \xi_{ji} < 0 \quad (1a)$$

$$\omega_i = \xi_{ji}\omega_j + (1 - \xi_{ji})\omega_k \quad \text{for } 0 < \xi_{ji} < 1 \quad (1b)$$

$$\xi_{ji}\omega_j = \omega_i + (\xi_{ji} - 1)\omega_k \quad \text{for } 1 < \xi_{ji} \quad (1c)$$

where  $\xi_{ji}$  is the train value of sun gear  $j$  to sun gear  $i$ . The train value  $\xi_{ji}$  be positive sign, if positive rotation of  $\omega_{ik}$  produces positive rotation of  $\omega_{jk}$ ; and  $\xi_{ji}$  be negative sign, otherwise. All coefficients of variables  $\omega_i$ ,  $\omega_j$ , and  $\omega_k$  in equations (1a)-(1c) are positive. For the planetary gear train shown in figure 2(a), train circuit 2-5-3-4-2 contains sun gear 2, sun gear 3, and carrier 4. Since train value

$\xi_{32} = -(Z_3 \times Z_5) / (Z_5 \times Z_2) < 0$ , its train value equation can be expressed as:

$$(1 - \xi_{32})\omega_4 = \omega_2 - \xi_{32}\omega_3 \quad (2)$$

### 3. Centrifugal Clutch and One-Way Clutch

Generally speaking, the automatic speed changer includes the shifting control devices (centrifugal clutches), planetary gear train, clutches (including one way clutch), brakes, and so on. The centrifugal clutch can be roughly divided into two categories: (1) radial motion centrifugal clutch, shown in Figure 5, (2) axial motion centrifugal clutch, respectively shown in Figure 6. The radial motion centrifugal clutch plays the role of engaging or divorcing by using the centrifugal block to make the radial motion, respectively shown in figures 5(b) and 5(c). The axial motion centrifugal clutch makes use of axial displacement caused by the additional weight movement, as shown in Figures 6(b) and 6(c). Due to speed change, the centrifugal clutch draws or pushes the shifting control device to realize the purpose of automatic shift. One-way clutch which consists of outer ring, rollers, inner ring, and spring (not shown). Figure 7(a) shows the structure when engaging separating, figure 7(b) and (c) are the representations of these two states.

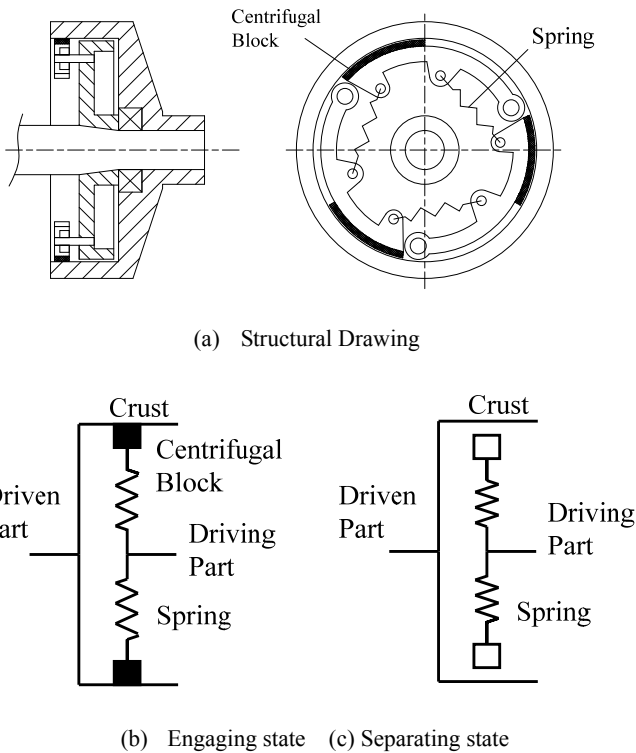

Figure 5 Radial motion centrifugal clutch

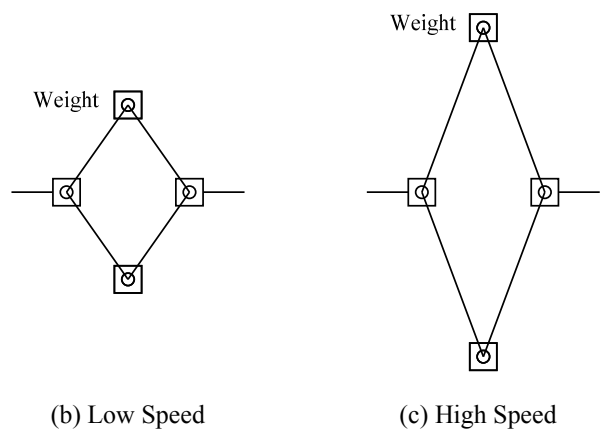
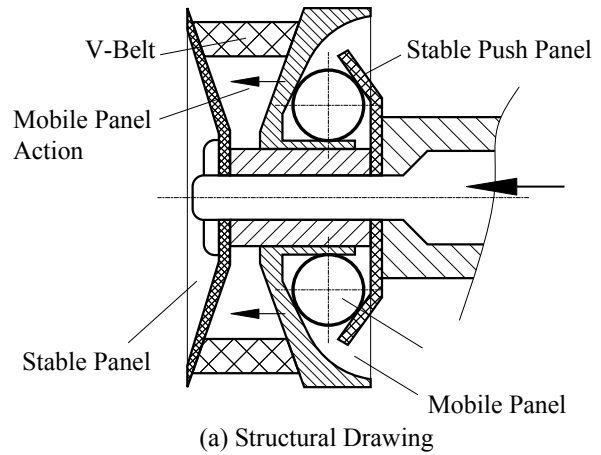

Figure 6 Axial motion centrifugal clutch

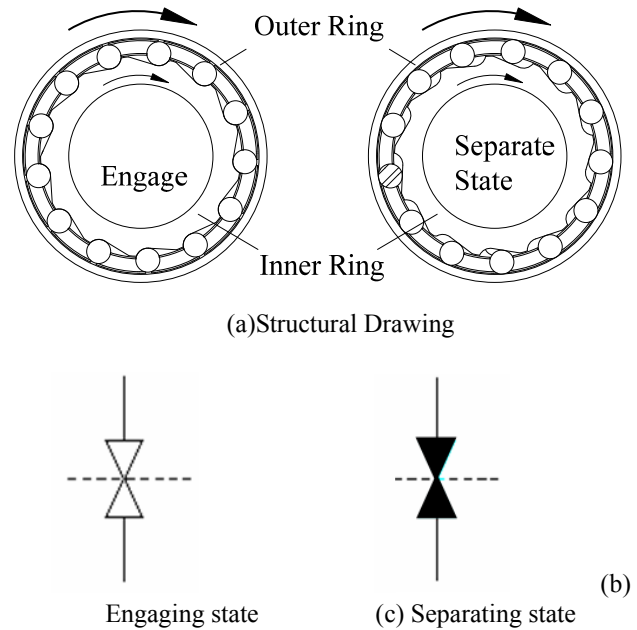

Figure 7 One-way clutch

#### 4. Automatic speed changer

The automatic speed changer can be divided into step speed changer and continuously variable speed changer. In turn the step speed changer can be divided into the fixed-axle gear type and the planetary gear type according to the gear train mechanism used in it. The automatic step speed changer uses the centrifugal clutch inducing the engine (motor) speed to change the gear position. The automatic speed changer is composed of several clutches, brakes and shifting control device and its whole operating process uses the clutch (or brake) to automatically change the reduction ratio. Thus provide the bicycle (motorcycle) with better maneuvering.

The drive system of the planetary gear type automatic speed changer is composed of planetary gear trains and several clutches (including centrifugal clutches and one-way clutches). Shown in Figure 8 is the sketch map of the planetary gear type three-speed automatic speed changer. When the engine speed reaches the preset level, the centrifugal clutch C1, one-way clutch OWC1, and one-way clutch OWC2 are engaged. The sun gear of planetary gear train is then fixed by the one-way clutch OWC1. The driving power is transmitted to the chain device via the ring gear, planet gear, and arm of the planetary gear train. It follows on the output axle via the one-way clutch OWC2 and two reduction gear sets, its reduction ratio is 22.236. With the boosting of engine speed, the centrifugal clutch C2 also engages, but the one-way clutch OWC1 separates automatically. The sun gear is then unlocked. The driving power is transmitted to the chain device via the planetary gear train, then to the output axis via the one-way clutch OWC2, and two reduction gear sets, and its reduction ratio is 13.696. If the engine speed is increased again, the centrifugal clutch C3 engages, but the one-way clutch OWC2 separates automatically. The driving power is transmitted to the chain device by the planetary gear train, then to the output axle via the centrifugal clutch C3 and two reduction gear sets, and its reduction ratio is 8.478.

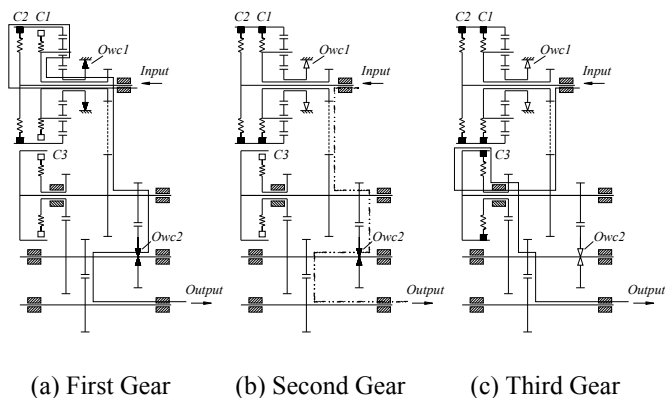

Figure 8 Existing automatic three-speed changer

#### 5. Innovation Design

In this paper, we make use of the planetary gear trains now available so as to pick out the better planetary gear trains design concepts. Also, combine with the one-way clutch and the centrifugal clutch and by apply the check list method, to conceive the creative concepts of automatic three-speed gear transmissions.

##### 5.1 Design Concepts

There are numerous design concepts of planetary gear trains, from which this paper has chosen the non-coupled planetary gear train to act as the reference basis for our design of the automatic three-speed gear transmissions for bicycles. According to the design concept of planetary gear trains conceived by Hsieh & Yan [30-33], the five planetary gear trains shown in Figure 9 are chosen. Figures 9(a) and 9(b) are five-bar planetary gear trains with two degrees of freedom, and figure 9(c), 9(d), and 9(e) are six-bar planetary gear trains with two degrees of freedom.

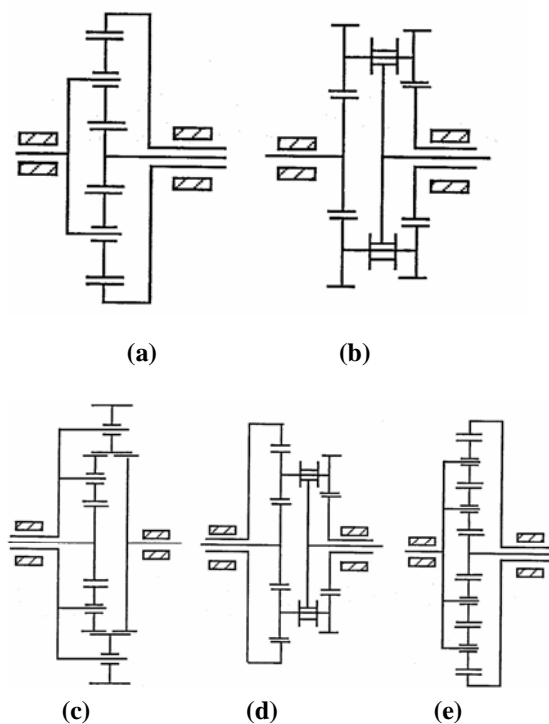

Figure 9 Five design concepts of planetary gear trains

##### 5.2 Design Constrains

After deciding on the planetary gear train, the conceptual design can be carried out on the automatic transmissions of three-speed changer. On conceiving the feasible design concept, the design constrains of the automatic transmission should be taken into consideration, so as to make the composed mechanism to meet requirements. The automatic transmission of three-speed

changer in this paper has the following design constrains:

- (1) It must possess the automatic shift function that can replace computer control, which belongs to mechanical automatic shift mechanism.
- (2) It needs to possess three-speed automatic shift function.
- (3) Its automatic internal speed changer can be divided into (a) front internal speed changer: its foot-board axle can be connected with the shift mechanism's input axle; (b) back internal speed changer: it is fixed on the central axle of back wheel.
- (4) The centrifugal clutch needs to adjust its elasticity setting value and control its tossing order.
- (5) Considering the effect of output axle, the characteristic of one-way clutch is that the fast one-way clutch acts as the output; considering the effect of input axle, the slow one-way clutch acts as the input.

### 5.3 Innovation Design

Shown in Figure 8 is the automatic three-speed changer with planetary gear train. But, in this case, only two speeds are obtained by planetary gear train. Applying the combining method of check list, we combine the centrifugal clutches, planetary gear train, and one-way clutches, shown in figure 10, to design the automatic three-speed gear transmissions. Then, by the extending method of check list, some extent change the locations of its one-way clutch and centrifugal clutch, it will enlarge the original two gear positions of the planetary gear train to a automatic three-speed gear transmissions that possesses three gear positions. Figure 11 shows the structure of automatic three-speed gear transmissions including one planetary gear train, two one-way clutches, and two centrifugal clutches.

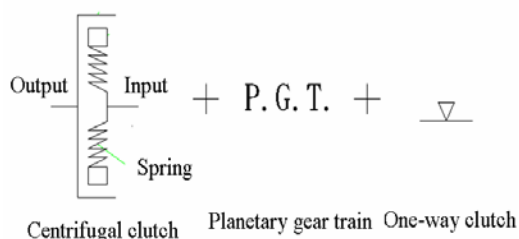

Figure 10 Concept of the invention of automatic transmission

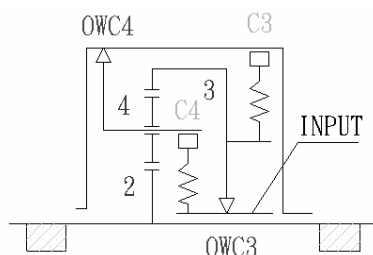

Figure 11 Automatic transmission of three-speed changer (Invention 1)

Then, according to the substituting method of check list, the planetary gear train shown in figure 11 is substituted by the planetary gear trains shown in figure 9(a) and 9(e). Two automatic three-speed gear transmissions are synthesized shown in figure 12(a) and 2(b). Each one of these two automatic three-speed gear transmissions also includes one planetary gear train, two one-way clutches, and two centrifugal clutches.



Figure 12 Automatic transmissions of three-speed changer. (Inventions 2 and 3)

### 6 Kinematic Design

By fixing the different link and collocating the one-way clutches and centrifugal clutch, we can design the automatic speed three-speed gear transmissions for bicycle.

#### 【Invention 1】

For a planetary gear train shown in figure 11, the train value  $\xi_{ji} < 0$ . According to equation (1a), we construct the gear ratio equations of planetary gear train and shown in table 1.

According to table 1, using No.5, No.7, and No.3, the three gear ratios ( $gr_1$ ,  $gr_2$ , and  $gr_3$ ) of the planetary gear trains can be expressed as:

$$gr_1 = -(1 - \xi_{32}) / \xi_{32} \quad (3)$$

$$gr_2 = 1 \quad (4)$$

$$gr_3 = -\xi_{32} / (1 - \xi_{32}) \quad (5)$$

For the change-speed transmission systems, the requirement of gear ratios is  $gr_1 / gr_2 \geq gr_2 / gr_3$ . Based on equations (3)-(5), if  $\xi_{32} = -2.5$  then  $gr_1 = 1.4$ ,  $gr_2 = 1$ , and  $gr_3 = 0.714$ .  $gr_1 / gr_2 = 1.4 \geq gr_2 / gr_3 = 1.4$ . For the Planetary gear train shown in figure 11, if  $Z_2 = 20$ ,  $Z_5 = 50$ , and  $Z_3 = 15$ , then  $\xi_{32} = -2.5$ . Figure 13 shows the corresponding three gear positions for bicycle. Table 2 shows the clutch sequence of the corresponding automatic three-speed gear transmissions.

**Table 1 Gear ratio equations of planetary gear train**

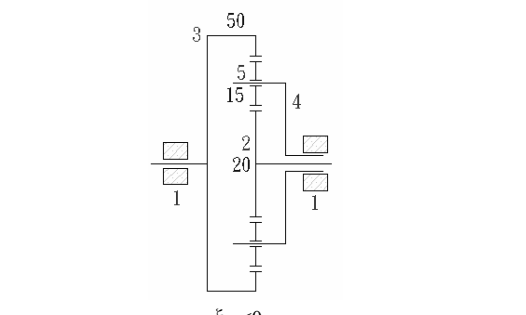

No.	In.	Fixed	Out.	Gear ratio	Dir.	Value
1	2	3	4	$1/(1-\xi_{32})$	+	0.287
2	2	4	3	$1/\xi_{32}$	-	-0.4
3	3	2	4	$-\xi_{32}/(1-\xi_{32})$	+	0.7143
4	3	4	2	$\xi_{32}$	-	-2.5
5	4	2	3	$-(1-\xi_{32})/\xi_{32}$	+	1.4
6	4	3	2	$(1-\xi_{32})$	+	3.5
7	Direct drive			1	+	1

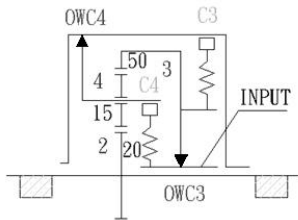

(a) First gear

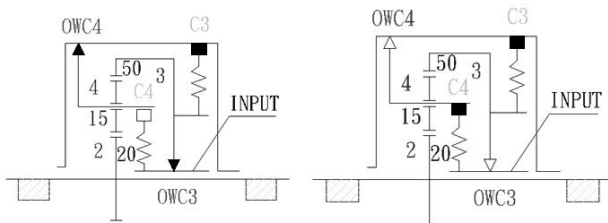

(b) Second gear

(c) Third gear

Figure 13 Three gear positions of Invention 1

**Table 2 Clutch sequence of design concept 1**

Gears	C3	C4	OWC3	OWC4	Gear ratio
1 <sup>st</sup>	Free	Free	*	*	1.4
2 <sup>nd</sup>	*		*		1
3 <sup>rd</sup>	*	*			0.714

\*: Engaged

**【Invention 2】**

For a planetary gear train shown in figure 12(a), the train value  $\xi_{ji} > 1$ . According to equation (1c), we construct the gear ratio equations of planetary gear train and shown in table 3.

**Table 3 Gear ratio equations of planetary gear train**

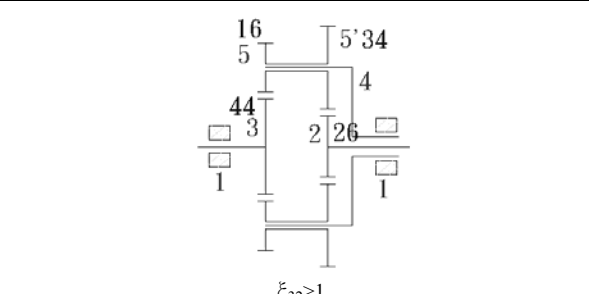

No.	In.	Fixed	Out.	Gear ratio	Dir.	Value
1	2	3	4	$-1/(\xi_{32}-1)$	-	-0.385
2	2	4	3	$1/\xi_{32}$	+	0.278
3	3	2	4	$\xi_{32}/(\xi_{32}-1)$	+	1.385
4	3	4	2	$\xi_{32}$	+	3.596
5	4	2	3	$(\xi_{32}-1)/\xi_{32}$	+	0.722
6	4	3	2	$-(\xi_{32}-1)$	-	-2.596
7	Direct drive			1	+	1

According to table 3, using No.3, No.7, and No.5, the three gear ratios ( $gr_1$ ,  $gr_2$ , and  $gr_3$ ) of the planetary gear trains can be expressed as:

$$gr_1 = \xi_{32}/(\xi_{32}-1) \tag{6}$$

$$gr_2 = 1 \tag{7}$$

$$gr_3 = (\xi_{32}-1)/\xi_{32} \tag{8}$$

For the change-speed transmission systems, the requirement of gear ratios is  $gr_1/gr_2 \geq gr_2/gr_3$ . Based on equations (6)-(8), if  $\xi_{32}=3.6$  then  $gr_1 = 1.385$ ,  $gr_2=1$ , and  $gr_3 = 0.722$ .  $gr_1/gr_2=1.385 \geq gr_2/gr_3=1.385$ . For the Planetary gear train shown in figure 12(a), if  $Z_2=26$ ,  $Z_3=44$ ,  $Z_5=16$ , and  $Z_5=34$ , then  $\xi_{32}=3.6$ . Figure 14 shows the corresponding three speed gear mechanism for bicycle. Table 4 shows the clutch sequence of the corresponding automatic three-speed gear transmissions.

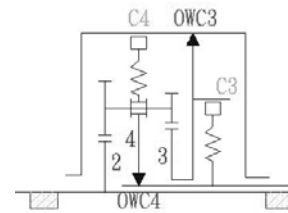

(a) First gear

Figure 14 Three gear positions of Invention 2

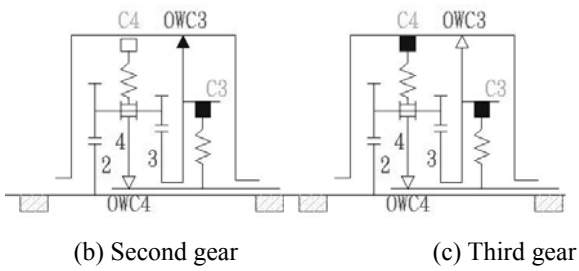

Figure 14 (Continue)

Table 4 Clutch sequence of design concept 1

Gears	C3	C4	OWC3	OWC4	Gear ratio
1 <sup>st</sup>	Free	Free	*	*	1385
2 <sup>nd</sup>	*		*		1
3 <sup>rd</sup>	*	*			0.722

\*: Engaged

**【Invention 3】**

For a planetary gear train shown in figure 12(b), the train value  $\zeta_{ji} > 1$ . According to equation (1c), we construct the gear ratio equations of planetary gear train and shown in table 5.

Table 5 Gear ratio equations of planetary gear train

No.	In.	Fixed	Out.	Gear ratio	Dir.	Value
1	2	3	4	$-1/(\zeta_{32}-1)$	-	-0.4
2	2	4	3	$1/\zeta_{32}$	+	0.286
3	3	2	4	$\zeta_{32}/(\zeta_{32}-1)$	+	1.4
4	3	4	2	$\zeta_{32}$	+	3.5
5	4	2	3	$(\zeta_{32}-1)/\zeta_{32}$	+	0.7143
6	4	3	2	$-(\zeta_{32}-1)$	-	-2.5
7	Direct drive			1	+	1

According to table 5, using No.3, No.7, and No.5, the three gear ratios ( $gr_1$ ,  $gr_2$ , and  $gr_3$ ) of the planetary gear trains can be expressed as:

$$gr_1 = \zeta_{32}/(\zeta_{32}-1) \tag{9}$$

$$gr_2 = 1 \tag{10}$$

$$gr_3 = (\zeta_{32}-1)/\zeta_{32} \tag{11}$$

For the change-speed transmission systems, the requirement of gear ratios is  $gr_1/gr_2 \geq gr_2/gr_3$ . Based on equations (9)-(11), if  $\zeta_{32}=3.5$  then  $gr_1 = 1.4$ ,  $gr_2 = 1$ , and  $gr_3 = 0.714$ .  $gr_1/gr_2 = 1.4 \geq gr_2/gr_3 = 1.4$ . For the Planetary gear train shown in figure 12(b), if  $Z_2=16$ ,  $Z_3=56$ , and  $Z_5=Z_6=15$ , then  $\zeta_{32}=3.5$ . Figure 15 shows the corresponding three speed gear mechanism for bicycle. Table 6 shows the clutch sequence of the corresponding automatic three-speed gear transmissions.

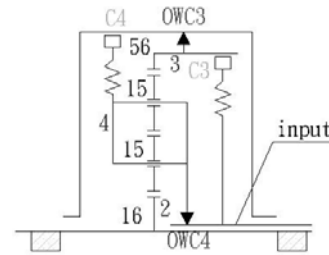

(a) First gear

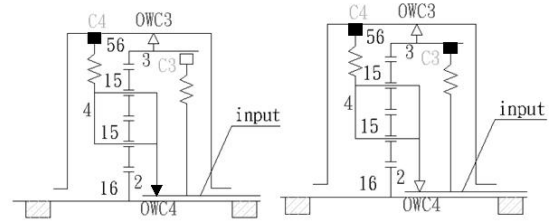

(b) Second gear

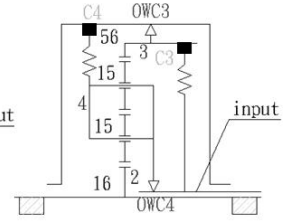

(c) Third gear

Figure 15 Three gear positions of Invention 3

Table 6 Clutch sequence of design concept 1

Gears	C3	C4	OWC3	OWC4	Gear ratio
1 <sup>st</sup>	Free	Free	*	*	1385
2 <sup>nd</sup>	*		*		1
3 <sup>rd</sup>	*	*			0.722

\*: Engaged

**7. Conclusion**

In this paper, we propose a design methodology for the kinematic design of automatic gear transmissions with planetary gear trains for bicycles. First, applying the check list method (combining and extending methods), the design concepts are proposed. Then, based on the design concepts proposed and train value equation of planetary gear train, we derive the gear ratio equations of automatic three-speed gear transmissions for each invention. Three automatic three-speed gear transmissions are designed to illustrate the design methodology. Based on the proposed methodology, all automatic gear transmissions with planetary gear trains can be synthesized. The design approach can also be used to design the more than three speed gear transmissions for bicycle.

## 8. Acknowledgements

The authors are grateful to the National Science of the Republic of China for the support of this research under NSC 94-2622-E-150-010-CC3.

## References:

- [1] L.W. Tsai, & C.C. Lin, The creation of non-fractionated two-degree-of-freedom planetary gear trains, *ASME Transactions, Journal of Mechanisms, Transmission, and Transaction in Design*, 3, 1989, 524-529.
- [2] H.S. Yan, & L.C. Hsieh, Conceptual design of gear differentials for automotive vehicles, *ASME Transactions, Journal of Mechanical Design*, 116, 1994, 565-570.
- [3] F. Freudenstein, An application of boolean algebra to the motion of planetary drives, *ASME Transactions, Journal of Engineering for Industry*, 93, 1971, 176-182.
- [4] F. Freudenstein, & A.T. Yang, Kinematics and statics of a coupled epicyclic spur gear train, *Mechanism and Machine Theory*, 7, 1972, 263-275.
- [5] L.W. Tsai, An algorithm for the kinematic analysis of epicyclic gear trains, *Proc. 9th Applied Mechanisms Conf.*, Kansas City, Missouri, Vol. 1, 1985, 1-5.
- [6] L.C. Hsieh, H.S. Yan, & L.I. Wu, An algorithm for the automotive kinematic analysis of planetary gear trains by fundamental circuit method, *Journal of the Chinese Society of Mechanical Engineers*, 10(2), 1989, 153-158.
- [7] C.H. Hsu, & K.T. Lam, A new graph representation for automatic kinematic analysis of spur-planetary gear trains, *Proc. ASME 1989 Design Automation Conf.*, Montreal, Canada, 1989, 403-408.
- [8] H.S. Yan, & L.C. Hsieh, Kinematic analysis of general planetary gear trains, *Proc. 8th World Congress on the Theory of Machines and Mechanisms*, Prague, Czechoslovakia, Vol.6, 1991, 153-157.
- [9] L.C. Hsieh, & H.S. Yan, Generalized kinematic analysis of planetary gear trains, *International Journal of Vehicle Design*, 13(5/6), 1992, 494-504.
- [10] C. Bagei, Efficient method for the synthesis of compound planetary differential gear trains for multiple speed ratio generation, and constant direction pointing chariots, *Proc. 10th Applied Mechanisms Conference*, New Orleans, Louisiana, 1987.
- [11] J.S. Freeman, & S.A. Velinsky, Comparison of the dynamics of conventional and worm-gear differentials, *ASME Transactions, Journal of Mechanisms, Transmissions, and Automation in Design*, 3, 1989, 605-610.
- [12] L.C. Hsieh, & H.S. Yan, Kinematic design of automotive gear differentials, *Journal of the Chinese Society of Mechanical Engineers*, 14(3), 1993, 240-249.
- [13] H.S. Yan, & L.C. Hsieh, Conceptual design of gear differentials for automotive vehicles, *ASME Transactions, Journal of Mechanical Design*, 116, 1994, 565-570.
- [14] L.C. Hsieh, & H.S. Yan, On the kinematic design of differential devices for full time four-wheel-drive vehicles, *International Journal of Vehicle Design*, 17(2), 1996, 182-197.
- [15] L.C. Hsieh, An efficient method for the kinematic design of coupled gear differentials for automobiles, *Journal of Applied Mechanisms and Robotics*, 4(1), 1997, 7-12.
- [16] L. C. Hsieh, On the systematic design of limited-slip spur-gear differentials with coupling type I, *Proc. 1st National Conf. on Mechanical Transmissions and Mechanisms*, Tainan, Taiwan, 1998, 227-235.
- [17] L. C. Hsieh, A method for the kinematic design of multi-speed automatic transmissions, *Proc. 10th World Congress on the Theory of Machines and Mechanisms*, Oulu, Finland, 1999, 2374-2379.
- [18] L.C. Hsieh, H.S. Lee, and M.H. Hsu, "An Approach for the Kinematic Design of Three-speed Gear Mechanisms for Electric Bicycles," Proceedings of 24<sup>th</sup> IASTED International Conference on Modeling, Identification, and Control, February 16-18, 2005, Innsbruck, Austria, 2005, pp.489-493.
- [19] Hsieh, L.C., H. S. Lee, and T.H. Chen, Lee, 2006, "An Algorithm For The Kinematic Design Of Gear Transmissions With High Reduction Ratio," Materials Science Forum, Vols. 505-507 (January 2006), pp. 1003-1008.
- [20] Hsieh L.C., Meng-Hei Hsu, and Teu-Hsia Chen, "The Design of Six-speed Gear hub for A Bicycle," Machine Design and Research, Vol.22, No.4, August 2006, pp.303-307.
- [21] Eduard Bergles, Multispeed drive hub with more than three speeds, *U.S. Patent, No.4973297*, 1990.
- [22] Masashi Nagano, Speed change hub braking construction, *U.S. Patent, No.5078644*, 1992.
- [23] William J., Automatic bicycle transmission, *U.S. Patent, No.5199929*, 1993.
- [24] Gunter Nurberger, Bicycle and bicycle with multi-speed wheel hub, *U.S. Patent, No. 5443279*, 1995.
- [25] Gerhard Meier-Burkamp, Multi-speed hub for bicycles, *U.S. Patent, No.5527230*, 1996.
- [26] Iwata, Transmission arrangement for electric power assisted bicycle, *U.S. Patent, No.5570752*, 1996.
- [27] Koshi Tabe, Automatic bicycle hub transmission using flyweights, *U.S. Patent, No.6010425*, 2000.
- [28] Marc D. Spence, Automatic bicycle transmission, *U.S. Patent, No.3995508*, 2000.
- [29] Frederic Francis Grant, Automatic transmission systems for humanly powered vehicles, *U.S. Patent, No.6354980*, 2002.
- [30] H.S. Yan, & L.C. Hsieh, Concept design of planetary gear trains for infinitely variable transmissions, *Proc. 1989 International Conf. on Engineering Design*, Harrogate, U. K., 1989, 757-766.
- [31] H.S. Yan, & L.C. Hsieh, Conceptual design of gear differentials for automotive vehicles, *ASME Transactions, Journal of Mechanical Design*, 116, 1994, 565-570.
- [32] Hsieh L.C. and H. S. Lee, "Creative Design of Three-speed Automatic Speed Changer," *The TRIZ Journal*, (2004/11).
- [33] Hsieh L.C., H. S. Lee, and Z.Y. Wang, "The Design of Planetary Gear Trains – Application of Optical Fiber Polishers," *IJMEE*, (2007/03), PP.74-92.