

# The Performance of the Output Signal of Micro Switch Group Sensor (MSGs)

K. Nishiyama, and M.C.L. Ward

**Abstract**— The strength of Micro Systems Technology (MST) is the ability to fabricate a large number of small devices economically. However such devices tend to have errors caused by the variations of fabrication and inherent noise signals such as Brownian motion or Johnson noise. This paper advances the understanding of Micro Switch Group Sensors (MSGs). In this paper, a MSGS comprising of 20 switches has been built using electronic circuits and tested to verify the performance. The output signal is compared to the number of switches turned on and analysed. The fluctuations of the output signals and the measured performance of the electrical circuit was shown to be in good agreement with the theoretical prediction. The output signal is compared to the input signal and shows that MSGS has been successfully applied as a measurement tool. Moreover the possible measurement range by using the MSGS is defined as the function of the number of switches.

**Index Terms**—Noise, Sensor, Inherent randomness, MEMS

## I. INTRODUCTION

Micro system technology (MST) has made it possible to produce micro sensors such as accelerometers and gyroscopes that are just a few hundreds of microns in size with integrated signal processing electronics [1]-[3]. While this is a marvelous achievement, the nature of the sensing element and its mode of operation have changed little compared with conventional macroscopic sensors.

Traditionally in developing a sensor system one would develop a single sensor which is both linear and devoid of any noise. For the process to be economic a large number of very small sensors should be created. This leads to the sensors becoming subject to noise such as Brownian motion and also starting to display non-linear mechanical and electrical properties [4]-[6]. There is also inherent randomness in micro sensors performance due to tolerances in the technology used to fabricate them [7]. However these features can be exploited when using MST to fabricate Micro Switch Group Sensors (MSGs).

The MSGS is a new type of sensor which measures a physical quantity by observing the state of an array of non linear switches which have an inherent randomness in their characteristics due to noise and manufacturing variability. The measurand is simply determined by observing the number of switches that are either on or off. The number can be acquired with simple digital electronic circuits, avoiding the need for a conventional A/D converter. MSGS may be regarded as a true digital sensor.

MEMS devices typically have resonant frequency of up to 100 kHz or even higher [3]. This will limit the realistic

bandwidth to a MEMS based MSGS to perhaps 50 kHz. While this is low compared to an electronic A/D converter, it is fast compared to many conventional sensors. This increase in performance occurs because small devices have much faster mechanical and thermal response times compared with conventional macroscopic devices. While each device may be a poor sensor individually, when combined in an array response times remain fast and the large number of devices provide acceptable sensor performance. MSGS may be the only way to develop wider bandwidth sensors.

In the authors previous work [8]-[10] the concept of MSGS was introduced and validated. Their studies considered a relatively small number of switches and hence could not demonstrate the full functionality of MSGS, which is very dependent upon the number of switches within the array.

In this paper the theory of MSGS is presented and validated. The device developed for this experiment is an array of electronic noise generators and comparators that have the same function as noise affected micro mechanical switches. The output signals are related to the equivalent number of switches turned on and the performance analyzed. A good agreement between the experimental data and the theoretically predicted performance was observed.

## II. THEORY OF MSGS

The principle of sensing with traditional sensors is transducing some physical quantity to an electric quantity, such as voltage, by a stand-alone sensor. The concept of MSGS is transducing the physical quantity,  $X_{in}$ , to the number of switches turned on by considering the state of the array. Making a large array of micro switches, it is possible to reduce the errors of measurement by exploiting the randomness in the devices. This is analogous to charactering a gas by its pressure rather than defining the state of each molecule.

Consider a system whereby a large number ( $N$ ) of switches can be turned on by exceeding the threshold physical quantity ( $X_{th}$ ) (the transfer function for one switch is shown in **Fig.1**).

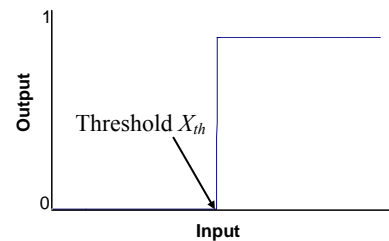

Fig.1. Transfer function

Because the dimensions of the micro switches are small they will all be affected by thermal noise and small variations in the geometry, and this will cause the thresholds to be distributed stochastically as shown in **Fig.2**.

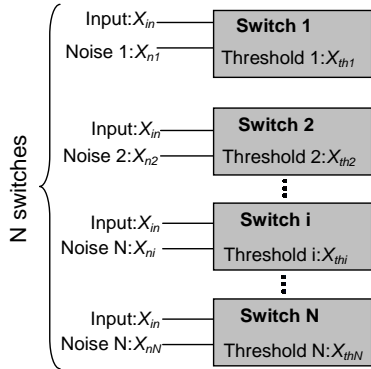

Fig.2. The illustration of MSGS

In the figure, it is assumed that  $X_{thi}$  and  $X_{ni}$  have stochastic distributions and a common input value,  $X_{in}$  is applied to each of switches. Therefore, the probability of the switch being turned on  $P_{on}(X_{in})$  is given by the cumulative distribution of the probability density as shown in **Fig.3**.

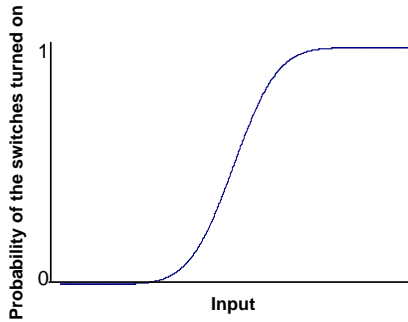

Fig.3. Probability of the switches turned on

Then the probability that  $n$  in  $N$  switches are turned on,  $P_{Nn}(X_{in})$ , is expressed by equation (1).

$$P_{Nn}(X_{in}) = {}_N C_n \times P_{on}(X_{in})^n \times \{1 - P_{on}(X_{in})\}^{N-n} \quad (1)$$

The mean value of  $X_{in}$  associated with  $n$  and  $N$ ,  $\overline{X_{in}}(N, n)$  is given as;

$$\overline{X_{in}}(N, n) = \frac{\int_{-\infty}^{\infty} P_{Nn}(X_{in}) X_{in} dX_{in}}{\int_{-\infty}^{\infty} P_{Nn}(X_{in}) dX_{in}} \quad (2)$$

It is possible to calculate the values of the input property within a tolerance being applied to the array of switches by counting the number of switches turned on. The error range cannot be determined by the states where either none or all switches are turned on. The error ranges at each state,  $\sigma_{Nn}$  are obtained by calculating the standard deviation of the probability of each state occurring,  $P_{Nn}(X_{in})$  using the following equation.

$$\sigma_{Nn} = \left[ \frac{\int_{-\infty}^{\infty} (X_{in} - \overline{X_{in}}(N, n))^2 P_{Nn}(X_{in}) dX_{in}}{\int_{-\infty}^{\infty} P_{Nn}(X_{in}) dX_{in}} \right]^{1/2} \quad (3)$$

According to the statistical method, 95.44 per cent of samples are contained in the following range.

$$\overline{X_{in}}(N, n) - 2\sigma_{Nn} \leq X_{in} \leq \overline{X_{in}}(N, n) + 2\sigma_{Nn} \quad (4)$$

For example, the mean values and their error bars for 10 and 100 switches MSGS are calculated by regarding the distribution of the errors as a standard normal distribution in **Fig. 4**.

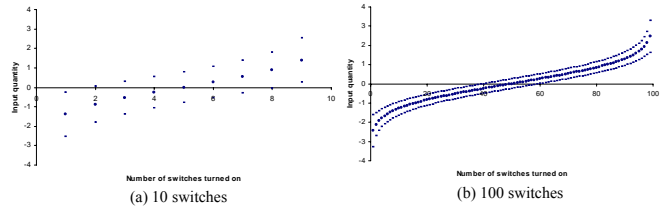

Fig.4. Mean input signal and their error

III. EXPERIMENTAL WORKS

In this experiment, a device which has the same function as MSGS was implemented using an electronic circuit. The equivalent circuit diagram for one switch is drawn in **Fig. 5**.

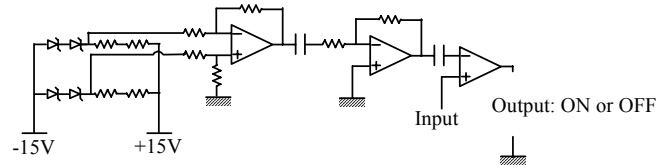

Fig. 5 Circuit diagram of the experiment device

The input voltage,  $V_{in}$  is regarded as the input signal and the noise was generated by zener diodes to make the performance of the switch stochastic. The noise signals generated by the zener diodes are amplified by operation amplifiers. The high state of a comparator is regarded to be equivalent to a switch being turned on.

The block diagram of the circuit is shown in **Fig. 6**. The Gaussian noise signal has a standard deviation  $\sigma_n$  and mean value 0, and the state of the comparator is high when the noise signal is higher than the input voltage. Then the probability that the switch is turned on by  $V_{in}$ ,  $P_{on}(V_{in})$  is given by the shaded area under the curve of the probability density of the noise signal as shown in **Fig. 7**.

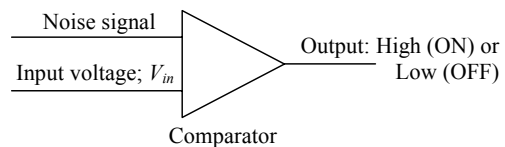

Fig.6. Block diagram of a noise affected microswitches

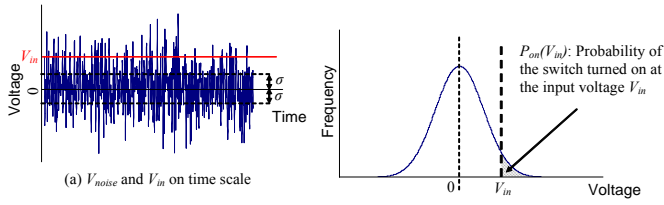

Fig.7. Probability of a switch being turned on

Hence,  $P_{on}(V_{in})$  is expressed as follows: The mean values and standard deviation of the distribution of the threshold in **Fig.2** can be regarded as zero because the offset voltages of the operation amplifiers are much smaller than the amplified noise signals.

$$P_{on}(V_{in}) = \int_{V_{in}}^{\infty} G_{sig}(V) dV = \int_{V_{in}}^{\infty} \frac{1}{\sqrt{2\pi}\sigma_n} \exp\left[-\left\{\frac{V}{\sigma_n}\right\}^2 / 2\right] dV \quad (5)$$

In this experiment, the tested numbers of switches are 5, 10 and 20. The output signal was measured for input voltages between -8V and +8V and recorded on the PC through the digital scope. The transfer function of output voltage to the number of switches turned on is given as equation (6);

$$n(V_{in}, t, N) = \frac{V_{out}(V_{in}, t, N) - V_{aloff}(N)}{V_{allon}(N) - V_{aloff}(N)} \quad (6)$$

Here,  $n(V_{in}, t, N)$  is the observed fluctuation of the number of switches turned on.  $V_{out}(V_{in}, t, N)$  is the output signal of MSGS.  $V_{allon}$  is the voltage when all the switches are on and  $V_{aloff}$  is the voltage when all the switches are off.  $V_{allon}$  and  $V_{aloff}$  can be shown to be the output voltage of 8V and -8V respectively.

IV. PERFORMANCE OF OUTPUT SIGNALS

The output signals of MSGS fluctuate as shown in **Fig. 8**. This phenomenon must be taken into consideration particularly when the stochastic nature of switching is caused by an oscillating noise signal, because it makes the probability of a switch turned on transitional. In this section, the performance of the output signal is analyzed, assuming that the switches used in the experiment are working, affected by the same intensity of noise, and have the same threshold value, zero. The probability that the switches are turned on is obtained from the experimental data and then the standard deviation of the signal is analyzed and discussed.

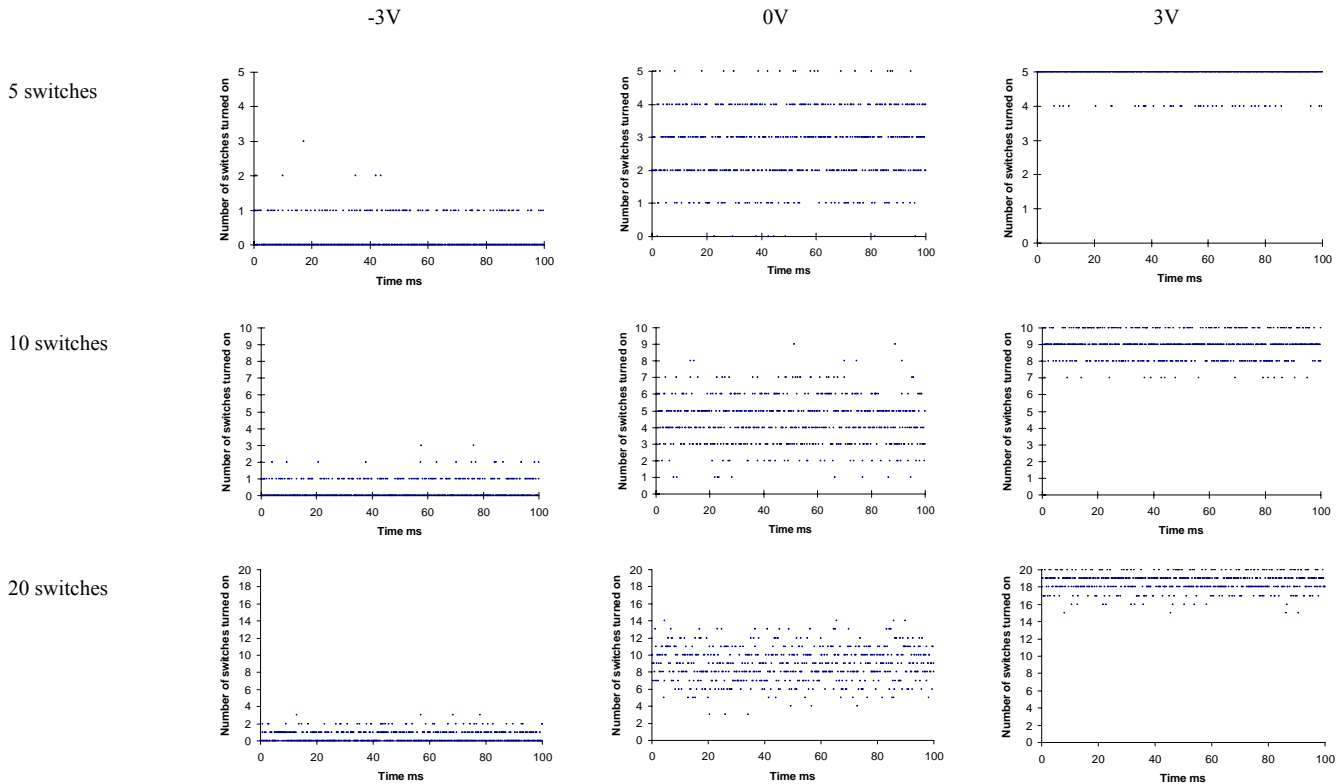

Fig.8. The probability of switches turned on

The probability of switches turned on,  $P_{on}(V_{in})$  can be obtained by using the results of experiment with the equation (7).

$$P_{on}(V_{in}) = \frac{n_{mean}(V_{in}, N)}{N} \quad (7)$$

Here,  $n_{mean}(V_{in}, N)$  is the mean value of the number of switches turned on at a input voltage  $V_{in}$ , which can be calculated by the following equation.  $T$  is the time interval of the measurement.

$$n_{mean}(V_{in}, N) = \frac{1}{T} \int_0^T n(V_{in}, t, N) dt \quad (8)$$

$P_{on}(V_{in})$  is plotted and the curve fitted by the least squares method with respect to equation(5), which is shown in **Fig.9**. The functions of the curves are used in the analysis below.

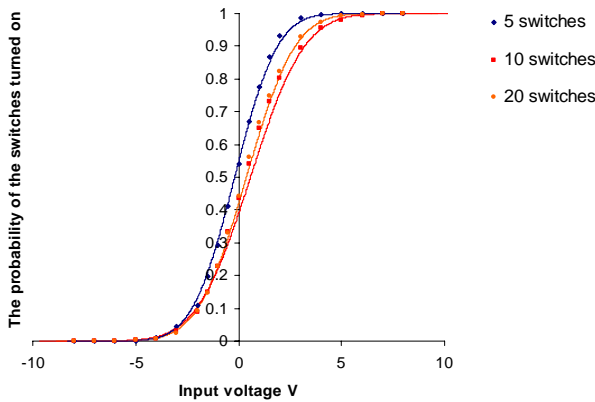

Fig.9. Standard deviations of output signals

The standard deviation of the output signal of MSGS,  $\sigma_{n(V_{in}, N)}$  can be determined statistically using the following equation;

$$\sigma_n(V_{in}, N) = \left[ \sum_{r=0}^N (r - n_{mean}(V_{in}, N))^2 P_{Nr}(V_{in}) \right]^{\frac{1}{2}} \quad (9)$$

In equation (9),  $n_{mean}(V_{in}, N)$  is derived by the equation (10).

$$n_{mean}(V_{in}, N) = NP_{on}(V_{in}) \quad (10)$$

The standard deviations of the output signals,  $\sigma_N(V_{in}, N)$ , obtained in the experiments are calculated using the following equation. In the equation  $n_{mean}(V_{in}, N)$  is obtained by using equation (8).

$$\sigma_N(V_{in}, N) = \left[ \frac{1}{T} \int_0^T \{n(V_{in}, t, N) - n_{mean}(V_{in}, N)\}^2 dt \right]^{\frac{1}{2}} \quad (11)$$

The plots obtained from experimental data and analytical results are shown in **Fig. 10**. In this figure the ratio of the standard deviation to the number of switches in the MSGS is shown for comparison. It can be seen that the fluctuation of the

signal can be reduced by increasing the number of switches. The maximum standard deviation occurs at the center of the measured range.

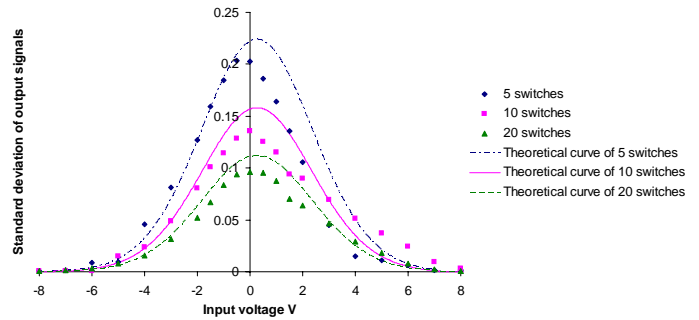

Fig.10. The fluctuation of output signal

According to the theory of MSGS, there are some states which can occur at the same input values. The largest number of states which could occur for the same input values, exist around the region where the input is 0. The fluctuation converges to zero at high or low input voltages showing that the noise becomes insignificant. Here it should be noted that these areas are caused by all or none of the switches being turned on. In this case, the actual values of the input signals are not defined; hence the states should be discarded from the output voltage while regarding the other states as useful samples.

To confirm the validity of MSGS as a measurement tool, the ratio of each of states to the output signals have been calculated. The mean values and error ranges were calculated by using equations (8)-(10). These were then plotted taking the ratio as abscisa and the error ranges as the y axis in **Fig.11**.

The input voltages are also shown for reference as a red straight line. In the figure one can observe that the values of the input signals are well in the range of the majority of the states obtained in the data. The largest number of samples is the state nearest to the mean values of the input voltage. Hence, it can be concluded that the states of MSGS can be associated with the input values and it is possible to measure them in the limited region.

It also can be seen that as the number of switches in the MSGS increases, the distribution of error ranges decrease. With the higher or lower input signals, the states which defines larger error bars are seen more often. Some samples could not be used to define the error ranges when all or none of the switches are turned on, however the fluctuation of the output signal discussed above is smaller.

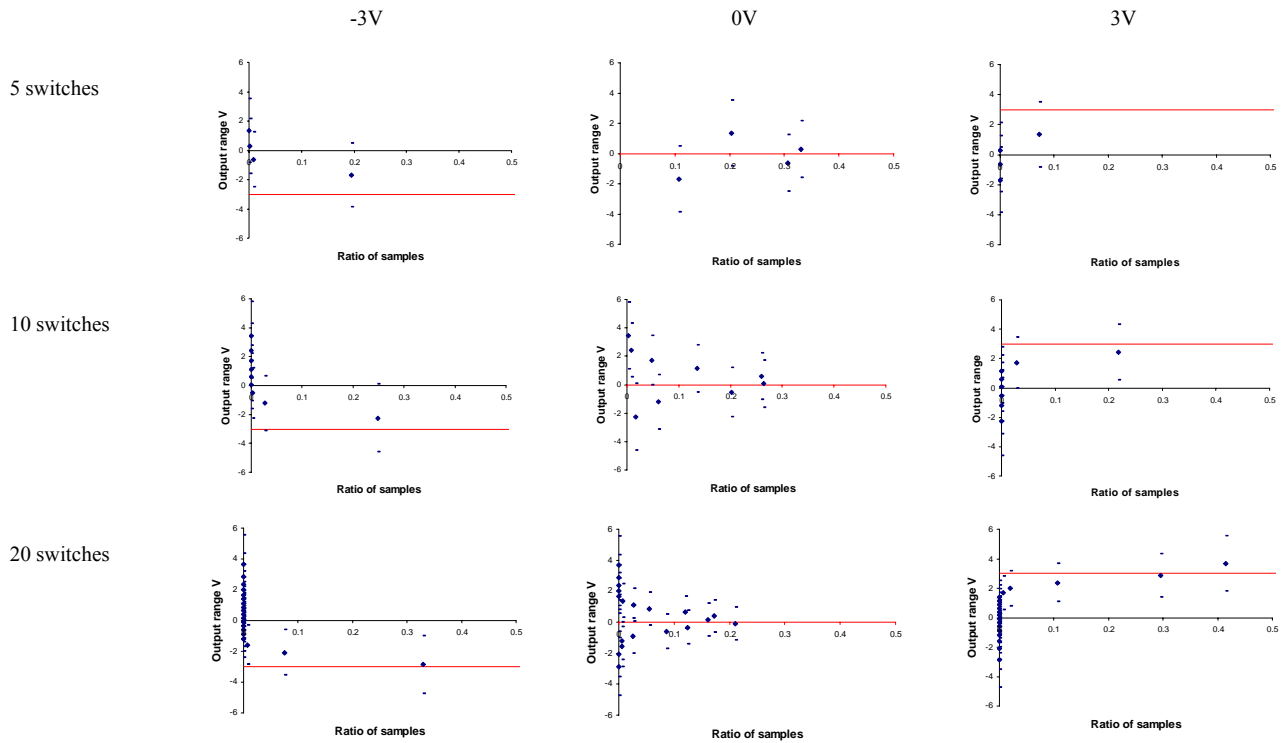

Fig.11. The validation of measurement

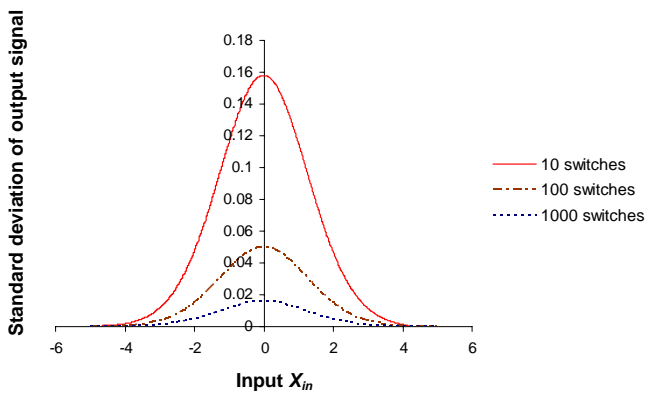

Fig.12. The fluctuation of output signal

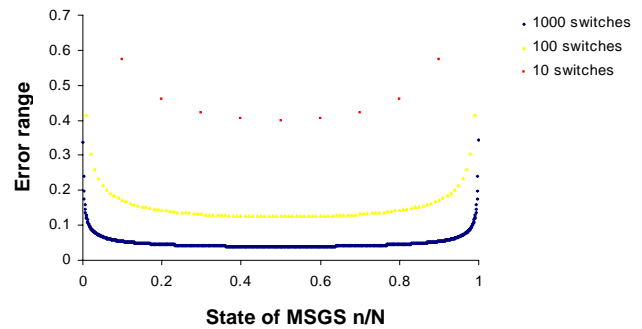

Fig.13. The transition of the size of error ranges

In **Fig.12** the magnitude of the output signal fluctuations for 10, 100, 1000 switch MSGS is shown. The error ranges of those numbers of MSGS,  $\sigma_{Nn}$  are shown in **Fig.13**. To obtain those figures it was assumed that the noise signal has a standard normal distribution. It can be seen that when the number of switches increases both of the fluctuation and the error becomes much smaller. Thus it can be concluded that more accurate measurements can be performed with larger numbers of switches.

In addition to the discussions so far, one would notice that when high or low input signal is applied to the system, there are higher probabilities that all or none of switches turned on, which do not define the variation of the input physical quantity. Then, the region where these states are expected not to be observed defines the possible measurement range of the MSGS. Equation (12) calculates the probability that the states, all or none of switches turned on, do not occur,  $P_{1,N-1}(X)$ .

$$P_{1,N-1}(X) = 1 - (P_{NN}(X) + P_{N0}(X)) \quad (12)$$

We define the region of  $X$  where  $P_{1,N-1}(X)$  is more than 0.99 as the useful measurement region of the MSGS with the useful states. The region calculated by assuming the numbers of switches in the MSGS are 16, 64, 256 and 1024 switches MSGS are shown in **Fig.14** respectively. It can be seen that these regions become wider with larger number of switches in the MSGS.

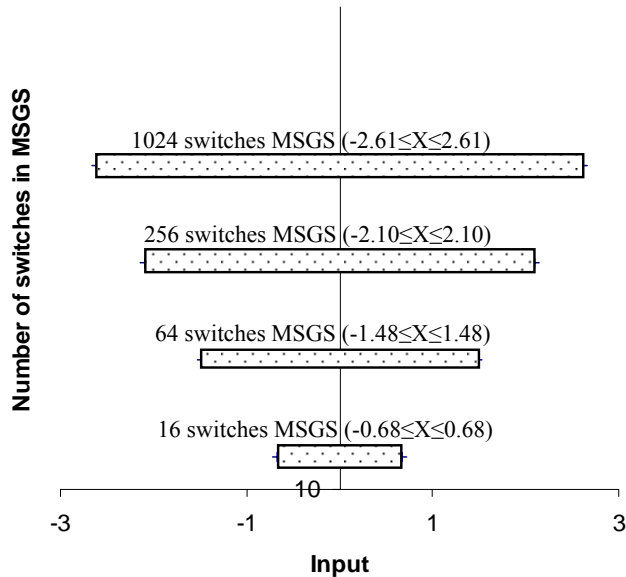

Fig.14 The useful measurement region of MSGS

## I. CONCLUSION

In this paper, the performance of MSGS is observed and analyzed taking the fluctuation of the signals into consideration. In the experiment, MSGS with 5, 10 and 20 switches were modeled using electronic circuits. The output signals were compared to the number of switches turned on and analyzed. There was a good agreement between the data obtained and the performance predicted by the theory. The output signals in the dimension of the number of switches turned on are compared to the mean value and their error ranges. According to the results we can conclude that it is possible to measure the value of a physical quantity by applying the theory of MSGS. It has been shown that MSGS with larger numbers of switches enables more accurate measurements. Then the range where the measurement can be performed is defined as the function of the number of switches in the MSGS.

## REFERENCES

- [1] J.W. Gardner, V.K. Varadan, O.O. Awadelkarim, "Microsensors MEMS and Smart Devices", John Wiley & Sons, LTD, 047186109, (2001) pp. 1-8
- [2] B. Kloek and N.F. De Rooij, "Semiconductor Sensors", S.M. Sze, 0471546097 (1994) Chap1
- [3] M. Elwenspoek, R. Wiegerink, "Mechanical Microsensors" Springer, 3540675825, (2000) Chapter.3, 5
- [4] J.R. Vig, Y. Kim, "Noise in Microelectromechanicalsystem Resonators", IEEE Transactions on Ultrasonics, Ferroelectrics, and Frequency Control, 46, No.6, November (1999) pp.1558-1565
- [5] D. Huber, P. Corredoura, S. Lester, V. Robbins, L. Kamas, "Reducing Brownian Motion in an Electrostatically Tunable MEMS Laser", Journal of Microelectromechanical Systems, 13, No.5, October (2004), pp. 732-736
- [6] T.B. Gabrielson, "Mechanical-Thermal Noise in Micromachined Acoustic and Vibration sensors", IEEE Transaction of Electron Devices, 40, May (1993) pp. 903-909
- [7] R. Liu, P. Paden, K. Turner "Process-Induced Feature Width Variations" Journal of Microelectromechanical Systems", 11, No.5, October (2002), pp. 505-511
- [8] K. Nishiyama, M.C.L. Ward, R.K.AL-Dadah, "Group sensor method with statistics", Sensors & Actuators: A. Physical, in the press
- [9] K. Nishiyama, M.C.L. Ward, R.K.AL-Dadah, "Application of the Theory of Micro Switch Group Sensor (MSGS) to Noise-Affected Switches", Sensors & Actuators: A. Physical, to be published
- [10] K. Nishiyama, M.C.L. Ward, R.K.AL-Dadah, "Theory and Experimental Verification of Micro Switch Group Sensor (MSGS)", Physica status solidi, to be published