

---

# ACFlow: Flow Models for Arbitrary Conditional Likelihoods

---

Yang Li<sup>1</sup> Shoaib Akbar<sup>2</sup> Junier B. Oliva<sup>1</sup>

## Abstract

Understanding the dependencies among features of a dataset is at the core of most unsupervised learning tasks. However, a majority of generative modeling approaches are focused solely on the joint distribution  $p(x)$  and utilize models where it is intractable to obtain the conditional distribution of some arbitrary subset of features  $x_u$  given the rest of the observed covariates  $x_o$ :  $p(x_u | x_o)$ . Traditional conditional approaches provide a model for a *fixed* set of covariates conditioned on another *fixed* set of observed covariates. Instead, in this work we develop a model that is capable of yielding *all* conditional distributions  $p(x_u | x_o)$  (for arbitrary  $x_u$ ) via tractable conditional likelihoods. We propose a novel extension of (change of variables based) flow generative models, arbitrary conditioning flow models (ACFlow). ACFlow can be conditioned on arbitrary subsets of observed covariates, which was previously infeasible. We further extend ACFlow to model the joint distributions  $p(x)$  and arbitrary marginal distributions  $p(x_u)$ . We also apply ACFlow to the imputation of features, and develop a unified platform for both multiple and single imputation by introducing an auxiliary objective that provides a principled single “best guess” for flow models. Extensive empirical evaluations show that our model achieves state-of-the-art performance in modeling arbitrary conditional distributions in addition to both single and multiple imputation in synthetic and real-world datasets.

## 1. Introduction

Spurred on by recent impressive results, there has been a surge in interest for generative probabilistic modeling in ma-

---

<sup>1</sup>Department of Computer Science, University of North Carolina at Chapel Hill, NC, USA <sup>2</sup>Department of Mathematics, North Carolina State University, NC, USA. Correspondence to: Yang Li <yangli95@cs.unc.edu>.

chine learning. These models learn an approximation of the underlying data distribution and are capable of drawing realistic samples from it. Generative models have a multitude of potential applications, including image restoration (Ledig et al., 2017), agent planning (Houthoofd et al., 2016), and unsupervised representation learning (Chen et al., 2016).

Most generative approaches are solely focused on the joint distribution of features,  $p(x)$ , and are opaque in the conditional dependencies that are carried among subsets of features. Existing conditional generative models are mostly conditioned on a fixed set of covariates, such as class labels (Kingma & Dhariwal, 2018) or other data points (Li et al., 2019b). In this work, we propose a framework, arbitrary conditioning flow models (ACFlow), to construct generative models that yield tractable (analytically available) conditional likelihoods  $p(x_u | x_o)$  of an arbitrary subset of covariates,  $x_u$ , given the remaining observed covariates  $x_o$ . Although the complete data  $x$  comes from a certain distribution, all its conditional distributions  $p(x_u | x_o)$  vary when conditioned on different  $x_o$ , which poses challenges for modeling the highly multimodal distributions. Furthermore, the dimensionality of  $x_u$  and  $x_o$  could be arbitrary.

Dealing with arbitrary dimensionality is a largely unexplored topic in current generative models. One might want to explicitly learn a separate model for each different subset of observed covariates; however, this approach quickly becomes infeasible as it requires an exponential number of models with respect to the dimensionality of the input space. In this work, we propose several conditional transformations that handle arbitrary dimensionality in a principled manner and further combine them with an autoregressive likelihood approach for flexible, tractable generative modeling.

In addition, ACFlow can handle the joint distribution  $p(x)$  and arbitrary marginal distributions  $p(x_u)$  as special cases. Joint distribution  $p(x)$  can be obtained by conditioning on an empty set, i.e.,  $p(x | \emptyset)$ , while arbitrary marginal distribution  $p(x_u)$  can be obtained similarly as  $p(x_u | \emptyset)$ . In effect, this allows for our model to perform arbitrary marginalization, which has previously been infeasible in flow models and autoregressive frameworks.

Besides computing likelihoods, we also explore the use of ACFlow for imputation, where we infer possible values of  $x_u$ , given observed values  $x_o$  both in general real-valued

data and images (for inpainting). From the perspective of probabilistic modeling, data imputation attempts to learn a distribution of the unobserved covariates,  $x_u$ , given the observed covariates,  $x_o$ . Thus, generative modeling is a natural fit for data imputation. It handles single imputation and multiple imputation in an unified framework by allowing the generation of an arbitrary number of samples. More importantly, it quantifies the uncertainty in a principled manner.

Our contributions are as follows. 1) We propose a novel extension of flow-based generative models to model the conditional distribution of arbitrary unobserved covariates. Our method is the first to develop invertible transformations that operate on an arbitrary set of covariates. 2) We strengthen a flow-based model by using a novel autoregressive conditional likelihood. 3) We propose a novel penalty to generate a single imputed “best guess” for models without an analytically available mean. 4) We extend ACFlow to model arbitrary marginals, enabling one to do approximate marginalization of flow models, which was previously infeasible. 5) We run extensive empirical studies and show that ACFlow achieves state-of-the-art arbitrary conditional likelihoods on benchmark datasets.

## 2. Problem Formulation

Consider a real-valued<sup>1</sup> distribution  $p(x)$  over  $\mathbb{R}^d$ . We are interested in estimating the conditional distribution of *all* possible subsets of covariates  $u \subseteq \{1, \dots, d\}$  conditioned on the remaining observed covariates  $o = \{1, \dots, d\} \setminus u$ . That is, we shall estimate  $p(x_u | x_o)$  where  $x_u \in \mathbb{R}^{|u|}$  and  $x_o \in \mathbb{R}^{|o|}$ , for all possible subsets  $u$ .

For ease of notation, let  $b \in \{0, 1\}^d$  be a binary mask indicating which dimensions are observed. Furthermore, let  $v[b]$  index a vector  $v$  using a bitmask  $b$ . Thus,  $x_o = x[b]$  denotes observed dimensions and  $x_u = x[1 - b]$  denotes unobserved dimensions. We also apply this indexing mechanism to matrices such that  $W[b, b]$  indexes rows and then columns. Without loss of generality, conditionals may also be conditioned on the bitmask  $b$ ,  $p(x_u | x_o, b)$ , and will be estimated with maximum log-likelihood estimation as described below. In addition, imputation tasks shall be accomplished by generating samples from the conditional distributions  $p(x_u | x_o, b)$ .

## 3. Background

ACFlow builds on Transformation Autoregressive Networks (TANs) (Oliva et al., 2018), a flow-based model that combines transformation of variables with autoregressive likelihoods. We expound on flow-based models and TANs below.

<sup>1</sup>Data with categorical dimensions can be handled by a special case of our model, please refer to appendix A.

The change of variable theorem (1) is the cornerstone of flow-based generative models, where  $q$  represents an invertible transformation that transforms covariates from input space  $\mathcal{X}$  into a latent space  $\mathcal{Z}$ .

$$p_{\mathcal{X}}(x) = \left| \det \frac{dq}{dx} \right| p_{\mathcal{Z}}(q(x)) \quad (1)$$

Typically, a flow-based model transforms the covariates to a latent space with a simple base distribution, like a standard Gaussian. However, TANs provide additional flexibility by modeling the latent distribution with an autoregressive approach (Larochelle & Murray, 2011). This alters the earlier equation (1), in that  $p_{\mathcal{Z}}(q(x))$  is now represented as the product of  $d$  conditional distributions.

$$p_{\mathcal{X}}(x) = \left| \det \frac{dq}{dx} \right| \prod_{i=1}^d p_{\mathcal{Z}}(z^i | z^{i-1}, \dots, z^1) \quad (2)$$

Since flow models give the exact likelihood, they can be trained by directly optimizing the log likelihood. In addition, thanks to the invertibility of the transformations, one can draw samples by simply inverting the transformations over a set of samples from the latent space.

## 4. Methods

We develop ACFlow by constructing both conditional transformations of variables and autoregressive likelihoods that work with an arbitrary set of unobserved covariates. To deal with arbitrary dimensionality for conditioning covariates  $x_o$ , we define a zero imputing function  $\phi(x_o; b)$  that returns a  $d$ -dimensional vector by imputing vector  $x_o \in \mathbb{R}^{|o|}$  with zeros based on the specified binary mask  $b$ :

$$w = \phi(x_o; b), \quad w_i = \begin{cases} x_o[c_i], & b_i = 1 \\ 0, & b_i = 0 \end{cases} \quad (3)$$

where  $c_i = \sum_{j=1}^i b_j$  represents the cumulative sum over  $b$ . The imputed output  $w$  is a  $d$ -dimensional vector with unobserved values replaced by zeros (See Fig. 1(a) for an illustration.). Thus, we get a conditioning vector with fixed dimensionality. However, handling the arbitrary dimensionality of  $x_u$  requires further care, as discussed below.

### 4.1. Arbitrary Conditional Transformations

We first consider a conditional extension to the change of variable theorem:

$$p_{\mathcal{X}}(x_u | x_o, b) = \left| \det \frac{dq_{x_o, b}}{dx_u} \right| p_{\mathcal{Z}}(q_{x_o, b}(x_u) | x_o, b), \quad (4)$$

where  $q_{x_o, b}$  is a transformation on the unobserved covariates  $x_u$  with respect to the observed covariates  $x_o$  and binary mask  $b$  as demonstrated in Fig. 1(a). However, the fact that

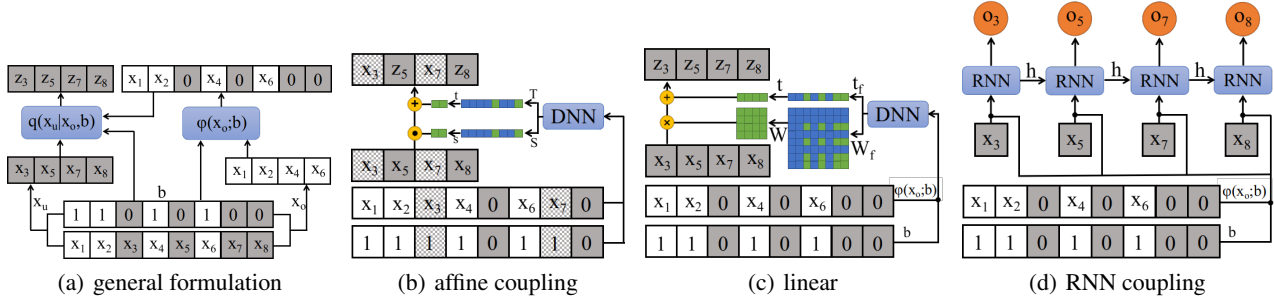

Figure 1. Conditional transformations used in ACFlow. Grayed out boxes represent unobserved covariates. Checkerboarded boxes in (b) belong to unobserved dimensions, but are used as conditioning in the affine coupling transformation.

$x_u$  is a set of arbitrary missing dimensions makes it challenging to define  $q_{x_o, b}$ 's across different bitmasks  $b$ . One challenge comes from requiring the transformation to have adaptive outputs that can adapt to different dimensionality of  $x_u$ . Another challenge is that different missing patterns require the transformation to capture different dependencies. Since the missing pattern could be arbitrary, we require the transformation to learn a large range of possible dependencies. To solve those challenges, we propose several conditional transformations that leverage the conditioning information in  $x_o$  and  $b$  and can be adapted to arbitrary  $x_u$ . We describe them in detail below. For notation simplicity, we drop the subscripts  $\mathcal{X}$  and  $\mathcal{Z}$  in the following sections.

**Affine Coupling Transformation** Affine coupling is a commonly used flow transformation. Here, we derive a arbitrary conditional version. Just as in the unconditional counterparts (Dinh et al., 2014; 2016; Kingma & Dhariwal, 2018), we divide the unobserved covariates  $x_u$  into two parts,  $x_u^A$  and  $x_u^B$  according to some binary mask  $b_u \in \{0, 1\}^{|u|}$ , i.e.,  $x_u^A = x_u[b_u]$  and  $x_u^B = x_u[1 - b_u]$ . We then keep the first part  $x_u^A$  and transform the second part  $x_u^B$ , i.e.,

$$\begin{aligned} x_u^A &= x_u^A \\ x_u^B &= x_u^B \odot s(x_u^A, b_u, x_o, b) + t(x_u^A, b_u, x_o, b), \end{aligned} \quad (5)$$

where  $\odot$  represents the element-wise (Hadamard) product.  $s$  and  $t$  computes the scale and shift factors as the function of both observed covariates and covariates in group A. Note that both inputs and outputs of  $s$  and  $t$  contain arbitrary dimensional vectors. To deal with arbitrary dimensionality in inputs, we apply the zero imputing function (3) to  $x_u^A$  and  $x_o$  respectively to get two  $d$ -dimensional vectors with missing values imputed by zeros. We also apply  $\phi$  to  $b_u$  to get a  $d$ -dimensional mask. The shift and scale functions  $s$  and  $t$  are implemented as deep neural networks (DNN) over  $x_c = \phi(\phi(x_u^A, b_u); 1 - b) + \phi(x_o, b)$  and  $b_c = \phi(b_u; 1 -$

$b) + b$ , i.e.,

$$\begin{aligned} S &= \text{DNN}(\text{concat}(x_c, b_c)) \in \mathbb{R}^d, \\ T &= \text{DNN}(\text{concat}(x_c, b_c)) \in \mathbb{R}^d, \end{aligned} \quad (6)$$

where  $\text{concat}$  defines a concatenate function and the two DNN functions can share weights.

The outputs of  $s$  and  $t$  need to be adaptive to the dimensions of  $x_u^B$ , thus we apply the indexing mechanism,  $[\cdot]$ , that takes the corresponding dimensions of non-zero values with respect to binary masks  $1 - b$  and  $1 - b_u$ , i.e.,

$$\begin{aligned} s &= S[1 - b][1 - b_u], \\ t &= T[1 - b][1 - b_u]. \end{aligned} \quad (7)$$

A visualization of this transformation is presented in Fig. 1(b). Note that the way we divide  $x_u$  might depend on our prior knowledge about the data correlations. For image data, we use checkerboard and channel-wise split as in (Dinh et al., 2016). For real-valued vectors, we use even-odd split as in (Dinh et al., 2014).

**Linear Transformation** Another common transformation for flow-based models is the linear transformation. Contrary to the coupling transformation that only leverages correlation between two separated subsets, the linear transformation can take advantage of correlation between all dimensions. Furthermore, the linear transformation can be viewed as a generalized permutation which rearranges dimensions so that next transformation can be more effective.

In order to transform  $x_u$  linearly, we would like to have an adaptive weight matrix  $\mathbf{W}$  of size  $|u| \times |u|$  and a bias vector  $t$  of size  $|u|$ . Similar to the affine coupling described above, we first apply a deep neural network over  $\phi(x_o; b)$  and binary mask  $b$  to get a  $d \times d$  matrix  $\mathbf{W}_f$  and a  $d$ -dimensional bias vector  $t_f$ , then we index them with respect to the binary

mask  $1 - b$ , i.e.,

$$\begin{aligned} \mathbf{W}_f &= \text{DNN}(\phi(x_o; b), b) \in \mathbb{R}^{d \times d}, \\ \mathbf{W} &= \mathbf{W}_f [1 - b, 1 - b] \in \mathbb{R}^{|u| \times |u|}, \\ t_f &= \text{DNN}(\phi(x_o; b), b) \in \mathbb{R}^d, \\ t &= t_f [1 - b] \in \mathbb{R}^{|u|}. \end{aligned} \quad (8)$$

The linear transformation can then be derived as  $z_u = \mathbf{W}x_u + t$ . Fig. 1(c) illustrates this transformation over an 8-dimensional example. In practice, we add another learnable full-rank weight matrix to  $W_f$  to guarantee invertibility.

In order to decrease complexity, it is straightforward to parametrize  $W_f$  with rank  $r$  matrices by taking the product of two rank  $r$  matrices with size  $d \times r$  and  $r \times d$  respectively. Hence, the DNN can reduce its output dimensions to  $2dr$ . During preliminary experiments, we observed minimal drop in performance when using a large enough  $r$ .

**RNN Coupling Transformation** The affine coupling transformation can be viewed as a rather rough recurrent transformation with only one recurrent step. We can generalize it by running an RNN over  $x_u$  and transform each dimension sequentially (shown in Fig.1(d)). Note that a recurrent transformation naturally handles different dimensionality. To leverage conditioning inputs  $x_o$  and  $b$ , we concatenate  $\phi(x_o; b)$  and  $b$  to each dimension of  $x_u$ . The outputs of the RNN are used to derive the shift and scale parameters respectively.

$$\begin{aligned} o^i, h^i &= \text{RNN}(\text{concat}(x_u^{i-1}, \phi(x_o; b), b), h^{i-1}), \\ z_u^i &= x_u^i * s(o^i) + t(o^i), \end{aligned} \quad (9)$$

where  $x_u^0 = -\mathbf{1}$ ,  $h^0 = \mathbf{0}$ , and  $i$  indexes through dimensions.

**Other Transformations and Compositions** Other transformations like element-wise leaky-ReLU transformation (Oliva et al., 2018) and reverse transformation (Dinh et al., 2014) are readily applicable to transform the unobserved covariates  $x_u$  since they do not rely on the conditioning covariates. Other than these specific transformations described above, any transformations that follow the general formulation shown in Fig. 1(a) can be easily plugged into our model. We obtain flexible, highly non-linear transformations with the composition of multiple of these aforementioned transformations. (That is, we use the output of the preceding transformation as input to the next transformation.) The Jacobian of the resulting composed (stacked) transformation is accounted with the chain rule.

## 4.2. Arbitrary Conditional Likelihoods

The conditional likelihoods in latent space  $p(z_u | x_o, b)$  can be computed by either a base distribution, like a Gaussian,

or an autoregressive model as in TANs. For Gaussian based likelihoods, we can get mean and covariance parameters by applying another function over  $\phi(x_o; b)$  and  $b$ , which is essentially equivalent to another linear transformation conditioned on  $x_o$  and  $b$ . However, this approach is generally less flexible than using an autoregressive approach.

For autoregressive likelihoods, conditioning vectors can be used in the same way as the RNN coupling transformation. The difference is that the RNN outputs are now used to derive the parameters for some base distribution, for example, a Gaussian Mixture Model:

$$\begin{aligned} o^i, h^i &= \text{RNN}(\text{concat}(z_u^{i-1}, \phi(x_o; b), b), h^{i-1}), \\ p(z_u^i | z_u^{i-1}, \dots, z_u^1, x_o, b) &= \text{GMM}(z_u^i | \theta(o^i)), \end{aligned} \quad (10)$$

where  $\theta(o^i)$  is a shared fully connected network that maps to the parameters for the mixture model (i.e. each mixture component's location, scale, and mixing weight parameter). During sampling, we iteratively sample each point,  $z_u^{i-1}$ , before computing the parameters for  $z_u^i$ . Incorporating the autoregressive likelihood into Eq. (4) yields:

$$p(x_u | x_o, b) = \left| \det \frac{dq_{x_o, b}}{dx_u} \right| \prod_{i=1}^{|u|} p(z_u^i | z_u^{i-1}, \dots, z_u^1, x_o, b), \quad (11)$$

where  $|u|$  is the cardinality of the unobserved covariates.

## 4.3. Missing Data

During training, if we have access to complete training data, we will need to manually create binary masks  $b$  based on some predefined distribution  $p_b$ .  $p_b$  is typically chosen based on the application. For instance, Bernoulli random masks are commonly used for real-valued vectors. Given binary masks, training data  $x$  are divided into  $x_u$  and  $x_o$  and fed into the conditional model  $p(x_u | x_o, b)$ .

If training data already contains missing values, we can only train our model on the remaining covariates. As before, we manually split each data point into two parts,  $x_u$  and  $x_o$  based on a binary mask  $b$ . Note that dimensions in  $b$  corresponding to the missing values are always set to 0, i.e., they are never observed during training. In this setting, we will need another binary mask  $m$  indicating those dimensions that are not missing. Accordingly, we define observed dimensions as  $x_o = x[b]$  and unobserved dimensions as  $x_u = x[m \odot (1 - b)]$  and optimize  $p(x_u | x_o, m, b)$ .

## 4.4. Special Cases

We can easily see that arbitrary conditional model  $p(x_u | x_o, b)$  is a special case of  $p(x_u | x_o, m, b)$  if we set all dimensions of the binary mask  $m$  to one (no missing data). As a special case of ACFlow, the joint distribution  $p(x)$



can be modeled by the same framework when we set  $m$  to all ones (no missing data) and  $b$  to all zeros (no observed dimensions). Essentially, we are trying to model all the dimensions by conditioning on an empty set  $p(x | \emptyset)$ . Similarly, we can use ACFlow to model the arbitrary marginal distribution  $p(x_u)$  by setting  $m = 1 - b$ , that is, all the observed dimensions are treated as missing data. Note that  $x_u$  is an arbitrary subset of the covariates, thus, we are essentially modeling a mixture of all the marginals in just one single model.

#### 4.5. Imputation and Best Guess Objective

Given a trained ACFlow model, multiple imputations can be easily accomplished by drawing multiple samples from the learned conditional distribution. However, certain downstream tasks may require a single imputed “best guess”. Unfortunately, the analytical mean  $\mathbb{E}_{p(x_u|x_o,b)}[x_u]$  is not available for flow-based deep generative models. Furthermore, getting an accurate empirical estimate could be prohibitive in high dimensional space. In this work, we propose a robust solution that gives a single best guess in terms of the MSE metric (it can be easily extended to other metrics, e.g. an adversarial one).

Specifically, we obtain our best guess by inverting the conditional transformation over the mean of the latent distribution, i.e.,

$$q_{x_o,b}^{-1}(\bar{z}) = q_{x_o,b}^{-1}(\mathbb{E}_{p_Z(z|x_o,b)}[z]). \quad (12)$$

The mean  $\bar{z}$  is analytically available for Gaussian mixture base model. To ensure that this best guess is close to unobserved values, we optimize with an auxiliary MSE loss:

$$\mathcal{L} = -\log p(x_u | x_o, b) + \lambda \|q_{x_o,b}^{-1}(\bar{z}) - x_u\|^2, \quad (13)$$

where  $\lambda$  controls the relative importance of the auxiliary objective. Note that we only penalize one particular point from  $p(x_u | x_o, b)$  to be close to  $x_u$ . Hence, it does not affect the diversity of the conditional distribution.

## 5. Related Work

### 5.1. Arbitrary Conditional Models

Previous attempts to learn probability distributions conditioned on arbitrary subsets of known covariates include the Universal Marginalizer (Douglas et al., 2017), which is trained as a feed-forward network to approximate the marginal posterior distribution of each unobserved dimension conditioned on the observed ones. VAEAC (Ivanov et al., 2018), the *state-of-the-art* model so far for modeling arbitrary conditional likelihoods, utilizes a conditional variational autoencoder and extends it to deal with arbitrary conditioning. The decoder network outputs likelihoods that are over all possible dimensions, although, since they are conditionally independent given the latent code, it is possible

to use only the likelihoods corresponding to the unobserved dimensions. NeuralConditioner (NC) (Belghazi et al., 2019) is a GAN-based approach which leverages a discriminator to distinguish real data and generated samples.

Unlike VAEAC and NC, ACFlow is capable of producing an analytical (normalized) likelihood and avoids blurry samples and mode collapse problems ingrained in these approaches. Furthermore, in contrast to the Universal Marginalizer, ACFlow captures dependencies between unobserved covariates at training time via the change of variables formula.

Another type of model, Sum-Product Network (SPN) (Poon & Domingos, 2011), where the network structures are specially designed and contain only sum and product operations can evaluate both arbitrary conditional likelihoods and marginal likelihoods efficiently. SPN builds a DAG by stacking sum and product operations alternately so that the partition function can be efficiently computed. In contrast, ACFlow is more flexible since we do not pose constraints on the network structures. Please see Sec. 6.2.3 for empirical comparison between ACFlow and SPNs.

### 5.2. Missing Data Imputation

Classic methods for imputation include  $k$ -nearest neighbors (Troyanskaya et al., 2001), random forest (Stekhoven & Bühlmann, 2011) and auto-encoder (Gondara & Wang, 2018) approaches. Deep generative models have already been explored to handle missing data. MIWAE (Mattei & Frelsen, 2019) train a VAE model by a modified lower bound tailored for missing data and perform imputation by importance sampling. GAIN (Yoon et al., 2016) addresses data imputation with a GAN approach, where a generator produces imputations and a discriminator attempts to distinguish imputed covariates from observed covariates. MisGAN (Li et al., 2019a) is yet another GAN based method where they train a generator-discriminator pair for both data and masks.

Many missing data imputation methods assume that the data are missing completely at random (MCAR, missing independently of covariates’ values) or missing at random (MAR, possibly missing depending on observed covariates’ values) (Little & Rubin, 2019). Missing not at random (MNAR, missing depending on unobserved covariates’ values) is much harder to address, and requires some approximate inference technique such as variational approaches (Murray et al., 2018). In this work, we focus on the MCAR scenario.

## 6. Experiments

### 6.1. Synthetic Datasets

To validate the effectiveness of our model, we conduct experiments on synthetic 2-dimensional datasets, i.e.,  $x =$

$(x_1, x_2) \in \mathbb{R}^2$ . The joint distributions and imputed samples are plotted in Fig. 2. Here, the conditional distributions are highly multi-modal and vary significantly when conditioned on different observations. We train arbitrary conditional models on 100,000 samples from the joint distribution. The masks are generated by dropping out one dimension at random.

We compare our model against VAEAC (Ivanov et al., 2018), the current *state-of-the-art* model trained purely by likelihood. We closely follow the released code for VAEAC<sup>2</sup> to construct the proposal, prior, and generative networks. Specifically, we use fully connected layers and skip connections as is in their official implementation. We also use short-cut connections between the prior network and the generative network. We search over different combinations of the number of layers, the number of hidden units of fully connected layers, and the dimension of the latent code. Validation likelihoods are used to select the best model. The details about training procedure are provided in Appendix B. We see that ACFlow is capable of learning multi-modal distributions, while VAEAC tends to merge multiple modes into one single mode.

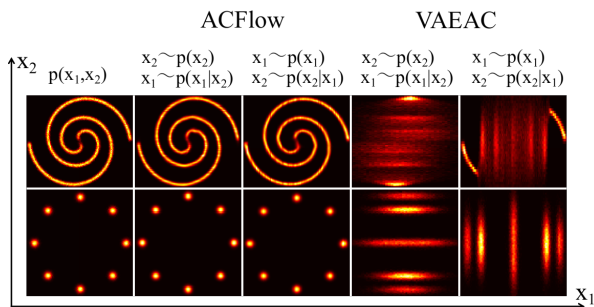

Figure 2. Synthetic datasets. Observed covariates are sampled from the marginal distributions, and the missing covariates are sampled from the learned conditional distributions.

## 6.2. Likelihood Evaluation

In this section, we evaluate the ability of ACFlow to model arbitrary conditional distributions in terms of the negative log-likelihoods (NLL). We compare to VAEAC (Ivanov et al., 2018) and an autoregressive counterpart (Salimans et al., 2017; Larochelle & Murray, 2011). In addition, as special cases, we compare arbitrary marginal likelihoods and the joint likelihoods against flow models.

### 6.2.1. IMAGE DATASETS

We evaluate our method on three common image datasets: MNIST, Omniglot and CelebA. We assume access to com-

<sup>2</sup>[https://github.com/tigvarts/vaeac/blob/master/imputation\\_networks.py](https://github.com/tigvarts/vaeac/blob/master/imputation_networks.py)

plete training data and train arbitrary conditional models  $p(x_u | x_o, b)$  with a varied distribution of binary masks  $p_b$ . Details about mask generation and image preprocessing are available in the Appendix C.1.

The architecture of ACFlow contains a sequence of arbitrary conditional transformations, which is akin to the RealNVP model (Dinh et al., 2016) except we replace all the coupling layers with our proposed arbitrary conditional alternative. The arbitrary conditional likelihood is implemented as a conditional PixelCNN conditioned on a vector embedding of the observed covariates. Implementation details of ACFlow and baselines are provided in Appendix C.2.

Table 1. NLL for modeling  $p(x_u | x_o)$ . Mean and std. dev. are computed by sampling 5 binary masks at random for each testing data. Lower is better.

	MNIST	Omniglot	CelebA
VAEAC	1034.86±6.05	1014.62±2.53	17638.83±15.21
PixelCNN	313.93±3.09	160.20±1.97	8806.02±34.95
ACFlow	<b>271.99±3.10</b>	<b>159.32±1.25</b>	<b>8387.01±45.86</b>

We first evaluate the ability to model arbitrary conditional distributions by comparing the negative log-likelihoods (NLL) in Table. 1. We generate 5 different masks for each test image and report the average scores and the standard deviation. We see that ACFlow outperforms VAEAC by a large margin and achieve *state-of-the-art* performance in terms of arbitrary conditional likelihoods. ACFlow also outperforms the PixelCNN model due to the transformations’ ability to capture dependencies across all covariates, while a PixelCNN model can only leverage preceding covariates to inference the current covariate.

As a special case, we evaluate the joint likelihood  $p(x)$  by setting the binary mask to all zeros during testing, i.e.  $p(x | \emptyset)$ , where we condition on an empty set to get likelihood for all covariates. Note that the model is trained using the conditional likelihood  $p(x_u | x_o)$  rather than the joint likelihood. In Table. 2 we compare

to the RealNVP model with similar architecture. We use Gaussian likelihood in this experiment for fair comparison. We see ACFlow achieves better or comparable likelihoods despite not directly trained to model the joint distribution. We believe that training ACFlow for multiple related tasks (the conditional likelihood tasks) with tied weights may act as a regularizer. Samples from the joint distributions are shown in Appendix C.3.

Table 2. Evaluate joint likelihood  $p(x)$  by setting bitmask  $b$  to all zeros. Results are presented as bits per dimension (bpd). Lower is better.

	ACFlow	RealNVP
MNIST	0.86	0.87
Omniglot	0.52	0.52
CIFAR10	3.50	3.49
CelebA	2.85	3.02

Besides conditioning on an empty set, we can apply a Gibbs

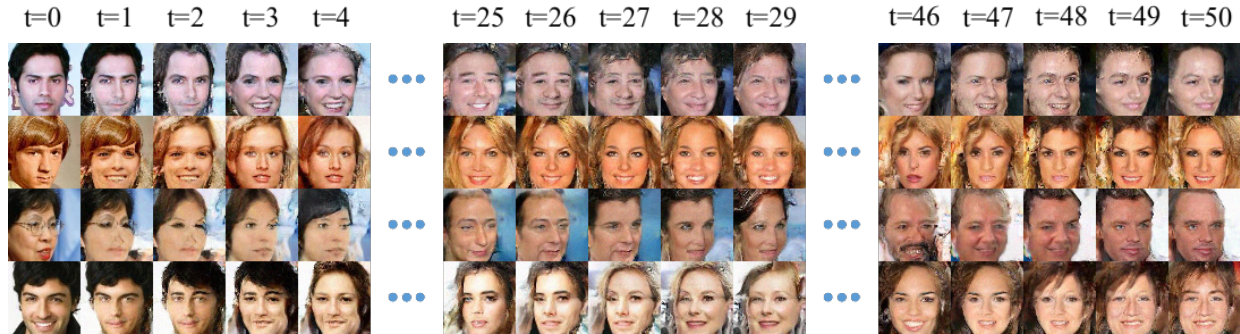

Figure 3. Gibbs sampling using a trained ACFlow. We iteratively sample the upper or lower half conditioned on the rest for 50 mixing steps. Note we reduce the bit depth to 5 in this experiment for better sample quality. More samples are shown in Appendix C.4.

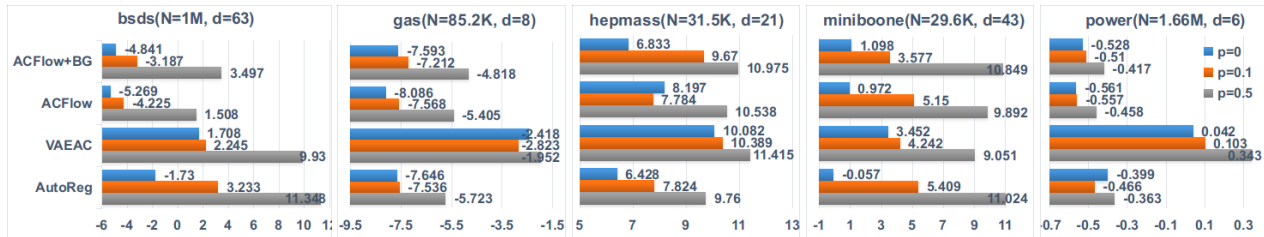

Figure 4. NLL for models trained on different level of missing rates (p). Lower is better. On top of each chart, we present the dataset name and its training set size (N) and feature dimensions (d). “BG” indicates the proposed best guess penalty.

sampling procedure to sample from the joint distribution. As shown in Fig. 3, we iteratively sample the upper or lower half conditioning on the remaining half for 50 mixing steps. We can see that the image changes smoothly and mixes well as the samples we get are very different from the starting point. This Gibbs sampling can be viewed as a way of exploring the local manifold from a specified starting point, an application that we will explore further in future work.

### 6.2.2. REAL-VALUED DATASETS

Next, we evaluate our model on real-valued tabular datasets. We use UCI repository datasets preprocessed as described in (Papamakarios et al., 2017). We construct models by composing several leaky-ReLU, conditional linear, and RNN coupling transformations, along with an autoregressive arbitrary conditional likelihood component. Please refer to Appendix. D.1 for further architectural details.

First, we consider non-missing training data. We construct masks,  $b$ , by dropping a random subset of the dimensions according to a Bernoulli distribution with  $p = 0.5$ . Afterwards, we also evaluate our model when the training data itself contains missing values that are never available during training. We consider training and testing with data features missing completely at random at a 10% and 50% rate.

Figure. 4 presents the arbitrary conditional NLL for models trained with different level of missing rates. We compare to

Table 3. Marginal log-likelihood evaluated on the first  $d$  dimensions. Note that ACFlow captures all the marginals in one single model, while different TANs are trained specifically for each case. Higher is better.

	d=3		d=5		d=10	
	ACFlow	TAN	ACFlow	TAN	ACFlow	TAN
bsds	5.06	5.11	9.26	9.43	19.60	20.44
gas	0.78	1.22	3.01	4.47	10.13	12.09
hepmass	-4.03	-4.00	-6.19	-5.92	-11.58	-10.87
miniboone	-2.76	-2.13	-5.31	-3.73	-10.36	-8.13
power	-0.57	-0.54	1.34	1.40	0.42	0.57

the current state-of-the-art, VAEAC, and an autoregressive model. One can see that our model gives better NLL on nearly all scenarios compared to VAEAC, which indicates our model is better at learning the true distribution. Our model also outperforms the autoregressive model for most cases.

In addition to the arbitrary conditional likelihoods, we can also train ACFlow to learn arbitrary marginal likelihoods. Similar to the arbitrary conditional case, a set of covariates have an exponential number of marginal distributions. We tested our model against TAN models trained explicitly on a particular subset of covariates (we use the first  $d$  dimensions for convenience); results are shown in Table. 3. Scatter plots from the first 3 dimensions of miniboone are shown in Fig. 5 and sam-



ples of other datasets are available in Appendix Fig. D.7.

Although the ACFlow model was trained for arbitrary marginals (and did not know which marginal tasks it would be evaluated on), it performed as well as flow models that were trained specifically for these marginals. Thus, we expect that a single ACFlow model would also generalize to any arbitrary marginal task, which would require one to train an exponential number of TAN flow models (one for each task). In essence, ACFlow is able to do approximate marginalization for flow methods, which was previously intractable.

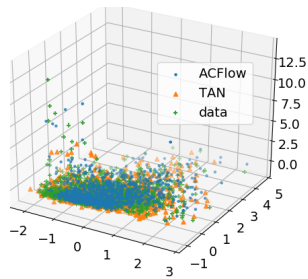

Figure 5. Marginal samples of minibooone from the first 3 dimensions.

### 6.2.3. COMPARISON WITH SPNS

SPNs (Poon & Domingos, 2011) model joint distributions with a specially designed architecture so that both arbitrary conditionals and marginals are tractable.

Table 4. Comparison with DCSPN on Olivetti Face dataset. MSE scores for DCSPN are from (Butz et al., 2019). Lower is better.

	left	bottom
DCSPN	455	503
ACFlow	415	434

for DCSPN are from their paper. Note that they train two separate models for different masks, while we handle both cases in one single ACFlow model and still obtain lower MSE scores.

Next, we conduct experiments on UCI dataset to compare with SPFlow (Molina et al., 2019), a python library for SPNs. We report results in terms of the conditional NLL, the NRMSE, and the marginal NLL in Tab. 5. The marginal likelihoods are evaluated for the first 3, 5 and 10 dimensions, respectively. In most of the cases, ACFlow outperforms SPFlow.

### 6.3. Imputation

Applying ACFlow for data imputation is straight-forward, since we can sample from the learned conditional distributions  $p(x_u | x_o)$ . In this section, we evaluate the performance of multiple and single imputations against other

First, we compare to the DCSPN (Butz et al., 2019) on Olivetti Face dataset. We evaluate the imputation performance by sampling from the conditional distributions  $p(x_u | x_o)$  using two different masks (denoted as ‘left’ and ‘bottom’). Results are shown in Tab. 4. The MSE scores

Table 5. Comparison to SPFlow on UCI datasets. Lower is better.

		bsds	gas	hepmass	miniboone	power
$p(x_u   x_o)$	SPFlow	24.15	-4.30	12.78	18.34	1.03
	ACFlow	-5.27	-8.09	8.20	0.97	-0.56
NRMSE	SPFlow	1.01	0.37	1.02	0.76	0.95
	ACFlow	0.60	0.57	0.91	0.48	0.88
$p(x[:3])$	SPFlow	2.87	-0.68	4.01	2.21	0.63
	ACFlow	-5.06	-0.78	4.03	2.76	0.57
$p(x[:5])$	SPFlow	4.42	-1.88	6.58	4.31	-1.01
	ACFlow	-9.26	-3.01	6.19	5.31	-1.34
$p(x[:10])$	SPFlow	8.15	-4.81	13.38	9.85	0.12
	ACFlow	-19.60	-10.13	11.58	10.36	-0.42

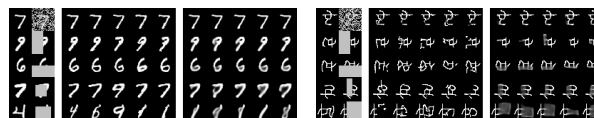

(a) MNIST inpaintings

(b) Omniglot inpaintings

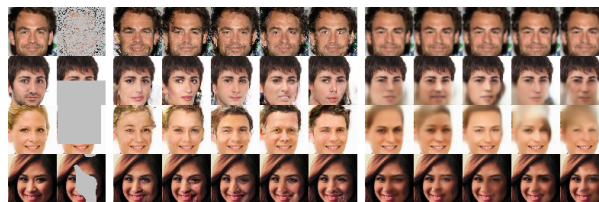

(c) CelebA inpaintings

Figure 6. Image Inpaintings. Left: groundtruth and inputs. Middle: samples from ACFlow. Right: samples from VAEAC.

likelihood based generative models, such as VAEAC and autoregressive models. We also compare to classic imputation methods, such as MICE (Buuren & Groothuis-Oudshoorn, 2010) and MissForest (Stekhoven & Bühlmann, 2012).

#### 6.3.1. IMAGE INPAINTING

Figure. 6 shows multiple imputation results from VAEAC and ACFlow (We use a Gaussian base likelihood for this experiment, since sampling from an autoregressive model is time consuming.). More samples are available in Appendix C.5. We notice ACFlow can generate coherent and diverse inpaintings for all three datasets and different masks. Compared to VAEAC, our model generates sharp samples and restores more detail. Even when the missing rate is high, ACFlow can still generate decent inpaintings.

To quantitatively evaluate the inpainting performance, we report the peak signal-to-noise ratio (PSNR) and the precision and recall scores (PRD) (Sajjadi et al., 2018) in Table. 6. We note that PSNR is a metric that may prefer blurry images over sample diversity (Hore & Ziou, 2010), hence we evaluate the trade-off between sample quality and diversity via the precision and recall scores (PRD) (Sajjadi et al., 2018). Since we cannot sample from the groundtruth conditional



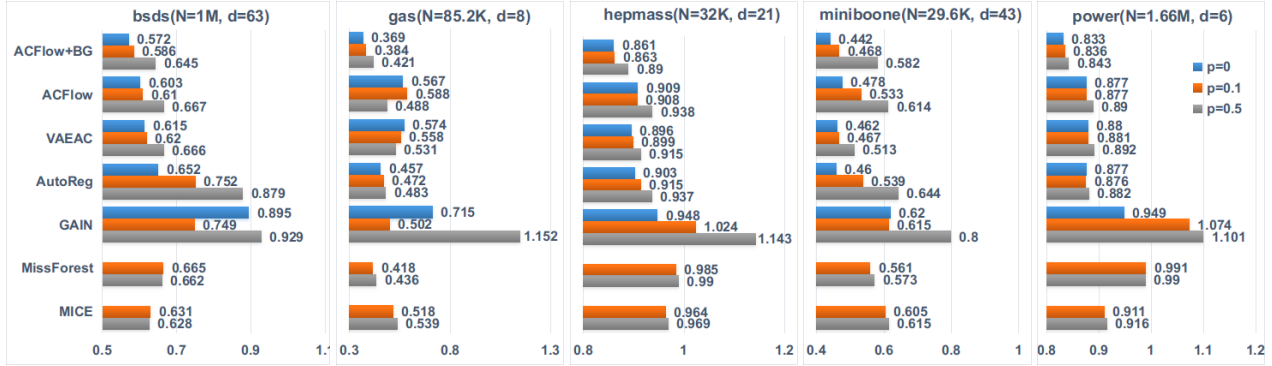

Figure 7. NRMSE results for real-valued feature imputation on UCI datasets. Lower is better. We test MICE and MissForest only when the missing rate ( $p$ ) is not zero.

Table 6. Inpainting results. Mean and std. dev. are computed by sampling 5 binary masks for each testing data. Higher is better.

		MNIST	Omniglot	CelebA
VAEAC	PSNR	19.613±0.042	17.693±0.023	23.656±0.027
	PRD	(0.975, 0.877)	(0.926, 0.525)	(0.966, 0.967)
ACFlow	PSNR	17.349±0.018	15.572±0.031	22.393±0.040
	PRD	<b>(0.984, 0.945)</b>	<b>(0.971, 0.962)</b>	<b>(0.988, 0.970)</b>
ACFlow+BG	PSNR	<b>20.828±0.031</b>	<b>18.838±0.009</b>	<b>25.723±0.020</b>
	PRD	(0.983, <b>0.947</b> )	(0.970, <b>0.967</b> )	(0.987, 0.964)

distribution, we compute the PRD score between the imputed joint distribution  $p(x_o)p(x_u | x_o)$  and the true joint distribution  $p(x)$  via sampling 10,000 points. The PRD scores for two distributions measure how much of one distribution can be generated by another. Higher recall means a greater portion of samples from the true distribution  $p(x)$  are covered by  $p(x_o)p(x_u | x_o)$ ; and similarly, higher precision means a greater portion of samples from  $p(x_o)p(x_u | x_o)$  are covered by  $p(x)$ . We report the  $(F_s, F_p)$  pairs in Table 6 to represent recall and precision, respectively.

From the quantitative results, we see that our model gives higher PSNR and PRD scores compared to VAEAC, demonstrating that our model better learns the true distribution. Training with the auxiliary “best guess” penalty (denoted as “ACFlow+BG”) can further improve the PSNR scores significantly, but hardly impacts the PRD scores, which verifies that the proposed penalty does not affect the diversity of the model.

### 6.3.2. FEATURE IMPUTATION

In Figure 7, we compare feature imputation performance using NRMSE (i.e. root mean squared error normalized by the standard deviation of each feature and then averaged across all features). For models that can perform multiple imputation, 10 imputations are drawn for each test point to

compute the average NRMSE scores. For our model trained with the auxiliary objective (ACFlow+BG), we use the single “best guess” to compute the NRMSE. In order to not bias towards any specific missing pattern, we report the mean and standard deviations over 5 randomly generated binary masks (std. dev. are reported in Appendix Table. D.1).

Quantitatively, ACFlow is comparable to the previous state-of-the-art when trained purely by maximizing the likelihood. However, training with the auxiliary objective improves the NRMSE scores significantly and gives state-of-the-art results on all datasets considered. As expected, higher missing rate makes it harder to learn the dependencies; however, our model performs best even when the missing rate is relatively high.

## 7. Conclusion

In this work, we demonstrated that we can model the arbitrary conditional distributions  $p(x_u | x_o)$  using a single model by leveraging conditional flow transformations and conditional autoregressive likelihoods. As special cases, ACFlow can also achieve good performance for modeling the joint distributions and arbitrary marginal distributions. In regard to applications, ACFlow is applied to imputation tasks and it empirically outperforms several strong baselines. We also considered performing both single and multiple imputations in a unified platform to provide a “best guess” single imputation when the mean is not analytically available. The samples generated from our model show that we improve in both diversity and quality of imputations in many datasets. Our model typically recovers more details than the previous state-of-the-art methods. In future work, we will apply ACFlow to reason about causal relationships and learn underlying graphical structures. Our code is available at <https://github.com/lupalab/ACFlow>.

## Acknowledgements

This work was supported in part by the NIH 1R01AA026879-01A1 grant.

## References

- Behrmann, J., Duvenaud, D., and Jacobsen, J.-H. Invertible residual networks. *arXiv preprint arXiv:1811.00995*, 2018.
- Belghazi, M. I., Oquab, M., LeCun, Y., and Lopez-Paz, D. Learning about an exponential amount of conditional distributions. *arXiv preprint arXiv:1902.08401*, 2019.
- Butz, C. J., Oliveira, J. S., dos Santos, A. E., and Teixeira, A. L. Deep convolutional sum-product networks. In *Proceedings of the AAAI Conference on Artificial Intelligence*, volume 33, pp. 3248–3255, 2019.
- Buuren, S. v. and Groothuis-Oudshoorn, K. Mice: Multivariate imputation by chained equations in r. In *Journal of statistical software*, pp. 1–68, 2010.
- Chen, X., Duan, Y., Houthoofd, R., Schulman, J., Sutskever, I., and Abbeel, P. Infogan: Interpretable representation learning by information maximizing generative adversarial nets. In *Advances in neural information processing systems*, pp. 2172–2180, 2016.
- Dinh, L., Krueger, D., and Bengio, Y. Nice: Non-linear independent components estimation. *arXiv preprint arXiv:1410.8516*, 2014.
- Dinh, L., Sohl-Dickstein, J., and Bengio, S. Density estimation using real nvp. *arXiv preprint arXiv:1605.08803*, 2016.
- Douglas, L., Zarov, I., Gourgoulas, K., Lucas, C., Hart, C., Baker, A., Sahani, M., Perov, Y., and Johri, S. A universal marginalizer for amortized inference in generative models. *arXiv preprint arXiv:1711.00695*, 2017.
- Gondara, L. and Wang, K. Mida: Multiple imputation using denoising autoencoders. In *Pacific-Asia Conference on Knowledge Discovery and Data Mining*, pp. 260–272. Springer, 2018.
- He, K., Zhang, X., Ren, S., and Sun, J. Deep residual learning for image recognition. In *Proceedings of the IEEE conference on computer vision and pattern recognition*, pp. 770–778, 2016.
- Hore, A. and Ziou, D. Image quality metrics: Psnr vs. ssim. In *2010 20th International Conference on Pattern Recognition*, pp. 2366–2369, Aug 2010. doi: 10.1109/ICPR.2010.579.
- Houthoofd, R., Chen, X., Duan, Y., Schulman, J., De Turck, F., and Abbeel, P. Vime: Variational information maximizing exploration. In *Advances in Neural Information Processing Systems*, pp. 1109–1117, 2016.
- Ivanov, O., Figurnov, M., and Vetrov, D. Variational autoencoder with arbitrary conditioning. *arXiv preprint arXiv:1806.02382*, 2018.
- Kingma, D. P. and Dhariwal, P. Glow: Generative flow with invertible 1x1 convolutions. In *Advances in Neural Information Processing Systems*, pp. 10215–10224, 2018.
- Larochelle, H. and Murray, I. The neural autoregressive distribution estimator. In *Proceedings of the Fourteenth International Conference on Artificial Intelligence and Statistics*, pp. 29–37, 2011.
- Ledig, C., Theis, L., Huszár, F., Caballero, J., Cunningham, A., Acosta, A., Aitken, A., Tejani, A., Totz, J., Wang, Z., et al. Photo-realistic single image super-resolution using a generative adversarial network. In *Proceedings of the IEEE conference on computer vision and pattern recognition*, pp. 4681–4690, 2017.
- Li, S. C.-X., Jiang, B., and Marlin, B. Misgan: Learning from incomplete data with generative adversarial networks. *arXiv preprint arXiv:1902.09599*, 2019a.
- Li, Y., Liu, S., Yang, J., and Yang, M.-H. Generative face completion. In *Proceedings of the IEEE Conference on Computer Vision and Pattern Recognition*, pp. 3911–3919, 2017.
- Li, Y., Gao, T., and Oliva, J. A forest from the trees: Generation through neighborhoods. *arXiv preprint arXiv:1902.01435*, 2019b.
- Little, R. J. and Rubin, D. B. *Statistical analysis with missing data*, volume 793. John Wiley & Sons, 2019.
- Mattei, P.-A. and Frellsen, J. Miwae: Deep generative modelling and imputation of incomplete data sets. In *International Conference on Machine Learning*, pp. 4413–4423, 2019.
- Molina, A., Vergari, A., Stelzner, K., Peharz, R., Subramani, P., Di Mauro, N., Poupart, P., and Kersting, K. Spflow: An easy and extensible library for deep probabilistic learning using sum-product networks. *arXiv preprint arXiv:1901.03704*, 2019.
- Murray, J. S. et al. Multiple imputation: A review of practical and theoretical findings. *Statistical Science*, 33(2): 142–159, 2018.
- Oliva, J. B., Dubey, A., Zaheer, M., Póczos, B., Salakhutdinov, R., Xing, E. P., and Schneider, J. Transformation autoregressive networks. *arXiv preprint arXiv:1801.09819*, 2018.

- Papamakarios, G., Pavlakou, T., and Murray, I. Masked autoregressive flow for density estimation. In *Advances in Neural Information Processing Systems*, pp. 2338–2347, 2017.
- Pathak, D., Krahenbuhl, P., Donahue, J., Darrell, T., and Efros, A. A. Context encoders: Feature learning by inpainting. In *Proceedings of the IEEE conference on computer vision and pattern recognition*, pp. 2536–2544, 2016.
- Poon, H. and Domingos, P. Sum-product networks: A new deep architecture. In *2011 IEEE International Conference on Computer Vision Workshops (ICCV Workshops)*, pp. 689–690. IEEE, 2011.
- Sajjadi, M. S., Bachem, O., Lucic, M., Bousquet, O., and Gelly, S. Assessing generative models via precision and recall. In *Advances in Neural Information Processing Systems*, pp. 5228–5237, 2018.
- Salimans, T., Karpathy, A., Chen, X., and Kingma, D. P. Pixelcnn++: Improving the pixelcnn with discretized logistic mixture likelihood and other modifications. *arXiv preprint arXiv:1701.05517*, 2017.
- Stekhoven, D. J. and Bühlmann, P. Missforest—non-parametric missing value imputation for mixed-type data. *Bioinformatics*, 28(1):112–118, 2011.
- Stekhoven, D. J. and Bühlmann, P. Missforest — non-parametric missing value imputation for mixed-type data. In *Bioinformatics, Volume 28, Issue 1*, pp. 112–118, 2012.
- Troyanskaya, O., Cantor, M., Sherlock, G., Brown, P., Hastie, T., Tibshirani, R., Botstein, D., and Altman, R. B. Missing value estimation methods for dna microarrays. *Bioinformatics*, 17(6):520–525, 2001.
- Yoon, J., Jordon, J., and Schaar, M. v. d. Gain: Missing data imputation using generative adversarial nets. *arXiv preprint arXiv:1605.08803*, 2016.